



US 20060257286A1

(19) **United States**

(12) **Patent Application Publication**
Adams

(10) **Pub. No.: US 2006/0257286 A1**

(43) **Pub. Date: Nov. 16, 2006**

(54) **SELF-SENSING ARRAY OF
MICROCANTILEVERS FOR CHEMICAL
DETECTION**

Publication Classification

(76) Inventor: **Jesse D. Adams, Reno, NV (US)**

(51) **Int. Cl.**
G01N 27/00 (2006.01)
B32B 27/04 (2006.01)
B32B 27/12 (2006.01)
B32B 5/02 (2006.01)

(52) **U.S. Cl.** **422/82.01**

Correspondence Address:
KLARQUIST SPARKMAN, LLP
121 SW SALMON STREET
SUITE 1600
PORTLAND, OR 97204 (US)

(57) **ABSTRACT**

The invention provides a chemical detection system for detecting at least one target chemical species, including a self-sensed cantilevered probe array having a plurality of self-sensed cantilevered probes, at least one chemical-sensitive coating material applied to at least one cantilevered probe in the cantilevered probe array, and an interface circuit that is coupled to the cantilevered probe array. At least one cantilevered probe in the cantilevered probe array exhibits a shifted cantilevered probe response when the cantilevered probe array is exposed to the target chemical species and the interface circuit actuates the cantilevered probe. A handheld chemical detection system and a method of operation are also disclosed.

(21) Appl. No.: **10/967,748**

(22) Filed: **Oct. 15, 2004**

Related U.S. Application Data

(60) Provisional application No. 60/512,504, filed on Oct. 17, 2003.

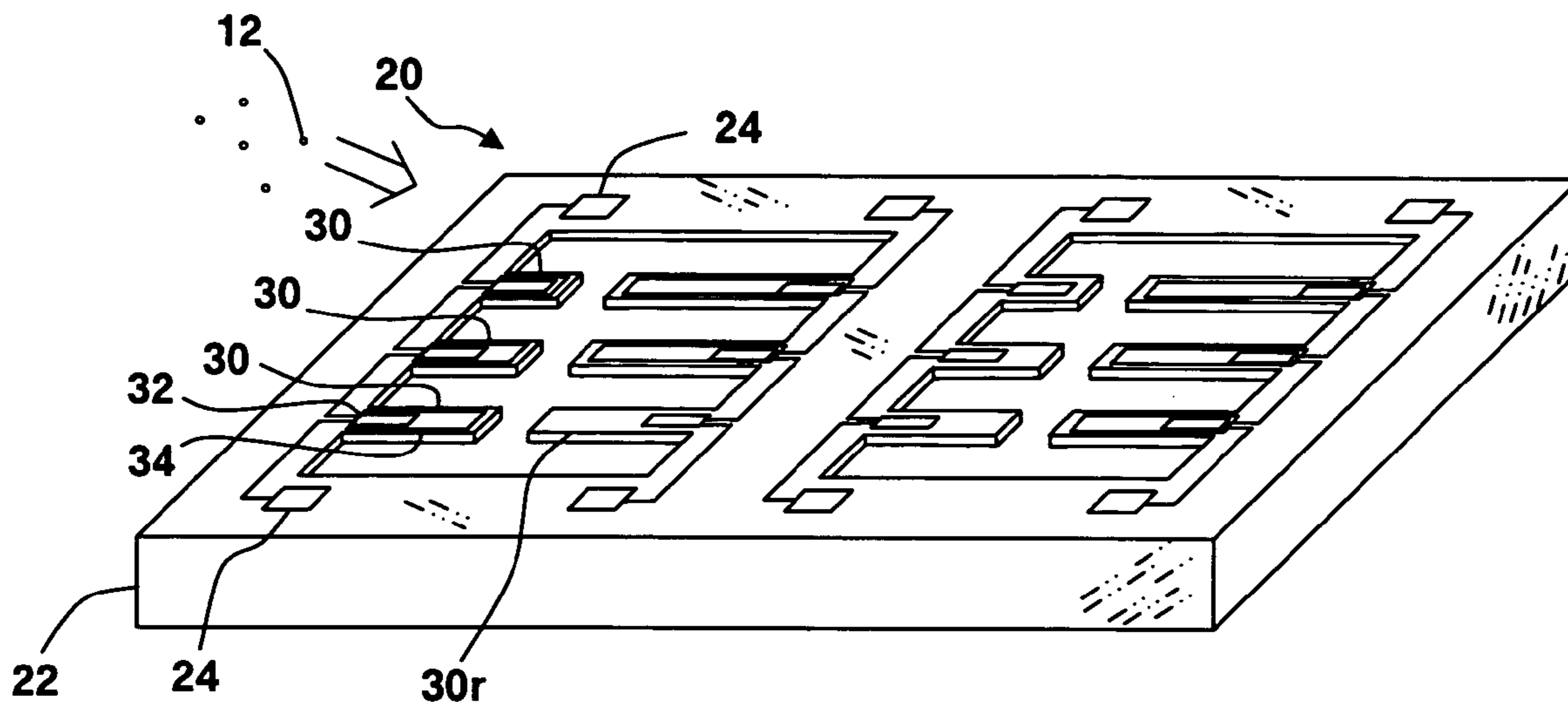

FIG. 1

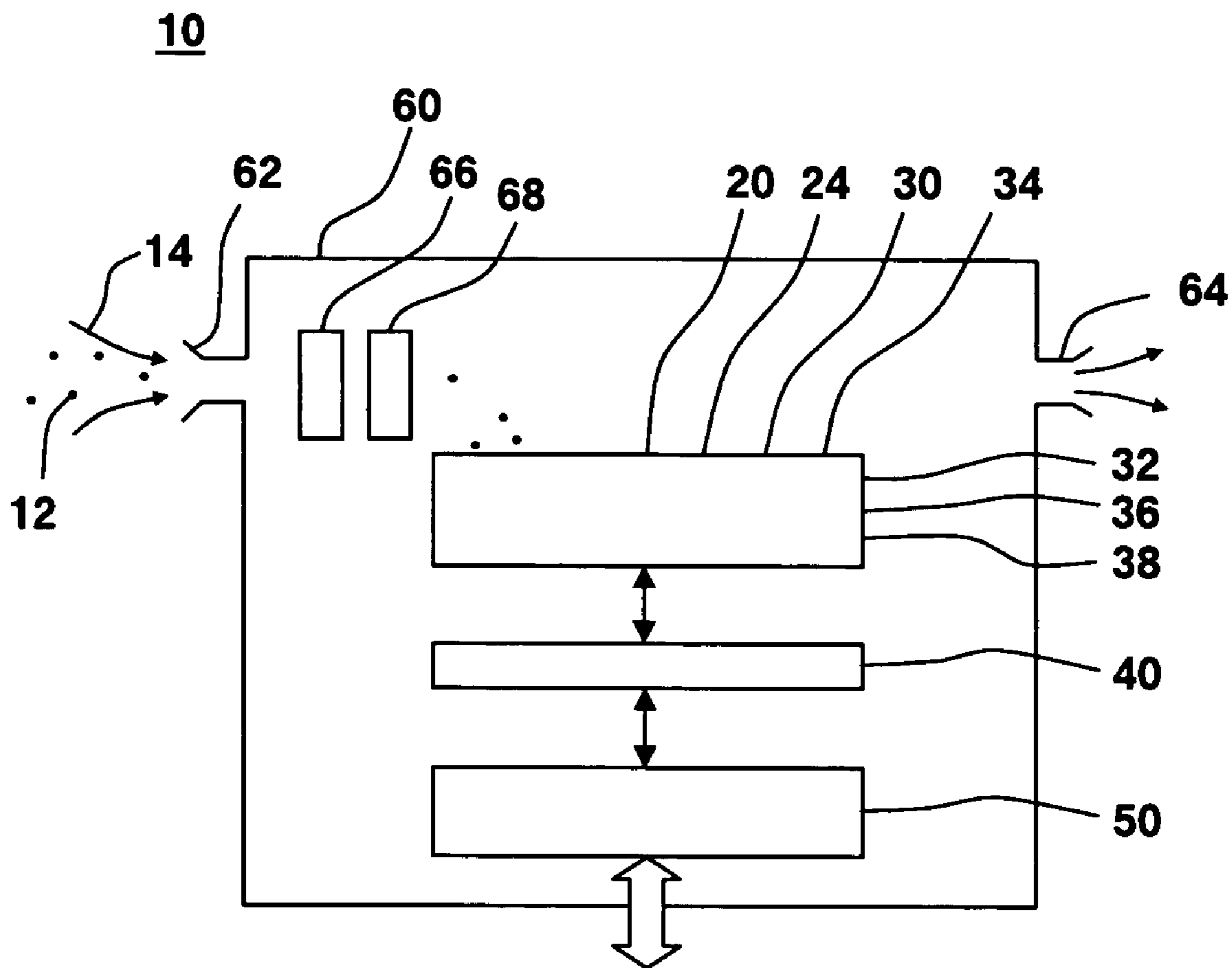

FIG. 2

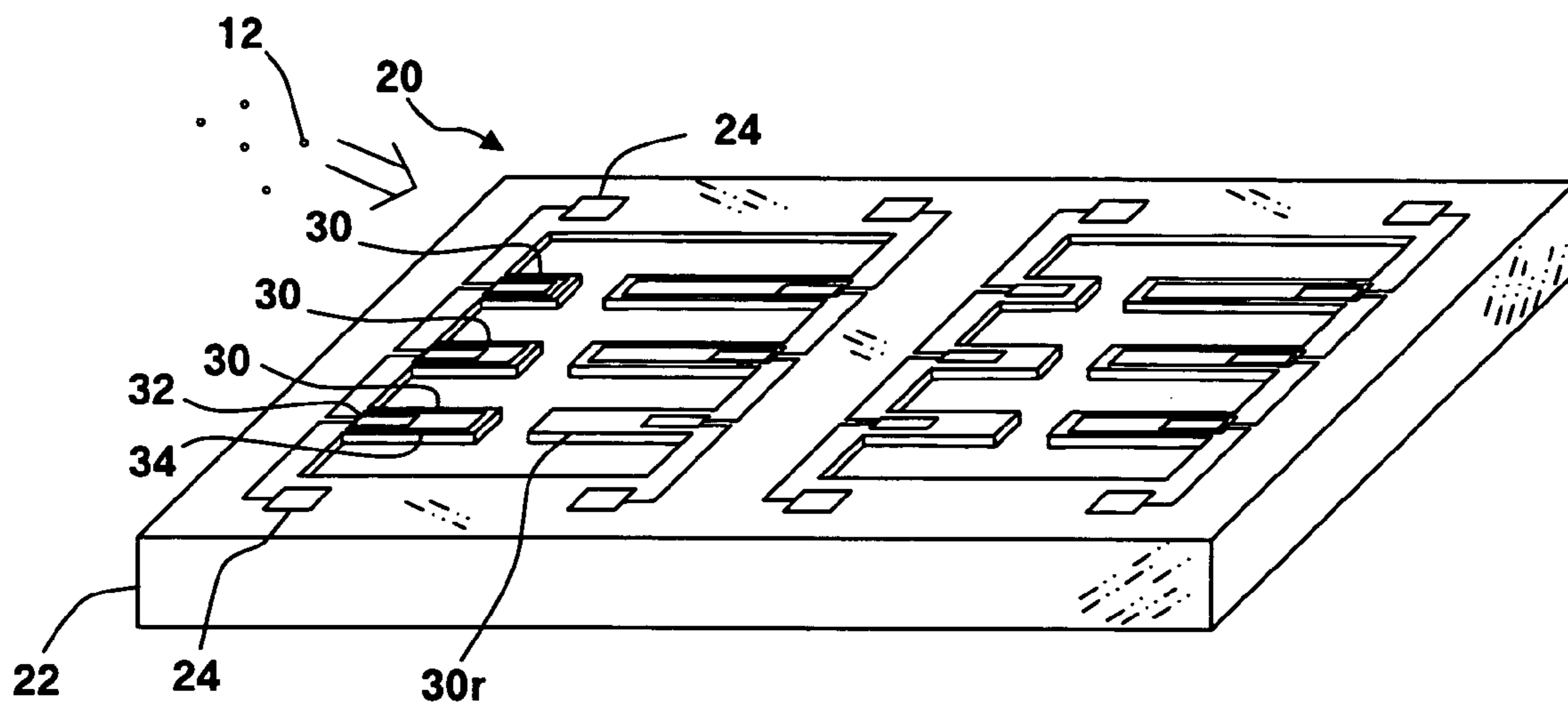

FIG. 3

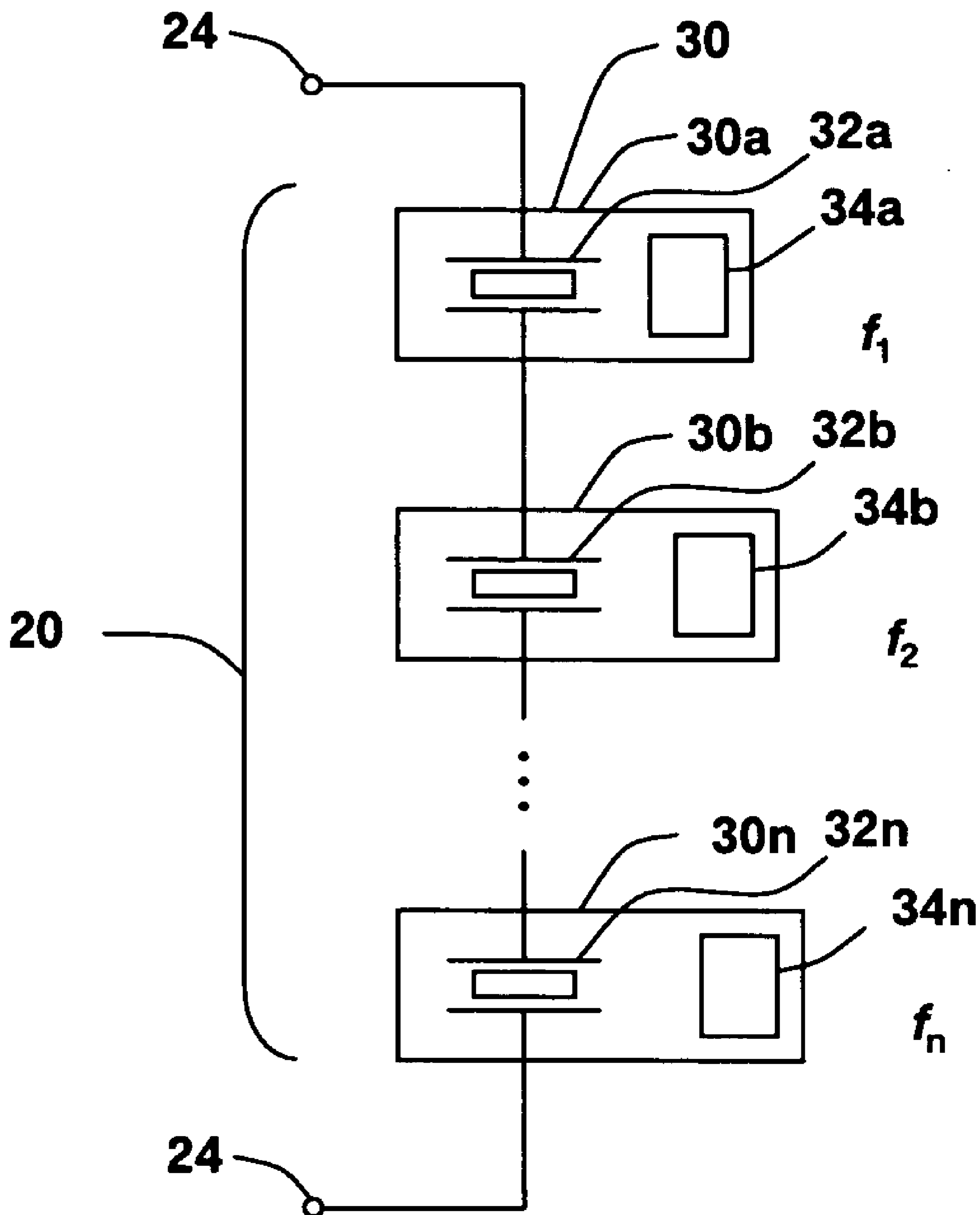

FIG. 4

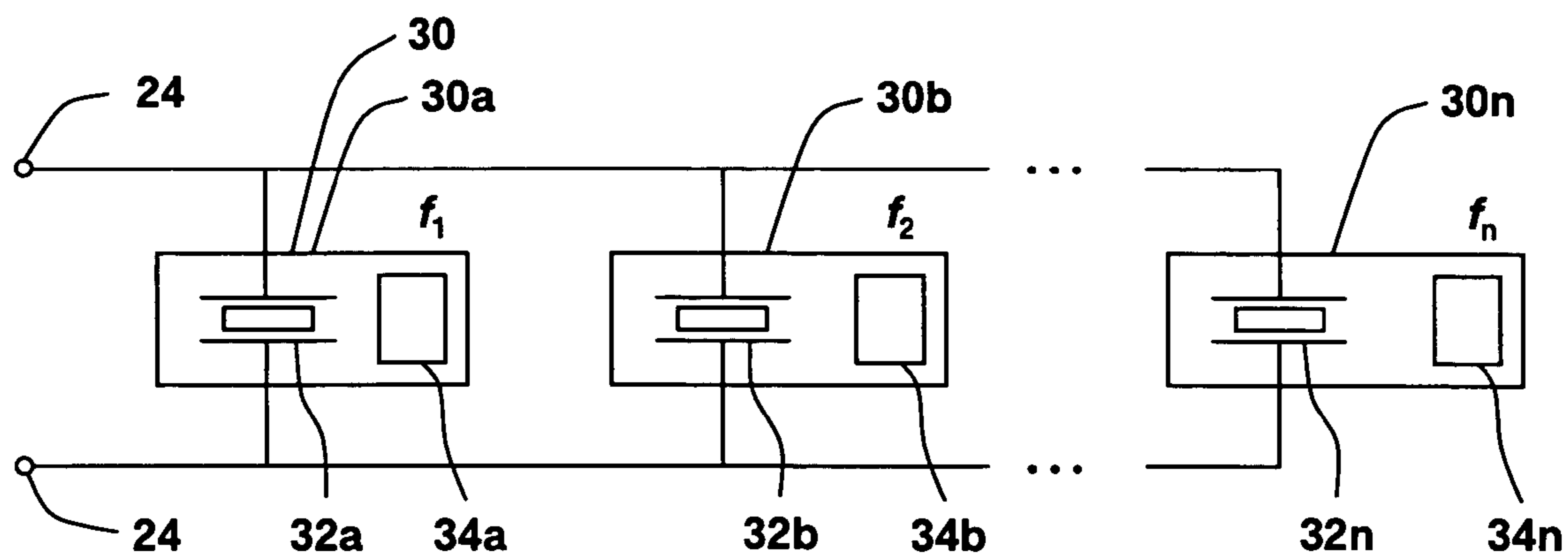

FIG. 5

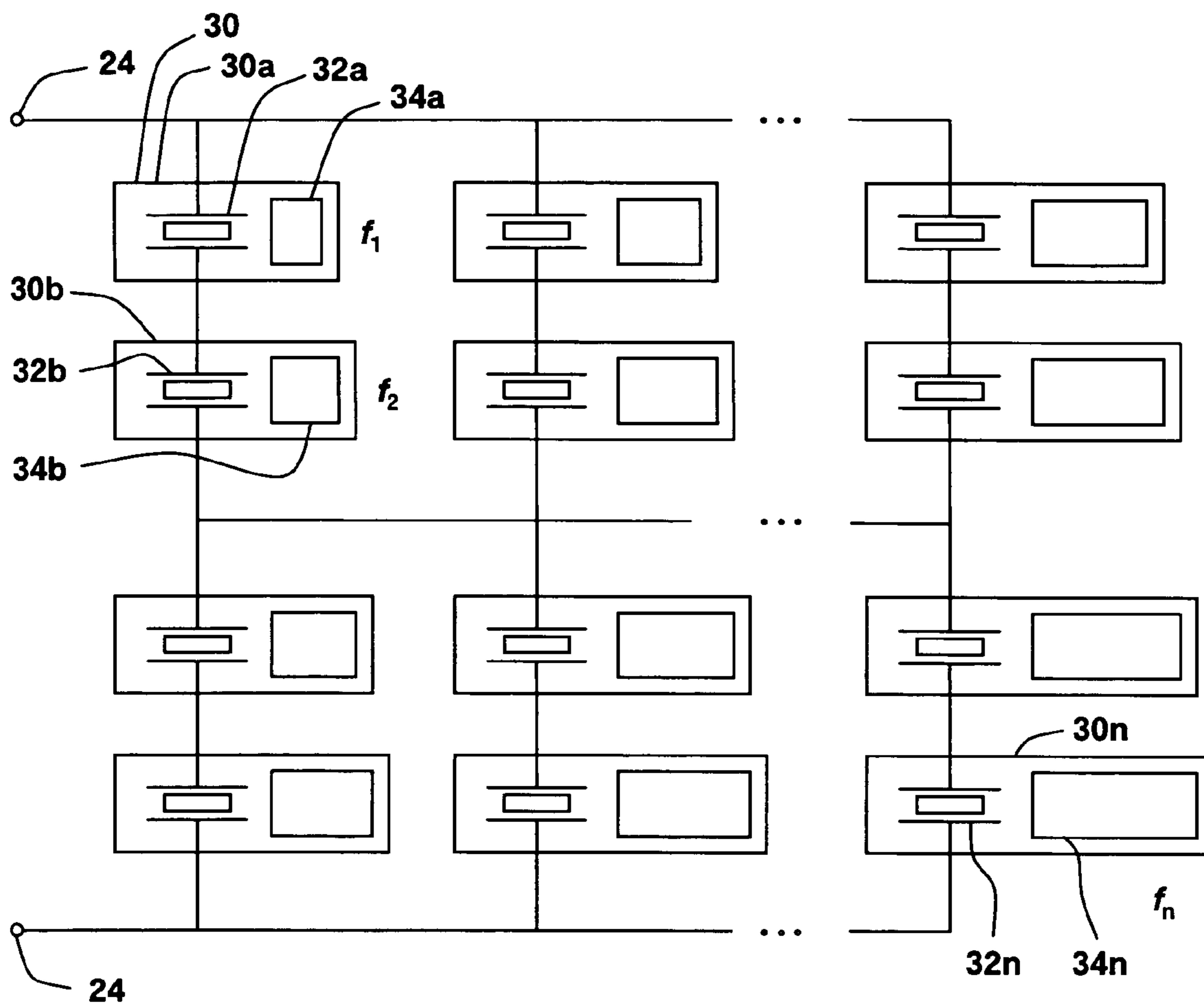

FIG. 6a

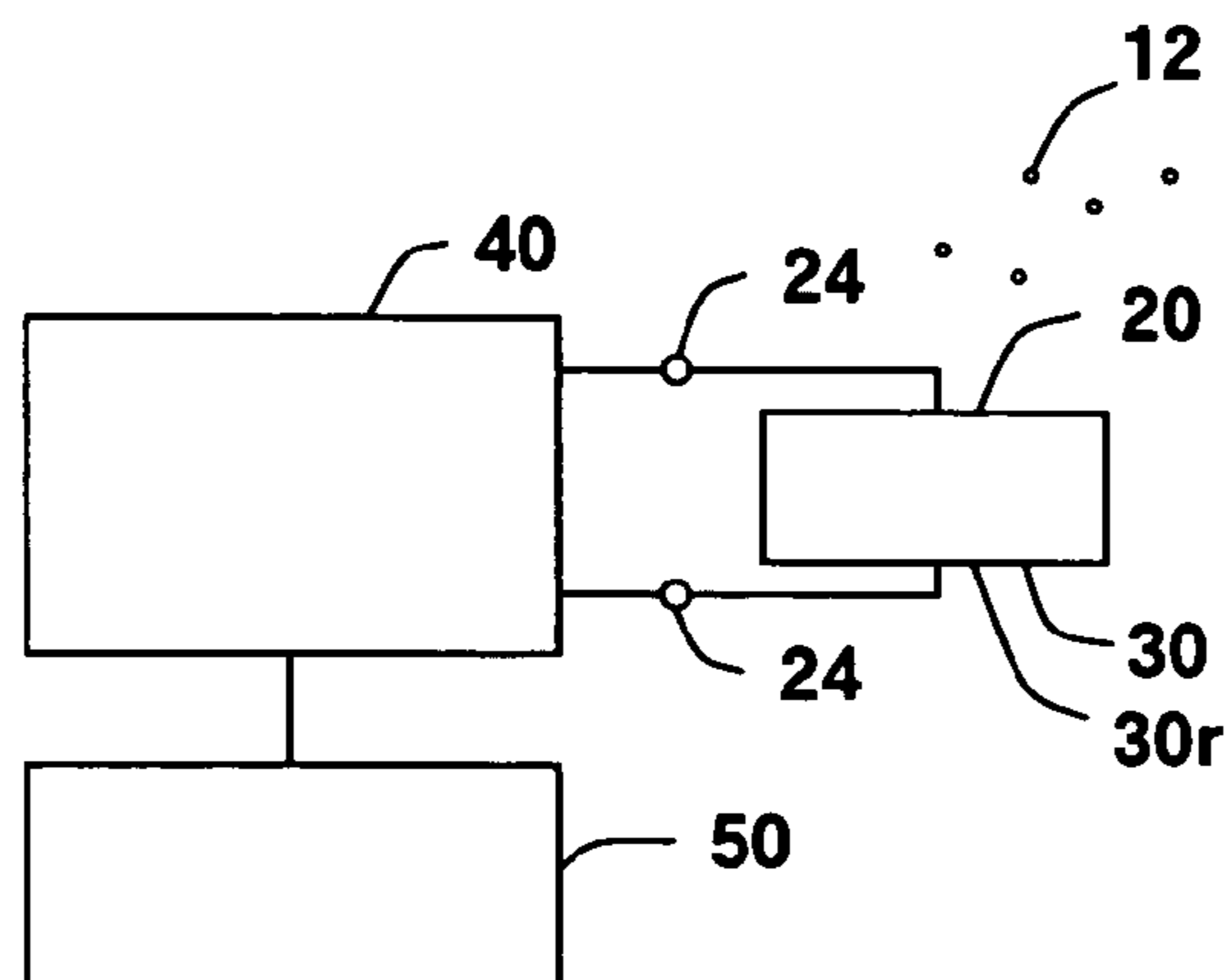

FIG. 6b

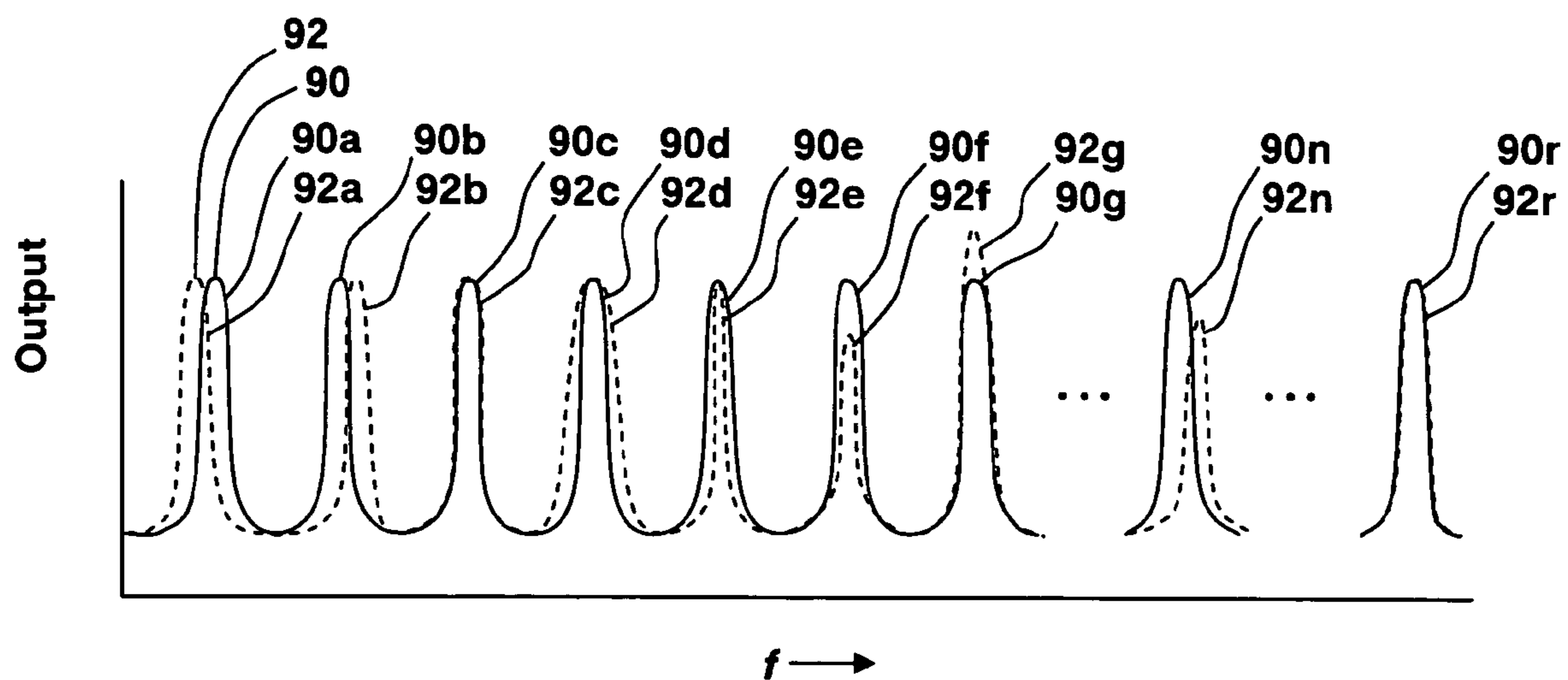

FIG. 7

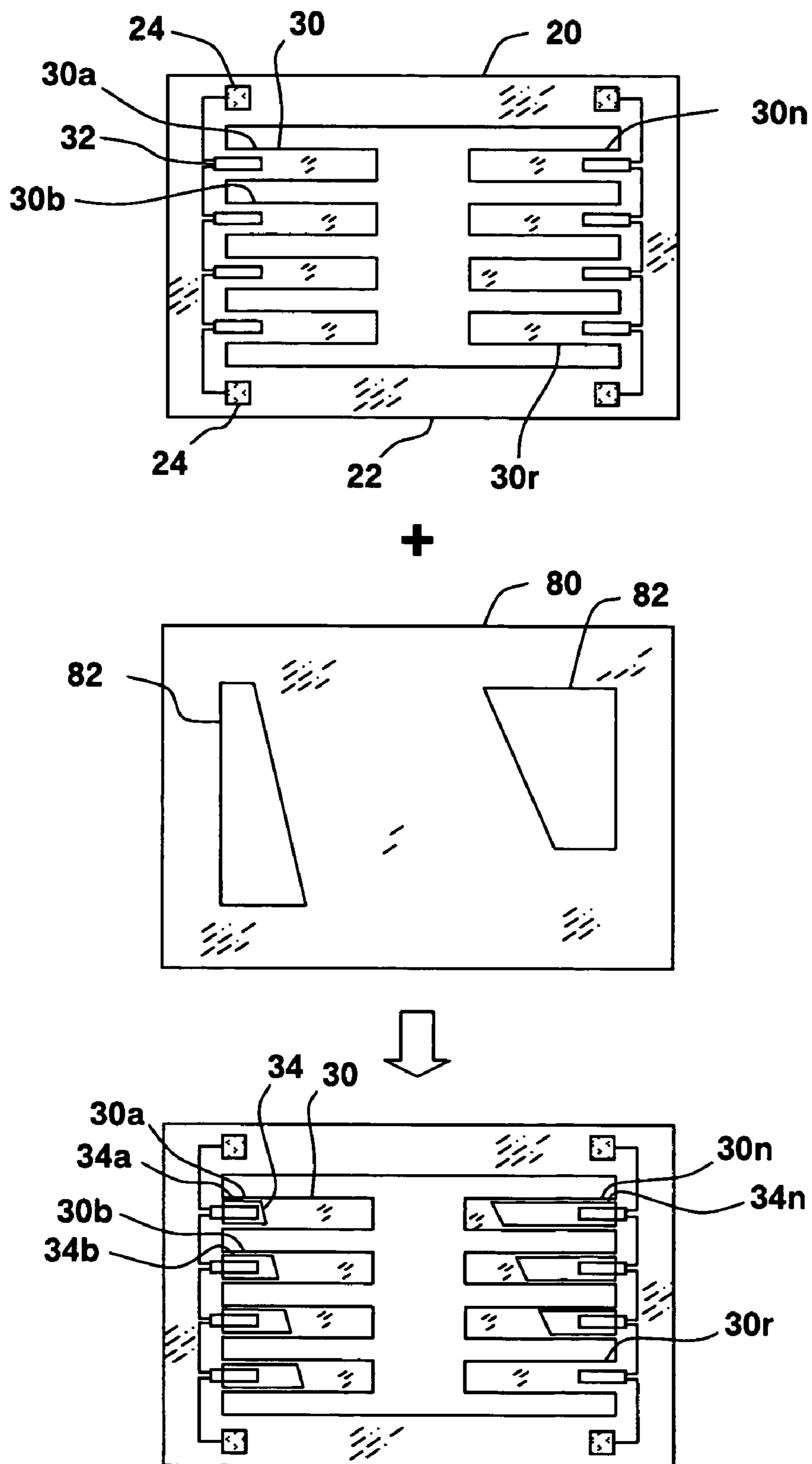

FIG. 8

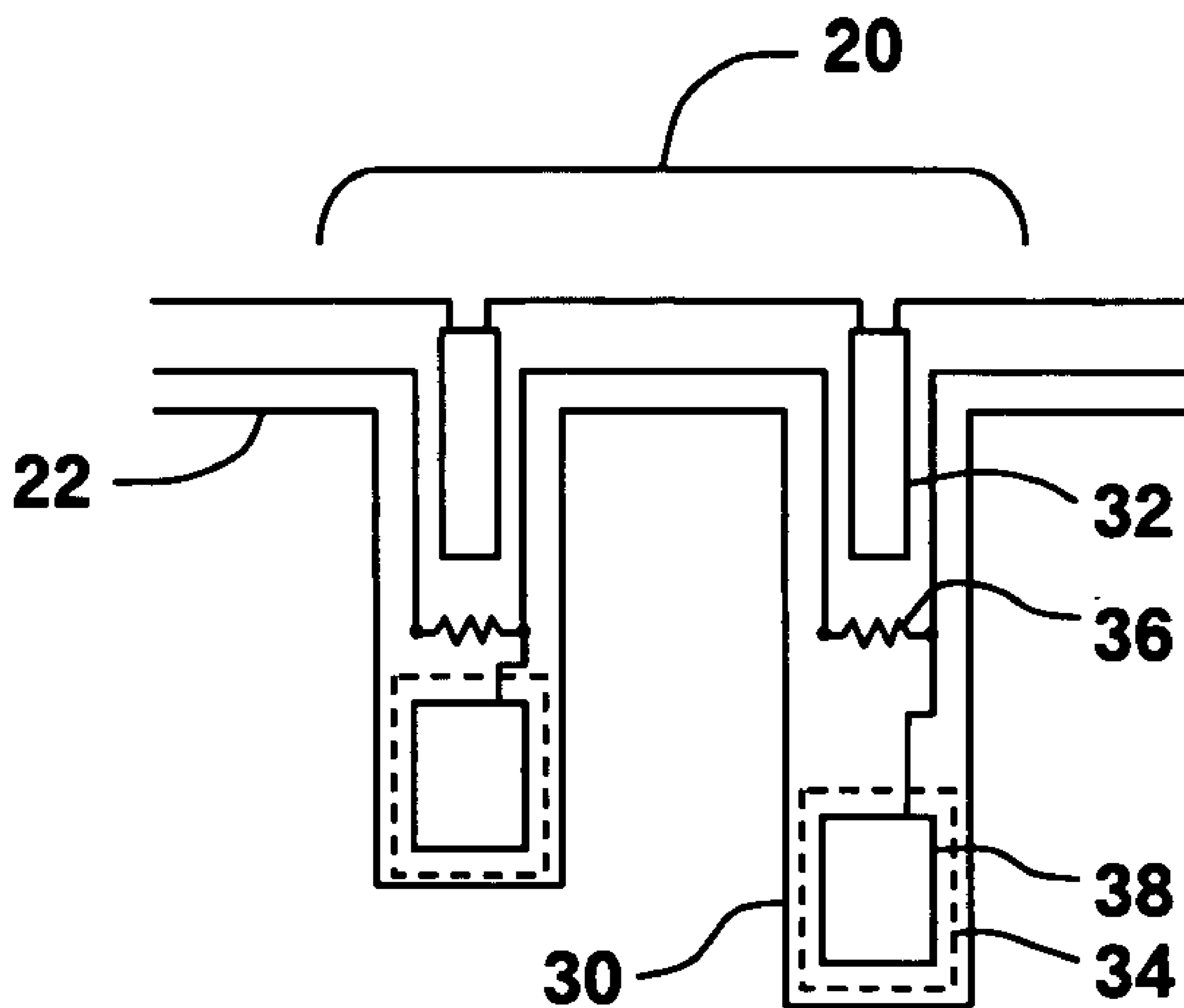

FIG. 9

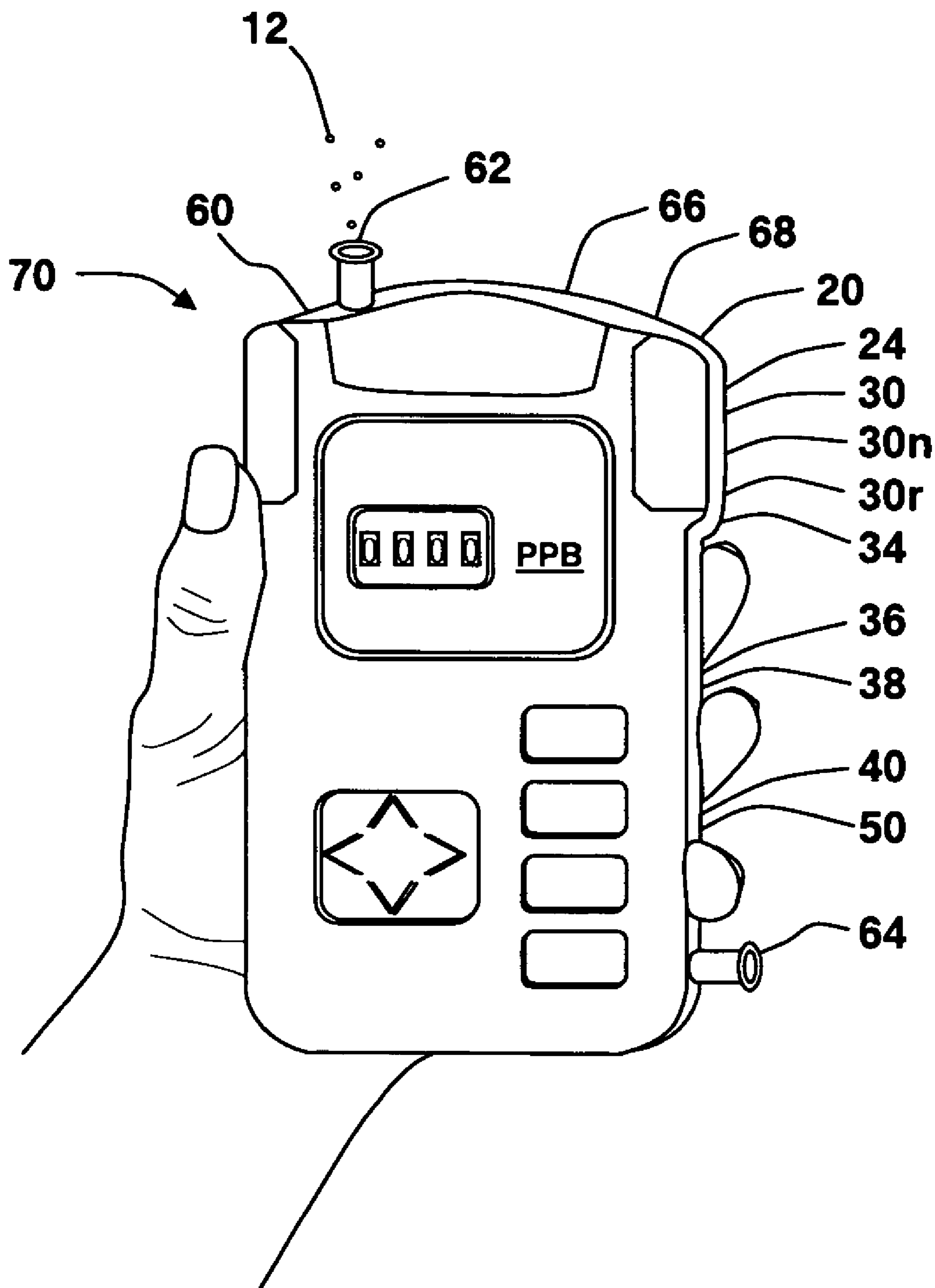

FIG. 10

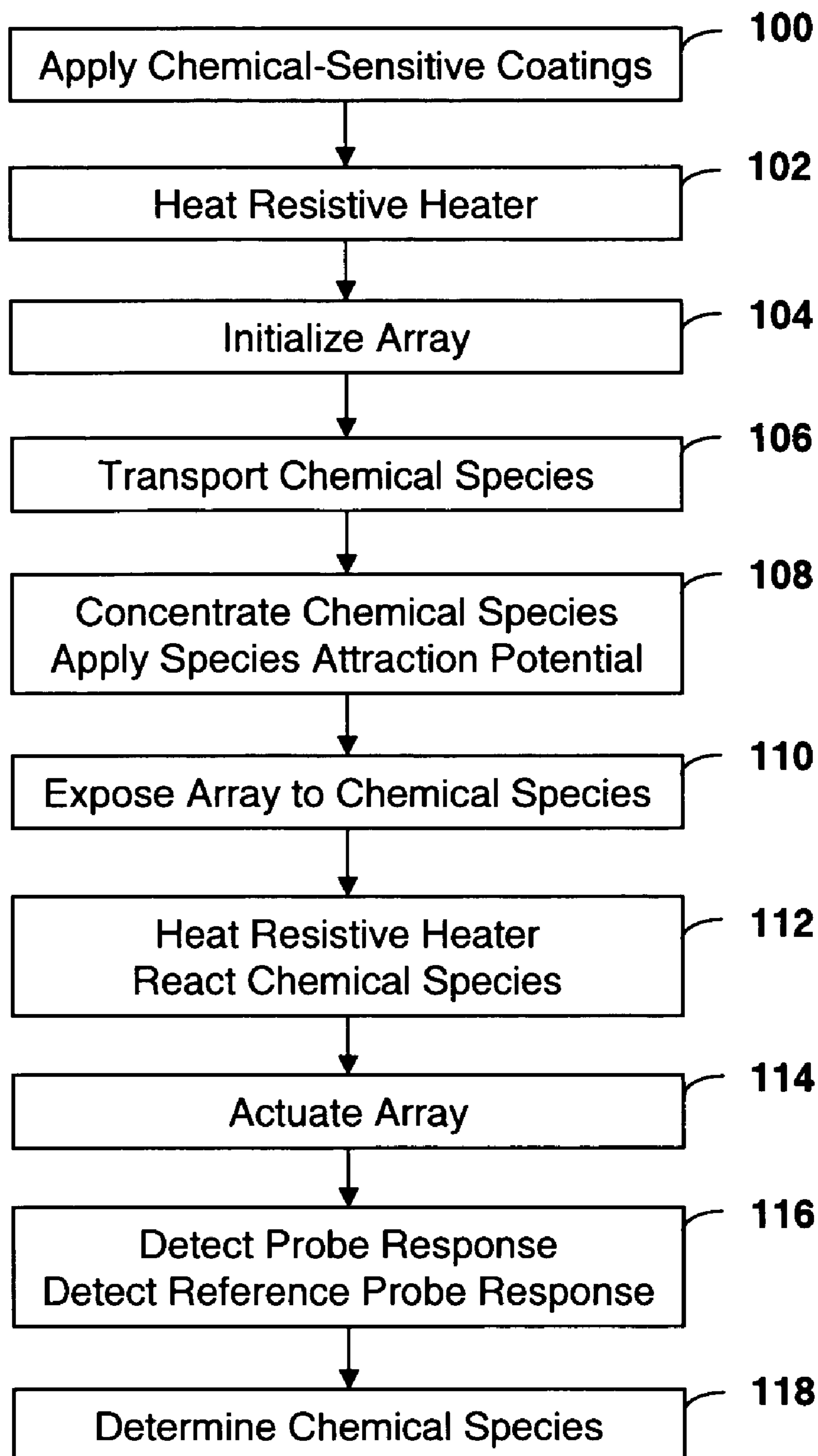
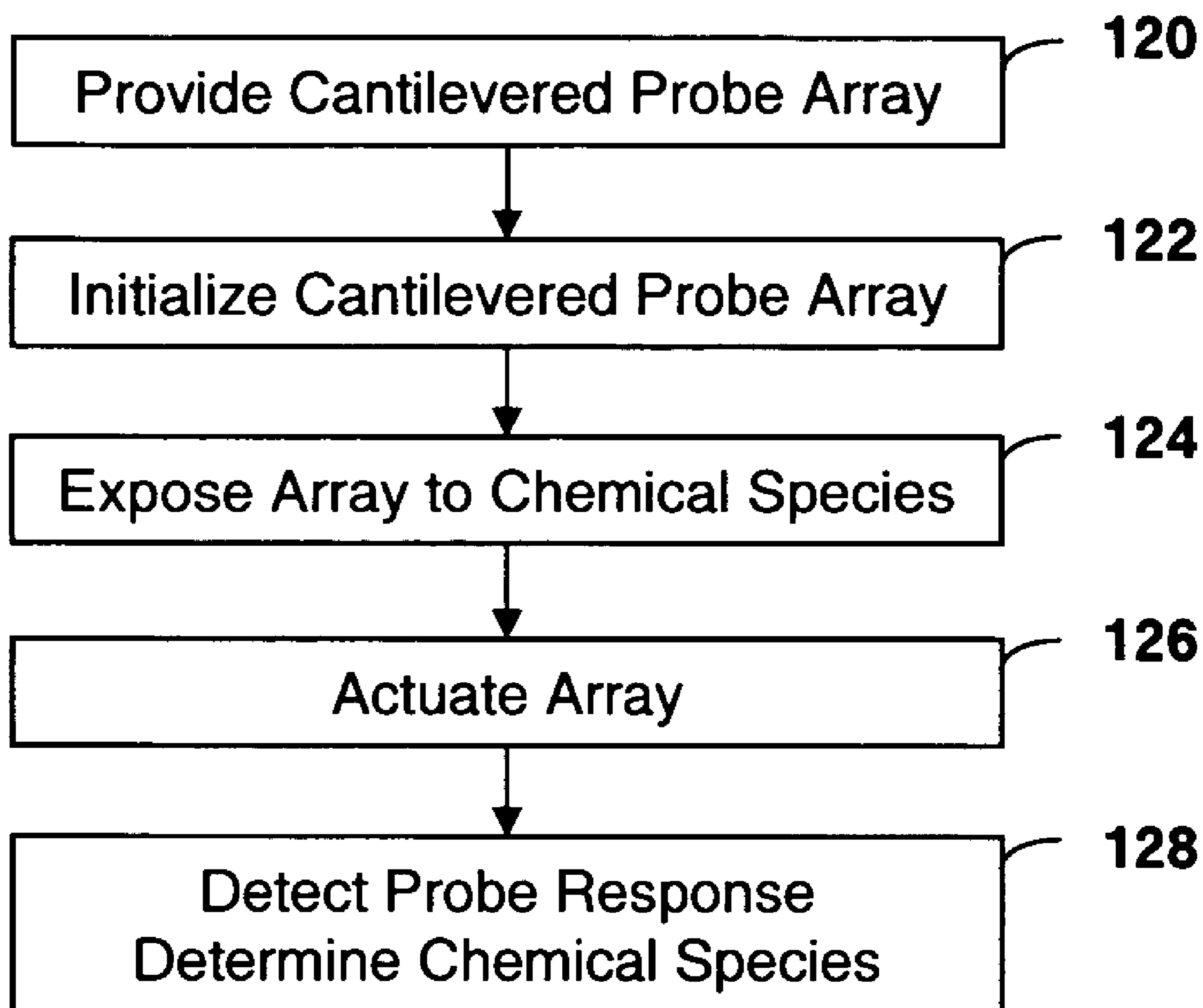

FIG. 11



SELF-SENSING ARRAY OF MICROCANTILEVERS FOR CHEMICAL DETECTION

CROSS-REFERENCE TO RELATED APPLICATIONS

[0001] This utility application claims the priority benefit of, and hereby incorporates by reference in its entirety, the applicant's prior U.S. Provisional Application No. 60/512,504, filed Oct. 17, 2004.

FIELD OF THE INVENTION

[0002] This invention relates generally to chemical-sensing methods, and in particular, relates to a method and system for sensing specific chemicals and biological materials using an array of piezoelectrically driven cantilevered probes with selectively disposed chemical-sensitive coatings.

BACKGROUND OF THE INVENTION

[0003] Micromachined cantilevers are used in atomic force microscopy (AFM) for surface scanning and for chemical, biological, and other sensing applications. Micromachined cantilevers may become the basis for specialized, ultraminiature, ultrasensitive sensors for detection of specific target chemical species such as chemical compounds, bioactive agents, or toxins. Miniaturized chemical sensors hold promise for applications needing sensitive chemical detection, quality control of materials processing, and measurements of small or limited quantities of a chemical or biological material. Resonance-based detection has been demonstrated specifically for sensing mercury vapor, ultraviolet radiation, relative humidity, magnetic susceptibility, and sub-nanogram masses.

[0004] AFM is a method of measuring surface topography on a scale typically from a few angstroms or less to a hundred micrometers or more. The technique involves imaging a sample through the use of a probe or tip suspended from one end of a microcantilever. A surface is probed with the tip, and the interaction between the tip and sample is measured. Physical topography, surface chemistry, charge density, magnetic properties, local temperature and other surface properties can be analyzed.

[0005] Lasers can be used for optical detection of cantilever movement, though AFM systems using lasers require comparably high power on the order of milliwatts, need alignment, have limited resolution, and are prone to drift because of the size of the optical path. Current systems typically require external lighting for sample illumination and setup, and are not very compact because of the long optical path, the need to have the photodetector at an ample distance from the sample, and constrained viewing and positioning systems for optical alignment. Sample testing in liquids such as water or saline solution presents additional difficulties for optical sensing due to aberrations and refraction of the light beam traversing the fluid.

[0006] Lasers have been used to detect frequency changes of a microcantilever that is oscillated by a piezoelectric transducer, as taught in "Microbar Sensor," Wachter et al., U.S. Pat. No. 5,445,008 issued Aug. 29, 1995. Oscillation frequency changes are detected by a center-crossing photodiode that responds to a laser diode beam reflected from the

microcantilever surface resulting in an output frequency from the photodiode that is synchronous with the microcantilever frequency.

[0007] AFM systems using microcantilevers and laser detection have been used for analyzing explosive gas molecules adsorbed onto the microcantilevers, as described in "Microcantilever Detector for Explosives," Thundat, U.S. Pat. No. 5,918,263 issued Jun. 29, 1999. Analysis can be made of the laser beam reflected by the heat-induced deflection and transient resonant response of the microcantilever.

[0008] Because power efficiency is important to the size, lifetime, and utility of a cantilever sensor, alternative detection schemes to those using lasers have been proposed. Notably, capacitive systems are being developed to monitor cantilever deflection. While a low-power option, capacitive cantilever sensing is most suitable under vacuum conditions to avoid excessive air damping between the two electrodes of the capacitor. Other limitations of capacitive schemes include small tolerances for fabrication and coatings of a cantilever, a reliance on a small sensing gap size, and difficulties with sensing in liquid solutions.

[0009] In an alternative sensing scheme to optical detection or capacitive sensing, AFM systems in a vibrating or tapping mode may use actuated piezoresistive cantilevers. Piezoresistive sense methods are more compact than optical systems, though they can self-heat and cause drift. Furthermore, piezoresistive sensing typically consumes large portions of available power when used in a portable device. A typical piezoresistive cantilever, which also can use milliwatts of power, is a micro-electrical-mechanical-system (MEMS) device, micromachined from bulk silicon with a piezoelectric film patterned along a portion of the microcantilever. At the free end of the cantilever is a tip with nanometer-scale radius, optimally shaped to probe the sample surface. The microcantilever is displaced by voltage applied to the piezoelectric actuator, resulting in a controlled vertical movement of the tip. Control electronics drive the microcantilever while simultaneously positioning it vertically to track the sample topography and follow the surface features. A macro-scale position actuator may be used to null the position of the cantilever, following the topology of the sample as the probe is scanned over the surface.

[0010] Chemicals can be sensed based on frequency shifts of microcantilevers treated with a compound-selective substance, as disclosed in "Microcantilever Sensor," Thundat et al., U.S. Pat. No. 5,719,324 issued Feb. 17, 1998. A microsensor with a cantilever attached to a piezoelectric transducer is capable of detecting changes in the resonance frequency and the bending of the vibrated cantilever in a monitored atmosphere. Upon insertion into a monitored atmosphere, molecules of a targeted chemical to be sensed attach to the treated regions of the microcantilever resulting in a change in oscillating mass as well as a change in microcantilever spring constant thereby influencing the resonant frequency of the microcantilever oscillation.

[0011] Oscillating silicon nitride cantilevered beams coated with a thin gold film have been used to detect mercury vapor in air due to changes in cantilever resonant frequency and stress levels induced in the gold overlayer as described by Thundat, et al., in "Detection of Mercury Vapor Using Resonating Microcantilevers," *Appl. Phys. Lett.* 66 (13), 27 Mar. 1995, pp. 1695-1697. An uncoated microcan-

tilever can be used for chemical sensing by exciting charge carriers into or out of surface states with discrete photon wavelengths as disclosed by Thundat, et al., in "Uncoated Microcantilevers as Chemical Sensors," U.S. Pat. No. 6,212,939, issued Apr. 10, 2001. Attempts at DNA sequencing and detection using an AFM is described by Allen in "Method and Apparatus for DNA Sequencing Using a Local Sensitive Force Detector," U.S. Pat. No. 6,280,939, issued Aug. 28, 2001.

[0012] An exemplary cantilever with a piezoelectric drive and a piezoresistive sense is disclosed in "Atomic Force Microscope for High Speed Imaging Including Integral Actuator and Sensor," Minne et al., U.S. Pat. No. 5,883,705 issued Mar. 16, 1999, and "Cantilever for Scanning Probe Microscope Including Piezoelectric Element and Method of Using the Same," Minne et al., U.S. Pat. No. 5,742,377 issued Apr. 21, 1998. When the scanning probe microscope (SPM) operates in the constant force mode, the piezoelectric element is used to control the tip-sample separation. Since the resonant frequency of the piezoelectric element is substantially higher than that of conventional piezoelectric tube scanners, much higher scan rates can be achieved. When the SPM operates in the dynamic or intermittent contact mode, a superimposed AC-DC signal is applied to the piezoelectric element, and the latter is used to vibrate the cantilever as well as to control the tip-sample spacing.

[0013] Piezoelectrically driven cantilevers have been proposed to eliminate the need for external actuators. An exemplary self-actuating cantilever is described in "Active Probe for an Atomic Force Microscope and Method of Use Thereof," Adderton et al., U.S. Pat. No. 6,530,266 issued Mar. 11, 2003 and "Atomic Force Microscope for High Speed Imaging Including Integral Actuator and Sensor," Adderton et al., U.S. Pat. No. 6,189,374 issued Feb. 20, 2001. This system includes a self-actuated cantilever having a Z-positioning element integrated therewith and an oscillator that oscillates the self-actuated cantilever at a frequency generally equal to a resonant frequency of the self-actuated cantilever.

[0014] In response to the growing interest in using cantilevers for chemical sensing, researchers are developing systems with multiple cantilever sensors or modular sensor array systems to characterize larger numbers of material samples more quickly. An example of a system of multiple cantilevers in a substantially linear configuration that uses individually-selectable cantilevers with a different resonance frequency for each is disclosed in "Multiprobe and Scanning Probe Microscope," Shimizu et al., U.S. Pat. No. 6,469,293 issued Oct. 22, 2002. A modular sensor array system has been suggested for rapid deposition of sample chemicals on sensor arrays in "Sensor Array-Based System and Method for Rapid Materials Characterization," Mansky et al., U.S. Pat. No. 6,535,824, issued Mar. 18, 2003 and "Sensor Array for Rapid Materials Characterization," Mansky et al., U.S. Pat. No. 6,535,822, issued Mar. 18, 2003. One intended goal is to eliminate the need for multiple materials characterization machines and the need for application-specific active circuitry within the sensor arrays themselves.

[0015] In light of the discussion above, an improved system for sensing chemicals is desirable that is more compact and power-efficient than piezoresistively or opti-

cally sensed AFM cantilevers, does not require off-chip actuation for frequency measurements, does not require individual addressing of each cantilever to determine the natural frequencies, is capable of operating in liquid or gas, and generates less unwanted heat than other AFM cantilever systems. Cantilevers need to be small and light for rapid detection of minute concentrations of target chemicals and biomaterials. Therefore, a desirable method and system for chemical sensing incorporates these improvements and overcomes the deficiencies described above.

SUMMARY OF THE INVENTION

[0016] One aspect of the invention provides a chemical detection system for detecting at least one target chemical species. The system includes a self-sensed cantilevered probe array with a plurality of self-sensed cantilevered probes; one or more chemical-sensitive coating materials applied to at least one cantilevered probe in the cantilevered probe array; and an interface circuit coupled to the cantilevered probe array. One or more chemical-sensitive coated cantilevered probes in the cantilevered probe array exhibit a shifted cantilevered probe response when the cantilevered probe array is exposed to the target chemical species and is actuated by the interface circuit.

[0017] Another aspect of the invention is a method of chemical detection. A self-sensed cantilevered probe is exposed to a target chemical species and the exposed cantilevered probe array is actuated. A cantilevered probe response from at least one self-sensed cantilevered probe in the cantilevered probe array is detected, and the target chemical species is determined based on the detected cantilevered probe response.

[0018] Another aspect of the invention is a handheld system for sensing a target chemical species including an enclosure, a self-sensed cantilevered probe array coupled to the enclosure, at least one chemical-sensitive coating material applied to at least one cantilevered probe in the cantilevered probe array, and an interface circuit coupled to the cantilevered array. The enclosure includes an inlet port for the ingress of the target chemical species and an outlet port for the egress of the target chemical species. The cantilevered probe array includes a plurality of self-sensed cantilevered probes. At least one cantilevered probe in the cantilevered probe array exhibits a shifted cantilevered probe response when the cantilevered probe array is exposed to the target chemical species and is actuated by the interface circuit.

BRIEF DESCRIPTION OF THE DRAWINGS

[0019] The current invention is illustrated by the accompanying drawings of various embodiments and the detailed description given below. The drawings should not be taken to limit the invention to the specific embodiments, but are for explanation and understanding. The detailed description and drawings are merely illustrative of the invention rather than limiting, the scope of the invention being defined by the appended claims and equivalents thereof. The foregoing aspects and other attendant advantages of the present invention will become more readily appreciated by the detailed description taken in conjunction with the accompanying drawings. Various embodiments of the present invention are illustrated by the accompanying figures, wherein:

[0020] FIG. 1 illustrates a chemical detection system for detecting at least one target chemical species, in accordance with one embodiment of the current invention;

[0021] FIG. 2 illustrates a self-sensed cantilevered probe array, in accordance with one embodiment of the current invention;

[0022] FIG. 3 is a schematic diagram of a cantilevered probe array with series-connected cantilevered probes electrically connected to a pair of cantilevered probe array drive pads, in accordance with one embodiment of the current invention;

[0023] FIG. 4 is a schematic diagram of a cantilevered probe array with parallel-connected cantilevered probes electrically connected to a pair of cantilevered probe array drive pads, in accordance with one embodiment of the current invention;

[0024] FIG. 5 is a schematic diagram of a cantilevered probe array with a network of series-connected and parallel-connected cantilevered probes electrically connected to a pair of cantilevered probe array drive pads, in accordance with one embodiment of the current invention;

[0025] FIG. 6a is a schematic diagram of a controller and an interface circuit connected to a self-sensed cantilevered probe array, in accordance with one embodiment of the current invention;

[0026] FIG. 6b is a plot of cantilevered probe responses from a self-sensed cantilevered probe array scanned through a predetermined frequency range, in accordance with one embodiment of the current invention;

[0027] FIG. 7 illustrates a method for applying a chemical-sensitive coating material to a cantilevered probe array with a mask, in accordance with one embodiment of the current invention;

[0028] FIG. 8 illustrates a top view of a self-sensed cantilevered probe including a selectively deposited coating, a heater, and a species attraction electrode;

[0029] FIG. 9 illustrates a handheld system for sensing a target chemical species, in accordance with one embodiment of the current invention;

[0030] FIG. 10 is a flow chart of a method for chemical detection, in accordance with one embodiment of the current invention; and

[0031] FIG. 11 is a flow chart of a method for chemical detection, in accordance with another embodiment of the current invention.

DETAILED DESCRIPTION OF THE INVENTION

[0032] FIG. 1 illustrates a chemical detection system for detecting at least one target chemical species, in accordance with one embodiment of the present invention. The chemical detection system 10 includes a self-sensed cantilevered probe array 20 with a plurality of self-sensed cantilevered probes 30. Self-sensed cantilevered probes have suspended cantilevered elements with a piezoelectric drive 32 comprised of a deposited layer of zinc oxide (ZnO), lead zirconate titanate (PZT), or other piezoelectric material that bends, deflects and vibrates the cantilevered element when

excited or actuated with an applied drive voltage. The piezoelectric material generates a voltage as the cantilevered probes bend or vibrate, and can be used to sense cantilevered probe motions as well as drive cantilevered probes 30, referred to herein as self-sensing. At least one chemical-sensitive coating material 34 is applied to one or more cantilevered probes 30 in cantilevered probe array 20 to allow for chemical detection and specificity. One or more cantilevered probes 30 in cantilevered probe array 20 is coated or otherwise treated to detect target chemical species 12. An interface circuit 40, which is coupled to cantilevered probe array 20, actuates and senses motions of cantilevered probes 30. When cantilevered probe array 20 is exposed to a target chemical species 12 and is actuated by interface circuit 40, one or more cantilevered probes 30 in cantilevered probe array 20 exhibit a shifted cantilevered probe response.

[0033] Cantilevered probes 30 in cantilevered probe array 20 are frequency-differentiated such that cantilevered probes 30 having different masses or effective spring constants exhibit different resonant frequencies. Cantilevered probes 30 can be manufactured, for example, with small differences in cantilever lengths, resulting in separations in resonant frequencies so that the resonant frequency of each cantilevered probe 30 in an array is able to be detected with as few as two wires connected to cantilevered probe array 20. Thus, cantilevered probe arrays 20 with two or more cantilevered probes 30 can be packaged and connected to interface circuit 40 with a minimal number of bond pads, interconnection traces and bond wires to external interface and control electronics. Parallel arrays of cantilevered probes 30 can be configured with elements that number from a few to massively parallel arrays with a million or more cantilevered probes 30 on one substrate or die. Groups of cantilevered probe arrays 20 may be connected during on-chip trace definition, while wire-bonding to a leadframe or package, or at the socket or board level.

[0034] Non-overlapping, independent and orthogonal chemical-sensing effects on individual cantilevered probes 30 in cantilevered probe array 20 may be desirable but not necessary when many cantilevered probes 30 with various coatings and coating thicknesses are used for detection. Signal processing and pattern recognition of the resonance-frequency data from multiple cantilever probes 30 may be employed to differentiate between various target chemical species in varying concentrations having sometimes small and sometimes null effects. Differentiation between similar chemical substances can be made and their constituency and concentration can be determined in a system where a variety of coatings are applied to multiple cantilevered probes 30. Chemical detection system 10 can detect one or more target chemical species 12 such as mercury, hydrogen, an alcohol, water vapor, an explosive material, a chemical element, a chemical compound, an organic material, an inorganic material, a gaseous substance, a liquid, a biological material, a DNA strand, a bioactive agent, a toxin, and a combination thereof. Chemical species refers to any chemical or biological material.

[0035] One or more cantilevered probes 30 respond when exposed to target chemical species 12. Cantilevered probes 30 may respond by absorbing, adsorbing, or otherwise reacting to target chemical species 12. When exposed to target chemical species 12, cantilevered probes 30 may

increase or decrease in mass, or become more rigid or less rigid. In one example, cantilevered probe 30 comprises a patterned layer of gold. When exposed to mercury, the two react to form an amalgam. The gold-mercury amalgam adds mass to cantilevered probe 30 and therefore tends to decrease the resonant frequency of cantilevered probe 30. Amalgam formation, however, increases the mechanical stiffness of cantilevered probe 30 thereby increasing its natural resonant frequency. The two effects tend to cancel each other, though one effect can be made dominant by careful selection and placement of chemical-sensitive coating material 34 on cantilevered probe 30.

[0036] Target chemical species 12, which may be located in a liquid or gas carrier 14 such as air or water, in a low-pressure gas, or a plasma, are transported in a forced or free manner towards cantilevered probes 30 where they contact surfaces of cantilevered probes 30 and invoke shifts in resonant frequency, Q factor, impedance, or deflection amplitudes.

[0037] Cantilevered probe array 20 is actuated with an excitation voltage applied to piezoelectric drive 32 disposed on each cantilevered probe 30 in cantilevered probe array 20. To reduce the number of external connections, a group of cantilevered probes 30 may be connected in series and electrically connected to a pair of cantilevered probe array drive pads 24, which in turn is electrically connected to interface circuit 40. While this configuration can increase the series resistance of the string, differentiation of individual cantilevered probes 30 may be made with detection of signals at or near the resonant frequency of selected cantilevered probe 30. Alternatively, a group of cantilevered probes 30 may be connected in parallel and electrically connected to a pair of cantilevered probe array drive pads 24, increasing the effective capacitance and decreasing the effective resistance, while still allowing differentiation of individual cantilevered probe responses based on frequency. Alternatively, cantilevered probes 30 may be connected in a network of series-connected and parallel-connected cantilevered probes with frequency-identifiable addressable elements.

[0038] Interface circuit 40 provides excitation voltages for the piezoelectric material on cantilevered probes 30 and senses deflections and vibrations of cantilevered probes 30 with the same piezoelectric material. In one example, interface circuit 40 includes an adjustable frequency generator that is scanned through a predetermined frequency range to excite one or more cantilevered probes 30 in cantilevered probe array 20. In another example, interface circuit 40 includes an impedance analyzer that is scanned through a resonant frequency of at least one cantilevered probe 30, measuring the magnitude and phase from cantilevered probes 30 and monitoring for any variations in the impedance as cantilevered probes 30 are exposed to one or more target chemical species 12. In another example, interface circuit 40 includes an oscillator circuit operating at a resonant frequency of at least one cantilevered probe 30 in cantilevered probe array 20. In another example, interface circuit 40 includes an oscillator circuit operating at a predetermined frequency that is near, yet off-resonance with respect to one or more cantilevered probes 30 in cantilevered probe array 20, so that as the resonant frequency of the selected cantilevered probe 30 shifts, a large output signal can be obtained as the resonant frequency shifts and moves

towards the predetermined frequency, resulting in higher amplitudes of vibration and therefore higher output signals. The predetermined frequency may be set, for example, slightly above or slightly below the resonant frequency of one of cantilevered probes 30. In another example, the amplitude of bending and vibration is monitored as cantilevered probe 30 strikes against a fixed or adjustable mechanical stop such as a piezoelectric slab or a piezotube. In another example, interface circuit 40 includes an impulse circuit for applying an electrical impulse to cantilevered probe array 20, and ring-down of cantilever probes 30 is monitored. In another example, noise such as pink noise or white noise is applied to excite cantilevered probe array 20. In another example, interface circuit 40 includes a network analyzer for detecting signals from cantilevered probe array 20. Interface circuit 40 or controller 50 may include a fast Fourier transform generator to perform a fast Fourier transform (FFT) on the shifted cantilevered probe response and provide respective frequencies of cantilevered probes 30 in cantilevered probe array 20 for correlation with previously measured probe responses and determination of target chemical species 12.

[0039] Interface circuit 40 detects shifted cantilevered probe responses from one or more actuated cantilevered probes 30 in cantilevered probe array 20. Shifted cantilevered probe responses include, for example, a shift in a resonant frequency of one or more cantilevered probes 30, a shift in a quality (Q) factor of one or more cantilevered probes 30, a shift in impedance of one or more cantilevered probes 30, a shift in deflection amplitude of one or more cantilevered probes 30, or a combination thereof. With exposure to target chemical species 12, one or more cantilevered probes 30 in cantilevered probe array 20 can exhibit shifts. Similarly, with exposure to more than one target chemical species 12, one or more cantilevered probes 30 in cantilevered probe array 20 may exhibit shifts from which multiple target chemical species 12 can be determined.

[0040] A controller 50 such as a central processing unit (CPU), a digital signal processor (DSP), a microcontroller, or a field-programmable gate array (FPGA) may be included in chemical detection system 10 to execute programmed code and provide monitoring, controlling and analyzing functions. Controller 50 is in electrical communication with interface circuit 40 and may be located, for example, on substrate 22 along with cantilevered probe array 20, within enclosure 60 on the same circuit board or in the same package as cantilevered probe array 20, or located remotely with respect to enclosure 60. Controller 50 may internally contain the functions and capabilities of interface circuit 40. Controller 50 receives shifted cantilevered probe responses from a set of one or more cantilevered probes 30 in cantilevered probe array 20. Target chemical species 12 may be determined based on the shifted cantilevered probe response using, for example, an algebraic model that relates shifts in cantilevered probe responses to target chemical species and concentration. Alternatively, target chemical species 12 may be determined based on a comparison between the shifted cantilevered probe responses and a reference set of cantilevered probe responses. Such reference sets can be obtained by exposing cantilevered probes 30 to controlled environments with known target chemical species and concentrations during calibration at the factory or on site. Controller 50 can determine one or more target chemical species 12 through pattern recognition techniques, statistical processes,

and fuzzy logic with comparison to the reference set of cantilevered probe responses. The reference set of cantilevered probe response comprises, for example, a learned set obtained from shifts in cantilevered probe responses by cantilevered probes 30 that are exposed to known target chemical species and concentrations under controlled laboratory or factory environments.

[0041] Chemical-sensitive coating material 34 is applied to at least a portion of one or more cantilevered probes 30 of cantilevered probe array 20. For example, chemical-sensitive coating material 34 may be applied to the topside or bottom side of one or more cantilevered probes 30 or to portions thereof. Chemical-sensitive coating material 34 includes, for example, an epoxy resin such as Novolac™, a fluoropolymer such as FluoroPel™, a gold layer, a palladium layer, an alcohol-absorbent polymer, a water-absorbent material, a chemical-sensitive polymer, a chemical-sensitive layer, a biosensitive material, a thiol, and combinations thereof.

[0042] Various application methods are used to deposit or apply coating materials and to treat surfaces of cantilevered probes 30. Chemical-sensitive coating materials 34 comprise, for example, a dipped coating, a sprayed coating, or a dispensed coating disposed on at least a portion of one or more cantilevered probes 30. An exemplary chemical-sensitive coating material 34 includes a masked coating disposed on a portion of one or more cantilevered probes 30. In an alternative application method, a non-homogeneous coating material is applied to a set of cantilevered probes 30 in cantilevered probe array 20, such that constituents of the non-homogeneous coating material are deposited on cantilevered probes 30 with suitable variations in composition, coverage, and thickness.

[0043] In one embodiment of the present invention, chemical detection system 10 includes one or more reference cantilevered probes in the cantilevered probe array. The reference cantilevered probe provides a reference cantilevered probe response when cantilevered probe array 20 is exposed to target chemical species 12. Reference cantilevered probes are formed, for example, with no coating materials disposed thereon to reduce or eliminate sensitivity to target chemical species 12. Alternatively, reference cantilevered probes have an inert coating disposed on the surface to reduce or eliminate sensitivity to target chemical species 12. Alternatively, one or more reference cantilevered probes are mechanically isolated from exposure to target chemical species 12 while other portions of cantilevered probe array 20 are exposed.

[0044] In cases where heating of select cantilevered probes 30 burns off, evaporates off, or otherwise cleans and resets cantilevered probe 30 to a nascent condition, a resistive heater 36 may be coupled to at least one cantilevered probe 30 in the cantilevered probe array 20. Resistive heater 36 may be formed with a resistive layer disposed on the surface of or formed within cantilevered probe 30. Exemplary resistive heaters 36, which may be connected in series or parallel or individually connected are formed on one, several, or all cantilevered probes 30 within cantilevered probe array 20. Resistive heaters 36 also may be used to react a target chemical species on cantilevered probe 30 by heating the probe to a predetermined temperature where the

reaction can occur. Alternatively, resistive heaters 36 may be used to ignite or deflagrate condensate of explosive vapors on cantilevered probes 30.

[0045] Species attraction electrodes 38 disposed on cantilevered probes 30 can be used to apply voltage to preferentially attract target chemical species 12 or to allow the monitoring of electrochemical reactions in the vicinity of cantilevered probes 30. Species attraction electrodes 38, which may be disposed on one or more cantilevered probes 30 in cantilevered probe array 20, allow the application of a species attraction potential.

[0046] Exemplary chemical detection system 10 contains one or more cantilevered probe arrays 20 in an enclosure 60, which includes an inlet port 62 and an outlet port 64 for transport of target chemical species 12 and carriers 14. Target chemical species 12 enters enclosure 60 through inlet port 62 and is exposed to cantilevered probe array 20. Target chemical species 12 or by-products thereof exit through outlet port 64. Enclosure 60 may include filters, scrubbers, and other media treatment elements to aid in the detection of target chemical species 12.

[0047] A transport mechanism 66 such as a pump or a fan with ductwork or piping may be included for transporting target chemical species 12 to cantilevered probe array 20.

[0048] A concentrator 68 such as a pressurizing system or a condenser and heater system may be included to concentrate target chemical species 12 proximal to cantilevered probe array 20 for detection of target chemical species 12.

[0049] Chemical detection system 10 may be connected to a local area network (LAN), a wide area network (WAN), the Internet, or other networked communication system via one or more wired or wireless connections.

[0050] Chemical detection system 10 may be installed, for example, into an air handling system of a building or airport that has many inlets, into a standalone unit with a portal for chemical detection, and into handheld units for portable use. Chemical detection system 10 may be installed in shipping containers and crates during storage and transit for chemical detection and monitoring.

[0051] FIG. 2 illustrates a self-sensed cantilevered probe array, in accordance with one embodiment of the present invention. Self-sensed cantilevered probe array 20 includes a plurality of cantilevered probes 30 on a substrate 22. At least one chemical-sensitive coating material 34 is applied to one or more cantilevered probes 30 in cantilevered probe array 20. Variations in length or thickness of cantilevered probes 30 and variations in the thickness and coverage of applied coatings allow frequency differentiation between cantilevered probes within cantilevered probe array 20.

[0052] Cantilevered probes 30 may have a rectangular shape, though other shapes may be suitably used such as a pointed cantilever, a V-shaped cantilever, a triangular-shaped cantilever, a dual-arm cantilever, or a balanced cantilever. Cantilevered probes 30 may be arranged and attached to substrate 22 in an array of cantilevered beams, the cantilevers being all identical, all different, or some combination thereof.

[0053] Cantilevered probe array 20 is actuated with an excitation voltage applied to a piezoelectric drive 32 of piezoelectric material disposed on each cantilevered probe

30. Cantilevered probes **30** may be series-connected to a pair of cantilevered probe array drive pads **24** on substrate **22**. Alternatively, cantilevered probes **30** may be parallel-connected to the pair of cantilevered probe array drive pads **24**. Alternatively, cantilevered probe array **20** may comprise a network of series-connected and parallel-connected cantilevered probes electrically connected to the pair of cantilevered probe array drive pads **24**. More than one group or array of cantilevered probes **30** may be included on substrate **22**. Substrate **22** may have through-wafer vias for backside connection.

[0054] Substrate **22** includes a semiconductor substrate such as a silicon wafer, a silicon-on-insulator (SOI) wafer, a glass substrate, or other suitable substrate for forming cantilevered probes **30** thereon. Cantilevered probes **30** comprise materials such as silicon, polysilicon, silicon nitride, a metal film, a metal sheet, a zinc oxide film, a PZT film, a polymeric layer, and combinations thereof. For example, a zinc oxide film is deposited on a layer of single-crystal silicon, patterned, and etched. Conductive layers for top and bottom electrodes, interconnections, and heater connections are deposited and etched accordingly. Definition of cantilevered probes **30** with a photomask and associated lithographic sequences along with deep reactive ion etching (DRIE) or anisotropic etching of the cantilevers and substrate allows the formation and freeing of silicon cantilevers with interconnected ZnO electrodes in series, parallel, and series-parallel configurations. Excitation and detection of the cantilevers occur with voltages applied to the piezoelectric material and detection thereof.

[0055] Chemical-sensitive coating material **34** is applied to at least a portion of one or more cantilevered probes **30**. The chemical-sensitive coating material includes, for example, an epoxy resin, a fluoropolymer, a gold layer, a palladium layer, an alcohol-absorbent polymer, a water-absorbent material, a chemical-sensitive polymer, a chemical-sensitive layer, a biosensitive material, a thiol, and a combination thereof. Chemical-sensitive coating material **34** may be applied, for example, with techniques such as dipping, spraying, or dispensing the coating on at least a portion of one or more cantilevered probes. The chemical-sensitive coating material may be applied onto a portion of one or more cantilevered probes with the use of stencil masks or photomasks and photolithographic patterning techniques. Chemical-sensitive coating material **34** may be applied, for example, using standard sputtering and other deposition techniques known in the art.

[0056] Multiple masking sequences can be used to apply multiple coating materials. Alternatively, multiple-component chemical-sensitive coating materials **34** may comprise a non-homogeneous coating material applied to a set of cantilevered probes **30** in the cantilevered probe array **20**, applied in such a way that variations in coating thickness and composition occur when they are deposited.

[0057] When exposed to target chemical species **12**, one or more cantilevered probes **30** in cantilevered probe array **20** may undergo an electrical or a mechanical shift, such as a shifted resonant frequency, a shifted Q factor, a shifted impedance, or a shifted deflection amplitude.

[0058] Cantilevered probe array **20** may include one or more reference cantilevered probes **30r** to provide a reference cantilevered probe response when cantilevered probe

array **20** is exposed to target chemical species **12**. For example, reference cantilevered probes may be uncoated, coated with an inert material, or otherwise protected from exposure to target chemical species **12**.

[0059] FIG. 3 is a schematic diagram of a cantilevered probe array with series-connected cantilevered probes electrically connected to a pair of cantilevered probe array drive pads, in accordance with one embodiment of the present invention. Two or more cantilevered probes **30** in a cantilevered probe array **20** are connected in series to a pair of cantilevered probe array drive pads **24**. Electrodes above and below the piezoelectric material on each cantilevered probe **30** are connected in series with electrodes above and below the piezoelectric material on other cantilevered probes **30** in the set. In the example illustrated, cantilevered probes **30a**, **30b**, . . . **30n** represent a plurality of series-connected cantilevered probes with piezoelectric drives **32a**, **32b**, . . . **32n** that are frequency-differentiated with fundamental resonant frequencies f_1 , f_2 , . . . f_n , respectively. Each cantilevered probe **30a**, **30b**, . . . **30n** may have one or more chemical-sensitive coating materials **34a**, **34b**, . . . **34n** coated thereon. When activated, for example, with an interface circuit (not shown) that scans through the resonant frequencies of one or more cantilevered probes, each cantilevered probe within the scanned frequency range is, in turn, excited and oscillated by the interface circuit as the frequency of the oscillator or frequency generator is scanned through its resonant frequency. Multiple groups of series-connected cantilevered probes **30** may be further connected in series or in parallel to cantilevered probe array drive pads **24** or to other sets of drive pads.

[0060] FIG. 4 is a schematic diagram of a cantilevered probe array with parallel-connected cantilevered probes electrically connected to a pair of cantilevered probe array drive pads, in accordance with one embodiment of the present invention. Two or more cantilevered probes **30** are connected in parallel to a pair of cantilevered probe array drive pads **24**. Electrodes above and below the piezoelectric material on each cantilevered probe **30** are connected in parallel with electrodes above and below the piezoelectric material on other cantilevered probes **30** in the set. In the example illustrated, cantilevered probes **30a**, **30b**, . . . **30n** represent a plurality of parallel-connected cantilevered probes with piezoelectric drives **32a**, **32b**, . . . **32n** that are frequency-differentiated with fundamental resonant frequencies f_1 , f_2 , . . . f_n , respectively. Each cantilevered probe **30a**, **30b**, . . . **30n** may have one or more chemical-sensitive coating materials **34a**, **34b**, . . . **34n** coated thereon. When activated, for example, with an interface circuit (not shown) that scans through the resonant frequencies of one or more cantilevered probes, each cantilevered probe is, in turn, excited and oscillated by the interface circuit as the frequency of the oscillator or frequency generator is scanned through the resonant frequency. Multiple groups of parallel-connected cantilevered probes **30** may be further connected in series or in parallel to cantilevered probe array drive pads **24** or to other sets of drive pads.

[0061] FIG. 5 is a schematic diagram of a cantilevered probe array with a network of series-connected and parallel-connected cantilevered probes electrically connected to a pair of cantilevered probe array drive pads, in accordance with one embodiment of the present invention. A plurality of cantilevered probes **30** is connected in a network of series

and/or parallel sets of cantilevered probes **30** to a pair of cantilevered probe array drive pads **24**. In the example illustrated, cantilevered probes **30a**, **30b**, . . . **30n** represent series-connected and parallel-connected cantilevered probes with piezoelectric drives **32a**, **32b**, . . . **32n** that are frequency-differentiated with fundamental resonant frequencies f_1 , f_2 , . . . f_n . Each cantilevered probe **30a**, **30b**, . . . **30n** may have one or more chemical-sensitive coating materials **34a**, **34b**, . . . **34n** coated thereon. When activated, for example, with an interface circuit (not shown) that scans through the resonant frequencies of one or more cantilevered probes **30**, each cantilevered probe **30** is, in turn, excited and oscillated by the interface circuit as the frequency of the oscillator or frequency generator is scanned through the resonant frequency. Multiple groups of networked cantilevered probe arrays **20** may be located on the same substrate and connected to other pairs of drive pads.

[0062] FIG. 6a is a schematic diagram of a controller and an interface circuit connected to a self-sensed cantilevered probe array, in accordance with one embodiment of the present invention. Controller **50** is connected to interface circuit **40** that drives and senses a plurality of self-sensed cantilevered probes **30** in a cantilevered probe array **20**. It should be observed that cantilevered probe array **20** may be electrically connected to interface circuit **40** with as few as two cantilevered probe array drive pads **24**. At least one cantilevered probe **30** in cantilevered probe array **20** exhibits a shifted cantilevered probe response when cantilevered probe array **20** is exposed to target chemical species **12** and cantilevered probe array **20** is actuated by interface circuit **40**.

[0063] Interface circuit **40** actuates cantilevered probe array **20** with an excitation voltage applied to a piezoelectric material disposed on each cantilevered probe **30** in the cantilevered probe array **20**. In one example, interface circuit **40** includes an adjustable frequency generator that is scanned through a predetermined frequency range. In another example, interface circuit **40** includes an impedance analyzer that is scanned through a resonant frequency of one or more cantilevered probes **30** in cantilevered probe array **20**. In another example, interface circuit **40** includes an oscillator circuit operating at a resonant frequency of at least one cantilevered probe in the cantilevered probe array. In another example, interface circuit **40** includes an oscillator circuit operating at a predetermined frequency that is set to be off-resonance with respect to at least one cantilevered probe **30** in cantilevered probe array **20**. In another example, interface circuit **40** includes control circuitry to monitor the amplitude of bending and vibration as cantilevered probe **30** strikes against a fixed or adjustable mechanical stop. In another example, interface circuit **40** comprises an impulse circuit for applying an electrical impulse to all cantilevered probes **30** in cantilevered probe array **20**. In another example, interface circuit **40** or controller **50** includes a fast Fourier transform generator to perform a fast Fourier transform on the shifted cantilevered probe response. Interface circuit **40** detects a shifted cantilevered probe response from one or more actuated cantilevered probes **30** such as a shifted resonant frequency, a shifted Q factor, a shifted impedance, or a shifted deflection amplitude.

[0064] Controller **50** receives a shifted cantilevered probe response from a set of one or more cantilevered probes **30** in cantilevered probe array **20**. The target chemical species

is determined based on the shifted cantilevered probe response. For example, the target chemical species may be determined based on a comparison between the shifted cantilevered probe response and a reference set of cantilevered probe responses. The reference set of cantilevered probe responses comprises, for example, a learned set obtained during the calibration of the chemical-sensing system or from a statistical database of cantilevered probe responses.

[0065] To cancel out common mode effects such as temperature, one of the cantilevered probes **30** in the cantilevered probe array **20** may be a reference cantilevered probe **30r**, wherein the reference cantilevered probe **30r** provides a reference cantilevered probe response when cantilevered probe array is exposed to target chemical species **12**.

[0066] FIG. 6b shows an illustrative plot of cantilevered probe responses from a self-sensed cantilevered probe array scanned through a predetermined frequency range, in accordance with one embodiment of the present invention. When activated, for example, with an interface circuit that scans through the resonant frequencies of one or more cantilevered probes, each cantilevered probe is, in turn, excited and oscillated by the interface circuit as the frequency of the oscillator or frequency generator is scanned through the resonant frequency. Depending on the type and amount of a target chemical species and the coating on the cantilevered probe, the cantilevered probes in the array may exhibit shifted cantilevered probe responses such as a shifted resonant frequency, a shifted Q factor, a shifted impedance, a shifted deflection amplitude, or a combination thereof.

[0067] Output curve **90** shows exemplary output signals from an array of cantilevered probes excited through a frequency range that includes a resonant frequency of each of the cantilevered probes in the array. Output curve **90** shows a baseline or reference set of resonant peaks **90a**, **90b**, **90c**, **90d**, **90e**, **90f**, **90g** and **90n** corresponding to a set of eight frequency-differentiated cantilevered probes with nominally equal frequency separations between the cantilevered probes. When the cantilevered probe array is exposed to a target chemical species and is actuated by the interface circuit, at least one cantilevered probe in the cantilevered probe array exhibits a shifted cantilevered probe response.

[0068] Exemplary output curve **92** shows resonant peaks **92a**, **92b**, **92c**, **92d**, **92e**, **92f**, **92g** and **92n** corresponding to the set of eight frequency-differentiated cantilevered probes after exposure to one or more target chemical species. In the example illustrated, resonant peak **92a** of the first cantilevered probe is shifted downwards from resonant peak **90a** after chemical exposure. Resonant peak **92b** of the second cantilevered probe is shifted higher than resonant peak **90b**. Resonant peak **92c** of the third cantilevered probe remains the same as resonant peak **90c**. Resonant peak **92d** of the fourth cantilevered probe has a lower Q factor than resonant peak **90d** after chemical exposure. Resonant peak **92e** of the fifth cantilevered probe has a higher Q factor than resonant peak **90e** after chemical exposure. Resonant peak **92f** has an amplitude less than that of resonant peak **90f** after chemical exposure, and resonant peak **92g** has an amplitude greater than that of resonant peak **90g** after chemical exposure. Resonant peak **92n** exhibits a combination of shifts in frequency, Q factor and amplitude after chemical exposure.

[0069] An additional resonant peak **92r** corresponding to a reference cantilevered probe shows no change in cantile-

vered probe response after exposure to the target chemical species compared to resonant peak **90r** corresponding to the reference cantilevered probe prior to exposure.

[0070] **FIG. 7** illustrates a chemical-sensitive coating material applied to a cantilevered probe array with a mask, in accordance with one embodiment of the present invention. A stencil mask **80** including at least one aperture **82** is positioned on or above a surface of a self-sensed cantilevered probe array **20** having a plurality of self-sensed cantilevered probes **30**. A chemical-sensitive coating material **34** is selectively applied to cantilevered probe array **20** through apertures **82**. In the example shown, cantilevered probes **30a**, **30b**, . . . **30n** are selectively coated with chemical-sensitive coating material **34** by spraying the material through stencil mask **80** and then drying chemical-sensitive coating material **34a**, **34b**, . . . **34n** on cantilevered probes **30a**, **30b**, . . . **30n**, respectively. A reference cantilevered probe **30r** is shown with no coating, having been masked with stencil mask **80** during spraying.

[0071] In this example, cantilevered probes **30a**, **30b**, . . . **30n** are nominally the same size and thickness. Frequency differentiation for this set of cantilevered probes is achieved by varying the area of the cantilevered probes that is covered by the coating. An angled aperture **82** in stencil mask **80** allows different amounts of coating material to be disposed on each cantilevered probe, varying the mass on each cantilevered probe and thereby changing the resonant frequencies accordingly. Stencil mask **80** may be used to cover cantilevered probe array drive pads **24** and other portions of substrate **22** that need not be coated. Piezoelectric drives **32** on cantilevered probes **30a**, **30b**, . . . **30n** and **30r**, respectively, may be coated, partially coated, or uncoated with chemical-sensitive coating materials **34**.

[0072] **FIG. 8** illustrates a top view of a self-sensed cantilevered probe including a selectively deposited coating, a heater, and a species attraction electrode. A resistive heater **36** is disposed on or formed in cantilevered probe **30**. Resistive heater **36** allows cantilevered probe **30** to be heated, for example, to initialize cantilevered probe **30** prior to exposing cantilevered probe array **20** to the target chemical species. In another role, resistive heater **36** may be used to burn off, deflagrate, or otherwise react a target chemical species that deposits on a surface of cantilevered probe **30**.

[0073] In another embodiment, a species attraction electrode **38** may be disposed on cantilevered probe **30** of cantilevered probe array **20** to allow a species attraction potential to be applied. Species attraction electrode **38** is positioned, for example, underneath or adjacent to chemical-sensitive coating material **34**. Electrical connections to species attraction electrode **38** may be made with, for example, one end of piezoelectric drive **32**, one end of resistive heater **36**, or with a connection to an independent electrical trace on substrate **22**.

[0074] **FIG. 9** illustrates a handheld system for sensing a target chemical species, in accordance with one embodiment of the present invention. Handheld system **70** includes an enclosure **60**, a self-sensed cantilevered probe array **20**, at least one chemical-sensitive coating material **34** applied to at least one self-sensed cantilevered probe **30** in cantilevered probe array **20**, and an interface circuit **40** coupled to cantilevered probe array **20**. Enclosure **60** has an inlet port **62** to allow ingress of target chemical species **12** into

enclosure **60** and an outlet port **64** to allow egression of target chemical species **12** or a by-product thereof from enclosure **60**. When cantilevered probe array **20** is exposed to target chemical species **12** and cantilevered probe array **20** is actuated by interface circuit **40**, one or more cantilevered probes **30** in cantilevered probe array **20** exhibit a shifted cantilevered probe response.

[0075] Cantilevered probe array **20** includes a plurality of cantilevered probes **30** that are frequency-differentiated. The plurality of cantilevered probes **30** in cantilevered probe array **20** is electrically connected to a pair of cantilevered probe array drive pads, and one or more groups of cantilevered probes **30** may be included within enclosure **60**.

[0076] Handheld system **70** may include a controller **50** in communication with interface circuit **40**. Controller **50** receives a shifted cantilevered probe response from a set of cantilevered probes **30** in cantilevered probe array **20**. The shifted cantilevered probe responses are analyzed and the constituency and concentration of target chemical species **12** may be determined based on the shifted cantilevered probe response.

[0077] Cantilevered probe array **20** may include a reference cantilevered probe **30r**. The reference cantilevered probe **30r** provides a reference cantilevered probe response when cantilevered probe array **20** is exposed to target chemical species **12**.

[0078] One or more cantilevered probes **30** in cantilevered probe array **20** may have resistive heaters **36** to locally heat selected cantilevered probes **30**. A species attraction electrode **38** may be disposed on one or more cantilevered probes **30** in cantilevered probe array **20** to allow application of a species attraction potential.

[0079] Handheld system **70** may include a transport mechanism **66** such as a pump, fan or blower and ductwork or piping for transporting target chemical species **12** to cantilevered probe array **20**. Handheld system **70** may include a concentrator **68** such as a compressor or a condenser to concentrate target chemical species **12** proximal to one or more cantilevered probes **30** in cantilevered probe array **20**.

[0080] Command and data entry input devices such as buttons, keypads, or softkeys, allow the selection of the function and operation of handheld system **70**. Results of measurements are displayed on an output device such as an LCD, or communicated to another analysis system through a wired communication port such as a universal serial bus (USB) port or through a wireless communication protocol.

[0081] **FIG. 10** is a flow chart of a method for chemical detection, in accordance with one embodiment of the present invention. The chemical detection method includes various steps to detect and identify one or more target chemical species with a self-sensed cantilevered probe array.

[0082] The cantilevered probes in the cantilevered probe array are frequency-differentiated, separated in the frequency domain such that any one of the cantilevered probes can be measured independently of the others using, for example, a frequency generator, a frequency synthesizer, a controlled oscillator, or an impedance analyzer when the cantilevered probes are configured in series or in parallel with other cantilevered probes. The cantilevered probe array

includes, for example, at least two-series connected cantilevered probes electrically connected to a pair of cantilevered probe array drive pads. Alternatively, the cantilevered probe array includes at least two parallel-connected cantilevered probes electrically connected to a pair of cantilevered probe array drive pads. Alternatively, the cantilevered probe array includes a network of series-connected and parallel-connected cantilevered probes electrically connected to a pair of cantilevered probe array drive pads. One or more groups of cantilevered probes may be connected to the same set of cantilevered probe array drive pads or to a different set of cantilevered probe array drive pads on the same substrate for external connection to an interface circuit.

[0083] After fabrication of the cantilevered probe array, a chemical-sensitive coating material may be applied to one or more cantilevered probes in the cantilevered probe array, as seen at block 100. The chemical-sensitive coating material may include, for example, an epoxy resin, a fluoropolymer, a gold layer, a palladium layer, an alcohol-absorbent polymer, a water-absorbent material, a chemical-sensitive polymer, a chemical-sensitive layer, a biosensitive material, a thiol, and combinations thereof.

[0084] The coating material may be applied, for example, by standard deposition techniques such as sputter depositions, electron beam depositions, or plasma-enhanced chemical vapor depositions, or by dipping, spraying or dispensing the coating material onto at least a portion of one or more cantilevered probes. The coating material may be applied, for example, with a stencil mask and selective masking of one or more cantilevered probes and applying the chemical-sensitive coating through the mask. A single material may be applied through the mask.

[0085] A plurality of chemical-sensitive coating materials may be applied to a set of cantilevered probes in the cantilevered probe array. For example, multiple masks may be used for multiple coatings with different coating materials on selected portions of one or more cantilevered probes. Alternatively, coating with multiple materials through a single mask may be accomplished by spraying a non-homogenous coating material onto a set of cantilevered probes in the cantilevered probe array such that cantilevered probes in the array are coated with substantive differences in coating constituency, thickness, or fraction of coverage.

[0086] When a resistive heater is used, the resistive heater that is coupled to at least one cantilevered probe is heated to initialize the cantilevered probe prior to exposing the cantilevered probe array to the target chemical species, as seen at block 102. The resistive heater locally heats up the cantilevered probe to an elevated temperature to evaporate, burn off, or otherwise remove residual materials from the surfaces of the cantilevered probe.

[0087] The array is initialized, as seen at block 104. Initialization of the array is accomplished, for example, by running a scan through the resonant frequencies of the cantilevered probes in the cantilevered probe array to establish a baseline or to ensure that all the cantilevered probes and the interface electronics are functioning properly.

[0088] The target chemical species may be transported to the cantilevered probe array, as seen at block 106. Fans, blowers, or pumps may be used, for example, to force flow of the target chemical species and a carrier gas or liquid onto

the cantilevered probe array. Convective processes or normal diffusive processes due to concentration gradients may be used, for example, to transport the target chemical species to the cantilevered probe array for detection.

[0089] The target chemical species may be concentrated proximal to the cantilevered probe array, as seen at block 108. Concentration of the target chemical species may be accomplished, for example, with a compressor and a valve system to increase the pressure in the vicinity of the cantilevered probe array. A condenser and a heater may be used, for example, to collect samples of the target chemical species and then release it in proximity to the cantilevered probe array.

[0090] Selective attraction of chemical and biological species may be accomplished with, for example, a species attraction potential applied to a species attraction electrode disposed on at least one cantilevered probe in the cantilevered probe array.

[0091] The self-sensed cantilevered probe array is exposed to a target chemical species, as seen at block 110. The target chemical species may be in a liquid or a gas. A valve and associated piping may be used to expose the cantilevered probe array to the target chemical species and the carrier.

[0092] When embodied so, the resistive heater coupled to at least one cantilevered probe may be heated to react the target chemical species, as seen at block 112. Reaction of the target chemical species may be result, for example, in a volatile material that is desorbed from one or more cantilevered probes resulting in a shift in the resonant frequency due to less mass on the beam. Alternatively, reaction of the target chemical species may result in a formation of a material on the surface of the cantilevered probe that increases the vibrational stiffness of the cantilevered probe and produces a frequency shift. Alternatively, reaction of the target chemical species may result in a stressed film on the surface of the cantilevered probe that causes a static deflection of the cantilevered probe, which may be measured, for example, with a tapping mode where the cantilevered beam is tapped against a reference surface adjusted to be a fixed distance away from the cantilevered beam or with a tapping mode where the beam is tapped against an adjustable mechanical stop, adjusted to allow the cantilevered probe to tap a consistent amount against the mechanical stop.

[0093] The exposed cantilevered probe array is actuated, as seen at block 114. The exposed cantilevered probes are actuated, for example, by applying an excitation voltage to a piezoelectric material disposed on each cantilevered probe in the cantilevered probe array. In another example, the exposed cantilevered probe array is actuated with a frequency generator by scanning the cantilevered probes through a predetermined frequency range. In another example, the exposed cantilevered probe array is actuated by driving the exposed array at a resonant frequency of one cantilevered probe in the cantilevered probe array, then switching as desired to a resonant frequency of another cantilevered probe for additional measurements. In another example, the exposed cantilevered probe array is actuated by driving the exposed array at a predetermined frequency, wherein the predetermined frequency is off-resonance with respect to at least one cantilevered probe in the cantilevered probe array. In another example, the amplitude of vibration

is controlled as the cantilevered probe strikes against a fixed or adjustable mechanical stop. In another example, the exposed cantilevered array is actuated with an electrical impulse applied to the cantilevered probe array.

[0094] A cantilevered probe response is detected from at least one self-sensed cantilevered probe in the cantilevered probe array, as seen at block 116. Detecting the cantilevered probe response from one or more actuated cantilevered probes comprises, for example, measuring a shifted resonant frequency, a shifted Q factor, a shifted impedance, a shifted deflection amplitude, and a combination thereof. A fast Fourier transform (FFT) may be performed on the cantilevered probe response from one or more actuated cantilevered probes. The entire array of cantilevered probes, a subset thereof, or an individual cantilevered probe may be addressed by selective actuation and detection.

[0095] With the availability of a reference cantilevered probe, a reference cantilevered probe response may be detected from one or more reference cantilevered probes in the cantilevered probe array.

[0096] The target chemical species is determined based on the detected cantilevered probe response, as seen at block 118. A controller or a software application running on a computer or digital device may be used to analyze the cantilevered probe responses and determine one or more components and their concentration in the sample. The target chemical species may be determined in part based on the detected reference cantilevered probe response, for example, by common mode correcting for effects such as temperature, pressure and viscosity of the sampled medium. The detected target chemical species may include, for example, mercury, hydrogen, an alcohol, water vapor, an explosive material, a chemical element, a chemical compound, an organic material, an inorganic material, a gaseous substance, a liquid, a biological material, a DNA strand, a bioactive agent, a toxin, and combinations thereof.

[0097] Using pattern recognition, modeling functions or signal processing techniques such as fuzzy logic, the target chemical species may be determined based on comparing a measured shift from one or more actuated cantilevered probes to a reference set of cantilevered probe response, and determining the target chemical species based on the reference set of cantilevered probe responses. The reference set of cantilevered probe responses may comprise, for example, a learned set from calibration runs or from a statistical database with expectation values for various target chemical species.

[0098] FIG. 11 is a flow chart of a method for chemical detection, in accordance with another embodiment of the present invention. The chemical detection method includes various steps to detect and identify one or more target chemical species with a self-sensed cantilevered probe array.

[0099] A self-sensed cantilevered probe array is provided, as seen at block 120. The cantilevered probes in the cantilevered probe array are frequency-differentiated, and may include at least two series-connected or parallel-connected cantilevered probes electrically connected to a pair of cantilevered probe array drive pads. Alternatively, the cantilevered probe array includes a network of series-connected and parallel-connected cantilevered probes electrically connected to a pair of cantilevered probe array drive pads.

[0100] The array is initialized, as seen at block 122. Initialization of the array is accomplished, for example, by running a scan through the resonant frequencies of the cantilevered probes in the cantilevered probe array to establish a baseline or to ensure that all the cantilevered probes and the interface electronics are functioning properly.

[0101] The self-sensed cantilevered probe array is exposed to a target chemical species, as seen at block 124. The target chemical species may be in a liquid or a gas. A valve and associated piping may be used to expose the cantilevered probe array to the target chemical species and the carrier.

[0102] The exposed cantilevered probe array is actuated, as seen at block 126. The exposed cantilevered probes are actuated, for example, by applying an excitation voltage to a piezoelectric material disposed on each cantilevered probe in the cantilevered probe array; by scanning the cantilevered probes through a predetermined frequency range; by driving the exposed array at a resonant frequency of at least one cantilevered probe in the cantilevered probe array; by driving the exposed array at a predetermined off-resonance frequency; by driving and controlling the tapping of the cantilevered probes against a fixed or adjustable mechanical stop; or by applying an electrical impulse to the cantilevered probe array.

[0103] A cantilevered probe response is detected from at least one self-sensed cantilevered probe in the cantilevered probe array and the target chemical species is determined, as seen at block 128. Detecting the cantilevered probe response from one or more actuated cantilevered probes comprises, for example, measuring a shifted resonant frequency, a shifted Q factor, a shifted impedance, a shifted deflection amplitude, and a combination thereof. A fast Fourier transform (FFT) may be performed on the cantilevered probe response from one or more actuated cantilevered probes to detect the target chemical species. The target chemical species is determined based on the detected cantilevered probe response. The target chemical species may be determined based on comparing a measured shift from one or more actuated cantilevered probes to a reference set of cantilevered probe responses, and determining the target chemical species based on the reference set of cantilevered probe responses.

[0104] While the embodiments of the invention disclosed herein are presently considered to be preferred, various changes and modifications can be made without departing from the spirit and scope of the invention. The detailed description and drawings are merely illustrative of the invention rather than limiting, the scope of the invention being defined by the appended claims and equivalents thereof, and all variations and embodiments that come within the meaning and range of equivalents are embraced herein.

1-32. (canceled)

33. The method of claim 69 wherein at least a portion of the cantilevered probes in the cantilevered probe array is frequency-differentiated.

34. The method of claim 69 wherein the target chemical species detected is mercury, hydrogen, an alcohol, water vapor, an explosive material, a chemical element, a chemical compound, an organic material, an inorganic material, a

gaseous substance, a liquid, a biological material, a DNA strand, a bioactive agent, a toxin, or combinations thereof.

35. The method of claim 69 wherein exposing a self-sensed cantilevered probe array to a target chemical species comprises exposing the cantilevered probe array to a liquid or a gas.

36. The method of claim 69, further comprising actuating the exposed cantilevered probe array by applying an excitation voltage to a piezoelectric material disposed on each cantilevered probe in the cantilevered probe array.

37. The method of claim 69 wherein the cantilevered probe array comprises at least two series-connected cantilevered probes electrically connected to a pair of cantilevered probe array drive pads.

38. The method of claim 69 wherein the cantilevered probe array comprises at least two parallel-connected cantilevered probes electrically connected to a pair of cantilevered probe array drive pads.

39. The method of claim 69 wherein the cantilevered probe array comprises a network of series-connected and parallel-connected cantilevered probes electrically connected to a pair of cantilevered probe array drive pads.

40. The method of claim 69, further comprising actuating the exposed cantilevered probe array by scanning the cantilevered probes through a predetermined frequency range.

41. The method of claim 69, further comprising actuating the exposed cantilevered probe array by driving the exposed array at a resonant frequency of the at least one cantilevered probe in the cantilevered probe array.

42. The method of claim 69, further comprising actuating the exposed cantilevered probe array by driving the exposed array at a predetermined frequency, wherein the predetermined frequency is off-resonance with respect to at least one cantilevered probe in the cantilevered probe array.

43. The method of claim 69 further comprising actuating the exposed cantilevered probe array by applying an electrical impulse to the cantilevered probe array.

44. The method of claim 69 wherein detecting the cantilevered probe response from the at least one actuated cantilevered probe comprises measuring one of a shifted resonant frequency, a shifted Q factor, a shifted impedance, and a shifted deflection amplitude.

45. The method of claim 69 wherein detecting the cantilevered probe response from the at least one actuated cantilevered probe comprises performing a fast Fourier transform on the cantilevered probe response.

46. The method of claim 69 wherein determining the target chemical species based on the cantilevered probe response comprises comparing a measured shift from the at least one actuated cantilevered probe to a reference set of cantilevered probe responses, and determining the target chemical species based on the reference set of cantilevered probe responses.

47. The method of claim 46 wherein the reference set of cantilevered probe responses comprises a learned set.

48. The method of claim 69 further comprising:

detecting a reference cantilevered probe response from at least one reference cantilevered probe in the cantilevered probe array; and

determining the target chemical species based on a reference cantilevered probe response.

49. The method of claim 69 further comprising applying a chemical-sensitive coating material to the at least one cantilevered probe in the cantilevered probe array.

50. The method of claim 49 wherein the chemical-sensitive coating material is an epoxy resin, a fluoropolymer, a gold layer, a palladium layer, an alcohol-absorbent polymer, a water-absorbent material, a chemical-sensitive polymer, a chemical-sensitive layer, a biosensitive material, a thiol, or combinations thereof.

51. The method of claim 49 wherein applying the coating material comprises one of dipping, spraying, or dispensing a coating material onto a portion of the at least one cantilevered probe.

52. The method of claim 49 wherein applying the coating material comprises masking the at least one cantilevered probe and applying the chemical-sensitive coating through the mask.

53. The method of claim 69 wherein applying the coating material comprises spraying a non-homogeneous coating material onto a set of cantilevered probes in the cantilevered probe array.

54. The method of claim 69 further comprising applying a plurality of chemical-sensitive coating materials to a set of cantilevered probes in the cantilevered probe array.

55. The method of claim 69 further comprising heating the resistive heater coupled to the at least one cantilevered probe to initialize the cantilevered probe prior to exposing the cantilevered probe array to the target chemical species.

56. The method of claim 69 further comprising heating the resistive heater coupled to the at least one cantilevered probe to react the target chemical species.

57. The method of claim 69 further comprising applying a species attraction potential to a species attraction electrode disposed on the at least one cantilevered probe in the cantilevered probe array.

58. The method of claim 69 further comprising transporting the target chemical species to the cantilevered probe array.

59. The method of claim 69 further comprising concentrating the target chemical species proximal to the cantilevered probe array.

60-68. (canceled)

69. A method of chemical detection, comprising:

exposing a self-sensed cantilevered probe array to a target chemical species, thereby providing an exposed cantilevered probe array; heating a resistive heater coupled to at least one cantilevered probe to analyze the target chemical species;

actuating the exposed cantilevered probe array;

detecting a cantilevered probe response from the at least one self-sensed cantilevered probe in the cantilevered probe array; and

determining the target chemical species based on the cantilevered probe response.

70. The method of claim 69 further comprising heating the resistive heater coupled to the at least one cantilevered probe to initialize the cantilevered probe prior to exposing the cantilevered probe array to the target chemical species.

71-80. (canceled)

81. The method of claim 69 wherein at least one of the plurality of cantilevered probes is at least partially made from one or more materials comprising a polymeric layer.

82. The method of claim 69, wherein at least one of the plurality of cantilevered probes is at least partially made from one or more materials comprising a piezoelectric material.

83-84. (canceled)

85. The method of claim 69, wherein at least one of the plurality of cantilevered probes is at least partially made from one or more materials comprising a piezoelectric material, silicon, polysilicon, silicon nitride, a metal, a metal alloy, a metal sheet, a metal film, a ceramic material, an ionic compound, a zinc oxide film, a PZT film, a polymeric layer, or combinations thereof.

86. The method of claim 69, wherein the chemical-sensitive coating material comprises an epoxy resin, a fluoropolymer, a gold layer, a palladium layer, an alcohol-absorbent polymer, a water-absorbent material, a chemical-sensitive polymer, a chemical-sensitive layer, a biosensitive material, a thiol, or combinations thereof.

87. The method of claim 82, wherein the chemical-sensitive coating material comprises an epoxy resin, a fluoropolymer, a gold layer, a palladium layer, an alcohol-absorbent polymer, a water-absorbent material, a chemical-sensitive polymer, a chemical-sensitive layer, a biosensitive material, a thiol, or combinations thereof.

88-96. (canceled)

97. A cantilevered probe array system for detecting at least one target chemical species, comprising:

a cantilevered probe array comprising a plurality of cantilevered probes, each of the plurality of cantilevered probes comprising:

a piezoelectric layer;

a first electrode in electrical communication with the piezoelectric layer;

a second electrode in electrical communication with the piezoelectric layer;

a resistive heater;

a first electrical lead; and

a second electrical lead;

wherein the first and second leads are in electrical communication with the piezoelectric layer of each of the plurality of cantilevered probes.

98. The cantilevered probe array system of claim 97, further comprising a circuit coupled to the cantilevered probe array, including the piezoelectric layers of at least a portion of the plurality of cantilevered probes, the circuit comprising an excitation voltage generator in electrical communication with the piezoelectric layers of each of the cantilevered probes of the at least a portion of the plurality of cantilevered probes, and a signal detector in electrical communication with the piezoelectric layers of each of the cantilevered probes of the at least a portion of the plurality of cantilevered probes; wherein at least one cantilevered probe in the cantilevered probe array exhibits a shifted signal that is detected by the signal detector when the cantilevered probe array is exposed to the target chemical species and the at least one cantilevered probe is moved by the circuit.

99. The cantilevered probe array system of claim 98 wherein the excitation voltage generator comprises an oscillator circuit operating at a predetermined frequency, wherein

the predetermined frequency is off-resonance with respect to at least one cantilevered probe in the cantilevered probe array.

100. The cantilevered probe array system of claim 98 wherein the excitation voltage generator comprises an impulse circuit for applying an electrical impulse to the cantilevered probe array.

101. The cantilevered probe array system of claim 98 wherein the signal detector includes a fast Fourier transform generator to perform a fast Fourier transform on the shifted signal.

102. The cantilevered probe array system of claim 98 wherein the circuit detects a shifted signal from at least one actuated cantilevered probe.

103. The cantilevered probe array system of claim 102 wherein the shifted signal comprises one of a shifted resonant frequency, a shifted Q factor, a shifted impedance, and a shifted deflection amplitude.

104. The cantilevered probe array system of claim 98 further comprising a controller in communication with the circuit; wherein the controller receives a shifted signal from a set of cantilevered probes in the cantilevered probe array, and wherein the target chemical species is determined based on the shifted signal.

105. The cantilevered probe array system of claim 104, wherein the controller comprises an analyzer.

106. The cantilevered probe array system of claim 98 further comprising a controller in communication with the circuit; wherein the controller receives a shifted signal from a set of cantilevered probes in the cantilevered probe array, and wherein the target chemical species is determined based on a comparison between the shifted signal and a reference set of cantilevered probe signals.

107. The cantilevered probe array system of claim 106 wherein the reference set of cantilevered probe signals comprises a learned set.

108. The cantilevered probe array system of claim 98 wherein the target chemical species detected is mercury, hydrogen, an alcohol, water vapor, an explosive material, a chemical element, a chemical compound, an organic material, an inorganic material, a gaseous substance, a liquid, a biological material, a DNA strand, a bioactive agent, a toxin, or combinations thereof.

109. The cantilevered probe array system of claim 98, wherein the circuit detects cantilever bending.

110. The cantilevered probe array system of claim 98 wherein the excitation voltage generator comprises an adjustable frequency generator that is scanned through a predetermined frequency range.

111. The cantilevered probe array system of claim 98 wherein the signal detector comprises an impedance analyzer that is scanned through a resonant frequency of at least one cantilevered probe in the cantilevered probe array.

112. The cantilevered probe array system of claim 98 wherein the excitation voltage generator comprises an oscillator circuit operating at a resonant frequency of at least one cantilevered probe in the cantilevered probe array.

113. The cantilevered probe array system of claim 97, at least one cantilevered probe of the plurality of cantilevered probes comprising at least one chemical sensitive coating material applied to the at least one cantilevered probe.

114. The cantilevered probe array system of claim 113, wherein the at least one chemical sensitive coating material is a first chemical sensitive coating material applied to a first

cantilevered probe and a second chemical sensitive coating material applied to a second cantilevered probe in the cantilevered probe array.

115. The cantilevered probe array system of claim 114, wherein the first and second chemical sensitive coating materials are different.

116. The cantilevered probe array system of claim 114, wherein the resistive heaters formed on the first and second cantilevered probes are individually controllable.

117. The cantilevered probe array system of claim 113, wherein the chemical-sensitive coating material comprises an epoxy resin, a fluoropolymer, a gold layer, a palladium layer, an alcohol-absorbent polymer, a water-absorbent material, a chemical-sensitive polymer, a chemical-sensitive layer, a biosensitive material, a thiol, or combinations thereof.

118. The cantilevered probe array system of claim 113 wherein the chemical-sensitive coating material is applied to at least a portion of the at least one cantilevered probe.

119. The cantilevered probe array system of claim 113 wherein the chemical-sensitive coating material is an epoxy resin, a fluoropolymer, a gold layer, a palladium layer, an alcohol-absorbent polymer, a water-absorbent material, a chemical-sensitive polymer, a chemical-sensitive layer, a biosensitive material, a thiol, or combinations thereof.

120. The cantilevered probe array system of claim 113 wherein the chemical-sensitive coating material comprises one of a dipped coating, a sprayed coating, or a dispensed coating disposed on at least a portion of the at least one cantilevered probe.

121. The cantilevered probe array system of claim 113 wherein the chemical-sensitive coating material comprises a masked coating disposed on a portion of the at least one cantilevered probe.

122. The cantilevered probe array system of claim 113 wherein the chemical-sensitive coating material comprises a non-homogeneous coating material applied to a set of cantilevered probes in the cantilevered probe array.

123. The cantilevered probe array system of claim 97 wherein at least a portion of the plurality of cantilevered probes in the cantilevered probe array is frequency-differentiated.

124. The cantilevered probe array system of claim 97 wherein at least one of the plurality of cantilevered probes is at least partially made from one or more materials comprising a piezoelectric material, silicon, polysilicon, silicon nitride, a metal, a metal alloy, a metal film, a metal sheet, a ceramic material, an ionic compound, a zinc oxide film, a PZT film, a polymeric layer, or combinations thereof.

125. The cantilevered probe array system of claim 97 wherein the cantilevered probe array is actuated with an excitation voltage applied across the piezoelectric layer of each of the plurality of cantilevered probes.

126. The cantilevered probe array system of claim 97 further comprising a cantilevered probe connected in series with the cantilevered probe array.

127. The cantilevered probe array system of claim 97 further comprising a cantilevered probe connected in parallel with the cantilevered probe array.

128. The cantilevered probe array system of claim 97 further comprising a cantilevered probe connected in series with the cantilevered probe array and a cantilevered probe connected in parallel with the cantilevered probe array.

129. The cantilevered probe array system of claim 97 further comprising a reference cantilevered probe in the cantilevered probe array, wherein the reference cantilevered probe provides a reference signal when the cantilevered probe array is exposed to the target chemical species.

130. The cantilevered probe array system of claim 97 further comprising a species attraction electrode disposed on at least one cantilevered probe in the cantilevered probe array to allow application of a species attraction potential.

131. The cantilevered probe array system of claim 97 further comprising an enclosure including the cantilevered probe array, an inlet port, and an outlet port; wherein the target chemical species enters through the inlet port, is exposed to the cantilevered probe array, and exits through the outlet port.

132. The cantilevered probe array system of claim 97 further comprising a transport mechanism for transporting the target chemical species to the cantilevered probe array.

133. The cantilevered probe array system of claim 97 further comprising a concentrator to concentrate the target chemical species proximal to the cantilevered probe array.

134. The cantilevered probe array system of claim 97, wherein the resistive heaters are individually controllable.

135. The cantilevered probe array system of claim 97, wherein the first and second electrodes are adjacent the piezoelectric layer.

136. The cantilevered probe array system of claim 97, wherein the first electrode is located on a first side of the piezoelectric layer and the second electrode is located on a second side of the piezoelectric layer.

137. The cantilevered probe array system of claim 136, wherein the first and second sides are opposite one another.

138. The cantilevered probe array system of claim 97, wherein at least one of the plurality of cantilevered probes is at least partially made from one or more materials comprising a metal, a metal alloy, or combinations thereof.

139. The cantilevered probe array system of claim 97, wherein at least one of the plurality of cantilevered probes is at least partially made from one or more materials comprising silicon, polysilicon, silicon nitride, or combinations thereof.

140. The cantilevered probe array system of claim 97, wherein at least one of the plurality of cantilevered probes is at least partially made from one or more materials comprising a polymeric layer.

141. The cantilevered probe array system of claim 97, wherein at least one of the plurality of cantilevered probes is at least partially made from one or more materials comprising a piezoelectric material.

142. The cantilevered probe array system of claim 97, wherein at least one of the plurality of cantilevered probes is at least partially made from one or more materials comprising PZT.

143. The cantilevered probe array system of claim 97, wherein at least one of the plurality of cantilevered probes is at least partially made from one or more materials comprising zinc oxide.

144. The cantilevered probe array system of claim 97, wherein at least one of the plurality of cantilevered probes is at least partially made from one or more materials comprising zinc oxide and the chemical-sensitive coating material comprises an epoxy resin, a fluoropolymer, a gold layer, a palladium layer, an alcohol-absorbent polymer, a

water-absorbent material, a chemical-sensitive polymer, a chemical-sensitive layer, a biosensitive material, a thiol, or combinations thereof.

145. A system for sensing a chemical species, comprising:

an enclosure, the enclosure having an inlet port to allow ingress of a chemical species into the enclosure and an outlet port to allow egress of the chemical species out from the enclosure;

a cantilevered probe array coupled to the enclosure, the cantilevered probe array comprising a plurality of cantilevered probes, each of the plurality of cantilevered probes comprising:

a piezoelectric layer;

a first electrode in electrical communication with the piezoelectric layer;

a second electrode in electrical communication with the piezoelectric layer;

a resistive heater;

a first electrical lead;

a second electrical lead, wherein the first and second leads are in electrical communication with the piezoelectric layer of each of the plurality of cantilevered probes; and

a circuit coupled to the cantilevered probe array.

146. The system of claim 145 wherein at least a portion of the plurality of cantilevered probes in the cantilevered probe array is frequency-differentiated.

147. The system of claim 145 wherein the plurality of cantilevered probes in the cantilevered probe array is electrically connected to a pair of cantilevered probe array drive pads.

148. The system of claim 145 further comprising a controller in communication with the circuit; wherein the controller receives a shifted signal from a set of cantilevered probes in the cantilevered probe array, and wherein the chemical species is determined based on the shifted signal.

149. The system of claim 145 further comprising a reference cantilevered probe in the cantilevered probe array, wherein the reference cantilevered probe provides a reference signal when the cantilevered probe array is exposed to the chemical species.

150. The system of claim 145 further comprising a species attraction electrode disposed on at least one cantilevered probe in the cantilevered probe array to allow application of a species attraction potential.

151. The system of claim 145 further comprising a transport mechanism for transporting the chemical species to the cantilevered probe array.

152. The system of claim 145 further comprising a concentrator for concentrating the chemical species proximal to the cantilevered probe array.

153. The system of claim 145, wherein the circuit is coupled to the piezoelectric layer of at least a portion of the plurality of cantilevered probes and the circuit comprises an excitation voltage generator in electrical communication with the piezoelectric layer of each of the cantilevered probes of the at least a portion of the plurality of cantilevered probes, and a signal detector in electrical communication with the piezoelectric layer of each of the cantilevered probes of the at least a portion of the plurality of cantilevered probes; wherein at least one cantilevered probe in the cantilevered probe array exhibits a shifted signal that is detected by the signal detector when the cantilevered probe array is exposed to the chemical species and the at least one cantilevered probe is moved by the circuit.

154. The system of claim 145, wherein the first and second electrodes are adjacent the piezoelectric layer.

155. The system of claim 145, wherein the first electrode is located on a first side of the piezoelectric layer and the second electrode is located on a second side of the piezoelectric layer.

156. The system of claim 155, wherein the first and second sides are opposite one another.

157. The method of claim 49, wherein applying the coating material comprises patterning the coating material photolithographically.

158. The method of claim 69, further comprising, prior to exposing a self-sensed cantilevered probe array to a target chemical species, scanning through resonant frequencies of the cantilevered probes array to establish a baseline.

* * * * *