



(19) **United States**

(12) **Patent Application Publication**
Baraniuk et al.

(10) **Pub. No.: US 2006/0239336 A1**

(43) **Pub. Date: Oct. 26, 2006**

(54) **METHOD AND APPARATUS FOR
COMPRESSIVE IMAGING DEVICE**

60/729,983, filed on Oct. 25, 2005. Provisional application No. 60/732,374, filed on Nov. 1, 2005. Provisional application No. 60/735,616, filed on Nov. 10, 2005. Provisional application No. 60/759,394, filed on Jan. 16, 2006.

(76) Inventors: **Richard G. Baraniuk**, Houston, TX (US); **Dror Z. Baron**, Houston, TX (US); **Marco F. Duarte**, Houston, TX (US); **Ilan N. Goodman**, Houston, TX (US); **Don H. Johnson**, Houston, TX (US); **Kevin F. Kelly**, Houston, TX (US); **Courtney C. Lane**, Ventura, CA (US); **Jason N. Laska**, Houston, TX (US); **Dharmpal Takhar**, Houston, TX (US); **Michael B. Wakin**, Houston, TX (US)

Publication Classification

(51) **Int. Cl.**
H04L 27/00 (2006.01)
(52) **U.S. Cl.** **375/216**

(57) **ABSTRACT**

A new digital image/video camera that directly acquires random projections of the incident light field without first collecting the pixels/voxels. In one preferred embodiment, the camera employs a digital micromirror array to perform optical calculations of linear projections of an image onto pseudorandom binary patterns. Its hallmarks include the ability to obtain an image with only a single detection element while measuring the image/video fewer times than the number of pixels or voxels—this can significantly reduce the computation required for image/video acquisition/encoding. Since the system features a single photon detector, it can also be adapted to image at wavelengths that are currently impossible with conventional CCD and CMOS imagers.

Correspondence Address:
24IP LAW GROUP USA, PLLC
12 E. LAKE DRIVE
ANNAPOLIS, MD 21403 (US)

(21) Appl. No.: **11/379,688**

(22) Filed: **Apr. 21, 2006**

Related U.S. Application Data

(60) Provisional application No. 60/673,364, filed on Apr. 21, 2005. Provisional application No. 60/679,237, filed on May 10, 2005. Provisional application No.

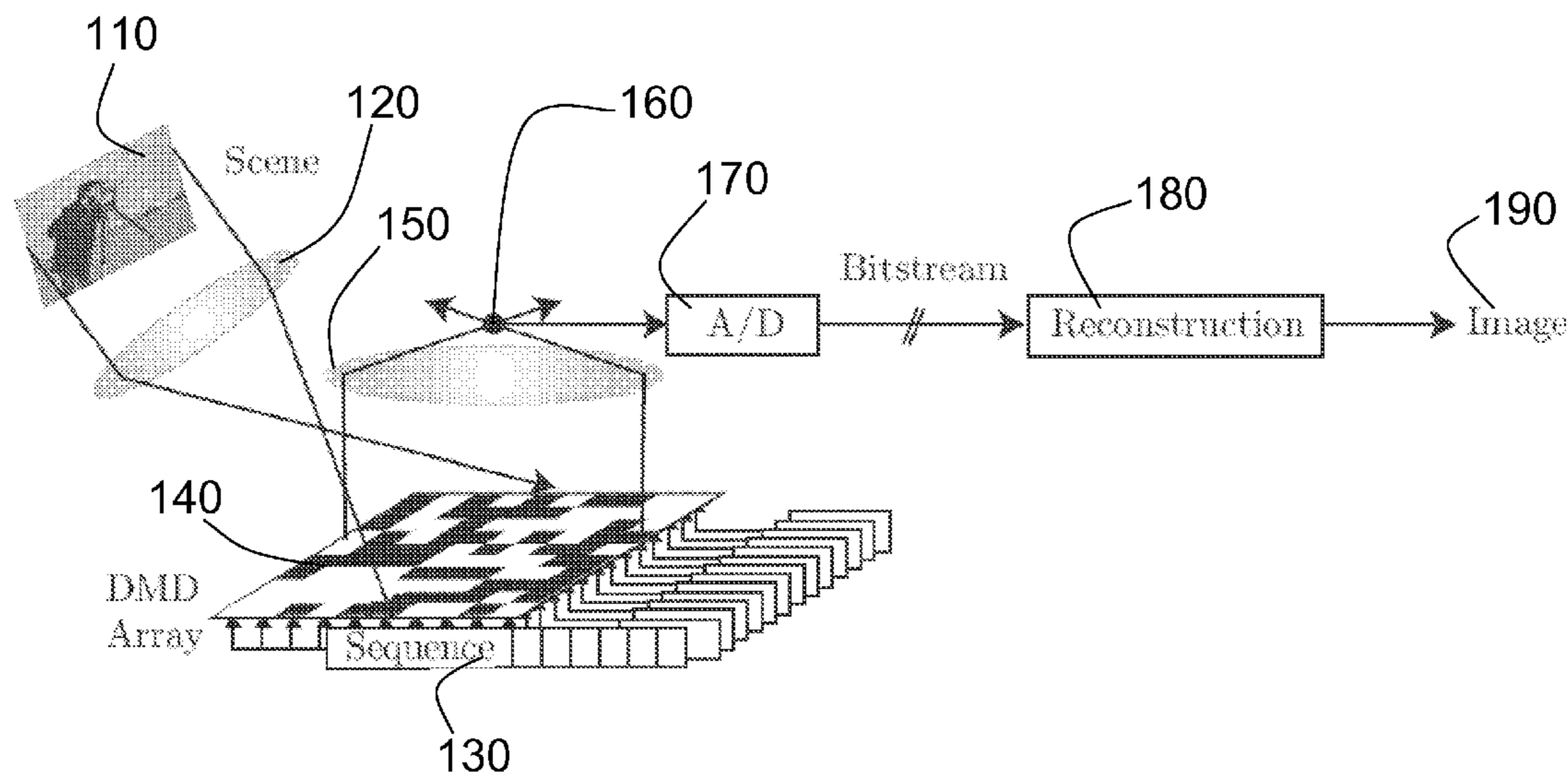

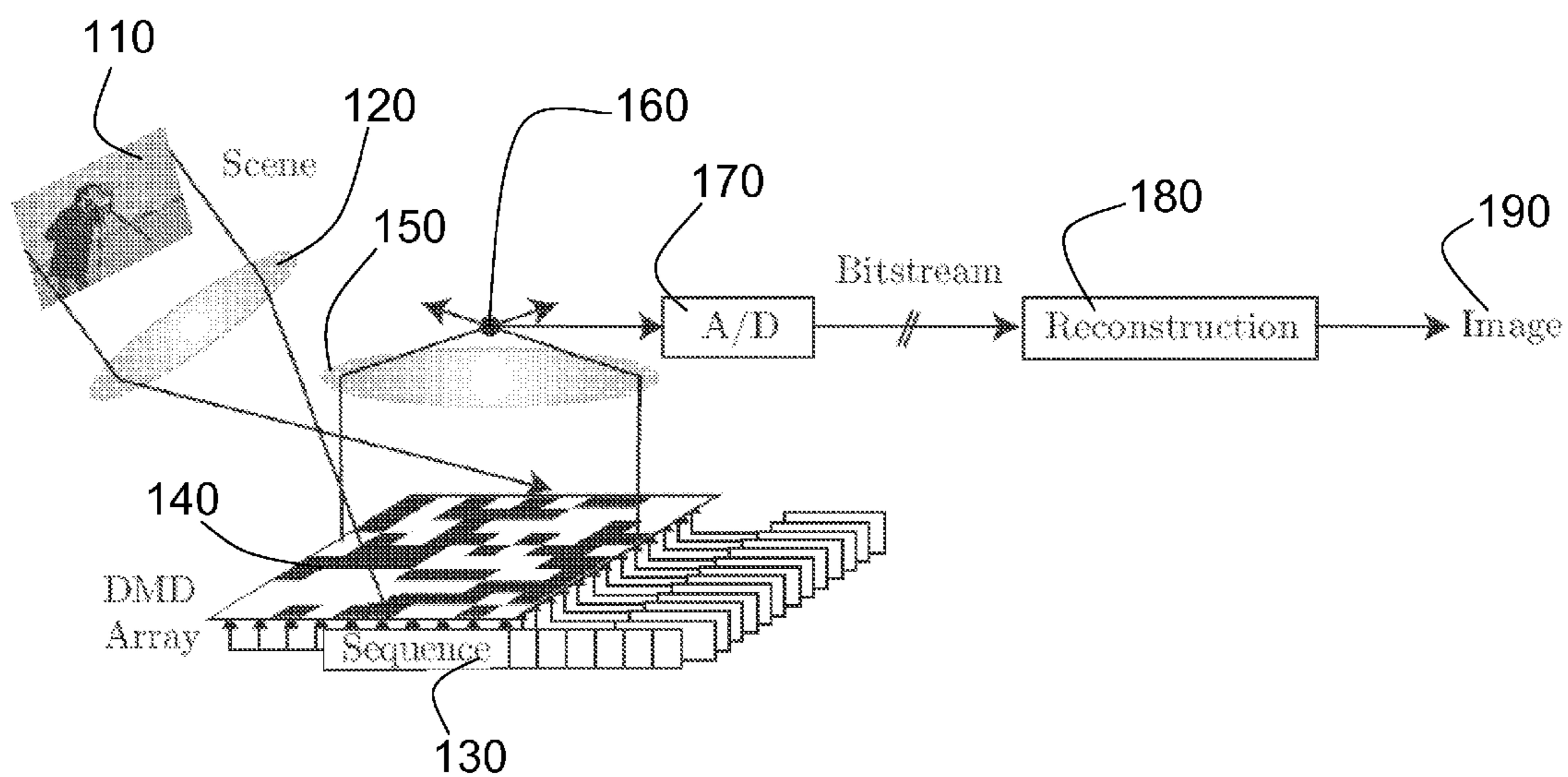

FIG. 1

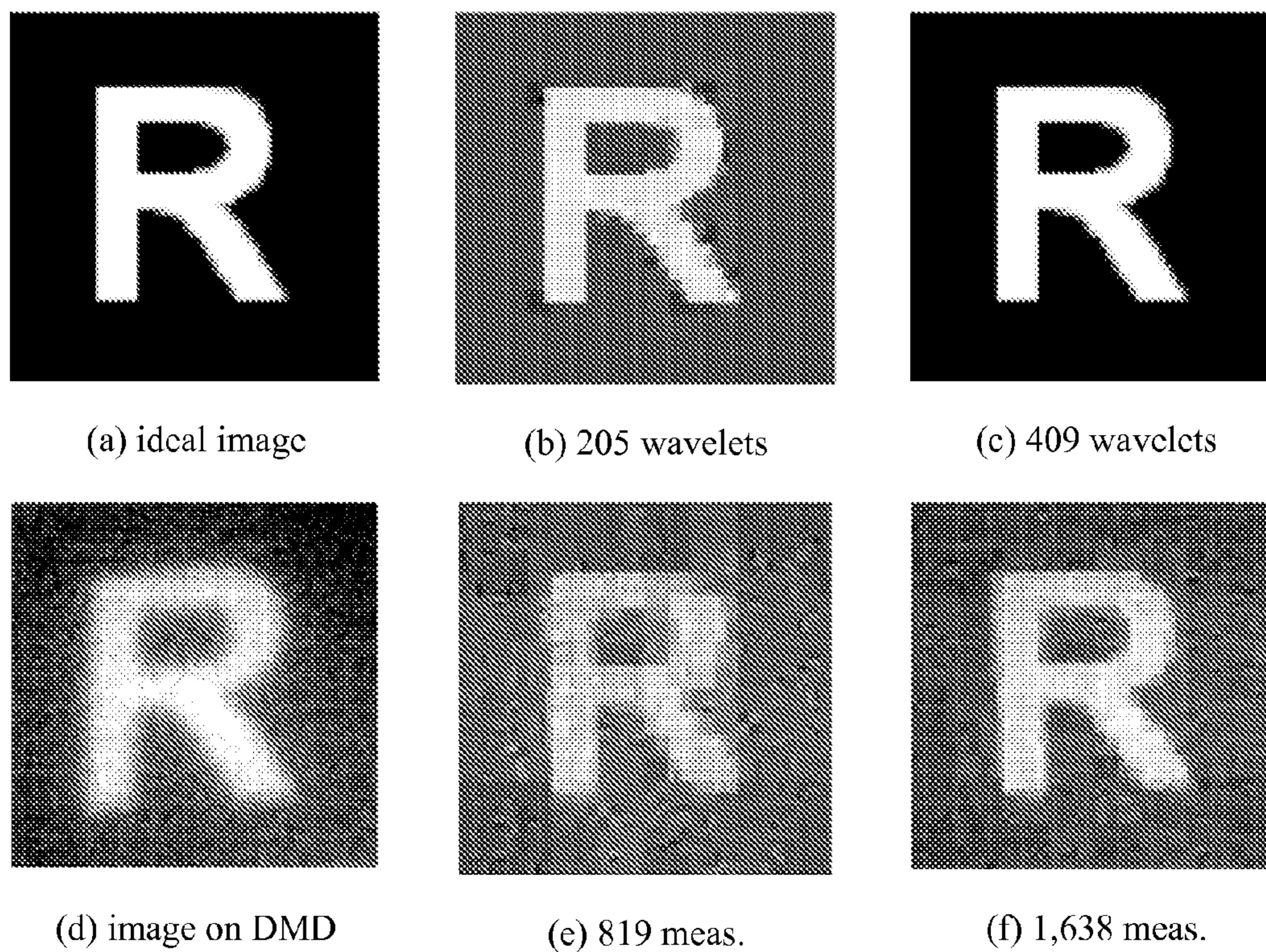

FIG. 2

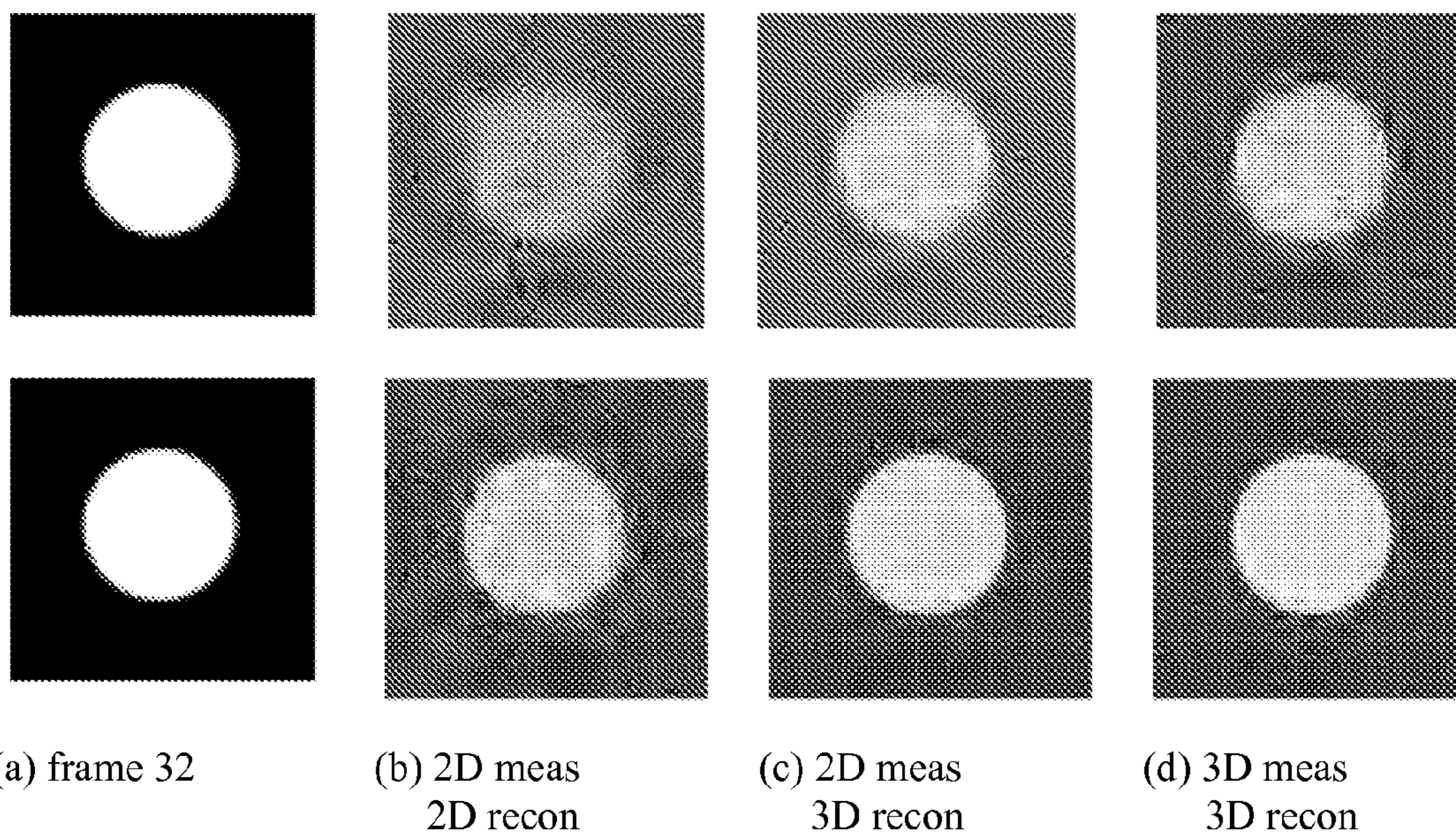

FIG. 3

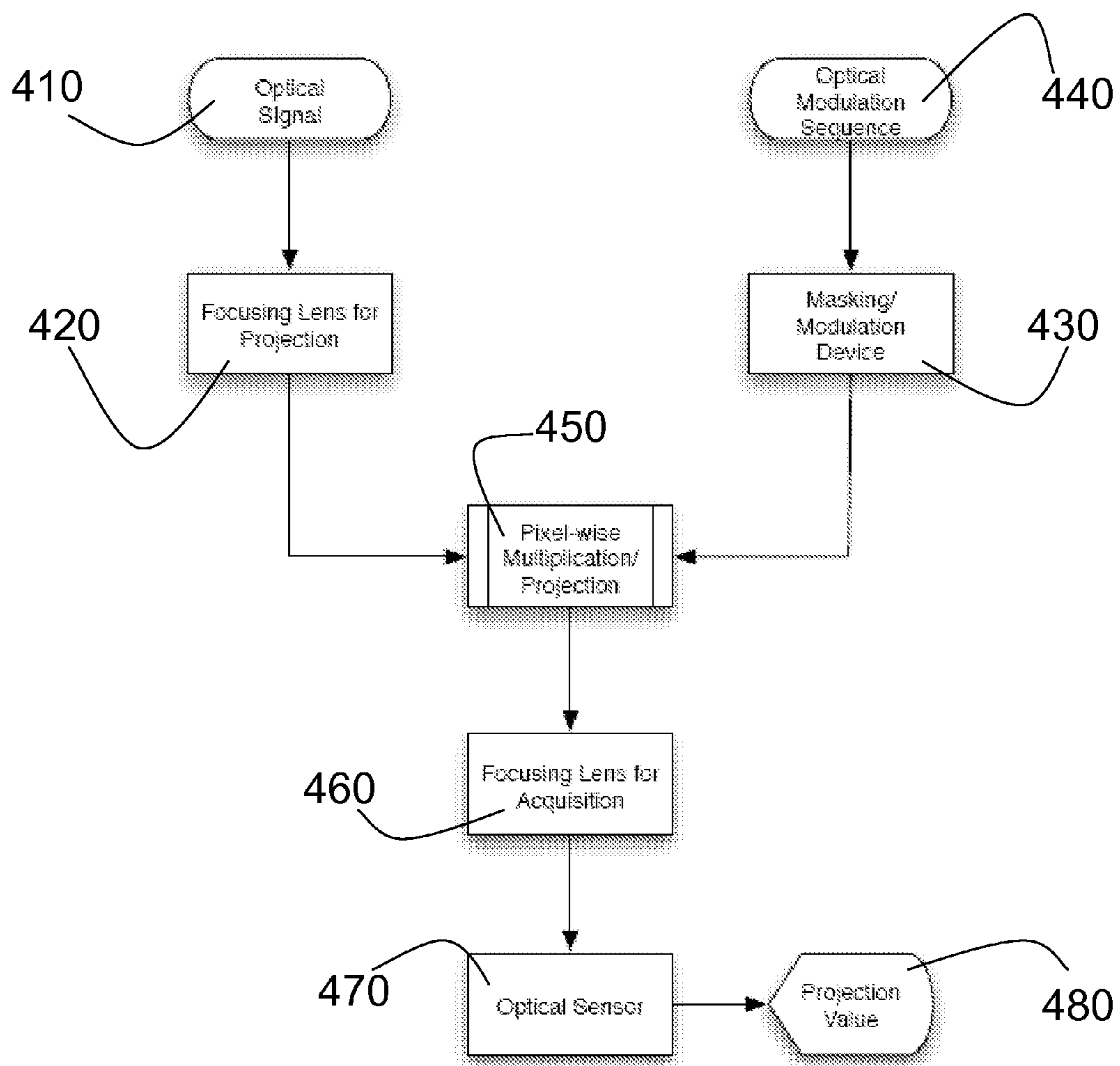

FIG. 4

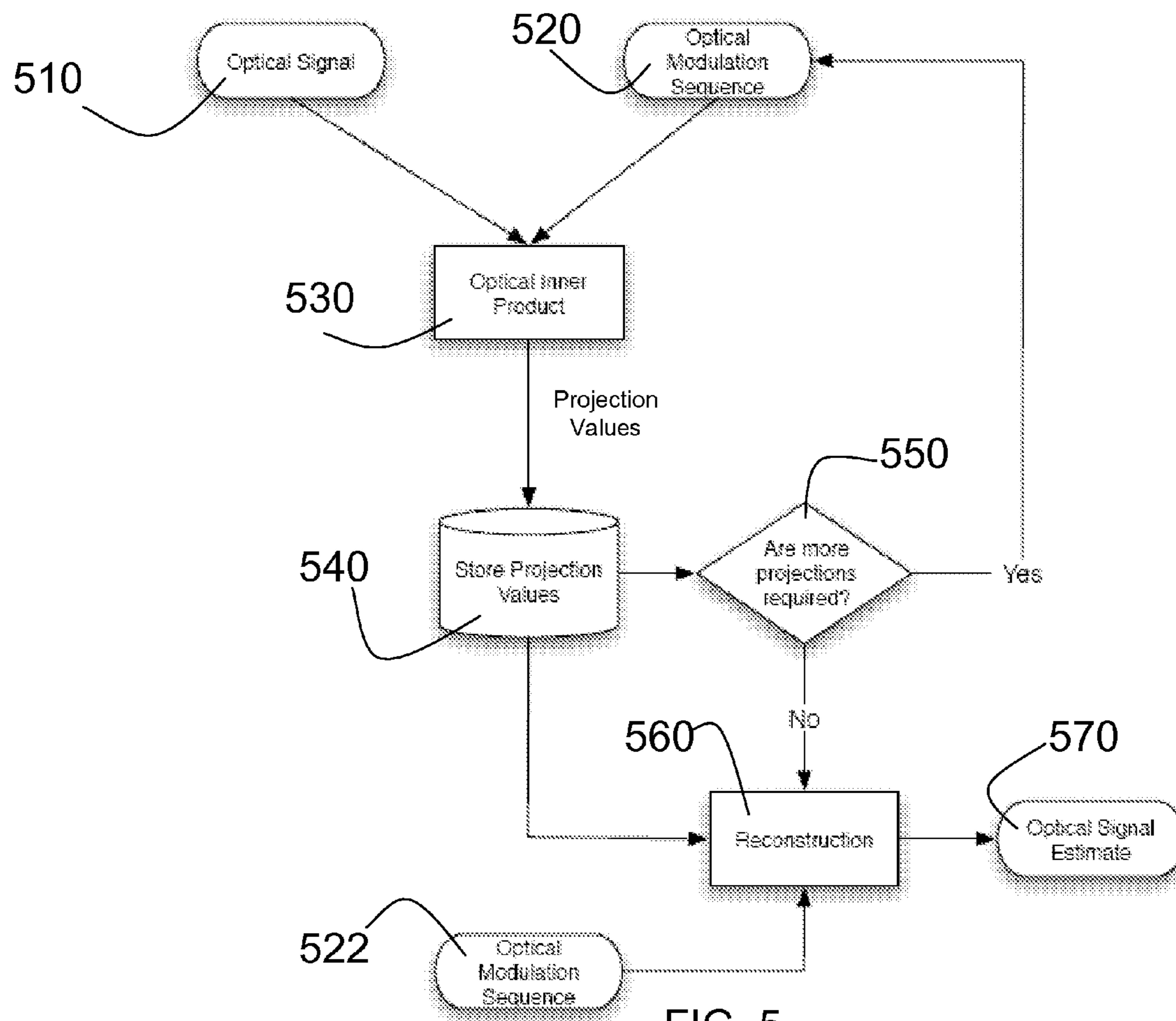

FIG. 5

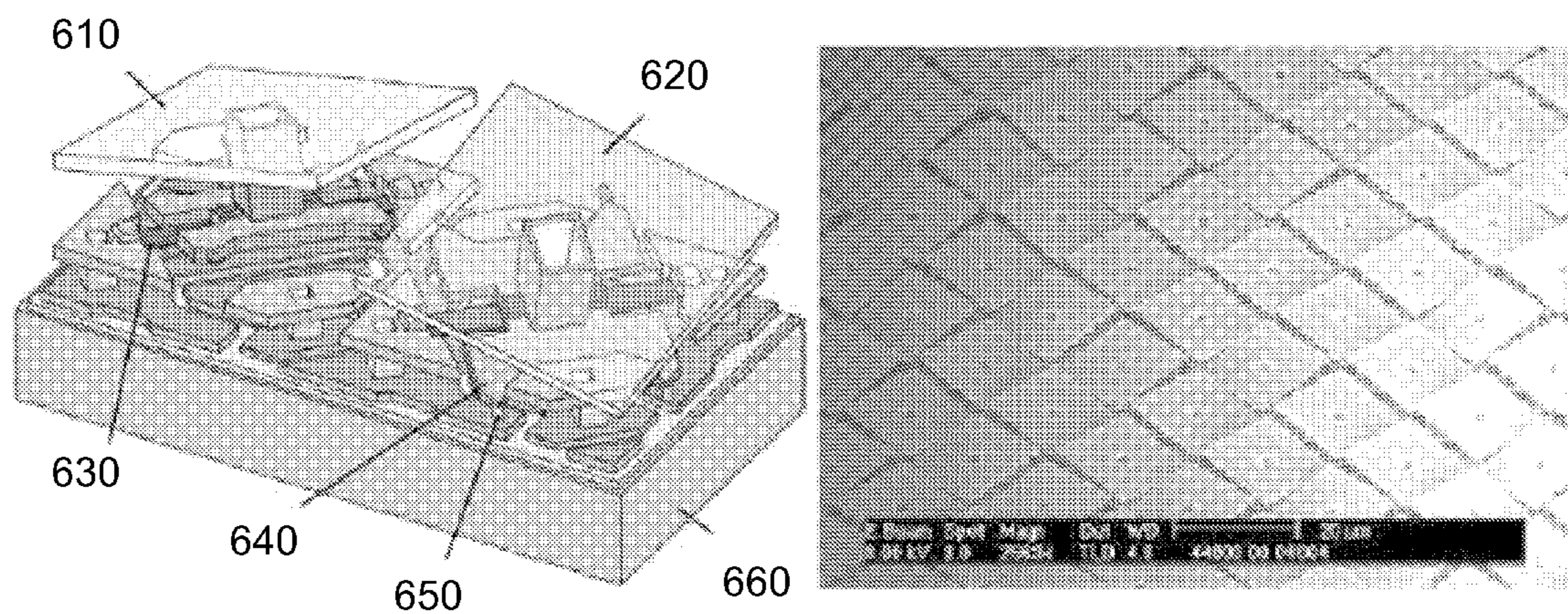
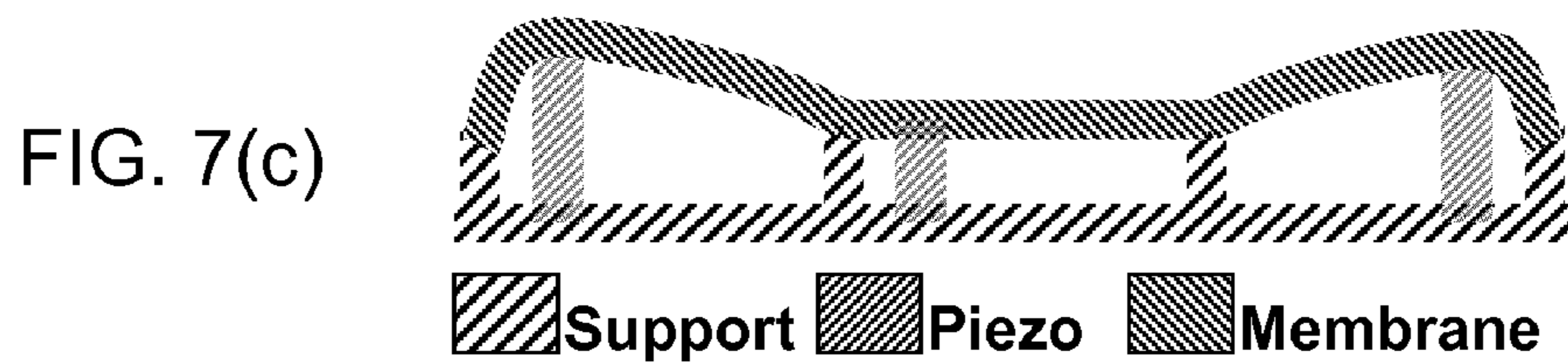
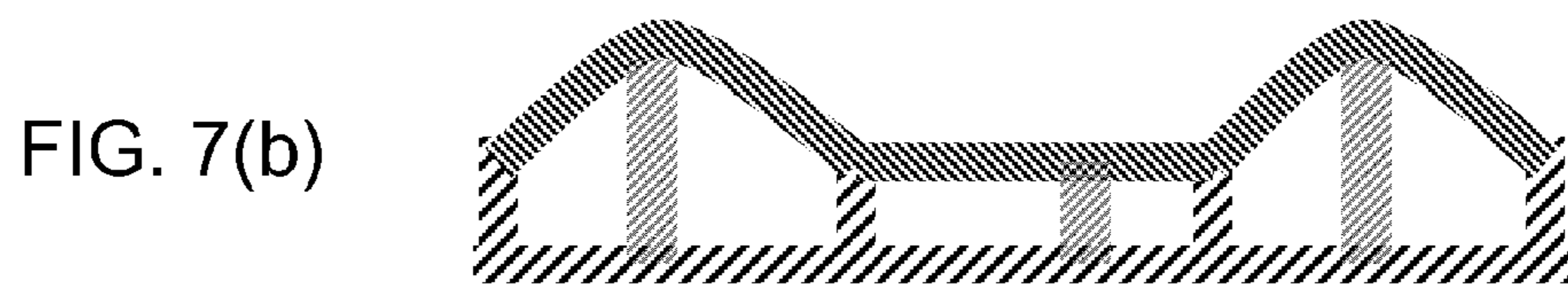
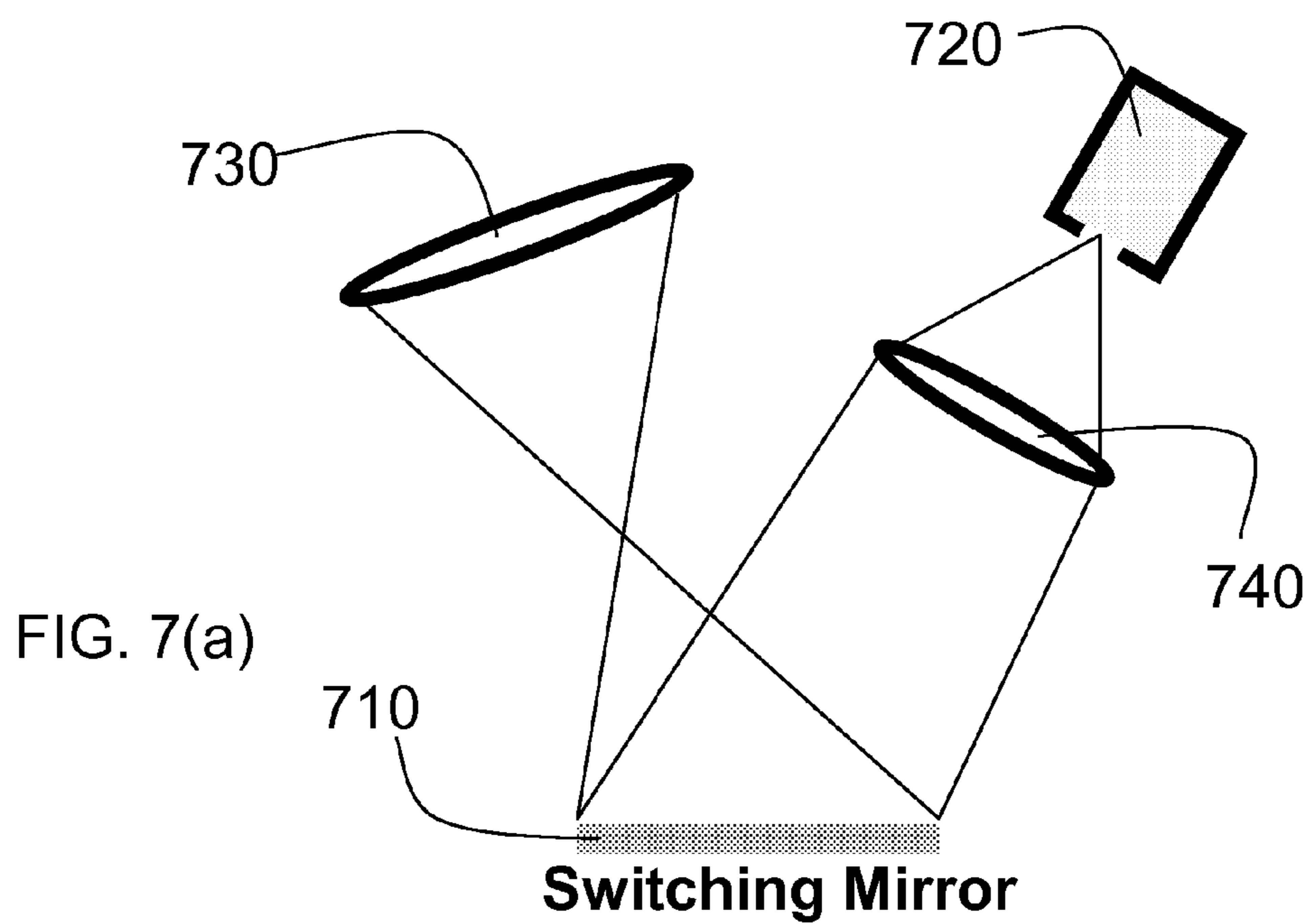

FIG. 6



METHOD AND APPARATUS FOR COMPRESSIVE IMAGING DEVICE

CROSS-REFERENCE TO RELATED APPLICATIONS

[0001] The present application claims the benefit of the filing dates of U.S. Provisional Application Ser. No. 60/673,364 entitled “Method and Apparatus for Optical Image Compression,” and filed on Apr. 21, 2005; U.S. Provisional Application Ser. No. 60/679,237 entitled “Method and Apparatus for Reconstructing Data from Multiple Sources,” and filed on May 10, 2005; U.S. Provisional Application Ser. No. 60/729,983 entitled “Random Filters for Compressive Sampling and Reconstruction,” and filed on Oct. 25, 2005; U.S. Provisional Application Ser. No. 60/732,374 entitled “Method and Apparatus for Compressive Sensing for Analog-to-Information Conversion,” and filed on Nov. 1, 2005; U.S. Provisional Application Ser. No. 60/735,616 entitled “Method and Apparatus for Distributed Compressed Sensing,” and filed on Nov. 10, 2005; and U.S. Provisional Application Ser. No. 60/759,394 entitled “Sudocodes: Efficient Compressive Sampling Algorithms for Sparse Signals,” and filed on Jan. 16, 2006.

[0002] The above cross-referenced related applications are hereby incorporated by reference herein in their entirety.

STATEMENT REGARDING FEDERALLY SPONSORED RESEARCH OR DEVELOPMENT

[0003] Supported by NSF grant CCF-0431150, ONR grant N00014-02-1-0353, and AFOSR grant FA9550-04-1-014.

BACKGROUND OF THE INVENTION

[0004] 1. Field of the Invention

[0005] The invention relates to imaging devices such as cameras, video cameras, microscopes, and other visualization techniques, and more particularly, to the acquisition of images and video using fewer measurements than previous techniques.

[0006] 2. Brief Description of the Related Art

[0007] The large amount of raw data acquired in a conventional digital image or video often necessitates immediate compression in order to store or transmit that data. This compression typically exploits a priori knowledge, such as the fact that an N -pixel image can be well approximated as a sparse linear combination of $K \ll N$ wavelets. These appropriate wavelet coefficients can be efficiently computed from the N pixel values and then easily stored or transmitted along with their locations. Similar procedures are applied to videos containing F frames of P pixels each; we let $N=FP$ denote the number of video “voxels”.

[0008] This process has two major shortcomings. First, acquiring large amounts of raw image or video data (large N) can be expensive, particularly at wavelengths where CMOS or CCD sensing technology is limited. Second, compressing raw data can be computationally demanding, particularly in the case of video. While there may appear to be no way around this procedure of “sample, process, keep the important information, and throw away the rest,” a new theory known as Compressive Sensing (CS) has emerged that offers hope for directly acquiring a compressed digital

representation of a signal without first sampling that signal. See Candès, E., Romberg, J., Tao, T., “Robust uncertainty principles: Exact signal reconstruction from highly incomplete frequency information,” *IEEE Trans. Inform. Theory* 52 (2006) 489-509; David Donoho, “Compressed sensing,” *IEEE Transactions on Information Theory*, Volume 52, Issue 4, April 2006, Pages: 1289-1306; and Candès, E., Tao, T., “Near optimal signal recovery from random projections and universal encoding strategies,” (2004) Preprint.

[0009] Traditional methods of conserving power in camera monitoring and surveillance applications have either relied upon scheduling sleeping and awake modes, or supplementary sensors such as infrared motion detectors to decide when to power on the camera. In the former case, scheduled power-off periods could result in missing an important event entirely. In the latter case, we require additional hardware that may be costly or undesirable. Moreover, in both cases the system suffers from a “power-on lag,” which delays image or video capture, potentially causing the camera to miss the important event. These problems would be solved by allowing the camera to continuously monitor the scene in a low-power, low-rate mode, and by enabling it to immediately increase its rate when an important or interesting event occurs. This kind of scheme is impossible in the traditional digital camera paradigm, which is an all-or-nothing scheme: either an image/video is captured at full rate, or no image/video is captured at all. Thus a camera that can continuously monitor at low-rate and increase to full rate with no lag-time is not found in the art, but is directly enabled by our unique camera architecture.

[0010] Other efforts on compressed imaging include Pitsianis, N. P., Brady, D. J., Sun, X.: “Sensor-layer image compression based on the quantized cosine transform,” *SPIE Visual Information Processing XIV* (2005) and Brady, D. J., Feldman, M., Pitsianis, N., Guo, J. P., Portnoy, A., Fiddy, M., “Compressive optical MONTAGE photography,” *SPIE Photonic Devices and Algorithms for Computing VII* (2005), which employ optical elements to perform transform coding of multispectral images. The hardware designed for these purposes uses concepts that include optical projections, group testing (see Cormode, G., Muthukrishnan, S., “Towards an algorithmic theory of compressed sensing,” *DIMACS Tech. Report 2005-40* (2005)), and signal inference. Two notable previous DMD-driven applications involve confocal microscopy (Lane, P. M., Elliott, R. P., MacAulay, C. E., “Confocal microendoscopy with chromatic sectioning,” *Proc. SPIE*. Volume 4959 (2003) 23-26) and micro-optoelectromechanical (MOEM) systems (DeVerse, R. A., Coifman, R. R., Coppi, A. C., Fateley, W. G., Geshwind, F., Hammaker, R. M., Valenti, S., Warner, F. J., “Application of spatial light modulators for new modalities in spectrometry and imaging,” *Proc. SPIE*. Volume 4959 (2003)).

[0011] The present invention overcomes shortcomings of the prior approaches. Preferred embodiments of the present invention take fewer measurements than prior techniques, enable significant reduction in the resources (power, computation) required for visualization and use only a small number of physical sensors. The reduction in the size of the hardware associated with preferred embodiments of the invention further may significantly reduce costs of visualization systems. The present invention can also acquire and process streaming video data (time-varying images). Finally,

the present invention can adjust its data acquisition rate according to the amount of activity in the scene it is imaging.

SUMMARY OF THE INVENTION

[0012] The present invention uses algorithms and hardware to support a new theory of Compressive Imaging (CI). The approach is based on a new digital image/video camera that directly acquires random projections without first collecting the N pixels/voxels. (See Takhar, D., Laska, J. N., Wakin, M., Duarte, M., Baron, D., Sarvotham, S., Kelly, K. K., Baraniuk, R. G., "A new camera architecture based on optical-domain compression," Proc. IS&T/SPIE Symposium on Electronic Imaging: Computational Imaging. Volume 6065. (2006)). Due to this unique measurement approach, it has the ability to obtain an image with a single detection element while measuring the image far fewer times than the number of pixels/voxels. Note also that additional embodiments using a plurality of detection elements can also be used.

[0013] The image can be reconstructed, exactly or approximately, from these random projections by using a model, in essence to find the best or most likely image (in some metric) among all possible images that could have given rise to those same measurements. While several preferred embodiments of reconstruction are described below, it should be understood that additional techniques using or incorporating the present invention can also be used.

[0014] A small number of detectors, even a single detector, can be used. Thus, the camera can be adapted to image at wavelengths of electromagnetic radiation that are currently impossible with conventional CCD and CMOS imagers. This feature is particularly advantageous, because in some cases the usage of many detectors is impossible or impractical, whereas the usage of a small number of detectors, or even a single detector, may become feasible using compressive imaging.

[0015] A camera in accordance with the present invention can also be used to take streaming measurements of a video signal, which can then be recovered using CS techniques designed for either 2-dimensional (2D) frame-by-frame reconstruction or joint 3D reconstruction. This allows a significant reduction in the computational complexity of the video encoding process.

[0016] An imaging system in accordance with the present invention enjoys a number of desirable features:

[0017] Potentially single detector or small number of detectors: By time-multiplexing each detector, we can use a less expensive and yet more sensitive photon detectors. This is particularly important when the detector is expensive, making an N -pixel array prohibitive. A single detector camera can also be adapted to image at wavelengths that are currently impossible with conventional CCD and CMOS imagers.

[0018] Universality: Random and pseudorandom measurement schemes are universal in the sense that they can be paired with any signal model. Therefore, the same encoding strategy can be applied in a variety of different sensing environments; knowledge of the nuances of the environment is needed only at the reconstruction mechanism (decoder). Random mea-

surements are also future-proof: if future research in image processing yields a better signal model then the same set of random measurements can be used to reconstruct an even better quality image or video.

[0019] Encryption: A pseudorandom sequence can be generated using a simple algorithm according to a random seed. Such encoding effectively implements a form of encryption: the randomized measurements will themselves resemble noise and cannot be decoded unless an observer knows the associated seed.

[0020] Robustness and progressivity: Random and pseudorandom measurements are robust in the sense that the measurements have equal priority, unlike the Fourier or wavelet coefficients in current transform coders. Thus they allow a progressively better reconstruction of the data as more measurements are obtained; one or more measurements can also be lost without corrupting the entire reconstruction.

[0021] Scalability: We can adaptively select how many measurements to compute in order to trade off the amount of compression of the acquired image/video versus acquisition time; in contrast, conventional cameras trade off resolution versus the number of pixel sensors.

[0022] Computational asymmetry: compressive imaging (CI) places most of its computational complexity in the decoder, which will often have more substantial computational resources than the encoder/imager. The encoder is very simple; it merely computes incoherent projections and, depending on the specific embodiment, makes few or no decisions.

[0023] Still other aspects, features, and advantages of the present invention are readily apparent from the following detailed description, simply by illustrating preferable embodiments and implementations. The present invention is also capable of other and different embodiments and its several details can be modified in various obvious respects, all without departing from the spirit and scope of the present invention. Accordingly, the drawings and descriptions are to be regarded as illustrative in nature, and not as restrictive. Additional objects and advantages of the invention will be set forth in part in the description which follows and in part will be obvious from the description, or may be learned by practice of the invention.

BRIEF DESCRIPTION OF THE DRAWINGS

[0024] For a more complete understanding of the present invention and the advantages thereof, reference is now made to the following description and the accompanying drawings, in which:

[0025] FIG. 1 is a diagram of a compressive imaging camera in accordance with a preferred embodiment of the present invention.

[0026] FIG. 2 is a diagram showing the results obtained via various imaging techniques.

[0027] FIG. 3 is a diagram showing frames from a sample video sequence obtained and reconstructed using various techniques

[0028] FIG. 4 is a flow diagram showing how a system in accordance with a preferred embodiment of the present invention determines the value of the optical inner product.

[0029] FIG. 5 is a flow diagram showing how a system in accordance with a preferred embodiment of the present invention obtains a reconstruction of an optical signal.

[0030] FIG. 6 describes a Texas Instruments digital micromirror device (DMD). FIG. 6(a) illustrates two mirrors and the mechanism that controls their tilts. A small tilting yoke, address electrodes, torsion hinges, and landing electrodes are created to control the mirror tilts. An array of such mirrors is shown in FIG. 6(b).

[0031] FIGS. 7(a)-(c) show two possible embodiments between the micromirror and photodiode. In FIG. 7(b), the protrusions would act as incoherent scatters and should only shift the overall background while the main contribution to the encoded signal on the photodiode comes from the unperturbed mirror pixels. The second, off-center configuration illustrated in FIG. 7(c) would attempt to increase the contrast ratio by reflecting the light from the mirror into the photodiode at a more oblique angle.

DETAILED DESCRIPTION OF THE PREFERRED EMBODIMENTS

[0032] In a first preferred embodiment, a camera architecture of the present invention uses for random measurements a digital micromirror array to spatially modulate an incident image and reflecting the result to a lens, which focuses the light to a single photodiode for measurement. Mathematically, these measurements correspond to inner products of the incident image with a sequence of pseudorandom patterns. For an image model the system assumes sparsity or compressibility; that is, that there exists some basis, frame, or dictionary (possibly unknown at the camera) in which the image has a concise representation. For reconstruction, this system and method uses the above model (sparsity/compressibility) and some recovery algorithm (based on optimization, greedy, iterative, or other algorithms) to find the sparsest or most compressible or most likely image that explains the obtained measurements. The use of sparsity for signal modeling and recovery from incomplete information are the crux of the recent theory of Compressive Sensing (CS), explained below.

[0033] The camera, however, does not have to rely on reflecting light off a digital micromirror device as in FIG. 1. See FIG. 4. The concept is that it can be based on any system that is capable of modulating the incident lightfield x (be it by transmission, reflection, or other means) by some series of patterns ϕ_m and then integrating this modulated lightfield at a number of points to compute the inner products $y(m) = \langle x, \phi_m^T \rangle$ between the light field and the series of patterns (the so-called “incoherent projections” $y = \Phi x$ described below). From these inner products we can recover the original signal (with fewer inner products than the number of pixels we ultimately reconstruct). Examples of systems that can modulate lightfields include digital micromirror devices, LCD shutter arrays (as in an LCD laptop projector), physically moving shutter arrays, any material that can be made more and less transparent to the lightfield of interest at different points in space, etc.

Compressive Sensing

[0034] Transform Coding

[0035] Compressive Sensing (CS) builds upon a core tenet of signal processing and information theory: that signals,

images, and other data often contain some type of structure that enables intelligent representation and processing. Current state-of-the-art compression algorithms employ a decorrelating transform to compact a correlated signal’s energy into just a few essential coefficients. Such transform coders exploit the fact that many signals have a sparse representation in terms of some basis A , meaning that a small number K of adaptively chosen transform coefficients can be transmitted or stored rather than N signal samples, where $K < N$. Mathematically, we wish to acquire an N -sample signal/image/video x for which a basis or (tight) frame $\Psi = [\psi_1, \dots, \psi_N]$ (see S. Mallat, *A Wavelet Tour of Signal Processing*, San Diego, Calif., USA: Academic Press, 1999) provides a K -sparse representation

$$x = \sum_{i=1}^k \theta_{n_i} \psi_{n_i},$$

where $\{n_i\}$ are the vector indices, each n_i points to one of the elements of the basis or tight frame, and $\{\theta_i\}$ are the vector coefficients. For example, smooth images are sparse in the Fourier basis, and piecewise smooth images are sparse in a wavelet basis; the commercial coding standards JPEG and JPEG2000 and various video coding methods directly exploit this sparsity (see Secker, A., Taubman, D. S., “Highly scalable video compression with scalable motion coding,” *IEEE Trans. Image Processing* 13 (2004) 1029-1041). For more information on Fourier, wavelet, Gabor, and curvelet bases and frames and wedgelets, see (S. Mallat, *A Wavelet Tour of Signal Processing*, San Diego, Calif., USA: Academic Press, 1999; E. Candès and D. Donoho, “Curvelets—A Surprisingly Effective Nonadaptive Representation for Objects with Edges,” *Curves and Surfaces*, L. L. Schumaker et al. (eds), Vanderbilt University Press, Nashville, Tenn.; D. Donoho, “Wedgelets: Nearly Minimax Estimation of Edges,” Technical Report, Department of Statistics, Stanford University, 1997).

[0036] We use the terms “signal” and “image” interchangeably here, since an image is two-dimensional (2D) signal. A video sequence is a sequence of images, or a 3D signal. We use the notations ϕ_m and $\phi(m)$ to denote row or column m of a matrix.

[0037] The standard procedure for transform coding of sparse signals is to (i) acquire the full N -sample signal x ; (ii) compute the complete set $\{\theta(n)\}$ of transform coefficients $\theta(i) = \langle x, \psi(i) \rangle$, where $\langle \cdot, \cdot \rangle$ denotes the inner product, $\theta(i)$ denotes the i ’th coefficient, and $\psi(i)$ denotes the i ’th basis vector (i ’th column of the matrix Ψ); (iii) locate the K largest, significant coefficients and discard the (many) small coefficients; and (iv) encode the values and locations of the largest coefficients. In cases where N is large and K is small, this procedure is quite inefficient. Much of the output of the analog-to-digital conversion process ends up being discarded (though it is not known a priori which pieces are needed).

[0038] This raises a simple question: For a given signal, is it possible to directly estimate the set of large coefficients that will not be discarded by the transform coder? While this seems improbable, the recent theory of Compressive Sensing introduced by Candès, Romberg, and Tao and Donoho

referenced above demonstrates that a signal that is K -sparse in one basis (call it the sparsity basis) can be recovered from cK nonadaptive linear projections onto a second basis (call it the measurement basis) that is incoherent with the first, where c is a small overmeasuring constant. While the measurement process is linear, the reconstruction process is decidedly nonlinear.

[0039] Incoherent Projections

[0040] In CS, we do not measure or encode the K significant $\theta(n)$ directly. Rather, we measure and encode $M < N$ projections $y(m) = \langle x, \phi_m^T \rangle$ of the signal onto a second set of basis functions, where ϕ_m^T denotes the transpose of ϕ_m . In matrix notation, we measure

$$y = \Phi x, \quad (1)$$

where y is an $M \times 1$ column vector, and the measurement basis matrix (Φ) is $M \times N$ with the m 'th row the basis vector ϕ_m . Since $M < N$, recovery of the signal x from the measurements y is ill-posed in general; however the additional assumption of signal sparsity makes recovery possible and practical. Note that using $M < N$ is the preferred embodiment, but one may also take a larger number of measurements ($M = N$ or $M > N$).

[0041] The CS theory tells us that when certain conditions hold, namely that the basis cannot sparsely represent the elements of the sparsity-inducing basis (a condition known as incoherence of the two bases) and the number of measurements M is large enough, then it is indeed possible to recover the set of large $\{\theta(n)\}$ (and thus the signal x) from a similarly sized set of measurements $\{y(m)\}$. This incoherence property holds for many pairs of bases, including for example, delta spikes and the sine waves of the Fourier basis, or the Fourier basis and wavelets. Significantly, this incoherence also holds with high probability between an arbitrary fixed basis and a randomly generated one (consisting of i.i.d. Gaussian or Bernoulli/Rademacher ± 1 vectors). Signals that are sparsely represented in frames or unions of bases can be recovered from incoherent measurements in the same fashion.

[0042] We call the rows of Φ the measurement basis, the columns of Ψ the sparsity basis or sparsity inducing basis, and the columns of $V = \Phi\Psi = [V_1, \dots, V_N]$ the holographic basis. Note that the CS framework can be extended to frames and more general dictionaries of vectors.

[0043] Signal/Image Recovery

[0044] The recovery of the sparse set of significant coefficients $\{\theta(n)\}$ can be achieved using optimization or other algorithms by searching for the signal with l_0 -sparsest coefficients $\{\theta(n)\}$ that agrees with the M observed measurements in y (recall that typically $M < N$). That is, we solve the optimization problem

$$\theta_r = \arg \min \|\theta\|_0 \text{ such that } y = \Phi\Psi\theta.$$

The l_0 norm $\|\theta\|_0$ counts the nonzero entries in the vector θ ; hence it is a measure of the degree of sparsity, with more sparse vectors having smaller l_0 norm.

[0045] Unfortunately, solving this optimization problem is prohibitively complex and is believed to be NP-hard (see Candès, E., Tao, T., "Error correction via linear programming," (2005) Preprint). The practical revelation that supports the new CS theory is that it is not necessary to solve

the l_1 -minimization problem to recover the set of significant $\{\theta(n)\}$. In fact, a much easier problem yields an equivalent solution (thanks again to the incoherency of the bases); we need only solve for the l_1 -sparsest coefficients θ that agree with the measurements y

$$\theta_r = \arg \min \|\theta\|_1, \text{ such that } y = \Phi\Psi\theta \quad (2)$$

[0046] The optimization problem (2), also known as Basis Pursuit (see Chen, S., Donoho, D., Saunders, M., "Atomic decomposition by basis pursuit," SIAM J. on Sci. Comp. 20 (1998) 33-61), is significantly more approachable and can be solved with traditional linear programming techniques whose computational complexities are polynomial in N . Although only $K+1$ measurements are required to recover sparse signals via l_0 optimization, one typically requires $M \sim cK$ measurements for Basis Pursuit with an overmeasuring factor $c > 1$.

[0047] We use the notation c to describe the overmeasuring/oversampling constant required in various settings and note the following approximation: The constant c satisfies $c \approx \log 2 (1 + N/K)$.

[0048] While reconstruction based on linear programming is one preferred embodiment, any reconstruction approach can be used in the present invention. Other examples include the (potentially more efficient) iterative Orthogonal Matching Pursuit (OMP) (see Tropp, J., Gilbert, A. C., "Signal recovery from partial information via orthogonal matching pursuit," (2005) Preprint), matching pursuit (MP) (see Mallat, S. and Zhang, Z., "Matching Pursuit with Time Frequency Dictionaries", (1993) IEEE Trans. Signal Processing 41(12): 3397-3415), tree matching pursuit (TMP) (see Duarte, M. F., Wakin, M. B., Baraniuk, R. G., "Fast reconstruction of piecewise smooth signals from random projections," Proc. SPARS05, Rennes, France (2005)) algorithms, group testing (see Cormode, G., Muthukrishnan, S., "Towards an algorithmic theory of compressed sensing," DIMACS Tech. Report 2005-40 (2005), Sudocodes (see U.S. Provisional Application Ser. No. 60/759,394 entitled "Sudocodes: Efficient Compressive Sampling Algorithms for Sparse Signals," and filed on Jan. 16, 2006), or statistical techniques such as Belief Propagation, (see Pearl, J., "Fusion, propagation, and structuring in belief networks", (1986) Artificial Intelligence, 29(3): 241-288), LASSO (see Tibshirani, R., "Regression shrinkage and selection via the lasso", (1996) J. Royal. Statist. Soc B., 58(1): 267-288), LARS (see Efron, B., Hastie, T., Johnstone, I., Tibshirani, R., "Least Angle Regression", (2004) Ann. Statist. 32(2): 407-499), Basis Pursuit with Denoising (see Chen, X., Donoho, D., Saunders, M., "Atomic Decomposition by Basis Pursuit", (1999), SIAM Journal on Scientific Computing 20(1): 33-61), expectation-maximization (see Dempster, Laird, N., Rubin, D., "Maximum likelihood from incomplete data via the EM algorithm", (1997) Journal of the Royal Statistical Society, Series B, 39(1): 1-38), and so on. These methods have also been shown to perform well on compressible signals, which are not exactly K -sparse but are well approximated by a K -term representation. Such a model is more realistic in practice.

[0049] Reconstruction can also be based on other signal models, such as manifolds (see Wakin, M, and Baraniuk, R., "Random Projections of Signal Manifolds" IEEE ICASSP 2006, May 2006, to appear). Manifold models are completely different from sparse or compressible models.

Reconstruction algorithms in this case are not necessarily based on sparsity in some basis/frame, yet signals/images can be measured using the systems described here.

[0050] The systems described here can also be used to acquire a collection of images or video sequences. Each image or video can be viewed as a point in N-dimensional Euclidean space. Therefore, the collection of images/videos forms a point cloud in N dimensional Euclidean space. Incoherent projections as implemented in our systems will keep different images/videos well-separated and preserve the neighborhood relationships among similar signals, even if we never intend to reconstruct these images/videos (see Dasgupta, S., Gupta, A., "An elementary proof of the Johnson-Lindenstrauss lemma," Tech. Rep. TR-99-006, Berkeley, Calif., 1999). The point cloud approach is useful for posing and solving decision problems with collections of images/videos, such as detection, classification, recognition, tracking, registration, and other problems.

[0051] The preferred embodiment is to reconstruct an N-pixel image or video sequence from $M < N$ measurements. Additional embodiments using more measurements are possible. For example, if we use $M = N$ or $M > N$ measurements, then the extra measurements can be used for subsequent processing. For example, additional measurements may be used for averaging or filtering when the image is noisy or corrupted in some way.

Compressive Imaging

[0052] The present invention is a new system to support what can be called Compressive Imaging (CI). In one preferred embodiment, the present invention incorporates a microcontrolled mirror array driven by pseudorandom and other measurement bases and a single or multiple photodiode optical sensor. This hardware optically computes incoherent image measurements as dictated by the CS theory; CS reconstruction algorithms are then applied to obtain the acquired images. A camera in accordance with the present invention can also be used to take streaming measurements of a video signal, which can then be recovered using CS techniques designed for either 2D frame-by-frame reconstruction or joint 3D reconstruction. Streaming video can also be supported.

[0053] Other desirable features of our system include the use of a single detector (potentially enabling imaging at new wavelengths that are currently impossible or infeasible with CCD and CMOS technology), universal measurement bases (incoherent with arbitrary sparse bases), encrypted measurements (tied to a random seed that can be kept secure), and scalable progressive reconstruction (yielding improved quality with more measurements). (See Takhar, D., Laska, J. N., Wakin, M., Duarte, M., Baron, D., Sarvotham, S., Kelly, K. K., Baraniuk, R. G., "A new camera architecture based on optical-domain compression," Proc. IS&T/SPIE Symposium on Electronic Imaging: Computational Imaging. Volume 6065. (2006).)

[0054] Camera Hardware

[0055] One possible hardware realization of the CI concept is a single detector camera; it combines a microcontrolled mirror array displaying a time sequence of M pseudorandom basis images with a single optical sensor to compute incoherent image measurements y as in (1) (see FIG. 1). By adaptively selecting how many measurements

to compute, the present invention trades off the amount of compression versus acquisition time; in contrast, conventional cameras trade off resolution versus the number of pixel sensors.

[0056] FIG. 1 shows a compressive imaging (CI) camera in accordance with a preferred embodiment of the present invention. An incident lightfield **110** corresponding to the desired image x passes through a lens **120** and is then reflected off a digital micromirror device (DMD) array **140** whose mirror orientations are modulated in the pseudorandom pattern sequence supplied by the random number generator or generators **130**. Each different mirror pattern produces a voltage at the single photodiode detector **160** that corresponds to one measurement $y(m)$. While only one photodetector is shown in FIG. 1, any number of detectors may be used, although typically, the number of photodetectors will be less than the total number of ultimate number of pixels obtained in the image. The voltage level is then quantized by an analog-to-digital converter **170**. The bit-stream produced is then communicated to a reconstruction algorithm **180**, which yields the output image **190**.

[0057] A preferred embodiment of the invention employs a Texas Instruments digital micromirror device (DMD) for generating the random modulation basis patterns. The DMD consists of a 1024×768 array of electrostatically actuated micromirrors where each mirror of the array is suspended above an individual SRAM cell. Each mirror rotates about a hinge and can be positioned in one of two states (+12 degrees and -12 degrees from horizontal); thus light falling on the DMD may be reflected in two directions depending on the orientation of the mirrors. Note that the Texas Instruments DMD is one possible embodiment, but many additional embodiments are possible.

[0058] Referring again to FIG. 1, with the help of a biconvex lens **120**, the desired image is formed on the DMD plane **140**; this image acts as an object for the second biconvex lens **150**, which focuses the image onto the photodiode **160**. The light is collected from one of the two directions in which it is reflected (e.g., the light reflected by mirrors in the +12 degree state). The light from a given configuration of the DMD mirrors **140** is summed at the photodiode **160** to yield an absolute voltage that yields a coefficient $y(m)$ for that configuration. The output of the photodiode **160** is amplified through an op-amp circuit and then digitized by a 12-bit analog to digital converter **170**. These are details of one specific embodiment of the invention. Various additional embodiments are also possible and will be apparent to those of skill in the art.

[0059] The photodiode measurements can be interpreted as the inner product of the desired image x with a measurement basis vector ϕ_m . In particular, letting $\rho(m)$ denote the mirror positions of the m -th measurement pattern, the voltage reading from the photodiode $v(m)$ can be written as

$$v(m) \propto \langle x, \phi_m \rangle + \text{DC offset} \quad (3)$$

where

$$\phi_m = 1_{\{\rho(m) = +12 \text{ degrees}\}} \quad (4)$$

and $1_{\{\cdot\}}$ is the indicator function. (The DC offset can be measured by setting all mirrors to -12 degrees; it can then be subtracted off.)

[0060] Equation (3) holds the key for implementing a compressive imaging (CI) system. For a given incident

lightfield x , we take M measurements $\{y(1), y(2), \dots, y(M)\}$ corresponding to mirror configurations $\{\rho(1), \rho(2), \dots, \rho(M)\}$ and thus measurement basis vectors $\{\phi_1, \phi_2, \dots, \phi_M\}$. Since the patterns $\rho(m)$ are programmable, we can select them to be incoherent with the sparsity-inducing basis (e.g., wavelets, curvelets, etc.). As mentioned previously, random or pseudorandom measurement patterns enjoy a useful universal incoherence property with any fixed basis, and so we employ pseudorandom ± 12 degree patterns on the mirrors. These correspond to pseudorandom 0/1 Bernoulli measurement vectors. (The measurements may easily be converted to ± 1 Rademacher patterns by setting all mirrors in $\rho(1)$ to $+12$ degrees and then letting $y(m) \Leftarrow 2y(m) - y(1)$ for $m > 1$.) Other options for incoherent CI mirror patterns include $-1/0/1$ group-testing patterns (see Cormode, G., Muthukrishnan, S.: Towards an algorithmic theory of compressed sensing. DIMACS Tech. Report 2005-40 (2005)). These are specific embodiments of mirror patterns; additional embodiments of mirror patterns can also be used.

[0061] Mirrors can also be duty-cycled to give the elements of Φ finer precision, for example to approximate Gaussian measurement vectors (see D. Donoho, "Compressed Sensing," IEEE Transactions on Information Theory, Volume 52, Issue 4, April 2006, Pages: 1289-1306; and Candès, E., Tao, T., "Near optimal signal recovery from random projections and universal encoding strategies," (2004) Preprint). This duty-cycling technique can be used to emulate inner products with any real-valued vector. Specific embodiments may generate each coefficient of such projection vectors using some continuous probability distribution, but any set of real-valued vector values can be used.

[0062] This compressive imaging system directly acquires a reduced set of M incoherent projections of an N -pixel image x without first acquiring the N pixel values. Since the camera is "progressive," better quality images (larger K) can be obtained by taking a larger number of measurements M . Also, since the data measured by the camera is "future-proof," new reconstruction algorithms based on better sparsifying image transforms can be applied at a later date to obtain even better quality images.

[0063] Streaming Video Acquisition

[0064] The CI system and method of the present invention is immediately applicable to video acquisition. As described above, the measurements are taken sequentially in time. Hence, one can view each measurement as a linear projection against a snapshot of the scene at that instant. Viewing the video as a three-dimensional (3D) signal (in which the 2D snapshots are stacked), the measurements vectors $\{\phi(m)\}$ themselves are each localized onto a different 2D snapshot for each m .

[0065] In order to recover a video sequence from these measurements, some simplifying assumptions are made. Specifically, traditional CS considers an ensemble of measurements taken from a single signal; in the streaming setting, however, each measurement will act on a different snapshot. The present invention overcomes this problem by assuming that the image changes slowly across a group of snapshots, which can then be equated to a single video frame. The number of snapshots assigned to a frame will be determined by the speed of the acquisition system and the desired temporal resolution of the reconstructed video. Under this assumption, the acquired video is represented as

a sequence of F frames, each one measured using M/F measurement vectors that we can group as rows of a matrix Ψ_i , $i=1, 2, \dots, F$. While this is one embodiment that enables to measure a video sequence; additional embodiments, some of which will be described below, are possible and will be apparent to those of skill in the art.

[0066] Several options exist for reconstructing the video from these measurements. First, one could reconstruct each frame individually using 2D wavelets, performing a total of F CI reconstructions. Each reconstruction would use the same 2D wavelet sparsity basis Ψ but with a different measurement matrix. This process will be referred to herein as frame-by-frame reconstruction.

[0067] Alternative methods more fully exploit the correlation between frames. One solution is to use 3D wavelets as a sparse representation for the video sequence; i.e., to define the joint measurement matrix

$$\Phi = \begin{bmatrix} \Phi_1 & 0 & \dots & 0 \\ 0 & \Phi_2 & \dots & 0 \\ \vdots & \vdots & \ddots & \vdots \\ 0 & 0 & \dots & \Phi_F \end{bmatrix}$$

for the video sequence and then perform joint reconstruction of the entire video sequence using a 3D wavelet sparsity basis Ψ for the frame ensemble. Despite its block diagonal structure, the 3D measurement matrix Φ enjoys sufficient incoherence with the 3D sparsity matrix Ψ . The video could also be reconstructed using the manifold-based reconstruction algorithms described above (see Wakin, M, and Baraniuk, R., "Random Projections of Signal Manifolds" IEEE ICASSP 2006, May 2006, to appear).

[0068] The compressive imaging architecture and method of the present invention can also be extended to acquire full 3D measurements of a video sequence (that is, where each has 3D support). One embodiment of such 3D measurements would combine inner products sampled at different times, but other embodiments are possible.

[0069] Under this setting with full 3D measurements, the entire video sequence is reconstructed using a single measurement matrix Φ that operates on all of the frames and a suitable 3D sparse basis Ψ such as wavelets. Below, it is demonstrated that such a scheme enjoys better incoherence with the video structure. However, it also increases the complexity of both the measurement and reconstruction processes. Possible solutions to this increased complexity include partitioning the video into blocks, which are then reconstructed separately.

EXAMPLES

Example 1

Still Image Acquisition

[0070] For an imaging experiment, we displayed a printout of the letter "R" in front of the camera; FIG. 2(a) shows the printout. For acquisition and reconstruction, we use an imaging resolution of $N=64 \times 64=4096$. Since our test image is piecewise constant (with sharp edges) it can be sparsely

represented in the wavelet domain. FIGS. 2(b) and 2(c) show the best K-term Haar wavelet approximation of the idealized image in FIG. 2(a) with K=205 and 409, respectively. Using M=819 and 1,638 measurements (roughly 4× the K used in (b) and (c)), we reconstructed the images shown in FIGS. 2(e) and 2(f) using the Dantzig Selector (see Candès, E., Tao, T., “The Dantzig selector: Statistical estimation when p is much larger than n,” (2005) Preprint), a robust scheme for CS reconstruction. In all cases Haar wavelets were used for approximation or reconstruction. This preliminary embodiment confirms the feasibility of the CI approach; resolution of minor calibration and noise issues will improve the reconstruction quality in future embodiments.

Example 2

Video Simulation

[0071] To demonstrate the potential for applications in video encoding, we present a series of simulations for video measurement/reconstruction. FIG. 3(a) shows a single frame taken from our F=64 frame video sequence that consists of P=64×64 images; in total the video contains N=FP=262,144 3D voxels. The video shows a disk moving from top to bottom and growing from small to large. We measure this video sequence using a total of M measurements, either 2D random measurements (with M/F measurements/frame) or 3D random measurements. (For the 2D measurements, we make the simplifying assumption that the image remains constant across all snapshots within a given frame.) To reconstruct the video from these measurements we compare two approaches: 2D frame-by-frame reconstruction using 2D wavelets as a sparsity-inducing basis and 3D joint reconstruction using 3D wavelets as a sparsity-inducing basis.

[0072] FIG. 3 shows Matching Pursuit reconstruction results using M=20,000 (top row) and M=50,000 (bottom row). Comparing columns (b) and (c), we observe that 3D wavelets offer a significant improvement in reconstruction quality over 2D wavelets; we attribute this improvement to the ability of 3D wavelets to capture correlations between frames. Comparing columns (c) and (d), we also observe that full 3D measurements allow better reconstruction than frame-by-frame 2D measurements; we believe this improvement is due to the better incoherency between the measurement basis and the wavelet basis. Fortunately, this improvement is somewhat moderate, which indicates that 2D frame-by-frame measurements (easily obtained from our hardware) may contain sufficient information for high-quality video reconstruction, presuming that a joint 3D technique is used for reconstruction. This embodiment can be extended by developing better joint reconstruction techniques, perhaps by using algorithms for Distributed CS (see Baron, D., Wakin, M. B., Duarte, M. F., Sarvotham, S., Baraniuk, R. G., “Distributed compressed sensing” (2005)) for video reconstruction.

[0073] As shown in FIG. 4, the optical signal to be acquired 410 runs through the focusing lens 420 which is focused onto the Masking/Modulation Device 430. This device is configured according to the chosen optical modulation sequence 440. The reflection of the image on the device performs a pixel-wise multiplication 450 of the values of the optical signal 410 and the optical modulation

sequence 440, and a new optical product signal is obtained. This optical signal is focused by a second lens 460 onto a single optical sensing element 470, which registers the sum of the absolute values of the entries in the product signal, thus returning the value of the inner product 480.

Adaptive Compressive Imaging Scheme

[0074] An alternative adaptive compressive imaging scheme embodiment that takes more and more measurements until image/video reconstruction is possible is described.

[0075] As shown in FIG. 5, the adaptive imaging apparatus takes the optical signal to be acquired 510, and a specified optical modulation sequence 520, and performs an optical inner product of these two signals 530 to obtain a projection value. The projection value is stored 540 and the apparatus checks whether the number of projections necessary for reconstruction has been reached 550. If it has not, then the apparatus employs a new specified optical modulation sequence 522 to obtain new projection values. If it has, then the projection values and the modulation sequences 520 are fed into the reconstruction algorithm 560, which obtains a reconstruction of the optical signal 570. Many possible embodiments for adapting the number of measurements to the specific signal can be used.

Attention Based Processing

[0076] One way to save power is to use the camera only when it is needed. Blindly turning the power off except for periodic wakeup intervals is easily accommodated in our design, but this is too crude for many modern sensing applications.

[0077] Another approach is to monitor instances of change. For many applications, the received image light field may not change for long periods of time, or the images may change very slowly, allowing a slower data acquisition rate. For example, a camera used to monitor an infrequently used stairwell does not really need to report the same image of the stairwell over and over. However, if a burglar enters the stairwell, then the camera will need to awake abruptly when the scene changes. To conserve the power consumed by the analog-to-digital converter, the computation determining when the camera should wake up should be as simple as possible, using low-power analog processing and/or low-rate digital processing. Essentially, the camera needs a startle reflex: a quick reaction mode involving little overhead or computation.

[0078] The CI camera is ideally suited to implement a startle reflex. Simply put, the values or statistics of coefficients at the analog-to-digital converter output, running at a very slow, low-power rate, would be compared with previous values or statistics to determine whether the scene being monitored has changed. Algorithms for achieving this could range from very simple statistical (parametric and non-parametric) tests, for example a test based on an energy detector, a test based on empirical entropies (see Gutman, M., “Asymptotically Optimal Classification for Multiple Tests with Empirically Observed Statistics,” IEEE Trans. Inform. Theory 35 (1989) 401-408), or more sophisticated tests based on detailed models of motion. It is also possible that measurement systems other than pseudo-random, ones more adapted to natural images, may give rise to more predictable distributions of values for natural images; thus,

any such algorithms could be enhanced by using a carefully designed basis in the analog-to-digital converter. Moreover, rather than simply detecting a change, different bases could be exploited to provide a more detailed analysis of different kinds of change, allowing a richer set of decision rules to control the camera's rate.

[0079] A simple embodiment (outlined below) based on the empirical entropy decision rule developed by Gutman (see Gutman above) is described. Experiments have shown that even small changes in images can be detected at an extremely low sampling rate, much lower than would be required to reconstruct the image for viewing. Thus, using only a few (potentially highly quantized) coefficients from the analog-to-digital converter, one can implement an effective startle reflex leading to drastic power savings in applications like monitoring and surveillance. Other statistical tests are also possible beyond the Gutman test.

[0080] The startle-reflex algorithm may be described as follows:

[0081] 1. Collect S samples of a sequential measurement vector y , quantized to B bits per measurement. This is the training sample.

[0082] 2. Compute the empirical probability distribution of the training sample.

[0083] 3. Collect the next S samples of y . This is the testing sample.

[0084] 4. Compute the empirical probability distribution of the testing sample.

[0085] 5. Compute the empirical entropy test statistic (see Gutman above).

[0086] 6. If the test statistic exceeds a threshold T , then increase camera to full sampling rate and capture image. Replace training sample with testing sample.

[0087] 7. Otherwise, form a new training sample by concatenating the old training sample with the testing sample.

[0088] 8. Repeat steps 2-8.

[0089] The startle-reflex algorithm above can be implemented quite simply and demands very little by way of sensing and computation. Yet, it has proven to be highly effective at detecting changes in sequences of images, even at very low measurement rates. For example, typical values of the parameters examined during simulations were: $S=30$ samples, 6 coefficients in y , and 3 bit (8 level) uniform scalar quantization of each coefficient. These values yielded good performance in many sequences of test images, correctly rejecting up to 50% of the images when no change had occurred

[0090] These specific values and the startle-reflex algorithm above are specific embodiments of attention based processing. Additional embodiments may use different parameter values and/or test statistic algorithms differing from that of Gutman (see Gutman above).

[0091] Attention based processing is not limited to turning a CI camera on and off. Additional embodiments may use the attention information for additional purposes, for example to track different phenomena in space and/or time.

Micromirror Modulation for Imaging

[0092] Current imaging devices rely on CCD or CMOS technology for the optical sensing element. While the scale and cost of this technology is continually reducing, the complexity and power requirements have not similarly scaled. Digital micromirror devices have proven to be a commercially viable MEMs technology for the video/projector display market (see D. Doherty and G. Hewlett, "Phased reset timing for improved digital micromirror device (DMD) brightness," in *SID Symposium Digest*, vol. 29, p. 125). Inspired by the success of this technology, a wide range of MEMs structure for the manipulation of optical signals has been produced. In particular, piezoelectrically driven membrane mirrors have proven powerful tools for wavefront engineering in laser systems (see C. Radzewicz, P. Wasylczyk, W. Wasilewski, and J. Krasinski, "Piezo-driven deformable mirror for femtosecond pulse shaping," *Optics Letters*, vol. 29, pp. 177-179, January 2004), for adaptive optics in telescopes and microscopes (see B. Frazier, R. Tyson, M. Smith, and J. Roche, "Theory and operation of a robust controller for a compact adaptive optics system," *Optical Engineering*, vol. 43, pp. 2912-2920, December 2004; J. Perreault, T. Bifano, B. Levine, and et al., "Adaptive optic correction using microelectromechanical deformable mirrors," *Optical Engineering*, vol. 41, pp. 561-566, March 2002; M. Horenstein, S. Pappas, A. Fishov, and et al., "Electrostatic micromirrors for subaperturing in an adaptive optics system," *J. of Electrostatics*, vol. 54, pp. 321-332, March 2002; J. M. G. P. N. March, D. Burns, "Practical implementation of adaptive optics in multiphoton microscopy," *Optics Express*, vol. 11, pp. 112-1130), and for switching in information technology devices (see L. Yoder, W. Duncan, E. Koontz, J. So, T. Bartlett, B. Lee, B. Sawyers, D. Powell, and P. Rancuret, "DLPTM technology: Applications in optical networking," in *Proc. SPIE*, vol. 4457, pp. 54-61, 2001). An embodiment of the present invention exploits the incorporation of a microcontrolled mirror (driven by either piezoelectrics or electrostatics) with an optical sensor so that it can additionally acquire images, instead of adapting current camera technology to be employed as an optical sensor. The material below describes such a preferred embodiment, which is an alternative to the embodiment using DMD arrays described above.

[0093] Photodiode Sensing Element: By replacing the optical sensor array with a single sensing element (in this case a photodiode), we have greatly reduced the complexity. In shifting the complexity of the camera away from the signal receiving portion and into the signal acquisition/interpretation areas, we are able to work with less expensive and more sensitive photon detectors. The advantages of a photodiode sensing element include low-power, low cost, high photon sensitivity that increases with the diode volume, and very fast response times. Modern photodiodes are routinely operated at hundreds of megahertz and have been extended into the GHz regime. The cost of photodiodes can be as little as \$0.50 a chip with the cost increasing with the performance capabilities; still, a very good quality photodiode is around \$15. In addition, having one optical receiving element allows us to increase the detection efficiency by increasing its size.

[0094] Additional applications of this technology occur in the cases where power and cost are not limited. The single photodiode can be replaced with a quadrant photodiode for

higher spatial resolution. In specialty applications where greater photon sensitivity may be preferred and cost is not a consideration, the normal photodiode may be replaced with an avalanche photodiode to allow single photon counting. For photodiodes, a variety of semiconductor materials are available, allowing the sensitivity to span the optical, UV, and IR spectrums with equal capabilities. While the initial prototype will be grayscale, the conversion of this device to a full color camera has been straightforward. For proof of concept we have implemented color imaging in our architecture with RGB filters mounted on a color wheel. However, many other color technologies may also be adapted with our imaging architecture. Our realization of these technologies is due to the broad spectral response of the micromirror and photodiode. Many possible embodiments exist for full-color implementation including a series of prisms to separate the signal between 3 separate photodiodes. In a similar manner we can easily extend the capabilities of our camera for more detailed multispectral or hyperspectral imaging. Any image signal that can be shuttered by an incoherent pattern and then summed at the detector is suitable acquisition and reconstruction by our proposed methods.

[0095] Color image/video reconstruction can be facilitated by the fact that the color channels share common information (they are correlated or “jointly sparse”). Therefore, the techniques of distributed compressed sensing could be used to lower the number of measurements required for color data acquisition (see Baron, D., Wakin, M. B., Duarte, M. F., Sarvotham, S., Baraniuk, R. G., “Distributed compressed sensing” (2005).

[0096] There are also alternative embodiments of photodiodes, some of which we describe here. Photodiodes can be implemented in a variety of circuit configurations depending on the application. Output voltage could be set up to be proportional to logarithmic change in the detected light level, the external circuit could be optimized to emphasize the converting the light signal to frequency, or an x-ray scintillation detector could be mounted in front of the photodiode for medical or astronomy applications (with the appropriate modifications to the mirror coating). These are specific embodiments; additional specific embodiments of photodiodes are possible.

[0097] Digital Micromirror Devices: The Texas Instruments Digital Micromirror Device (DMD) is composed of an array of electrostatically actuated micromirrors that has found a great deal of success in the projection screen market (see D. Doherty and G. Hewlett, “Phased reset timing for improved digital micromirror device (DMD) brightness,” in *SID Symposium Digest*, vol. 29, p. 125; L. Hornbeck, “Current status of the digital micromirror device (DMD) for projection television applications,” *International Electron Devices Technical Digest*, p. 1993, 15.1.1; J. Sampsell, “An overview of the digital micromirror device (DMD) and its application to projection displays,” in *1993 SID International Symposium Digest of Technical Papers*, vol. 24, p. 1012, 1993). Each mirror **610**, **620** in a two-dimensional (x-y) array of mirrors is suspended above an individual SRAM cell in an x-y array of memory cells on a substrate **660**. Electrostatic forces are created between the mirrors and address electrodes connected to the SRAM nodes at which the “1” or “0” voltages appear. These forces twist the mirrors one way or the other about an axis through the torsion hinges

630 until the rotation is stopped at a precise angle determined by one mirror edge or the other touching the underlying substrate. A small tilting yoke **640**, springs **650**, address electrodes, torsion hinges **630**, and landing electrodes are created to control the mirror tilt (this is shown in **FIG. 6(a)**). A second sacrificial polymer layer is deposited onto this aluminum layer and vias are created from the surface of that layer to the center of each yoke **640**. A square mirror is fabricated integral to the post formed by each via. Two sacrificial layers are removed simultaneously, leaving mirrors that tilt as before (as the yokes they ride on are tilted) but that minimize light diffracted from the underlying structure. An array of such mirrors is shown in **FIG. 6(b)**. This mirror structure has been migrated to the 768×576 pixel DMD, and contrast ratios from both front and rear projection systems based on such mirrors routinely exceed 100:1.

[0098] These devices are well above and beyond the necessary requirements of pixel density and contrast ratio for our proposed device. However, any micromirror array, either electrostatically or piezoelectrically driven, is suitable for our camera architecture. Similar driving mechanisms may also be suitable for our camera architecture.

[0099] Piezoelectric Deformable Mirror: As an alternative to electrostatic manipulation in MEMs devices, piezoelectric materials offer a similar ability to convert electrical signals into mechanical work. At the same time, they are able to actuate at much greater frequencies compared to electrostatic based systems. A piezoelectric transducer can reach its nominal displacement in $\frac{1}{3}$ of the period of the resonant frequency. Depending on the final size and scale of the transducers, these frequencies could correspond to a time on the order of microseconds. Electrostatic structures are still favored in MEMs applications due to the ease of the incorporation with traditional IC manufacturing technologies. The overall goal of our micromirror system is not increased miniaturization and its correspondingly greater pixel density, although a commercial version of the DMD based on piezoelectric has been explored (see Y. J. S. K. H. Hwang and S. G. Kim, “Thin-film micromirror array for high-brightness projection displays,” *Jpn. J. Appl Phys.*, vol. 37, pp. 7074-7077, 1998). It is instead a low-fidelity and low-cost acquisition and transmission of the original image.

[0100] We envision two possible embodiments between the micromirror **710** and photodiode **720** shown in **FIG. 7(a)**. These are two specific example embodiments; additional extensions are possible.

[0101] **FIG. 7(b)**, the protrusions in the switching mirror **710** would act as incoherent scatters and should only shift the overall background while the main contribution to the encoded signal on the photodiode comes from the unperturbed mirror pixels. However, the angle of reflection between the lenses **730**, **740** and mirror must not be too shallow, otherwise the undeformed neighboring pixels on the mirror might be shadowed by their protruding neighbors. Of course in a second configuration we can exploit this to block the light from the neighboring pixels. This effectively would represent a lateral shift in the white noise basis by one vector.

[0102] The second, off-center configuration of the switching mirror illustrated in **FIG. 7(c)** would attempt to increase the contrast ratio by reflecting the light from the mirror into the photodiode at a more oblique angle. In this instance, the

switching mirror bears more of a resemblance to a tunable diffraction grating (see C. W. Wong, Y. Jeon, G. Barbastathis, and S. G. Kim, "Analog tunable gratings driven by thin-film piezoelectric microelectromechanical actuators," *Applied Optics*, vol. 42, pp. 621-626, 2003). After various modeling and testing, the most appropriate device structure will be adopted. As well as physical characterization, we will build upon previously derived models (see G. Vdovin and P. Sarro, "Flexible mirror micromachined in silicon," *Applied Optics*, vol. 34, pp. 2968-2972, June 1995; C. Paterson, I. Munro, and J. C. Dainty, "A low cost adaptive optics system using a membrane mirror," *Optics Express*, vol. 6, pp. 175-185, 2000) for flexible membrane light scattering and apply it to our system using appropriate software and matrix optics. This second configuration represents a modulation of the signal by binary white-noise, similar to the DMD modulation where the former configuration represents modulation by Gaussian white-noise. Recovery of the original image by compressed sensing techniques is valid for both.

[0103] Another possible embodiment includes a micro-controller that drives the mirror motions in such a manner that the mirror surface structure forms a time-varying 2D smooth surface. Controlling the mirror structure to conform to the desired smooth surface will enable the mirror angle to vary smoothly between spatially close-by locations on the mirror surface. Therefore, in contrast to the measurement via discretely-computed inner products mentioned before, in this system the device will sense the continuous integral of the optical signal modulated by the mirror surface waveform. This capability will enable advanced analog measurement techniques. This integral can be written as an inner product not between two discrete, length-N vectors but between two continuously varying 2D functions.

[0104] Another possible embodiment is to perform image acquisition using real-space convolution with white-noise as a shuttering mechanism and recorded by an individual detector.

[0105] Previous embodiments were presented as reflecting light. Additional embodiments can reflect other frequencies and even electron imaging. In another embodiment, an image may be formed using a similar modulation of a (potentially micro-electromechanical) shutter array placed directly over the detector. This would create an essentially flat camera. In fact, the modulation mechanism of our image signal in transmission mode would apply well beyond the optical regime allowing for construction of a camera out of a single sensor in regimes where reflective optical elements do not exist, such as gamma rays.

FURTHER EMBODIMENTS

[0106] Compressive imaging can be incorporated in distributed systems with multiple imaging devices. This will enable reconstruction of multiple images (e.g., multiple frames of a video sequence) using fewer measurements than before, requiring reduced resource consumption (e.g. power reduction). Alternatively, these techniques could enable better image reconstruction quality.

[0107] Power reduction can be achieved by minimizing the amount of mirror motion. One way to do this is to specifically design measurement matrices such that adjacent rows are as similar as possible to one another.

[0108] The foregoing description of the preferred embodiment of the invention has been presented for purposes of illustration and description. It is not intended to be exhaustive or to limit the invention to the precise form disclosed, and modifications and variations are possible in light of the above teachings or may be acquired from practice of the invention. The embodiment was chosen and described in order to explain the principles of the invention and its practical application to enable one skilled in the art to utilize the invention in various embodiments as are suited to the particular use contemplated. It is intended that the scope of the invention be defined by the claims appended hereto, and their equivalents. The entirety of each of the aforementioned documents is incorporated by reference herein.

What is claimed is:

1. A method for acquiring an image or video sequence from incoherent projections comprising the steps of:
 - modulating an incident light field by a series of patterns;
 - optically computing inner products between the light field and said series of patterns; and
 - reconstructing an image or video sequence based upon said inner products.
2. A method for acquiring an image or video sequence from incoherent projections according to claim 1 wherein said image or video sequence is reconstructed with fewer inner products than a number of pixels or voxels reconstructed.
3. A method for acquiring an image or video sequence according to claim 1, wherein said step of optically computing inner products comprises integrating the modulated light field at a number of points.
4. A method for acquiring an image or video sequence according to claim 1, wherein said step of optically computing inner products comprises transmitting light through some material.
5. A method for acquiring an image or video sequence according to claim 1, wherein said step of optically computing inner products comprises reflecting light off an array of reflective surfaces, where each surface corresponds to an area of said image being integrated.
6. A method for acquiring an image or video sequence according to claim 1, wherein said step of optically computing inner products comprises reflecting light off a contoured surface.
7. A method for acquiring an image or video sequence according to claim 1, further comprising the steps of:
 - taking additional measurements; and
 - using said additional measurements for subsequent processing.
8. A method for acquiring an image or video sequence according to claim 7, wherein said subsequent processing comprises filtering, averaging or other processing.
9. An imaging system comprising:
 - means for modulating an incident light field by a series of patterns;
 - means for optically computing inner products between the light field and a series of patterns; and
 - means for recovering a signal based upon said inner products.

10. An imaging system according to claim 9, wherein said means for modulating comprises at least one of a digital micromirror device array, an LCD shutter array, and a physically moving shutter array.

11. An imaging system according to claim 9, wherein said means for modulating comprises a material that can be made more or less transparent to a light field of interest at different points in space.

12. An imaging system according to claim 9, wherein said means for recovering a signal comprises:

a single sensing element; and

a processor for applying a reconstruction algorithm to signals received from said single sensing element.

13. An imaging system according to claim 12, wherein said single sensing element comprises a photodiode.

14. An imaging system according to claim 9, wherein said means for recovering a signal recovers a signal using fewer measurements than a number of pixels or voxels to be recovered.

15. An imaging system according to claim 9, wherein said means for recovering a signal comprises:

a plurality of sensing elements; and

a processor for applying a reconstruction algorithm to signals received from said plurality of sensing elements.

16. An imaging system according to claim 15, wherein said plurality of sensing elements comprise a number of photodetectors.

17. An imaging system according to claim 15, wherein said plurality of sensing elements comprise a number of stacked photodetectors.

18. An imaging device comprising:

a lens;

a digital micromirror device array;

means for modulating mirror orientations of said digital micromirror device array in an incoherent pattern sequence;

a pattern generator for supplying incoherent patterns to said means for modulating;

a sensor element, wherein each different mirror pattern produces a voltage at the sensor element that corresponds to a measurement;

an analog-to-digital converter for quantizing said voltage; and

a reconstruction means for reconstructing an image based upon a bitstream received from said analog-to-digital converter.

19. An imaging device according to claim 18, wherein said image is a color, multispectral or hyperspectral image or a color, multispectral or hyperspectral video sequence.

20. An imaging device according to claim 18, wherein said reconstruction means comprises a processor for performing a reconstruction algorithm.

21. An imaging device according to claim 20, wherein said reconstruction algorithm comprises at least one of a Greedy reconstruction algorithm, Matching Pursuit, Orthogonal Matching Pursuit, Basis Pursuit, group testing, LASSO, LARS, expectation-maximization, Bayesian estimation algorithm, belief propagation, wavelet-structure exploiting algorithm, Sudocode reconstruction, reconstruction based on manifolds, l_1 reconstruction, l_0 reconstruction, and l_2 reconstruction.

22. An imaging device according to claim 18, where said lens comprises a biconvex lens.

23. An imaging device according to claim 18, further comprising a second lens for focusing an image onto said sensing element.

24. An imaging device according to claim 18, wherein said means for modulating comprises measurement matrices having most adjacent rows similar to one another.

25. An imaging device according to claim 18, wherein said means for modulating comprises at least one of discrete valued measurement matrices, real valued measurement matrices, randomly distributed matrices with real values, randomly distributed matrices with discrete values, random Bernoulli-distributed matrices, random Gaussian-distributed matrices, permutation matrices, modulation matrices, structured binary matrices, sparse matrices, Sudocode matrices, code matrices, parity check matrices, and matrices having adjacent rows designed to minimize the power required to transition from one pattern to the next.

26. An imaging device comprising:

a sensing element; and

means for focusing light onto said sensing element for measurement;

wherein measurements taken by said sensing element correspond to inner products of an incident image with a sequence of incoherent patterns.

27. A method of acquiring a signal comprising the steps of:

measuring and encoding projections of a signal that is compressible in a first set of basis functions onto a second set of basis functions, wherein said second set of basis functions is incoherent with said first set of basis functions;

reconstructing said signal based upon said projections.

28. A method for acquiring a signal according to claim 27 wherein said signal is a signal of two or more dimensions

29. A method for acquiring a signal according to claim 27 wherein said reconstructing step is based on at least one of a Greedy reconstruction algorithm, Matching Pursuit, Orthogonal Matching Pursuit, Basis Pursuit, group testing, LASSO, LARS, expectation-maximization, Bayesian estimation algorithm, belief propagation, wavelet-structure exploiting algorithm, Sudocode reconstruction, reconstruction based on manifolds, l_1 reconstruction, l_0 reconstruction, and l_2 reconstruction.

* * * * *