



US 20060196375A1

(19) **United States**

(12) **Patent Application Publication**
Coe-Sullivan et al.

(10) **Pub. No.: US 2006/0196375 A1**

(43) **Pub. Date: Sep. 7, 2006**

(54) **METHOD AND SYSTEM FOR
TRANSFERRING A PATTERNED MATERIAL**

Related U.S. Application Data

(76) Inventors: **Seth Coe-Sullivan**, Belmont, MA (US);
Moungi G. Bawendi, Cambridge, MA
(US); **Vladimir Bulovic**, Lexington,
MA (US)

(60) Provisional application No. 60/620,697, filed on Oct.
22, 2004. Provisional application No. 60/629,579,
filed on Nov. 22, 2004.

Publication Classification

(51) **Int. Cl.**
B41K 1/38 (2006.01)
(52) **U.S. Cl.** **101/327**

Correspondence Address:
STEPTOE & JOHNSON LLP
1330 CONNECTICUT AVENUE, N.W.
WASHINGTON, DC 20036 (US)

(57) **ABSTRACT**

A method of transferring a material to a substrate includes selectively depositing the material on a surface of an applicator and contacting the surface of the applicator to the substrate. The material can form a pattern on the surface of the applicator. The pattern can be preserved when the material is transferred to the substrate. The material can be deposited on the applicator by ink jet printing.

(21) Appl. No.: **11/253,612**

(22) Filed: **Oct. 20, 2005**

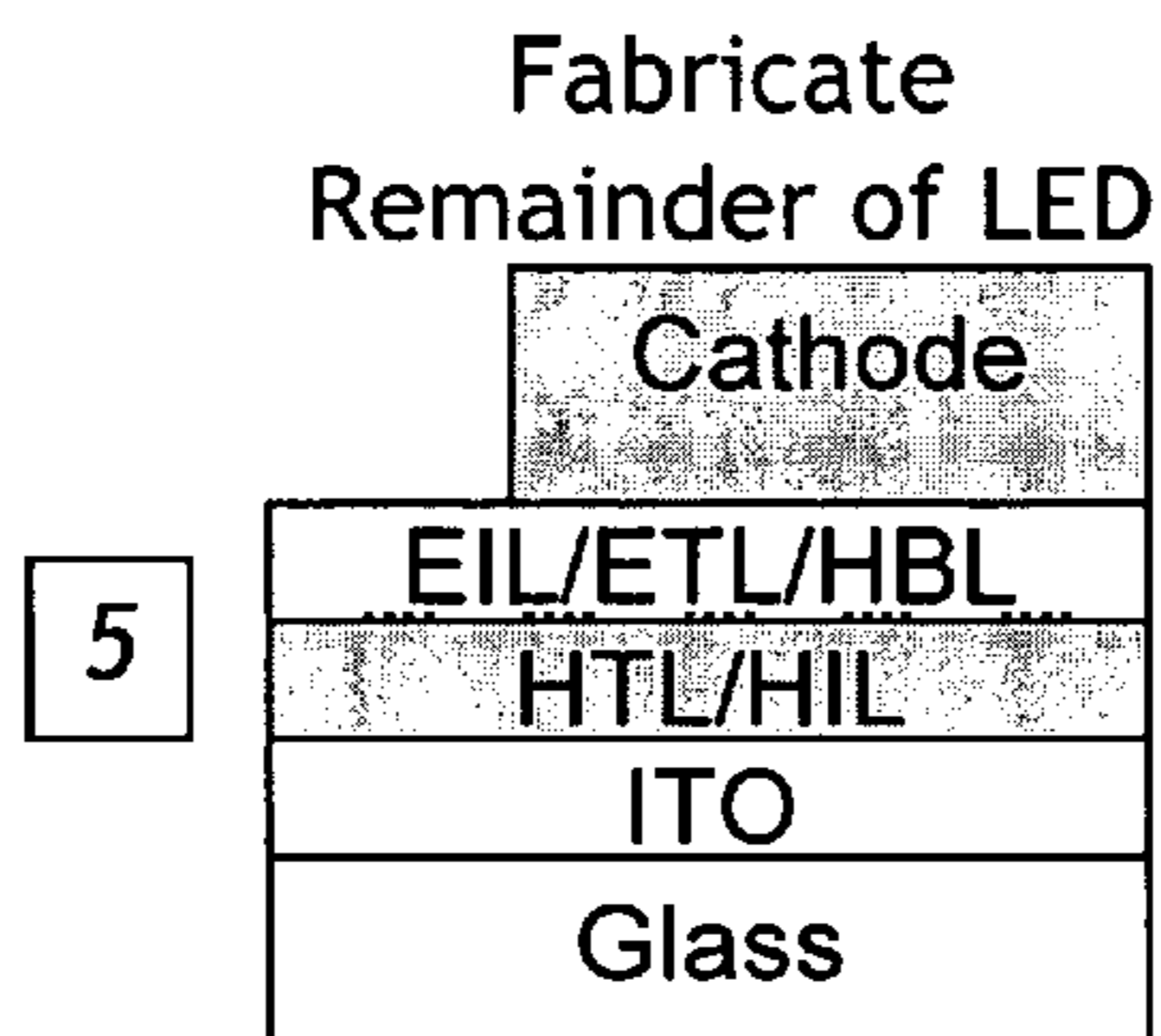
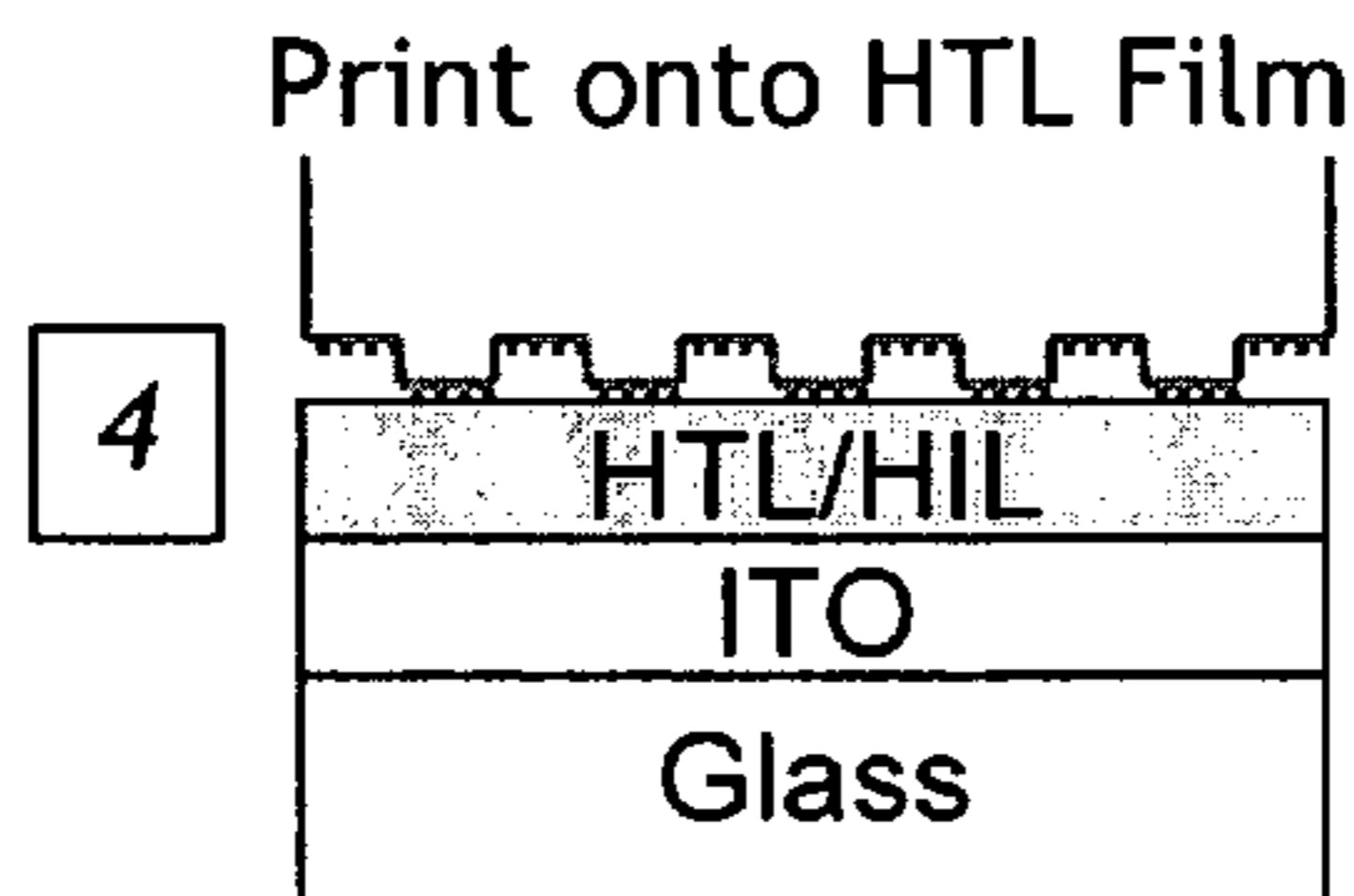
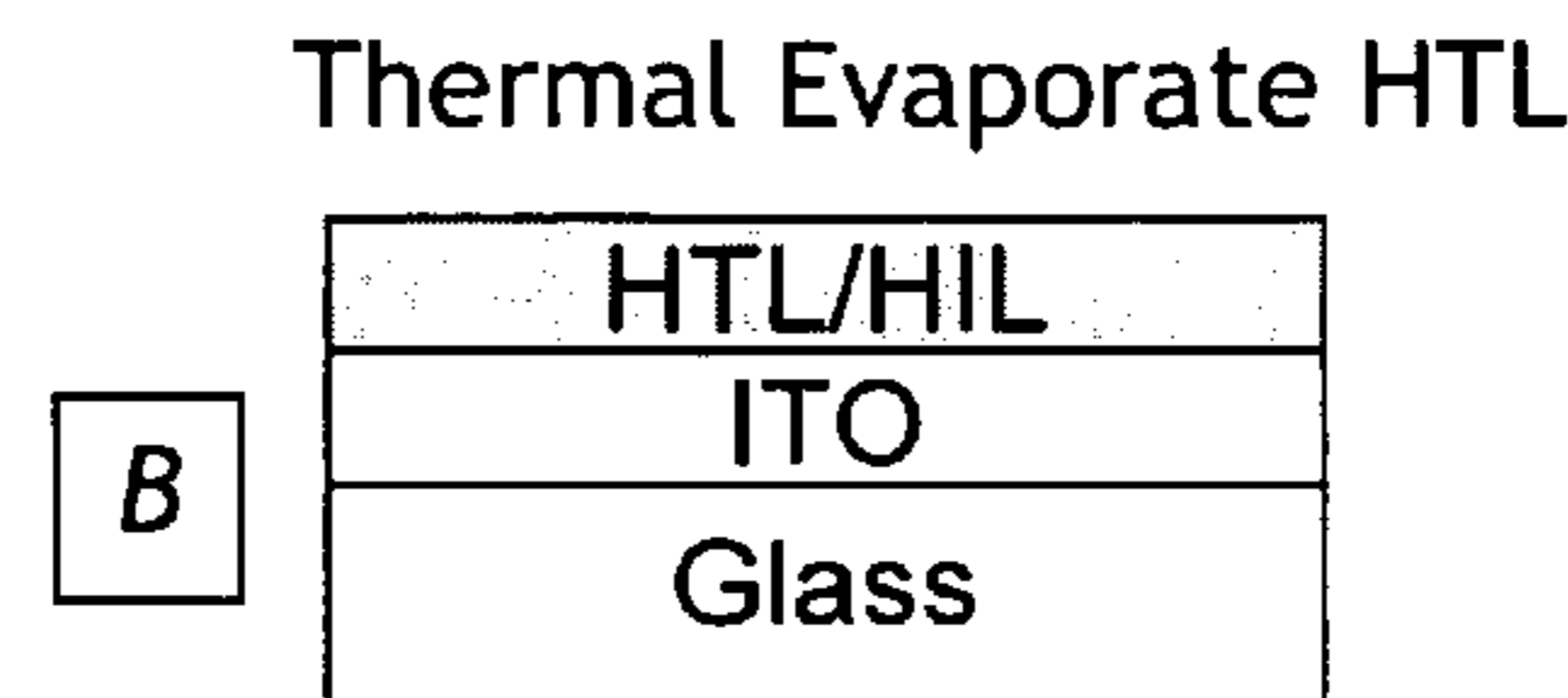
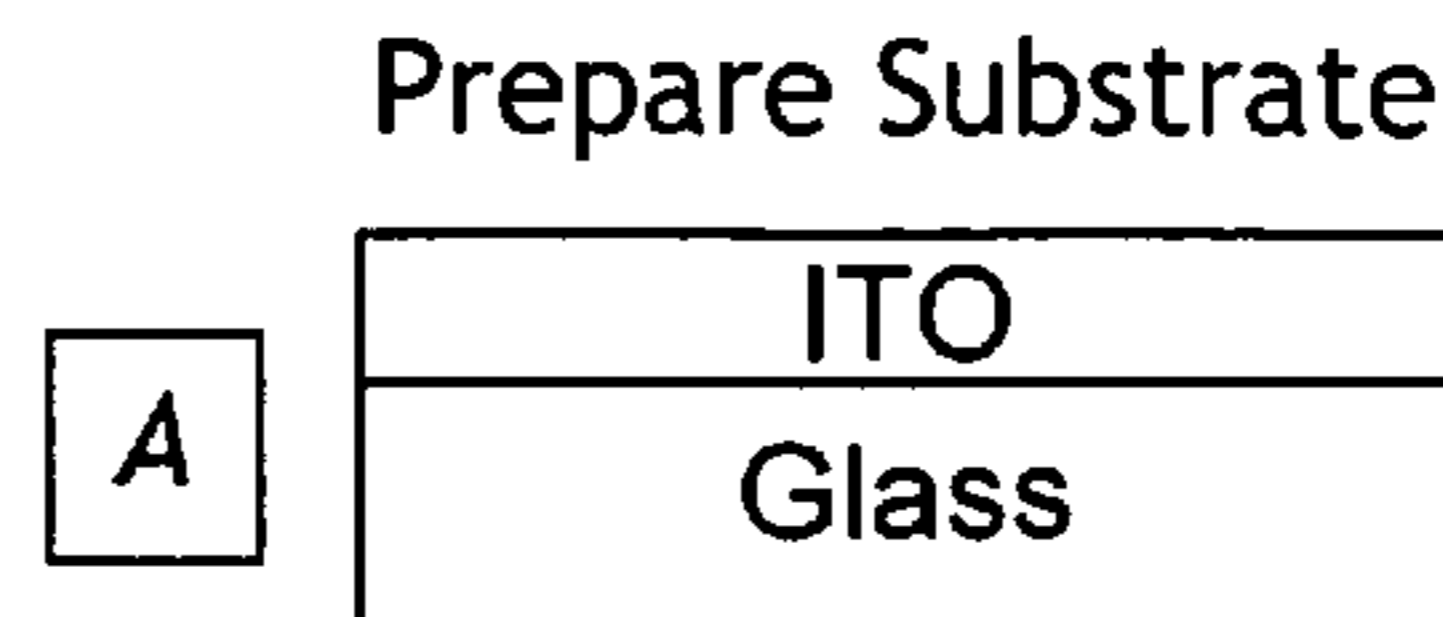
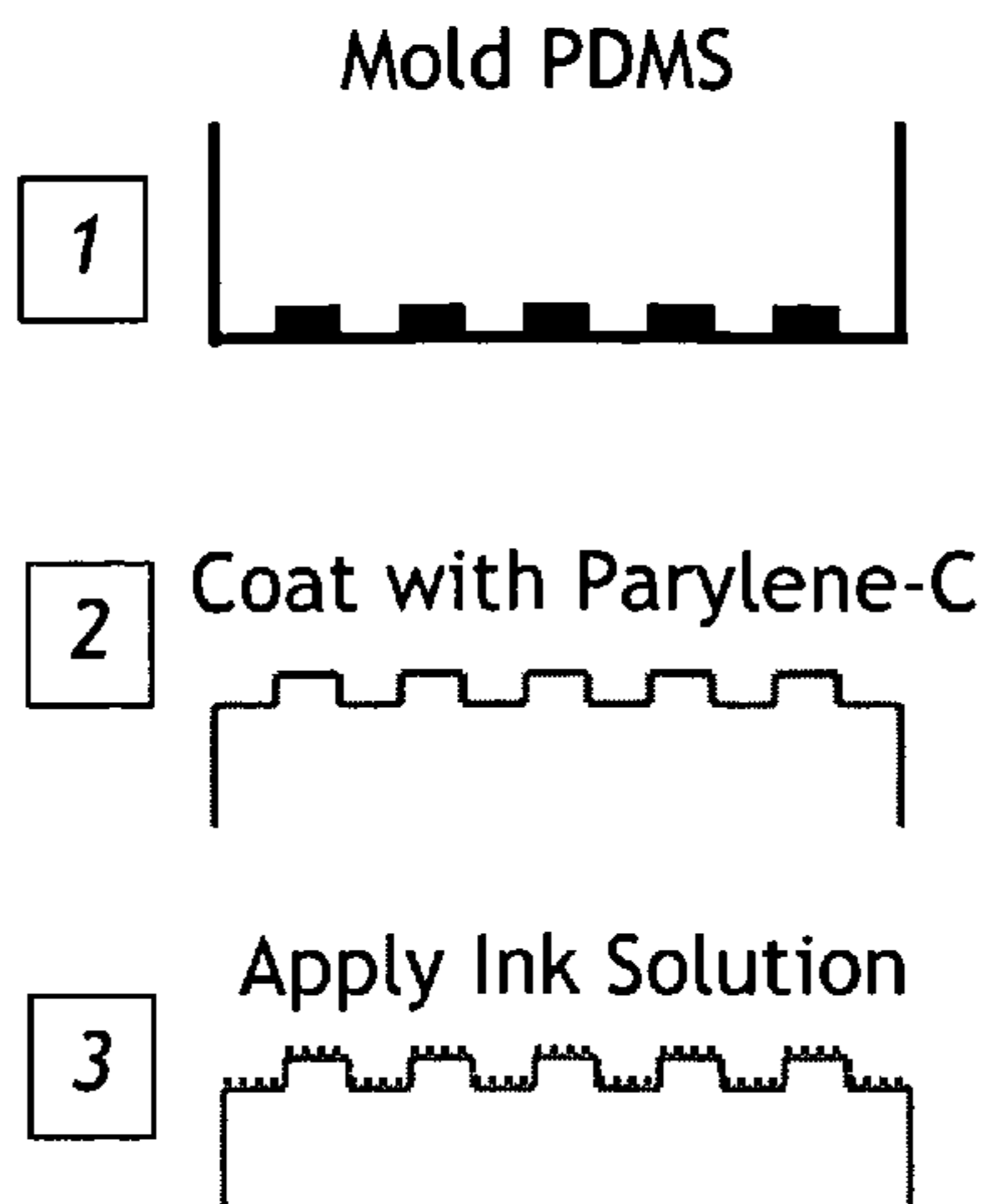

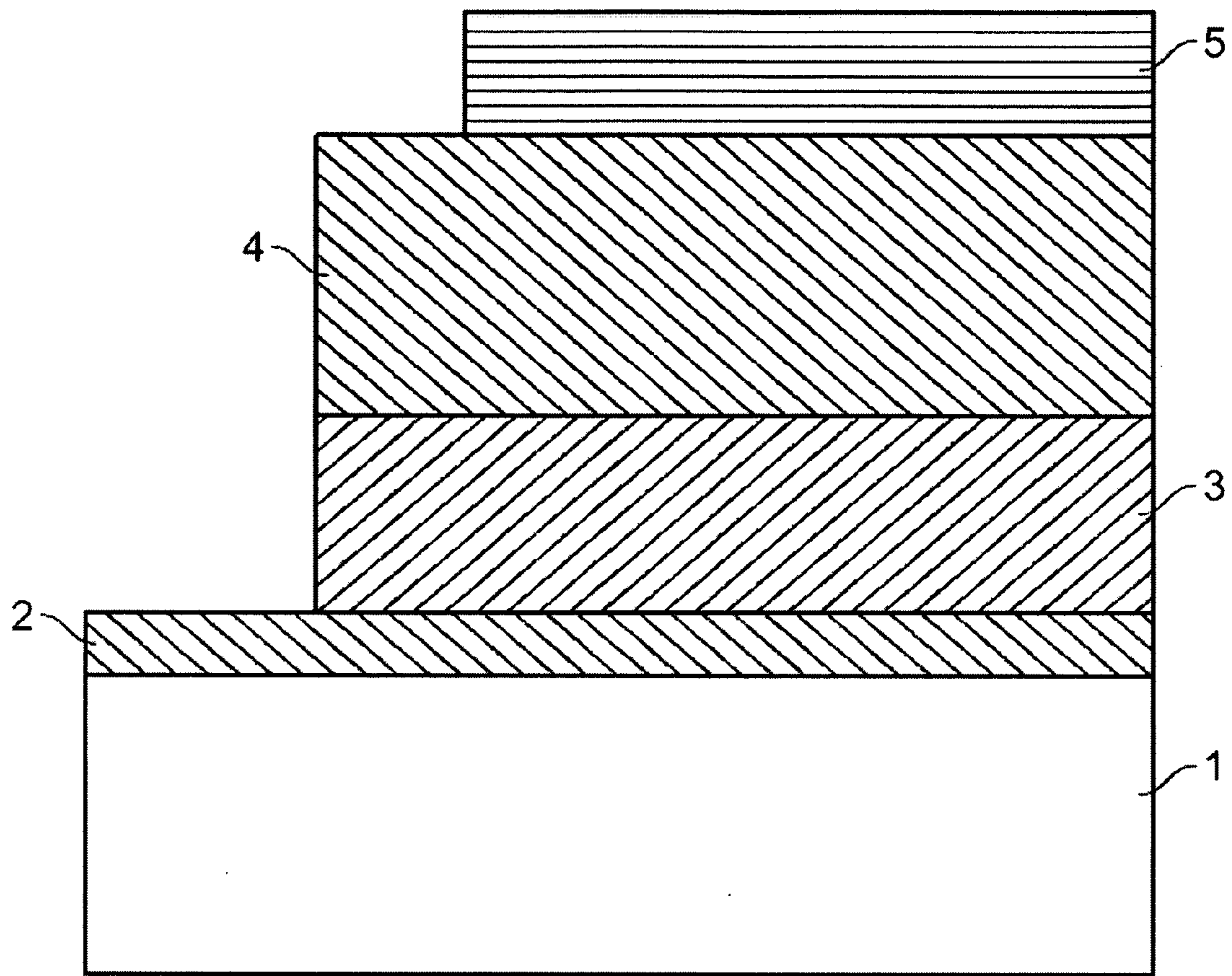

FIG. 1

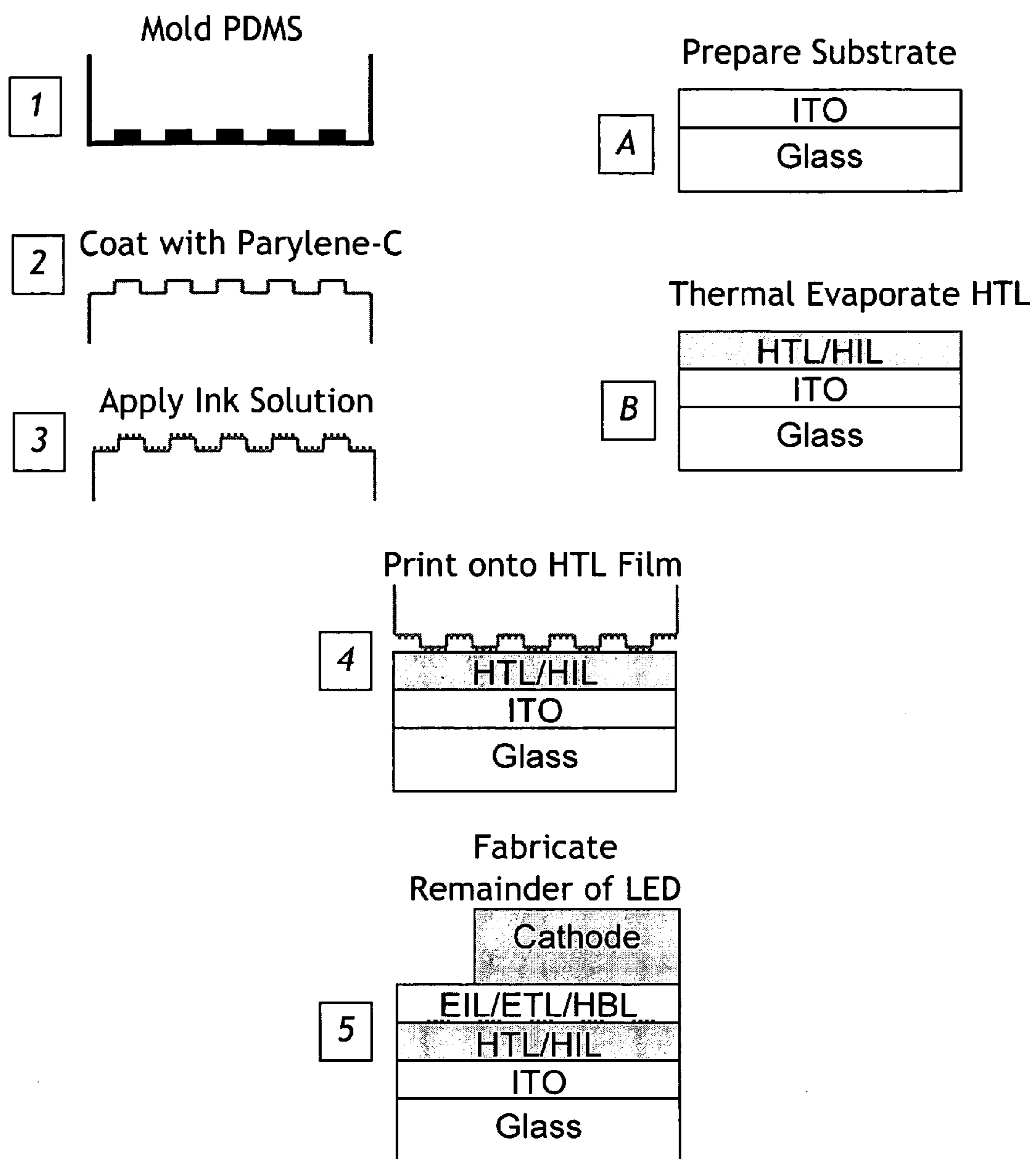
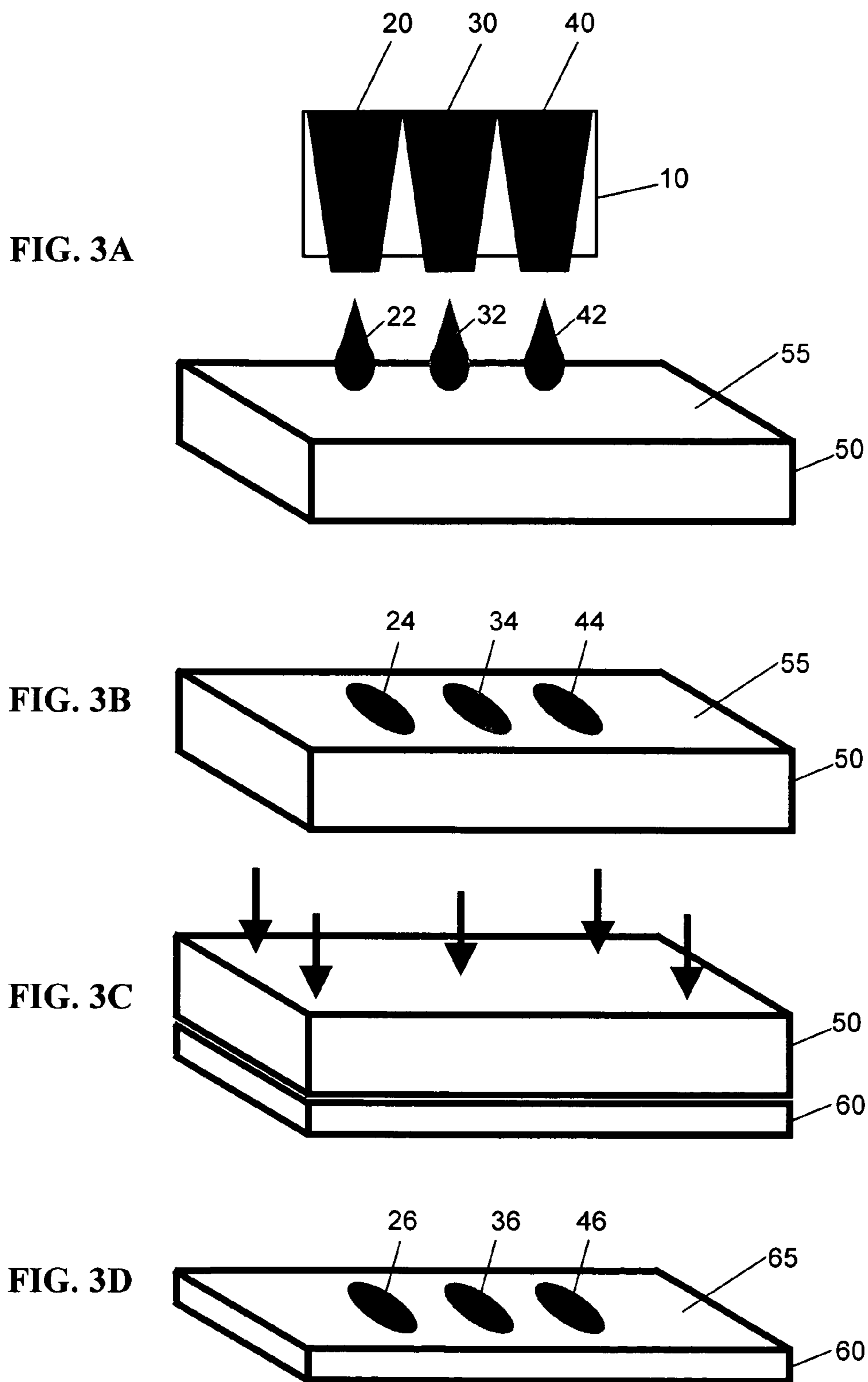

FIG. 2



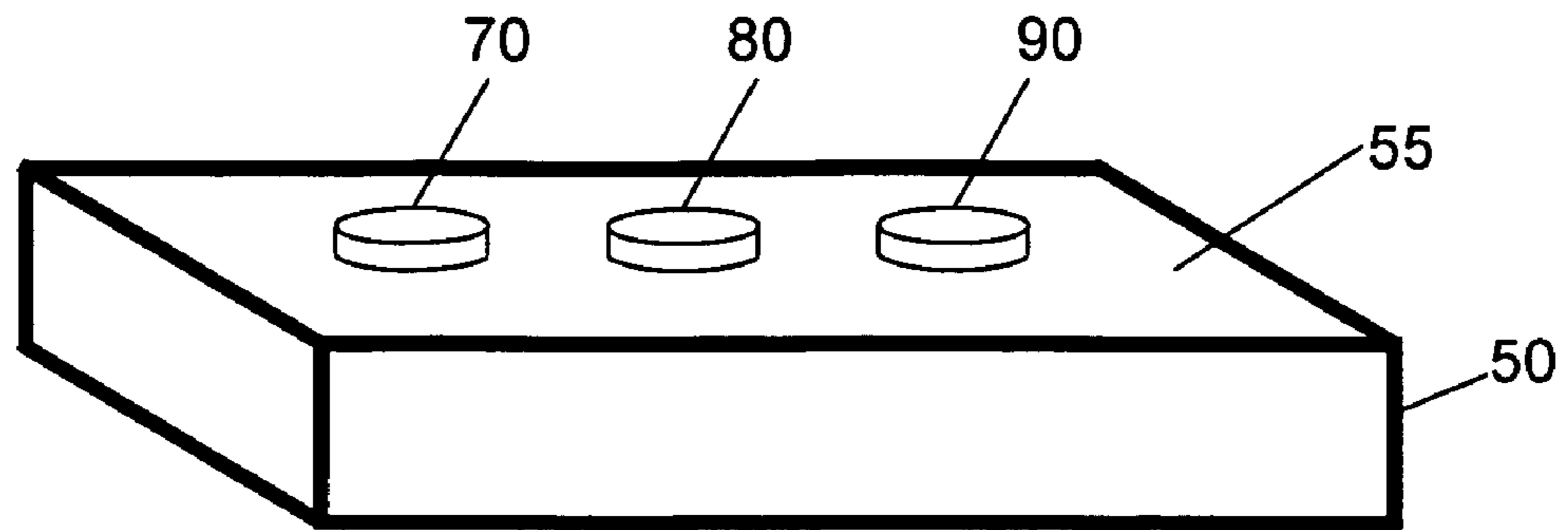

FIG. 4A

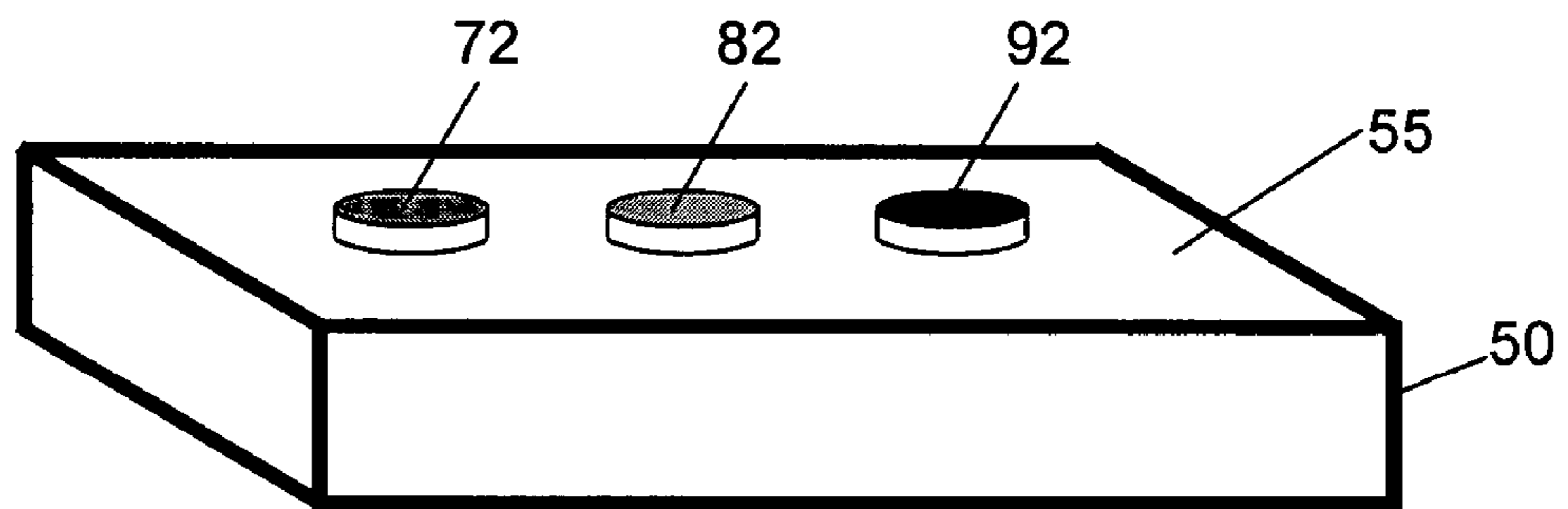

FIG. 4B

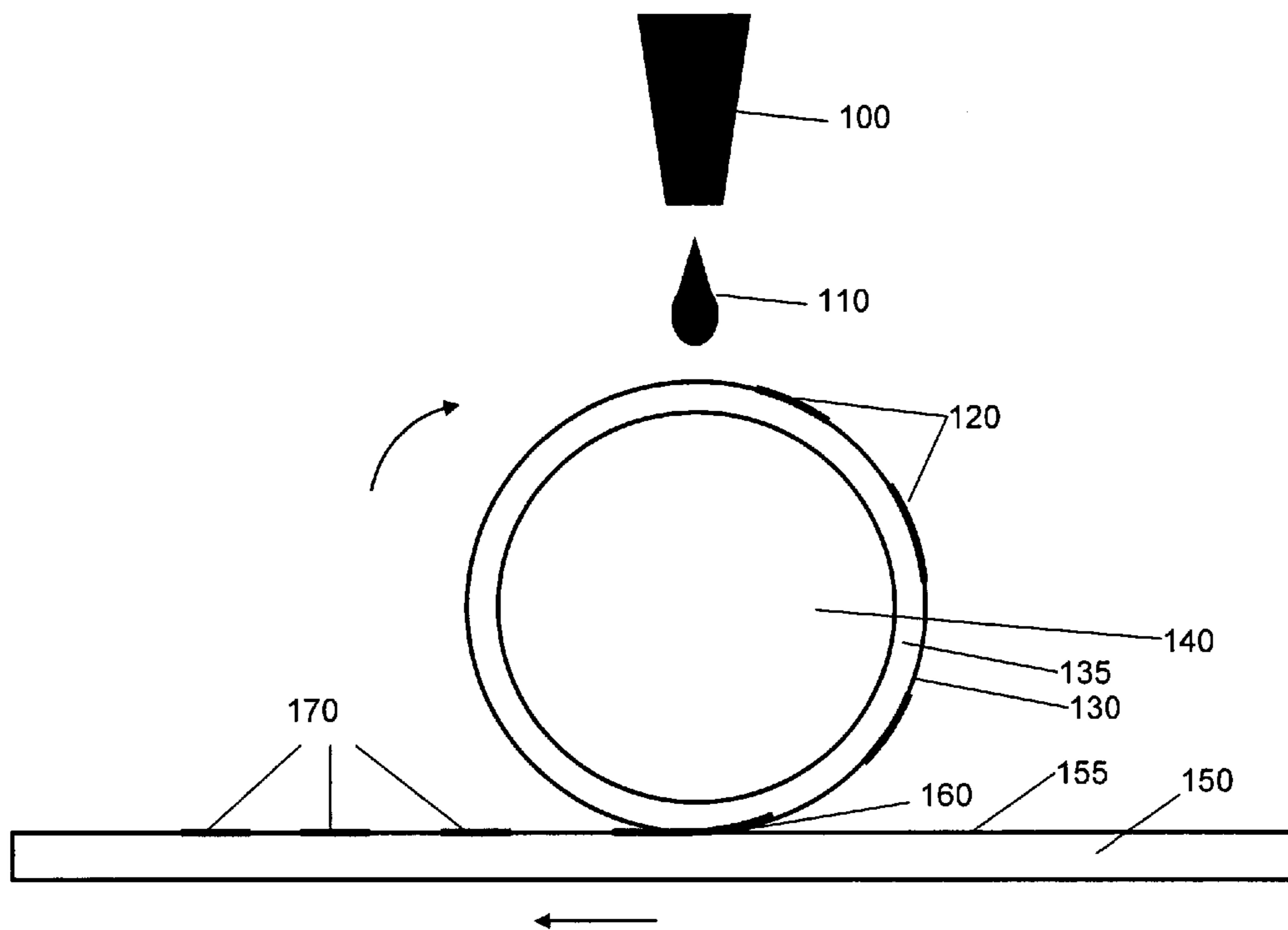

FIG. 5

METHOD AND SYSTEM FOR TRANSFERRING A PATTERNED MATERIAL

CLAIM OF PRIORITY

[0001] This application claims priority to provisional U.S. patent application No. 60/620,967, filed Oct. 22, 2004, and to provisional U.S. patent application No. 60/629,579, filed Nov. 22, 2004, each of which is incorporated by reference in its entirety.

FEDERALLY SPONSORED RESEARCH OR DEVELOPMENT

[0002] The U.S. Government may have certain rights in this invention pursuant to Grant No. 6896872 from the National Science Foundation.

TECHNICAL FIELD

[0003] The present invention relates to a method and system for transferring a patterned material.

BACKGROUND

[0004] In general, contact printing begins by forming a patterned mold. The mold has a surface with a pattern of elevations and depressions. A stamp is formed with a complementary pattern of elevations and depressions by coating the patterned surface of the mold with a liquid polymer precursor that is cured while in contact with the patterned mold surface. The stamp can then be uniformly inked; that is, the stamp is contacted with a material which is to be deposited on a substrate, covering the pattern of elevations and depressions. The material becomes reversibly adhered to the stamp. The inked stamp is then contacted with the substrate. The elevated regions of the stamp can contact the substrate while the depressed regions of the stamp can be separated from the substrate. Where the inked stamp contacts the substrate, the ink material (or at least a portion thereof) is transferred from the stamp to the substrate. In this way, the pattern of elevations and depressions is transferred from the stamp to the substrate as regions including the material and free of the material on the substrate.

SUMMARY

[0005] A material can be deposited on a substrate using contact printing. Contact printing using a textured stamp allows micron-scale (e.g., less than 1 mm, less than 500 μm , less than 200 μm , or less than 100 μm or less) patterning of features on a surface. This approach allows the dry (i.e., solvent free) application of a patterned material to a substrate, thus freeing the substrate of solubility and surface chemistry requirements. For example, a monolayer of semiconductor nanocrystals can be deposited by contact printing. For examples of contact printing, see U.S. patent application 60/620,967, filed Oct. 22, 2004, which is incorporated by reference in its entirety.

[0006] A material can be selectively applied to a stamp such that the material forms a pattern on the stamp. The material can be included in a composition with other components, for example, as a solution in a solvent. For example, the material can be applied by ink jet printing, which allows a pattern of material (ink) to be conveniently formed on a stamp. Ink jet printing can allow precise control over the location and size of inked areas on the stamp. Ink

spots of 20 μm in size are readily achieved today by commercial inkjet printers, and smaller spot sizes are possible. Thus, contact printing using a stamp patterned by ink jet printing can be used to form patterns of a material on substrate, where the pattern is a micropattern. A micropattern can have features on the micron scale, such as less than 1 mm, less than 500 μm , less than 200 μm , less than 100 μm , less than 50 μm , or 20 μm or less in size. A 20 μm feature size is sufficiently small for most light emitting device applications. Different materials can be patterned on the substrate simultaneously using an ink jet print system having multiple print heads. Thus, multiple materials can be transferred to a substrate in a single stamping step. This method can allow the use of a featureless stamp (i.e., a stamp substantially free of elevations or depressions) patterned by multiple print heads to transfer multiple materials to a substrate, rather than using a separate stamp for each material. Thus, there is no need to register subsequent stamps to the previously deposited patterns. Registration of a stamp with a previously formed pattern on a substrate can be the limiting factor in the resolution of contact printing. The pattern can have features 100 nm in size; however, registration to 100 nm resolution of elastomeric materials over large areas has never been demonstrated.

[0007] Microcontact printing can be used to apply a material in a pattern having micron scale features across large dimensions, such as 1 cm or greater, 10 cm or greater, 100 cm or greater, or 1,000 cm or greater.

[0008] Mechanical limitations on patterned-stamp contact printing can be overcome when a pattern is formed on a featureless stamp. When a textured stamp contacts a substrate, any applied pressure (necessary to achieve material transfer) is distributed in predictable but non-uniform ways. This induced stress can cause sagging of the stamp in the areas not in contact with the substrate surface. If the applied pressure is great enough, the sagging areas can contact the substrate surface, resulting in material transfer in undesired regions. In contrast, pressure applied to a stamp that is substantially free of elevations and depression leads to uniformly distributed forces over the stamped area, and thus sagging and other non-uniform processes can be reduced or eliminated.

[0009] Contact printing of semiconductor nanocrystal monolayers can be used to make saturated color red, green and blue LEDs including semiconductor nanocrystals, place multiple such LEDs of different colors onto a single substrate, and form LED patterns at the micron scale (<100 μm). The deposition process is scalable, and can allow inexpensive manufacturing of LEDs over a large surface area.

[0010] In one aspect, a method of transferring a material to a substrate includes depositing the material selectively on a surface of an applicator, and contacting the surface of the applicator with the substrate.

[0011] In another aspect, a method of transferring a plurality of materials to a substrate includes depositing a first material selectively on a surface of an applicator, depositing a second material selectively on the surface of the applicator, and contacting the surface of the applicator with the substrate.

[0012] The material can be substantially free of solvent before contacting. Depositing the material selectively can

include forming a pattern including the material on the surface of the applicator. A feature of the pattern can have a dimension of less than 1000 micrometers, less than 100 micrometers, or less than 10 micrometers. Forming the pattern can include ink jet printing the material. The surface of the applicator can include an elevation or a depression. The surface of the applicator can be substantially free of elevations and depressions. The applicator can include an elastomeric material.

[0013] The method can include depositing a second material selectively on the surface of the applicator. The second material can be substantially free of solvent before contacting. Depositing the second material selectively can include forming a pattern on the surface of the applicator. Depositing the second material can include ink jet printing. The surface of the applicator can be in continuous contact with the substrate. The material can include a semiconductor nanocrystal.

[0014] The method can include modifying the surface of the applicator before depositing the material selectively on the surface of the applicator. Modifying the surface of the applicator can include contacting the surface of the applicator with a composition selected to release at least a portion of the material from the applicator upon contact with a substrate. The composition includes an aromatic organic polymer. The material can include a nanomaterial. The nanomaterial can include a semiconductor nanocrystal.

[0015] In another aspect, a system for transferring a material to a substrate includes an ink jet print head including a reservoir, wherein the reservoir holds the material, and an applicator having a surface arranged to receive the material from the ink jet print head.

[0016] The system can include a substrate arranged to contact the surface of the applicator. The applicator can be configured to move the surface of the applicator with respect to the ink jet print head. The applicator can be mounted on a drum, the drum being configured to rotate. The surface of the applicator can be configured to roll on the substrate. The surface of the applicator includes an elevation or a depression, or the applicator can be substantially free of elevations and depressions. The surface of the applicator can be configured to be in continuous contact with the substrate.

[0017] In another aspect, a method of making a light emitting device includes ink jet printing a material on a surface of an applicator, and contacting the surface of the applicator with a substrate. Ink jet printing the material can include forming a pattern on the surface of the applicator. The material can include a light emitting material. The light emitting material can include a semiconductor nanocrystal. The substrate can include an electrode, a hole transport material, an electron transport material, a hole injection material, an electron injection material, or a combination thereof.

[0018] In another aspect, a device for applying a material includes an applicator and a material forming a pattern on a surface of the applicator. The surface of the applicator can include an elevation or a depression. The surface of the applicator can be substantially free of elevations or depressions. The applicator can include an elastomeric material. The device can include a second material forming a pattern on the surface of an applicator

[0019] Other features, objects, and advantages of the invention will be apparent from the description and drawings, and from the claims.

DESCRIPTION OF DRAWINGS

[0020] FIG. 1 is a schematic drawing depicting a light-emitting device.

[0021] FIG. 2 is a diagram depicting a method of forming a light-emitting device.

[0022] FIGS. 3A-3D are diagrams depicting a method of depositing a material on a substrate.

[0023] FIGS. 4A-4B are diagrams depicting a stamp for contact printing.

[0024] FIG. 5 is a diagram depicting a system for depositing a material on a substrate.

DETAILED DESCRIPTION

[0025] In general, a light emitting device can include a plurality of semiconductor nanocrystals. Semiconductor nanocrystals consist are nanometer-scale inorganic semiconductor particles which are typically decorated with a layer of organic ligands. These zero-dimensional semiconductor structures show strong quantum confinement effects that can be harnessed in designing bottom-up chemical approaches to create complex heterostructures with electronic and optical properties that are tunable with the size and composition of the nanocrystals.

[0026] The semiconductor nanocrystals can be used as the lumophore in a light emitting device. Because semiconductor nanocrystals have narrow emission linewidths, are photoluminescent efficient, and emission wavelength tunable, they can be a desirable lumophore. Semiconductor nanocrystals can be dispersed in solution and are therefore compatible with thin-film deposition techniques such as spin-casting, drop-casting, and dip coating. However, neat semiconductor nanocrystal solids resulting from these deposition techniques have poor electrical transport properties in solid state light emitting devices. Rather than a neat solid, a monolayer of semiconductor nanocrystals can be used in a light emitting device. A monolayer provides the beneficial light emission properties of semiconductor nanocrystals while minimizing the impact on electrical performance.

[0027] Semiconductor nanocrystal monolayers are typically self-assembled out of solution, such as by spin-casting, Langmuir-Blodgett techniques, or drop-casting. Some techniques for depositing semiconductor nanocrystal monolayers can place constraints on the substrate used, require the addition of chemicals that effect the electrical or optical properties of the layer, subject the substrate to harsh conditions, or constrain the types of devices that can be grown in some way. Furthermore, these techniques do not allow the monolayer to be laterally patterned. These two traits make the available techniques less than ideal for assembly of multiple color LEDs on a single substrate, or for device engineering.

[0028] A light emitting device can include two layers separating two electrodes of the device. The material of one layer can be chosen based on the material's ability to transport holes, or the hole transporting layer (HTL). The material of the other layer can be chosen based on the

material's ability to transport electrons, or the electron transporting layer (ETL). The electron transporting layer typically includes an electroluminescent layer. When a voltage is applied, one electrode injects holes (positive charge carriers) into the hole transporting layer, while the other electrode injects electrons into the electron transporting layer. The injected holes and electrons each migrate toward the oppositely charged electrode. When an electron and hole localize on the same molecule, an exciton is formed, which can recombine to emit light.

[0029] A light emitting device can have a structure such as shown in FIG. 1, in which a first electrode 2, a first layer 3 in contact with the electrode 2, a second layer 4 in contact with the layer 3, and a second electrode 5 in contact with the second layer 4. First layer 3 can be a hole transporting layer and second layer 4 can be an electron transporting layer. At least one layer can be non-polymeric. Alternatively, a separate emissive layer (not shown in FIG. 1) can be included between the hole transporting layer and the electron transporting layer. One of the electrodes of the structure is in contact with a substrate 1. Each electrode can contact a power supply to provide a voltage across the structure. Electroluminescence can be produced by the emissive layer of the heterostructure when a voltage of proper polarity is applied across the heterostructure. First layer 3 can include a plurality of semiconductor nanocrystals, for example, a substantially monodisperse population of nanocrystals. Alternatively, a separate emissive layer can include the plurality of nanocrystals. A layer that includes nanocrystals can be a monolayer of nanocrystals.

[0030] Light emitting devices including semiconductor nanocrystals can be made by spin-casting a solution containing the HTL organic semiconductor molecules and the semiconductor nanocrystals, where the HTL formed underneath of the semiconductor nanocrystal monolayer via phase separation (see, for example, U.S. patent application Ser. Nos. 10/400,907 and 10/400,908, both filed Mar. 28, 2003, each of which is incorporated by reference in its entirety). This phase separation technique reproducibly placed a monolayer of semiconductor nanocrystals between an organic semiconductor HTL and ETL, thereby effectively exploiting the favorable light emission properties of semiconductor nanocrystals, while minimizing their impact on electrical performance. Devices made by this technique were limited by impurities in the solvent, by the necessity to use organic semiconductor molecules that are soluble in the same solvents as the semiconductor nanocrystals. The phase separation technique was unsuitable for depositing a monolayer of semiconductor nanocrystals on top of both a HTL and a HIL (due to the solvent destroying the underlying organic thin film). Nor did the phase separation method allow control of the location of semiconductor nanocrystals that emit different colors on the same substrate. Similarly, the phase separation method did not allow patterning of the different color emitting nanocrystals on the same substrate.

[0031] The substrate can be opaque or transparent. The substrate can be rigid or flexible. The substrate can be plastic, metal or glass. The first electrode can be, for example, a high work function hole-injecting conductor, such as an indium tin oxide (ITO) layer. Other first electrode materials can include gallium indium tin oxide, zinc indium tin oxide, titanium nitride, or polyaniline. The second electrode can be, for example, a low work function (e.g., less

than 4.0 eV), electron-injecting, metal, such as Al, Ba, Yb, Ca, a lithium-aluminum alloy (Li:Al), or a magnesium-silver alloy (Mg:Ag). The second electrode, such as Mg:Ag, can be covered with an opaque protective metal layer, for example, a layer of Ag for protecting the cathode layer from atmospheric oxidation, or a relatively thin layer of substantially transparent ITO. The first electrode can have a thickness of about 500 Angstroms to 4000 Angstroms. The first layer can have a thickness of about 50 Angstroms to about 1000 Angstroms. The second layer can have a thickness of about 50 Angstroms to about 1000 Angstroms. The second electrode can have a thickness of about 50 Angstroms to greater than about 1000 Angstroms.

[0032] The electron transporting layer (ETL) can be a molecular matrix. The molecular matrix can be non-polymeric. The molecular matrix can include a small molecule, for example, a metal complex. For example, the metal complex can be a metal complex of 8-hydroxyquinoline. The metal complex of 8-hydroxyquinoline can be an aluminum, gallium, indium, zinc or magnesium complex, for example, aluminum tris(8-hydroxyquinoline) (Alq_3). Other classes of materials in the ETL can include metal thioxinoid compounds, oxadiazole metal chelates, triazoles, sexithiophene derivatives, pyrazine, and styrylanthracene derivatives. The hole transporting layer can include an organic chromophore. The organic chromophore can be a phenyl amine, such as, for example, N,N'-diphenyl-N,N'-bis(3-methylphenyl)-(1,1'-biphenyl)-4,4'-diamine (TPD). The HTL can include a polyaniline, a polypyrrole, a poly(phenylene vinylene), copper phthalocyanine, an aromatic tertiary amine or polynuclear aromatic tertiary amine, a 4,4'-bis(9-carbazolyl)-1,1'-biphenyl compound, or an N,N,N',N'-tetraarylbenzidine.

[0033] The layers can be deposited on a surface of one of the electrodes by spin coating, dip coating, vapor deposition, or other thin film deposition methods. See, for example, M. C. Schlamp, et al., *J. Appl. Phys.*, 82, 5837-5842, (1997); V. Santhanam, et al., *Langmuir*, 19, 7881-7887, (2003); and X. Lin, et al., *J. Phys. Chem. B*, 105, 3353-3357, (2001), each of which is incorporated by reference in its entirety. The second electrode can be sandwiched, sputtered, or evaporated onto the exposed surface of the solid layer. One or both of the electrodes can be patterned. The electrodes of the device can be connected to a voltage source by electrically conductive pathways. Upon application of the voltage, light is generated from the device.

[0034] Contact printing provides a method for applying a material to a predefined region on a substrate. See, for example, A. Kumar and G. Whitesides, *Applied Physics Letters*, 63, 2002-2004, (1993); and V. Santhanam and R. P. Andres, *Nano Letters*, 4, 41-44, (2004), each of which is incorporated by reference in its entirety. The predefined region is a region on the substrate where the material is selectively applied. The material and substrate can be chosen such that the material remains substantially entirely within the predetermined area. By selecting a predefined region that forms a pattern, material can be applied to the substrate such that the material forms a pattern. The pattern can be a regular pattern (such as an array, or a series of lines), or an irregular pattern. Once a pattern of material is formed on the substrate, the substrate can have a region including the material (the predefined region) and a region substantially free of material. In some circumstances, the material forms a mono-

layer on the substrate. The predefined region can be a discontinuous region. In other words, when the material is applied to the predefined region of the substrate, locations including the material can be separated by other locations that are substantially free of the material.

[0035] In general, contact printing begins by forming a mold. The mold has a surface which can include a pattern of elevations and depressions. A stamp is formed with a complementary pattern of elevations and depressions, for example by coating the patterned surface of the mold with a liquid polymer precursor that is cured while in contact with the mold surface. A stamp having a pattern of elevations and depressions is a textured stamp. The stamp can be a featureless stamp, or in other words, substantially free of elevations or depressions. A featureless stamp can be made using a featureless mold. The stamp can be made of an elastomeric material, such as, for example, a poly(dimethylsiloxane).

[0036] The stamp can be inked; that is, the stamp is contacted with a material which is to be deposited on a substrate. The material becomes reversibly adhered to the stamp. The ink can be applied selectively or non-selectively to the stamp. For example, the ink can be applied non-selectively by spin casting the material on the ink, thereby contacting all regions of the stamp with the ink. Ink jet printing can be used, for example, to apply ink selectively to the stamp. A selective application of ink can be used to form a pattern of ink on the stamp. The pattern of ink on the stamp can match a pattern of elevations and depressions on the stamp, or be independent of a pattern of elevations and depressions on the stamp. The ink can form a pattern on the stamp when the stamp is featureless. Ink jet printing can also be used to ink a single stamp with more than one material to be printed. In this way, a single stamping step can apply more than one material to a substrate. Each material on a stamp can form its own pattern on the stamp.

[0037] To transfer the material to the substrate, the inked stamp is contacted with the substrate. Pressure can be applied to the stamp or substrate to facilitate the transfer of material. When the stamp is a textured stamp, the elevated regions of the stamp can contact the substrate while the depressed regions of the stamp can be separated from the substrate. Where the inked stamp contacts the substrate, the ink material (or at least a portion thereof) is transferred from the stamp to the substrate. When the stamp is non-selectively inked, the pattern of elevations and depressions is transferred from the stamp to the substrate as regions including the material and free of the material on the substrate. A selectively inked featureless stamp will create a pattern on the substrate that matches the pattern of ink on the stamp. If a textured stamp is selectively inked, material will be transferred to the substrate only where an elevation has been inked.

[0038] Contact printing and related techniques are described in, for example, U.S. Pat. Nos. 5,512,131; 6,180,239; and 6,518,168, each of which is incorporated by reference in its entirety.

[0039] FIG. 2 depicts a flow chart outlining the basic steps in the contact printing process. First, a silicon master is made using standard semiconductor processing techniques which define a pattern on the silicon surface, for example a pattern of elevations and depressions (alternatively, for a non-

patterned deposition, a blank Si master can be used). Poly dimethyl siloxane (PDMS, for example Sylgard 184) precursors are then mixed, degassed, poured onto the master, and degassed again, and allowed to cure at room temperature (or above room temperature, for faster cure times) (step 1). The PDMS stamp, having a surface including the pattern of the silicon master, is then freed from the master, and cut into the desired shape and size. This stamp can then optionally be modified with a surface chemistry layer, selected to readily adhere and release the ink as needed (step 2). The surface chemistry layer can be both a barrier to stamp swelling by the ink solvent, and an adhesion/release layer for the ink. Aromatic organic polymers, deposited by chemical vapor deposition, can be used as a surface chemistry layer. See, for example, S. Coe-Sullivan, et al., *Advanced Functional Materials*, 15, 1117-1124 (2005), which is incorporated by reference in its entirety. Application of the surface chemistry layer by chemical vapor deposition can result in a conformal coating of the shaped stamp. The surface chemistry layer can be chosen to be compatible with spreading of chloroform-solvated inks. Ink is then applied to the stamp (step 3). The inked stamp can then be contacted to a substrate, and gentle pressure applied for 30 seconds to transfer the ink to the new substrate (step 4).

[0040] The ink can include a nanomaterial. A nanomaterial can be any material having a dimension smaller than 100 nm. The nanomaterial can be, for example, a nanoparticle (e.g., a silica nanoparticle, a titania nanoparticle, or a metal nanoparticle), a semiconductor nanocrystal, a nanotube (such as a single walled or multi-walled carbon nanotube), a nanowire, a nanorod, or a polymer. The ink can include a sol-gel, such as a metal oxide sol-gel.

[0041] For example, the surface chemistry layer can be a chemical vapor deposited Parylene-C layer. The Parylene-C layer can be, for example, 0.1 to 2 μm thick, depending on the pattern to be reproduced (step 2). This stamp is then inked by applying (e.g., spin-casting or ink jet printing) of a solution of a material, such as semiconductor nanocrystals (step 3). A solution of semiconductor nanocrystals can have, for example, a concentration of 1-10 mg/mL of semiconductor nanocrystals dispersed in chloroform. The concentration can be varied depending on desired outcome. The inked stamp can then be contacted to a substrate, and gentle pressure applied for 30 seconds to transfer the ink (e.g., a semiconductor nanocrystal monolayer) completely to the new substrate (step 4). FIGS. 2A and 2B depict the preparation of an ITO coated glass substrate. A hole transport and/or a hole injection layer (HTL and HIL, respectively) including organic semiconductor is thermally evaporated onto the ITO substrate. The patterned semiconductor nanocrystal monolayer is transferred to this HTL layer, and the rest of the device (e.g., electron transport layer (ETL), electron injection layer (EIL), and metal contacts) can then be added (step 5).

[0042] In some cases, multiple layers of materials can be deposited simultaneously. For example, an stamp can be inked with an unpatterned layer of a first material, such as a metal or a metal oxide. A patterned layer of a second material is deposited over the first material. The second material can include a nanomaterial, e.g., semiconductor nanocrystals. When the stamp is contacted to a substrate, both the unpatterned and patterned layers are transferred from the stamp to the substrate.

[0043] Referring to FIG. 3, an ink jet printing system 10 includes ink jet print heads 20, 30 and 40. Each print head can deliver a different ink. The ink jet print heads can be, for example, piezoelectric or thermal ink jet print heads. In FIG. 3A, print heads 20, 30 and 40 deliver ink droplets 22, 32, and 42, respectively, to printing surface 55 of stamp 50. In FIG. 3, the stamp is a featureless stamp. FIG. 3B shows ink spots 24, 34, and 44 formed by droplets 22, 32, and 42 on surface 55. This inked stamp can be used to transfer the ink in spots 24, 34 and 44 to a substrate. FIG. 3C shows inked stamp 50 in contact with substrate 60. Specifically, stamp 50 is oriented such that printing surface 55 contacts a surface 65 of substrate 60. Pressure (indicated by arrows) can be applied to closely associate printing surface 55 with surface 65. FIG. 3D shows the transferred ink spots 26, 36, 46 after transfer from the stamp 50 to surface 65 of substrate 60. The arrangement of spots 26, 36, 46 determined in the ink jet printing step is preserved on surface 65.

[0044] As shown in FIG. 4A, stamp 50 can be a textured stamp, for example having elevations 70, 80 and 90 of printing surface 55. Ink jet printing can form ink spots 72, 82 and 92 on the elevations. The size of the ink spot can be less than, equal to, or greater than the size of the elevation. When the ink spot is larger than the elevation, ink can be transferred to the substrate only where the elevation contacts the substrate, resulting in an ink spot on the substrate equal in size to the elevation, and smaller than the ink spot applied to the stamp. The ink spots can include the same or different materials. Ink jet printing different inks on elevated regions of a stamp can be useful for ensuring that once transferred to a substrate, the ink spots do not overlap or bleed into one another.

[0045] FIG. 5 depicts a system for forming a pattern of a material on a substrate. Ink jet print head 100 delivers ink droplets 110 which form ink spots 120 on printing surface 130 of stamp 135. Stamp 135 can be, for example, a cylindrical stamp mounted on the circumference of rotating drum 140. Stamp 135 (which can be a textured or featureless stamp) contacts surface 155 of substrate 150 at contact point 160. As the rotating drum 140 turns (indicated by curved arrow), ink spots 120 reach contact point 160, where they are transferred to surface 155 of substrate 150 (moving in the direction indicated by the straight arrow), forming transferred ink spots 170. Drum 140 and stamp 135 can be configured to apply pressure to substrate 150 at contact point 160, in order facilitate transfer of ink spots 120. The system can be operated continuously.

[0046] When the electron and hole localize on a nanocrystal, emission can occur at an emission wavelength. The emission has a frequency that corresponds to the band gap of the quantum confined semiconductor material. The band gap is a function of the size of the nanocrystal. Nanocrystals having small diameters can have properties intermediate between molecular and bulk forms of matter. For example, nanocrystals based on semiconductor materials having small diameters can exhibit quantum confinement of both the electron and hole in all three dimensions, which leads to an increase in the effective band gap of the material with decreasing crystallite size. Consequently, both the optical absorption and emission of nanocrystals shift to the blue, or to higher energies, as the size of the crystallites decreases.

[0047] The emission from the nanocrystal can be a narrow Gaussian emission band that can be tuned through the

complete wavelength range of the ultraviolet, visible, or infrared regions of the spectrum by varying the size of the nanocrystal, the composition of the nanocrystal, or both. For example, CdSe can be tuned in the visible region and InAs can be tuned in the infrared region. The narrow size distribution of a population of nanocrystals can result in emission of light in a narrow spectral range. The population can be monodisperse and can exhibit less than a 15% rms deviation in diameter of the nanocrystals, preferably less than 10%, more preferably less than 5%. Spectral emissions in a narrow range of no greater than about 75 nm, preferably 60 nm, more preferably 40 nm, and most preferably 30 nm full width at half max (FWHM) can be observed. The breadth of the emission decreases as the dispersity of nanocrystal diameters decreases. Semiconductor nanocrystals can have high emission quantum efficiencies such as greater than 10%, 20%, 30%, 40%, 50%, 60%, 70%, or 80%.

[0048] The semiconductor forming the nanocrystals can include Group II-VI compounds, Group II-V compounds, Group III-VI compounds, Group III-V compounds, Group IV-VI compounds, Group I-III-VI compounds, Group II-IV-VI compounds, or Group II-IV-V compounds, for example, ZnS, ZnSe, ZnTe, CdS, CdSe, CdTe, HgS, HgSe, HgTe, AlN, AlP, AlAs, AlSb, GaN, GaP, GaAs, GaSb, GaSe, InN, InP, InAs, InSb, TiN, TiP, TiAs, TiSb, PbS, PbSe, PbTe, or mixtures thereof.

[0049] Methods of preparing monodisperse semiconductor nanocrystals include pyrolysis of organometallic reagents, such as dimethyl cadmium, injected into a hot, coordinating solvent. This permits discrete nucleation and results in the controlled growth of macroscopic quantities of nanocrystals. Preparation and manipulation of nanocrystals are described, for example, in U.S. Pat. Nos. 6,322,901 and 6,576,291, and U.S. patent application No. 60/550,314, each of which is incorporated by reference in its entirety. The method of manufacturing a nanocrystal is a colloidal growth process. Colloidal growth occurs by rapidly injecting an M donor and an X donor into a hot coordinating solvent. The injection produces a nucleus that can be grown in a controlled manner to form a nanocrystal. The reaction mixture can be gently heated to grow and anneal the nanocrystal. Both the average size and the size distribution of the nanocrystals in a sample are dependent on the growth temperature. The growth temperature necessary to maintain steady growth increases with increasing average crystal size. The nanocrystal is a member of a population of nanocrystals. As a result of the discrete nucleation and controlled growth, the population of nanocrystals obtained has a narrow, monodisperse distribution of diameters. The monodisperse distribution of diameters can also be referred to as a size. The process of controlled growth and annealing of the nanocrystals in the coordinating solvent that follows nucleation can also result in uniform surface derivatization and regular core structures. As the size distribution sharpens, the temperature can be raised to maintain steady growth. By adding more M donor or X donor, the growth period can be shortened.

[0050] The M donor can be an inorganic compound, an organometallic compound, or elemental metal. M is cadmium, zinc, magnesium, mercury, aluminum, gallium, indium or thallium. The X donor is a compound capable of reacting with the M donor to form a material with the general formula MX. Typically, the X donor is a chalcogenide.

genide donor or a pnictide donor, such as a phosphine chalcogenide, a bis(silyl) chalcogenide, dioxygen, an ammonium salt, or a tris(silyl) pnictide. Suitable X donors include dioxygen, bis(trimethylsilyl) selenide ((TMS)₂Se), trialkyl phosphine selenides such as (tri-n-octylphosphine) selenide (TOPSe) or (tri-n-butylphosphine) selenide (TBPSe), trialkyl phosphine tellurides such as (tri-n-octylphosphine) telluride (TOPTe) or hexapropylphosphorustriamide telluride (HPPTe), bis(trimethylsilyl)telluride ((TMS)₂Te), bis(trimethylsilyl)sulfide ((TMS)₂S), a trialkyl phosphine sulfide such as (tri-n-octylphosphine) sulfide (TOPS), an ammonium salt such as an ammonium halide (e.g., NH₄Cl), tris(trimethylsilyl) phosphide ((TMS)₃P), tris(trimethylsilyl) arsenide ((TMS)₃As), or tris(trimethylsilyl) antimonide ((TMS)₃Sb). In certain embodiments, the M donor and the X donor can be moieties within the same molecule.

[0051] A coordinating solvent can help control the growth of the nanocrystal. The coordinating solvent is a compound having a donor lone pair that, for example, has a lone electron pair available to coordinate to a surface of the growing nanocrystal. Solvent coordination can stabilize the growing nanocrystal. Typical coordinating solvents include alkyl phosphines, alkyl phosphine oxides, alkyl phosphonic acids, or alkyl phosphinic acids, however, other coordinating solvents, such as pyridines, furans, and amines may also be suitable for the nanocrystal production. Examples of suitable coordinating solvents include pyridine, tri-n-octyl phosphine (TOP), tri-n-octyl phosphine oxide (TOPO) and tris-hydroxypropylphosphine (THPP). Technical grade TOPO can be used.

[0052] Size distribution during the growth stage of the reaction can be estimated by monitoring the absorption line widths of the particles. Modification of the reaction temperature in response to changes in the absorption spectrum of the particles allows the maintenance of a sharp particle size distribution during growth. Reactants can be added to the nucleation solution during crystal growth to grow larger crystals. By stopping growth at a particular nanocrystal average diameter and choosing the proper composition of the semiconducting material, the emission spectra of the nanocrystals can be tuned continuously over the wavelength range of 300 nm to 5 microns, or from 400 nm to 800 nm for CdSe and CdTe. The nanocrystal has a diameter of less than 150 Å. A population of nanocrystals has average diameters in the range of 15 Å to 125 Å.

[0053] The nanocrystal can be a member of a population of nanocrystals having a narrow size distribution. The nanocrystal can be a sphere, rod, disk, or other shape. The nanocrystal can include a core of a semiconductor material. The nanocrystal can include a core having the formula MX, where M is cadmium, zinc, magnesium, mercury, aluminum, gallium, indium, thallium, or mixtures thereof, and X is oxygen, sulfur, selenium, tellurium, nitrogen, phosphorus, arsenic, antimony, or mixtures thereof.

[0054] The core can have an overcoating on a surface of the core. The overcoating can be a semiconductor material having a composition different from the composition of the core. The overcoat of a semiconductor material on a surface of the nanocrystal can include a Group II-VI compounds, Group II-V compounds, Group III-VI compounds, Group III-V compounds, Group IV-VI compounds, Group I-III-VI compounds, Group II-IV-VI compounds, and Group II-IV-V

compounds, for example, ZnS, ZnSe, ZnTe, CdS, CdSe, CdTe, HgS, HgSe, HgTe, AlN, AlP, AlAs, AlSb, GaN, GaP, GaAs, GaSb, GaSe, InN, InP, InAs, InSb, TiN, TiP, TiAs, TiSb, PbS, PbSe, PbTe, or mixtures thereof. For example, ZnS, ZnSe or CdS overcoatings can be grown on CdSe or CdTe nanocrystals. An overcoating process is described, for example, in U.S. Pat. No. 6,322,901. By adjusting the temperature of the reaction mixture during overcoating and monitoring the absorption spectrum of the core, over coated materials having high emission quantum efficiencies and narrow size distributions can be obtained. The overcoating can be between 1 and 10 monolayers thick.

[0055] The particle size distribution can be further refined by size selective precipitation with a poor solvent for the nanocrystals, such as methanol/butanol as described in U.S. Pat. No. 6,322,901. For example, nanocrystals can be dispersed in a solution of 10% butanol in hexane. Methanol can be added dropwise to this stirring solution until opalescence persists. Separation of supernatant and flocculate by centrifugation produces a precipitate enriched with the largest crystallites in the sample. This procedure can be repeated until no further sharpening of the optical absorption spectrum is noted. Size-selective precipitation can be carried out in a variety of solvent/nonsolvent pairs, including pyridine/hexane and chloroform/methanol. The size-selected nanocrystal population can have no more than a 15% rms deviation from mean diameter, preferably 10% rms deviation or less, and more preferably 5% rms deviation or less.

[0056] The outer surface of the nanocrystal can include a layer of compounds derived from the coordinating solvent used during the growth process. The surface can be modified by repeated exposure to an excess of a competing coordinating group to form an overlayer. For example, a dispersion of the capped nanocrystal can be treated with a coordinating organic compound, such as pyridine, to produce crystallites which disperse readily in pyridine, methanol, and aromatics but no longer disperse in aliphatic solvents. Such a surface exchange process can be carried out with any compound capable of coordinating to or bonding with the outer surface of the nanocrystal, including, for example, phosphines, thiols, amines and phosphates. The nanocrystal can be exposed to short chain polymers which exhibit an affinity for the surface and which terminate in a moiety having an affinity for a suspension or dispersion medium. Such affinity improves the stability of the suspension and discourages flocculation of the nanocrystal. Nanocrystal outer layers are described in U.S. Pat. No. 6,251,303, which is incorporated by reference in its entirety.

[0057] More specifically, the coordinating ligand can have the formula:

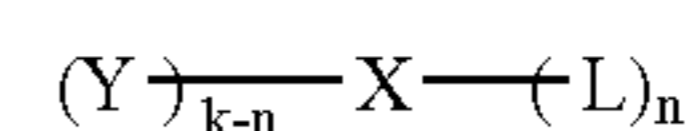

wherein k is 2, 3 or 5, and n is 1, 2, 3, 4 or 5 such that k-n is not less than zero; X is O, S, S=O, SO₂, Se, Se=O, N, N=O, P, P=O, As, or As=O; each of Y and L, independently, is aryl, heteroaryl, or a straight or branched C₂₋₁₂ hydrocarbon chain optionally containing at least one double bond, at least one triple bond, or at least one double bond and one triple bond. The hydrocarbon chain can be optionally

substituted with one or more C₁₋₄ alkyl, C₂₋₄ alkenyl, C₂₋₄ alkynyl, C₁₋₄ alkoxy, hydroxyl, halo, amino, nitro, cyano, C₃₋₅ cycloalkyl, 3-5 membered heterocycloalkyl, aryl, heteroaryl, C₁₋₄ alkylcarbonyloxy, C₁₋₄ alkylloxycarbonyl, C₁₋₄ alkylcarbonyl, or formyl. The hydrocarbon chain can also be optionally interrupted by —O—, —S—, —N(R^a)—, —N(R^a)—C(O)—O—, —O—C(O)—N(R^a)—, —N(R^a)—C(O)—N(R^b)—, —O—C(O)—O—, —P(R^a)—, or —P(O)(R^a)—. Each of R^a and R^b, independently, is hydrogen, alkyl, alkenyl, alkynyl, alkoxy, hydroxylalkyl, hydroxyl, or haloalkyl.

[0058] An aryl group is a substituted or unsubstituted cyclic aromatic group. Examples include phenyl, benzyl, naphthyl, tolyl, anthracyl, nitrophenyl, or halophenyl. A heteroaryl group is an aryl group with one or more heteroatoms in the ring, for instance furyl, pyridyl, pyrrolyl, phenanthryl.

[0059] A suitable coordinating ligand can be purchased commercially or prepared by ordinary synthetic organic techniques, for example, as described in J. March, *Advanced Organic Chemistry*, which is incorporated by reference in its entirety.

[0060] Transmission electron microscopy (TEM) can provide information about the size, shape, and distribution of the nanocrystal population. Powder X-ray diffraction (XRD) patterns can provide the most complete information regarding the type and quality of the crystal structure of the nanocrystals. Estimates of size are also possible since particle diameter is inversely related, via the X-ray coherence length, to the peak width. For example, the diameter of the nanocrystal can be measured directly by transmission electron microscopy or estimated from X-ray diffraction data using, for example, the Scherrer equation. It also can be estimated from the UV/Vis absorption spectrum.

[0061] The device can be made in a controlled (oxygen-free and moisture-free) environment, preventing the quenching of luminescent efficiency during the fabrication process. Other multilayer structures may be used to improve the device performance (see, for example, U.S. patent application Ser. Nos. 10/400,908 and 10/400,908, each of which is incorporated by reference in its entirety). A blocking layer, such as an electron blocking layer (EBL), a hole blocking layer (HBL) or a hole and electron blocking layer (eBL), can be introduced in the structure. A blocking layer can include 3-(4-biphenyl)-4-phenyl-5-tert-butylphenyl-1,2,4-triazole (TAZ), 3,4,5-triphenyl-1,2,4-triazole, 3,5-bis(4-tert-butylphenyl)-4-phenyl-1,2,4-triazole, bathocuproine (BCP), 4,4',4''-tris{N-(3-methylphenyl)-N-phenylamino}triphenylamine (m-MTDATA), polyethylene dioxythiophene (PEDOT), 1,3-bis(5-(4-diphenylamino)phenyl-1,3,4-oxadiazol-2-yl)benzene, 2-(4-biphenyl)-5-(4-tert-butylphenyl)-1,3,4-oxadiazole, 1,3-bis[5-(4-(1,1-dimethylethyl)phenyl)-1,3,4-oxadiazol-2-yl]benzene, 1,4-bis(5-(4-diphenylamino)phenyl-1,3,4-oxadiazol-2-yl)benzene, or 1,3,5-tris[5-(4-(1,1-dimethylethyl)phenyl)-1,3,4-oxadiazol-2-yl]benzene.

[0062] The performance of organic light emitting devices can be improved by increasing their efficiency, narrowing or broadening their emission spectra, or polarizing their emission. See, for example, Bulovic et al., *Semiconductors and Semimetals* 64, 255 (2000), Adachi et al., *Appl. Phys. Lett.* 78, 1622 (2001), Yamasaki et al., *Appl. Phys. Lett.* 76, 1243

(2000), Dirr et al., *Jpn. J. Appl. Phys.* 37, 1457 (1998), and D'Andrade et al., *MRS Fall Meeting*, BB6.2 (2001), each of which is incorporated herein by reference in its entirety. Nanocrystals can be included in efficient hybrid organic/inorganic light emitting devices.

[0063] The narrow FWHM of nanocrystal light emission can result in saturated color emission. This can lead to efficient nanocrystal-light emitting devices even in the red and blue parts of the visible spectrum, since in nanocrystal emitting devices no photons are lost to infrared and UV emission. The broadly tunable, saturated color emission over the entire visible spectrum of a single material system is unmatched by any class of organic chromophores (see, for example, Dabbousi et al., *J. Phys. Chem.* 101, 9463 (1997), which is incorporated by reference in its entirety). A monodisperse population of nanocrystals will emit light spanning a narrow range of wavelengths. A device including more than one size of nanocrystal can emit light in more than one narrow range of wavelengths. The color of emitted light perceived by a viewer can be controlled by selecting appropriate combinations of nanocrystal sizes and materials in the device. Furthermore, environmental stability of covalently bonded inorganic nanocrystals suggests that device lifetimes of hybrid organic/inorganic light emitting devices should match or exceed that of all-organic light emitting devices, when nanocrystals are used as luminescent centers. The degeneracy of the band edge energy levels of nanocrystals facilitates capture and radiative recombination of all possible excitons, whether generated by direct charge injection or energy transfer. The maximum theoretical nanocrystal-light emitting device efficiencies are therefore comparable to the unity efficiency of phosphorescent organic light emitting devices. The excited state lifetime (τ) of the nanocrystal is much shorter ($\tau \sim 10$ ns) than a typical phosphor ($\tau > 0.5$ μ s), enabling nanocrystal-light emitting devices to operate efficiently even at high current density.

[0064] Devices can be prepared that emit visible or infrared light. The size and material of a semiconductor nanocrystal can be selected such that the nanocrystal emits visible or infrared light of a selected wavelength. The wavelength can be between 300 and 2,500 nm or greater, for instance between 300 and 400 nm, between 400 and 700 nm, between 700 and 1100 nm, between 1100 and 2500 nm, or greater than 2500 nm.

[0065] Individual devices can be formed at multiple locations on a single substrate to form a display. The display can include devices that emit at different wavelengths. By patterning the substrate with arrays of different color-emitting materials, a display including pixels of different colors can be formed. In some applications, the substrate can include a backplane. The backplane includes active or passive electronics for controlling or switching power to individual pixels. Include a backplane can be useful for applications such as displays, sensors, or imagers. In particular, the backplane can be configured as an active matrix, passive matrix, fixed format, directly drive, or hybrid. The display can be configured for still images, moving images, or lighting. A lighting display can provide white light, monochrome light, or color-tunable light.

[0066] The surface relief at each step of the contact printing process was measured by atomic force microscopy (AFM). A PDMS stamp was cast on a planar (non-patterned)

master, forming a featureless stamp. The stamp was inked with semiconductor nanocrystals, and then the semiconductor nanocrystals were transferred to the organic semiconductor hole transporting layer. The semiconductor nanocrystals formed a sub-monolayer (i.e., a monolayer that does not cover all of the available area) that covered 30-40% of the surface area of the hole transporting layer. Islands of semiconductor nanocrystals which make up the sub-monolayer were visible in the AFM images, though the individual semiconductor nanocrystals were observable only when they are found isolated from other semiconductor nanocrystals. The total peak-to-peak height was less than 10 nm, indicating that the deposition was indeed only one monolayer thick (the semiconductor nanocrystals used in this experiment were 6-8 nm in diameter). Monolayers with film area coverages of greater than 90% were achieved by increasing the concentration of semiconductor nanocrystals in the original chloroform solution that was used to ink the stamp.

[0067] The contact printing of semiconductor nanocrystals was a dry process (i.e., did not require solvent) that did not introduce impurities into the device fabrication. All of the organic layers in the device were deposited under ultra-high vacuum conditions. The organic layers were exposed only once to a nitrogen environment for the deposition of the semiconductor nanocrystal layers. None of the organic semiconductor materials were exposed to solvent at any step of the device fabrication. The semiconductor nanocrystal deposition was followed by the successive deposition of a hole blocking layer (HBL) 3-(4-biphenyl)-4-phenyl-5-tert-butylphenyl-1, 2, 4-triazole (TAZ) and the ETL, tris-(8 hydroxyquinoline)aluminum (Alq₃), and finally an evaporated Mg:Ag/Ag cathode (50:1 Mg:Ag by weight).

[0068] The electroluminescence (EL) spectra of red-, green-, and blue-emitting devices were recorded, and digital photos taken of individual red, green, and blue devices. The external quantum efficiency and current-voltage curves were also measured.

[0069] Previous work on semiconductor nanocrystal light emitting devices employed N,N'-diphenyl-N,N'-bis(3-methylphenyl)-(1,1'-biphenyl)-4,4'-diamine (TPD) as the HTL, due to its good solubility in chloroform and chlorobenzene (which are solvent compatible with the semiconductor nanocrystals) compared to many other HTL candidates. The contact printing method does not require that the HTL/HIL material be solvent compatible with the semiconductor nanocrystal. Therefore, other HTL/HIL materials were explored, and the wide band gap organic semiconductor CBP was employed. The larger band gap CBP molecule produced far better color saturation in the devices. Color saturation refers to how pure a color appears to the human eye and is quantified in the Commission International d'Eclairage (CIE) chromaticity coordinates, calculated from the emission wavelength and bandwidth (full width at half maximum), which in turn can then be plotted on the CIE diagram.

[0070] The greater color saturation can be attributed to the larger downhill energy transfer process now available with the use of CBP, which results in decreased intensity of organic emission and increased intensity of semiconductor nanocrystal emission, leading in turn to a larger ratio between the semiconductor nanocrystal EL to organic EL.

[0071] The superior color saturation of the red and green semiconductor nanocrystal devices was represented by their position on the CIE diagram relative to the current High Definition Television (HDTV) standard color triangle. The CIE color coordinates of the blue device lie just inside the HDTV standard color triangle and was a result of a red tail seen in the EL spectrum of the blue device. This red tail can be the result of exiplex emission—in other words, a mixed state between the two large band gap HTL and HBL in our device structure. This exiplex emission was not seen in the red device, possibly because those energy states from the exiplex are Forster energy-transferred to the red-emitting semiconductor nanocrystals. The green device exhibited only a very small amount of this exiplex emission, probably due to the high degree of film coverage of the monolayer of green emitting semiconductor nanocrystals, which separates the HTL from the HBL and therefore their interaction, as well as the high PL quantum efficiency (40%) of the nanocrystals themselves, which contributes to the large nanocrystal EL intensity relative to the organic exiplex EL. Another contributing factor is that when the devices are run at high currents (~100 μ A) the exiplex emission peak shifts from ~620 nm to ~520 nm, which is right over the green nanocrystal emission peak and is either covered completely by the green nanocrystal emission or is Forster energy transferred to the green emitting nanocrystals. The blue devices will improve as the blue emitting semiconductor nanocrystal PL quantum efficiency increases (currently 20%). The external quantum efficiency (EQE) of the red, green, and blue semiconductor nanocrystal devices and demonstrates how the EQE of the devices scales with the PL quantum efficiency of the semiconductor nanocrystals. Currently the EQE of the red-emitting device was 1.2% using semiconductor nanocrystals having PL quantum efficiencies of 70% after processing and preparing for device use. The green-emitting nanocrystal devices had EQEs of 0.5% using semiconductor nanocrystals with PL quantum efficiencies of 40%. The blue EQE was 0.25% using semiconductor nanocrystals with PL quantum efficiencies of 20%. All three colors of nanocrystal devices had reproducible, stable current-voltage (IV) characteristics, with turn on voltages of 2-5 V and operating voltages of 8-12 V. Display brightness (100 cd/m²) was achieved at ~2 mA/cm² and ~10 V for all three colors of nanocrystal light emitting devices.

[0072] An area of green-emitting semiconductor nanocrystals was stamped next to an area of red-emitting semiconductor nanocrystals on the same 1 inch substrate. The three devices were turned on: adjacent red- and green-emitting devices as well as a device on an area where no semiconductor nanocrystals were stamped (i.e., an organic LED with the structure: ITO/CBP/TAZ/Alq₃/Mg:Ag/Ag).

[0073] The stamping technique can pattern sub-100 μ m features toward pixelation for nanocrystal light emitting displays. Green-emitting semiconductor nanocrystals were stamped over an area. Subsequently, red-emitting semiconductor nanocrystals were stamped down then on top of the green-emitting nanocrystals using a stamp that was patterned with posts. The posts were 5 μ m in height and 90 μ m in diameter. The device (0.5 mm in diameter) was turned on. Red circles on a field of green were visible within this device, the red circles corresponding to the sub-100 μ m patterned red-emitting semiconductor nanocrystals. A textured stamp can be used in contact printing to pattern

submicron features (see, e.g., U.S. Pat. Nos. 5,512,131; 6,180,239; and 6,518,168, each of which is incorporated by reference in its entirety).

[0074] A device was prepared with patterned lines of semiconductor nanocrystal monolayers. Such a technique can be employed in the fabrication of full color active matrix nanocrystal light emitting device displays. The stamp was patterned with lines 1 μm high and 100 μm in width. The result of stamping green-emitting nanocrystals using this patterned stamp and turning on an area of 1 mm by defining the device through the size of the cathode (Mg:Ag/Ag), was emission of the green nanocrystals, visible as lines of 100 μm wide, interspersed with the blue organic EL as a result of the absence of nanocrystals in the area between stamped lines.

[0075] The contact printing technique provides the ability to place different color emitting materials on the same substrate in a pattern, leading towards formation of pixels for full color display applications. The emitting materials can be, for example, semiconductor nanocrystals. Pixel dimensions for full color displays are typically on the order of 20-30 μm . Ink jet printing can form a pattern light emitting materials with feature sizes of 20 μm .

[0076] Red-, green-, and blue-emitting semiconductor nanocrystal-based light emitting devices are efficient, highly color saturated compared to organic LEDs and liquid crystal displays, and can be patterned towards pixelation for full color display applications by means of contact printing of single layers of nanocrystals.

[0077] Other embodiments are within the scope of the following claims.

What is claimed is:

1. A method of transferring a material to a substrate comprising:

depositing the material selectively on a surface of an applicator; and

contacting the surface of the applicator with the substrate.

2. The method of claim 1, wherein the material substantially free of solvent before contacting.

3. The method of claim 1, wherein depositing the material selectively includes forming a pattern including the material on the surface of the applicator.

4. The method of claim 3, wherein a feature of the pattern has a dimension of less than 1000 micrometers.

5. The method of claim 3, wherein a feature of the pattern has a dimension of less than 100 micrometers.

6. The method of claim 3, wherein a feature of the pattern has a dimension of less than 10 micrometers.

7. The method of claim 1, wherein forming the pattern includes ink jet printing the material.

8. The method of claim 1, wherein the surface of the applicator includes an elevation or a depression.

9. The method of claim 1, wherein the surface of the applicator is substantially free of elevations and depressions.

10. The method of claim 1, wherein the applicator includes an elastomeric material.

11. The method of claim 1, further comprising modifying the surface of the applicator before depositing the material selectively on the surface of the applicator.

12. The method of claim 11, wherein modifying the surface of the applicator includes contacting the surface of

the applicator with a composition selected to release at least a portion of the material from the applicator upon contact with a substrate.

13. The method of claim 12, wherein the composition includes an aromatic organic polymer.

14. The method of claim 1, further comprising depositing a second material selectively on the surface of the applicator.

15. The method of claim 14, wherein depositing the second material selectively includes forming a pattern on the surface of the applicator.

16. The method of claim 14, wherein depositing the second material includes ink jet printing.

17. The method of claim 1, wherein the surface of the applicator is in continuous contact with the substrate.

18. The method of claim 1, wherein the material includes a nanomaterial.

19. The method of claim 18, wherein the nanomaterial includes a semiconductor nanocrystal.

20. A method of transferring a plurality of materials to a substrate comprising:

depositing a first material selectively on a surface of an applicator;

depositing a second material selectively on the surface of the applicator; and

contacting the surface of the applicator with the substrate.

21. The method of claim 20, wherein the first material is substantially free of solvent before contacting.

22. The method of claim 21, wherein the second material is substantially free of solvent before contacting.

23. The method of claim 20, wherein depositing the first material includes forming a pattern on the surface of the applicator.

24. The method of claim 23, wherein depositing the second material includes forming a pattern on the surface of the applicator.

25. The method of claim 24, wherein depositing the first material includes ink jet printing.

26. The method of claim 25, wherein depositing the second material includes ink jet printing.

27. A system for transferring a material to a substrate comprising:

an ink jet print head including a reservoir, wherein the reservoir holds the material; and

an applicator having a surface arranged to receive the material from the ink jet print head.

28. The system of claim 27, further comprising a substrate arranged to contact the surface of the applicator.

29. The system of claim 28, wherein the surface of the applicator is configured to be in continuous contact with the substrate.

30. The system of claim 28, wherein the applicator is configured to move the surface of the applicator with respect to the ink jet print head.

31. The system of claim 28, wherein the applicator is mounted on a drum, the drum being configured to rotate.

32. The system of claim 31, wherein the surface of the applicator is configured to roll on the substrate.

33. The system of claim 27, wherein the surface of the applicator includes an elevation or a depression.

34. The system of claim 27, wherein the surface of the applicator is substantially free of elevations and depressions.

35. A method of making a light emitting device, comprising:

ink jet printing a material on a surface of an applicator;
and

contacting the surface of the applicator with a substrate.

36. The method of claim 35, wherein ink jet printing the material includes forming a pattern on the surface of the applicator.

37. The method of claim 35, wherein the material includes a light emitting material.

38. The method of claim 37, wherein the light emitting material includes a semiconductor nanocrystal.

39. The method of claim 35, wherein the substrate includes an electrode, a hole transport material, an electron

transport material, a hole injection material, an electron injection material, or a combination thereof.

40. A device for applying a material comprising an applicator and a material forming a pattern on a surface of the applicator.

41. The device of claim 40, wherein the surface of the applicator includes an elevation or a depression.

42. The device of claim 40, wherein in the surface of the applicator is substantially free of elevations or depressions.

43. The device of claim 40, wherein the applicator includes an elastomeric material.

44. The device of claim 40, further comprising a second material forming a pattern on the surface of an applicator.

* * * * *