



US 20060180240A1

(19) **United States**

(12) **Patent Application Publication**
Niedzwiechi et al.

(10) **Pub. No.: US 2006/0180240 A1**

(43) **Pub. Date: Aug. 17, 2006**

(54) **TRANSPORTABLE HYDROGEN REFUELING STATION**

(76) Inventors: **Alan Niedzwiechi**, Newport Beach, CA (US); **Andy Abele**, San Clemente, CA (US)

Correspondence Address:
GREENBERG TRAUIG LLP
2450 COLORADO AVENUE, SUITE 400E
SANTA MONICA, CA 90404 (US)

(21) Appl. No.: **10/543,123**

(22) PCT Filed: **Jan. 21, 2004**

(86) PCT No.: **PCT/US04/01634**

(30) **Foreign Application Priority Data**

Jan. 24, 2003 (US)..... 10/350583

Publication Classification

(51) **Int. Cl.**
B65B 1/04 (2006.01)

(52) **U.S. Cl.** **141/231; 141/82**

(57) **ABSTRACT**

A portable hydrogen refueling stations which can dispense gaseous hydrogen from one or more internal high pressure tanks. The refueling station can be refilled with a lower pressure hydrogen gas feed and then compressed for storage within a refueling station.

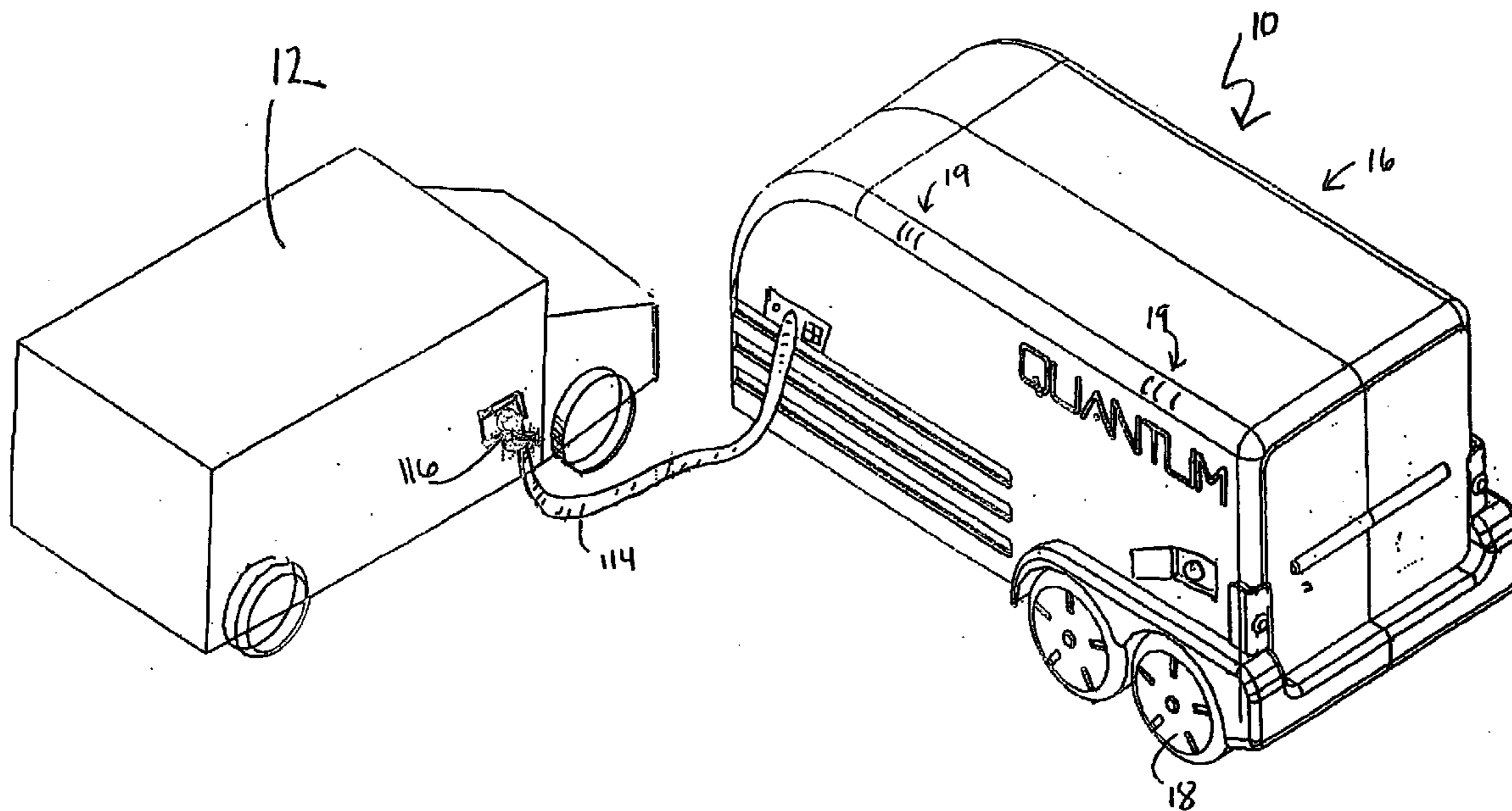

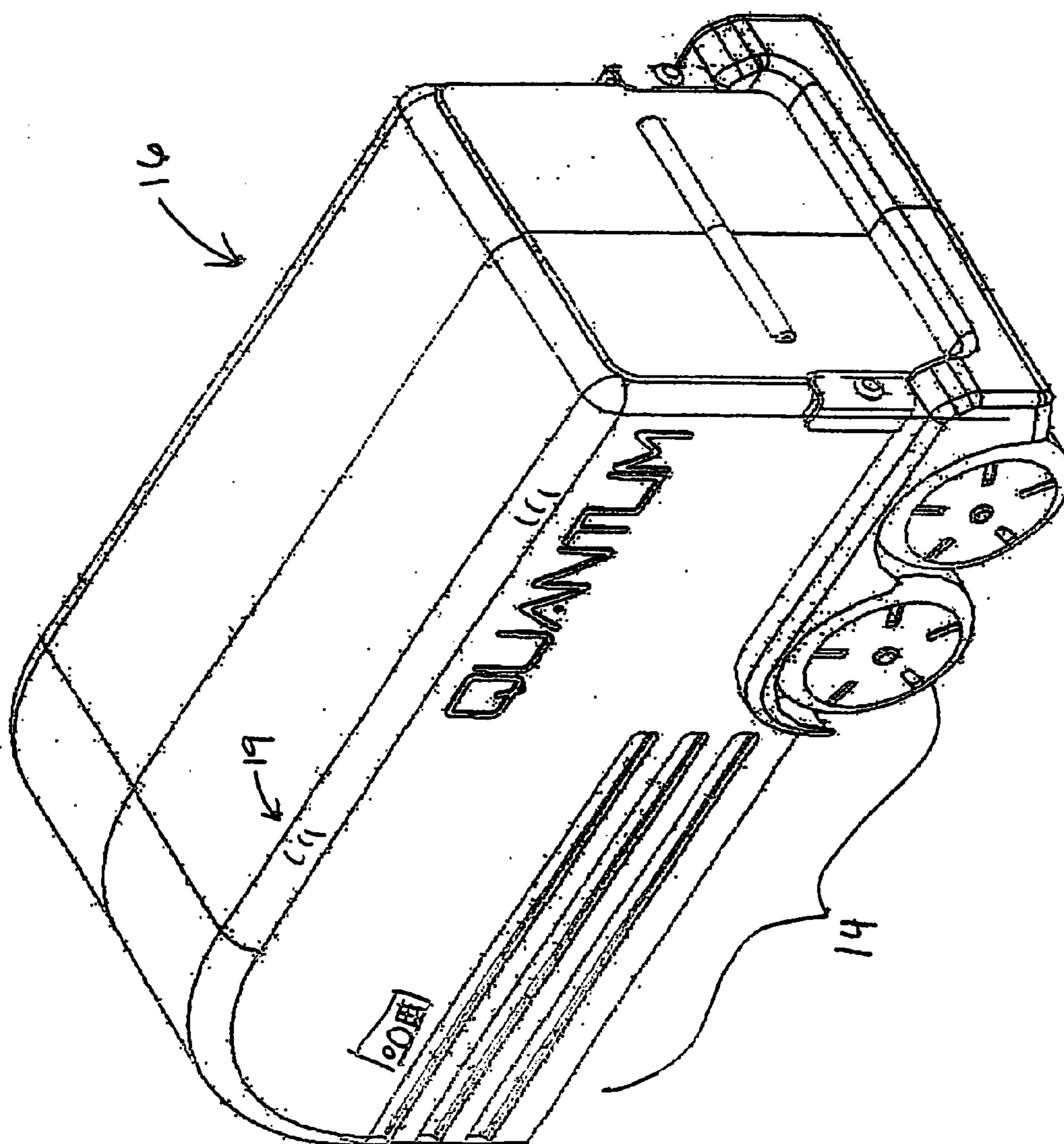

Fig. 1A

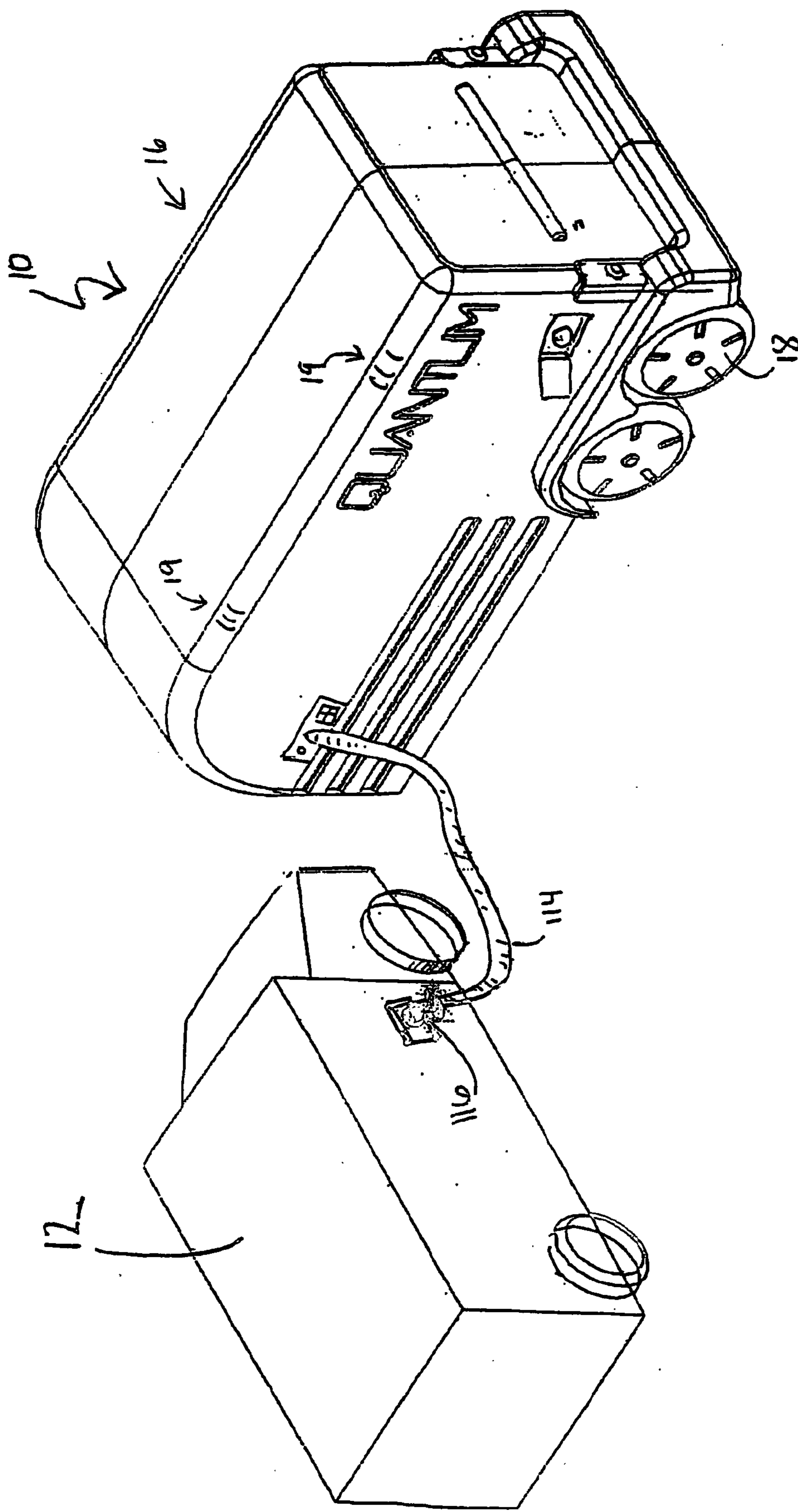

Fig 1B

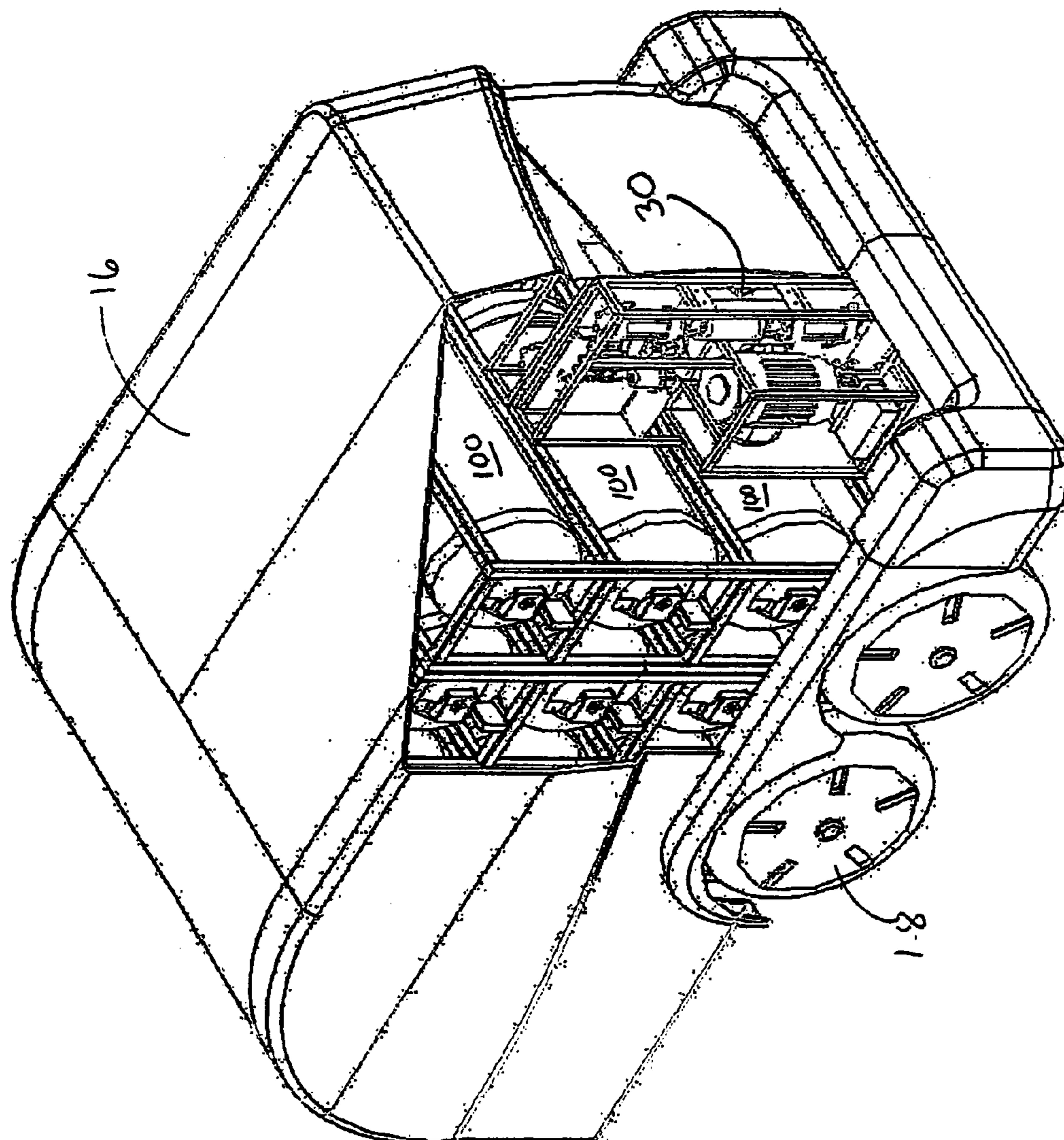

Fig 2A

Specifications	Option A	Option B
Hydrogen Storage	40 kg	80 kg
Storage Method	2 TriPacs™ (1,500 L)	4 TriPacs™ (3,000 L)
Overall Length	15 feet	17 feet
Curb Weight of HyHauler™	4,000 lbs.	5,500 lbs.
Power Requirement (US Grid)	10 kW (208 V, 3 Phase, 30 A or 240 V, 1 Phase, 50 A)	10 kW (208 V, 3 Phase, 30 A or 240 V, 1 Phase, 50 A)
Number of vehicles consecutively filled at 2 kg/vehicle (5,000 psi)	10-11	25-26
Number of vehicles consecutively filled at 5 kg/vehicle (5,000 psi)	3-4	9-10
Number of vehicles consecutively filled at 3 kg/vehicle (10,000 psi)	5-6	15-16
Time to recharge HyHauler™*	20 kg in 2-15 hrs.	40 kg in 3-24 hrs.

* Depending on source pressure and method of fill (i.e., cascade vs. compression only)

Fig. 2B

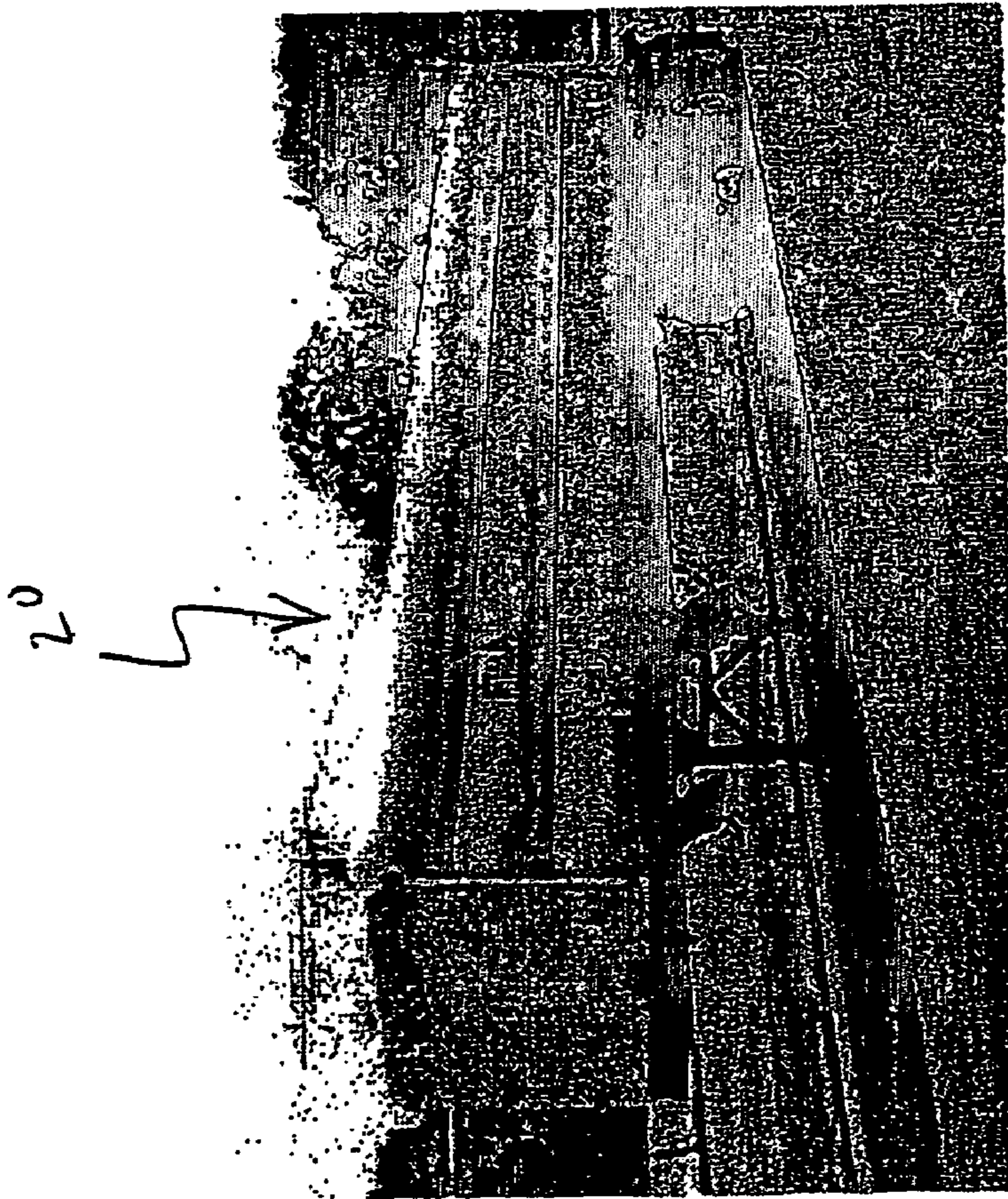

Fig. 3A

Number of Tubes	10-Tube
Hydrogen capacity	137,580 scf (717 lb)
Height	10 ft. 6 in.
Chassis & Tube Weight (3AAX)	60,000 lbs.
Overall Length	44 ft. 0 in.
Overall Width	8 ft. 0 in.
Chassis Weight	10,000 lbs.
Tube Diameter	22 in.
Tube Length (3AAX)	36 ft. 0 in.
Tube Specification	DOT 3AAX-2400
Avg. Tube Weight (3AAX)	5,000 lbs. Heavy Wall
Tube Nominal Water Volume (3AAX)	81.6 cf Heavy Wall
Avg. Operating Pressure (3AAX)	2,706 psig Heavy Wall

Fig 3B

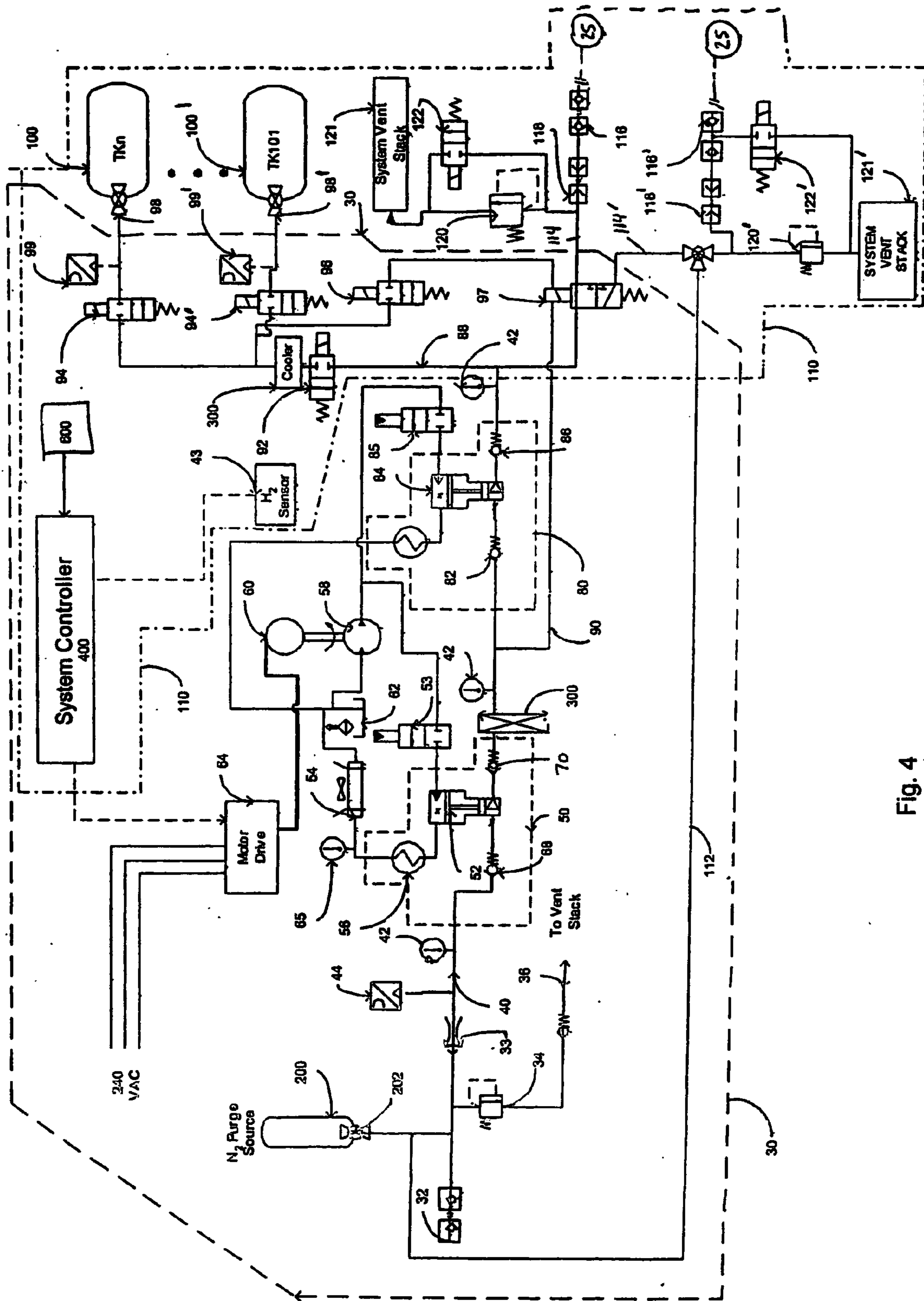

Fig. 4

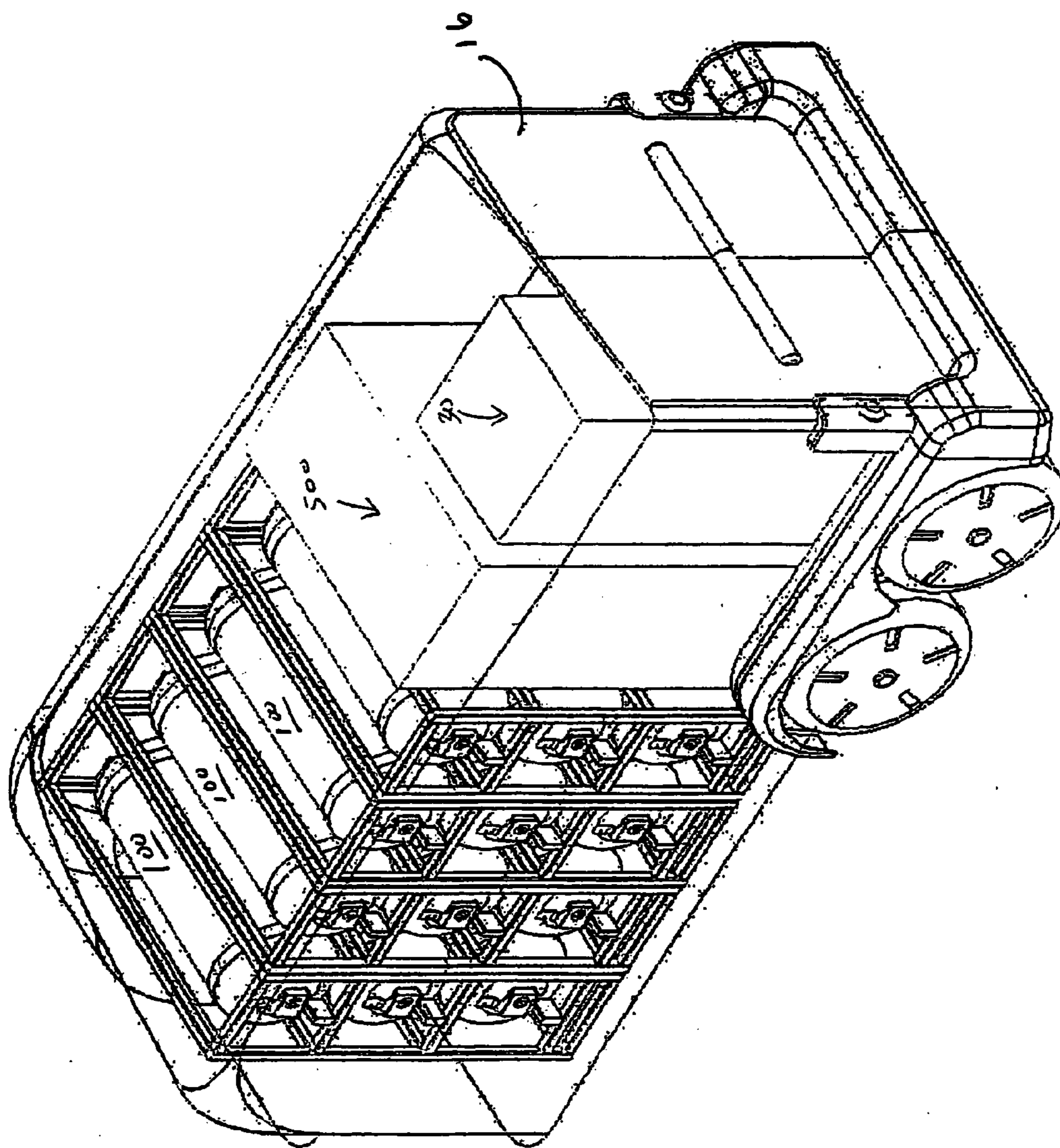

Fig. 5A

Specifications	Option C	Option D
Hydrogen Storage	40 kg	80 kg
Storage Method	2 TriPacs™	4 TriPacs™
Overall Length	16 feet	20 feet
Curb Weight of HyHauler Plus™	7,000 lbs.	9,200 lbs.
Power Requirement (US Grid)	10 kW compressor, 50 kW electrolyzer (480 V, 3 Phase, 80 kVA)	10 kW compressor, 50 kW electrolyzer (480 V, 3 Phase, 80 kVA)
Number of vehicles consecutively filled at 2 kg/vehicle (5,000 psi)	10-11	25-26
Number of vehicles consecutively filled at 5 kg/vehicle (5,000 psi)	3-4	9-10
Number of vehicles consecutively filled at 3 kg/vehicle (10,000 psi)	5-6	15-16
On-board H ₂ production rate	1 kg/hr.	1 kg/hr.
Temperature Range (Electrolyzer)	36 to 104°F	36 to 104°F

Fig 5B

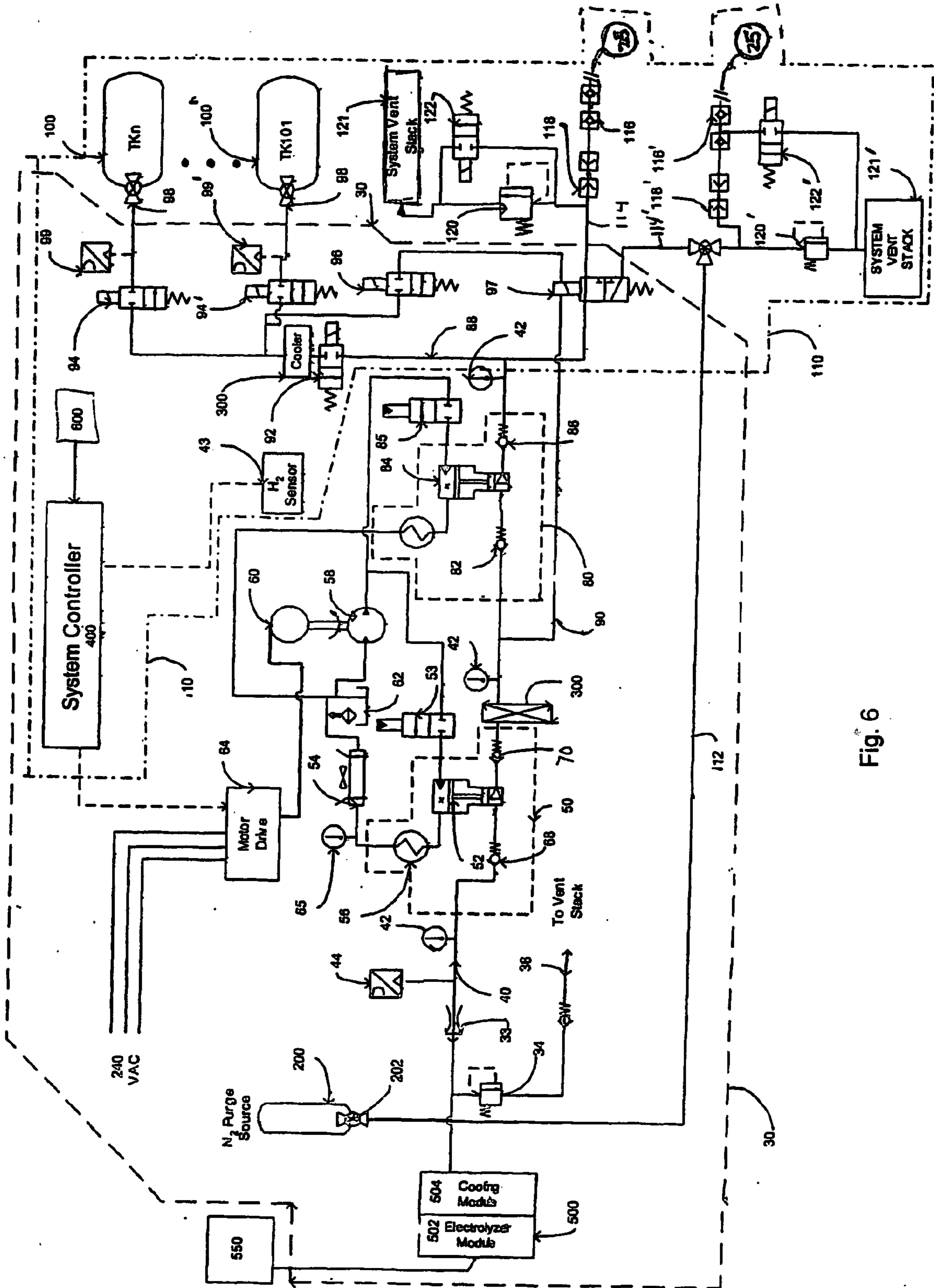

Fig. 6

TRANSPORTABLE HYDROGEN REFUELING STATION

FIELD OF THE INVENTION

[0001] This invention relates to a rechargeable device for storing and, when desired, releasing hydrogen. Among other applications, the device can be used in the energy generation or transportation industries.

BACKGROUND OF THE INVENTION

[0002] A hydrogen economy has become a National vision. "Hydrogen has the potential to solve two major energy challenges that confront America today: reducing dependence on petroleum imports and reducing pollution and greenhouse gas emissions. There is general agreement that hydrogen could play an increasingly important role in America's energy future. Hydrogen is an energy carrier that provides a future solution for America." *A National Vision of America's Transition to a Hydrogen Economy to 2030 and Beyond, based on results of the National Hydrogen Vision Meeting, Washington, D.C., Nov. 15-16, 2001 United States Department of Energy February 2002.*

[0003] For mobile hydrogen powered systems, i.e., fuel cell powered electric vehicles, hydrogen must be obtainable.

[0004] In U.S. Pat. No. 6,305,442, issued to Ovshinsky, a hydrogen infrastructure system is proposed. It teaches hydrogen bound to a metal alloy hydride. Release and storage of hydrogen bound to the hydride is a process which requires energy. Ovshinsky states that a major drawback of hydrogen as a fuel in mobile uses, such as powering of vehicles, is the lack of an acceptable lightweight hydrogen storage medium. Ovshinsky identifies hydrogen vessels as heavy, and having a "very great" explosion/fire hazard. Further, Ovshinsky identifies pressurized tankers as an unacceptable medium for transporting all but smaller quantities of hydrogen due to susceptibility to rupturing and explosion.

[0005] Accordingly, a hydrogen storage medium without necessitating the use of hydrides that is relatively lightweight and safe would be desirable.

[0006] A hydrogen replenishment system is taught in U.S. Pat. No. 6,432,283 issued to Fairlie et al. Fairlie teaches an electrolytic cell which produces oxygen gas during gaseous hydrogen production. The Fairlie system vents gaseous oxygen during the dispensing of hydrogen creating the explosive risk of hydrogen-oxygen mixtures. Accordingly, it would be desirable to have a refueling system wherein gaseous oxygen is not produced when the system is dispensing hydrogen thereby avoiding possible mixing of gaseous hydrogen and gaseous oxygen.

[0007] Additionally, hydrogen gas produced from the electrolytic cell described by Fairlie et. al is produced at an elevated temperature. Fairlie et al teaches away from the use of hydrogen storage tanks identifying them as a "potential safety risk" and teaches the simultaneous generation and dispensing of hydrogen. It is a well established principal of physics that the density of hydrogen gas is inverse to the temperature. In-fact, Fairlie notes that there is a problem of obtaining a false value of a high pressure fill (full tank) if the filling is too rapid due to temperature increase within the tank. At a constant pressure, the greater the temperature of the gaseous hydrogen, the lower the density of the gaseous

hydrogen thus creating a false value. Fairlie's temperature management solution is to wait for the external vessel to cool down by modulating the rate of fill.

[0008] Achieving a full fill, as noted by Fairlie, is particularly applicable to hydrogen fueled, fuel cell powered vehicles. The operating range (distance) a fuel cell powered vehicle can potentially travel is related to the quantity of hydrogen on board. A second variable equally applicable to promoting the operation of fuel cell powered vehicles is that sufficient quantity of hydrogen to support a preselected operating range is dispensed in a time frame which is within the "convenience expectations" of an end user. It is therefore desirable to have a hydrogen refueling station which manages the temperature of the gaseous hydrogen to minimize reductions in rate of fill.

[0009] Trailers transporting pressurized cylinders of gas are known in the art. Large semi-tanker/trailers for transporting gaseous fuels are also known in the art. Semi-tankers are not a convenient method for providing transportable hydrogen for refueling. Specifically, the use of a semi-tanker requires a specialized driver's license and due to weight and size restrictions, a semi-tanker may be limited to use on some roadways and may have limited access to some locations. A small trailer suitable for towing by a passenger vehicle which can transport upwards of 35 kg of hydrogen would solve many of the limitations of a semi-tanker.

SUMMARY OF INVENTION

[0010] A refillable hydrogen refueling station within an enclosure that can dispense upwards of 35 kg of hydrogen is taught. Gaseous hydrogen is stored at high pressure without the use of heavy tanks, hydrides or metal alloys. The refueling station within the enclosed one can be trailer supported. The trailer supported enclosure or the refueling station within an enclosed trailer can be towed by a passenger vehicle.

[0011] The energy density of a system for transporting hydrogen could be measured as grams/liter of stored gas as done by Ovshinsky in the U.S. Pat. No. 6,305,442 patent, however, such a measurement can be misleading when transportability of the hydrogen is a factor. For transportable hydrogen, a useful measure of energy density is grams of hydrogen per pound (gms/lb) of the gross weight of the transportable system.

[0012] The hydrogen refueling station accepts a hydrogen feed stock, increases the pressure of the hydrogen up to a desired pressure, and stores the hydrogen in one or more tanks for later dispensing. Distribution of the hydrogen is through a reversible connector that can dispense the hydrogen from the tanks to a receiving tank or apparatus.

[0013] In one embodiment, the hydrogen refueling station is self-refilling. It has a hydrogen producing subsystem which can also refill the tanks within the refueling station's hydrogen storage subsystem. The self-refilling function is provided by a hydrogen generating device such as an electrolyzer or electrolytic cell.

[0014] To reduce the risk of the gaseous oxygen, produced as a by-product of hydrogen generation, from mixing with gaseous hydrogen the hydrogen refueling station can be operated to produce and store hydrogen in the storage tanks at a time remote and distinct from the dispensing of the

hydrogen. Connections from the hydrogen producing subsystem to the hydrogen storage tanks are fixed and easily monitored for leaks as opposed to the temporary connections made by the reversible connector.

[0015] Common to the embodiments described herein is temperature management of the hydrogen. Hydrogen produced by an electrolyzer or electrolytic cell is produced at temperature elevated above ambient. This elevated temperature decrease the density of the hydrogen gas. To provide a higher density of the hydrogen gas the elevated temperature of the hydrogen produced can be reduced by cooling the hydrogen as it flows and not simply reducing the rate of fill.

[0016] Temperature management can result in higher density of the hydrogen gas, which equates to more grams of hydrogen. The quantity of hydrogen dispensed to the end user, and the rate at which it is dispensed, should meet the reasonable convenience expectations of the end user.

[0017] Most preferably the time it should take to refill a fuel cell powered vehicle will be similar in duration to the time it takes to refuel an automobile with gasoline. Further, the quantity of hydrogen dispensed should have the potential to power a fuel cell powered vehicle a range of travel also within the reasonable convenience expectations of an end user.

[0018] In some instance the hydrogen storage tanks may be by-passed and the hydrogen from the hydrogen producing subsystem cooled and dispensed directly to an end user.

[0019] The electrolyzer may be powered by renewable source including to not limited to wind, hydroelectric and solar. Electricity from turbines and/or Photovoltaic panels can be connected to the electrolyzer or electrolytic cell to support hydrogen generation.

[0020] Other features and advantages of the present invention will be set forth, in part, in the descriptions which follow and the accompanying drawings, wherein the preferred embodiments of the present invention are described and shown, and in part, will become apparent to those skilled in the art upon examination of the following detailed description taken in conjunction with the accompanying drawings or may be learned by practice of the present invention. The advantages of the present invention may be realized and attained by means of the instrumentalities and combinations particularly pointed out in the appended claims.

BRIEF DESCRIPTION OF THE DRAWINGS

[0021] FIG. 1A is an overview of the transportable hydrogen refueling station.

[0022] FIG. 1B is an overview of the transportable hydrogen refueling station in use.

[0023] FIG. 2A is a partially cutaway view of a transportable hydrogen refueling station.

[0024] FIG. 2B is a table comparing the capacity of different configurations of the transportable hydrogen refueling station of FIG. 2A.

[0025] FIG. 3A is a semi-tanker.

[0026] FIG. 3B is a table of the specifications for the semi-tanker of FIG. 3.

[0027] FIG. 4 is a schematic of a transportable hydrogen refueling station.

[0028] FIG. 5A is a partial cutaway view of a self fueling transportable hydrogen refueling station.

[0029] FIG. 5B is a table comparing the capacity of different configurations of the hydrogen refueling station of FIG. 5A.

[0030] FIG. 6 is a schematic of a self fueling transportable hydrogen refueling station.

THE PREFERRED EMBODIMENTS OF THE INVENTION

[0031] A hydrogen refueling station 10 shown in FIGS. 1A, 1B and 2A is transportable. The hydrogen refueling station 10 or "hydrogen hauler" is useful to provide pressurized hydrogen gas to external hydrogen storage vessels. Those vessels may be part of a hydrogen powered motor vehicle 12.

[0032] The refueling station 10 is constructed on a substantially flat base 14, which supports a lightweight shell 16 into which the hydrogen storage, pressurization and distribution systems, are placed. An enclosure with its own base that can be detached or removed from the base 14 can be substituted for the lightweight shell 16. The base 14 is supported by axle mounted wheels 18. Vents 19 placed along the upper regions of the lightweight shell 16 allow any build up of gases to escape the shell 16.

[0033] The table provided in FIG. 2B indicates that the hydrogen refueling station 10 has a curb weight of under 5,500 pounds. The low curb weight is, in part, achieved by fitting the refueling station 10 with lightweight internal hydrogen storage tanks 100. Thus the refueling station 10 can be towed by a passenger vehicle.

[0034] Lightweight internal hydrogen storage tanks 100 should have a pressure rating of up to about 10,000 psi or more and a failure rating, or burst rating, of at least 2.25 times the pressure rating. One such hydrogen storage vessel is the Dynecell available from Dynetek Industries, Ltd. in Alberta, Canada. Another lightweight hydrogen storage vessel is the Tri-Shield available from Quantum Technologies, Inc. in Irvine, Calif.

[0035] The table provided in FIG. 2B indicates that a refueling station 10 with a curb weight of about 4,000 lbs (option A) should have a capacity of up to about 40 kg of hydrogen. The energy density measured as curb weight/quantity hydrogen for the 4,000 lb trailer is about 10 gm/lb (40,000 grams/4,000 lbs). A transportable hydrogen refueling station with a curb weight of about 5,500 lbs (option B) and a capacity of about 80 kg of hydrogen has an energy density of about 14.5 gm/lb (80,000 gm/5,500 lbs).

[0036] Conversely, a traditional tanker 20 for transporting hydrogen shown in FIG. 3A, the hydrogen filled tanker 20, according to its specifications provided in the table of FIG. 3B only has an energy density of about 5.3 gm/lb (320,000 gms/60,000 lbs). The refueling station 10 therefore has an energy density about twice the energy density of the semi-tanker.

[0037] FIG. 4 is a schematic of the refueling station 10. The refueling station 10 can be used to refuel a variety of

external hydrogen storage vessels and is not limited to supplying hydrogen to fuel cell powered vehicles, although such vehicles are one focus of the invention.

Filling the Refueling Station

[0038] Before the refueling station **10** can be used to supply hydrogen to an external hydrogen storage vessel **25**, the internal hydrogen storage tanks **100** in the refueling station **10** must be filled. A hydrogen storage subsystem **30** is provided within the transportable hydrogen refueling station **10** to refill or charge the lightweight composite hydrogen storage tanks **100**, a quick connect **32**, which can be any standard hydrogen connector, is used to connect an external hydrogen source to hydrogen storage subsystem **30**.

[0039] Downstream from the quick connect **32** is a pressure release valve **34**. The pressure release valve **34** is a safety element to prevent hydrogen, at a pressure exceeding a pre-determined maximum, from entering the hydrogen storage subsystem **30**. If the pressure of hydrogen being introduced through the quick connect **32** exceeds a safe limit a restrictive orifice **33** working in combination with a pressure relief valve **34** causes the excess hydrogen to be vented through a vent stack **36**. In general, the valves are used to affect the flow of hydrogen within the refueling station. A check valve **38**, between the vent stack **36** and pressure relief valve **34**, maintains a one way flow of the flow of pressurized hydrogen being relieved from the storage subsystem **30**. The restrictive orifice **33** also prevents the hydrogen from entering the pressure rated feed line **40** at a rate which causes extreme rapid filling of the lightweight hydrogen storage tanks **100**. Prior to connecting the quick connect **32** nitrogen gas, or other inert gas can be introduced into the feed line **40** to purge any air from the feed line. Pressurized nitrogen dispensed from a nitrogen tank **200** can be introduced through a nitrogen filling valve **202**.

[0040] The feed line **40** should be constructed of stainless steel and typically has a safety margin of 4. Safety margins for a pressurized hydrogen gas line are a measure of burst pressure to operating pressure. It is important to control the rate of fill of the hydrogen storage tanks **100** and in general the temperature of the gaseous hydrogen. Although a rapid fill is desired, physics dictates that as you increase the fill rate, all things being equal, an elevation in temperature will occur. With an elevation in temperature there is a corresponding decrease in the mass of hydrogen that can be stored at a predetermined input pressure. Accordingly, if the hydrogen entering the hydrogen storage tanks **100** is at an elevated temperature the density of the gaseous hydrogen will also be reduced. Cooling the gaseous hydrogen, by directing it through a cooling unit **300**, is used to reduce temperature elevations.

[0041] The cooling unit **300** in this embodiment is a finned tube type heat exchanger, however, other heat exchangers, coolers, or radiators which can manage the temperature of the gaseous hydrogen may be used. Temperature is measured at various places on the feed line **40** by temperature sensors **42** which are monitored by a system controller **400** which is typically based on a 8-32 bit microprocessor.

[0042] Connections between the feed line **40** sensors, valves, transducers, inlet or outlets, should be constructed to minimize any potential for leakage of hydrogen. Common construction techniques include welds, face seals, metal to

metal seals and tapered threads. One or more hydrogen leak sensors **43** are also distributed and connected to the system controller **400**. The pressure of the gaseous hydrogen is measured by one or more pressure sensors **44** placed in the feed line **40**. No specific sensors is called out for but generally the sensor may be a transducer, or MEMS that incorporate polysilicon strain gauge sensing elements bonded to stainless steel diaphragms. The temperature and pressure of the hydrogen, entering the pressure rated feed line **40** can be checked as it passes into the first compressor subsystem **50**.

[0043] The first compressor subsystem **50** contains an oil cooled first intensifier **52**. An intensifier switch **53**, connected to the system controller **400**, controls the start/stop function of the first intensifier **52**. An oil to air heat exchanger **54** for cooling hydraulic oil which is supplied to a first intensifier heat exchanger **56** to cool the first intensifier **52**. A hydraulic pump **58**, powered by a brushless motor **60**, supplies cooling oil from an oil reservoir **62** to the first intensifier heat exchanger **56**. A speed control **64** for the brushless motor **60** is provided. A brushless motor **60** is preferred to eliminate the risk of sparks. The system controller **400** receives data from the oil temperature sensor **65**, the gaseous hydrogen temperature sensors **42**, the gaseous hydrogen pressure sensors **44**, and the hydrogen leak sensors **43**. The system controller **400** in turn is used to, among other things, effect the speed control **64**.

[0044] The intensifier is a device, which unlike a simple compressor, can receive gas at varying pressures and provide an output stream at a near constant pressure. However, it may be suitable in some cases to use a compressor in place of an intensifier. The first intensifier **52** increases the pressure of the incoming gaseous hydrogen about four fold. Within the first compressor subsystem **50**, hydrogen gas from the feed line **40** enters the first intensifier **52** through an inlet valve **68**. The gaseous hydrogen exits the first intensifier through an outlet check valve **70**. At this point, the gaseous hydrogen is directed through a cooling unit **300** to manage any temperature increases in the gaseous hydrogen. The gaseous hydrogen passing through the cooling unit **300** may be directed to enter a second compressor subsystem **80** or into a by-pass feed line **90**.

[0045] If entering the second compressor subsystem **80** the gaseous hydrogen passes through an inlet check valve **82** which directs it to the second intensifier **84**. An intensifier switch **85**, connects to the system controller **400**, and controls the start/stop function of the second intensifier **84**. The gaseous hydrogen exits the second intensifier **84** through an outlet check valve **86** and is directed down the inlet/outlet line **88** to a line control valve **92** which directs the gaseous hydrogen through a cooling unit **300** and into the inlet/outlet control valves **94** and **94'** for the lightweight composite hydrogen storage tanks **100** and **100'**. The dual compressor sub-systems **50** & **80** are not a limitation. If the storage pressure for the hydrogen gas can be achieved with a single compressor sub-system, the second compressor subsystem can be bypassed or eliminated. By closing the inlet check valve **82** to the second intensifier **84**, the gaseous hydrogen exiting the first intensifier **52** is directed through the by-pass feed line **90** and to a by-pass inlet/outlet control valve **96** which directs the flow of gaseous hydrogen to the lightweight composite hydrogen storage tanks **100** and **100'**. Conversely, in those instances where storage pressure

exceeding that which can be efficiently achieved with dual intensifiers is desired, additional intensifiers can be added.

EXAMPLES

[0046] The following examples are given to enable those skilled in the art to more clearly understand and to practice the present invention. They should not be considered as limiting the scope of the invention, but merely as being illustrative and representative thereof.

Example 1

[0047] If the external hydrogen feed gas is supplied to the hydrogen storage subsystem **30** at approximately 1,000 psi then the first compressor subsystem **50** can increase the pressure of the hydrogen gas by up to about four times which would be as high as approximately 4,000 psi. However, if the desired storage is about 10,000 psi then the gaseous hydrogen is directed by the actions of the system controller **400** (i.e. opening and closing valves) from the first compressor subsystem **50** to the second intensifier subsystem **80**.

[0048] The pressure of gaseous hydrogen which enters the second compressor subsystem **80** at about 4,000 psi can be increased to achieve the desired 10,000 psi. As an additional fail safe, manual control valves **98** and **98'** may be affixed to each of the lightweight composite hydrogen storage tanks **100** and **100'** to physically prevent the flow of hydrogen gas in or out of the lightweight composite hydrogen storage tanks **100** and **100'**.

[0049] The system controller **400** can be used to maintain balance during the refilling of the lightweight composite hydrogen storage tanks **100** and **100'** by monitoring the pressure of each of the lightweight composite hydrogen storage tanks **100** and **100'** via adjacent pressure sensors **99** and **99'**. The system controller **400**, in turn can switch between storage tanks and select which tank to fill at a given time interval during the filling.

Example 2

[0050] If the external hydrogen feed gas is supplied to the hydrogen storage subsystem **30** at approximately 3,300 psi then the first compressor subsystem **50** can increase the pressure of the hydrogen gas by up to about four times which would be as high as approximately 9,900 psi. Accordingly, if the desired storage pressure of the hydrogen gas in the lightweight hydrogen storage vessels is about 10,000 psi the second compressor subsystem can be by-passed by keeping the inlet check valve **82** closed and directing the hydrogen gas to the by-pass inlet/outlet control valve **96**.

Self-Filling Refueling Station

[0051] In another embodiment shown in **FIGS. 5A and 5B** a hydrogen producing subsystem **500** is part of the hydrogen storage subsystem **30**. The hydrogen producing subsystem **500**, in this embodiment, is comprised of a KOH electrolyzer module **502** and a cooling module **504**. One suitable KOH electrolyzer is a IMET electrolyzer manufactured by Vandenberg Hydrogen Systems. The cooling module **504** should be sufficient to reduce the temperature to at or below ambient for maximum volume in the pressure rated hydrogen storage tanks **100**. The cooling module **504** may be a closed loop cooler, receive a water input, or use heat exchangers and or radiators.

[0052] The hydrogen producing subsystem **500** is affixed to the pressure rated feed line **40** upstream from the pressure release valve **34**. A hydrogen production controller (HPC) **550** can receive data from the oil temperature sensor **65**, the gaseous hydrogen temperature sensors **42**, the gaseous hydrogen pressure sensors **44** and the hydrogen leak sensors **43**. The HPC **550** in turn is used to, among other things, switch on and off the electrolyzer module **502** and can also effect the speed control **64**.

[0053] A polymer electrolyte membrane (PEM) cell may be substituted for the IMET electrolyzer. A PEM electrolyzer splits hydrogen from a water source and generates a hydrogen gas stream. Both the electrolyzer and the polymer electrolyte membrane are known in the art and therefore a detailed description of their construction is not necessary. Gaseous hydrogen produced by a PEM electrolyzer is also generated at a temperature which is elevated above ambient.

Refueling from the High Pressure Tanks

[0054] The refueling station **10** can be towed to a desired location. It can also be disconnected from the tow vehicle (**FIG. 1A**), or it can be transported from place to place.

[0055] The hydrogen fueling subsystem **110** is used to refuel an external hydrogen storage vessel **25** with pressurized hydrogen from the refueling station **10**. As the refueling begins after the system controller **400** will check pre-identified parameters, such as, temperature and pressure of the external hydrogen storage vessel, confirmation of ground connection and in some cases, confirmation from vehicles of readiness to fill, in order to determine whether hydrogen should be dispensed to the external hydrogen vessel **25**.

[0056] The actual hydrogen refueling process can be preceded by safety measures. Pressurized nitrogen, or other inert gas, may be introduced through a purge line **112** into the hydrogen dispensing feed lines **114** and **114'** to purge any air from the hydrogen dispensing feed lines **114** and **114'**. The purge is to manage the risk of dangerous hydrogen-air (oxygen) mixtures being formed and or being supplied to the external hydrogen vessel **25**. Purge pressure relief valves **120** and **120'** are appropriately located to vent gas from the hydrogen dispensing feed lines **114** and **114'**. In this embodiment, the system controller **400** also controls the nitrogen valve **202**.

[0057] The fill couplers **116** and **116'** can be any industrial or any standard hydrogen connector. A suitable fill connector is WEH TK 15 hydrogen fill nozzle by WEH of Germany in combination with a WEH-TN1 receptacle. Each fill coupler **116** and **116'** is connected to the refueling station **10** via break away couplers **118** and **118'**. A break away coupler **118** is another safety element not uncommon to refueling systems. A purge pressure relief valve can vent hydrogen to a vent **121** and **121'** from the hydrogen dispensing line if a break away coupler is decoupled.

[0058] One proposed industry standard for a fuel cell vehicle fill coupler is described in the proposed "Fueling Interface Specification" prepared by the California Fuel Cell Partnership that description which is hereby incorporated by reference. The fill coupler, indicated in the proposed "Fueling Interface Specification", has a "smart" connect which, among other parameters, checks the pressure, temperature and volume of hydrogen within the tanks of a vehicle **12** (the

external hydrogen storage vessel 25) being refueled. It will also check that the vehicle is grounded.

[0059] The “smart” fill coupler can communicate with the refueling station 10 through the system controller 400 or other data processor, controller and or computer (not shown). A user interface panel 600 may also be provided whereby the user may confirm conditions, enter data or otherwise communicate with the refueling station 10.

[0060] After the external hydrogen vessel 25 and the fill coupler 116 are connected, recharging or filling of the hydrogen receptacle can occur. The fill coupler should meet or exceed the appropriate governmental or industry mechanical specifications to fill the hydrogen storage vessel at a pressure not to exceed any predetermined pressure rating thereof.

[0061] When refueling or recharging an external hydrogen storage vessel 25 preferably a map of the external hydrogen vessel 25 should be obtained. A map should check the temperature, volume and pressure of the hydrogen gas in the external hydrogen vessel 25 and the volume pressure and temperature of the hydrogen in each lightweight composite hydrogen storage tanks 100 and 100'. It is also envisioned that the map may include information about the pressure rating and capacity of the external hydrogen vessel 25. The pressure rating and capacity information could alternatively be input on the interface panel 600 and or transmitted via a smart connect. External hydrogen vessel 25 identification information could be received by the system controller 400 which can use a look up table (LUT) to set the refueling parameters.

[0062] One pathway of the hydrogen gas being dispensed is from the pressure rated tanks 100 and 100', via the inlet/outlet control valves 94 and 94', through the cooling unit 300, then via the line control valve 92 into the inlet/outlet feed line 88.

[0063] The cooling unit 300 can reduce the temperature of the hydrogen gas by about at least 20° C., more preferable by about at least 40° C. and most preferably by about at least 80° C.

[0064] By controlling the temperature of the hydrogen gas during refueling a faster refueling can take place. If the temperature of the hydrogen in the external hydrogen vessel 25 increase past ambient the volume of hydrogen which the external hydrogen vessel 25 can store is decreased. If the temperature increase is as little as about 20° C. from 20 to 40 volume may be decreased by about 6%. If that temperature increase is about 40 degrees volume may be decreased by about 12%. If the temperature increase is about 80 degrees volume may be decreased by about 22%.

[0065] Temperature management supports faster dispensing of dense gaseous hydrogen. An end user or consumer may have convenience expectations such as a reference on the time interval it took to refuel a gasoline powered combustion automobile, and how the combustion automobile could travel on the quantity of gasoline received during the time interval. To meet convenience expectations, a hydrogen refueling station should dispense enough hydrogen (grams), in a similar time interval, to potentially travel a similar distance.

[0066] The hydrogen gas, in the inlet/outlet feed line 88, is directed to one or both of the hydrogen dispensing feed lines 114 and 114' via a dispensing line check valve 97.

[0067] When dispensing the gaseous hydrogen, the system controller 400 can be used to select between the lightweight composite hydrogen storage tanks 100 and 100' by comparing pressure in the lightweight composite hydrogen storage tanks 100 and 100' and the external hydrogen storage vessel 25 to balance the pressure. Pressure balancing between sources is a known mechanism used to more efficiently dispense gaseous fuels from multiple pressurized sources. The system controller 400 controls the control valves and check valves during the dispensement of hydrogen (refueling) to an external hydrogen vessel 25. Refueling can normally continue until an external hydrogen storage vessel 25 reaches a selected or predetermined fill pressure.

[0068] At the completion of refueling, in conjunction with decoupling a fill coupler 116 or 166' from an external hydrogen vessel 25 or 25', a decoupling control valve 122 or 122' directs the hydrogen, in that portion of a hydrogen dispensing feed lines 114 or 114' via break away couplers 118 or 118' and fill coupler 116 or 166', to a vent 121 or 121'. Venting the hydrogen will depressurize the portion of the hydrogen dispensing feed lines 114 or 114' connected to the fill coupler 116 or 166'.

Refueling Direct

[0069] The embodiment shown in FIG. 6 can also be used to dispense gaseous hydrogen directly to an external hydrogen storage vessel 25. The system controller 400 can shut off the inlet/outlet control valves 94 and 94' and direct the gaseous hydrogen from the first or second compressor subsystems 50 or 80 through the inlet/outlet feed line 88.

[0070] During a direct refill the gaseous hydrogen from the electrolyzer module 502 passes through the cooling module 504 to reduce the elevated temperature of the gaseous hydrogen produced by the electrolyzer module 502. At this point, without any further cooling the dispensed hydrogen will have a greater density than hydrogen dispensed directly from the electrolyzer module 502.

[0071] To further reduce the temperature of the hydrogen exiting the cooling module, the gaseous hydrogen output from either the first or second compressor subsystems 50 or 80 passes through a cooling unit 300 before being dispensed to an end user.

[0072] Since certain changes may be made in the above apparatus without departing from the scope of the invention herein involved, it is intended that all matter contained in the above description, as shown in the accompanying drawing, shall be interpreted in an illustrative, and not a limiting sense.

1. A hydrogen refueling station comprising:
 - a portable enclosure;
 - at least one feed line whereinto hydrogen can flow;
 - at least one compressor means, within the enclosure, connected to the at least one feed line;
 - one or more hydrogen storage tanks, within the enclosure, connected to the at least one feed line downstream from the at least one compressor means;
 - at least one control valve connected to the at least one feed line;

- at least one reversible connector, whereby hydrogen from the at least one hydrogen storage tank can be dispensed;
- at least one cooling means, wherethrough hydrogen can flow; and,
- at least one system controller to control at least one of the at least one control valve or the at least one compressor means, whereby the flow of hydrogen within the refueling station is affected.
2. The transportable hydrogen refueling station of claim 1 wherein each of at least one compressor means is selected from the group consisting of a compressor and an intensifier.
3. The transportable hydrogen refueling station of claim 1 wherein each compressor means comprises an oil cooled intensifier.
4. The transportable hydrogen refueling station of claim 1 wherein at least one or more hydrogen storage tanks have a burst pressure rating of at least 12,000 psi.
5. The transportable hydrogen refueling station of claim 2 wherein one or more hydrogen storage tanks can store at least 3,500 grams of hydrogen.
6. The transportable hydrogen refueling station of claim 1 wherein the gross loaded weight of the refueling station is less than about 4,000 pounds.
7. The transportable hydrogen refueling station of claim 2 wherein one or more hydrogen storage tanks can store at least 7,500 grams of hydrogen.
8. The transportable hydrogen refueling station of claim 1 wherein the gross loaded weight of the refueling station is less than about 5,500 pounds.
9. The transportable hydrogen refueling station of claim 1 wherein each of at least one cooling means is selected from the group consisting of heat exchangers, coolers and radiators.
10. The hydrogen refueling station of claim 1 wherein the portable enclosure is a trailer.
11. A hydrogen re-fueling system comprising:
- a portable enclosure;
- one or more hydrogen storage tanks, within the enclosure;
- at least one reversible connector, whereby hydrogen from at least one hydrogen storage tank can be dispensed;
- at least one control valve;
- at least one cooling means, wherethrough hydrogen can flow; and,
- at least one system controller to control at least one control valve, whereby the flow of hydrogen to the reversible connector is affected.
12. The hydrogen refueling station of claim 11 wherein the portable enclosure is a trailer.
13. The transportable hydrogen refueling station of claim 11 wherein at least one or more hydrogen storage tanks have a burst pressure rating of at least 22,500 psi.
14. The transportable hydrogen refueling station of claim 11 wherein one or more hydrogen storage tanks can store at least 35 grams of hydrogen.
15. The transportable hydrogen refueling station of claim 11 wherein each of at least one cooling means is selected from the group consisting of heat exchangers, coolers and radiators.

16. A hydrogen refueling station comprising:
- a portable enclosure;
- at least one feed line whereinto hydrogen can flow;
- a hydrogen producing subsystem, which has at least a hydrogen producing unit and a hydrogen cooling unit, connected at one end to the feed line;
- at least one compressor means, within the enclosure, connected to at least one feed line downstream from the hydrogen producing subsystem;
- one or more hydrogen storage tanks, within the enclosure, connected to at least one feed line downstream from at least one compressor means;
- at least one control valve connected to at least one feed line;
- at least one reversible connector, whereby hydrogen from at least one hydrogen storage tank can be dispensed;
- at least one cooling means, wherethrough hydrogen can flow; and,
- at least one system controller to control at least one control valve, at least one compressor means, and the hydrogen producing subsystem whereby the flow of hydrogen within the refueling station is affected.
17. The hydrogen refueling station of claim 16 wherein the portable enclosure is a trailer.
18. The hydrogen refueling station of claim 16 wherein the hydrogen producing unit is a KOH electrolyzer.
19. The hydrogen refueling station of claim 16 wherein the hydrogen cooling unit is a closed loop cooler.
20. The hydrogen refueling station of claim 16 further comprising a tank of pressurized inert gas connected to at least one feed line; whereby introduction of the inert gas into the feed line will purge at least a portion of the feed line and/or the reversible connector.
21. The hydrogen refueling station of claim 16 further comprising a tank of pressurized inert gas connected to at least one feed line; whereby introduction of the inert gas into the feed line will purge at least a portion of the feed line and/or the reversible connector.
22. The hydrogen refueling station of claim 16 further comprising a tank of pressurized inert gas connected to at least one feed line; whereby introduction of the inert gas into the feed line will purge at least a portion of the feed line and/or the reversible connector.
23. The hydrogen refueling station of claim 16 further comprising a tank of pressurized inert gas connected to at least one feed line; whereby introduction of the inert gas into the feed line will purge at least a portion of the feed line and/or the reversible connector.
24. A hydrogen refueling station comprising:
- a portable enclosure;
- at least one feed line whereinto hydrogen can flow;
- a hydrogen producing subsystem, which has at least a hydrogen producing unit and a cooling unit, connected at one end to the feed line;
- at least one compressor means, within the enclosure, connected to at least one feed line;
- one or more hydrogen storage tanks, within the enclosure, connected to at least one feed line downstream from at least one compressor means;

at least one control valve connected to at least one feed line;

at least one reversible connector, whereby hydrogen from at least one hydrogen storage tank can be dispensed;

at least one cooling means, wherethrough hydrogen can flow,

at least one system controller to control at least one control valve or at least one compressor means, whereby the flow of hydrogen within the refueling station is affected; and a second system controller to control the hydrogen producing subsystem.

25. The hydrogen refueling station of claim 1 further comprising inert gas to purge at least a portion of the feed line.

* * * * *