



US 20060124021A1

(19) **United States**

(12) **Patent Application Publication**
Urwin

(10) **Pub. No.: US 2006/0124021 A1**

(43) **Pub. Date: Jun. 15, 2006**

(54) **HIGH VELOCITY PROJECTILES**

Publication Classification

(76) **Inventor: Richard William Ross Urwin**, New South Wales (AU)

(51) **Int. Cl.**
F42B 12/08 (2006.01)

(52) **U.S. Cl.** **102/476**

Correspondence Address:
GREENBLUM & BERNSTEIN, P.L.C.
1950 ROLAND CLARKE PLACE
RESTON, VA 20191 (US)

(57) **ABSTRACT**

A shaped charge and projectile combination for firing from a weapon, the combination including projectile (3), shaped charge (1) of high explosive material and metal liner (2) located between charge (1) and projectile (3). Charge (1) includes detonator (6) and cavity (4) in an external face facing the muzzle of the weapon, cavity (4) being shaped to axially concentrate explosive on detonation of charge (1) towards the rear (5) of projectile (3). Metal liner (2) forms a jet of liner material on detonation of charge (1) to impact the rear (5) of projectile (3) and so propel projectile (3) from the weapon at high velocity, typically greater than 1000 m/s and up to 6000 m/s. Projectile (3) therefore travels a flatter trajectory and has a higher penetrating power than a conventionally propelled projectile.

(21) **Appl. No.: 10/524,513**

(22) **PCT Filed: Aug. 12, 2002**

(86) **PCT No.: PCT/AU02/01076**

(30) **Foreign Application Priority Data**

Aug. 10, 2001 (GB) 0119502.3

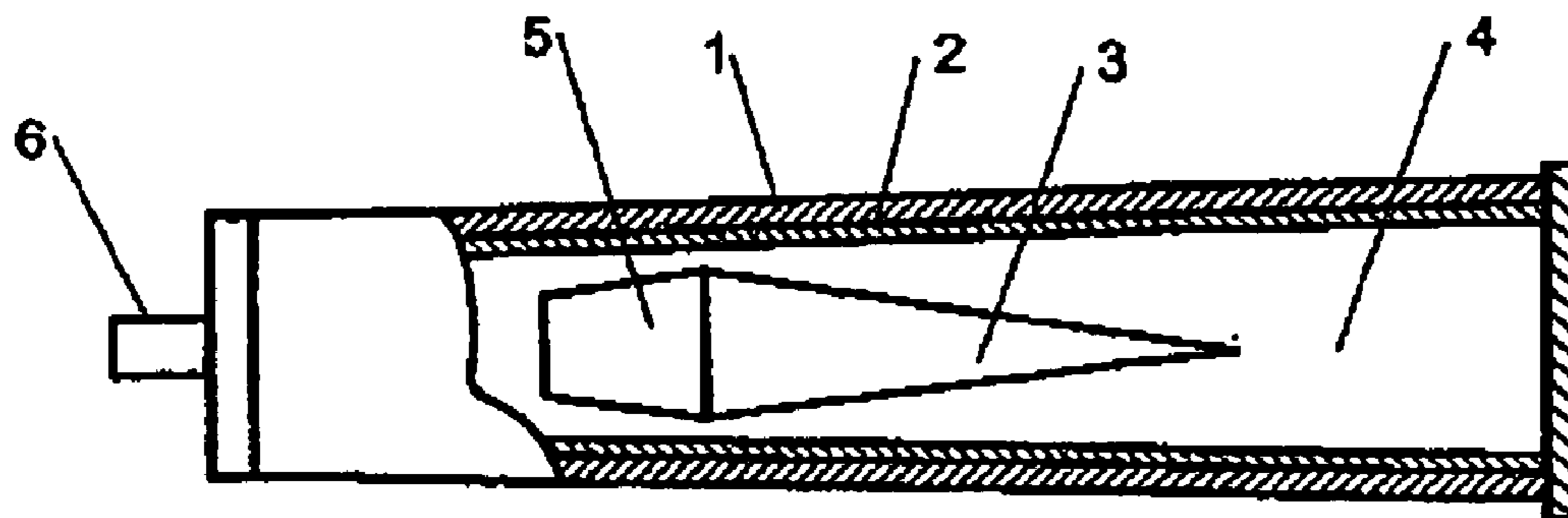

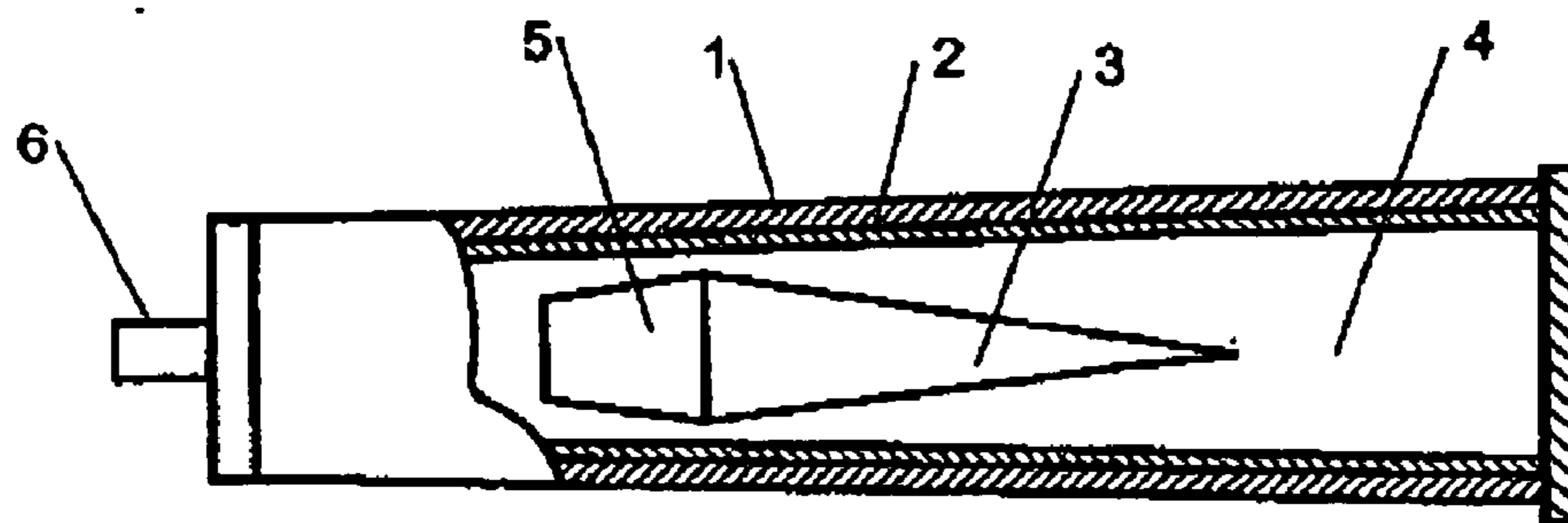

FIGURE 1

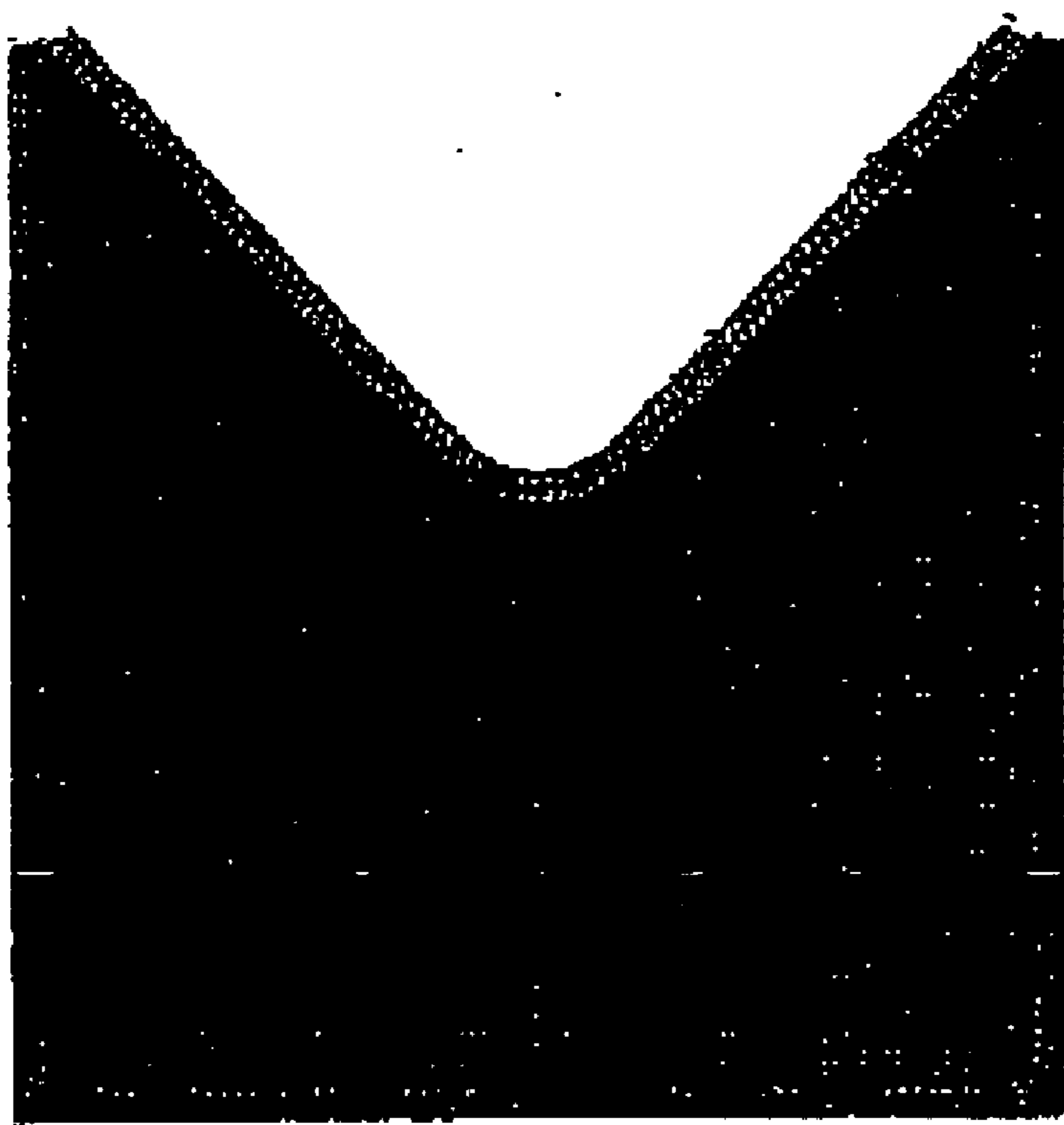

FIGURE 2

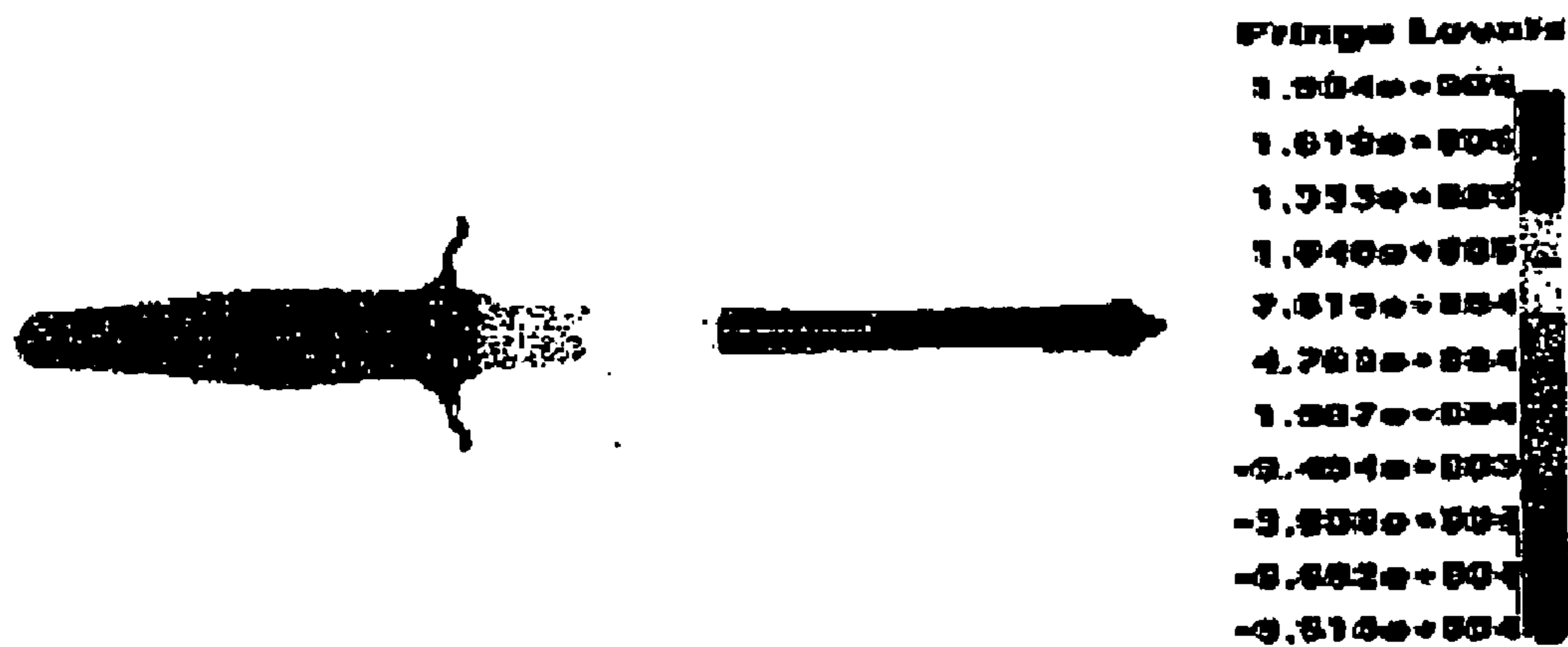

FIGURE 3



FIGURE 4

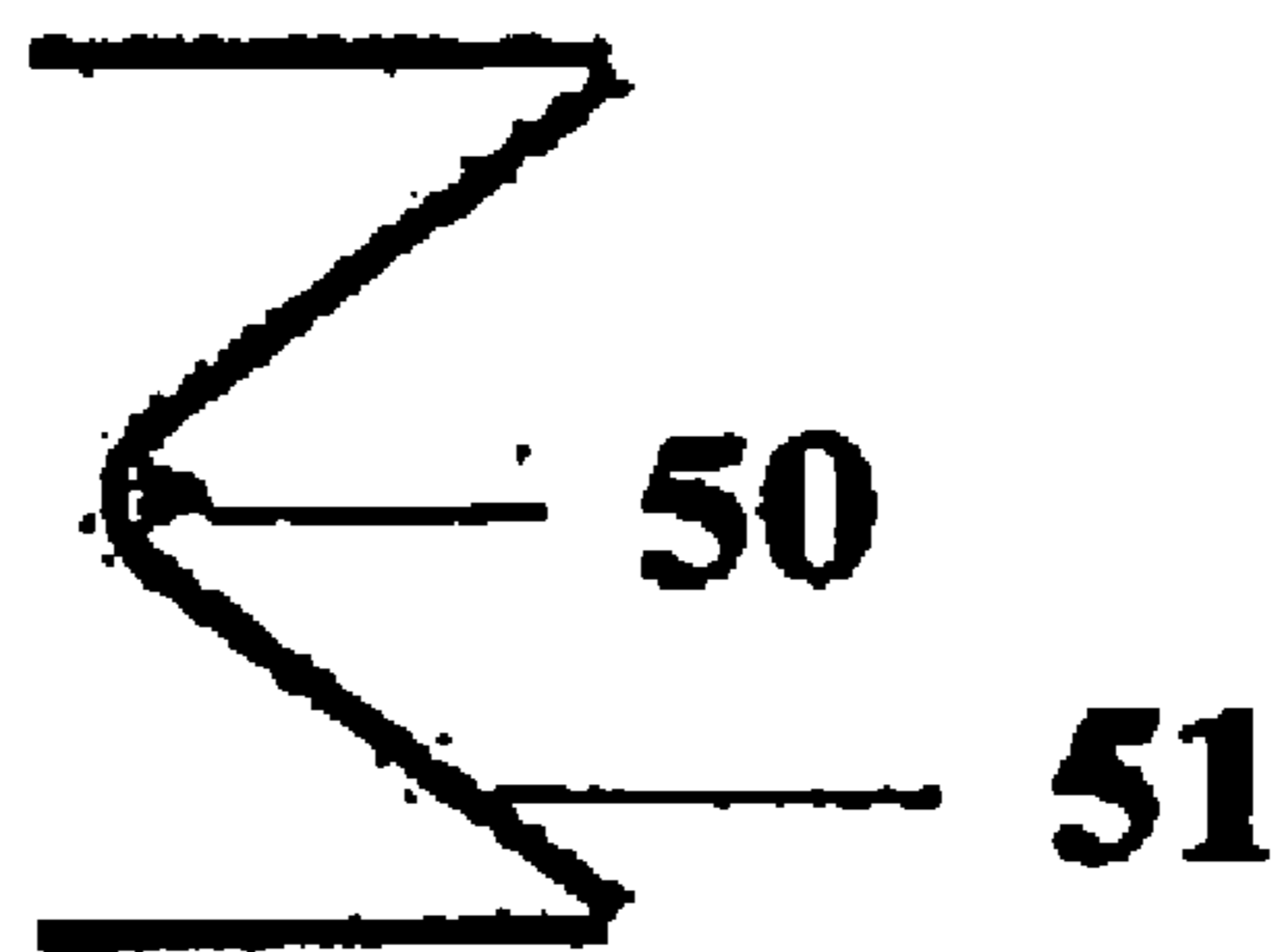

FIGURE 5A

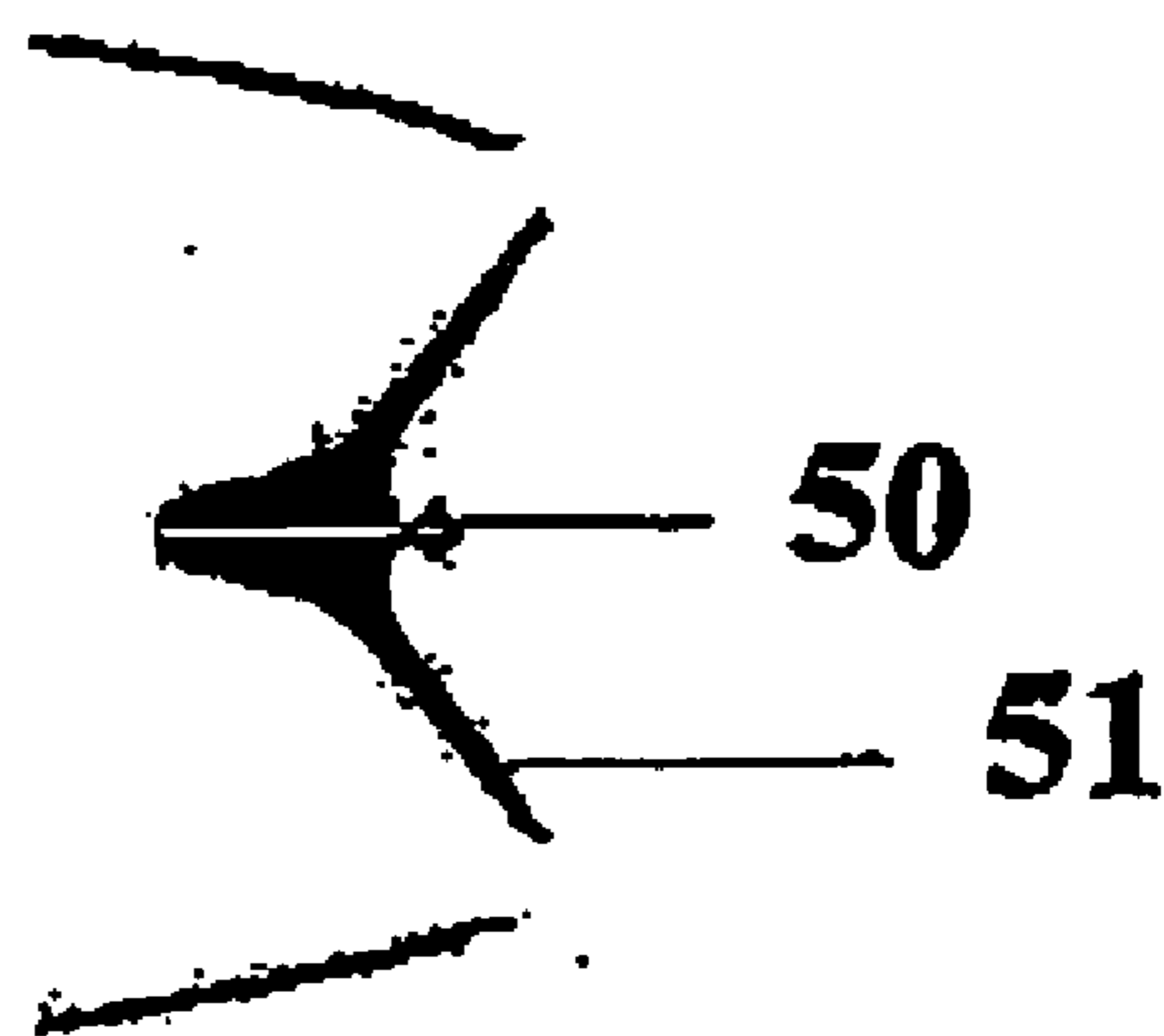

FIGURE 5B

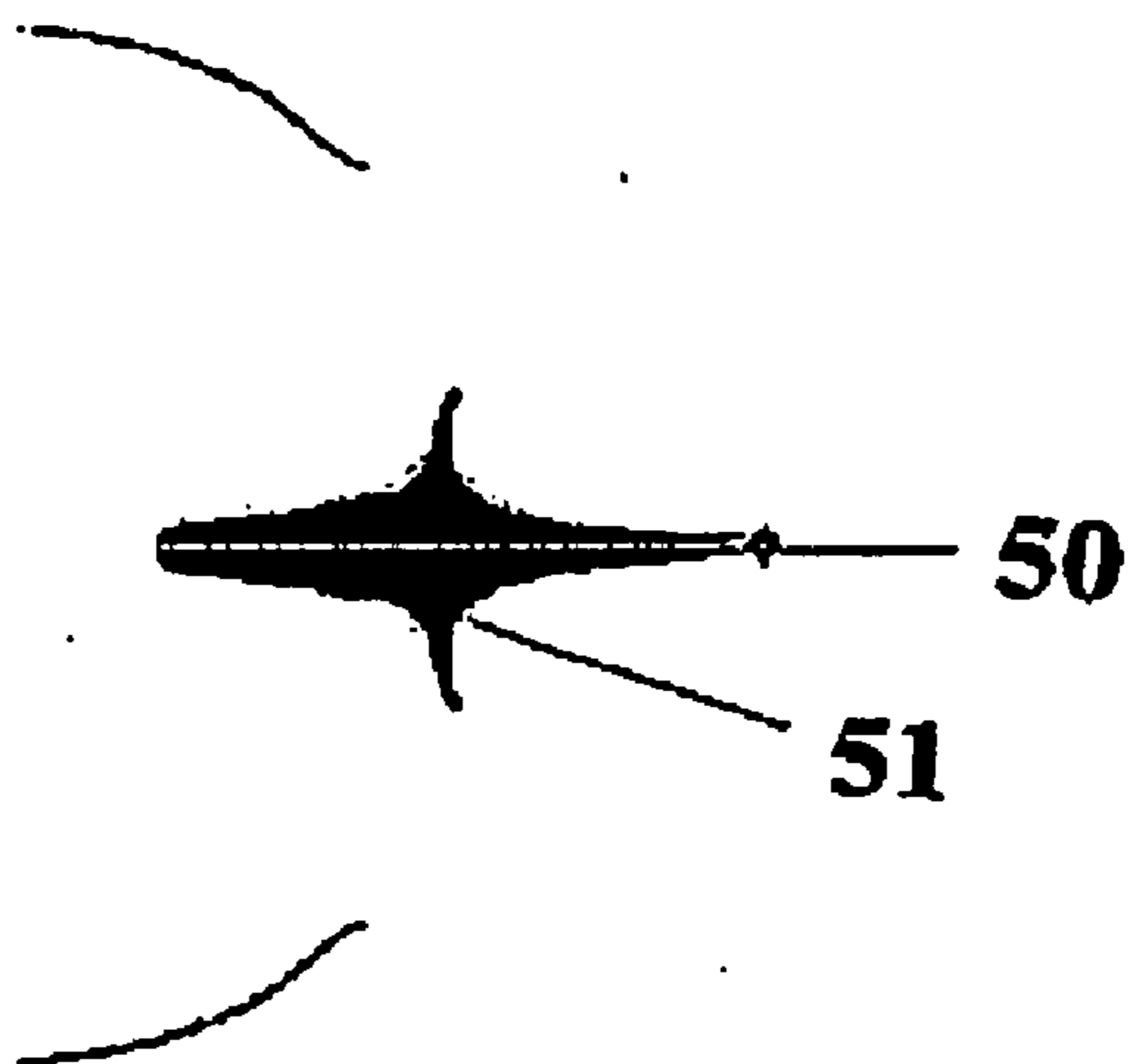

FIGURE 5C

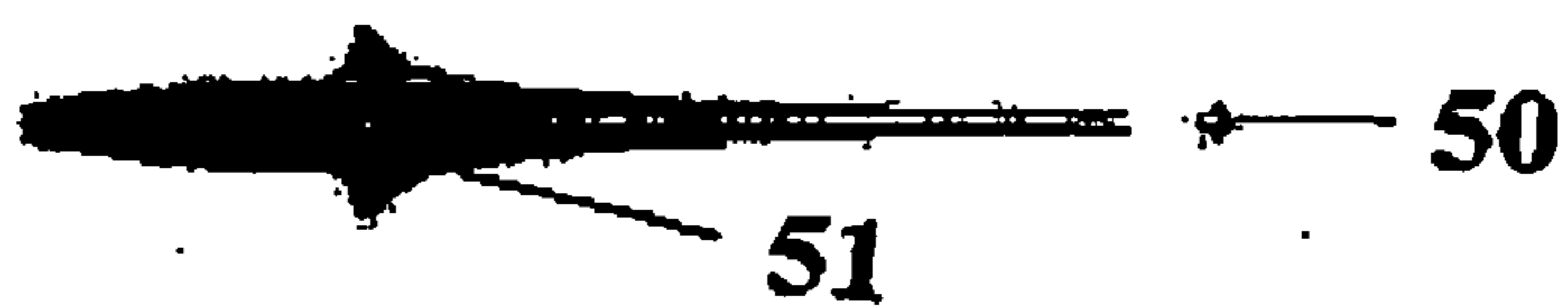

FIGURE 5D

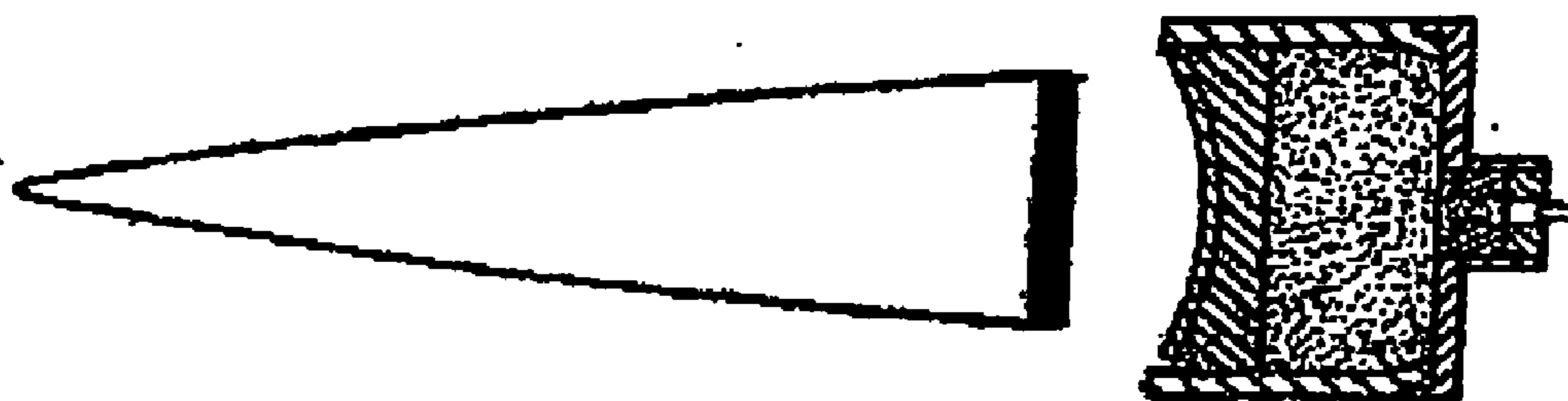

FIGURE 6

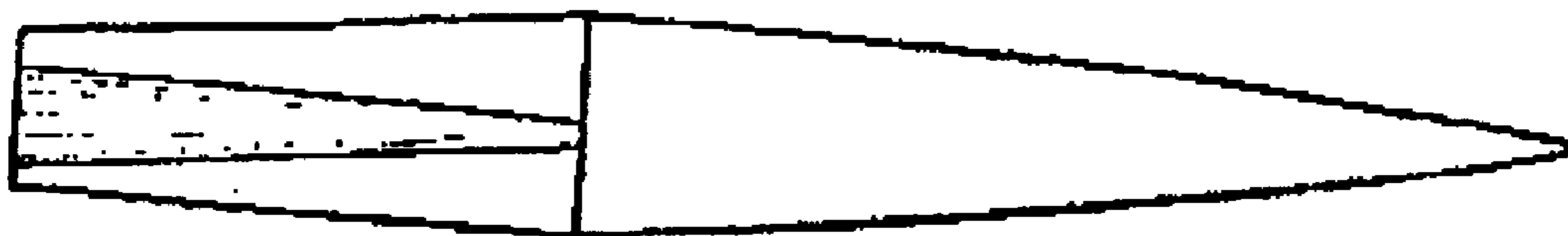

FIGURE 7

HIGH VELOCITY PROJECTILES

FIELD OF INVENTION

[0001] The invention relates to high velocity projectiles and in particular to combinations of shaped charges and projectiles where detonation of the shaped charge causes a liner to deform and be accelerated providing kinetic energy to a projectile.

BACKGROUND

[0002] Guns typically use gas pressure within a barrel to propel a projectile. Examples include air rifles and armaments using low velocity explosive such as cordite or black powder that contributes to provide sufficient volume and/or pressure of gas within the confines of a barrel to propel a projectile such as a bullet or shell from the barrel of the gun. For example, cordite is a combustible rather than explosive material, such that the detonation of a primer will ignite the cordite to create sufficient gas pressure to propel the bullet. Guns are typically provided with a rifled barrel to spin the bullet and assist in stability of the bullet along its flight path and hence accuracy of the bullet. Some guns do not use a rifled barrel, for example shot guns, where a number of projectiles (shot) are propelled by combustion of explosive along the barrel.

[0003] There have been many attempts to produce high speed projectiles. Examples include using longer gun barrels, using rockets or other propulsion means to aide the transfer of kinetic energy to the projectile. Further examples also include linear motors and hydrogen guns both of which require long barrels. Long barrelled weapons are not suitable in combat situations.

[0004] In military applications, tanks and other armoured vehicles have made use of new materials for armour making it more difficult to design guns that fire projectiles capable of penetrating the armour. Similarly advances in body armour have made it difficult for conventional bullets to penetrate the armour and injure the wearer.

[0005] A shaped charge or metal lined cavity shaped charge is a metal lined high explosive charge with a mainly hemispherical or conical cavity. Upon detonation of the explosive of the shaped charge the detonation wave sweeps forward and begins to collapse the metal liner at its apex. The explosive force compresses and deforms the metal liner and produces a molten (or metal) jet moving at very high speed. This jet reaches speeds in excess of 4 to 12 km/s. The production of the metal jet is termed the 'Munroe effect'. Shaped charges of this type produce a metal jet that is a useful penetrating and perforating device.

[0006] However, one problem with shaped charges is that the effective range of the molten jet is very limited. Due to the nature of detonation and the design of the shaped charge liner the production of the molten jet is not consistent. The jet also has a large variation in mass and velocity over its length and breaks up after travelling a short distance.

[0007] Due to the large gradient in mass and velocity, detonation of the shaped charge must occur a specific distance from the target for the jet to obtain the greatest speed possible before it begins to perforate the target. If the charge is detonated too far from the target the ejected liner material will have broken up into small pieces before

reaching the target and the speed of the jet will have slowed. If the shaped charge is detonated too close to the target the jet may not have reached ideal speed and performance may be reduced.

SUMMARY OF INVENTION

[0008] In broad terms in one aspect the invention comprises a shaped charge and projectile combination including a projectile, a shaped charge of high explosive material including a cavity in an external face of the charge, shaped to axially concentrate explosive upon detonation of the shaped charge towards the projectile, and a metal liner between the shaped charge and the projectile, to form a jet of liner material on detonation of the shaped charge to impact the rear of and propel the projectile.

[0009] The shaped charge and projectile may be combined into a cartridge.

[0010] In broad terms in a further aspect the invention comprises a shaped charge and projectile in combination including a projectile, a body of a high explosive material forming a charge and including an internal cavity open to one end of the charge to axially concentrate explosive force upon detonation of the shaped charge towards the rear face of the projectile, and a metal layer lining the interior of the cavity in the shaped charge.

[0011] In broad terms in a further aspect the invention comprises a method of propelling a projectile including providing a projectile, providing a shaped charge of high explosive material including a cavity in an external face of the charge, the cavity shaped to axially concentrate explosive upon detonation of the shaped charge towards the projectile and a metal liner between the shaped charge and the projectile, detonating the shaped charge at an end opposite the cavity to form a jet of liner material, and focus the jet on the rear of the projectile so that at least a portion of the kinetic energy of the jet is transferred to the projectile to propel the projectile.

BRIEF DESCRIPTION OF DRAWINGS

[0012] The invention will be further described with reference to the accompanying figures, by way of example and without intending to be limiting, wherein:

[0013] **FIG. 1** shows an example combination shaped charge and projectile;

[0014] **FIG. 2** shows a shaped charge and liner;

[0015] **FIG. 3** shows the results of a simulation showing a jet of molten material being formed from a liner;

[0016] **FIG. 4** shows the results of a simulation showing a jet of molten material formed from a liner providing kinetic energy to a projectile;

[0017] **FIG. 5A** shows a projectile and shaped charge with liner before detonation;

[0018] **FIG. 5B** shows a simulation of the shaped charge, liner and projectile after detonation of the explosive of the shaped charge;

[0019] **FIG. 5C** shows a simulation of the shaped charge, liner and projectile after detonation as the liner forms a jet.

[0020] FIG. 5D shows a simulation of the liner and projectile after detonation of the shaped charge.

[0021] FIG. 6 shows a combination shaped charge and projectile including a ballistic disk; and

[0022] FIG. 7 shows a projectile with a jet trap.

DETAILED DESCRIPTION

[0023] FIG. 1 shows an example of the combination of shaped charge and projectile of the invention. The shaped charge 1 has a substantially cylindrical or frusto conical outer shape of high explosive with a cavity 4 facing the open end of a firing weapon. The boundary between cavity 4 and the high explosive 1 is provided with metal liner 2. Housed inside cavity 4 is projectile 3. The high explosive of the shaped charge is also provided with detonation means 6.

[0024] When the explosive is detonated the liner forms into a jet of molten material that impacts the rear of the projectile. At least a portion of the kinetic energy of the liner is passed to the projectile and propels the projectile. Because the projectile is a free moving object the impact of the jet on the projectile propels both the projectile and jet along the original axis of movement of the jet. Ideally this axis of movement of the jet is the central axis of the barrel of the firing weapon. The axis is also ideally coaxial to the central axis of the projectile.

[0025] The explosive used in the shaped charges is high explosive. By high explosive is meant an explosive material with a detonation velocity in excess of 1000 m/s. Examples of the high explosives include Semtex, TNT, RDX and PETN.

[0026] The explosive charge and liner are shaped such that on detonation of the explosive charge the liner forms a jet of molten material coaxial with the centre axis of the projectile. The back of the projectile 5 is formed from a material able to withstand the high temperatures and force of the jet. Suitable materials include, but are not limited to, carbon, titanium, tungsten, ceramics, steel, uranium and depleted uranium. In some cases the rear of the projectile 5 may include an aperture to increase the surface area of the rear of the projectile and the area on which the jet will impact.

[0027] The combination of shaped charge and projectile shown in FIG. 1 is suitable for fixed diameter weapons including barrelled weapons. In the combination shown in FIG. 1 the projectile has smaller calibre than the charge and will not be in close contact with the inside of the barrel of the weapon. In combinations such as that of FIG. 1 the barrel of the weapon will therefore not require rifling although these combinations are suitable for use in weapons with rifled barrels. In combinations such as that of FIG. 1 the projectile may be provided with stabilising means such as fins to provide stability to the flight path of the projectile once it has exited the weapon.

[0028] In other combinations the projectile may be of the same or greater calibre than the shaped charge. In these systems if the projectile is same calibre as the weapon and the barrel of the weapon is provided with rifling the projectile may be designed to interact with the rifling and thus provide spin and stability to the projectile.

[0029] The combination of shaped charge and projectile allows the projectile to be propelled at high velocity, typi-

cally greater than 1000 m/s. The precise speed of the projectile will depend on many things including the high explosive chosen for the shaped charge, the relative sizes of the shaped charge and projectile, the geometry of the explosive (i.e. the precise shape of the shaped charge), the point of detonation, the mass and geometry of the metal liner, the distance between the liner and the projectile, the way the detonated explosive decomposes, the material of the liner, and the weight, size and material of the projectile.

[0030] The use of high explosive provides more propelling force than a low explosive. Different types of high explosive provide different propelling forces. A larger shaped charge containing high explosive will provide more explosive force than a smaller shaped charge containing the same high explosive.

[0031] The geometry of the shaped charge also has an effect on the propelling power of the jet on the projectile. A shaped charge with a cylindrical cavity produces a jet that is a function of the length of the cylinder. For a shaped charge with a cylindrical cavity varying the amount of explosive and liner along the cavity can vary the jet production. In the case of a shaped charge with a cylindrical cavity the liner the cylinder the greater the length of jet produced. In a shaped cue with a conical or hemispherical cavity and liner the length of the jet increases as a function of the diameter of the charge. In a shaped charge with a conical cavity the angle between the liner and the central axis of the charge also affects the jet formed. The smaller the angle the faster the speed of the jet formed.

[0032] The larger the shaped charge is in relation to the size of the projectile the larger the force provided to the jet will be in relation to the projectile and the more kinetic energy will be imparted to the projectile.

[0033] As described above the geometry of the metal liner affects the jet. The liner has the same shape as the outer boundary of the shaped charge. For example a cylindrical liner will form a jet the length of which depends on the length of the cylinder. The mass of the liner material also affects the density and speed of the jet.

[0034] The distance between the liner and the projectile also affects the performance of the projectile. If the projectile is too close to the liner the projectile may be consumed or deformed by the jet. If the projectile is too far from the liner the jet formed from the liner may have lost kinetic energy or start to break up before providing kinetic energy to the projectile.

[0035] Performance of the projectile is also affected by the dimensions of the projectile. Ideally the projectile is light, strong and has temperature resistant material covering at least the rear of the projectile. In some embodiments the projectile may be completely covered with a layer of temperature resistant material. As stated previously suitable materials include, but are not limited to, carbon, titanium, tungsten, ceramics, steel, uranium and depleted uranium.

[0036] FIG. 2 shows a shaped charge and liner that may be used in combination with a projectile. The shaped charge includes an outer casing, central area of high explosive and a cavity that is lined with a liner. As described above the shape of the cavity and liner affects the formation of the Jet of molten material from the liner.

[0037] When the shaped charge is detonated a high temperature high intensity jet will be focused on the rear of the projectile with a detonation velocity in excess of 1000 m/s and typically of the order of 5000-6000 m/s depending of the explosive material chosen for use in the shaped charge. The high explosive of the shaped charge may be Semtex or other suitable high explosive material.

[0038] Any suitable detonator may be used to detonate the high explosive of the shaped charge. For example, the shaped charge may be detonated by physical impact by means of a firing pin or by means of electrical detonation. Electrical detonation has the advantage of precise timing of ignition, rapid ignition and it prevents instability that might occur though the physical movement of a firing pin. The high explosive of the shaped charge may also be detonated by laser detonation. Laser detonation has the same advantages as electrical detonation. Electrical and laser detonation also enables the combination shaped charge and projectile of the invention to be used with guns that have a safely mechanism where the gun will not fire unless an appropriate electrical device (such as an identity card) is in close proximity to the gun. Alternatively biometrics, such as fingerprint or facial recognition may be used as a safety mechanism.

[0039] By using a shaped charge, and by transferring as much as possible of the kinetic energy of the jet of molten material into the kinetic energy of the projectile it is possible to cause the projectile to travel at higher velocities than conventional bullets. By increasing the velocity of the projectile, for example a bullet, to 1000 m/s or more the bullet can travel in a much flatter trajectory that normal, have a much shorter time between the launcher and the target, and have a much higher impact velocity allowing the bullet to penetrate a range of different armours. The projectiles of the combination projectile and shaped charge of the invention have higher kinetic energy than conventional projectiles and can therefore create more damage on impact. This in turn means that the projectile is more effective over a greater distance than a conventional bullet or shell. It also enables guns to be redesigned to have a much greater range and killing power for a lighter gun than conventional guns.

[0040] Although the projectile describe here has been referred to as a bullet the projectile for use with a shaped charge in the combination of the invention is not limited to bullets. The projectiles may be shells, missiles or any projectile designed to be propelled from a weapon by detonation of an explosive charge. In cases where the projectile is travelling long distances or includes a guidance system the projectile may be provided with rockets for stabilisation and/or to provide further propulsion.

[0041] Projectiles used as part of the invention may require stabilisation means. If the projectile has the same calibre as the internal diameter of the barrel of the weapon used to fire the projectile, the projectile may include means to interact with any rifling in the barrel. In other embodiments, such as those shown in FIGS. 1 and 5A to 5D where the projectile is smaller than the internal diameter of the barrel, the projectile may be provided with fins or other stabilising means, that may stabilise the projectile with or without spinning the projectile. Projectile of the same calibre as the barrel of the weapon from which they are fired (as well as those with smaller calibre than the barrel) may be

provided with stabilisation means such as dimples, grooves or other indentations. The stabilisation means may be arranged to smooth the path of the projectile over its trajectory or provide stability by spinning the projectile. Combinations of the abovementioned stabilisation means may be used.

[0042] FIG. 3 is a computer simulation of the jet produced from the shaped charge of FIG. 2. This Figure shows the jet of deformed liner material approximately 14.5×10^{-6} seconds after detonation of the high explosive shaped charge. The key at the right hand side of the figure shows the velocity gradient of the jet. In this figure and subsequent figures the direction of movement of the jet is from left to right. As can be seen from this figure the velocity of the jet is greatest at the right hand side of the jet indicating that the front of the jet is moving more quickly than the rear of the jet. The jet continues to lengthen further and the front of the jet continues to have greater velocity than the rear of the jet. Eventually the jet breaks into at least two pieces, a faster moving front piece and a slower moving rear piece.

[0043] FIG. 4 is a computer simulation showing a jet and a projectile approximately 14×10^{-6} seconds after detonation at the high explosive shaped charge. As with FIG. 3 the key at the right hand side of the Figure shows the velocity gradient of the jet. As can be seen from the figure the jet is providing kinetic energy to the projectile and the projectile has greater velocity than the jet. Further firing images are shown in FIGS. 5A to 5D.

[0044] FIGS. 5A to 5D show a computer simulation of the detonation of a combination shaped charge and projectile of the invention. FIG. 5A shows the arrangement of the shaped charge and projectile 50 before detonation. In this example the projectile is conical with height of 2 mm and base of 2 mm. The outer diameter of the shaped charge is 25.4 mm. The shaped charge has a conical cavity and liner 51 is provided at the boundary between is explosive of the shaped charge and the cavity.

[0045] FIG. 5B shows a moment approximately 5×10^{-6} seconds after detonation of the explosive of the shaped charge. Jet 51 is forming behind projectile 50 and kinetic energy from the explosion is being passed to projectile 50. FIG. 5C shows further formation of the jet approximately 12×10^{-6} seconds after detonation. Projectile 50 remains at the front end of the jet.

[0046] Finally FIG. 5D shows further formation of jet 51 and the projectile 50 approximately 16×10^{-6} seconds after detonation. Comparing FIGS. 5C and 5D it can be seen that the length of the jet is increasing. It can also be seen that the projectile is further away from the front of the jet in FIG. 5D than in FIG. 5C. This shows that the projectile has greater velocity than the jet and will therefore have a greater range than the jet. It should be noted that none of FIG. 5A to 5D include velocity profiles for either the jet or liner material. Typical velocity profiles for the jet and projectile are shown in FIGS. 3 and 4.

[0047] In some embodiments the liner may be replaced by a ballistic disk as shown in FIG. 6. Ballistic disks in a ballistic disk/shaped charge combination have previously been used as penetrating and perforating devices. Ballistic disks can be formed into projectiles by the detonation of the shaped charge. In the embodiment shown in FIG. 6 when

the shaped charge is detonated the ballistic disk impacts on the rear of the projectile and provides kinetic energy to the projectile.

[0048] In FIG. 6 a ballistic disk is used to propel the projectile. In this case, the detonation of the shaped charge causes the charge to shoot out a ballistic disk. This ballistic disk in turn impacts the rear end of the projectile which is provided with a heat resistant material, and more preferably a highly dense material (such as depleted uranium) at the rear of the preformed projectile. Because the projectile is a free moving object, the collision with the ballistic disk moves both the projectile and the disk along the original axis of movement of the ballistic disk.

[0049] FIG. 7 shows a projectile with a jet trap (see below) and an oversized shaped charge. By using a projectile which is a fraction of the mass of the metal liner of the shaped charge, more of the kinetic energy from the detonation can be transferred to the projectile to enable the projectile to reach hyper-velocity speeds in excess of 6,000 metres per second.

[0050] In one embodiment the jet trap is a frusto-conical aperture with its largest diameter at the rear of the projectile. The surrounding material is preferably formed of a heat resistant high-density material such as depleted uranium. The jet trap is designed as a means of transferring the kinetic energy of the resulting jet resulting from the detonation of the shaped charge. By increasing the surface area at the rear of the projectile, which interacts with a jet, it is possible to prolong the impact time and increase the surface area of interaction between the jet and the projectile. At its simplest, a jet trap is simply a conical or frusto-conical indent in the rear of the projectile.

[0051] Preferably a diameter of the mouth of the jet trap is marginally greater in size than the diameter of the jet produced by the detonation of the shaped charge at the point where it first interacts with a projectile.

[0052] The surface area of the interior of the jet trap may be increased by suitably shaping the internal surface of that jet trap. In one embodiment the surface area can be increased by forming a type of star indent to thereby increase the jet trap surface area.

[0053] By appropriately shaping the interior of the jet trap it is possible to create the effect of rifling, and hence spinning of the projectile.

[0054] Preferably the inner surface of the jet trap can be aligned so that when impact occurs with a jet from the detonation of the shaped charge, the jet touches a surfaces that imposes a centrifugal effect on the projectile.

[0055] Because of the rate of transfer of kinetic energy to the projectile, it is possible to design artillery pieces that can be much smaller than conventional artillery, and yet achieve the same killing power or same range as a much larger conventional gun. In addition, greater distances can be achieved as a result of greater speed. This also results in a flatter trajectory and thus it will be possible to use the high velocity bullet concept to provide a cheap alternative to missiles or rockets, whilst covering the same range or impact velocity. It may also be possible to make use of this invention to assist in the launch of unmanned satellites, or probes into the upper atmosphere provided they are capable

of withstanding the substantial g-fores associated with the launch velocity. In such cases, a projectile containing a rocket or multiple shaped charges would be launched at high velocity and then accelerated to escape velocity by use of a rocket or other propulsion means.

[0056] The foregoing describes the invention including preferred forms thereof. Alterations and modifications as will be obvious to those skilled in the art are intended to be incorporated within the scope hereof as defined by the accompanying claims.

1. A shaped charge and projectile combination including:
 - a projectile
 - a shaped charge of high explosive material including a cavity in an external face of the charge, shaped to axially concentrate explosive upon detonation of the shaped charge towards the projectile, and
 - a metal liner between the shaped charge and the projectile, to form a jet of liner material on detonation of the shaped charge to impact the rear of and propel the projectile.
2. A shaped charge and projectile combination as claimed in claim 1 wherein the shaped charge is housed in a casing forming a cartridge.
3. A shaped charge and projectile combination as claimed in claim 2 wherein the projectile is retained within the cavity in the shaped charge.
4. A shaped charge and projectile combination as claimed in any one of claims 1 to 3 wherein the projectile has a ballistic shape with a front end and a rear end and wherein at least the rear end includes a layer of temperature resistant material.
5. A shaped charge and projectile combination as claimed in claim 4 wherein the temperature resistant material is one of the group of carbon, titanium, tungsten, ceramics, steel, uranium or depleted uranium.
6. A shaped charge and projectile combination as claimed in any one of claims 1 to 5 wherein the projectile includes an aperture facing the liner of the shaped charge.
7. A shape charge and projectile combination as claimed in any one of claims 1 to 6 wherein the projectile includes stabilisation means.
8. A shaped charge and projectile in combination as claimed in claim 7 wherein the stabilisation means includes external wings or fins.
9. A shaped charge and projectile in combination as claimed in claim 7 wherein the stabilisation means includes dimples or grooves.
10. A shaped charge and projectile in combination as claimed in claim 7 wherein the stabilisation means includes means to interact with rifling on the inside of a barrel of a weapon.
11. A shaped charge and projectile combination as claimed in any one of claims 1 to 10 wherein the projectile is a bullet.
12. A shaped charge and projectile combination as claimed in any one of claims 1 to 10 wherein the projectile is a shell.
13. A shaped charge and projectile combination as claimed in any one of claims 1 to 12 wherein the cavity in the shaped charge has a concave shape.

14. A shaped charge and projectile combination as claimed in any one of claims 1 to 12 wherein the cavity in the shaped charge has an ovaloid shape.

15. A shaped charge and projectile combination as claimed in any one of claims 1 to 12 wherein the cavity in the shaped charge has a cylindrical shape.

16. A shaped charge and projectile combination as claimed in any one of claims 1 to 15 wherein the explosive of the shaped charge is arranged to be detonated by electrical ignition.

17. A shaped charge and projectile in combination as claimed in any one of claims 1 to 15 wherein the explosive of the shaped charge is arranged to be detonated by a firing pin.

18. A shaped charge and projectile in combination as claimed in any one of claims 1 to 15 wherein the explosive of the shaped charge is arranged to be detonated by laser ignition.

19. A shaped charge and projectile in combination as claimed in any one of the preceding claims wherein the projectile has a diameter which is less than the widest cross-section of the cavity in the shaped charge.

20. A shaped charge and projectile in combination as claimed in any one of the preceding claims wherein the liner is a ballistic disk.

21. A shaped charge and projectile in combination including:

a projectile,

a body of a high explosive material forming a charge and including an internal cavity open to one end of the charge to axially concentrate explosive force upon detonation of the shaped charge towards the rear face of the projectile, and

a metal layer lining the interior of the cavity in the shaped charge.

22. A shaped charge and projectile combination as claimed in claim 21 wherein the shaped charge is housed in a casing forming a cartridge.

23. A shaped charge and projectile combination as claimed in claim 22 wherein the projectile is retained within the cavity in the shaped charge.

24. A shaped charge and projectile combination as claimed in any one of claims 21 to 23 wherein the projectile has a ballistic shape with a front end and a rear end and wherein at least the rear end includes a layer of temperature resistant material.

25. A shaped charge and projectile combination as claimed in claim 24 wherein the temperature resistant material is one of the group of carbon, titanium, tungsten, ceramics, steel, uranium or depleted uranium.

26. A shaped charge and projectile combination as claimed in any one of claims 21 to 25 wherein the projectile includes an aperture facing the liner of the shaped charge.

27. A shaped charge and projectile combination as claimed in any one of claims 21 to 26 wherein the projectile includes stabilisation means.

28. A shaped charge and projectile in combination as claimed in claim 27 wherein the stabilisation means includes external wings or fins.

29. A shaped charge and projectile in combination as claimed in claim 27 wherein the stabilisation means includes dimples or grooves.

30. A shaped charge and projectile in combination as claimed in claim 27 wherein the stabilisation means includes means to interact with rifling on the inside of a barrel of a weapon.

31. A shaped charge and projectile combination as claimed in any one of claims 21 to 30 wherein the projectile is a bullet.

32. A shaped charge and projectile combination as claimed in any one of claims 21 to 30 wherein the projectile is a shell.

33. A shaped charge and projectile combination as claimed in any one of claims 21 to 32 wherein the cavity in the shaped charge has a concave shape.

34. A shaped charge and projectile combination as claimed in any one of claims 21 to 32 wherein the cavity in the shaped charge has an ovaloid shape.

35. A shaped charge and projectile combination as claimed in any one of claims 21 to 32 wherein the cavity in the shaped charge has a cylindrical shape.

36. A shaped charge and projectile combination as claimed in any one of claims 21 to 35 wherein the explosive of the shaped charge is arranged to be detonated by electrical ignition.

37. A shaped charge and projectile in combination as claimed in any one of claims 21 to 35 wherein the explosive of the shaped charge is arranged to be detonated by a firing pin.

38. A shaped charge and projectile in combination as claimed in any one of claims 21 to 35 wherein the explosive of the shaped charge is arranged to be detonated by laser ignition.

39. A shaped charge and projectile in combination as claimed in any one of claims 21 to 38 wherein the projectile has a diameter which is less than the widest cross-section of the cavity in the shaped charge.

40. A shaped charge and projectile in combination as claimed in any one of claims 21 to 39 wherein the liner is a ballistic disk.

41. A method of propelling a projectile including:

providing a projectile,

providing a shaped charge of high explosive material including a cavity in an external face of the charge, the cavity shaped to axially concentrate explosive upon detonation of the shaped charge towards the projectile,

providing a metal liner between the shaped charge and the projectile, and

detonating the shaped charge at an end opposite the cavity to form a jet of liner material, and focus the jet on the rear of the projectile so that at least a portion of the kinetic energy of the jet is transferred to the projectile to propel the projectile.