

US 20060118309A1

(19) **United States**

(12) **Patent Application Publication**
Head

(10) **Pub. No.: US 2006/0118309 A1**

(43) **Pub. Date: Jun. 8, 2006**

(54) **SEABED INSTALLATION APPARATUS**

(52) **U.S. Cl. 166/358**

(76) **Inventor: Philip Head, Berks (GB)**

Correspondence Address:
THE FIRM OF KARL F ROSS
5676 RIVERDALE AVENUE
PO BOX 900
RIVERDALE (BRONX), NY 10471-0900 (US)

(57) **ABSTRACT**

(21) **Appl. No.: 10/523,137**

(22) **PCT Filed: Jul. 23, 2003**

(86) **PCT No.: PCT/GB03/03172**

(30) **Foreign Application Priority Data**

Jul. 23, 2002 (GB) 0217059.5
Oct. 19, 2002 (GB) 0224410.1

Publication Classification

(51) **Int. Cl.**
E21B 7/12 (2006.01)

A seabed installation apparatus comprising a soil penetration means (2), a deployment line (4) from which the soil penetration means is suspended, a mooring line (6) attached to the soil penetration means, the mooring line being releasably secured to the deployment line. The mooring line (6) is shorter than the deployment line (4). The deployment line (4) supplies power to the soil penetration means (2) and is releasably attached to the soil penetration means. The mooring line (6) is releasably secured to the deployment line substantially along the length of the mooring line. The soil penetration means includes an auger and fins capable of resisting torque generated by the action of the soil penetration means. Measurement and control means capable of assessing the pressure characteristics of the soil penetration means and altering the action of the soil penetration means in response to the penetration characteristics are included.

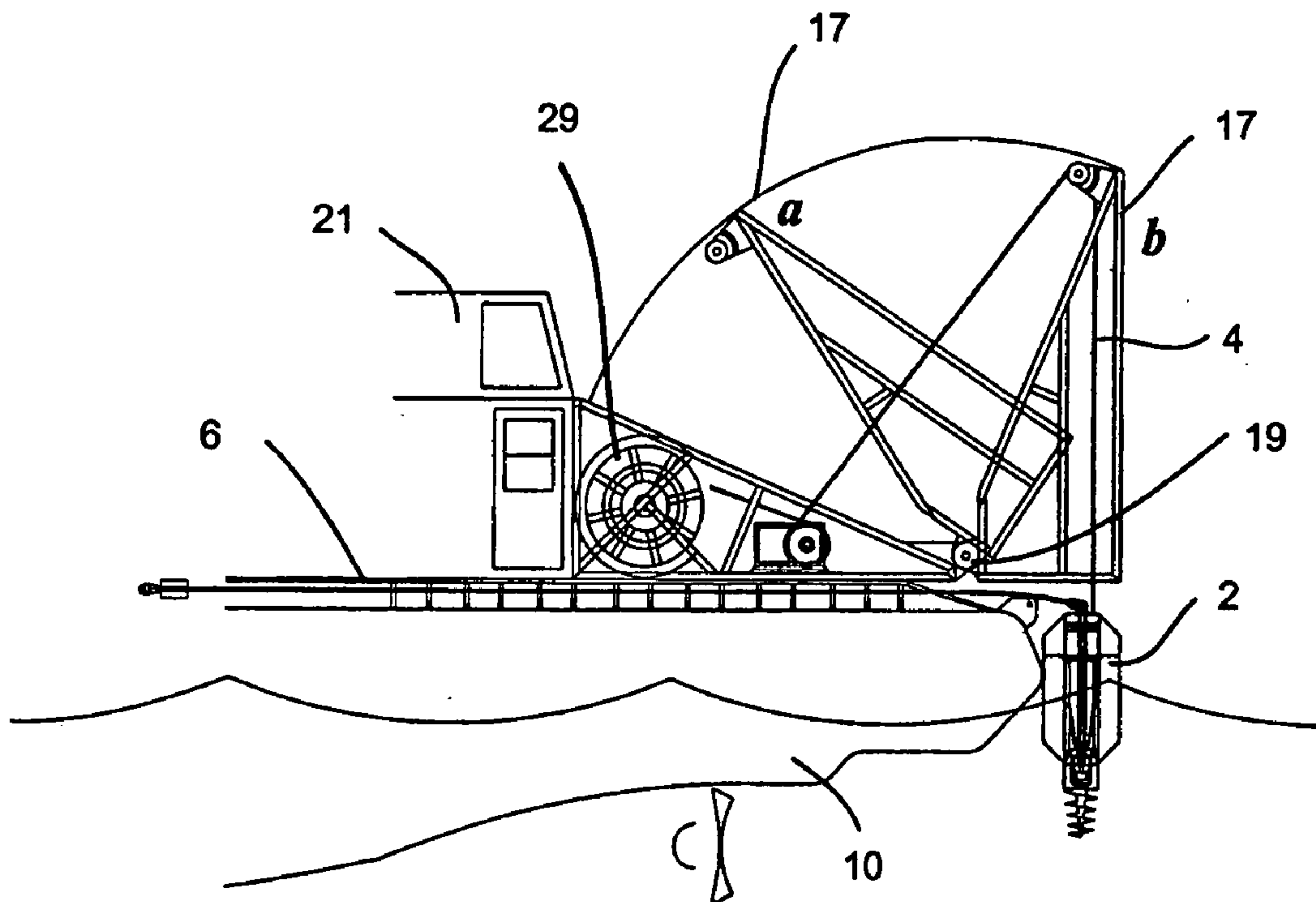

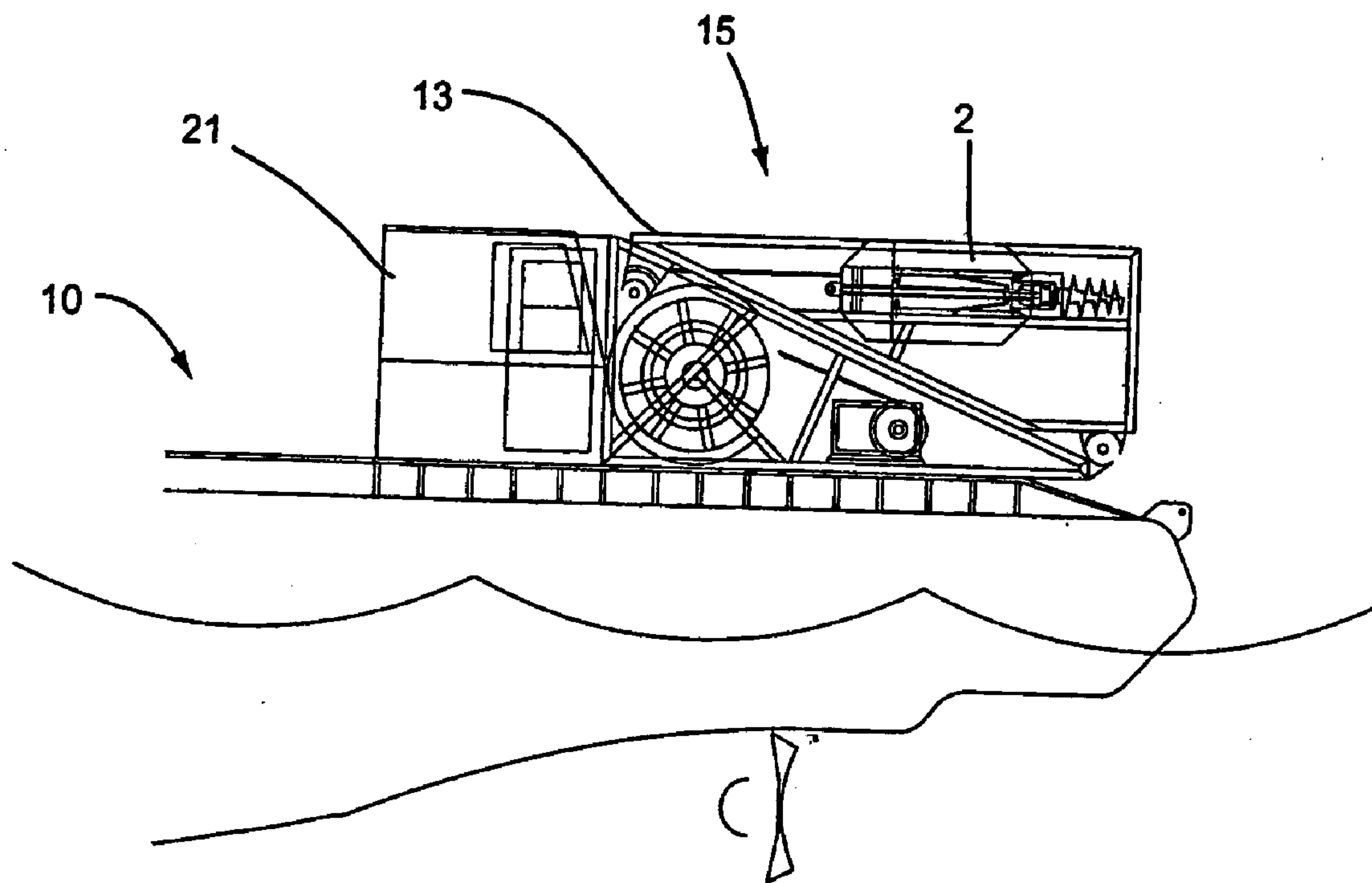

Fig. 1

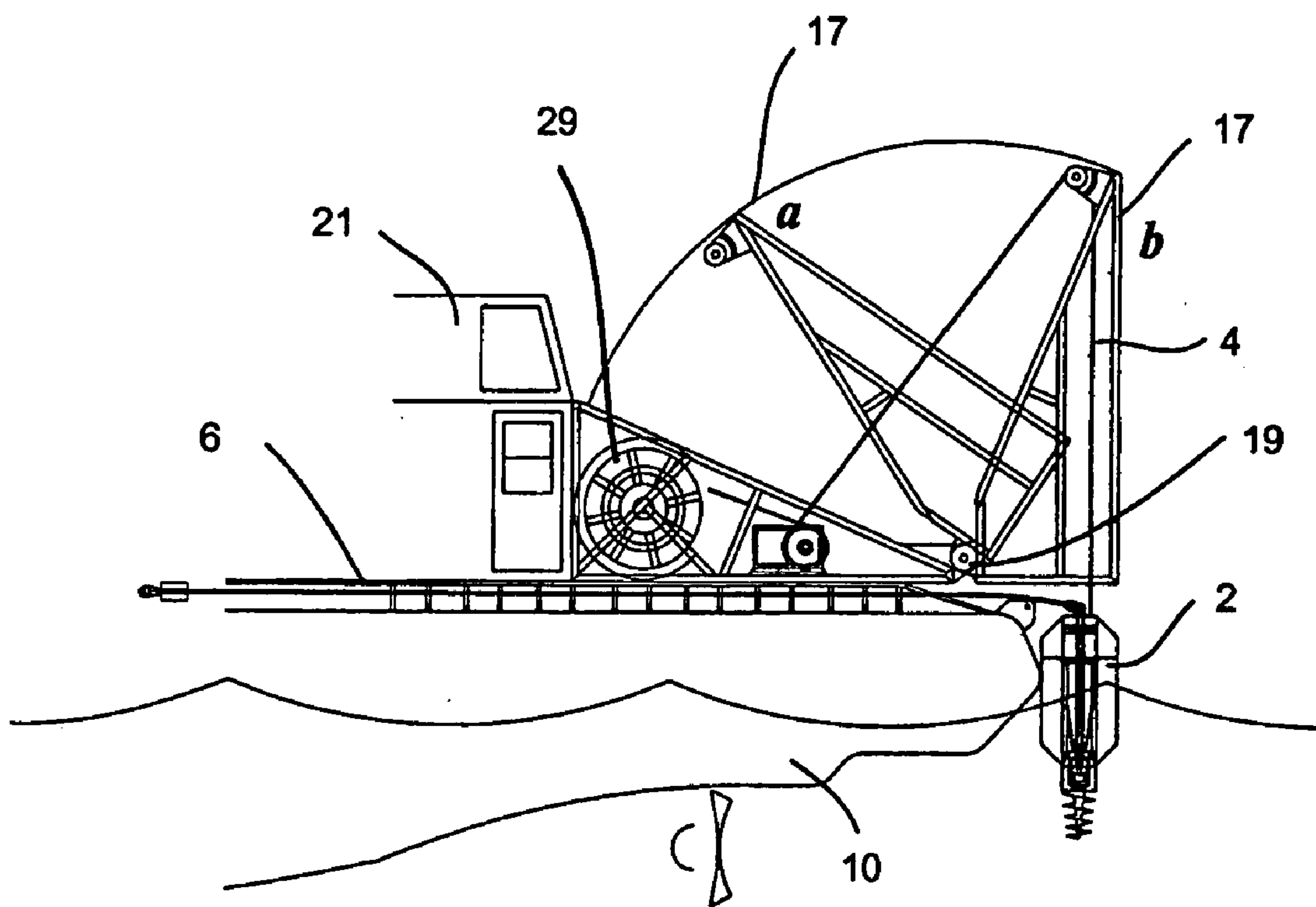

Fig. 2

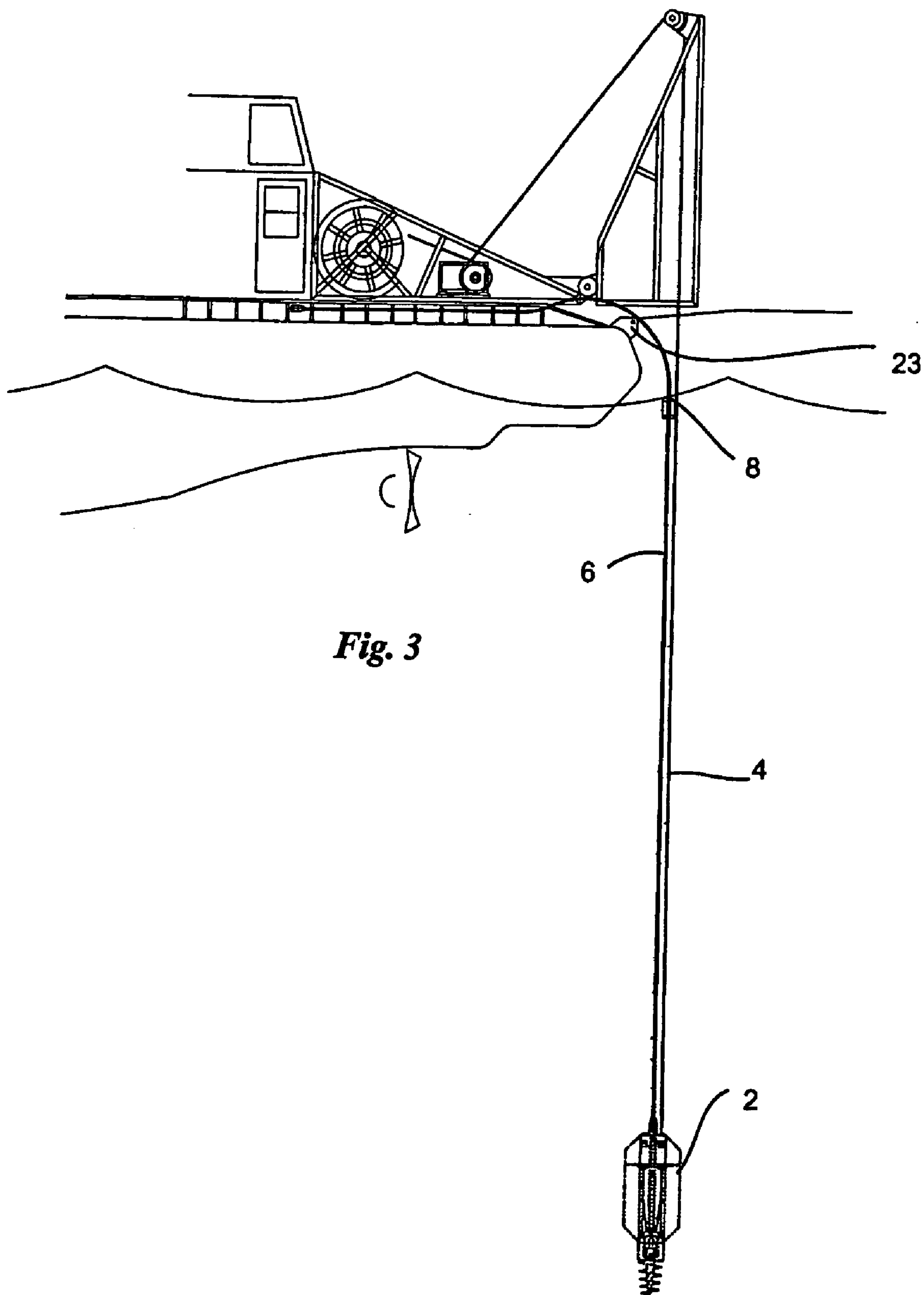
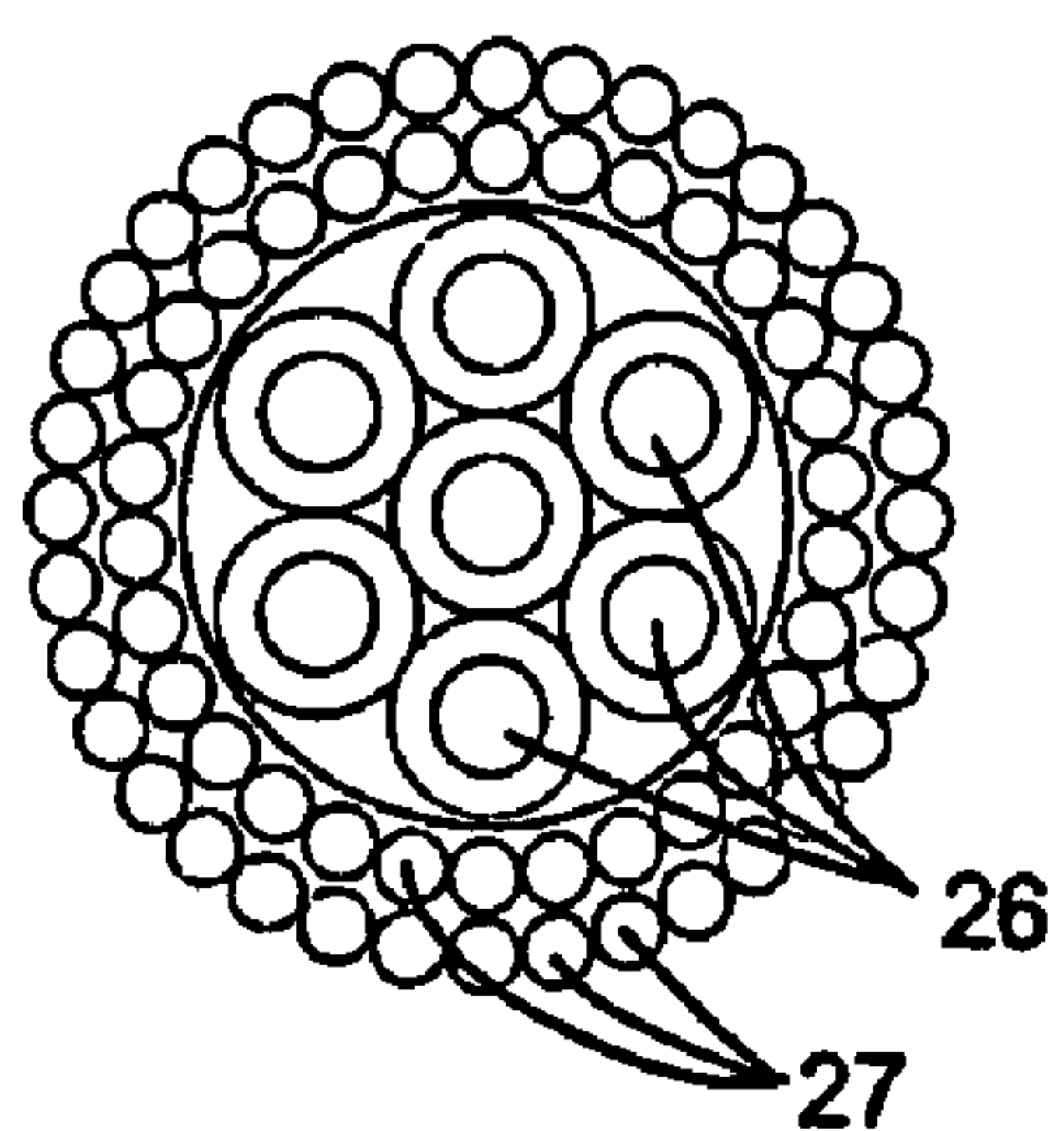
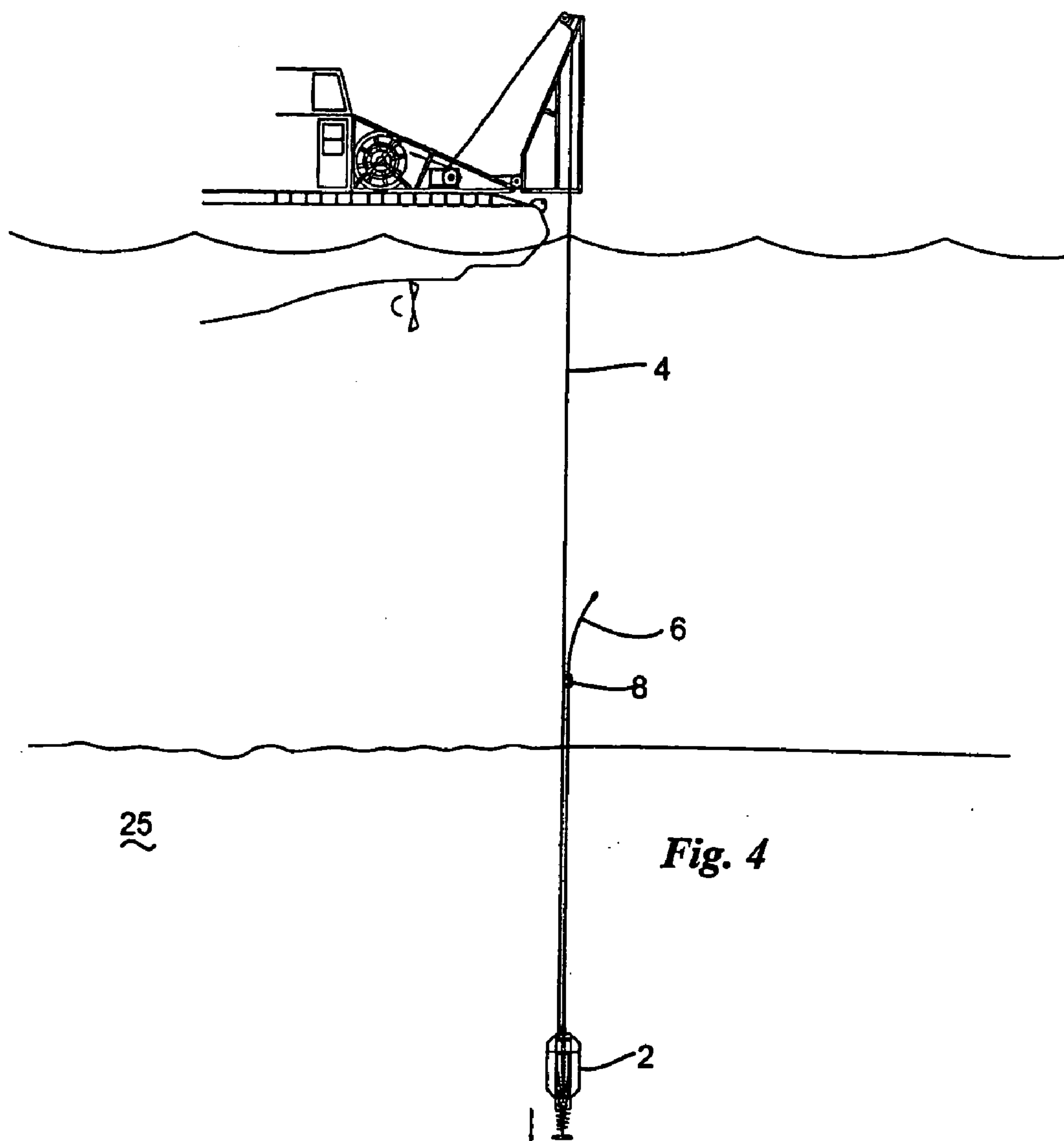

Fig. 3



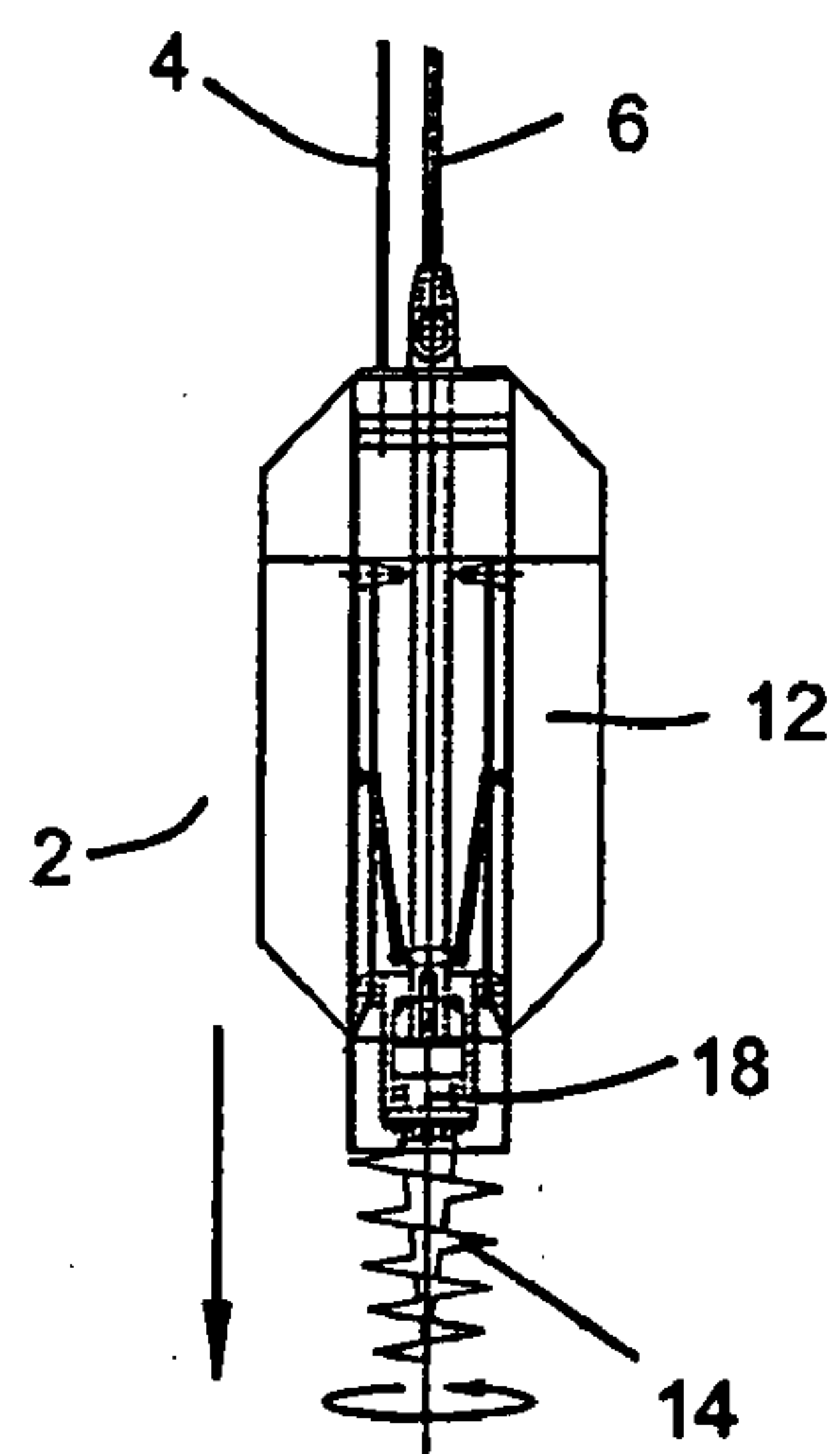

Fig. 6a

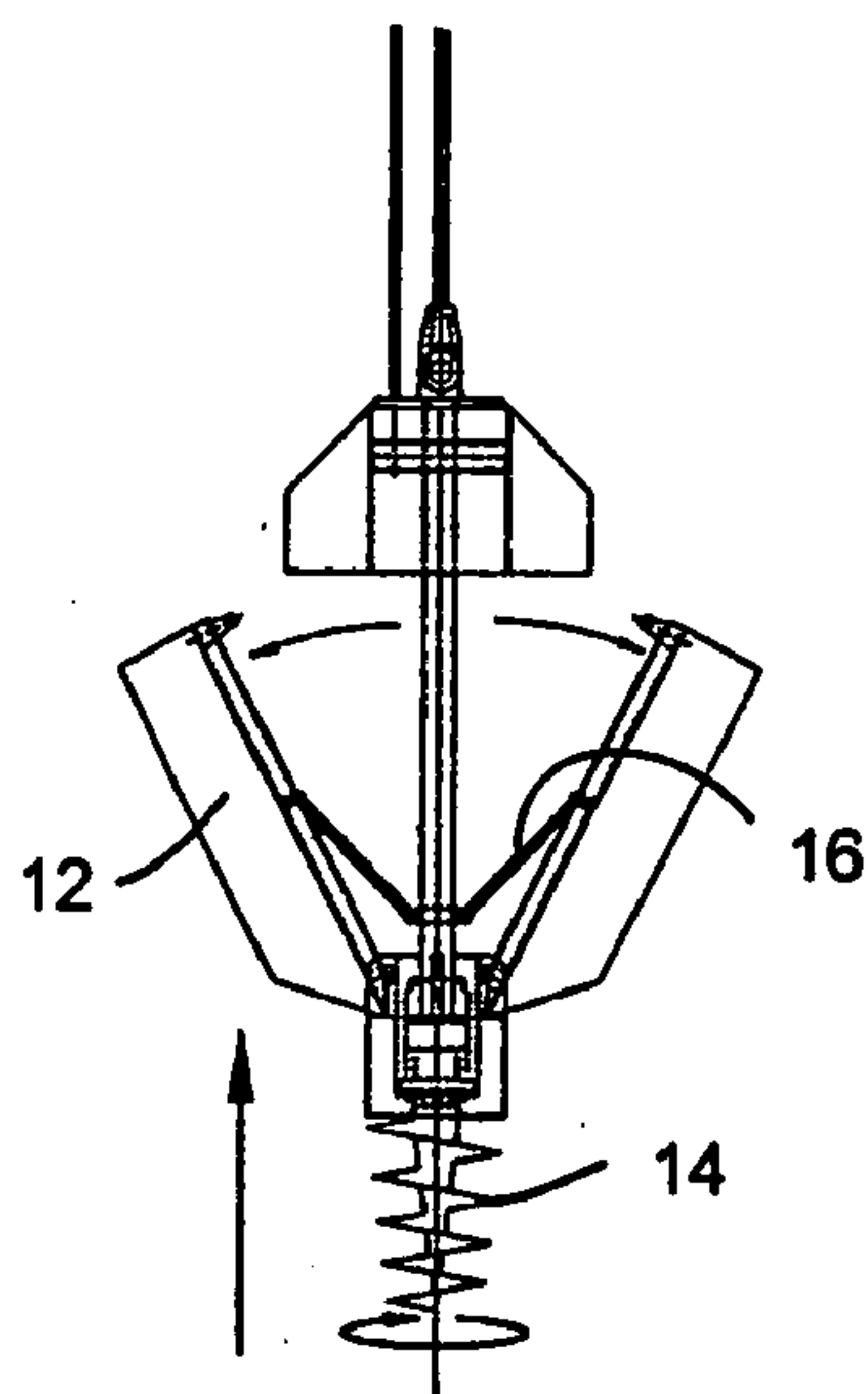

Fig. 6b

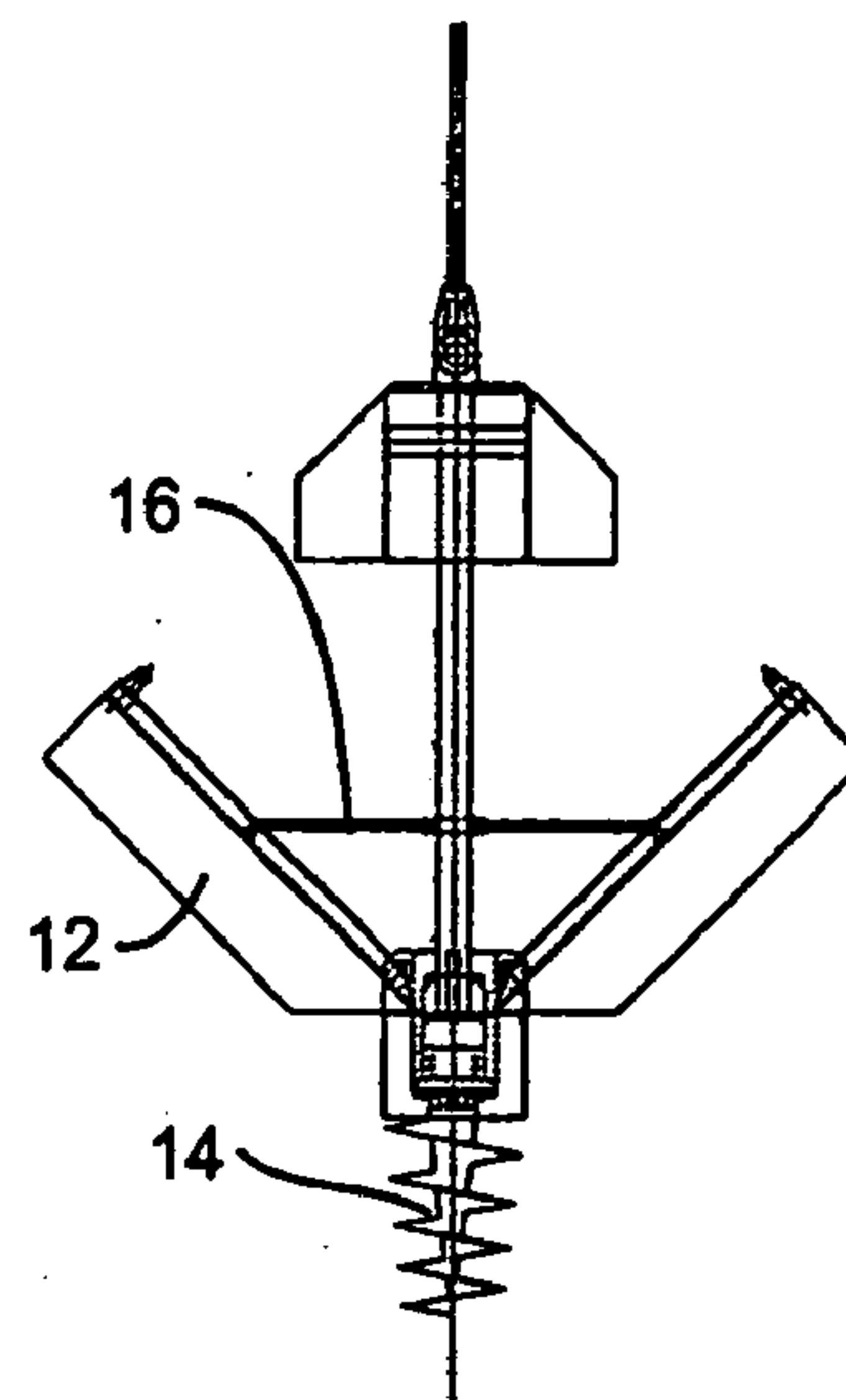

Fig. 6c

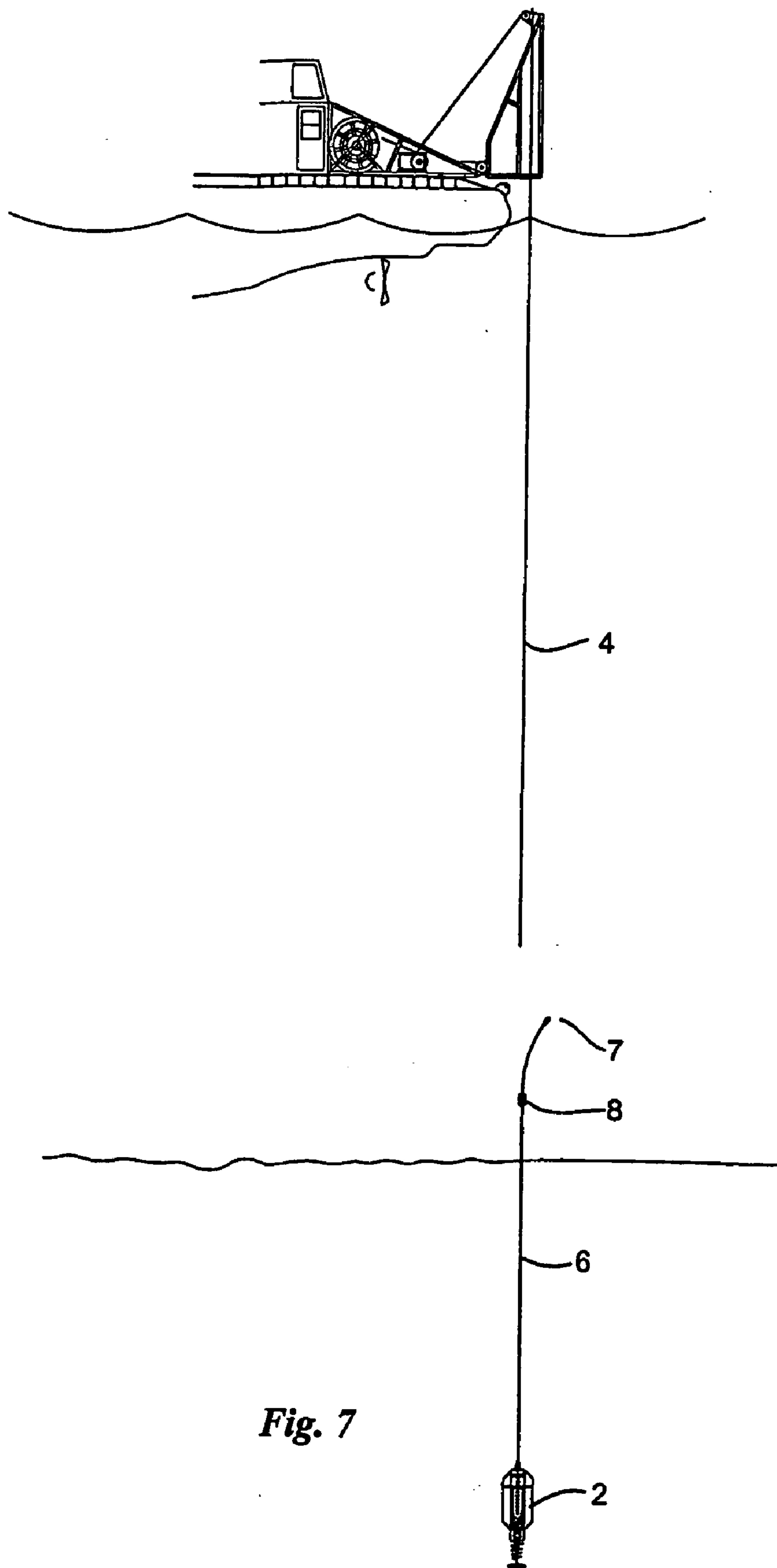
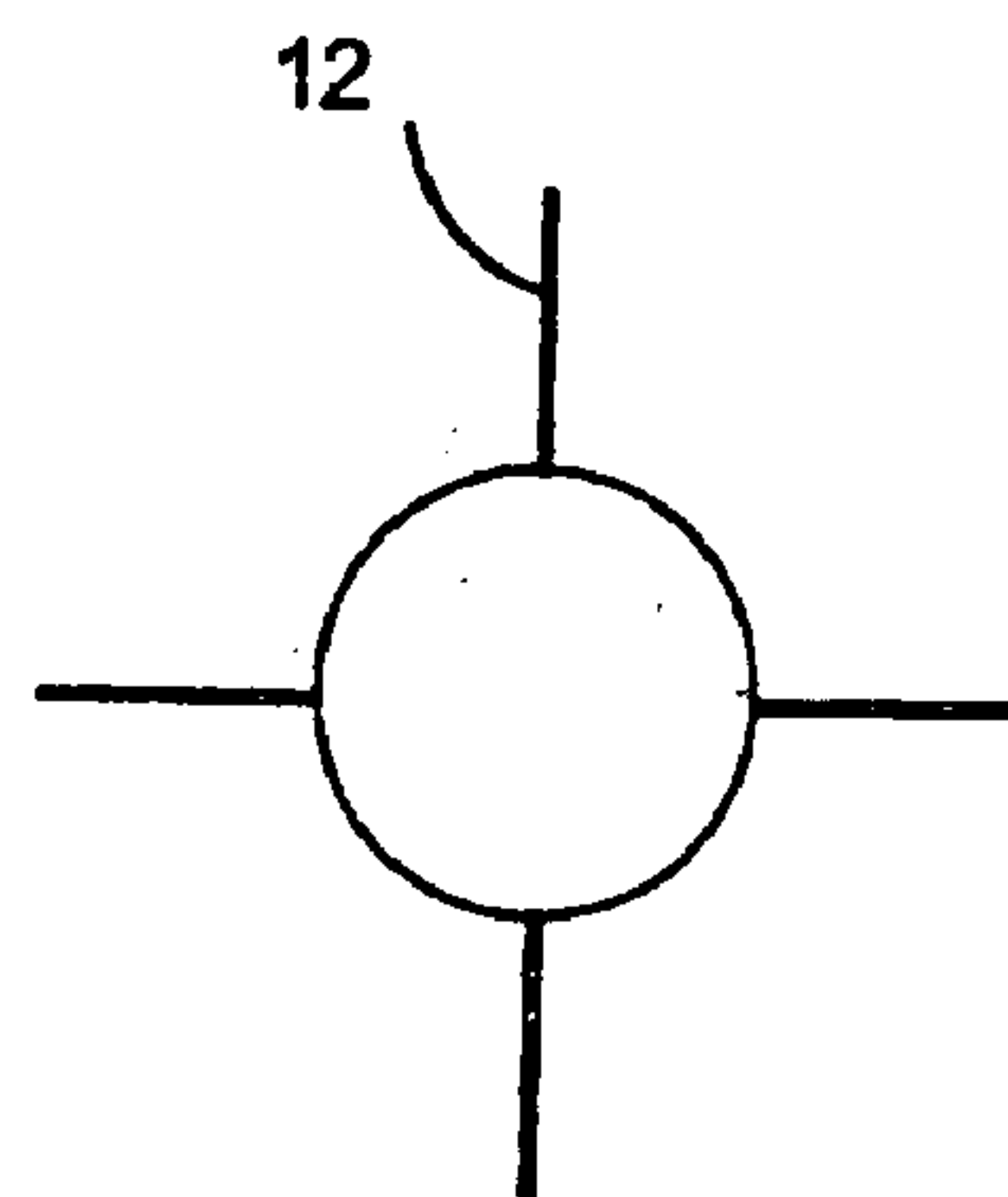
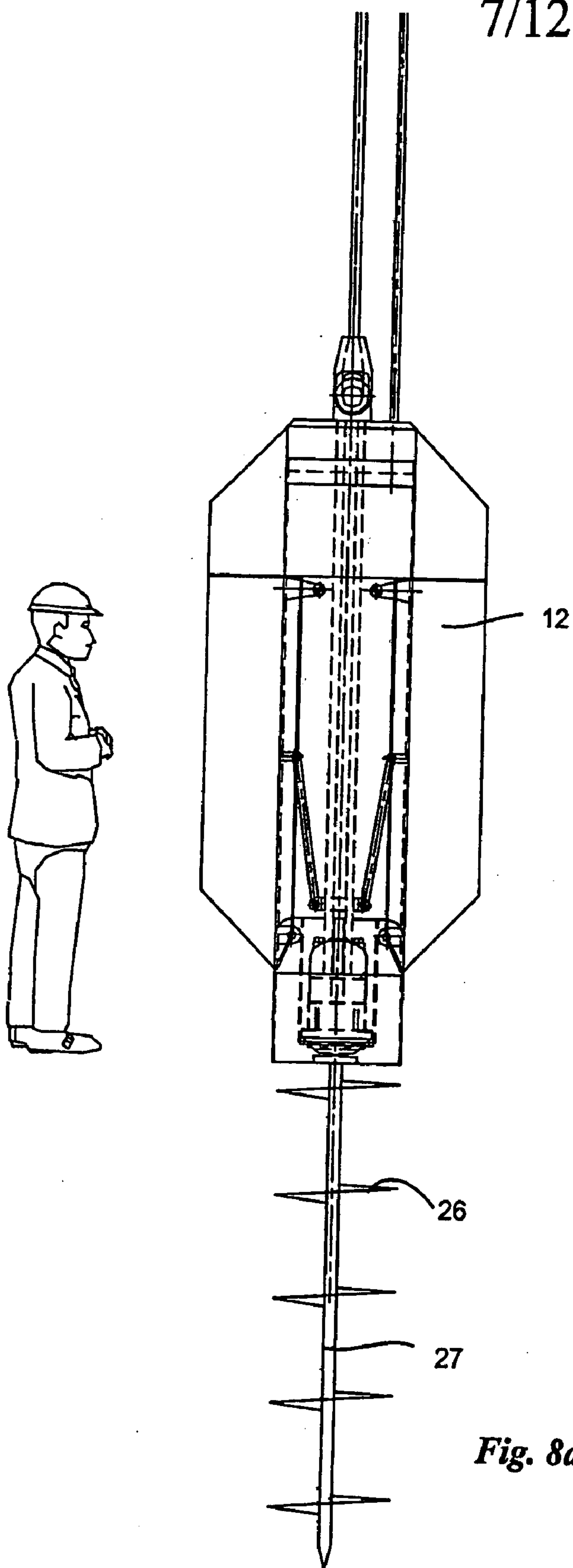

Fig. 7

7/12



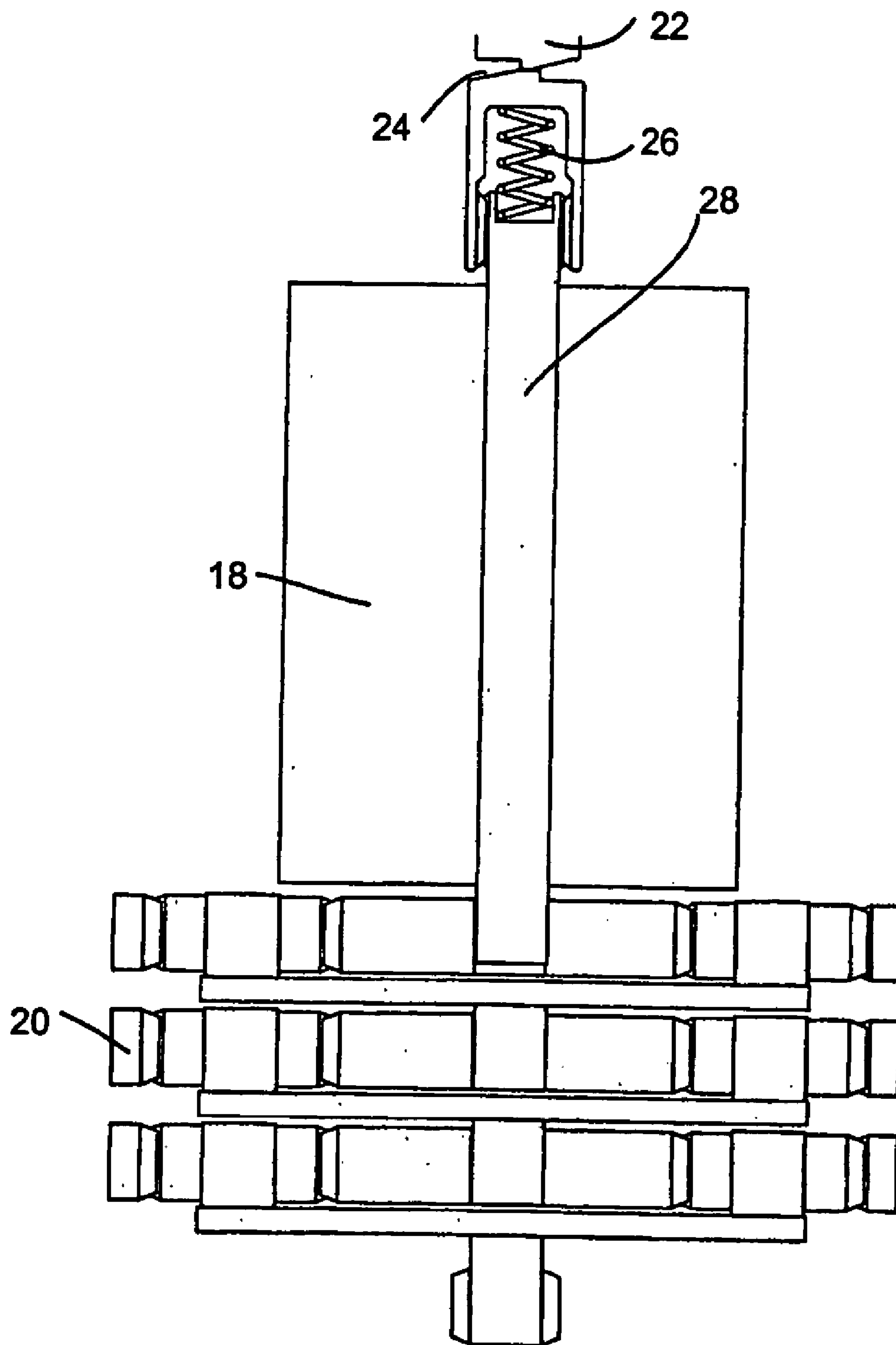

Fig. 9

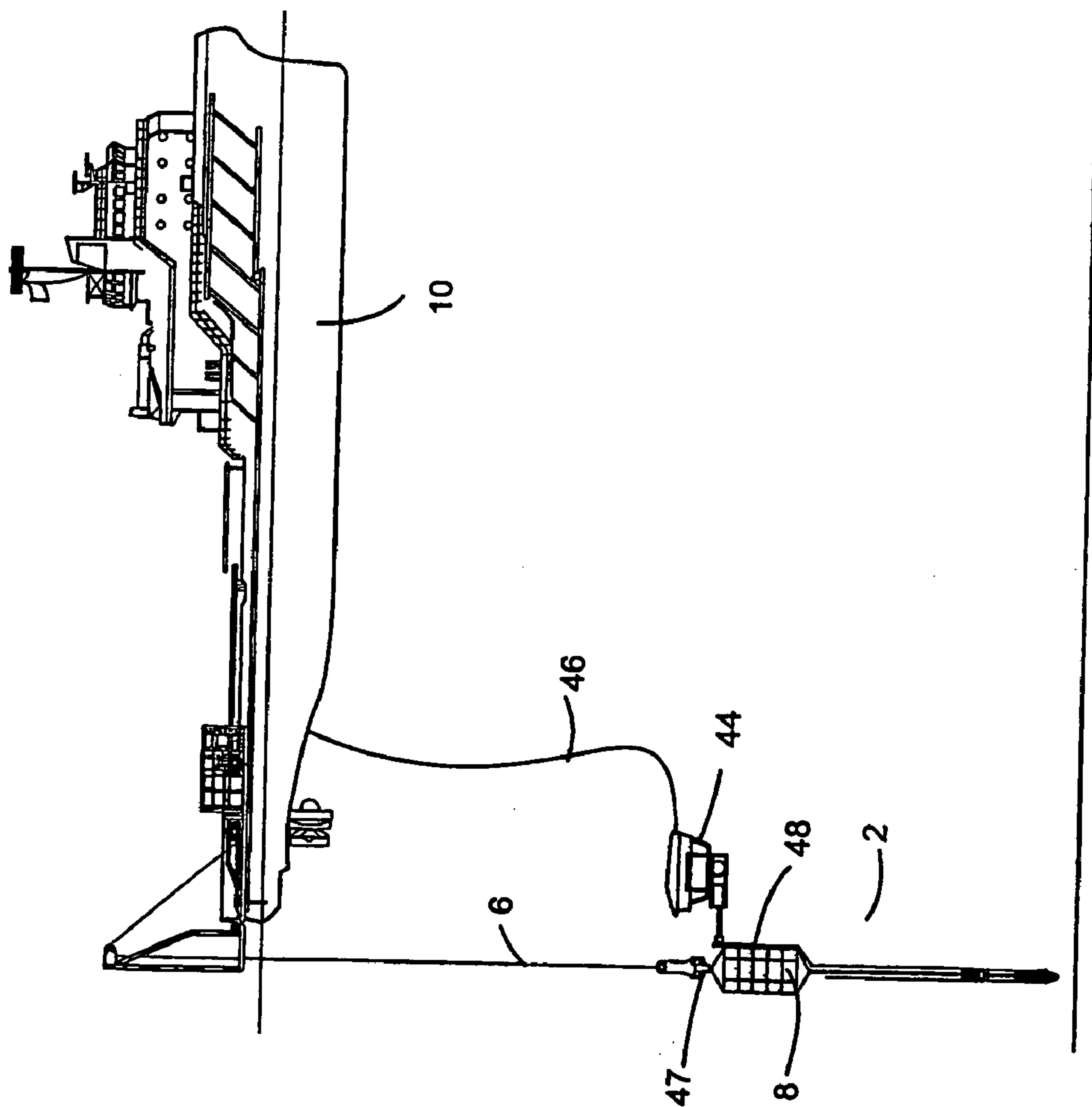

Fig. 10a

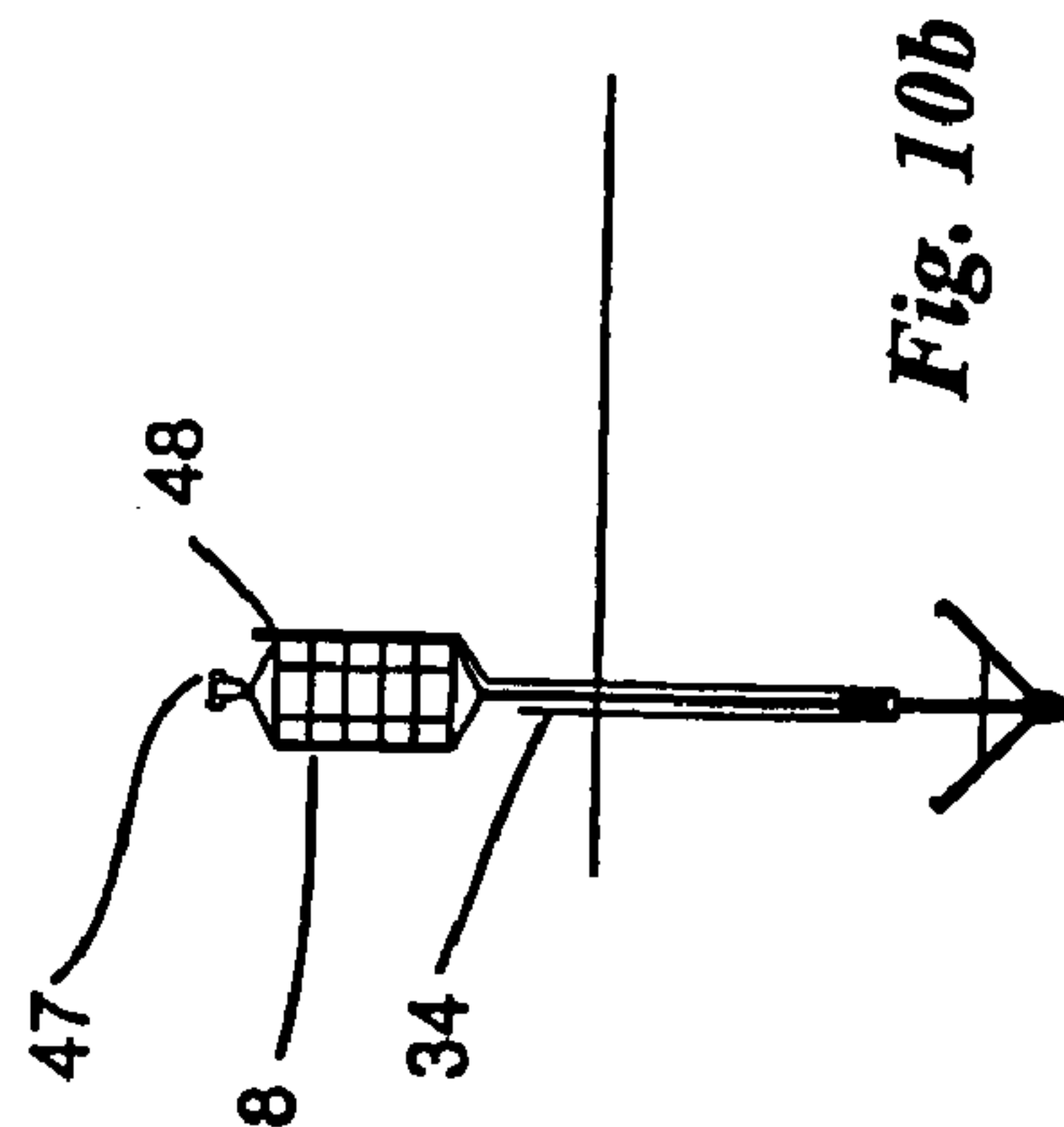

Fig. 10b

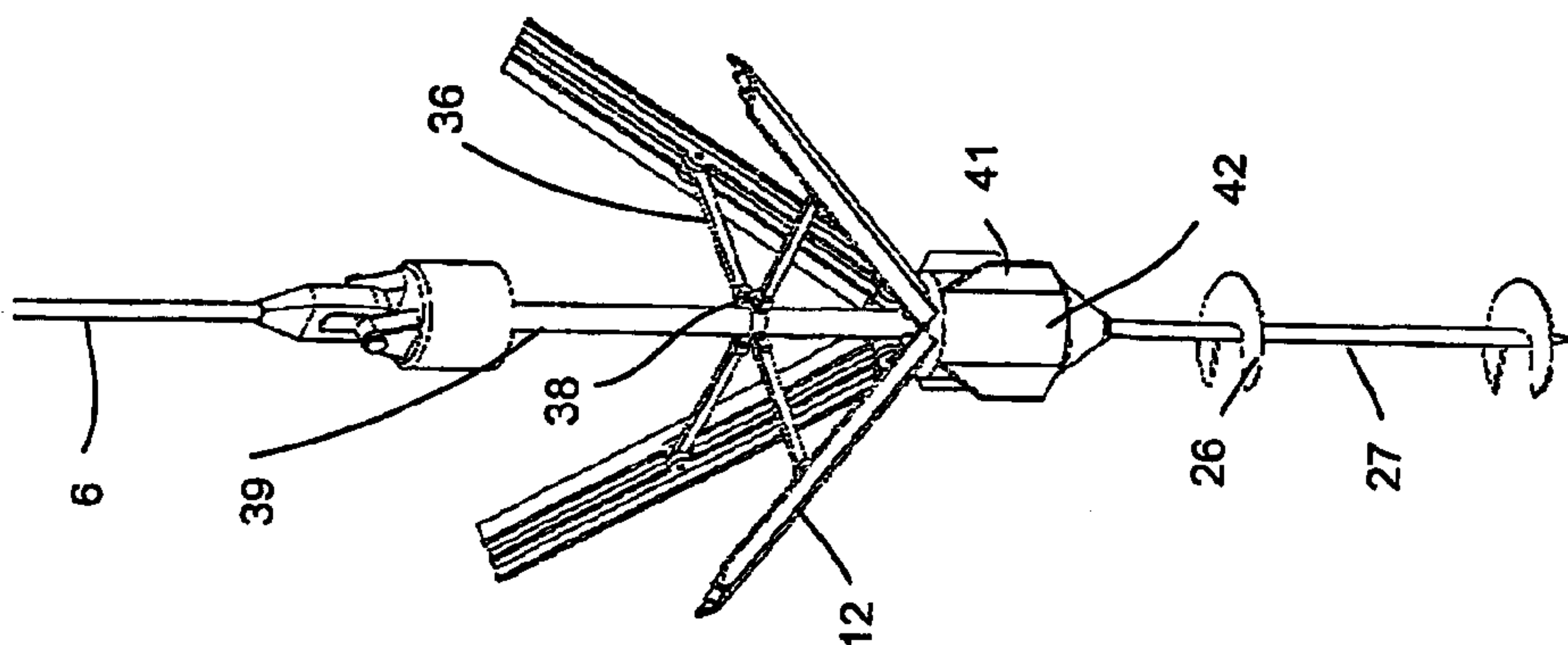

Fig. 12

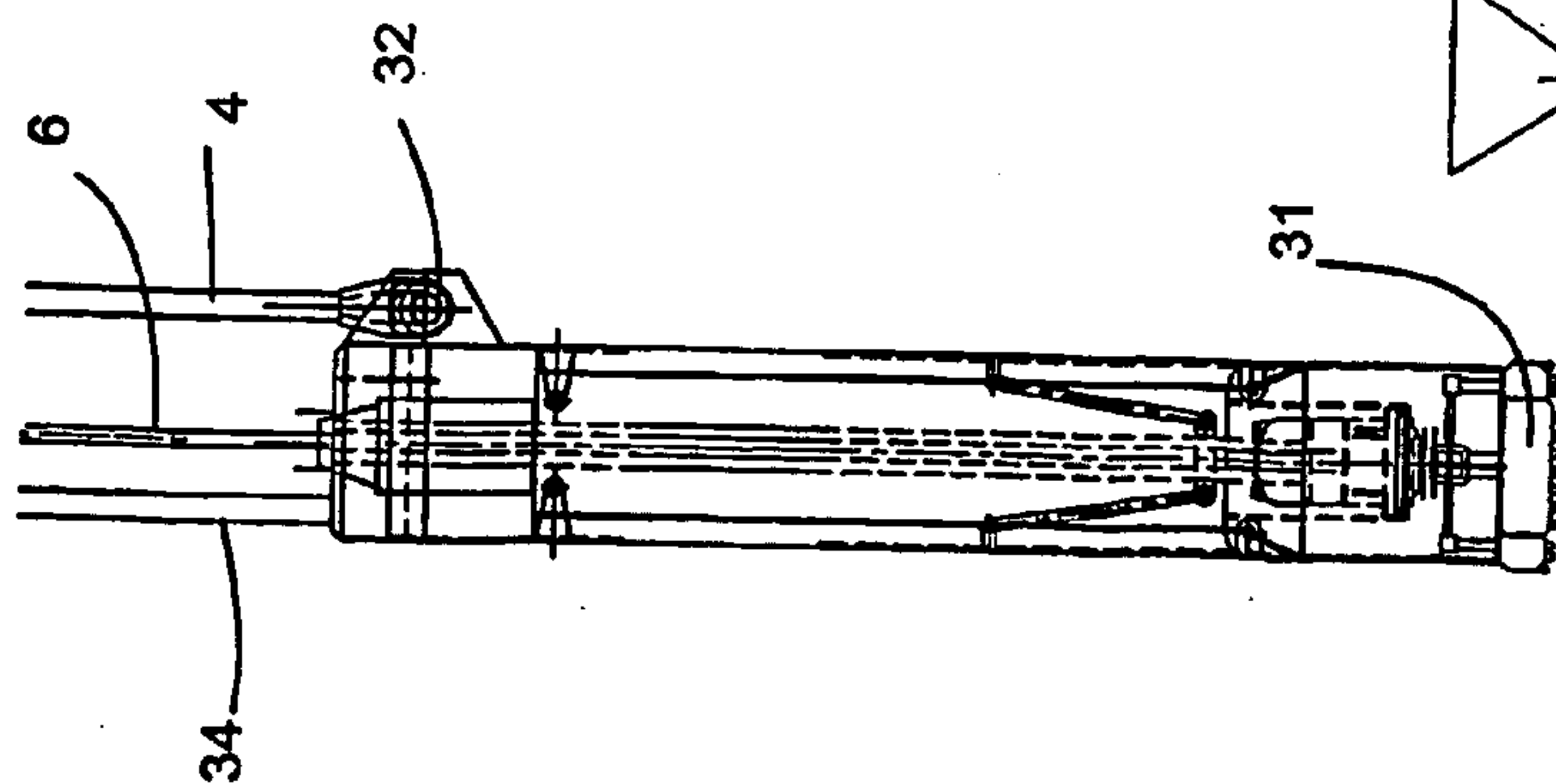

Fig. 11a

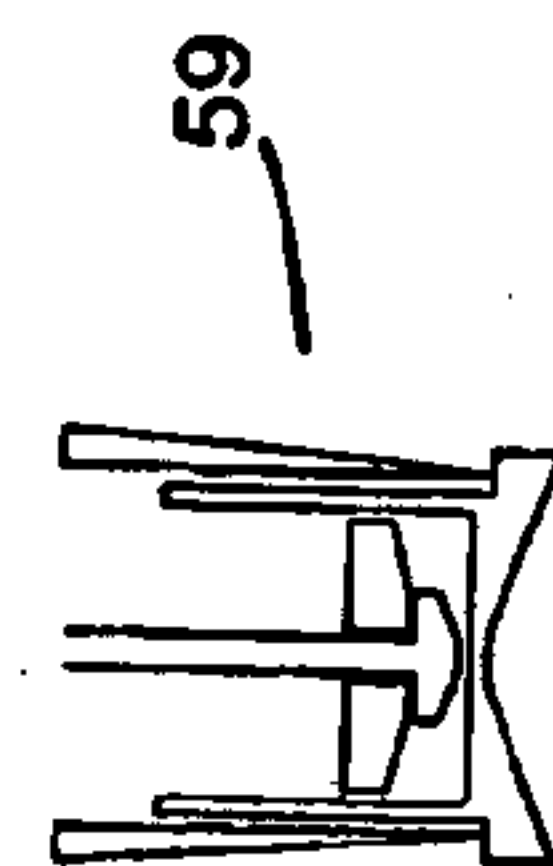

Fig. 11c

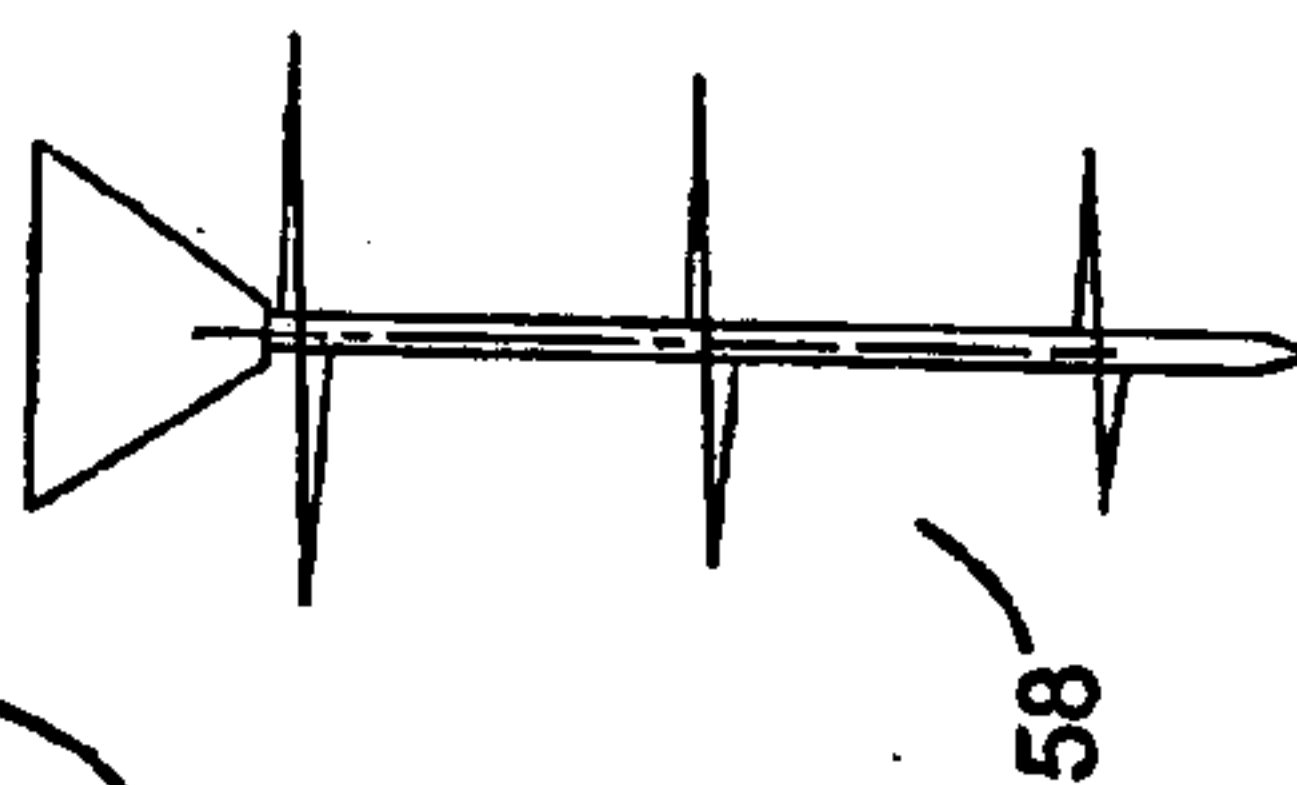

Fig. 11b

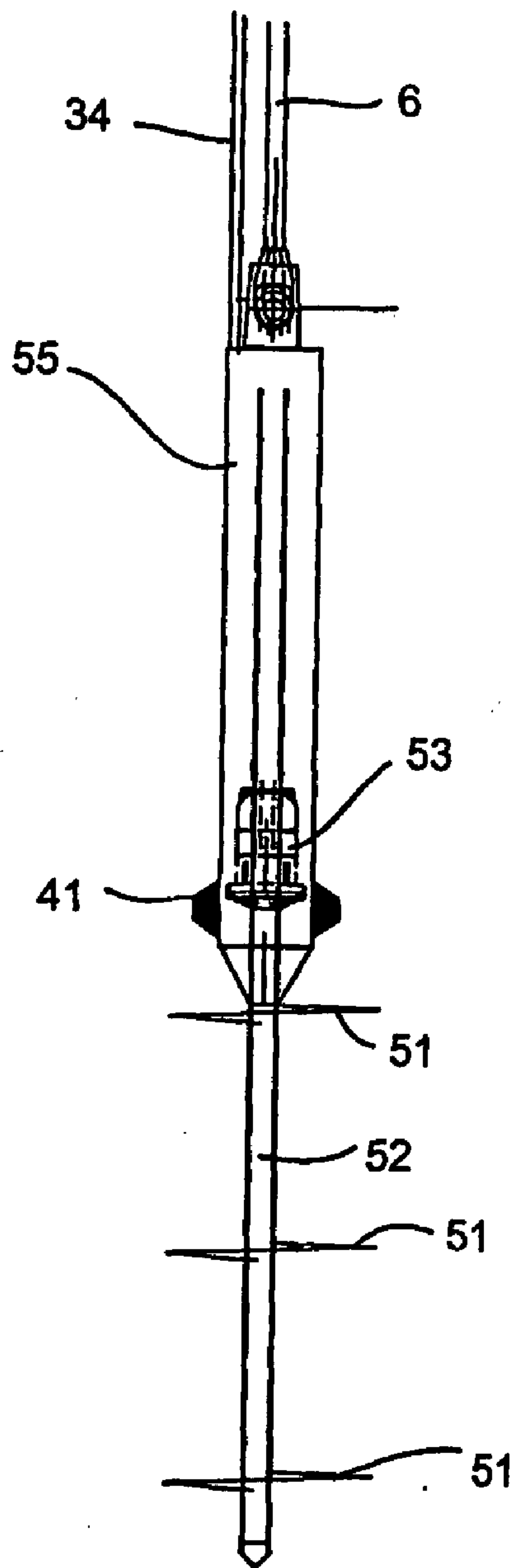

Fig. 13a

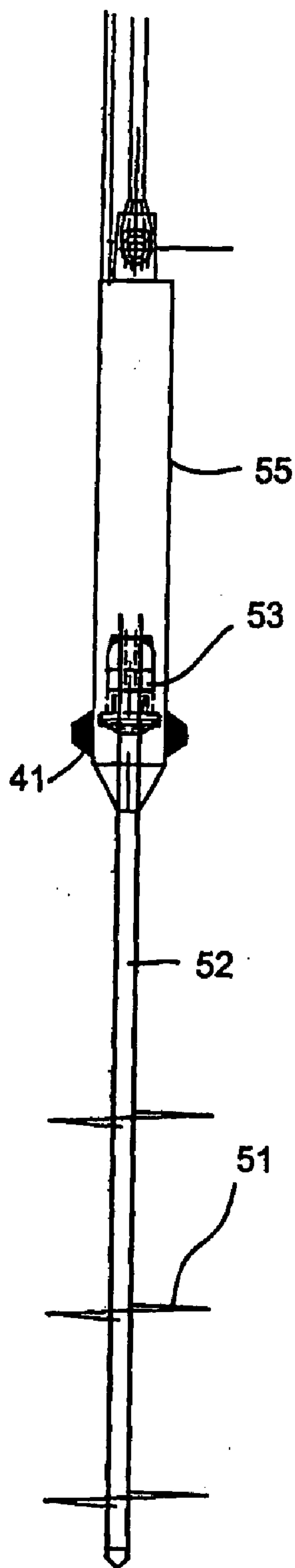

Fig. 13b

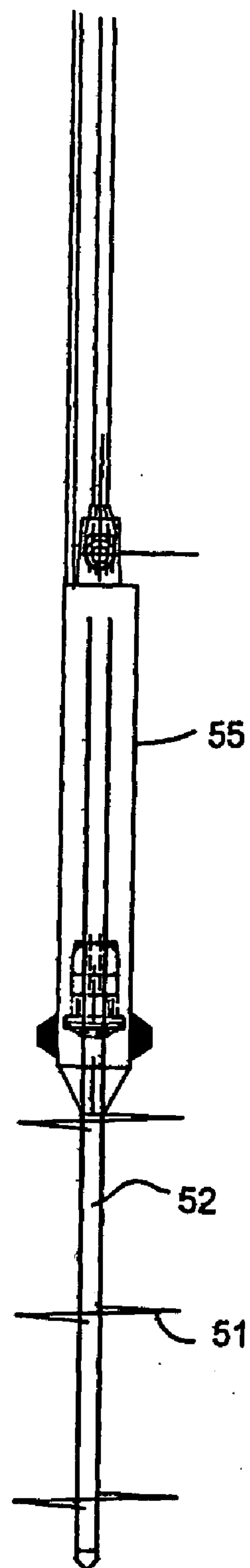

Fig. 13c

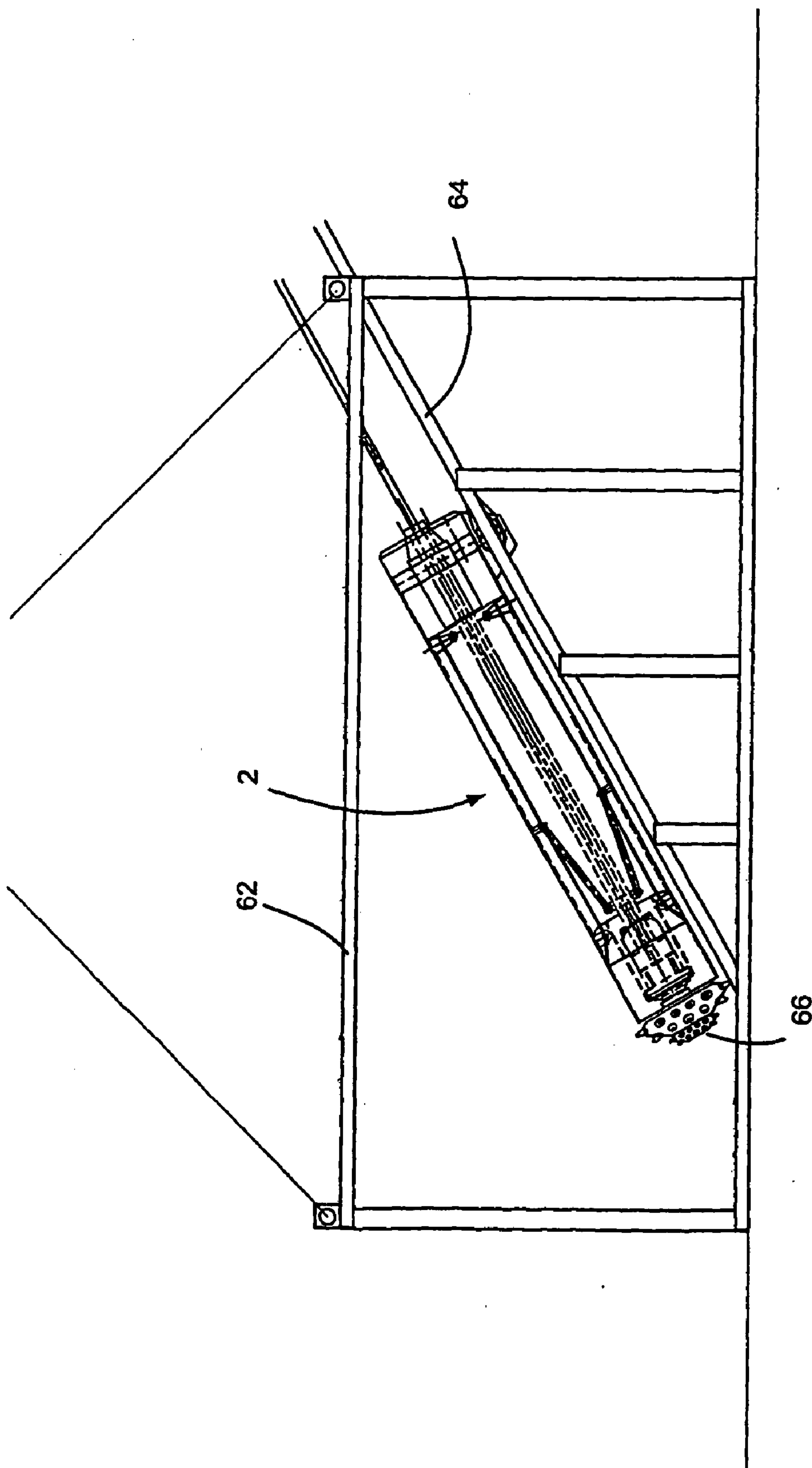

Fig. 14

SEABED INSTALLATION APPARATUS

[0001] The present invention relates to a seabed installation apparatus and methods for its deployment from a vessel.

[0002] The installation may be used for any purpose requiring the installation below the sea bed for example a mooring anchor for ships or other sea going vessels or alternatively it may be used for a means of locating probes or sensors at required depths in the sea bed. Other uses will be apparent to skilled persons.

[0003] For example when laying anchors for a rig in the conventional manner, a supply vessel tows the anchor, chains, and sometimes a polyester mooring line as far out from the rig as possible. The anchor is then dropped, and when it has reached the seabed the rig uses winches to pull upon the anchor by the mooring line. Hopefully the anchor gets a grip and buries itself in the seabed under the weight of the chain and aided by the angles of the anchor's blades, however this process can be very laborious and time consuming. Two opposing mooring lines have to be deployed before they can be tensioned and tested. If one anchor has failed to become embedded, it must be retrieved and re-laid. It can take a rig sometimes seven days or longer to achieve a secure mooring position.

[0004] A common known way of analysing the structure of formation structures below the seabed is to deploy one or more lines of sensors from a ship. The sensor lines or 'streamers' trail behind the ship, and receive sound waves produced by a source transmitted and then reflected or emitted from the seabed, so that deductions of the structure and composition of the formation structure may be made. It is often desirable to cover a wide area in a single pass, so the lines have to be spread of the greatest width possible. One way of doing this is to attach a common rigid bar, perpendicular to the sensor lines, to the trailing end of the streamers, and keep the spacing of the streamers as wide as possible at the stem of the ship. A large ship is necessary both to keep the lines widely spaced, and to accommodate the equipment associated with doing this.

[0005] It is difficult to reproduce results obtained by towing such streamers, since the position of the sensors trailing behind the ship is uncertain and cannot be precisely repeated. This is especially inconvenient when it is wished to monitor some aspect of a particular region of the seabed over time.

[0006] As a result, arrays of cables are now installed onto the seabed. A number of lines of cables containing sensors are deployed from the stern of a ship as previously, and allowed to settle upon the seabed. These parallel lines of cables are connected at one end to a common perpendicular cable which includes a pick up point.

[0007] The seabed array is deployed in a similar way to the towed array, and again requires a large ship and much equipment to space the lines of sensors.

[0008] The invention also relates to an apparatus and method for deploying probes and sampling devices. Presently such probes are deployed using so called push sampling techniques which require a dedicated or pre-existing casing into which a sampling device or probe is introduced. These sampling probes are then advanced into the casing to sample and test the formation at the lower end of the casing.

Additional lengths of casing are required to reach lower depths in the formation. Drilling will usually be required before the casing can be installed. A derrick is required to deploy the casing lengths, and to deploy the sampling apparatus and its packing to the casing wall.

[0009] It is an object of the invention to provide an improved apparatus and method for the deployment of probes and sampling devices and improved sampling devices therefore.

[0010] An object of the present invention to provide a form of seabed array and method of deployment of the same which is more efficient and convenient than the prior art methods.

[0011] A further object of the present invention is to provide a means for quickly and easily securing an anchor for a mooring line upon the seabed, with less chance that the anchor point will not be properly embedded.

[0012] A further object of the present invention is to provide a means of applying further operations to the anchor upon the seabed in order to ensure that it is more reliably secured.

[0013] According to the present invention there is provided a seabed installation apparatus comprising

[0014] a soil penetration means

[0015] a deployment line from which the soil penetration means is suspended

[0016] a mooring line attached to the soil penetration means the mooring line being releasably secured to the deployment line.

[0017] Preferably the mooring line is shorter than the deployment line. Preferably the deployment line supplies power to the soil penetration means. The deployment line is preferably releasably attached to the soil penetration means.

[0018] A Seabed Installation apparatus and method of deployment embodying the invention will now be described, with reference to the drawings, of which;

[0019] **FIG. 1** shows the apparatus contained on a vessel ready for deployment,

[0020] **FIG. 2** shows a first stage of deployment of the apparatus of an embodiment of the invention being deployed from a vessel,

[0021] **FIG. 3** shows a second stage of deployment of the apparatus of an embodiment of the invention being deployed from a vessel,

[0022] **FIG. 4** shows a third stage of deployment of the apparatus of an embodiment of the invention being deployed from a vessel,

[0023] **FIG. 5** shows a cross-sectional view of the support line,

[0024] **FIGS. 6a to 6c** show further stages of the deployment of the apparatus,

[0025] **FIG. 7** shows a further stage of the deployment of the apparatus,

[0026] **FIGS. 8a** shows a side elevation and **FIG. 8b** shows a plan view of the apparatus,

[0027] FIG. 9 is a side elevation of the motor and gear box of FIG. 8a,

[0028] FIGS. 10a and 10b are a view of a further embodiment of the invention being deployed,

[0029] FIGS. 11a, 11b and 11c are views of a further anchors,

[0030] FIG. 12 is a perspective view of a further embodiment of an anchor,

[0031] FIGS. 13a, 13b and 13c are views of a further embodiment of an anchor being installed in the seabed, and

[0032] FIG. 14 is a view of a further embodiment of the anchor and associated equipment being installed in the seabed.

[0033] FIGS. 1 to 8 relate to the apparatus being used for the deployment of an anchor which would typically be used for mooring vessels and other marine structures, but it will be appreciated that the apparatus could correspondingly be applied to other seabed located devices such as sensing means for investigating the properties of the sea bed.

[0034] During sailing and while being handled at the dock the equipment occupies a secure standard container dimensions.

[0035] Referring to FIG. 1, the apparatus 15 is contained on a vessel 10 ready for deployment. The apparatus is contained in a container or skid 13 which can be configured to match existing standard sizes. A number of anchors 2 can be stowed within the skid 13.

[0036] FIG. 2 shows a first stage in the deployment of the anchor in which the skid container 13 splits and a top section 17 is rotated about a pivot 19 to pass through position a to vertical position b to provide a mast and working platform at the back of the vessel from which operators can lower the anchor deployment apparatus 2 is over the side of the vessel 10. A collapsible control cabin 21 is erected and provided with electric or hydraulic power from which the operators can control the deployment of the deployment apparatus 2. The anchor deployment apparatus 2 is supported by a support line 4 comprising braided wire or coiled tubing upon which it is lowered down into the water to the seabed, and also incorporating a power line. Heave compensation may be provided, for example, by the winch 29. The anchor deployment apparatus 2 is also attached to a or forerunner 6

[0037] FIG. 3 shows the anchor deployment apparatus 2 being lowered down through the water to the sea bed. When the top of the anchor is just below the work deck, it is held in this position so that the forerunner can be attached to its attachment point on the top of the anchor. The forerunner provides the link between the anchor and the mooring line which is attached when the rig or other item to be moored arrives on location. Preferably a buoy 8 is slidably connected to the forerunner to help in its location and pick up at a later time. Once the shackle pin is secured, the winch line deploys the anchor and the forerunner over the back of the vessel, the forerunner can be any length; in this example it is 300 ft long. As the top of the forerunner is guided by a roller fairlead over the end of the vessel, the buoy 8 is attached to ensure the top 25-50 ft of forerunner is buoyant to ensure it can be easily found by a ROV (remote operated vessel).

[0038] The entire system is then lowered using the wire rope. The wire rope may either contain electrical power cables or it may have a hydraulic line attached for powering an auger fitted to the bottom of the anchor. Since the wire rope 4 is heave compensated, the anchor moves smoothly to the seabed independently of the heave of the vessel. In FIG. 4 the anchor deployment apparatus 2 is shown having reached the seabed 25 and the anchor device 2 has started to penetrate the seabed. The forerunner 6 has been released from the vessel, some length remaining above the sea bed. The forerunner 6 preferably includes a signal transmission means for transmitting a signal to signify its location.

[0039] Referring to FIG. 5, the support line 4 comprises power cables 26 (preferably electric, though hydraulic could be used) arranged in a packed formation, surrounded by armoured braids 27 to protect the power cables and support the weight of the anchor device 2.

[0040] FIGS. 6a to 6c show the anchor deployment apparatus 2 in more detail. As the anchor 2 nears the seabed 25, it is powered up, and as it touches down it will immediately begin to drive itself into the seabed. The electric or hydraulic motor drives the auger tip via a gearbox, so very high torques will be possible at the auger, so that it has ability to penetrate a variety of materials. The benefit of the electrical system is that the current demanded by the electric motor will be directly proportional to the torque required by the auger. This will be very helpful in determining the resistance of the soil nearby the anchor so once set the anchors holding capacity will be well understood. It comprises an auger 14 arranged at the lower end which is driven by a motor 18 causing the auger to turn so driving the anchor deployment apparatus 2 into the sea bed. The motor is powered by electric power provided by the cable 4. The anchor deployment apparatus 2 also comprises flukes or fins 12 which may be extended or retracted by means of pivoting arms 16.

[0041] Referring particularly to FIG. 6a, as the auger quickly drives the anchor 2 down into the ground, the heave compensated supporting rope 4 is fed off at a steady rate as demanded by the auger. The flukes 12 are in a retracted position during the penetration phase of the anchor deployment apparatus 2 into the sea bed.

[0042] When the anchor deployment apparatus 2 has reached the desired position the flukes 12 are activated and initially extended by the arms 16, as shown in FIG. 6b. The turning direction of the motor 18 and hence the auger 14 is then reversed causing the anchor deployment apparatus 2 to retreat back upwardly. This upwards movement causes the flukes to extend further by means of the drag of the surrounding earth until the flukes are fully extended. The upward movement is then stopped and the flukes 12 in the fully extended position as shown in FIG. 6c provide the resistance to further upward movement and the desired anchoring force. The torque that the auger is subjected to as it penetrates the earth is a very good indicator of the strength of the earth and the ability of the earth at that point to provide sufficient support for the anchor. This torque is directly measurable by the current that is supplied to the motor. It is therefore possible to monitor the current and determine the best place to stop and deploy the anchor. Alternatively if a fixed length of forerunner is used to deploy the anchor in a pre-determined depth the monitoring of the current at that point will serve as a check that the earth will have sufficient strength to hold the anchor.

[0043] The auger **14** diameter is slightly larger than the outer diameter (OD) of the undeployed flukes **12** of the anchor. The discharge from the auger is fed up inside the undeployed flukes **12** and exhausted above the anchor. If a hydraulic motor is used to power the auger the fluid outlet of the water driven hydraulic motor is directed into the auger exhaust flow to assist in the movement of the waste material and reduce the skin friction

[0044] Once the set position has been reached, the wire rope **4** can be released from the anchor **2** and forerunner **6**. The release point can be at the anchor **2** if it is a disposable anchor, or it can be disconnected at the forerunner connection point above the mudline, for later reconnection. This provides the opportunity to at a later date reconnect to the anchor and power it to retract the flukes **12** and be recovered.

[0045] As shown in **FIG. 7** the electrical cable is then disconnected from the anchor deployment apparatus **2** by remote activation and the anchor has been deployed and is ready to be used. In a subsequent operation the end **7** of the forerunner **6** can be located and connected to a suitable tension cable capable of performing the desired anchoring function.

[0046] **FIGS. 8a** and **8b** show a further view of the anchor deployment apparatus **2**. The flukes **12**, as well as acting as anchors in the extended position when the anchor has been deployed, also act as torque resisting fins during penetration of the anchor deployment apparatus **2** into the sea bed. This resistance is necessary to counteract the force required to be applied to the auger in order for it to rotate and penetrate new earth as it progresses downwards. It will be noted that the auger **14** in this embodiment comprises individual helical discs **26** spaced along the auger shaft **27**.

[0047] **FIG. 9** is an view of the motor and gear box of **FIG. 8**. The motor **18** is connected to a gear box **20**, which in this embodiment provides three steps of speed reduction to the auger **14** with a corresponding increase in torque. Above the motor **18** there is a hammer vibrating device comprising a hammer anvil **22**, a hammer ramp **24** and a return spring **26**. This induces a hammering effect to the motor shaft **28** and thus to the auger **14** at the frequency of the motor shaft speed which produces controlled vibrations in the auger and the body of the anchor deployment apparatus **2** as a whole which has the effect of loosening or liquefying the earth immediately surrounding the anchor deployment apparatus **2**. which reduces the resistance to penetration. This effect is temporary as the pressure of the surrounding earth and water returns the earth to its former consistency once the auger has passed, so restoring the anchoring force of the earth.

[0048] In the embodiments so far described the soil penetration means remains in the seabed to form the anchor. The soil penetration means could equally be withdrawn after forming a hole, and a dedicated anchor inserted into this hole. Similarly although the embodiment described is for a disposable anchor, when the mooring apparatus is no longer needed in a particular spot, it may be retrieved to be reused. The auger may be driven by the motor to penetrate further so induces the flukes to close enabling the auger to drive the anchor apparatus back up.

[0049] The advantages of using the electrically driven auger of this invention will also appreciate the additional

benefits it provides. These are the real time monitoring of the azimuth and inclination, monitoring of the current demand to give a measurement of the torque required by the user, and bi-directional rotation of the auger to, for example, enable it to deploy the flukes. The apparatus can also be fitted with a battery and a transponder to provide long term feedback of the journey of the apparatus and it may also be fitted with accelerometers of seismic measurements.

[0050] Referring to **FIG. 11a**, the anchor is suspended from a generally central power and support line **6**. The fore-runner **4** is attached to the anchor by a hinged shackle **32** spaced from the central axis. A snorkel **34** may also be fitted to the anchor, to transport fluid and cuttings away from the soil penetration means. The snorkel ideally is long enough to extend to above the mud line when the anchor is at its greatest depth. The soil penetration shown here is a drill bit, in this example a roller cone drill bit, configured to include counter rotating drill bit elements so as to produce no or minimal torque as the drill engages the seabed material. An auger suitable for soil penetration **31** is shown in more detail in **FIG. 11b**. Referring to **FIG. 11c**, another possible soil penetration means is a jetting head.

[0051] **FIG. 12** shows the anchor with the flukes **12** in a deployed state, having been expanded by pivotable arms **36** attached to a slidable ring **38** located on the anchor's shaft **39**. In this embodiment, separate anti-torque fins **41** are positioned on the auger motor housing **42**.

[0052] Referring to **FIG. 10a**, in an alternative method of installing the anchor, the anchor **2** is lowered on a support cable **6** by a heave compensated winch from a vessel **10**. The support cable is attached by a quick connect **47** to a buoy close to the end of the mooring line. When the anchor **2** is near the seabed, an ROV **44** connected to the vessel **10** by an umbilical **46** is positioned near to the anchor **2**, and a power connection with a 'stab in' connector on the end of the mooring line **48**. The power connection could be an electrical supply, or it could be a hydraulic line, the mooring line including an appropriate conduit for the power to supply the anchor. Referring to **figure 10b**, the powered anchor is then caused to penetrate the seabed to a suitable depth and activated to secure itself, a snorkel line **34** venting cuttings, debris and fluid from the borehole made by the anchor as it penetrates the seabed. The ROV and support line are then disconnected. The anchor and mooring line are now ready to be used to tether a marine structure; an upper mooring line can be attached to the quick connect located on the buoy previously used to attached the anchor to the support line.

[0053] Referring to **FIGS. 13a**, **13b**, and **13c**, in another embodiment the anchor includes an auger comprising separate helical discs **51** (each disc comprising a helix subtending one 360° turn) spaced apart on a shaft **52**, this shaft **52** passing through a motor **53** and extending into a housing **55**. The housing includes anti-torque fins **41**. To advance the anchor through the seabed material, the motor **53** turns the shaft **52** of the auger, and the helical discs **51** advance the shaft **52** through the seabed material. The shaft **52** is free to slide axially relative to the motor **53**, which continues to turn it. When the shaft **52** reaches the end of its stroke, the motor ceases to turn the shaft, at the position shown in **FIG. 13b**. Another motor, or a separate gear of motor **53**, is engaged to draw the shaft back into the housing without rotating it. The auger discs **51** resist upward translational movement of the

auger, so the housing **55** is drawn down through the seabed material, as shown in **FIG. 13c**. In this way, the auger penetrates the seabed material without having to drag the housing behind it, the translation of the housing then being accomplished as a separate action with the auger discs acting as anchors.

[0054] Referring to **FIG. 14**, the anchor **2** could be mounted on a skid **62** and lowered to the seabed on that skid. The anchor may then conveniently be set on ramp **64** set at an angle to the horizontal (the seabed being considered approximately horizontal). The anchor is then activated so that its soil penetration means **66** (here shown as a roller cone drill bit having counter-rotating elements to eliminate or minimise reactive torque on the anchor) penetrates the seabed at the angle of the ramp **64**. The skid **62** can also be orientated azimuthally, that is, when considered from above (for example using an ROV, by rotating the support line, or by some orientation means on the skid itself). Ideally, the angle of the ramp may be adjusted as desired on the vessel before deployment. When the anchor is subsequently used to moor a marine structure or vessel, the mooring line extends in a straight line between the anchor and the mooring point on the marine structure. Where an anchor is installed vertically into the seabed, and the mooring line then tightened at an angle to the vertical, the mooring line is subjected to bending at the surface of the seabed, the mooring line being stressed at the bend; tension on the mooring line can also cause the mooring line to slice through the mud as the line attempts to lie in a straight line, weakening the securement of the anchor. Orienting the anchor in the described manner eliminates or diminishes any bending in the mooring line and any tendency for the mooring line to slice through the seabed material.

[0055] Many variations will be apparent to those skilled in the art, such as including other well known methods of attaching an anchor or sensing apparatus in the seabed, for instance the anchor may be a suction pile, or the anchor may be driven into the seabed using a charge. Naturally, features disclosed in respect of one embodiment may be transferable to the other embodiments.

[0056] Although the mooring apparatus is primarily intended for the securement of floating rigs, it can be used whenever anchor points upon the seabed are required. It may also be incorporated into other underwater apparatus.

1. A seabed installation apparatus comprising
 - a soil penetration means
 - a deployment line from which the soil penetration means is suspended
 - a mooring line attached to the soil penetration means
 - the mooring line being releasably secured to the deployment line.
2. An apparatus according to claim 1 wherein the mooring line is shorter than the deployment line.
3. An apparatus according to claim 1 the deployment line supplies power to the soil penetration means.
4. An apparatus according to claim 1 wherein the deployment line is releasably attached to the soil penetration means.
5. An apparatus according to claim 1 wherein the mooring line is releasably secured to the deployment line substantially along the length of the mooring line.
6. An apparatus according to claim 3 wherein the deployment line supplies electric power to the soil penetration means.
7. An apparatus according to claim 3 wherein the deployment line supplies hydraulic power to the soil penetration means.
8. An apparatus according to claim 1 wherein the soil penetration means includes an auger.
9. An apparatus according to claim 1 wherein the apparatus includes fins capable of resisting torque generated by the action of the soil penetration means.
10. An apparatus according to claim 1 wherein there is included measurement and control means capable of assessing the penetration characteristics of the soil penetration means and altering the action of the soil penetration means in response to the penetration characteristics.
11. An apparatus according to claim 10 wherein the current supplied to the soil penetration means is measured.
12. An apparatus according to claim 1 wherein the soil penetration means includes securement elements having a changeable profile, when considered in the direction of the mooring line.

* * * * *