



US 20060096853A1

(19) **United States**

(12) **Patent Application Publication**
King

(10) **Pub. No.: US 2006/0096853 A1**

(43) **Pub. Date: May 11, 2006**

(54) **ELECTROCOAGULATION SYSTEM**

Publication Classification

(76) **Inventor: Cameron James King, Albion (AU)**

(51) **Int. Cl. C25B 9/04 (2006.01)**

(52) **U.S. Cl. 204/230.2**

Correspondence Address:

TAROLLI, SUNDHEIM, COVELL & TUMMINO L.L.P.

1300 EAST NINTH STREET, SUITE 1700 CLEVELAND, OH 44114 (US)

(57) **ABSTRACT**

A control assembly for an electrocoagulation cell (1) comprising a plurality of electrodes, a releasable connection means (6) between at least a selection of the electrodes and electrical connection means (9, 10, 9A, 10A) attached to the releasable connection means (6) which in use is connectable to a power supply (12). An electrocoagulation system comprising a plurality of electrodes (2), an electrolytic cell (1) having an internal chamber which contains the plurality of electrodes (2), and a power supply (12) connectable to a power source and also connectable to the electrodes said power supply having control means (14, 24) for providing a selected constant output current or selected constant output voltage whereby the electrolytic cell may process samples of varying characteristics.

(21) **Appl. No.: 10/535,540**

(22) **PCT Filed: Nov. 19, 2003**

(86) **PCT No.: PCT/AU03/01549**

(30) **Foreign Application Priority Data**

Nov. 19, 2002 (AU)..... 2002952743

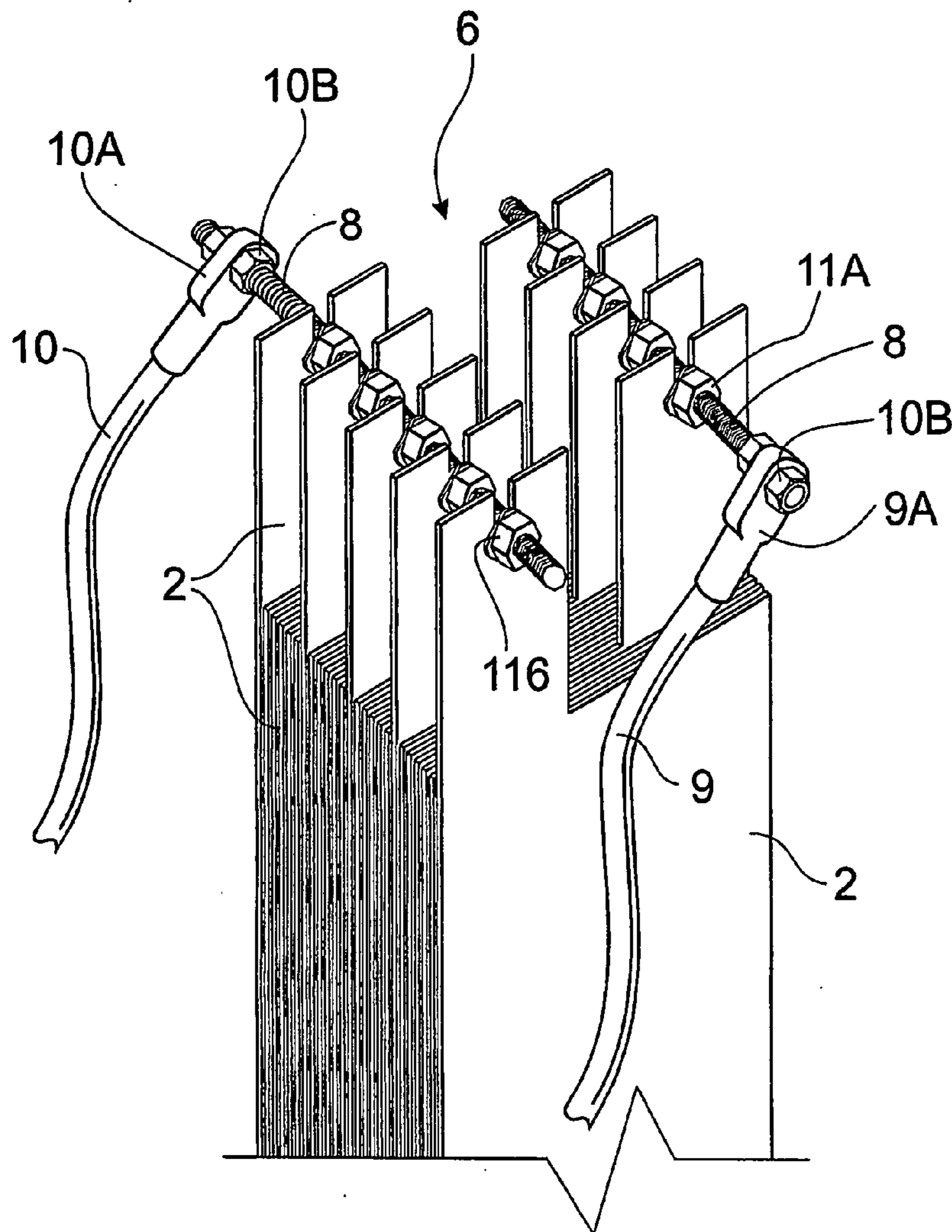

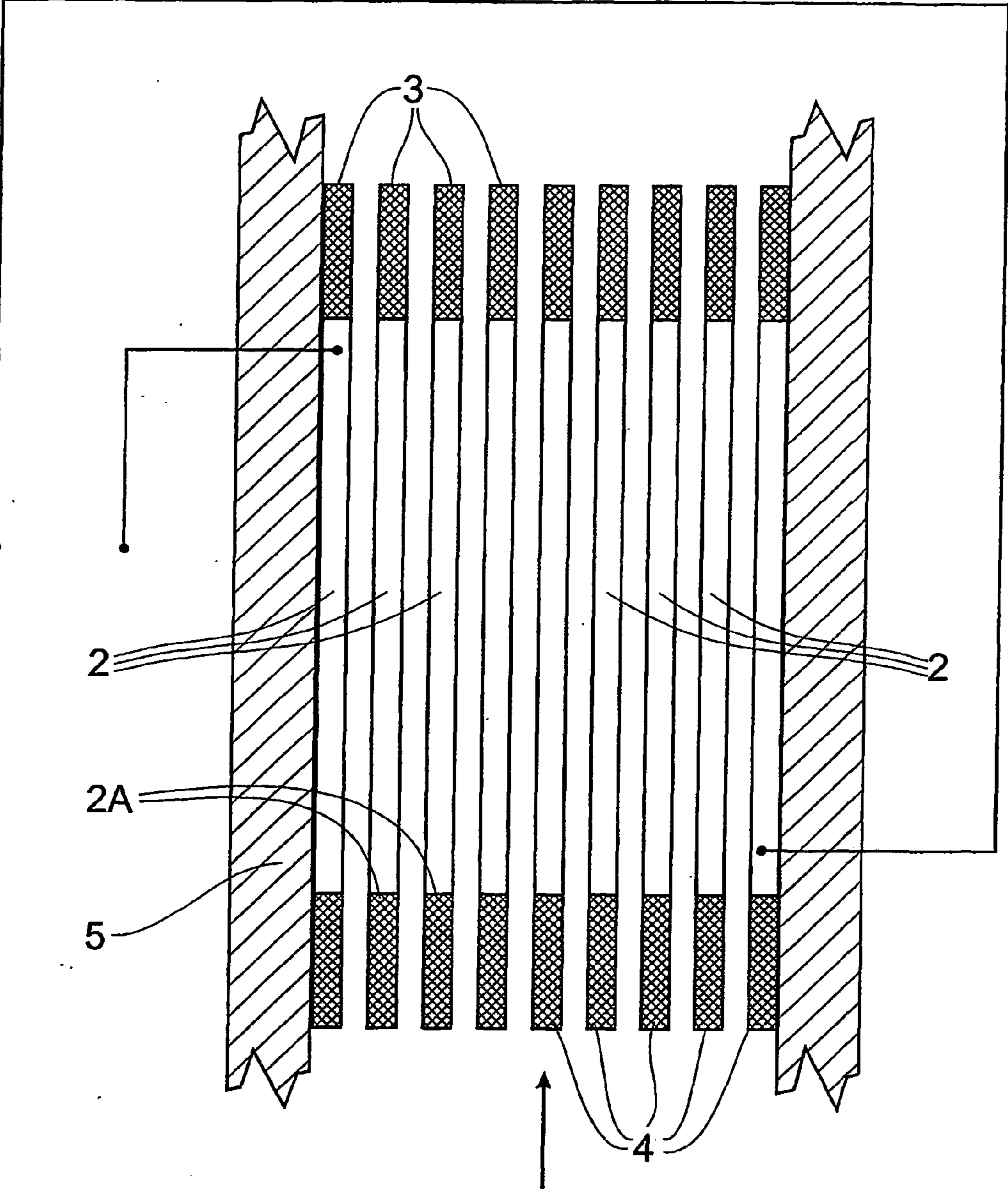

FIG. 1

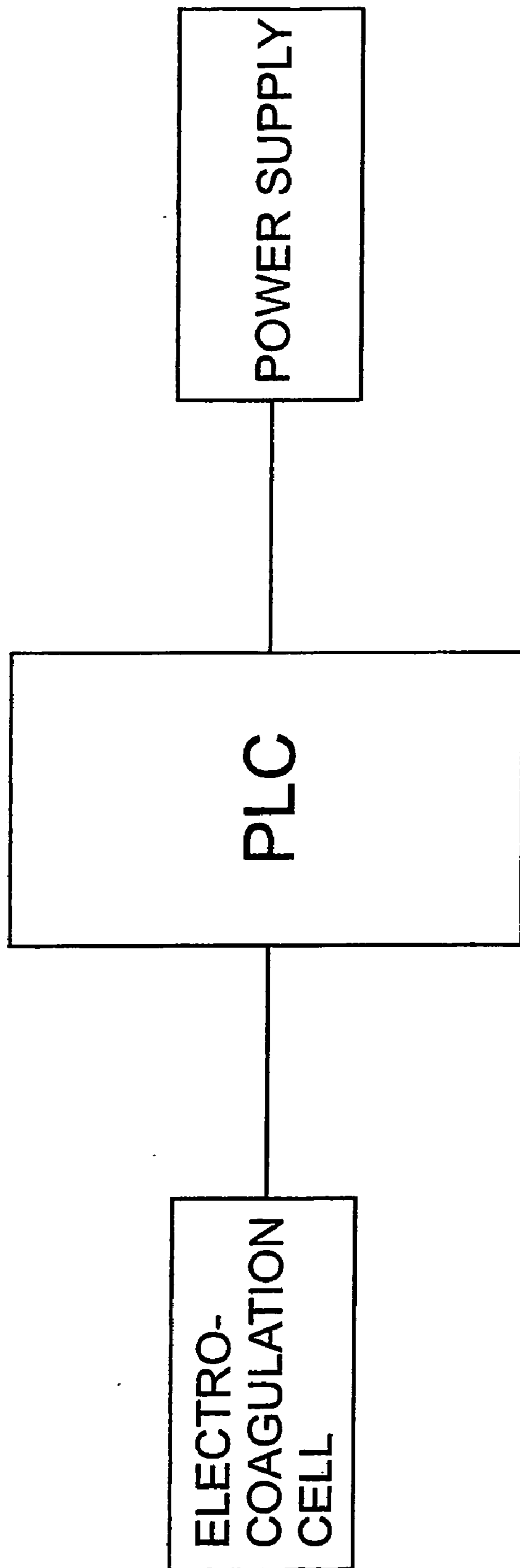

FIG. 2

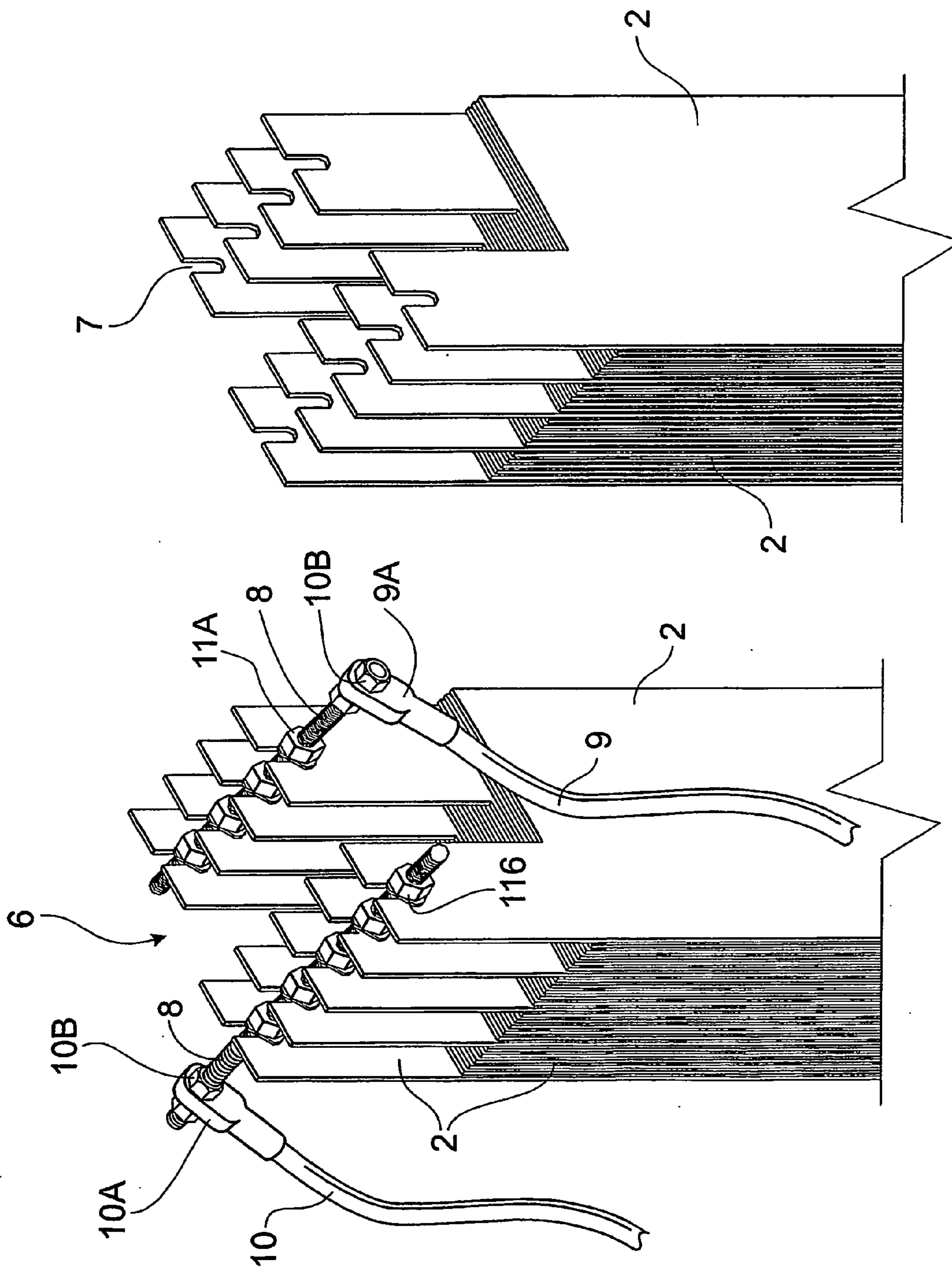

FIG. 3a

FIG. 3b

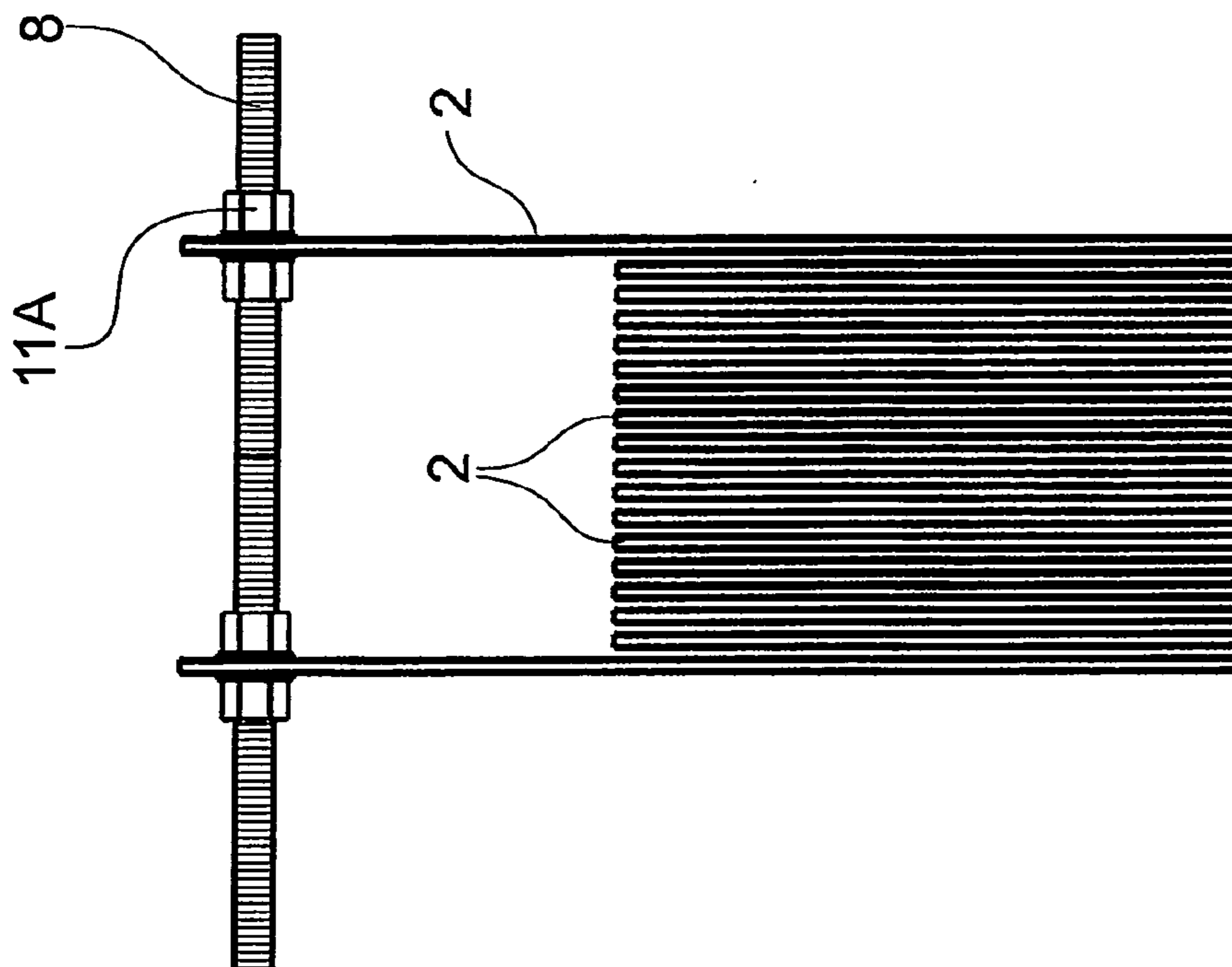

FIG. 3d

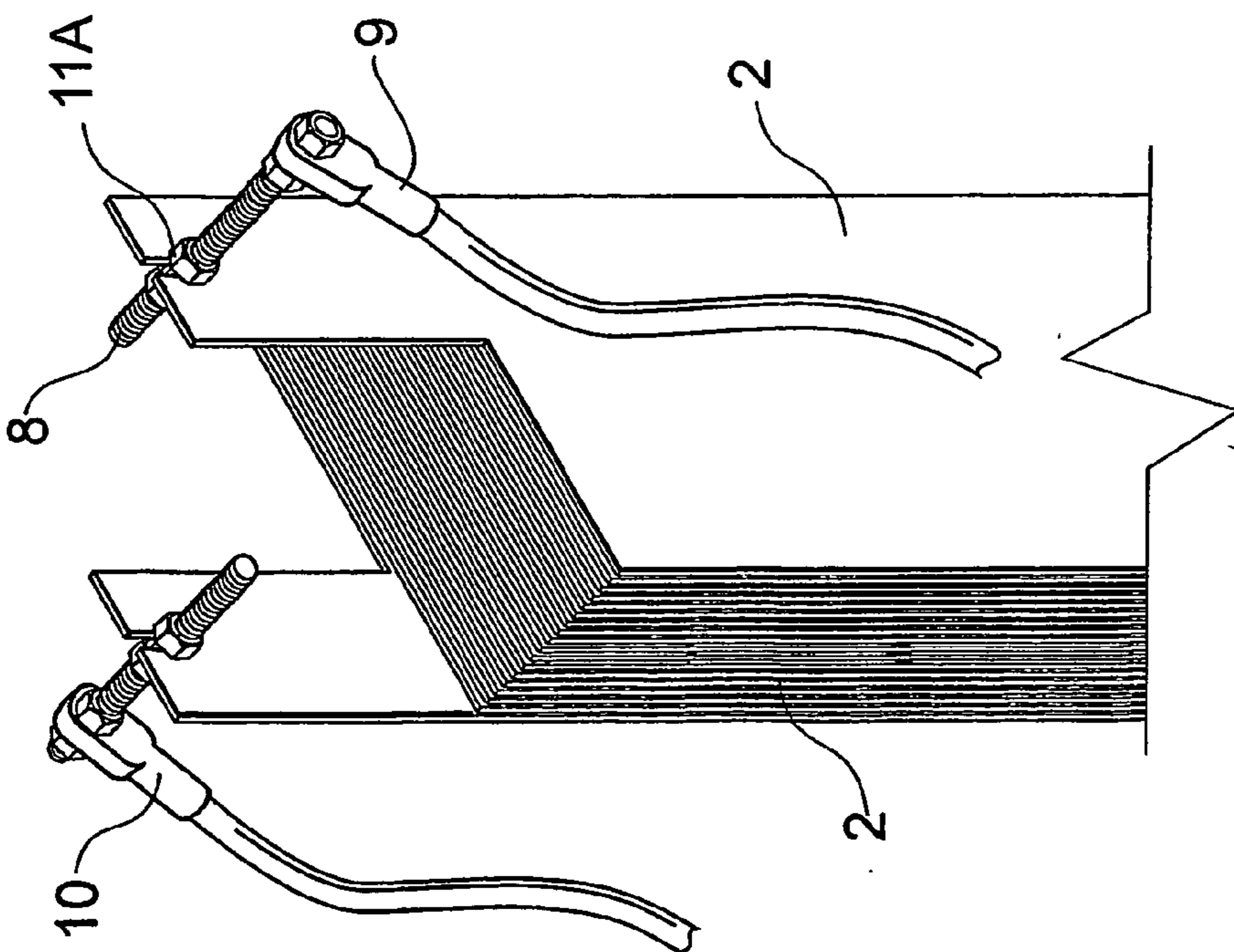

FIG. 3c

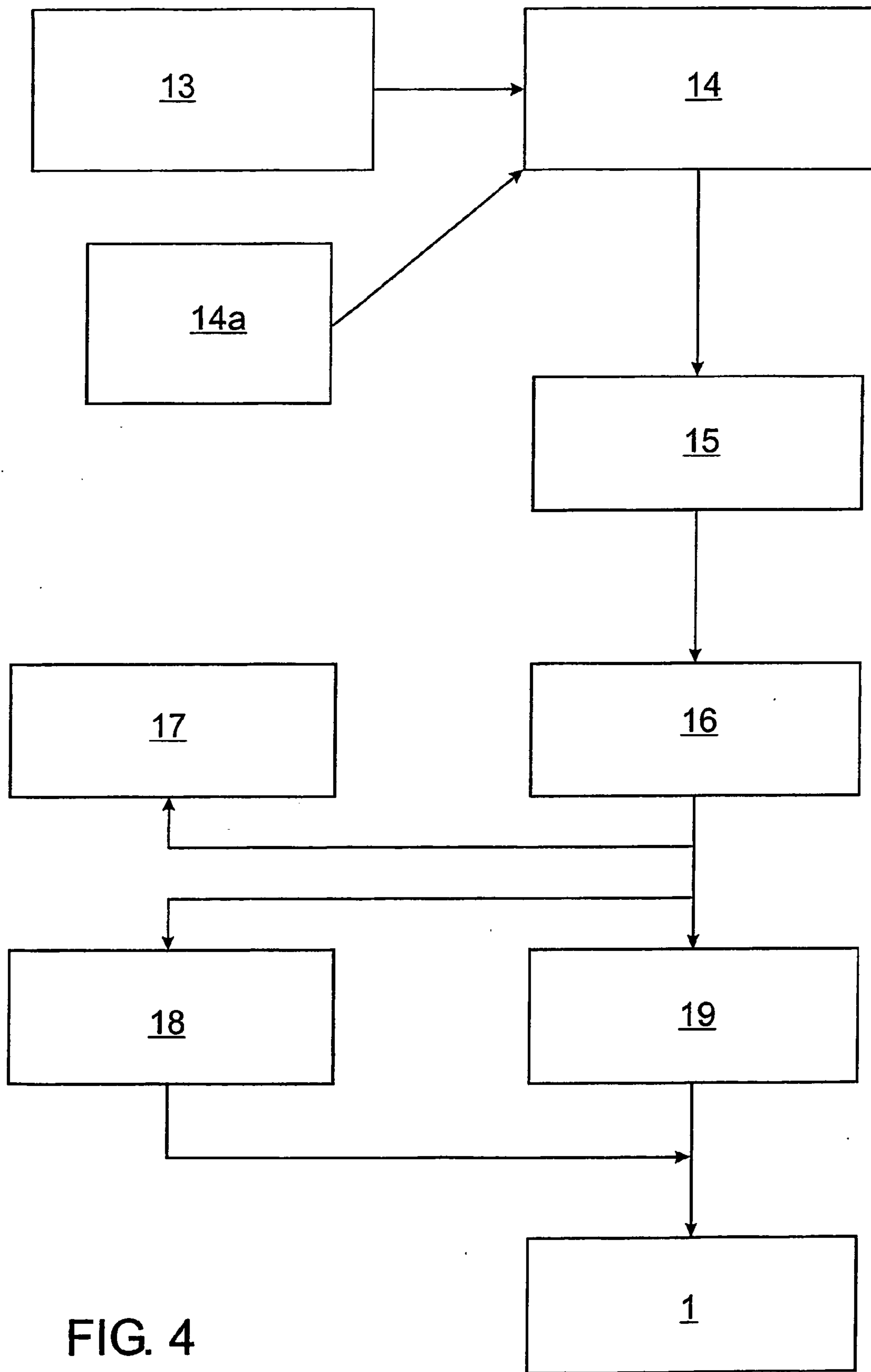

FIG. 4

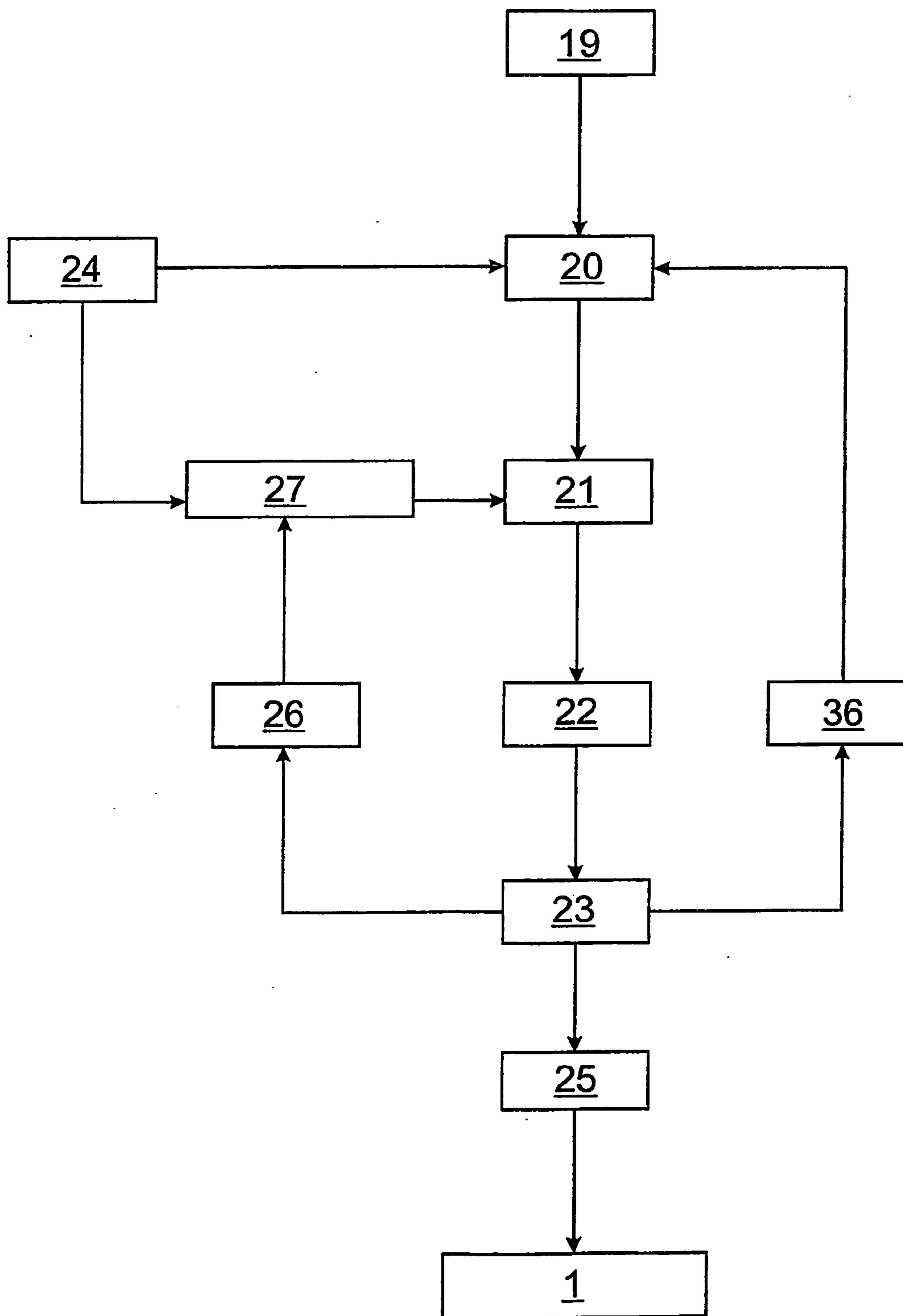

FIG. 5

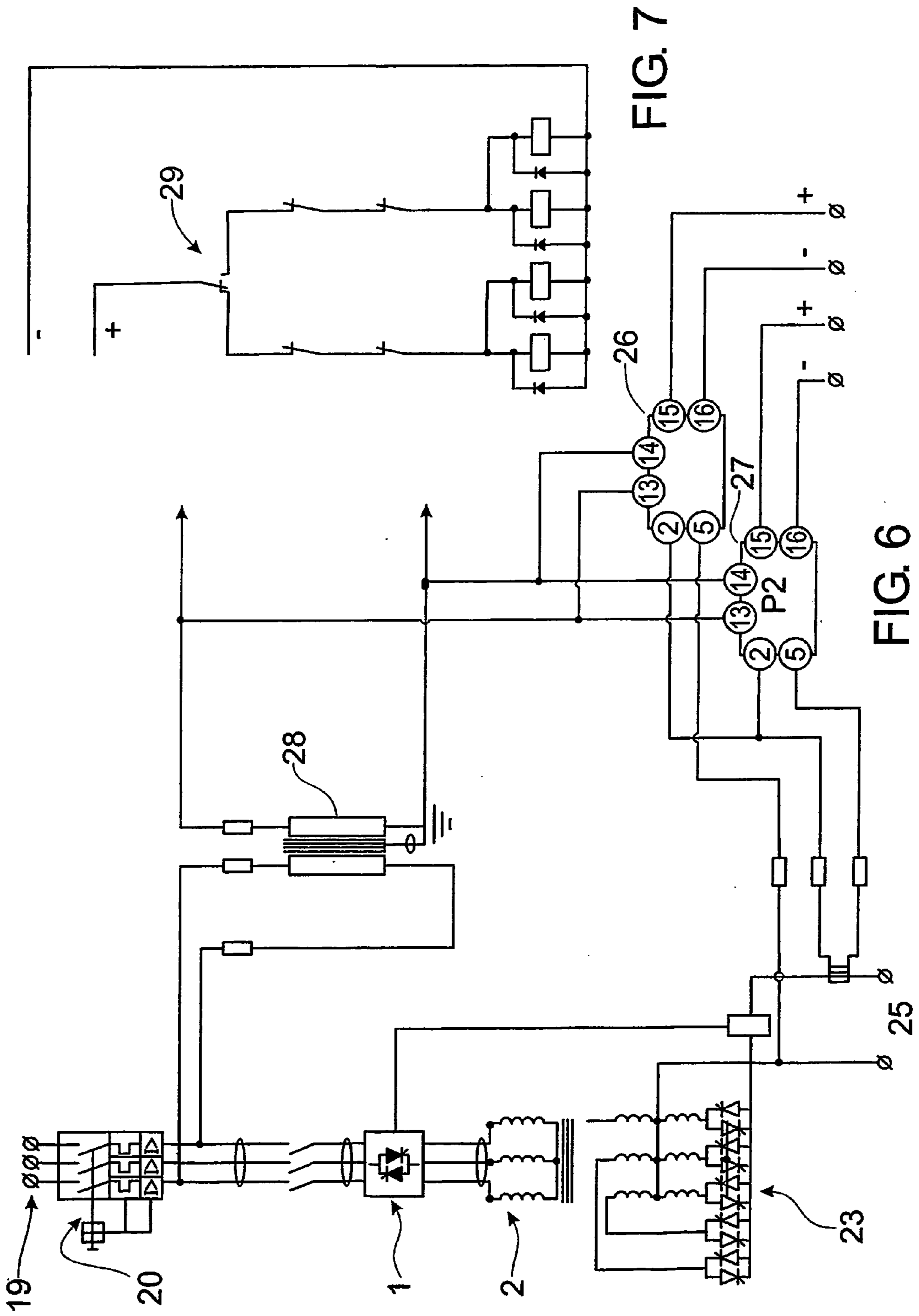

FIG. 7

FIG. 6

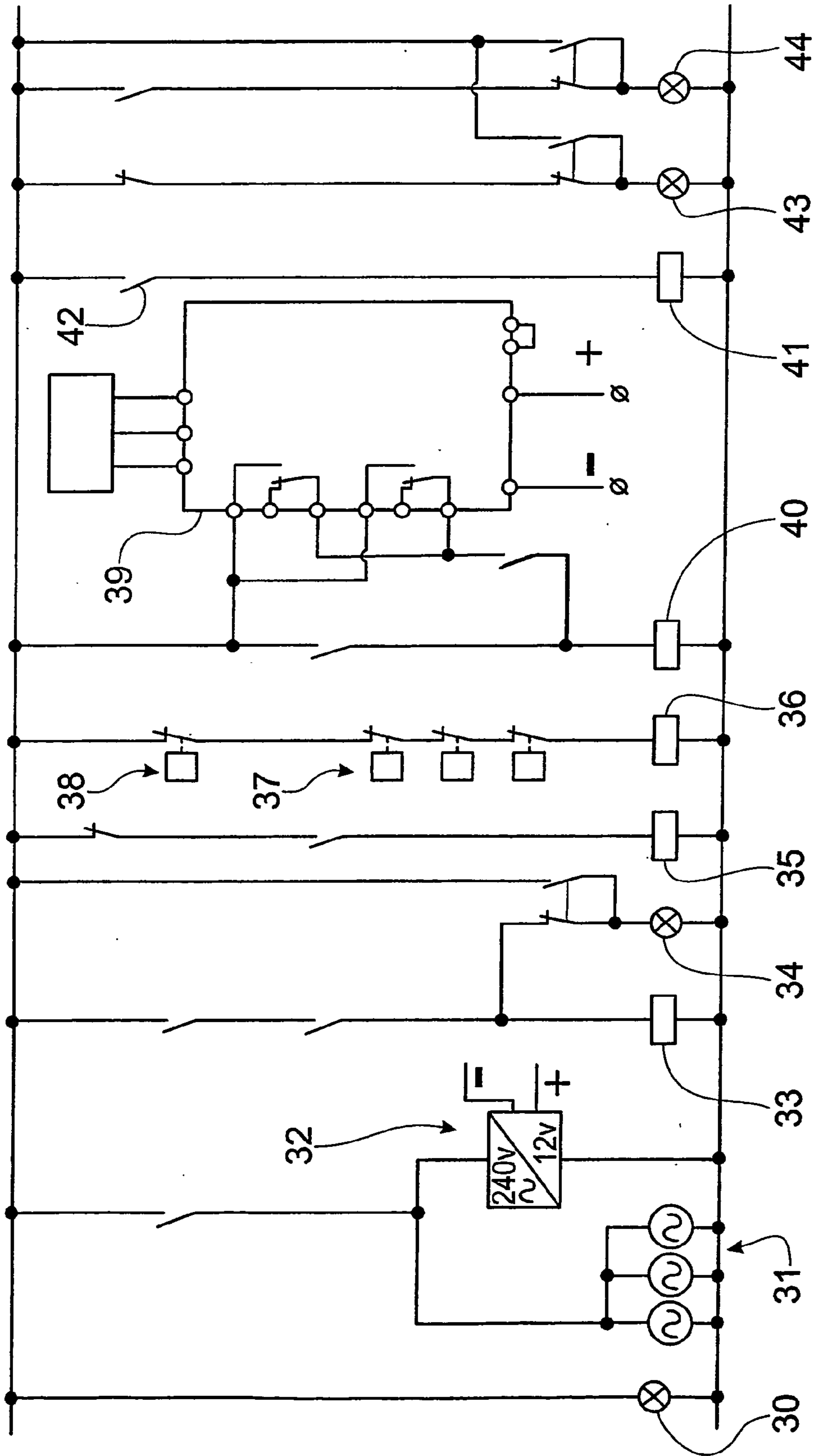

FIG. 8

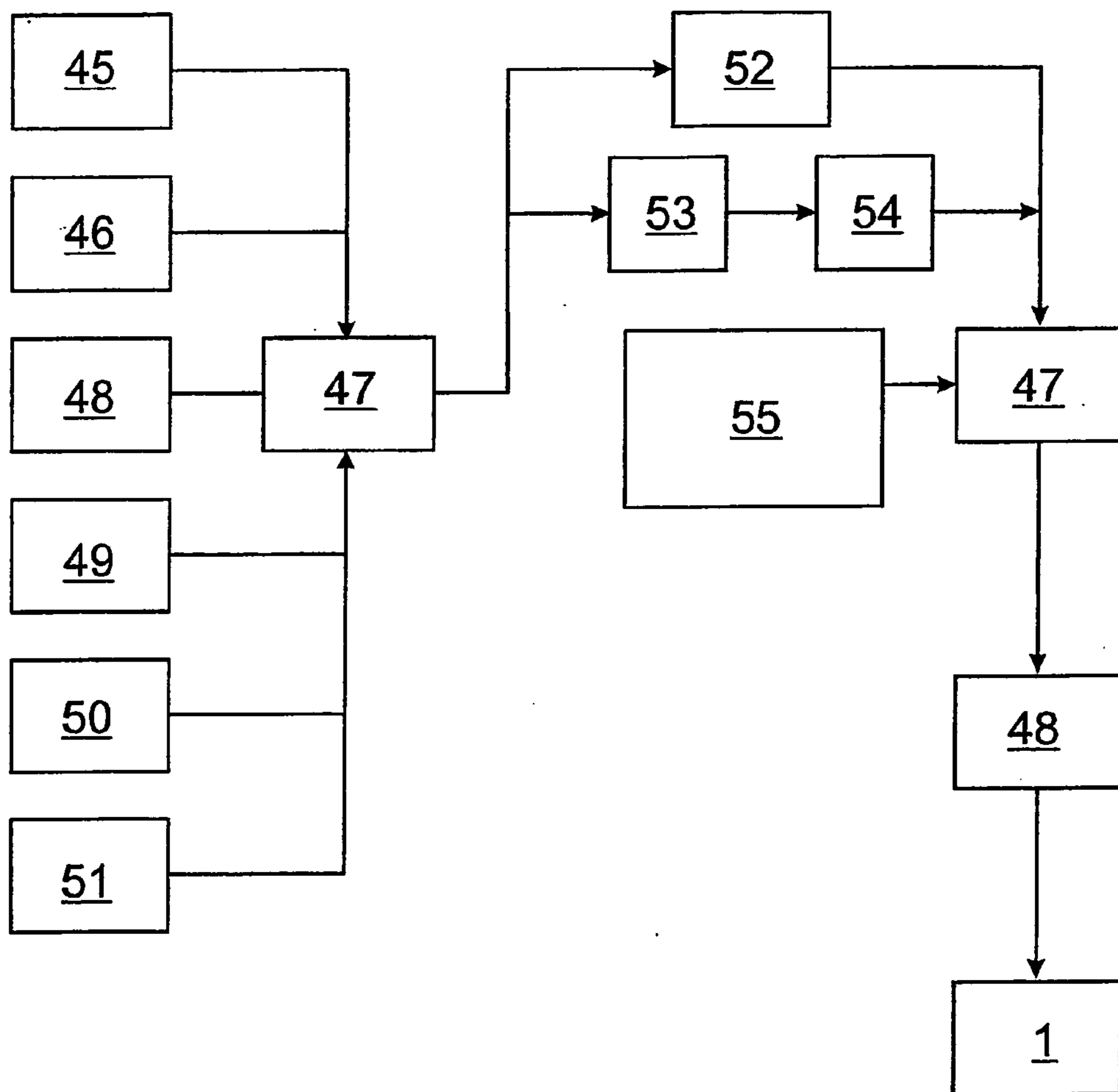

FIG. 9

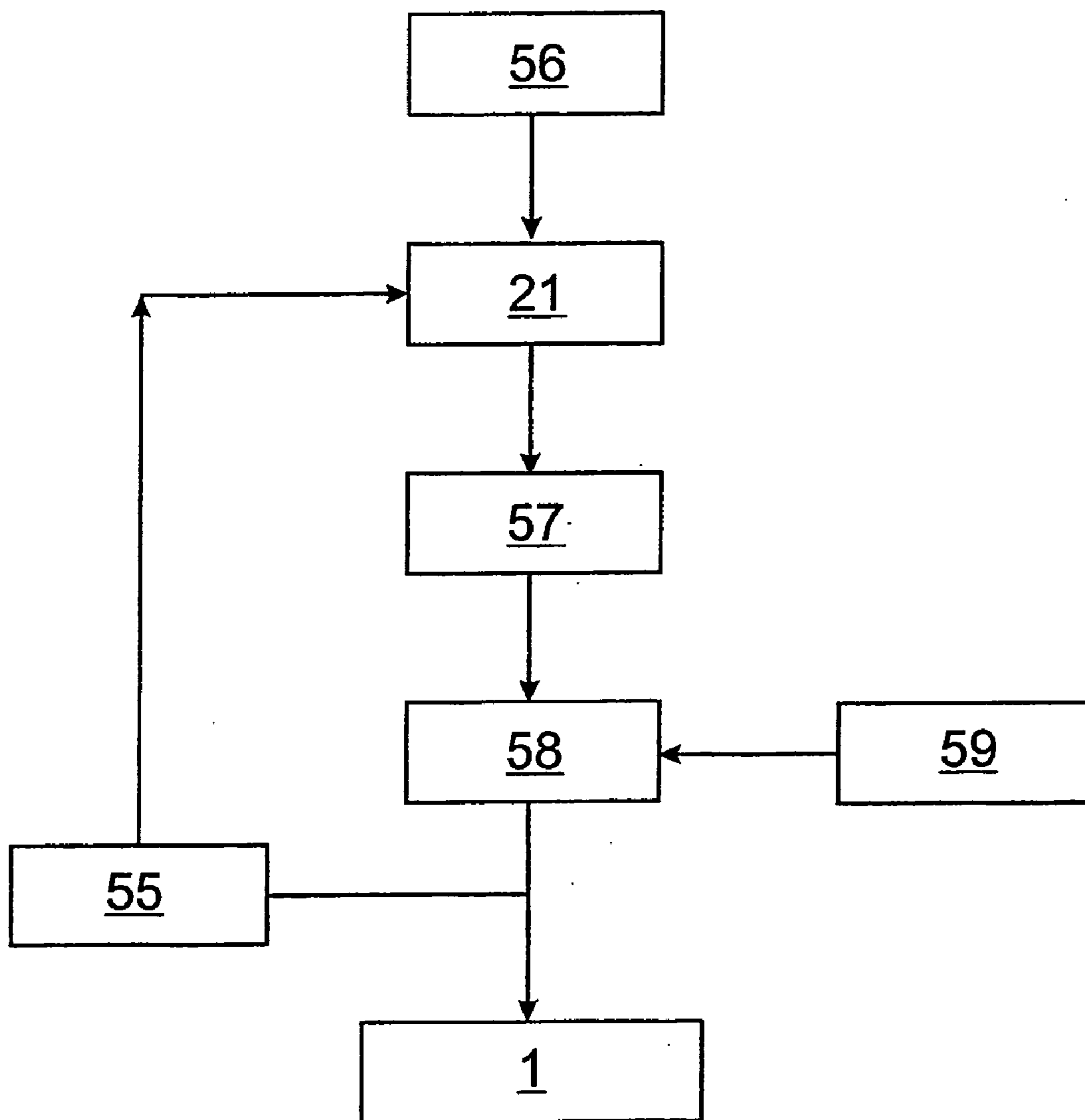

FIG. 10

ELECTROCOAGULATION SYSTEM

TECHNICAL FIELD OF THE INVENTION

[0001] This invention relates to an electrocoagulation system which an electrocoagulation cell includes as well as a control assembly for an electrocoagulation cell.

BACKGROUND OF THE INVENTION

[0002] Electrolytic cells are commonly used for treating liquids to change the liquid for a predetermined purpose. Electrocoagulation is a particular electrolytic treatment process for separating and removing contaminants or undesirable contents from a liquid.

[0003] Typically an electrocoagulation cell contains electrodes and an electrolyte that is to be treated. The treatment process may be performed in a number of ways depending on the nature of the electrolyte.

[0004] Numerous prior patents describe electrocoagulation systems of which AU 707432 describes an electrochemical treatment device for softening water. The device is powered by a current generator producing a current which is adjustable and applied to an anode and cathode terminal of an electrolytic tank. The cathode is comprised of a number of plates which are held in place by connection of a plurality of bars. The bars are joined together to an anode terminal. The plates are joined together by a separate bar to a cathode terminal.

[0005] Another prior system is described in AU 738707 where a portable electrocoagulation apparatus includes an electrolytic cell having a plurality of vertically extending reaction blades. A selection of the blades have tabs which are electrically connected to power terminals for receiving power. The blades are held in place by a plurality of non-conductive rods. A control unit controls the system operation and applied power.

[0006] A further system is described in U.S. Pat. No. 4,790,923, where an electrolytic cell produces a halogen biocide and oxygen in a liquid containing a halogen salt. A plurality of bipolar electrode plates is mounted in the cell with only a select number of electrodes being connectable to a power supply.

[0007] Yet another system is described in WO 94/00860 where an electrolytic filter has electrically configurable connections to active electrodes in an electrolytic cell. A sensor senses a resistivity variation in the electrolytic solution and a control circuit varies the current flow by adjusting the separation between electrodes using relay contact switches for electrically connecting or disconnecting each active electrode.

[0008] A major drawback of the above systems is they are designed for a specific electrolyte or liquid which is to be treated. The electrodes used, their quantity and desired power requirements are specific to the liquid being treated.

[0009] A further drawback of conventional electrocoagulation systems is the high cost associated with designing a system for each specific application. Substantial testing and modification is required where the liquid stream changes in its concentration of contaminants.

OBJECT OF THE INVENTION

[0010] It is an object of the invention to provide an improved electrocoagulation system.

[0011] It is a further object of the invention to provide an improved control assembly for an electrocoagulation cell that facilitates treatment of various liquids or species.

SUMMARY OF THE INVENTION

[0012] In one form, although it need not be the only or indeed the broadest form, the invention in a first aspect resides in a control assembly for an electrocoagulation cell comprising:

[0013] (i) a plurality of electrodes;

[0014] (ii) releasable connection means between at least a selection of the electrodes comprising an elongate busbar which is arranged normal to respective top edges of each electrode in plan view and which extends through a notch, slot or aperture located in individual tabs which each extend upwardly from an adjacent top edge of each electrode whereby the busbar is spaced from the top edges of each electrode so as to avoid contact with liquid contained in the electrocoagulation cell in use as well as a plurality of fasteners attached to said busbar whereby each fastener abuts or is located closely adjacent to an adjoining surface of each electrode; and

[0015] (iii) electrical connection means attached to the busbar at each end thereof which in use is connectable to a power supply.

[0016] The releasable connection means may facilitate the number of electrodes releasably connected to be varied according to specific requirements for treating a particular electrolyte.

[0017] The electrodes may be connected in a series arrangement.

[0018] The electrocoagulation cell can treat the electrolyte at a rate of 1 Litre per minute or 5 Litres per minute or 10 Litres per minute or 100 Litres per minute or 500 Litres per minute (LPM).

[0019] In a second aspect of the invention there is provided an electrocoagulation system comprising:

[0020] (i) a controller that is selectable for providing both a constant output current and/or a constant output voltage whereby the electrolytic cell may process samples of varying characteristics;

[0021] (ii) a voltage regulator;

[0022] (iii) a transformer having a primary coil connected to the voltage regulator;

[0023] (iv) a rectifier connected to a secondary coil of the transformer; and

[0024] (v) a voltage or current regulator which receives an output from the rectifier and together with said controller effects a firing control of the voltage regulator.

[0025] The electrocoagulation system of the second aspect may also include a programmable logic control (PLC) for checking parameters associated with the flow of an electrolyte to and through the cell.

[0026] There also may be provided flow control means for delivering the electrolyte to the electrocoagulation cell.

[0027] In a preferred form of the invention, the flow control means includes a digital controller, variable AC motor drive, feed pump with pump motor and a flow transmitter.

[0028] The power supply of the second aspect may be connected to a three phase AC power source.

[0029] Preferably, the constant output current and the constant output voltage is a direct current (DC).

[0030] Preferably, if a constant output current is selected, then the DC current is maintained constant with respect to a reference set by the control means and the DC voltage may vary.

[0031] Preferably, if a constant output voltage is selected, then the DC voltage is maintained constant with respect to a reference set by the control means and the DC current may vary.

[0032] The constant output current or voltage may be set at a level according to the type of electrolyte which is to be treated.

BRIEF DESCRIPTION OF THE DRAWINGS

[0033] **FIG. 1** is an illustrative embodiment of an electrocoagulation cell to which a power supply of the present invention is applied;

[0034] **FIG. 2** is a process flow diagram of the electrocoagulation system in accordance with the present invention;

[0035] **FIGS. 3a-3d** are schematic illustrations showing a varied number of electrodes and electrode configurations that can be connected to a power supply, in accordance with the invention;

[0036] **FIG. 4** is a block diagram of a power supply in accordance with one embodiment of the present invention;

[0037] **FIG. 5** is a schematic diagram of a power supply in accordance with a second embodiment of the invention;

[0038] **FIG. 6** is a basic circuit diagram of the power supply shown in **FIG. 4**;

[0039] **FIG. 7** is a basic circuit diagram of a reversing relay control circuit associated with the power supply of **FIG. 4**;

[0040] **FIG. 8** is a basic circuit diagram of control circuits associated with the power supply of **FIG. 4**;

[0041] **FIG. 9** is a schematic diagram of a system start control of an electrocoagulation system using a power supply of the present invention; and

[0042] **FIG. 10** is a treatment rate control schematic of an electrocoagulation system using a power supply of the present invention.

DETAILED DESCRIPTION OF THE PREFERRED EMBODIMENT

[0043] In a preferred form, the invention will be described with reference to an electrocoagulation cell and system of the type described in the co-pending International Patent Application No. PCT/AU01/00054. However, it should be noted that the invention could also be realised with other types of electrocoagulation cells.

[0044] Referring now to **FIG. 1**, there is generally shown an electrocoagulation cell **1** comprising a plurality of electrodes **2**, in the form of plates, which form the electrocoagulation cell. Plate extensions **3** and **4** abut the respective edges **2A** of the electrodes **2** which form part of a housing **5** of the electrocoagulation cell **1**. The extensions **3** and **4** prevent short-circuiting between the electrodes **2** of different potential. DC power to the electrocoagulation cell is applied to the two end electrodes as shown in **FIG. 1**.

[0045] The electrocoagulation cell is used in fluid treatment plants for treatment and purification of a conductive solution such as might be produced by a manufacturing, treatment, refining or other process. Typically, a conductive solution is caused to flow between electrodes **2** at different electrical potentials. A current is caused to flow between the electrodes through the solution which results in a chemical reaction within the solution and in many cases, between the solution and the electrode material which comprises the electrode.

[0046] The electrodes **2** of the electrocoagulation cell **1** are made from metal alloys or other suitable metals and are shaped to fit into individual grooves (not shown) within the electrode housing **5**. The electrodes are designed to provide sufficient reaction surface area to effectively treat an electrolyte solution such as water up to the maximum design rate of cell **1**. Electrodes are unipolar (anodic or cathodic) or bipolar (anodic and cathodic). Bipolar electrodes have both surfaces of the electrode plate reacting with the electrolyte solution. One side is anodic, the other cathodic. Unipolar electrodes are either wholly anodic or wholly cathodic. Unipolar electrodes located at the ends of the reaction cell, (see **FIG. 3c**), have only one surface of the electrode reacting with the electrolyte solution. Unipolar electrodes located between bipolar electrodes, (see **FIG. 3a**), have both surfaces of the electrode reacting with the electrolyte solution.

[0047] Referring to **FIG. 2**, in operation, once the material to be treated is determined and the nature of the electrocoagulation cell **1** is determined, that is, the type, number and the configuration of the electrodes, the operating parameters of the electrocoagulation system is checked by a Programmable Logic Controller (PLC). The required flow rate of electrolyte or liquid, such as 5 or 100 Litres per minute or any flow rate there between is determined. All switches and valves are checked so that they are opened or closed as required and there is no fault conditions detected in the system.

[0048] When the operating parameters of the electrocoagulation system are satisfied, a power supply is adjusted in its voltage or current and applied to the system, according to the specific power requirements for a particular liquid or species to be treated in the electrocoagulation cell. The power is disengaged whenever any of the operating parameters are outside their operational range or when a user manually stops the electrocoagulation system by activating a stop switch.

[0049] Referring now to **FIGS. 3a-3d**, there are shown electrode configurations for two different species or liquids to be treated. **FIG. 3a** shows a releasable connection means **6** in the form of a busbar connection, for releasably connecting a selection of a plurality of electrodes **2** in the electrocoagulation cell. In this arrangement, there are

twenty-five electrodes with nine electrodes connected by the busbars, for treating one particular species or liquid. Two busbars are used, one for each polarity.

[0050] Each selected electrode **2** includes a slot **7** (shown in **FIG. 3b**) for receiving a bar **8** to which is applied a power source via lead connections **9** and **10**. Bar **8** is placed in slots **7** of each of the electrodes **2** in a series alignment and the bar is secured to the electrodes by securing means comprising a nut **11a** and washer **11b**.

[0051] The connected electrodes are uni-polar and hence are either anionic or cationic depending on the polarity of the power applied through power leads **9** and **10** each of which have connectors **9A** and **10A** having apertures (not shown) retained by nuts **10B** on each side of connectors **9A** and **10A**. The remaining sixteen unconnected electrodes are bi-polar and they are charged by the energised electrolytic solution.

[0052] Referring to **FIG. 3c**, there is shown an electrode arrangement for treating a second species or liquid. In this configuration there are a total of eighteen electrodes of which two are connected by the busbars. Only two electrodes therefore are unipolar, being the end electrodes to which power is applied and the remaining are bipolar as shown in **FIG. 3d**.

[0053] In the above arrangement of the busbar, the bar is threaded so that the securing nuts **11a** can be threadably secured to the bar thereby bearing tight against the electrodes **2** to secure them to the bar **8**. The bar may be made of a brass material which is resistant to rust and has good conductivity properties. However, other suitable material having these properties may be used to secure and electrically connect the electrodes, such as steel.

[0054] The washer **11b** assists in the protection of the electrode against wear from the nut **11a**. The washer also increases the surface area of the current applied to the electrodes.

[0055] In operation, the bar **8** is placed in the slots **7** of adjacent electrodes **2** and the securing nuts **11a** and washer **11b** are secured against the electrodes to hold it in place. To replace an electrode, the securing nuts **11a** are loosened so that they no longer bear tight against the electrode and the bar is simply lifted so that access can be gained to the electrodes as shown in **FIGS. 3a** and **3b**.

[0056] The electrocoagulation cell is designed to treat fluid such as water at various flow rates. In one embodiment of the invention, a power supply outputs the desired power requirements for treating the electrolyte solution at various flow rates.

[0057] Referring now to **FIG. 4**, there is shown a power supply **12** for the electrocoagulation cell **1** of **FIG. 1**. The power supply **12** can be used for treating an electrolyte solution at a maximum flow rate of five Litres per minute, 5 LPM. The power supply **12** receives a single phase AC input **13** of 240 v at 10 amps (maximum). A variac **14** is adjusted by operation of control dial **14a** to increase or decrease the voltage and current. The adjusted voltage and current are applied to a transformer **15** for stepping up or stepping down the voltage as may be required. For example, if the system is configured for a flow rate of five Litres per minute, 5 LPM, a maximum output of 110 v DC at 10 amps

is required. However at 100 LPM, a maximum output of 110 v DC at 300 amps is required.

[0058] A rectifier **16** converts the AC voltage into a DC signal and the adjusted and rectified signal is displayed on a display **17** for viewing by an operator. Depending on the type of treatment required and the types of electrodes used, the output signal may be a DC signal with a negative polarity adjusted by a reverse polarity timer **18** or a positive output signal adjusted by a forward polarity timer **19**. The output of the power supply **12** is then applied to the busbar and electrodes of the electrocoagulation cell **1**.

[0059] The variac of the power supply is rated at 15 amps with a maximum of 250 v AC. If the power source is required for a 10 LM electrocoagulation system, the variac is required to be rated at 28 amps due to the increased flow rate.

[0060] If the electrocoagulation system is operating at 10 LM, then a maximum output of 110 v DC at 28 amps is required to power the system. The power supply for the 10 LM system is similar to the 5 LM system except that it requires a larger variac rated at 28 amps and powered by 240 v single phase AC input at 20 amps (maximum).

[0061] The power supply will now be described in more detail with reference to **FIGS. 5** to **8**. Referring to **FIG. 5** there is shown a power supply for supplying DC power for the electrocoagulation cell **1** for operating at 100 LPM. It will be appreciated however, that the power supply can also be used with 1, 5, and 10 LPM systems using single phase AC input.

[0062] The power supply in **FIG. 5** is fed with a three phase, AC input of 415 v through lock **19**. However, it will be understood that any suitable source of electrical power may be used. The input power is connected to an adjustable main switch **20**, which may be, for example a Terasaki™ circuit breaker XS125CJ633P or a similar circuit breaker. The main switch **20** is connected to a voltage regulator **21**, which is preferably a three-phase SCR digital power controller such as that marketed by Fastron Technologies Pty Ltd. A phase controlled variable output from the voltage regulator **21** is supplied to a primary coil of a main transformer **22**, the secondary of which is connected to a rectifier **23**, such as a matched hexaphase back to back SCR module.

[0063] A voltage and a current potentiometer **24** (shown as one) connect between the main switch **20** and the voltage regulator **21** to control a DC output **25** to be either constant current or constant voltage. A voltage or current regulator **26** receives an output from the rectifier **23** and together with the potentiometer **24**, effect the firing control **27** of the voltage regulator **21**.

[0064] In the present embodiment, the power supply has two distinct modes of operation that allow the user to maintain either constant output voltage or constant amperage. These values are set by the voltage or current potentiometer **24**. When the current potentiometer is set for constant current, the voltage pot is rotated to "100%" which allows the powersupply to float output voltage between 0 and a full rated DC voltage. The constant current pot can then be set to the desired output current depending on the type and consistency of the electrolyte being treated.

[0065] As the load is increased or decreased, the amperage will remain at the set point while the voltage will vary. If the

constant voltage pot is set at less than 100% output, the voltage will then be limited to this set point. In this case, if the set point is less than the required voltage to maintain a set current level, an automatic cross over to constant voltage will occur.

[0066] Alternatively, to maintain constant voltage, the constant current pot can be rotated clockwise so that it is at 100% thereby allowing the power supply to float the output current between zero and full rated DC amperage.

[0067] As noted above, the constant voltage pot is set to the desired output voltage, such as 110 v DC and as the load is increased or decreased, the voltage will remain at 110 v DC while the DC amperage will vary. If however, the constant current pot is set at less than 100%, the output current will be limited to the set point. Alternatively, if the set current is less than the minimum current required to maintain the set voltage level, an automatic cross over to constant current will occur.

[0068] A current trip is provided for protection against exceeding a maximum DC amperage rating of the power supply. If the DC amperage is exceeded, the power supply will continue to run, however, there will not be any output. Similarly, an over temperature relay 36 is provided to sense any overheating in rectifier 23 and if there is overheating, shutting down the power supply at the main switch 20.

[0069] The power supply of the present embodiment provides control of either the voltage or the current to produce a constant current or voltage at the desired output level.

[0070] Details of the power supply are illustrated in FIGS. 6, 7 and 8. FIG. 6 shows a schematic circuit diagram of the power supply of FIG. 5. The diagram further shows display means 26 and 27 for displaying the amperage and voltage as they are adjusted. A secondary transformer 28 is connected at the primary side, to the output of the adjustable main switch 20 and supplies power at its secondary side, for monitoring and control circuits shown in FIGS. 7 and 8.

[0071] FIG. 7 illustrates a relay circuitry 29 for actuation which reverses the polarity of the rectified DC signal output 25. The circuitry will be readily known to a person skilled in the art and will not be described in further detail. It should be noted that this circuitry may also be used with the power supply for the electrocoagulation system at 1 LPM, 5 LPM or 10 LPM.

[0072] Referring now to FIG. 8, there is shown a circuit diagram of the control circuit associated with the power supply in accordance with the invention. The control and monitoring circuits include a power on indicator 30, cooling fans 31, a 12 v DC power supply 32, a mains contactor 33, a rectifier running indicator 34, a fault relay 35, an over temperature relay 36 with heat syncs 37 and transformer temperature sensor 38. A controller 39 controls the functions of the regulator 21. Any fault condition arising will give rise to actuation of the voltage regulator fault relay 40. A test lamp relay 41 has a test switch 42, and indicator lamps 43 and 44 provide visual indication for any over temperature and faults in the voltage regulator.

[0073] The operation of the process flow and the power supply will be described with reference to FIGS. 9 and 10. The power supply of the present invention is connected to an electrocoagulation cell 1 within which liquid is to be treated

by electrolysis. In operation of the system, an algorithm in a program logic control (PLC) 47 is executed to ensure a number of conditions are met. First, before DC power is supplied to the electrodes, a mode switch 45 is set to "run" and a start button 46 is actuated. PLC 47 receives status and condition signals from a DC power supply 48, a feed tank low level switch 47, a feed tank mid level switch 50 and a fault indicator 51. The PLC determines whether all the parameters are satisfied and that all the switches are closed and there are no faults conditions detected in the system. Once the initial conditions are satisfied, the PLC 47 sends a signal to actuate a feed valve 52 to open and after a time delay 53, a feed pump 54 is started to commence operation of one or more pumps to thereby circulate liquid through the electrocoagulation system.

[0074] A flow transmitter 55 provides a signal to the PLC 47 whether the measured flow rate is greater than a low flow-set point and if so, the PLC signals the DC power supply 48 to start operation to provide a voltage across the electrodes of the electrocoagulation cell 1.

[0075] The power supply will cease applying a voltage across the electrodes if the mode switch 45 is set to a function other than a "run", or a stop button is pressed, or a fault condition is detected in 51, or any other sensed parameter such as low flow is sensed in the flow transmitter 55. In these cases, the PLC will signal the power supply to stop operating.

[0076] The PLC can also cause the operation of the electrocoagulation to be paused, if for example a liquid level in a feed tank falls below the low level switch. In this case, the switch will open and the system will go into a pause mode where it will wait until there is sufficient fluid in the feed tank before automatically restarting the feed pump and the DC power supply.

[0077] In a further embodiment, the flow rate of the liquid entering the electrocoagulation system may be controlled by the power supply of the present invention. Referring to FIG. 10, the digital controller 21 of the power supply may automatically control the flow rate of the electrolyte or water entering the electrocoagulation cell. In operation, a user enters the desired flow rate set point 56 into the digital controller 21. The controller sends control signals to a variable speed AC motor drive 57 in order to achieve the flow rate set point. The variable AC motor drive 57 controls a feed pump motor 58, which varies the speed at which the pump operates. A feed tank 59 supplies the water or electrolyte that is to be pumped into the electrocoagulation cell 1.

[0078] The flow transmitter 55 measures the flow rate of the water being delivered to the electrocoagulation cell and transmits a signal back to the digital controller 21. The digital controller 21 then makes adjustments to its control signals in order to bring the measured flow rate to the flow rate set point entered by the user at 56. It will be appreciated that the flow rate of the electrolyte or water through an electrocoagulation cell may be of critical importance in the performance of the system.

[0079] The power supply may also control other functions associated with operation of the electrocoagulation system. For example, a cell drain control may be incorporated into the system whereby the cell is drained prior to cleaning, shut

down or maintenance. Similarly, the system may be actuated to facilitate cleaning the cell using a cleaning solution in which case no voltage will be applied between the electrodes.

[0080] The invention has been described with reference to exemplary embodiments. However, it should be noted that other embodiments are envisaged within the spirit and scope of the invention, for example the power supply for the 100 LPM system could be used for a flow rate of 500 LPM.

1. A control assembly for electrocoagulation cell comprising:

- a. a plurality of electrodes;
- b. releasable connection means between at least a selection of the electrodes comprising an elongate busbar which is arranged normal to respective top edges of each electrode in plan view and which extends through a notch, slot or aperture located in individual tabs which each extend upwardly from an adjacent top edge of each electrode whereby the busbar is spaced from the top edges of each electrode so as to avoid contact with liquid contained in the electrocoagulation cell in use as well as a plurality of fasteners attached to said busbar whereby each fastener abuts or is located closely adjacent to an adjoining surface of each electrode; and
- c. electrical connection means attached to the busbar at each end thereof which in use is connectable to a power supply.

2. A control assembly as claimed in claim 1 wherein the busbar is threaded and the plurality of fasteners comprise one or more threaded nuts each having an associated washer.

3. A control assembly as claimed in claim 1 wherein the electrical connection means comprises a power lead secured to an electrical connector having an aperture for engaging with an adjacent end of the busbar.

4. A control assembly as claimed in claim 3 wherein each electrical connector is attached to the busbar with a fastener on either side of the connector.

5. An electrocoagulation system comprising:

- a. a controller that is selectable for providing both a constant output current and/or a constant output voltage whereby the electrolytic cell may process samples of varying characteristics;
- b. a voltage regulator;
- c. a transformer having a primary coil connected to the voltage regulator;
- d. a rectifier connected to a secondary coil of the transformer; and
- e. a voltage or current regulator which receives an output from the rectifier and together with said controller effects a firing control of the voltage regulator.

6. An electrocoagulation system as claimed in claim 5 wherein the control means in a voltage and current potentiometer.

7. An electrocoagulation system as claimed in claim 6 wherein the potentiometer is set for a constant output DC current thereby allowing the power supply to provide a variable output DC voltage.

8. An electrocoagulation system as claimed in claim 6 wherein the potentiometer is set for a constant output DC voltage thereby allowing the power supply to provide a variable output DC current.

9. An electrocoagulation system as claimed in claim 5 which has an adjustable switch connectable to the power source and which is also connected to the voltage regulator.

10. An electrocoagulation system as claimed in claim 5 which further includes a polarity switch relay to select an output polarity.

11. An electrocoagulation system as claimed in claim 5 which further includes a current trip for protection against exceeding a maximum DC amperage rating of the power supply.

12. An electrocoagulation system as claimed in claim 5 which further includes an over temperature relay to sense any overheating in the rectifier.

13. An electrocoagulation system as claimed in claim 9 which comprises:

- (vi) an adjustable switch connectable to a power source;
- (vii) a voltage regulator connected to the switch;
- (viii) a transformer having a primary coil connected to the voltage regulator;
- (ix) a rectifier connected to a secondary coil of the transformer and;
- (x) said control means being connected between the switch and the voltage regulator to control a DC output applied to the electrolytic cell to have said selected constant current or said selected constant voltage.

14. A power supply as claimed in claim 13 which further includes a polarity switch relay to select an output polarity.

15. A power supply as claimed in claim 13 which further includes a voltage or current regulator which receives an output from the rectifier and together with said control means effects a firing control of the voltage regulator.

16. A power supply as claimed in claim 13 wherein said control means includes a voltage and current potentiometer.

17. A power supply as claimed in claim 13 which further includes a current trip for protection against exceeding a maximum DC amperage rating of the power supply.

18. A power supply as claimed in claim 13 which further includes an over temperature relay to sense any overheating in the rectifier.

* * * * *