



US 20060072109A1

(19) **United States**

(12) **Patent Application Publication**  
**Bodkin et al.**

(10) **Pub. No.: US 2006/0072109 A1**

(43) **Pub. Date: Apr. 6, 2006**

(54) **HYPERSPECTRAL IMAGING SYSTEMS**

**Related U.S. Application Data**

(76) Inventors: **Andrew Bodkin**, Wellesley, MA (US);  
**Andrew I. Sheinis**, Madison, WI (US);  
**Adam Norton**, Palo Alto, CA (US)

(60) Provisional application No. 60/607,327, filed on Sep. 3, 2004.

**Publication Classification**

(51) **Int. Cl.**  
**G01J 3/28** (2006.01)  
(52) **U.S. Cl.** ..... **356/328; 356/326**

Correspondence Address:  
**LATHROP & GAGE LC**  
**4845 PEARL EAST CIRCLE**  
**SUITE 300**  
**BOULDER, CO 80301 (US)**

(57) **ABSTRACT**

Hyperspectral imaging systems that may be used for imaging objects in three-dimensions with no moving parts are disclosed. A lenslet array and/or a pinhole array may be used to reimage and divide the field of view into multiple channels. The multiple channels are dispersed into multiple spectral signatures and observed on a two-dimensional focal plane array in real time. The entire hyperspectral datacube is collected simultaneously.

(21) Appl. No.: **11/220,016**

(22) Filed: **Sep. 6, 2005**

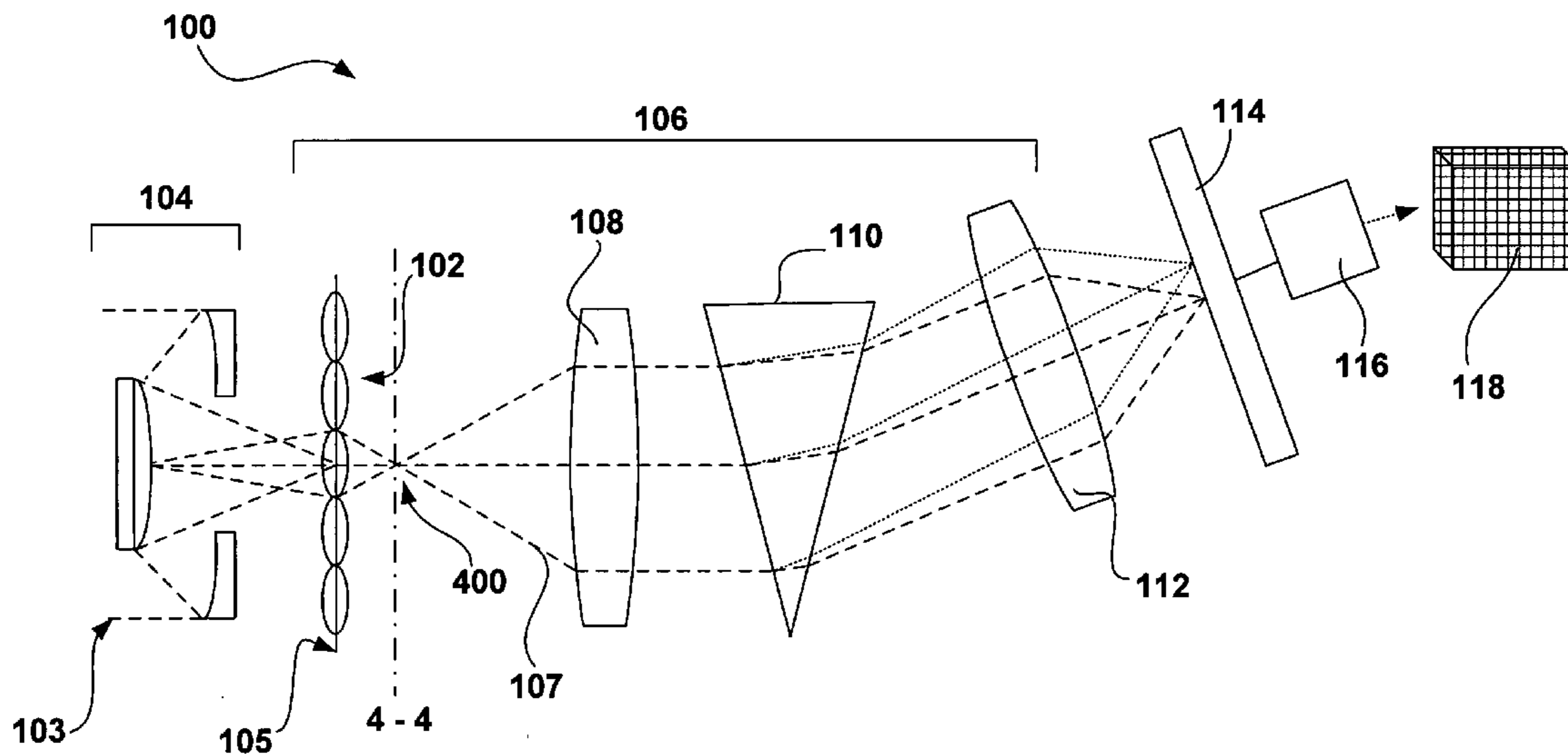

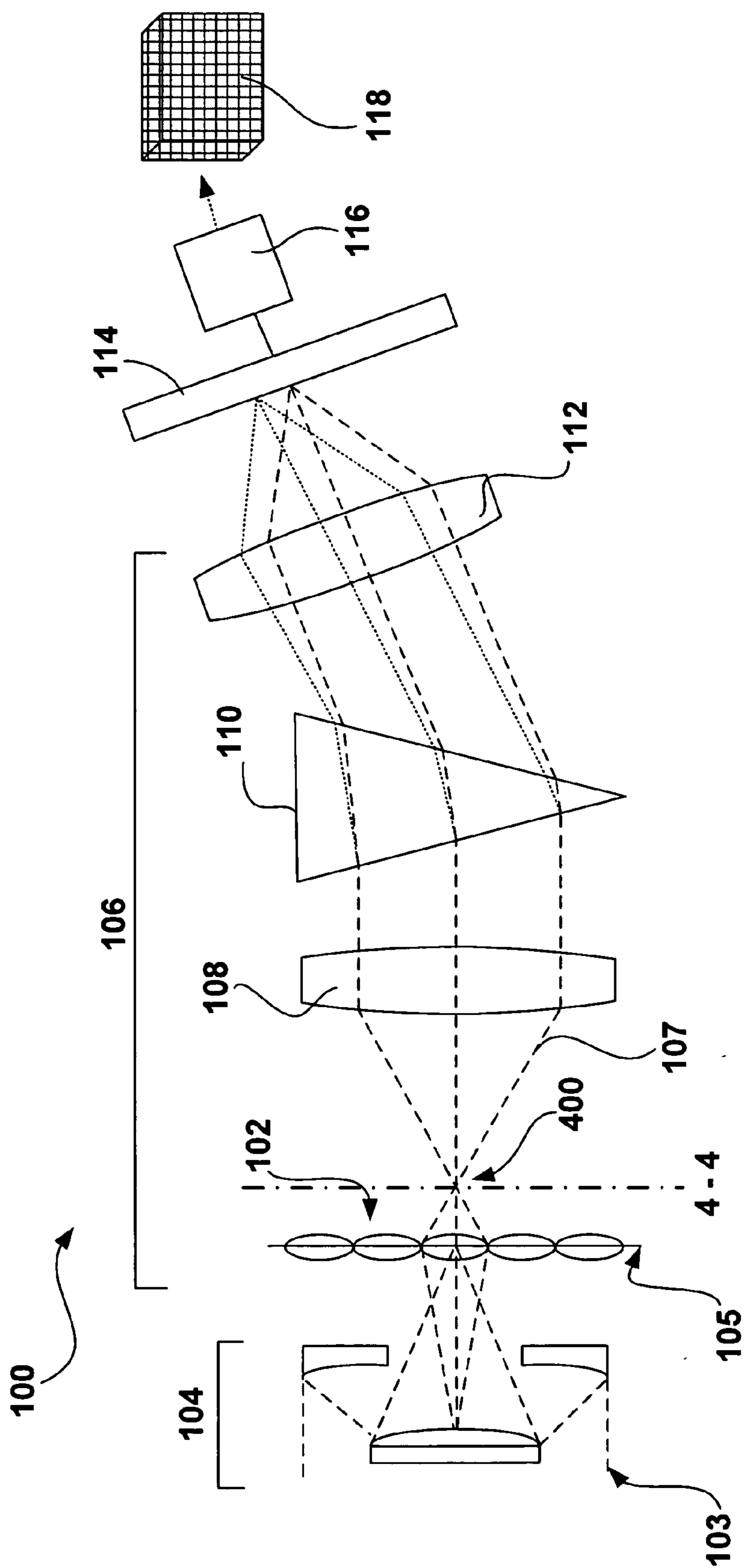

FIG. 1

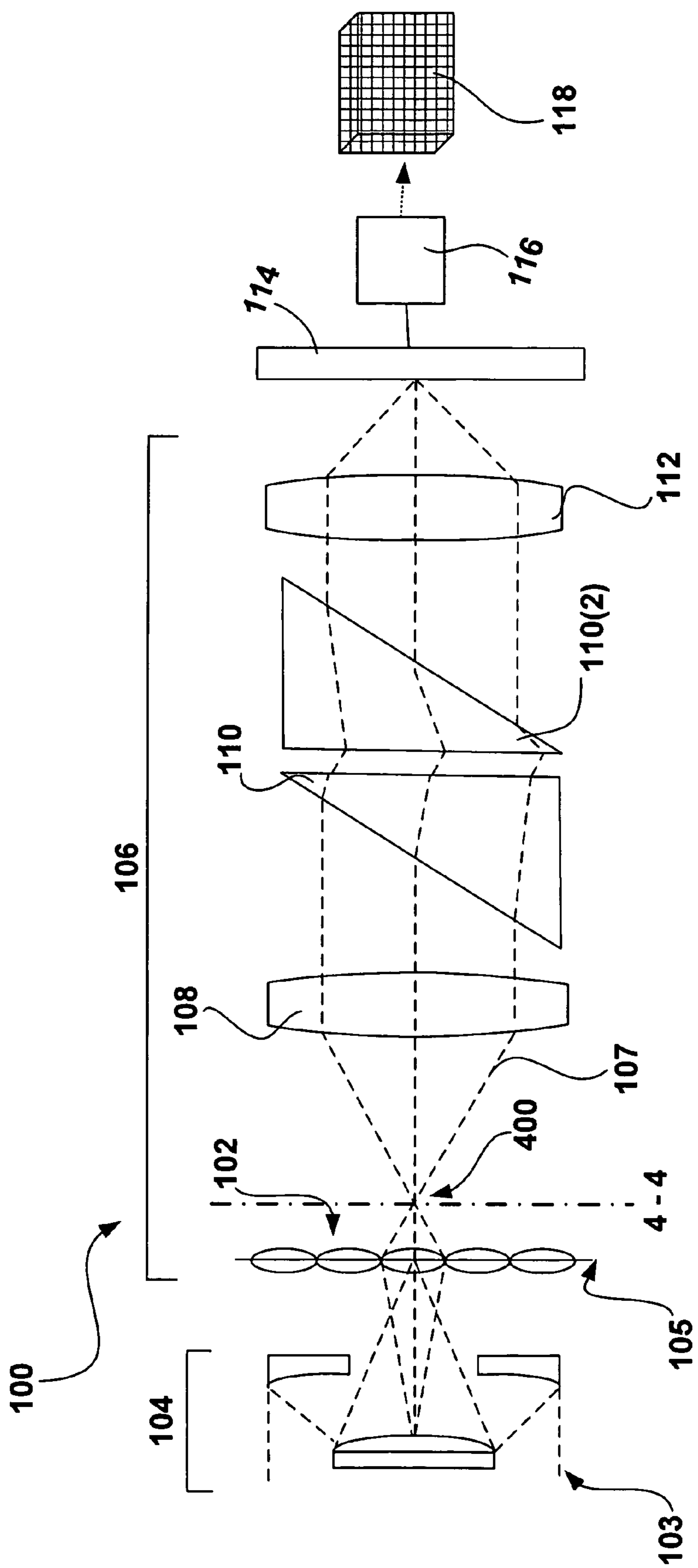
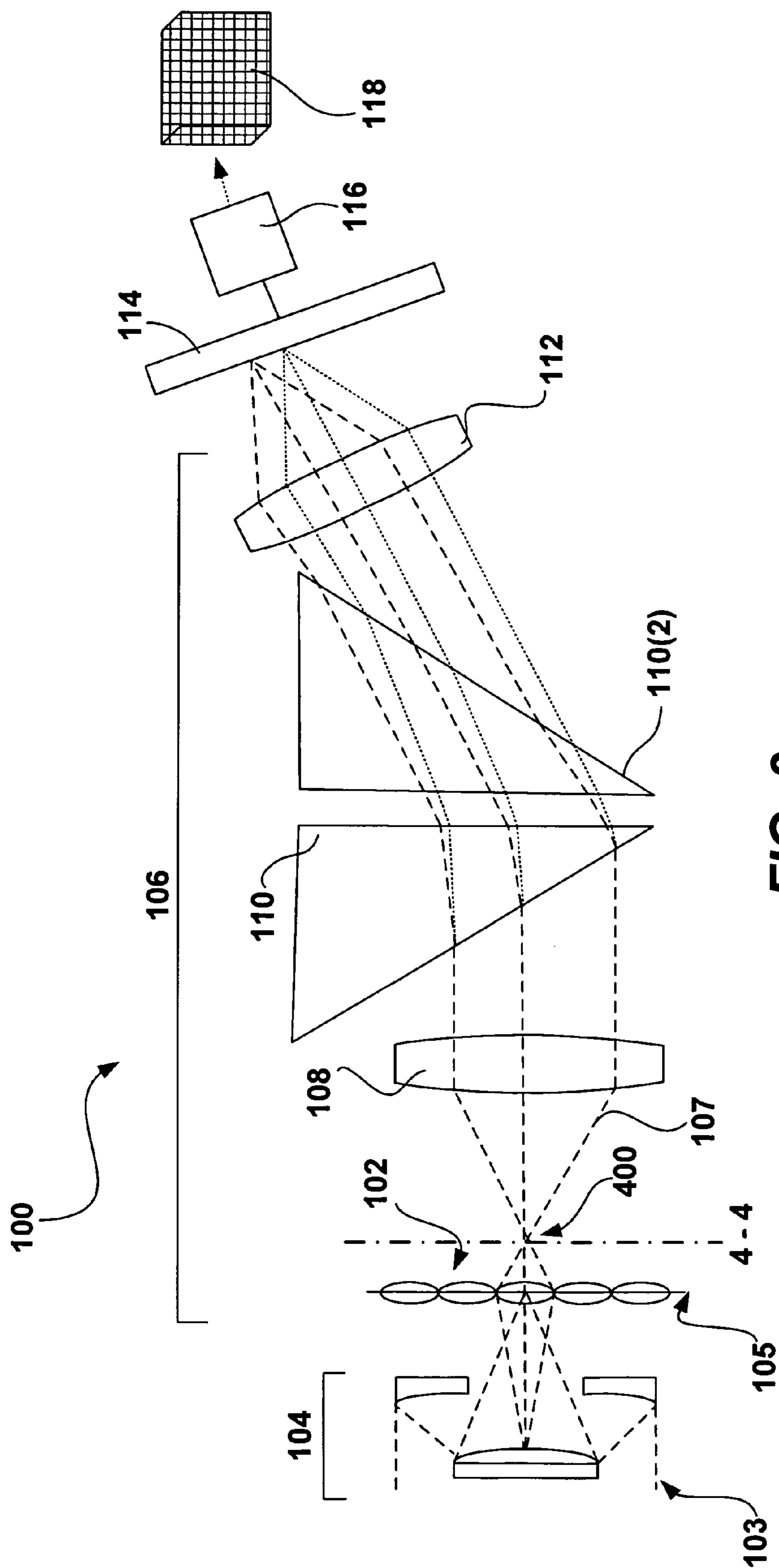
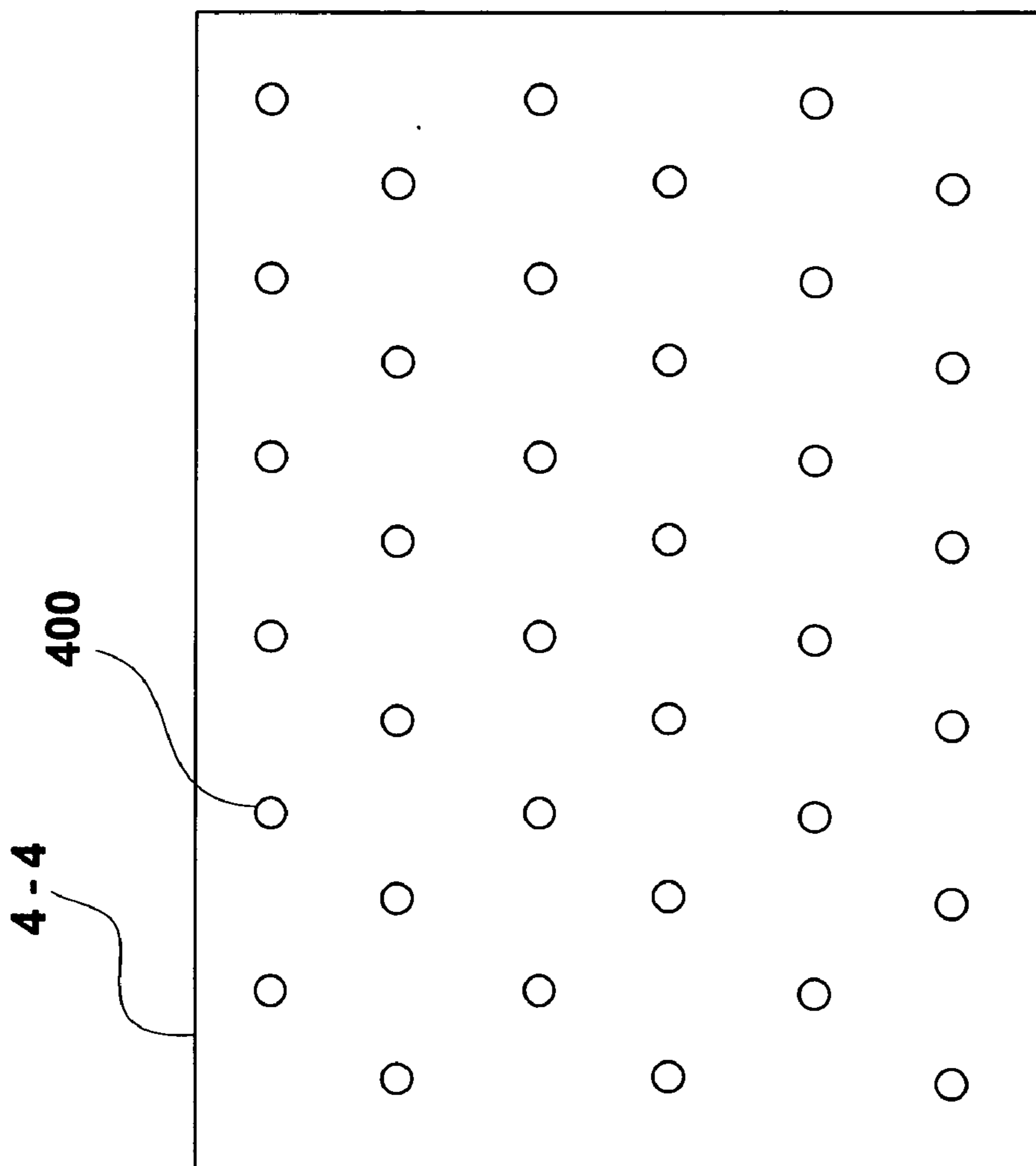

FIG. 2





**FIG. 4**

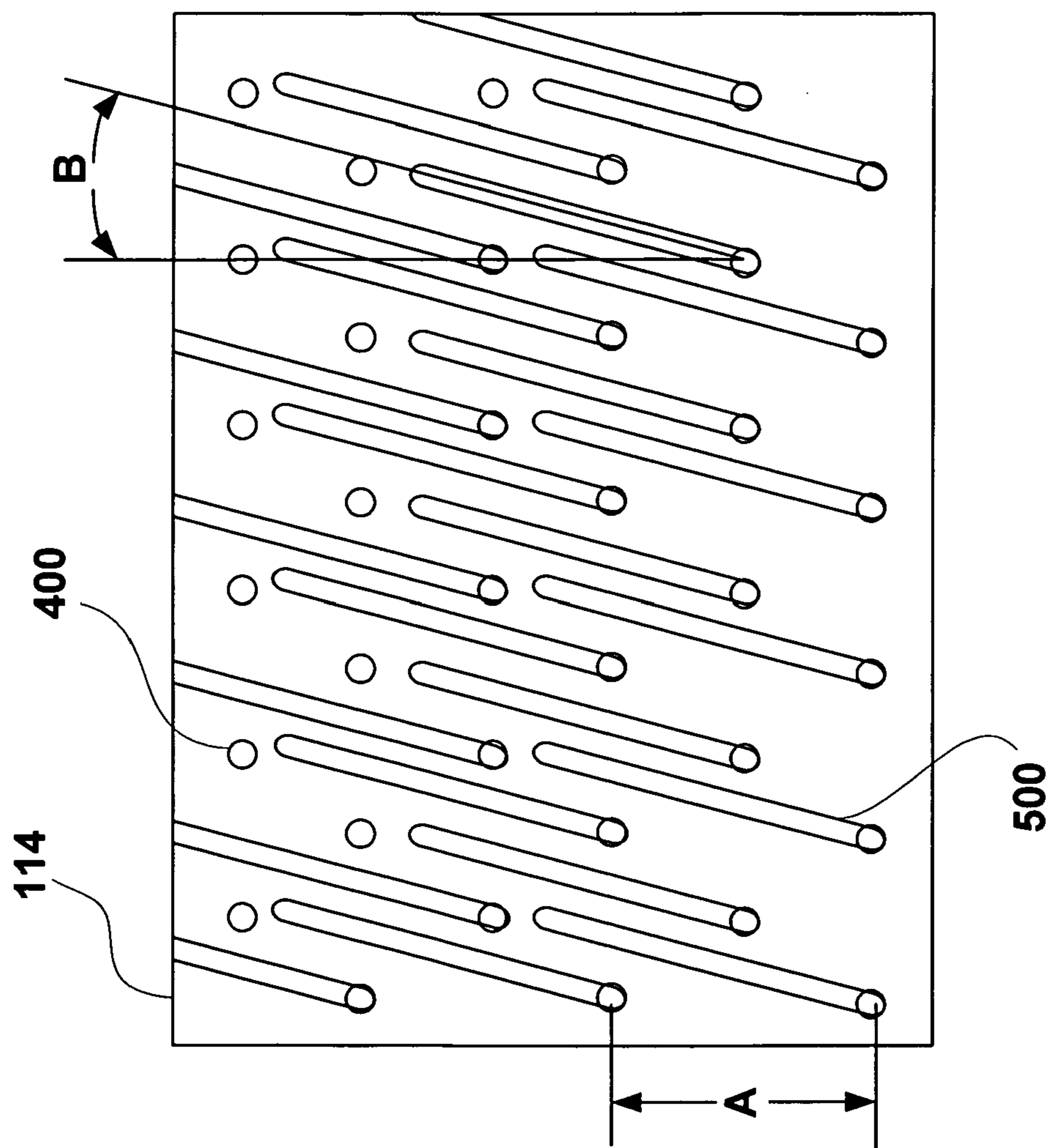
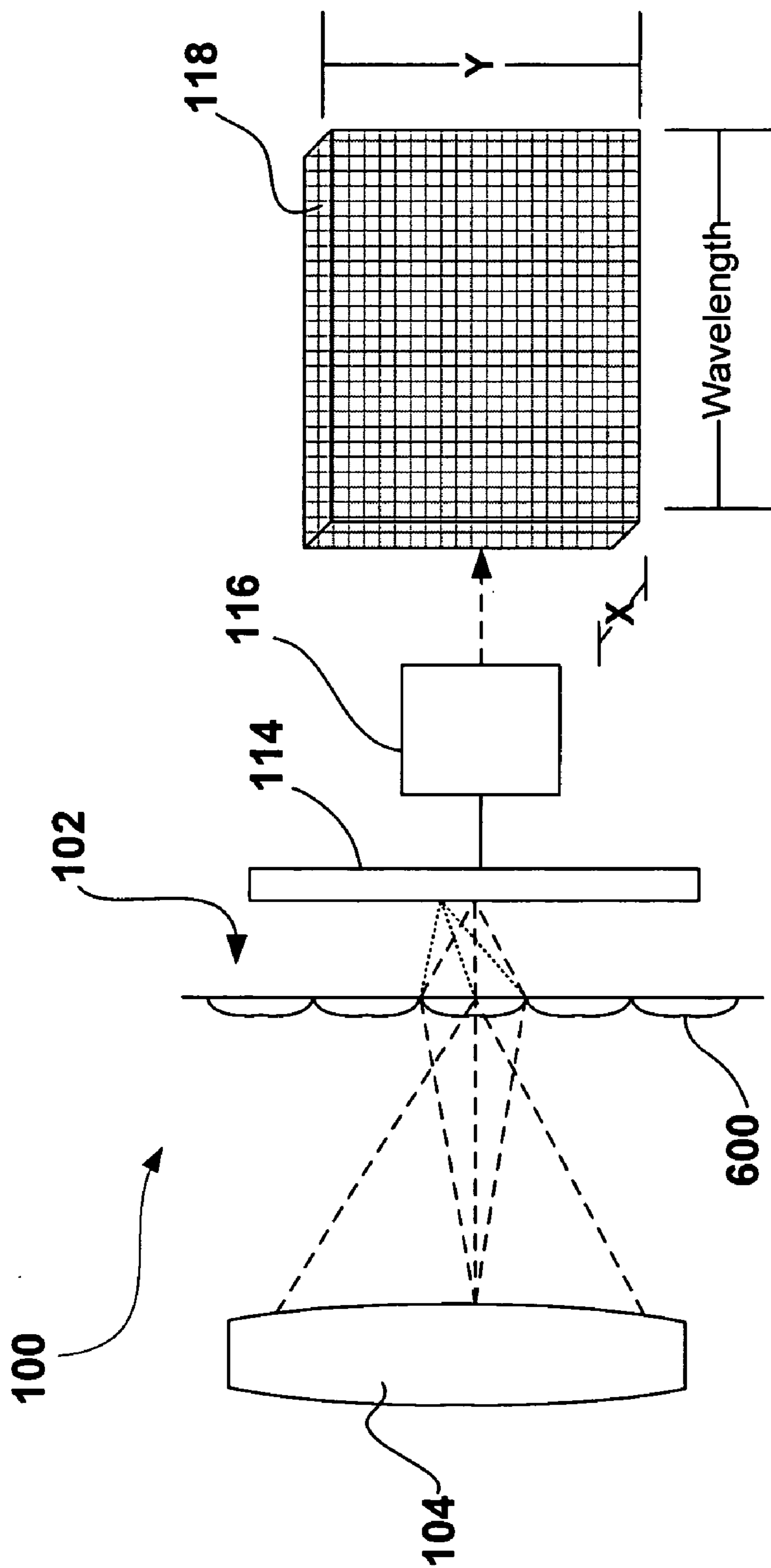
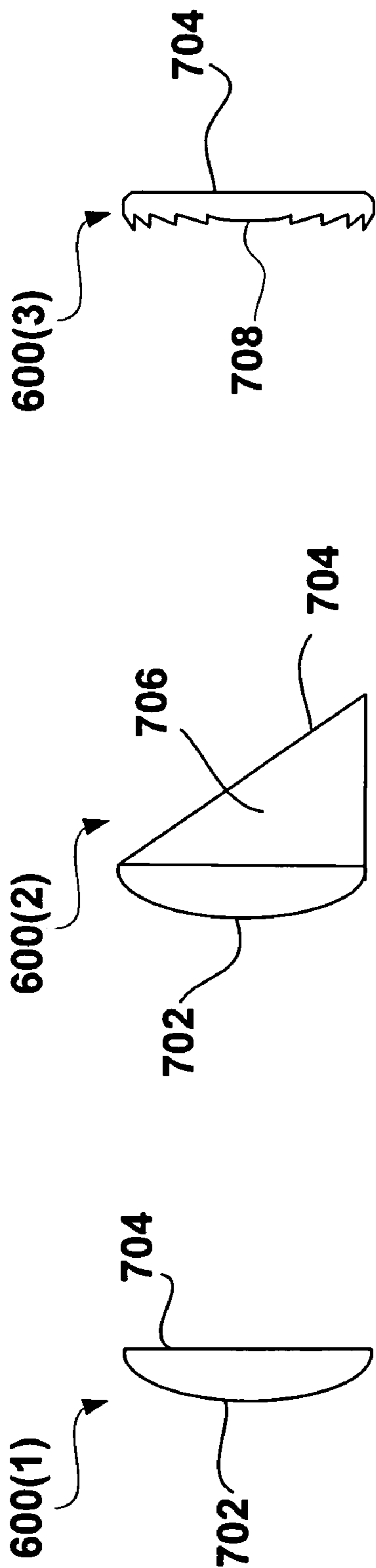

FIG. 5

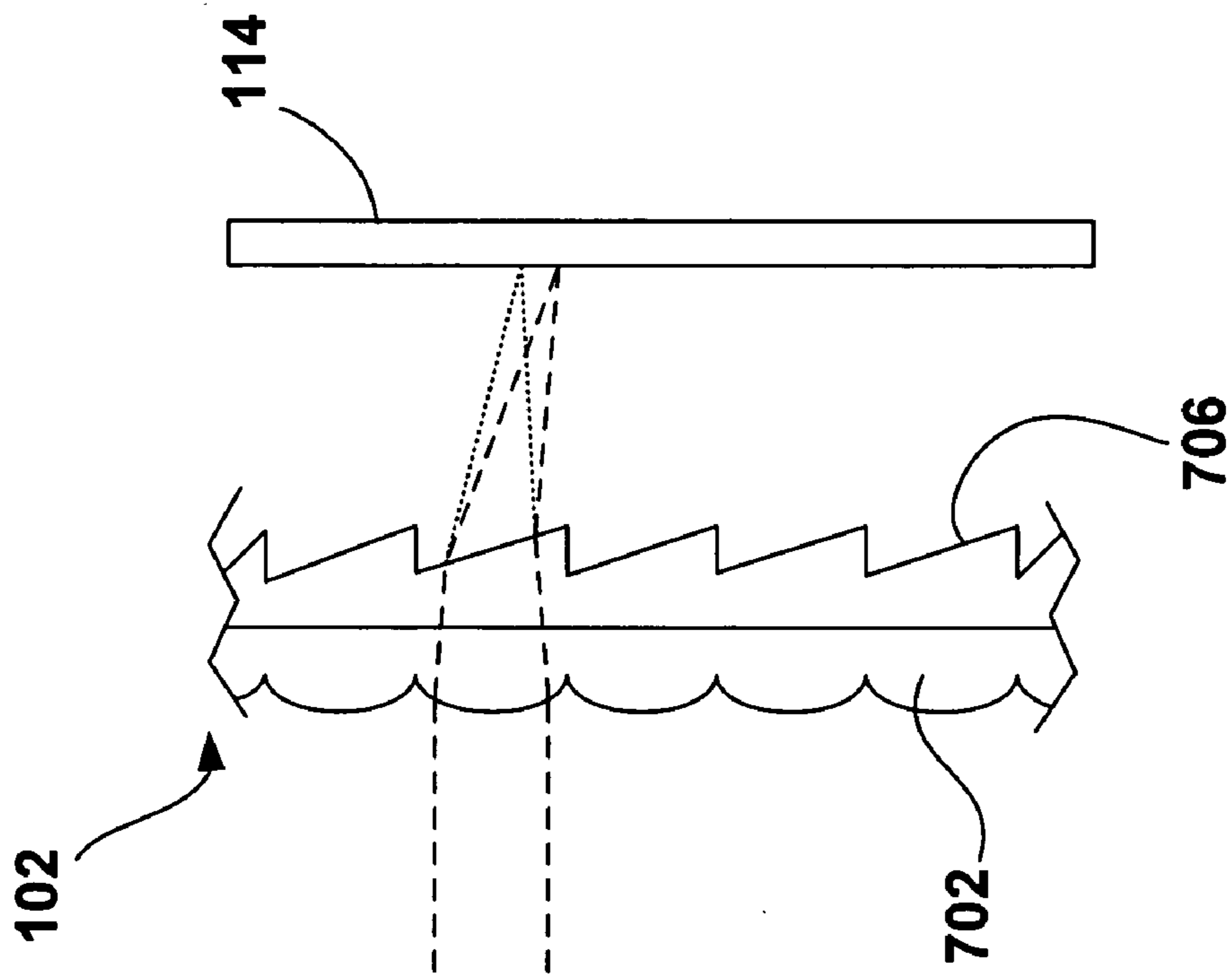

**FIG. 6**

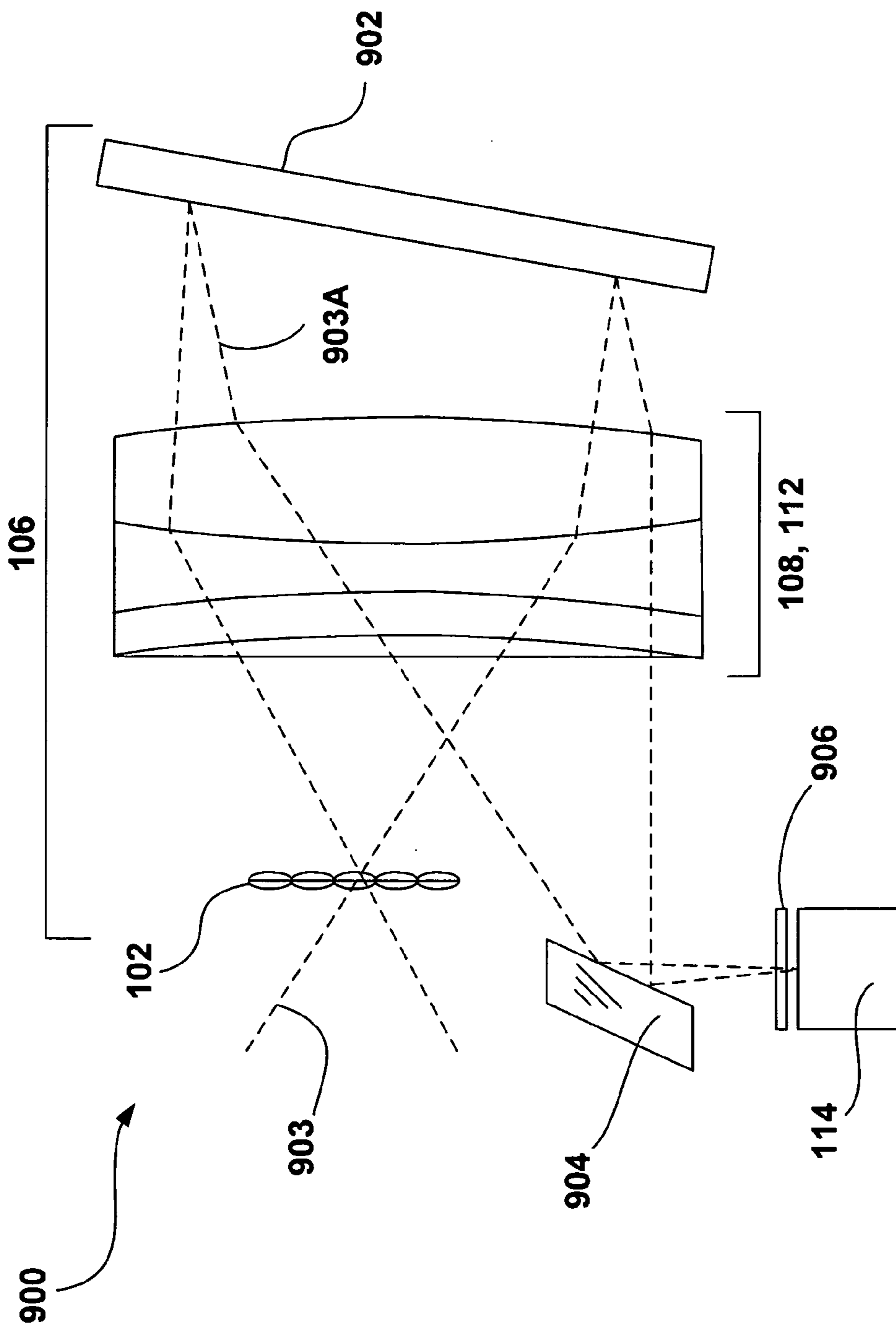

**FIG. 7**





**FIG. 8**



**FIG. 9**

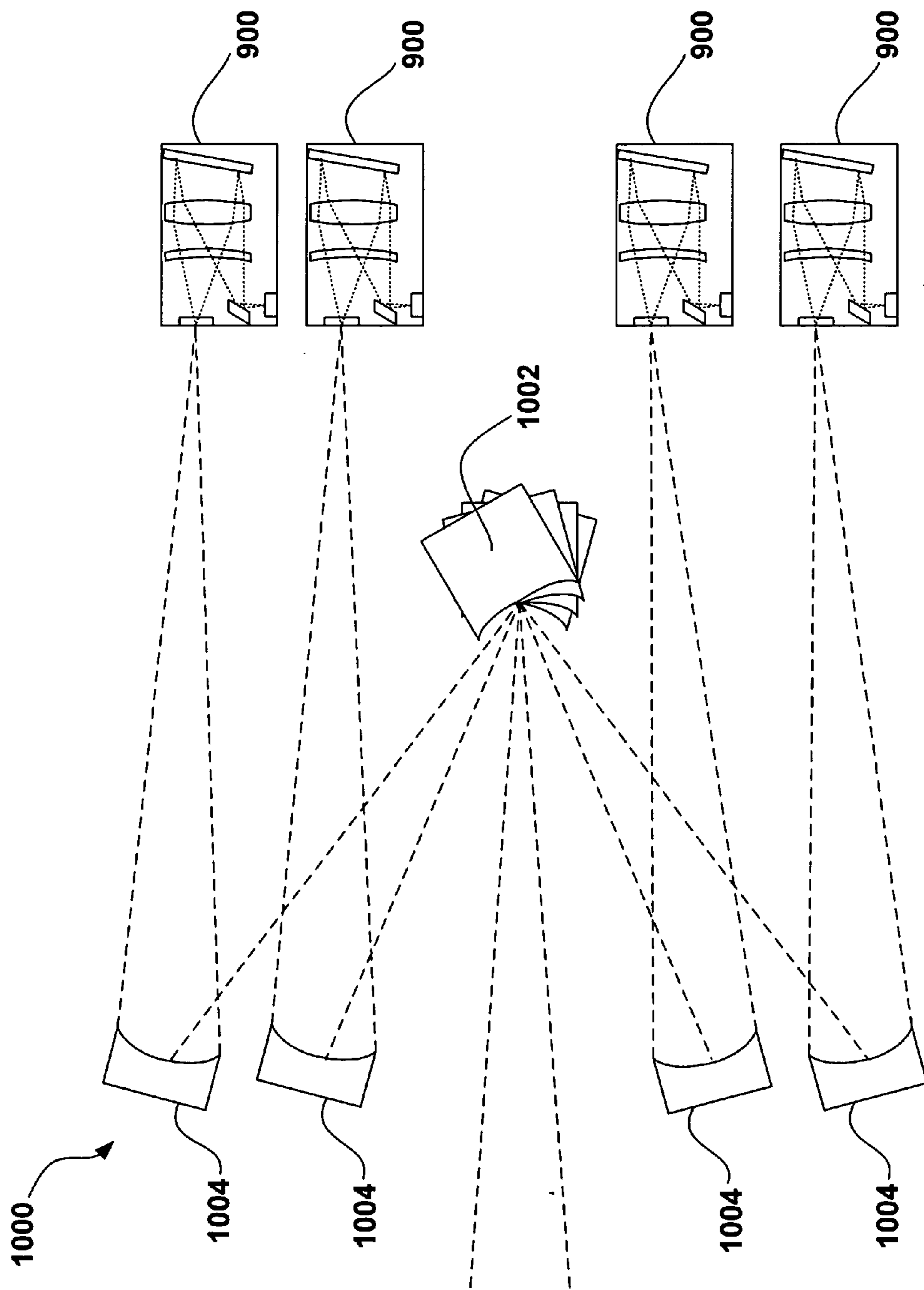
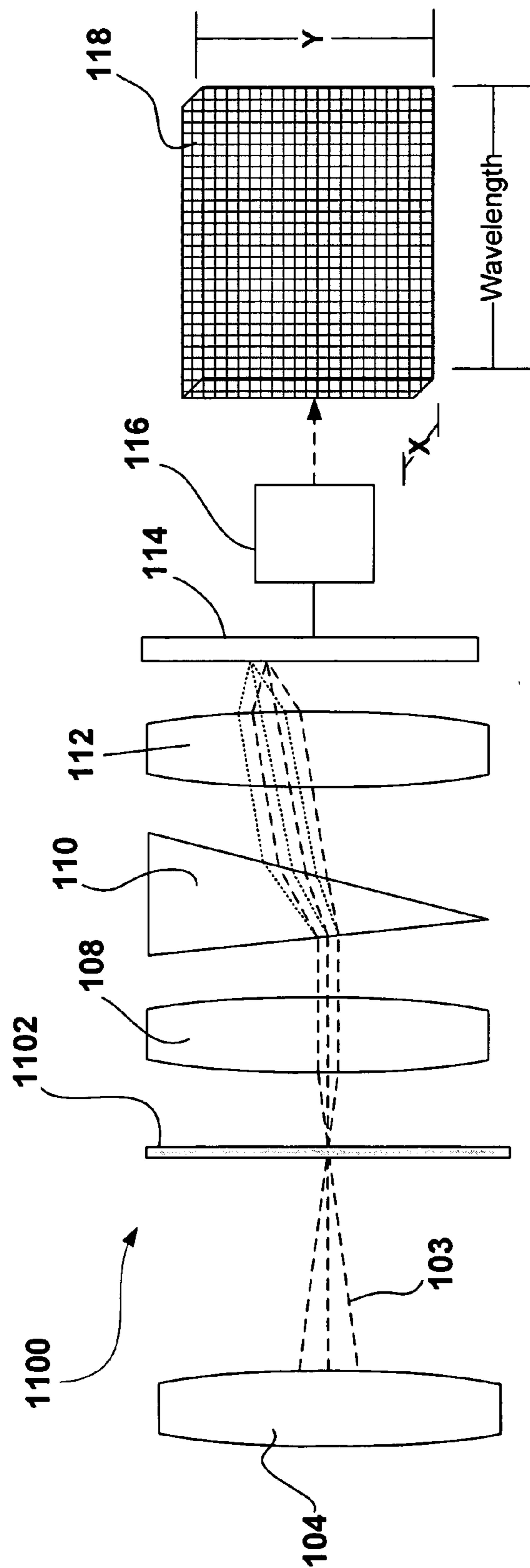

FIG. 10



**FIG. 11**

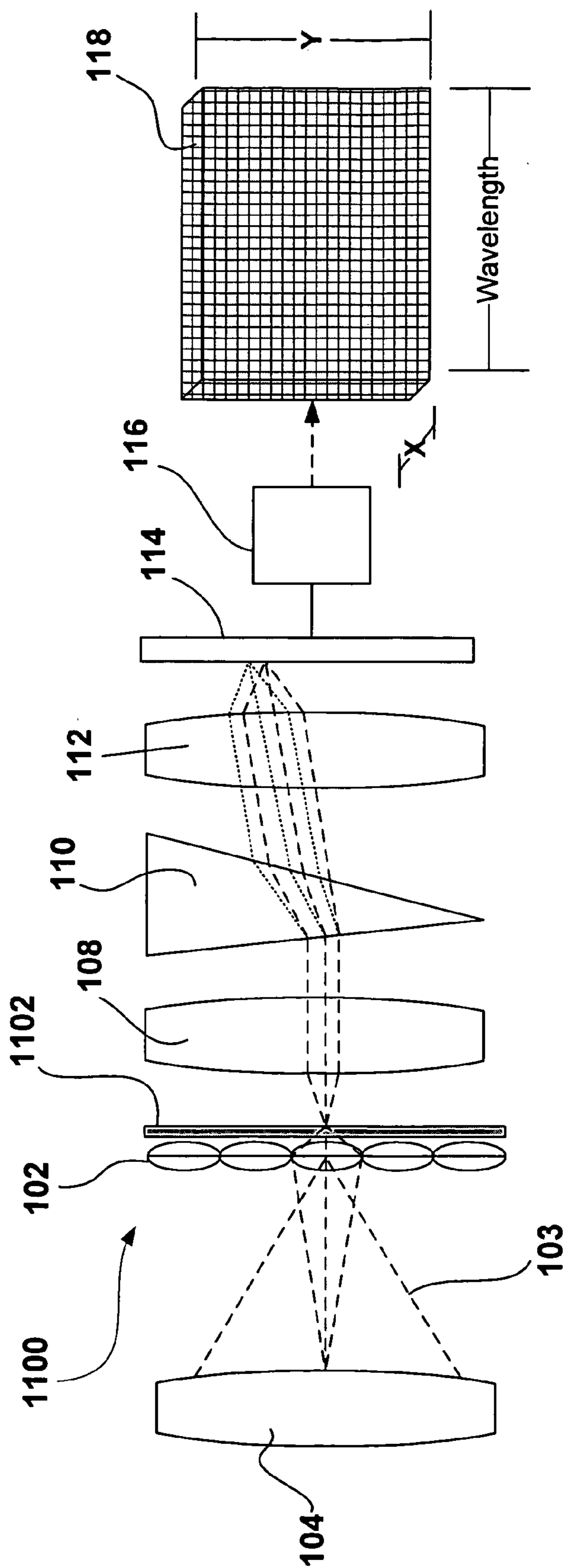
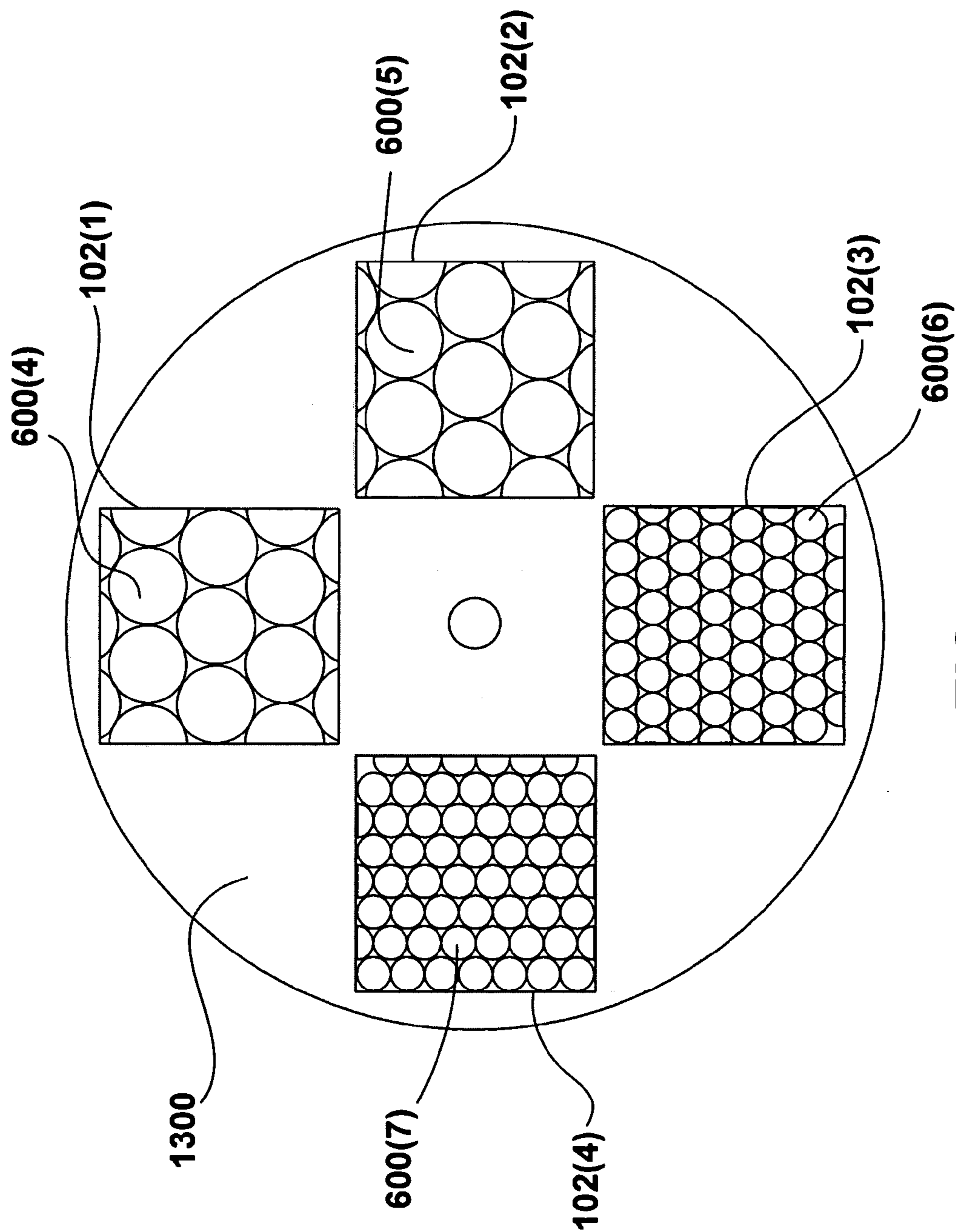

FIG. 12



**FIG. 13**

## HYPERSPECTRAL IMAGING SYSTEMS

### RELATED APPLICATIONS

[0001] This application claims priority to U.S. provisional application Ser. No. 60/607,327, filed Sep. 3, 2004 and incorporated herein by reference.

### U.S. GOVERNMENT RIGHTS

[0002] The U.S. Government has certain rights in this invention as provided for by the terms of Grant #F19628-03-C-0079 awarded by the U.S. Air Force.

### BACKGROUND

[0003] Hyperspectral imaging is a technique used for surveillance and reconnaissance in military, geophysical and marine science applications. Objects viewed by a hyperspectral imaging system are often displayed in three-dimensions,  $x$ ,  $y$  (spatial) and  $\lambda$  (color wavelength). Spatial observations ( $x$ ,  $y$ ) allow a person to observe an image when high contrast is available. However, during conditions of low contrast, such as fog, smoke, camouflage, and/or darkness, or when an object is too far away to resolve, spectral signatures help identify otherwise unobservable objects, for example to differentiate between friendly and enemy artillery.

[0004] The hyperspectral imaging technique typically employs a scanning slit spectrometer, although Fourier-transform imaging spectrometers (FTIS), and scanning filter (Fabry-Perot) imaging systems have also been used. These devices, however, record only two-dimensions of a three-dimensional data set at any one time. For example, the scanning slit spectrometer takes spectral information over a one-dimensional field of view (FOV) by imaging a scene onto a slit then passing that collimated image from the slit through a dispersive element (prism) and re-imaging various wavelength images of the slit onto a detector array. In order to develop three-dimensional information, the slit is scanned over the entire scene producing different images that must be positionally matched in post-processing. The FTIS and Fabry-Perot techniques also scan; the former scans in phase space, and the latter scans in frequency

[0005] Current scanning spectrometer designs have resulted in large, expensive and unwieldy devices that are unsuitable for hand-held or vehicle applications. While these spectrometers have been employed effectively in airborne and satellite applications, they have inherent design limitations. These limitations arise due to motion of the associated platform, motion or changes in the atmosphere, and/or motion of the objects in the image field that occur during scan sequences. Motion of the platform results in mismatched and misaligned sub-images, reducing the resolution and hence the effectiveness of the observations, while a moving object, such as a missile, may escape detection if the object is moving faster than the spectrometer scan rate.

### SUMMARY

[0006] In one embodiment, a hyperspectral imaging system includes a focal plane array and a grating-free spectrometer that divides a field of view into multiple channels and that reimages the multiple channels as multiple spectral signatures onto the detector array.

[0007] In one embodiment, a hyperspectral imaging system includes a lenslet array that divides a field of view into multiple channels, optics that collimate electromagnetic energy of the multiple channels from the lenslet array, a grating that disperses the multiple channels into multiple spectral signatures and that reflects the electromagnetic energy back through the optics, and a focal plane array that detects the multiple spectral signatures.

[0008] In one embodiment, a hyperspectral imaging system includes imaging optics that form an image of an object, a focal plane array, a lenslet array that forms multiple images of a pupil of the imaging optics, and a prism and grating coupled to the lenslet array, to disperse the multiple images as multiple spectral signatures onto the focal plane array while blocking, by total internal reflection within the prism, unwanted spectral orders.

[0009] In one embodiment, a hyperspectral imaging system is provided. Imaging optics form an image of an object. An image slicer partitions a field of view of the imaging optics. For each partitioned part of the field of view, a focal plane array and a spectrometer divide a portioned field of view into multiple channels and reimage the multiple channels as multiple spectral signatures onto the focal plane array.

[0010] In one embodiment, a multiwavelength imager is provided. Imaging optics form an image of an object. At least one micromachined optical element (MMO) is located at or near to an image plane of the imager, providing a spectral signature for use with a focal plane array.

[0011] In one embodiment, a hyperspectral imaging system includes imaging optics that form an image of an object. A spectrometer has an array of pinholes that divide a field of view of the imaging optics into multiple channels. Dispersive optics reimage the multiple channels as multiple spectral signatures onto a focal plane array.

[0012] In one embodiment, a hyperspectral imaging system includes a lenslet array, a focal plane array, a pinhole array between the detector array and the lenslet array. The pinhole array having a different pitch than the lenslet array and aligned such that each lenslet of the lenslet array corresponds to a pinhole of the pinhole array. The lenslet array is moveable to define where an object is viewed by the imaging system. A spectrometer reimages multiple channels from the lenslet array as multiple spectral signatures onto the detector array.

[0013] In one embodiment, a hyperspectral imager includes the improvement of at least one zoom lens for selecting a variable field of view of the imager and a variable dispersion element for selecting dispersion for spectral signatures for the imager.

[0014] In one embodiment, a hyperspectral imager of the type that forms a hyperspectral data cube includes the improvement of at least one zoom collimating or relay lens that variably adjusts spectral and spatial resolution of the hyperspectral data cube.

### BRIEF DESCRIPTION OF THE FIGURES

[0015] FIG. 1 illustrates a hyperspectral imaging system in accord with an embodiment.

[0016] FIG. 2 illustrates a hyperspectral imaging system including crossed prisms that produce minimal dispersion of electromagnetic energy in accord with an embodiment.

[0017] FIG. 3 illustrates a hyperspectral imaging system including crossed prisms that produce a large degree of dispersion in accord with an embodiment.

[0018] FIG. 4 illustrates an intensity pattern from a two-dimensional lenslet array.

[0019] FIG. 5 illustrates an intensity pattern of spectra spread from individual channels.

[0020] FIG. 6 illustrates a hyperspectral imaging system including a micromachined optical (MMO) assembly in accord with an embodiment.

[0021] FIG. 7 illustrates exemplary MMO's of FIG. 6.

[0022] FIG. 8 illustrates a cross-section of one MMO assembly in accord with an embodiment.

[0023] FIG. 9 illustrates a hyperspectral imaging system including a reflective grating in accord with an embodiment.

[0024] FIG. 10 illustrates a hyperspectral imaging system including an image slicer in accord with an embodiment.

[0025] FIG. 11 illustrates a hyperspectral imaging system including a pinhole array in accord with an embodiment.

[0026] FIG. 12 illustrates a hyperspectral imaging system including a lenslet array and a pinhole array in accord with an embodiment.

[0027] FIG. 13 illustrates an assembly wheel incorporating various MMOs in accord with an embodiment.

#### DETAILED DESCRIPTION

[0028] A hyperspectral imaging system is disclosed herein which may achieve high instrument resolution by recording three-dimensions, two spatial dimensions (x and y) and a spectral or color dimension ( $\lambda$ ), simultaneously. Further, the hyperspectral imager may be handheld and operate to disperse and refocus an image without using moving parts. The imaging optics may for example image faster than at least f/5.

[0029] A hyperspectral imaging system 100 is shown in FIG. 1. System 100 uses a two-dimensional lenslet array 102 at or near to an image plane 105 of imaging optics 104, to resample an image formed by imaging optics 104; lenslet array 102 is part of a spectrometer 106, discussed in more detail below. Imaging optics 104 are illustratively shown as a Cassegrain telescope but may instead comprise optical elements (e.g., as in FIG. 6) including refractive optical elements. Accordingly, imaging optics 104 may be a camera lens or other optical system that customizes imaging specifications by modifying f-number, modifying magnification, providing cold shielding, and/or providing filtering. Imaging optics 104 are illustratively shown imaging incoming electromagnetic radiation 103 onto image plane 105.

[0030] Spectrometer 106 divides the image from imaging optics 104 into multiple channels, where each channel forms a pupil image that is focused as a spot 400 in an image plane 4-4 of lenslet array 102, as shown in FIG. 4. One exemplary channel 107 is shown in FIG. 1. In addition to lenslet array 102, spectrometer 106 includes a collimating lens 108, a

dispersive element 110, and a focusing lens 112. Dispersive element 110 is, for example, a prism that separates spots 400 into multiple spectral signatures. A second dispersive element 110(2), as shown in FIGS. 2 and 3, may be used to vary the diffractive power of the first dispersive element 110; for example, dispersive elements 110 and 110(2) may form a pair of crossed prisms where one of the dispersive elements may be rotated relative to the other in order to increase or decrease dispersion. FIG. 2 illustrates a hyperspectral imaging system having crossed prisms 110, 100(2) that produces minimal dispersion of electromagnetic energy. FIG. 3 illustrates a hyperspectral imaging system having crossed prisms 110, 100(2) that produces a large dispersion of electromagnetic energy.

[0031] Those skilled in the art, upon reading and fully appreciating this disclosure, will appreciate that elements 108, 112 of FIG. 1 may comprise additional or different types of optical elements (e.g., mirrors) to form like function, without departing from the scope hereof.

[0032] As illustrated in FIG. 4, each spectral signature is associated with a single spot 400 (each spot 400 from a corresponding lenslet of array 102) and is recorded simultaneously on a two-dimensional focal plane array 114. In one example, images are spread into several hundred color bands and about 1,000 spatial locations on a 100x100 CCD detector. A CCD detector may be used for detection in the visible region, while various other detectors may be used for detection in other parts of the electromagnetic spectrum, e.g., ultraviolet (UV), near infrared (NIR), mid-wave infrared (MWIR), long-wave infrared (LWIR) and/or microwave regions. Spectrometer 106 may thus be formed of optical elements that transmit and function in a particular waveband. An uncooled microbolometer may be used as focal plane array 114 when the waveband is infrared (e.g., 8-12 microns), for example.

[0033] The images received by focal plane array 114 are captured by a computer processor 116 and both the location of an image and the spectral information for that location are processed into a three-dimensional data set denoted herein as a hyperspectral data cube 118. The data are collected in parallel and may be saved to memory and/or viewed in real time in any of the several hundred wavebands recorded. Data cubes 118 are collected at the speed of the digital detector array, typically limited by its internal digital clock. Thus data cubes may be read, for example, at a rate between 1-1000 data cubes per second with a spectral resolution in a range of about 1-50 nm, for example.

[0034] As illustrated in FIG. 5, the dispersing direction (i.e., angle of dispersive element 110 relative to focal plane 114) may be rotated about the optical axis to avoid overlap of different spectra 500 on detector 114. Tilt angle B allows the spectral images to tilt between each other along the pixel separation distance A. For example, tilt angle B may range from about 10 to 20 degrees. The length of spectrum 500 is determined by the diffracting power of dispersive element(s) 110 and/or by a filter (see, e.g., FIG. 9). Accordingly, spectral resolution may be traded for spatial resolution and vice versa. For a given detector size, the number of spectral bands may be doubled, for example, by increasing the dispersion of the prism and halving the lenslet-array size (and, hence, halving the number of spatial lenslet elements). A zoom collimating or relay lens may also be used to variably adjust spectral and spatial resolution.



[0035] Referring again to **FIG. 1**, imaging optics **104** may be omitted from the hyperspectral imager in certain applications; in this embodiment, therefore, lenslet array **102** and a pinhole array serve to image the object as the multiple channels through the spectrometer **106**. See, e.g., **FIG. 9**.

[0036] **FIG. 6** shows each optic of lenslet array **102** as a micromachined optical element (“MMO”) **600** that both disperses and refocuses light. Expanded cross-sectional views of several exemplary MMO’s are shown in **FIG. 7**. For example, MMO **600(1)** may include a lens **702** coupled to a transmissive grating **704** (although grating **704** is shown on the back of lens **702**, it may instead be on the front of lens **702**). In another example, MMO **600(2)** includes a lens **702** coupled to a prism **706** and a transmissive grating **704**. Prism **706** may be configured to block a selected order by total internal reflection within the prism, but yet allow other spectral orders to be transmitted through lens **702** and diffracted by transmissive grating **704**. See, e.g., **FIG. 8**. In yet another example, a Fresnel lens **708** is coupled with a transmissive grating **704** as part of MMO **600(3)**.

[0037] The use of MMO’s may reduce the overall size and complexity of the hyperspectral imaging system, as well as increase the durability of the instrument using the hyperspectral imaging system, because there are no moving parts. Since the MMO’s are micromachined they are ideally suited for manufacturing in silicon for use in infrared imagers. Alternatively, using a low cost replicating technique, the MMO’s may be molded into epoxy on glass, for use in the visible waveband. Gratings may be applied to the MMO’s during the molding process or by chemical etching, photolithography and the like.

[0038] **FIG. 8** illustrates a cross-section of lenslet array **102** having lenses **702** for receiving and refocusing radiation. Each lens **702** is coupled with a prism **706** (and/or grating) that disperses radiation into its constituent wavelengths (spectral signature) onto focal plane array **114**.

[0039] **FIG. 9** illustrates a hyperspectral imaging system **900** including a reflective grating **902**. Electromagnetic energy **903** may be received directly by lenslet array **102** or transmitted through imaging optics **104** (not shown). Lenslet array **102** images and divides a field of view into multiple channels that are transmitted through spectrometer **106**, which illustratively includes both collimator **108** and focusing lens **112**. Spectrometer **106** may, for example, be an aspheric optical component manufactured of transmissive germanium, to operate in the infrared. Electromagnetic energy transmitted through spectrometer **106** is reflected and diffracted by reflective grating **902**, which is for example used in a Littrow configuration. The reflected electromagnetic energy **903A** is transmitted back through spectrometer **106** and reflected by a fold mirror **904** through a filter **906** onto a focal plane array **114**. Filter **906** may, for example, limit spectral length  $\lambda$  (**FIG. 5**) and prevent spectral overlap on detector **114**.

[0040] **FIG. 10** illustrates a hyperspectral imaging system **1000** including an image slicer **1002**. Image slicer **1002** divides an image received from imaging optics **104**. In the embodiment of **FIG. 10**, each slice of electromagnetic energy intersects a reflective element **1004** that transmits its associated energy to a designated spectrometer and detector combination. For example, the spectrometer/detector combination may be that of hyperspectral imaging system **900**,

although other hyperspectral imaging systems may be employed. Use of lenslet array **102** in combination with image slicer **1002** produces a two-dimensional field of view divided into multiple channels that can be dispersed by a grating without order overlap.

[0041] **FIG. 11** illustrates a hyperspectral imaging system **1100** including a pinhole array **1102**. Pinhole array **1102** may be used in place of, or in addition to, lenslet array **102** to divide the image into multiple channels through pinholes. Pinhole array **1102** may be positioned at or near to the image plane of imaging optics **104**. In one embodiment, pinhole array **1102** is moveable so that pinhole array **1102** is positioned to capture selective field positions of the object sampled by system **1102**. If pinhole array **1102** is positioned near to, but not at the image plane, then defocus energy transmits through pinholes of array **1102** such that integration of field positions occurs through the several channels of system **1100**. Pinhole array **1102** may be reflective to act as a narcissus mirror, to reduce background radiation in the case of infrared imaging. Similarly, pinhole array **1102** may be absorbing and cooled to reduce background radiation, which is particularly beneficial when the waveband sampled by the spectrometer is in the infrared. A collimating lens **108**, dispersive element **110**, and focusing lens **112** may be used in conjunction with pinhole array **1102** to disperse and refocus multiple channels into multiple spectral signatures on focal plane array **114**.

[0042] **FIG. 12** illustrates a hyperspectral imaging system including lenslet array **102** and pinhole array **1102**. Lenslet array **102** may be located between the object and pinhole array **1102** with each lens **600** of lenslet array **102** aligned with a corresponding pinhole of pinhole array **1102**. The pitch of lenslet array **102** and pinhole array **1102** are the same when imaging optics **104** is present, i.e., each pinhole is located at the optical axis of a lens **600**. If imaging optics **104** is not present within system **1100**, electromagnetic energy **103** may be directly sampled by lenslet array **102** and pinhole array **1102** by differing the pitch between lenslet array **102** and pinhole array **1102**. The pitch between lenslet array **102** and pinhole array **1102** are made to differ by offsetting the optical axis of one array relative to the other.

[0043] Multiple hyperspectral imagers may be used to cover a large field of view. For example, the exterior of a surveillance plane may be covered with multiple hyperspectral imagers. Data from the multiple imagers may be compiled into one comprehensive data set for viewing and analysis.

[0044] Alternatively, a large-scale hyperspectral imager may be fabricated according to the present instrumentalities. For example, a large-scale imager may be used in aerial or satellite applications. The costs of fabricating and transporting an imager as herein disclosed may be less than similar costs associated with a traditional hyperspectral imaging system due to the decreased number of optical components and weight thereof.

[0045] A large degree of flexibility is available where, for example, imaging optics, lenslet arrays, pinhole arrays, detectors, filters, and the like may be interchanged as necessary for a desired application of the hyperspectral imaging system. In one embodiment, illustrated in **FIG. 13**, a micromachined optical (MMO) assembly wheel **1300** for positioning multiple MMO’s formed into lenslet arrays **102**

within the imaging system is provided. Selection of any one lenslet array **102** provides differing spectral signatures from any other lenslet array of MMO wheel **1300**. For example, lenslet arrays **102(1)** and **102(2)** provide hexagonally packed MMO's **600(4)** and **600(5)**, respectively. However, MMO's **600(5)** may include different optical components, i.e., filters, gratings and/or prisms, than MMO's **600(4)**. Lenslet arrays **102(3)** and **102(4)** provide close packed hexagonal arrangements of MMO's **600(6)** and **600(7)**, respectively, and the optical components of MMO's **600(6)** and **600(7)** may differ. MMO's **600(4)** and **600(5)** are larger than MMO's **600(6)** and **600(7)**. Large MMO's may provide for decreased spatial resolution, but increased spectral resolution.

[0046] It is also possible that lenses **600**, that are not coupled with gratings **704** or prisms **706**, may be utilized in a MMO wheel **1300**. It may then be desirable to vary the amount of dispersion to accommodate various lens sizes. For example, dispersive element(s) **110** may be rotated to increase dispersion when large lenses **600** are used and decrease dispersion when small lenses **600** are used to sample an image. Zoom lenses may also be used beneficially with differing MMOs within the hyperspectral imaging system.

[0047] Object identification, which is more than mere recognition, may be performed by software to distinguish objects with specific spatial and spectral signatures. For example, materials from which objects in the image are made may be spectrally distinguished, e.g., in the visible range, paint on an enemy tank may be distinguished from paint on a friendly tank, while in the infrared region, a water treatment plant may be distinguished from a chemical weapons factory. The software may be trained to color code or otherwise highlight elements of the image with particular spatial and/or spectral signatures.

[0048] Certain changes may be made in the systems and methods described herein without departing from the scope hereof. It should thus be noted that the matter contained in the above description or shown in the accompanying drawings should be interpreted as illustrative and not in a limiting sense. The following claims are intended to cover all generic and specific features described herein, as well as all statements of the scope of the present method and system, which, as a matter of language, might be said to fall there between.

What is claimed is:

1. A hyperspectral imaging system, comprising:
  - a focal plane array; and
  - a grating-free spectrometer for dividing a field of view into multiple channels and for reimaging the multiple channels as multiple spectral signatures onto the focal plane array.
2. The system of claim 1, further comprising imaging optics for forming an image of an object within the field of view.
3. The system of claim 2, wherein the grating-free spectrometer comprises an array of pinholes dividing the field of view of the imaging optics to form the multiple channels, the pinholes being positioned adjacent to an image formed by the imaging optics, to blur energy from the image of the object into at least one of the channels.

4. The system of claim 2, wherein the grating-free spectrometer comprises a lenslet array and an array of pinholes to sample the image.

5. The system of claim 4, wherein the imaging optics image faster than at least f/5.

6. The system of claim 2, wherein the grating-free spectrometer comprises an array of pinholes dividing the field of view of the imaging optics to form the multiple channels.

7. The system of claim 6, the pinholes formed by a narcissus mirror with an array of apertures, to reduce background radiation onto the focal plane array.

8. The system of claim 6, the pinholes formed by an optically absorbing material with an array of apertures, the absorbing material being cooled to reduce background radiation onto the focal plane array.

9. The system of claim 1, the grating-free spectrometer comprising: (a) a lenslet array, to form the multiple channels; (b) optics, to collimate electromagnetic energy of the multiple channels from the lenslet array; (c) a prism, to disperse the electromagnetic energy of the multiple channels into multiple spectral signatures; and (d) optics to image the spectral signatures onto the focal plane array.

10. The system of claim 9, wherein the grating-free spectrometer comprises an array of pinholes dividing the field of view of the imaging optics to form the multiple channels.

11. The system of claim 10, the pinholes formed by a narcissus mirror with an array of apertures, to reduce background radiation onto the focal plane array.

12. The system of claim 10, the pinholes formed by an optically absorbing material with an array of apertures, the absorbing material being cooled to reduce background radiation onto the focal plane array.

13. The system of claim 1, further comprising a processor connected with the focal plane array for forming a hyperspectral data cube from the multiple spectral signatures, wherein objects may be identified from the hyperspectral data cube.

14. The system of claim 1, the grating-free spectrometer comprising: first optics for collimating electromagnetic energy of an object along an optical axis; a first prism for dispersing the electromagnetic energy; a second prism for redirecting the spectra of the first prism along the optical axis; second optics for focusing electromagnetic energy along the optical axis from the second prism and onto the focal plane array.

15. A hyperspectral imaging system, comprising:

- a lenslet array for dividing a field of view into multiple channels;

- optics for collimating electromagnetic energy of the multiple channels from the lenslet array;

- a grating for dispersing the multiple channels into multiple spectral signatures and for reflecting the electromagnetic energy back through the optics; and

- a focal plane array for detecting the multiple spectral signatures.

16. The system of claim 15, further comprising imaging optics for forming an image of an object within the field of view.

- 17.** A hyperspectral imaging system, comprising:  
 imaging optics for forming an image of an object;  
 a focal plane array;  
 a lenslet array for forming multiple images of a pupil of the imaging optics; and  
 a prism and grating coupled to the lenslet array, for dispersing the multiple images as multiple spectral signatures onto the focal plane array while blocking, by total internal reflection within the prism, unwanted spectral orders.
- 18.** A hyperspectral imaging system, comprising:  
 imaging optics for forming an image of an object;  
 an image slicer for partitioning a field of view of the imaging optics; and, for each partitioned part of the field of view:  
 a focal plane array; and a spectrometer for dividing a portioned field of view into multiple channels and for reimaging the multiple channels as multiple spectral signatures onto the focal plane array.
- 19.** The system of claim 18, further comprising an array of pinholes configured to sample the image and divide the field of view to form the multiple channels.
- 20.** The system of claim 19, further comprising a lenslet array, wherein each lenslet of the lenslet array is aligned with a corresponding pinhole of the pinhole array.
- 21.** The system of claim 18, the spectrometer comprising:  
 (a) a lenslet array, to form the multiple channels; (b) optics, to collimate electromagnetic energy of the multiple channels from the lenslet array; and (c) a reflection grating, to disperse the multiple spectral signatures back through optics and to the focal plane array.
- 22.** The system of claim 18, the spectrometer comprising:  
 (a) a lenslet array oriented such that a two dimensional segment of the partitioned field of view images onto a two dimensional portion of the lenslet array; (b) optics, to collimate electromagnetic energy of the multiple channels from the lenslet array; and (c) a reflection grating oriented such that at least one spectrum images back through the optics and onto the focal plane array along a direction of dispersion.
- 23.** A multiwavelength imager, comprising:  
 imaging optics for forming an image of an object;  
 a focal plane array; and  
 at least one micromachined optical element (MMO) located at or near to an image plane of the imager, for providing a spectral signature for use with the focal plane array.
- 24.** The imager of claim 23, the MMO comprising a lenslet array and grating to image the pupil and divide it into wavelengths.
- 25.** The imager of claim 23, further comprising an assembly wheel for positioning multiple MMOs within the imager wherein selection of any one MMO provides differing spectral signatures from any other MMO of the assembly wheel.
- 26.** A hyperspectral imaging system, comprising:  
 imaging optics for forming an image of an object;  
 a focal plane array; and  
 a spectrometer having an array of pinholes that divide a field of view of the imaging optics into multiple channels and dispersive optics for reimaging the multiple channels as multiple spectral signatures onto the focal plane array.
- 27.** A hyperspectral imaging system, comprising:  
 a lenslet array;  
 a focal plane array;  
 a pinhole array between the detector array and the lenslet array, the pinhole array having a different pitch than the lenslet array, the lenslet array moveable to define where an object is viewed by the imaging system, wherein each lenslet of the lenslet array is aligned with a corresponding pinhole of the pinhole array; and  
 a spectrometer for reimaging multiple channels from the lenslet array as multiple spectral signatures onto the detector array.
- 28.** In a hyperspectral imager, the improvement comprising:  
 at least one zoom lens for selecting a variable field of view of the imager; and  
 a variable dispersion element for selecting dispersion for spectral signatures for the imager.
- 29.** A hyperspectral imager of claim 28, wherein the variable dispersion element is a pair of crossed prisms.
- 30.** In a hyperspectral imager of the type that forms a hyperspectral data cube, the improvement comprising:  
 at least one zoom collimating or relay lens that variably adjusts spectral and spatial resolution of the hyperspectral data cube.

\* \* \* \* \*