



US 20050236602A1

(19) **United States**

(12) **Patent Application Publication**  
**Viteri et al.**

(10) **Pub. No.: US 2005/0236602 A1**

(43) **Pub. Date: Oct. 27, 2005**

(54) **WORKING FLUID COMPOSITIONS FOR  
USE IN SEMI-CLOSED BRAYTON CYCLE  
GAS TURBINE POWER SYSTEMS**

(76) Inventors: **Fermin Viteri**, Sacramento, CA (US);  
**Roger E. Anderson**, Gold River, CA  
(US)

Correspondence Address:  
**BRADLEY P. HEISLER**  
**HEISLER & ASSOCIATES**  
**3017 DOUGLAS BOULEVARD, SUITE 300**  
**ROSEVILLE, CA 95661 (US)**

(21) Appl. No.: **11/001,437**

(22) Filed: **Nov. 30, 2004**

**Related U.S. Application Data**

(62) Division of application No. 09/855,224, filed on May 14, 2001, now Pat. No. 6,824,710.

(60) Provisional application No. 60/203,726, filed on May 12, 2000. Provisional application No. 60/207,530, filed on May 26, 2000.

**Publication Classification**

(51) **Int. Cl.<sup>7</sup>** ..... **F02C 3/30**

(52) **U.S. Cl.** ..... **252/372**

(57) **ABSTRACT**

A gas mixture is provided which includes CO<sub>2</sub>, steam and oxygen. The gas mixture has characteristics which mimic those of air, so that an air compressor need not be modified to effectively compress the gas mixture. The gas mixture is compressed within the compressor and routed to a combustor where a fuel combusts with the oxygen of the gas mixture and produces an exhaust which is substantially entirely CO<sub>2</sub> and steam. This exhaust can be routed through a turbine and expanded to drive the compressor and output power. A portion of the exhaust is routed to a return duct where excess steam and CO<sub>2</sub> is discharged and oxygen is added to the exhaust sufficient to convert the exhaust back into the original gas mixture. Combustion based power is thus generated with removal of steam and CO<sub>2</sub> in an easily captured form.

GAS TURBINE COMBINED CYCLE

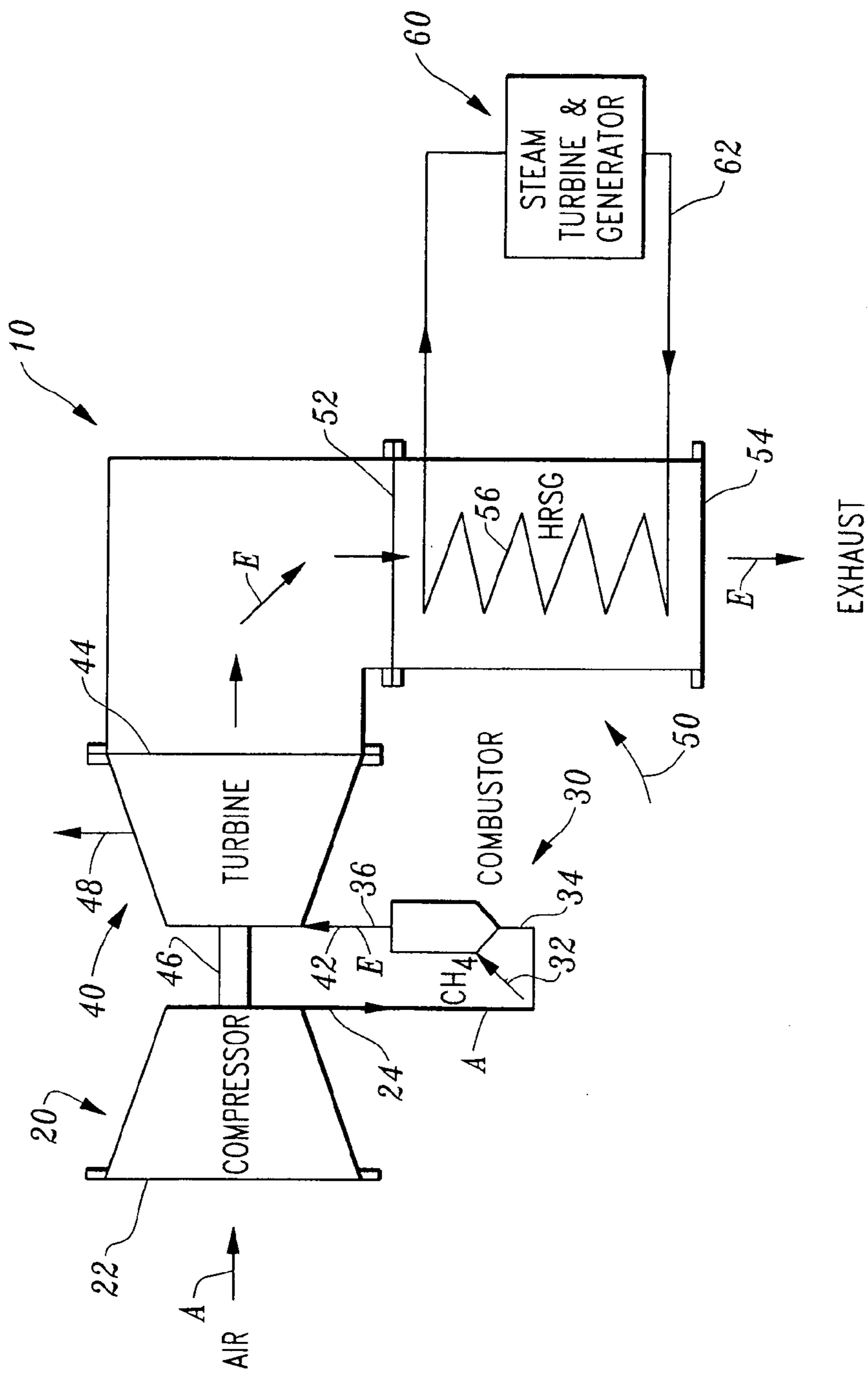

Fig. 1  
(Prior Art)

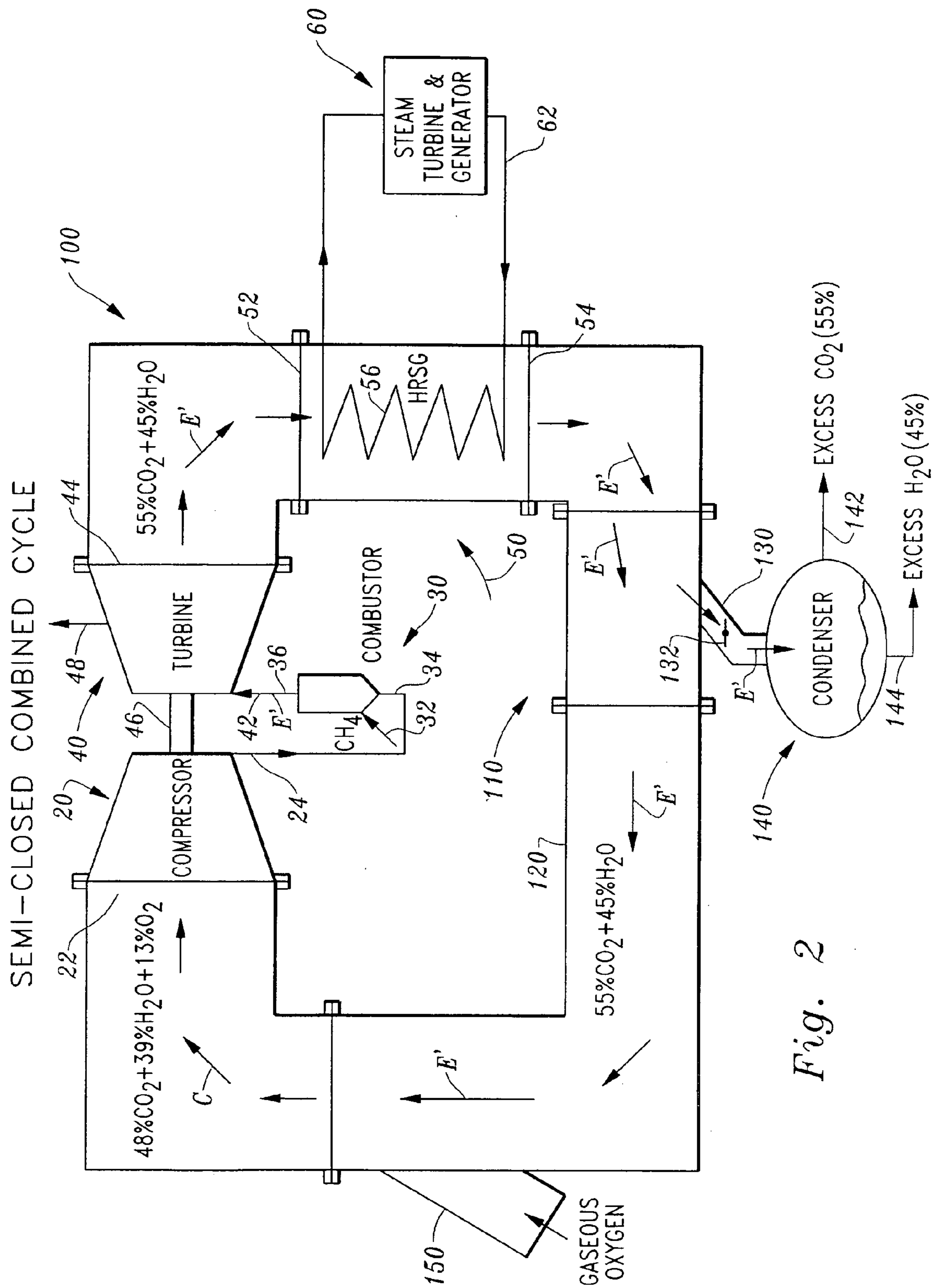

Fig. 2

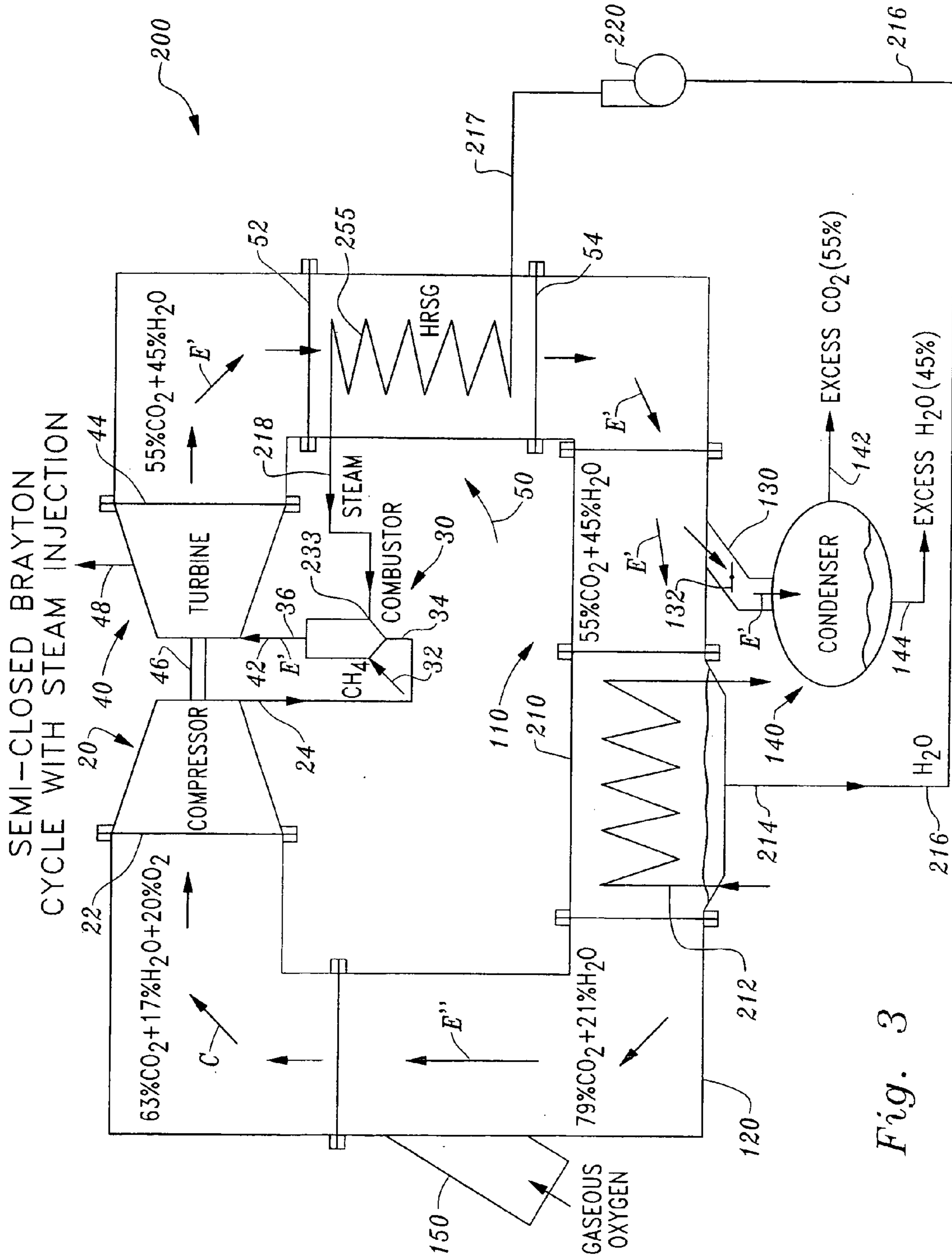

Fig. 3

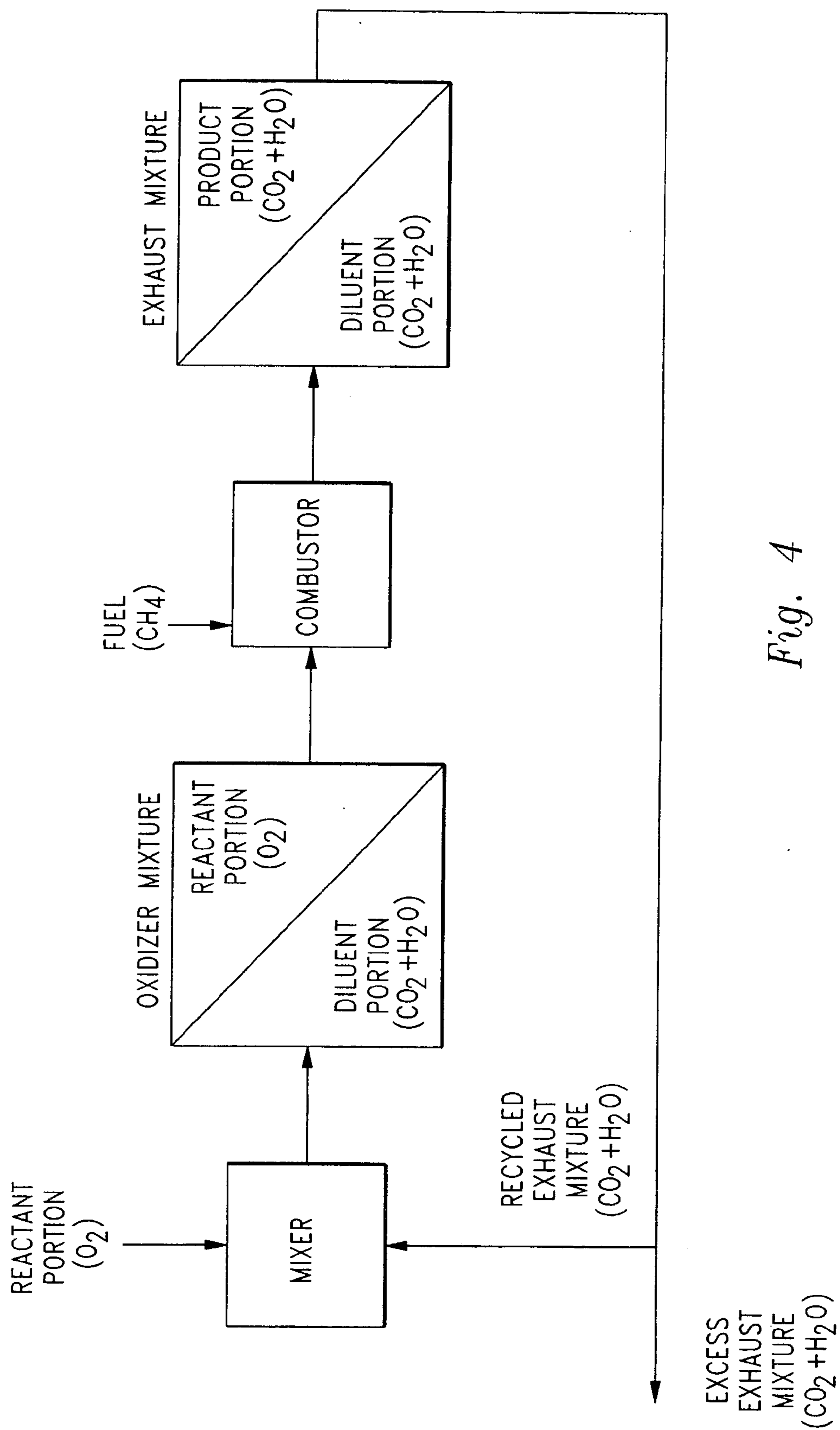

Fig. 4



**WORKING FLUID COMPOSITIONS FOR USE IN  
SEMI-CLOSED BRAYTON CYCLE GAS TURBINE  
POWER SYSTEMS**

**CROSS-REFERENCE TO RELATED  
APPLICATIONS**

[0001] This application is a divisional of U.S. patent application Ser. No. 09/855,224, filed on May 14, 2001 and issued as U.S. Pat. No. 6,824,710 on Nov. 30, 2004. This application claims benefit under Title 35, United States Code § 19(e) of U.S. Provisional Application No. 60/203,726 filed on May 12, 2000 and U.S. Provisional Application No. 60/207,530 filed on May 26, 2000.

**FIELD OF THE INVENTION**

[0002] The following invention relates to gaseous working fluids which are compressed, heated and expanded to generate power. More particularly, this invention relates to working fluids for a semi-closed Brayton cycle power system which includes a gas turbine operating on the working fluid which is partially recirculated, the system eliminating emission of pollutants and emitting carbon dioxide in an easily separated and recoverable form.

**BACKGROUND OF THE INVENTION**

[0003] Gas turbine power systems have become popular systems for meeting modern society's power needs. Not only do gas turbines provide thrust for most large aircraft, but they also have been adapted for use in generation of electricity in stationary power plants.

[0004] Gas turbines operate on the Brayton cycle and have a working fluid, typically air, which remains gaseous throughout the cycle. While the Brayton cycle can theoretically be closed so that the working fluid recirculates, the vast majority of operational gas turbine power plants operate as an open Brayton cycle. In the open Brayton cycle commonly found in commercial stationary power plants, air is drawn into a compressor where its pressure and temperature increase. The temperature of the air is then further increased by combusting a fuel, most often natural gas, in the air to produce a working fluid including air (minus the oxygen which reacts with the fuel) and the products of combustion of the oxygen and the fuel (typically carbon dioxide and steam). This high temperature high pressure working fluid is fed into a turbine where the working fluid is expanded and its temperature and pressure decreased. The turbine drives the compressor and typically additionally drives a generator for the generation of electric power. The working fluid is exhausted from the turbine in a simple open Brayton cycle.

[0005] Most operational stationary gas turbine power systems include a simple open Brayton cycle only as one part of a combined cycle. Specifically, because the working fluid still has a relatively high temperature when exiting the turbine, this heat can be used, such as to generate steam in a heat recovery steam generator before finally being exhausted. The steam heated within the heat recovery steam generator can then be utilized to drive a steam turbine, such as that found in any typical closed Rankine cycle steam power plant. When operated as a combined cycle, the open Brayton cycle gas turbine and closed Rankine steam turbine combine to most efficiently extract power from the fuel combusted within the gas turbine (in some systems over 50% thermal efficiency).

[0006] While significant advances in compressor and turbine designs have greatly increased the efficiency with which the gas turbine operates and have increased the temperature at which the gas turbine can operate, the gas turbine has certain drawbacks. One drawback of the open Brayton cycle gas turbine is that the exhaust includes oxides of nitrogen (NO<sub>x</sub>). NO<sub>x</sub> is a pollutant which can only be emitted in compliance with strict environmental regulations within the United States. Also, open Brayton cycle gas turbines emit carbon dioxide (CO<sub>2</sub>) into the atmosphere. While emission of CO<sub>2</sub> is not currently regulated by the United States government, mounting scientific evidence has connected the emission of CO<sub>2</sub> with global warming and other negative atmospheric effects. Numerous proposals are being evaluated for regulation of the emission of CO<sub>2</sub>. Accordingly, a need exists for a way to eliminate the emission of NO<sub>x</sub>, CO<sub>2</sub> and other pollutants from gas turbines.

[0007] Techniques do exist for reduction of the emission of NO<sub>x</sub> and the elimination of CO<sub>2</sub> from open Brayton cycle gas turbine exhaust. The exhaust can be scrubbed of a significant portion of the NO<sub>x</sub> by various different processes applied to the exhaust to either convert (i.e. using ammonia) or separate the NO<sub>x</sub> from the exhaust. Such "scrubbers" not only decrease the efficiency of the operation of the gas turbine, they are costly and also fail to remove all of the NO<sub>x</sub> from the exhaust.

[0008] Large quantities of CO<sub>2</sub> are produced within the open Brayton cycle gas turbine as one of the major products of combustion of the natural gas in air. This CO<sub>2</sub> is exhausted in gas form mixed with the large amount of nitrogen in the air which passes through the gas turbine. If removal of the CO<sub>2</sub> is desired, the CO<sub>2</sub> must first be separated from the nitrogen and other gaseous constituents of the working fluid (i.e. by chemical and/or physical absorption of the CO<sub>2</sub>, or endothermic stripping processes for separating CO<sub>2</sub> from the exhaust gases). The CO<sub>2</sub> can then be used in industrial processes or can be eliminated, such as by pressurization and sequestration in underground or deep sea locations. While such CO<sub>2</sub> sequestration is a known technique, significant energy is utilized in separating the CO<sub>2</sub> from the nitrogen, and hence the efficiency of the open Brayton cycle gas turbine is significantly decreased when CO<sub>2</sub> separation is required. Accordingly, a need exists for more efficient separation of the CO<sub>2</sub> from other portions of the working fluid so that the efficiency of the gas turbine is not radically diminished.

[0009] Closed Brayton cycle gas turbines have been developed for certain specific applications, such as for gas turbines which operate in nuclear power plants. In the closed Brayton cycle a working fluid is provided (typically Helium in nuclear power plants) which remains separate from the heat source and which is recirculated from the turbine exhaust back to the compressor without ever being exhausted. The compressor typically needs modification when the gas being compressed is changed. Because the working fluid is not exhausted, it is not a source of atmospheric pollution. The heat source which heats the working fluid can be nuclear, solar, geothermal or some other form of renewable non-polluting heat source so that atmospheric emissions are avoided.

[0010] However, if combustion of a hydrocarbon fuel with air is utilized to heat the working fluid between the com-



pressor and the turbine, the closed Brayton cycle gas turbine will still have an exhaust which includes CO<sub>2</sub> and NO<sub>x</sub>. While renewable non-polluting heat sources such as nuclear, solar and geothermal are effective, they suffer from drawbacks which have limited their ability to be fully competitive with hydrocarbon fuel combustion powered gas turbine systems. Other closed Brayton cycle or partially closed Brayton cycle gas turbine power systems have been proposed which utilize a mixture of CO<sub>2</sub> and oxygen as the combustion medium. For instance, see U.S. Pat. No. 5,724,805 to Golomb. While such CO<sub>2</sub> closed Brayton cycle gas turbine systems do keep nitrogen out of the combustor and so do not produce NO<sub>x</sub>, the high density of CO<sub>2</sub> makes it ill suited for use within a compressor which has been designed for compression of air. Accordingly, a need exists for a Brayton cycle gas turbine which heats the working fluid by combustion of a hydrocarbon fuel and which avoids emission of pollutants into the environment.

[0011] Another known technique for modifying prior art open Brayton cycle gas turbines is to inject steam into the combustor upstream of the turbine. When steam is injected into the combustor, the power output and the efficiency of the open Brayton cycle can be enhanced. Various different prior art steam injection open Brayton cycles are disclosed by Wilson and Korakianitis in *The Design of High-Efficiency Turbo Machinery and Gas Turbines*, Second Edition, 1998, Prentice-Hall, Inc. For instance, Wilson and Korakianitis cite one study by the General Electric Corporation that their LM5000 gas turbine, when fitted with steam injection and intercooling will experience a power increase from 34 MW to 110 MW and an efficiency improvement from 37% to 55%, compared to a simple Brayton cycle gas turbine power system with no associated Rankine cycle. Such steam injection open Brayton cycles typically do not operate as part of a combined cycle, but rather utilize the heat recovery steam generator to turn feed water into steam for injection upstream of the turbine. Hence, by steam injection, high efficiencies and high power outputs are provided without requiring a separate steam turbine and condenser as required for a combined cycle.

[0012] Steam injection open Brayton cycles also suffer from numerous drawbacks. Such cycles require feed water purification to keep the machinery in good working order. Water purification costs hence impede the desirability of prior art steam injection open Brayton cycles. Also, prior art steam injection open Brayton cycles still produce NO<sub>x</sub>, carbon dioxide and other pollutants which are emitted into the atmosphere as with the non-steam injection open Brayton cycle gas turbine power systems described above.

[0013] The prevalence of open Brayton cycle gas turbines and particularly combined cycle gas turbine power systems throughout the world which are emitting large amounts of NO<sub>x</sub> and CO<sub>2</sub> into the environment makes desirable the provision of a method and apparatus for retrofitting open Brayton cycle gas turbines in a manner which does not interfere with the existing equipment but which eliminates emission of nitrogen oxides, CO<sub>2</sub> and other pollutants into the atmosphere, so that capital costs associated with such retrofits can be minimized. Such retrofits would additionally benefit from the use of a working fluid which matches the performance characteristics of working fluids in known prior art open Brayton cycle systems so that optimum performance of the system components can be maintained.

## SUMMARY OF THE INVENTION

[0014] The needs for pollutant emission elimination and gas turbine efficiency preservation identified above are met by the semi-closed Brayton cycle gas turbine power system of this invention and the associated working fluids employed by this system. This power system utilizes all of the major components of an open Brayton cycle gas turbine power system and optionally also the major components of a combined cycle power system. Additional equipment is added to recirculate at least a portion of the working fluid exiting the turbine and to cool the exhaust if necessary so that it passes back to the compressor forming a semi-closed Brayton cycle.

[0015] Specifically, the semi-closed Brayton cycle power system of this invention includes a divider coupled to the turbine outlet of an otherwise known prior art open Brayton cycle gas turbine. The divider splits the exhaust flow of the working fluid exiting the turbine output. A portion of the divider leads to a return duct which directs a major portion (approximately 85%) of the turbine exhaust back to the compressor inlet. The other portion of the divider leads to a separation duct which leads to a condenser having a condensate outlet and a gas outlet.

[0016] An oxygen duct directs oxygen into the return duct so that oxygen is added to the portion of the turbine exhaust which passes from the divider into the return duct. The oxygen entering the return duct is mixed with the exhaust therein so that the compressor inlet receives a mixture of the turbine exhaust and the oxygen.

[0017] The compressor gas mixture typically includes three gases which are mixed together. These gases include oxygen, steam (water vapor) and CO<sub>2</sub>. The percentage of the gas mixture which each one of these constituents provides can vary. A preferred simple constitution of the gas mixture can be 13% wt oxygen, 39% wt water and 48% wt CO<sub>2</sub>. These constituent percentages can vary somewhat. Preferably, the constituents which form the compressor gas mixture are present at a ratio which is selected so that the gas mixture mimics the properties of air, which is itself a mixture of gases. At the preferred constituent percentages identified above, the various quantifiable physical properties of air (i.e. gas constant, specific heat, density, etc.) are closely matched. Hence, the compressor compresses the gas mixture in the same manner that it compresses air without operating outside of its design limits.

[0018] The compressed gas mixture enters the combustor where natural gas or pure methane is combusted with the oxygen in the gas mixture. The methane combusts with the oxygen in the gas mixture just as it would with the oxygen in air. If sufficient methane is supplied to consume all of the oxygen in the gas mixture (a stoichiometric mixture ratio), the working fluid exiting the outlet port of the combustor is entirely CO<sub>2</sub> and steam. These gases have two sources, CO<sub>2</sub> and steam from the gas mixture entering the combustor and CO<sub>2</sub> and steam generated as products of combustion of the oxygen and the methane.

[0019] This working fluid passes through the turbine and exits the turbine output as the exhaust. Because the exhaust is entirely CO<sub>2</sub> and steam, no NO<sub>x</sub> is present and no NO<sub>x</sub> elimination equipment need be utilized. If the semi-closed cycle is optionally acting as part of a combined cycle, the



exhaust passes through a heat recovery steam generator where it gives up heat to the steam in the “bottoming” Rankine cycle. The exhaust then exits the heat recovery steam generator and enters the divider. A portion of the exhaust is directed to the return duct where it is directed back to the compressor. This exhaust, when mixed with the oxygen from the oxygen duct returns to the appropriate proportions necessary to constitute the gas mixture described in detail above. The gas mixture then again passes through the semi-closed Brayton cycle as described above.

[0020] A portion of the exhaust entering the divider is diverted into the separation duct. This exhaust enters a condenser. Because the exhaust is entirely CO<sub>2</sub> and water, and because water condenses at a much higher temperature than CO<sub>2</sub>, the condenser can very effectively and efficiently condense the water while the CO<sub>2</sub> remains gaseous. A condensate outlet removes the water portion of the exhaust. The water is pure and can be utilized as desired without contamination of the environment.

[0021] The condenser gas outlet removes CO<sub>2</sub> from the condenser. This CO<sub>2</sub> is essentially pure. Hence, the high energy process of removing CO<sub>2</sub> from nitrogen which would be necessary to separate CO<sub>2</sub> from exhausts of prior art open Brayton cycle gas turbines is avoided. The CO<sub>2</sub> can be sold as an industrial gas, utilized beneficially or can be compressed and sequestered in an underground sequestration site, deep ocean location or any other suitable terrestrial formation.

[0022] Because the compressor gas mixture and other working fluids have properties which mimic those of air the major components of the open Brayton cycle gas turbine can be left unmodified and the remaining portions of the semi-closed Brayton cycle of this invention can be added so that an open Brayton cycle gas turbine power system can be retrofitted and modified into a non-polluting power plant. Such a retrofit can occur both for a simple open Brayton cycle gas turbine power system with addition of an appropriate turbine exhaust cooling heat exchanger and for a combined cycle power system.

[0023] The semi-closed Brayton cycle gas turbine power system of this invention can be adapted to utilize steam injection upstream of the turbine to provide the semi-closed Brayton cycle with the enhanced efficiency and power output benefits of steam injection detailed above. Because the semi-closed power system generates purified water, this generated water source is used and a separate purified water source is not required. Specifically, in the semi-closed cycle with steam injection a partial condenser is located within the return duct which condenses some of the steam out of the exhaust. The water produced by the condensation of some of the steam in the exhaust is routed through the heat recovery steam generator where it is converted back into steam.

[0024] This pure steam is then injected upstream of the turbine. For instance, the steam can be injected with the fuel, injected with the oxidizer from the compressor, or injected separately into the combustor or between the combustor and the turbine. While not preferred, excess water exiting the condenser downstream from the separation duct could similarly be utilized for steam injection.

[0025] When the steam is produced from water extracted from a partial condenser in the return duct, the ratio of steam

to carbon dioxide within the working fluid passing through the return duct is decreased. As a result, the compressor can compress more oxygen and less steam with the same amount of work. With more oxygen passing through the compressor, more fuel can be combusted in the combustor and the power output of the semi-closed cycle is increased. Also, efficiency of the cycle is increased. While steam injection is typically utilized as a replacement for the “bottoming” Rankine cycle of the semi-closed combined cycle, steam injection could be utilized within a semi-closed combined cycle power system with the heat recovery steam generator generating steam for injection into the combustor upstream of the gas turbine and also generating steam for use within the bottoming Rankine cycle.

#### OBJECTS OF THE INVENTION

[0026] Accordingly, a primary object of the present invention is to provide a Brayton cycle gas turbine power system which does not emit NO<sub>x</sub> or other pollutants, and which efficiently collects CO<sub>2</sub> for beneficial use or elimination.

[0027] Another object of the present invention is to provide a Brayton cycle gas turbine power system which recirculates a portion of the turbine exhaust for input into the compressor of the power system.

[0028] Another object of the present invention is to provide a process for modifying an open Brayton cycle gas turbine to function as a semi-closed Brayton cycle gas turbine power system which substantially eliminates emission of pollutants.

[0029] Another object of the present invention is to provide substantially nitrogen free air substitute working fluids which can operate within a Brayton cycle gas turbine without significantly altering the performance of the gas turbine and eliminate pollutant emissions from the gas turbine.

[0030] Another object of the present invention is to provide a power system which can efficiently generate power from the combustion of hydrocarbon fuels without emission of pollutants.

[0031] Another object of the present invention is to provide a semi-closed gas turbine power system with steam injection to enhance the power output and, efficiency of the power system.

[0032] In addition to the above objects, various other objects of this invention will be apparent from a careful reading of this specification including the detailed description contained herein below.

#### BRIEF DESCRIPTION OF THE DRAWING FIGURES

[0033] FIG. 1 is a schematic of a combined cycle gas turbine power system such as that which is in common use for electric power generation.

[0034] FIG. 2 is a schematic of a semi-closed combined cycle gas turbine power system according to this invention.

[0035] FIG. 3 is a schematic of a semi-closed gas turbine power system with steam injection according to this invention.



[0036] FIG. 4 is a schematic showing how the compressor gas mixture and combustion products are created and routed through the semi-closed Brayton power system.

#### DETAILED DESCRIPTION OF THE PREFERRED EMBODIMENT

[0037] Referring to the drawings, wherein like reference numerals represent like parts throughout the various drawing figures, reference numeral **10** is directed to a prior art gas turbine combined cycle power system which can be retrofitted according to this invention to become a semi-closed gas turbine combined cycle power system **100** (FIG. 2).

[0038] While many variations and enhancements to this invention are possible, this invention is illustrated by the following detailed disclosure of a simple conversion of a combined cycle gas turbine power system into the semi-closed combined cycle power system of this invention. This disclosure is believed to be the best mode for such a simple conversion. It is acknowledged that enhancements could be made to increase the complexity and performance characteristics of the invention. Such enhancements are not considered to be part of the best mode for practicing the simple conversion of this invention.

[0039] This disclosure is also provided to enable one skilled in the art to perform the basic conversion of a combined cycle gas turbine power system **10** into the semi-closed combined cycle power system **100** of this invention or to construct the semi-closed combined cycle power system **100** of this invention originally from the separate components making up this system **100**. Also, this disclosure is provided to disclose the best mode for performance this simple conversion of the combined cycle gas turbine power system **10** into the semi-closed combined cycle power system **100** of this invention in its simplest and most easily executable form.

[0040] In essence, and with particular reference to FIG. 2, the semi-closed combined cycle power system **100** preferably includes all of the equipment contained within a prior art open Brayton cycle gas turbine, such as in the power system **10** shown in FIG. 1. The semi-closed power system **100** adds a divider **110** to an exhaust of a turbine **40**. The divider **110** diverts some of the exhaust to a return duct **120** which leads to a compressor **20**. Other portions of the exhaust are diverted to a separation duct **130** which leads to a condenser **140**. An oxygen duct **150** introduces oxygen into the return duct **120** so that the compressor receives a mixture of turbine exhaust and oxygen.

[0041] The compressor compresses this gas mixture and utilizes it within a combustor **30** to combust fuel, such as natural gas or pure methane. The combustor exhaust is then passed through the turbine where it is expanded and does work, both driving the compressor and outputting power from the power system **100**. The exhaust is then directed back to the divider **110** identified above.

[0042] While not necessary, maximum efficiency can be provided by passing the exhaust through a heat recovery steam generator **50** between the turbine **40** and the divider **110**. The heat recovery steam generator **50** transfers heat out of the exhaust **E** and into a steam heating circuit which leads to a separate steam turbine and generator **60** for additional power output from the power system **100**.

[0043] This semi-closed power system **100** completely operates on mixtures of gases including CO<sub>2</sub>, steam and oxygen. Portions of these gases which are diverted by the divider **110** to the separation duct **130** can be exhausted into the atmosphere as none of these gases are currently regulated in the United States with restrictions on their emission as pollutants. However the exhaust, which is primarily CO<sub>2</sub> and water, can easily be separated within a condenser so that pure streams of excess water and excess CO<sub>2</sub> can be provided. These pure streams can then be further handled in a manner other than exhaust into the environment if desired such as to avoid emission of CO<sub>2</sub>, a greenhouse gas.

[0044] More particularly, and with specific reference to FIG. 1, details of the prior art combined cycle gas turbine power system **10** are described which can be retrofitted to form the semi-closed power system **100** of this invention. The combined cycle gas turbine power system **10** is a variation on the open Brayton cycle. Combined cycle gas turbines are in widespread use in the United States and are capable of particularly high power output per unit size and particularly high efficiency. A simplest open Brayton cycle gas turbine power system could also be modified according to this invention by merely eliminating the heat recovery steam generator **50** and steam turbine and generator assembly **60** from the power systems **10**, **100**.

[0045] The combined cycle gas turbine power system **10** begins by induction of air **A** into an inlet **22** of a compressor **20**. The compressor **20** increases a pressure of the air **A**, typically approximately tenfold before the air **A** leaves the compressor **20** through the outlet **24**. The air **A** is then directed to an oxidizer port **34** of a combustor **30**. The combustor **30** additionally includes a fuel port **32**. The fuel port **32** delivers fuel, typically natural gas or pure methane, into the appropriate combustor **30**. With modifications, other hydrocarbon fuels can be used.

[0046] The oxidizer port **34** has air **A** passing therethrough and into the combustor **30** when the combined cycle gas turbine power system **10** is operating according to the prior art. While air can be considered to be an oxidizer, it is in fact the oxygen within the air which acts as the oxidizer. Other constituents of the air, primarily nitrogen, largely do not react within the combustor **30** and merely pass through the turbine **40** as part of the exhaust **E**. However, the combustor **30** typically achieves sufficiently high temperatures during combustion of the fuel that some of the nitrogen does react with the oxygen in the air to form nitrogen oxides, referred to as NO<sub>x</sub>. Hence, the exhaust **E** leaving the combustor **30** through the outlet port **36** not only includes products of combustion of the fuel with the oxygen, namely CO<sub>2</sub> and steam, but additionally includes the nitrogen in the air as well as NO<sub>x</sub> and typically some quantity of volatile organic compounds, referred to as VOCs, and particulates.

[0047] These various constituents of the gas mixture exiting the combustor **30** through the outlet port **36** are together referred to as the exhaust **E**. The exhaust **E** is then directed to the turbine **40** through the input **42**. The exhaust **E** passes through the turbine **40** and exits the turbine **40** through the output **44**. The turbine **40** includes a compressor drive shaft **46** or other mechanical, electrical or other power coupling between the turbine and the compressor **30** which allows a portion of the power generated by the turbine **40**, as the exhaust **E** expands through the turbine **40**, to drive the



compressor **20**. Additional power **40** generated by expansion of the exhaust E through the turbine **40** is outputted from the turbine **40**, typically to an electricity generator along arrow **48**. However, it is known in the prior art for the turbine **40** to be directly coupled to a prime mover or transmission, such as a prime mover on a ship or to an output nozzle on a jet engine, or to otherwise be mechanically or otherwise coupled to other devices for outputting of power other than to an electricity generator.

[0048] The exhaust E can be released into the surrounding atmosphere upon exiting the output **44** of the turbine **40**. In such an arrangement, the gas turbine is functioning as a simple open Brayton cycle gas turbine power system, rather than as a combined cycle gas turbine power system **10**. Preferably, however, in situations where efficiency is to be maximized or where steam production is beneficial for heating or use in processing equipment which requires steam, the exhaust E is directed to a heat recovery steam generator **50**.

[0049] The heat recovery steam generator **50** includes an entrance **52** which receives the exhaust E and an exit **54** where the exhaust E is released into the surrounding environment. The heat recovery steam generator includes a steam heating circuit **56** therein which receives heat which is transferred out of the exhaust E into the steam heating circuit **56**. The steam heating circuit **56** is part of a steam turbine and generator assembly **60** which has a working fluid pathway **62** which passes into the steam heating circuit **56** of the heat recovery steam generator **50** before returning the steam working fluid back to the steam turbine and generator assembly **60**. This assembly **60** would typically include a condenser and pump, as is known in the art to provide a closed Rankine cycle. An alternative to the assembly **60** is to merely provide the steam in the pathway **62** for other heating requirements (i.e. food processing, chemical processing, heating buildings, etc.)

[0050] The steam turbine and generator assembly **60** function as a typical closed Rankine cycle steam power plant except that rather than having a fired boiler for boiling the water to make steam working fluid, the water is passed through the steam heating circuit **56** of the heat recovery steam generator **50** within the combined cycle gas turbine power system **10** to boil the water into steam working fluid before it is directed into the steam turbine of the steam turbine and generator assembly **60** or used for other heating purposes. In essence, the heat recovery steam generator **50** and the steam turbine and generator assembly **60** put to use the excess heat remaining within the exhaust E so that an overall efficiency of the combined cycle gas turbine power system **100** is increased.

[0051] The exhaust E which is directed into the atmosphere has the same constituents that it has upon exiting the combustor **30** through the outlet port **36**. Namely, the exhaust E is a majority nitrogen from the air A which was introduced through the compressor **20** and into the oxidizer port **34** of the combustor **30**. The exhaust E also includes large amounts of CO<sub>2</sub> and steam which were generated within the combustor **30** by the combustion of the methane, natural gas or other hydrocarbon fuel with the oxygen in the air A. The exhaust E would typically additionally include oxygen which was in excess of the amount necessary to combust all of the fuel.

[0052] The nitrogen, any excess oxygen and the steam are exhaust E constituents which are already prevalent in Earth's atmosphere and do not impact the quality of the environment. The CO<sub>2</sub> within the exhaust E is also a constituent of air in Earth's atmosphere, but is present as less than 1% of air. While CO<sub>2</sub> is a constituent of air, within Earth's atmosphere, evidence is mounting that detrimental environmental impacts are associated with increases in the CO<sub>2</sub> present within Earth's atmosphere. For instance, CO<sub>2</sub> is often referred to as a "greenhouse gas" which is believed to contribute to global warming.

[0053] CO<sub>2</sub> is not currently regulated in the United States as a pollutant, but elimination of CO<sub>2</sub> from the exhaust E which is directed back into earth's environment from combined cycle gas turbine power systems **10** is widely considered to be a desirable objective. The remaining constituents of the exhaust are pollutants which in many cases have emission thereof strictly regulated and which detrimentally impact air quality if released or which severely diminish efficiency if collected.

[0054] With particular reference to FIG. 2, the semi-closed combined cycle power system **100** of this invention is described in detail. The semi-closed power system **100** begins with each of the major components of the combined cycle gas turbine power system **10** (FIG. 1) described in detail above. However, the exit **54** of the heat recovery steam generator **50** does not direct the exhaust E' directly into the surrounding atmosphere. Rather, a divider **110** is provided which receives the exhaust E' exiting from the exit **54** of the heat recovery steam generator **50**. The divider **110** has two outlets including a return duct **120** and a separation duct **130**. The return duct **120** directs a major portion (approximately 85%) of the exhaust E' back to the inlet **22** of the compressor **20**. The separation duct **130** directs a remaining portion of the exhaust E passing through the divider **110** to a condenser **140**.

[0055] The divider **110** can have any of a variety of configurations. The primary feature of the divider **110** is that it is capable of splitting the exhaust E' flow into the two separate pathways including the return duct **120** and the separation duct **130**. In a simplest form of the invention, the divider could be unadjustable and merely utilize pressure differentials between the return duct **120** and the separation duct **130** to divide the exhaust E' flow between the return duct **120** and the separation duct **130**.

[0056] Alternatively, a pressure sensitive valve **132** of some sort could be used, such as by placement in the divider separation duct **130**. For instance, if it is desirable for the return duct **120** to have a pressure slightly higher than atmospheric, the valve would be slightly closed to increase the resistance of separation duct **130** and reduce the flow rate. This temporary reduction in the flow rate of separation duct **130** increases the flow rate of return duct **120** and thus increases the recirculating mass of the system and corresponding pressure level. When the proper pressure is achieved, the valve in separation duct **130** is returned to its original position. To reduce the system pressure the reverse of these steps is performed.

[0057] Because the combustor **30** increases an amount of gas in the system, more exhaust E' flows out of the turbine **40** than the amount of gas that flows into the compressor **20**. To keep the pressure within the return duct **120** at the desired



level, such as near or slightly above atmospheric pressure, the separation duct **130** would have the valve **132** within the separation duct **130** open sufficiently so that excess exhaust E' would be diverted through the separation duct **130** and the desired pressure within the return duct **120** would be maintained. Such a valve **132** in the separation duct **130** would control the pressure of the system by increasing or decreasing the flow rate exiting duct **130** until the desired pressure has been reached and steady state conditions are achieved.

[0058] The control valve **132** could also be configured with a vane/damper which might automatically move to divert more or less flow from the return duct **120** and into separation duct **130** merely by pressure monitoring. Also, the vane/damper **130** could be coupled to a drive axle and pressure sensors or other sensors for controlling the semi-closed power system **100** could be utilized to actively control flow rates and pressures within the return duct **120** and the separation duct **130** by controlling the position of the vane/damper **130** within the separation duct **130**.

[0059] The return duct **120** typically is in the form of a substantially airtight conduit. Because the return duct **120** includes exhaust E' therein which includes steam, it would typically need to maintain sufficient temperatures, approximately 180° F. to 200° F. so that the steam making up a portion of the exhaust E' does not condense within the return duct **120**. The return duct **120** can be fitted with insulation to prevent condensation along the walls of the return duct **120**. Additionally, or alternatively, the return duct **120** can be manufactured from materials which can accommodate the condensation of small amounts of water out of the exhaust **120** and merely provide water traps at lowermost portions of the return duct **120** to collect any water condensing within the return duct **120** and direct the water out of the return duct **120**, such as into the condenser **140**.

[0060] The return duct **120** additionally includes an oxygen duct **150** which introduces oxygen into the return duct **120**. The oxygen duct **150** is coupled to a source of gaseous oxygen. Such a gaseous oxygen source could be of a variety of types including air separation units which are capable of removing oxygen from the air, a gaseous oxygen pipeline, a liquid oxygen tank under pressure which bleeds off gaseous oxygen into the oxygen duct **150** or any of a variety of other oxygen supply sources.

[0061] Preferably, the oxygen duct **150** receives oxygen from an air separation unit which is powered by power outputted from the turbine **40**, so that the entire semi-closed combine cycle power system **100** includes the air separation unit therein. The air separation unit can be of a liquefaction type which separates the oxygen from the air by cooling the air to below the condensation point for the nitrogen in the air so that the nitrogen is removed from the oxygen in the air. Such a cryogenic air separation system is described in detail in U.S. Pat. No. 5,611,219 to Bonaquist, incorporated herein by reference. Alternatively, the air separation unit can be configured utilizing ion transfer membrane technology such as that described in detail in U.S. Pat. No. 5,447,555 to Ye, incorporated herein by reference. Other techniques such as vacuum pressure swing adsorption could similarly be utilized, such as that described in detail in U.S. Pat. No. 5,194,890 to McCombs incorporated herein by reference, to separate oxygen out of the air and deliver the oxygen from the oxygen duct **150** into the return duct **120**.

[0062] The oxygen from the oxygen duct **150** is introduced into the exhaust E' within the return duct **120** to form a gas mixture C, called "C-gas" which mimics the characteristics of air. Specifically, the gas mixture C includes the products of combustion of the methane or natural gas with oxygen, namely CO<sub>2</sub> and steam along with the oxygen introduced from the oxygen duct **150**.

[0063] The ratio of the CO<sub>2</sub> with the steam is similar to that which naturally occurs when the methane or natural gas fuel is combusted stoichiometrically with oxygen. Specifically, this ratio of CO<sub>2</sub> to steam when methane is combusted in oxygen stoichiometrically is 55% CO<sub>2</sub> by weight and 45% steam by weight. This ratio of CO<sub>2</sub> to steam is maintained within the exhaust E', through the divider **110**, along either the return duct **120** or the separation duct **130** and into the compressor **20**, where the exhaust E' is combined with the oxygen from the oxygen duct **150** to form the gas mixture C. However, when the oxygen is mixed with the exhaust E' including the CO<sub>2</sub> and the steam, the gas mixture C additionally includes the oxygen. While the ratio of CO<sub>2</sub> to water remains the same, the ratio of CO<sub>2</sub> to the overall gas mixture C and the ratio of the steam to the overall mixture of the gas mixture C are reduced by an amount proportional to the amount of oxygen introduced into the return duct **120** through the oxygen duct **150**. An example of this gas mixture C is provided as follows.

#### EXAMPLE 1

[0064] In this example a minimum amount of oxygen is supplied by the oxygen duct **150** so that the methane fuel burns at a stoichiometric ratio with the oxygen within the gas mixture C and no excess oxygen remains in the exhaust E'. In this hypothetical example, the gas mixture C would be provided with sufficient oxygen so that the gas mixture C would be 13% oxygen by weight.

[0065] Note that air is approximately 23% oxygen by weight and typically reacts with methane with some excess air present which is not necessary for combustion of all of the methane. The gas mixture C has the CO<sub>2</sub> constituents and steam constituents proportionally reduced to provide for the inclusion of the oxygen as 13% wt of the gas mixture C. Specifically, the CO<sub>2</sub> is reduced from 55% wt of the exhaust E' to 48% wt of the gas mixture C. The steam is reduced from 45% wt of the exhaust E' to 39% wt of the gas mixture C.

[0066] Various different formulations for the gas mixture C can be provided, varying from the specific gas mixture C of Example 1, while remaining within the basic concept of the semi-closed combined cycle power system **100** of this invention. Other examples could certainly be utilized.

[0067] A serendipitous and remarkable attribute of the semi-closed combined cycle power system **100** of this invention is that when oxygen is added to the natural products of combustion of methane and oxygen, in an amount sufficient to replace the combusted oxygen, the resulting gas mixture C (having 48% CO<sub>2</sub>, 39% water and 13% oxygen by weight) has attributes which very closely mimic the attributes of air in earth's atmosphere. Hence, not only is the gas mixture C the most simply achievable constituent makeup for the gas mixture C, but this gas mixture C also has air mimicking characteristics which allow it to be directed into the compressor **20** and operate



within the design parameters of the compressor **20** that has been originally designed and constructed for the compression of air **A** (**FIG. 1**) rather than the gas mixture **C**. As a result, the compressor **20** does not require modification to handle the gas mixture **C** rather than air **A** (**FIG. 1**).

[0068] Table 1 provides twelve quantifiable gas parameters which are important to the design of compressors such as the compressor **20**. In this table the values for the parameters of the gas mixture **C**, proposed in the above example, are shown alongside the values for these various parameters for air. A review of this table and a comparison between the gas mixture **C** and air shows that for most parameters the values for air and the values for the various gas mixture **C** are very close. The inlet pressure of the semi-closed cycle **100** can be adjusted, as described above, to better match gas mixture **C** properties with those for air. Also, small compressor speed changes may be desirable. Such speed changes can be done when the compressor design characteristics are known, to fully optimize the cycle **100**.

TABLE 1

Parameter	Gas Mixture <sup>1</sup>	Air
Gas Constant - R, ft <sup>3</sup> /lb <sup>o</sup> F.	56.6	53.3
Specific Heat - Btu/lb <sup>o</sup> F.	0.336	0.250
Specific Heat Ratio ( $\gamma$ )	1.28	1.38
Typical Pressure Ratio	30	30
Inlet Temperature ( $T_1$ ), <sup>o</sup> F.	200	80
Outlet Temperature ( $T_2$ ), <sup>o</sup> F. <sup>(2)</sup>	1058	1065
Inlet Pressure ( $P_1$ ), psia	17.4	14.7
Outlet Pressure, psia	522	441
Inlet Density, lb/ft <sup>3</sup>	0.0671	0.0735
Outlet Density, lb/ft <sup>3</sup>	0.875	0.781
Weight Flow Ratio - (Inlet Cond) <sup>(3)</sup>	1.00	1.00
Speed Ratio ( $N/N_{AIR}$ ) <sup>(4)</sup>	0.99	1.00

<sup>1</sup>Values for the gas mixture **C** including 13% oxygen, 39% steam and 48% CO<sub>2</sub>, by weight calculated by adding known values for each gas constituent multiplied by its percentage of the gas mixture.

<sup>(2)</sup>Compressor efficiency~85%

<sup>(3)</sup> $P_1 * \text{SQRT}(\gamma RT_1) = \text{CONSTANT}$  (where R is the gas constant)

<sup>(4)</sup> $N/\text{SQRT}(\gamma RT_1) = \text{CONSTANT}$

[0069] After the exhaust **E'** exits the output **44** of the turbine **40**, the exhaust **E'** is 55% CO<sub>2</sub> and 45% steam by weight. Some of CO<sub>2</sub> and the steam are produced within the combustor **30** and some enter the combustor **30** through the oxidizer port **34** as part of the gas mixture **C**.

[0070] Preferably, the exhaust **E'** is routed through the heat recovery steam generator **50** so that heat can be removed from the exhaust **E'** to drive a steam turbine and generator assembly **60** so that additional power can be generated from the semi-closed combined cycle power system **100**. However, utilization of the heat recovery steam generator **50** is not strictly required for this power system **100**. Rather, the turbine output **44** could lead directly to the divider **110** so that a semi-closed simple Brayton cycle variation on the power system **100** would be provided.

[0071] When the exhaust **E'** exits the heat recovery steam generator **50** it has a lower enthalpy but maintains its 55% wt CO<sub>2</sub> and 45% wt steam constituent ratio. This exhaust **E'** encounters the divider **110** where a first portion thereof is directed to the return duct **120** for redirection back to the compressor **20**. A second portion of the exhaust **E'** is diverted by the diverter **110** to the separation duct **130**. During steady

state operation, the amount of exhaust **E'** directed to the separation duct **130** is precisely identical to the amount of CO<sub>2</sub> and steam which are generated by the combustion of methane with oxygen within the combustor. In essence, some of the CO<sub>2</sub> and water remain in the semi-closed power system **100** by passing along the return duct **120** and other portions of the exhaust **E'** are removed from the power system **100** so that the amount of working fluid passing through the components making up the power system **100** remains constant.

[0072] Another serendipitous result of the semi-closed power system **100** of this invention is that the exhaust **E'** has a desired constituent makeup which allows it to mimic air merely by having an appropriate amount of oxygen from the oxygen duct **150** added to a portion of the exhaust **E'** within the return duct **120**. Hence, the divider **110** need not discriminate between different constituent gases within the exhaust **E'** when dividing a portion of the exhaust **E'** for passage along the separation duct **130** and out of the system **100**. Rather, it is merely necessary that a homogeneous portion of the exhaust **E'** which matches an amount of the exhaust **E'** which was generated within the combustor as products of combustion of the methane and oxygen (approximately 15%) be diverted into the separation duct **130**. This portion of the exhaust **E'** passing through the separation duct is thus approximately 55% CO<sub>2</sub> and 45% water by weight.

[0073] The separation duct **130** directs this portion of the exhaust **E'** into the condenser **140**. Because steam/water is ordinarily a liquid at standard atmospheric conditions and CO<sub>2</sub> is typically a gas at standard atmospheric conditions, the condenser **140** can effectively and completely separate the steam/water constituent of the exhaust **E'** from the CO<sub>2</sub> constituent of the exhaust **E'**. Specifically, cooling water, cooling air or some other cooling medium is typically provided within the condenser **140** to cool the exhaust **E'** to below the condensation point for the steam/water. The steam/water then condenses into a liquid and can be easily removed from a bottom of the condenser **140** along an excess water condensate outlet **142**. Cooler portions of the condenser **140** which still contain gas lead to a gas outlet **144** which will be primarily CO<sub>2</sub>, with some water vapor remaining therein. Any water vapor in the CO<sub>2</sub> is removed during its processing.

[0074] The excess water can be utilized in a variety of ways or discharged into a surrounding environment. The excess CO<sub>2</sub> exiting the condenser **140** along the gas outlet **144** is a substantially pure stream of CO<sub>2</sub>. While CO<sub>2</sub> can be exhausted into the atmosphere in an unregulated fashion under current regulations, its separation into a substantially pure stream at the gas outlet **144** allows for other uses for the CO<sub>2</sub> rather than exhausting into the atmosphere.

[0075] Specifically, the CO<sub>2</sub> could be sold in the industrial gas market, it could be utilized in processes which benefit from use of CO<sub>2</sub>, or it can be pressurized into a liquid form for storage or disposal. Because relatively large quantities of CO<sub>2</sub> are produced by the combustion of the methane with oxygen, regardless of the beneficial uses provided for the CO<sub>2</sub>, some CO<sub>2</sub> will remain which must be disposed of.

[0076] One known prior art technique is to pressurize the CO<sub>2</sub> sufficiently so that it can be sequestered into underground depleted oil wells or other underground fissures, or



directed into deep ocean locations, or any other appropriate terrestrial formation. Such pressurization only places a minimal efficiency penalty on the semi-closed combined cycle power system **100** because substantially only the CO<sub>2</sub> need be pressurized. In contrast, the prior art combined cycle gas turbine **100** with an exhaust including nitrogen and CO<sub>2</sub> would incur a significant efficiency penalty in separating the nitrogen and other gases from the CO<sub>2</sub> before pressurization of the remaining separated CO<sub>2</sub> for sequestration. In essence, removal of oxygen from the air in an air separation unit coupled to the oxygen duct **150** before combustion of the fuel with the gas mixture C, is more efficient than combusting the fuel in air and later separating the exhaust so that the CO<sub>2</sub> can be appropriately handled. Also, 100% of the CO<sub>2</sub> is removable, rather than the 85% to 90% removable with known prior art systems.

[0077] Typically, some water vapor may remain within the gas outlet **144**. During the process of pressurizing the CO<sub>2</sub> within the gas outlet **144**, an initial stage of pressurization would typically cause remaining portions of steam passing through the gas outlet **144** to be removed from the gas outlet **144**. Additionally, other gases which might remain within the gas outlet **144** can be similarly removed. For instance, any excess oxygen which was not combusted within the combustor **30** can conceivably be captured from the gas outlet **144** during the compression of the CO<sub>2</sub> in that the oxygen would remain gaseous after the CO<sub>2</sub> has been liquefied. The oxygen could then be routed to the oxygen duct **150**. Argon and other trace gases could also be separated from the CO<sub>2</sub>, for recovery and sale as by-products.

[0078] With particular reference to **FIG. 4**, details of the routing and transformation of the working fluid within the semi-closed Brayton cycle of this invention are described. The working fluid of the semi-closed Brayton cycle includes two distinct mixtures at different portions of the cycle. A first oxidizer mixture of the working fluid includes oxygen or some other oxidizer and defines the working fluid of the cycle upstream of the combustor. A second exhaust mixture of the working fluid is located downstream of the combustor and reflects inclusion of the combustion products created within the combustor.

[0079] While the oxidizer mixture and exhaust mixture forms of the working fluid could have a variety of different constituent chemical species, a preferred embodiment of this invention configures the oxidizer mixture and the exhaust mixture of the working fluid for combustion of methane or natural gas (natural gas is largely methane) with oxygen at a near stoichiometric ratio. In such a configuration, the oxidizer mixture constituent chemical species includes gaseous molecular oxygen (O<sub>2</sub>) as the only reactant constituent chemical species and a mixture of carbon dioxide and water vapor as the diluent constituent element species and as the product constituent chemical species. When methane is combusted with oxygen the chemical equation for this reaction is as shown in equation 1.

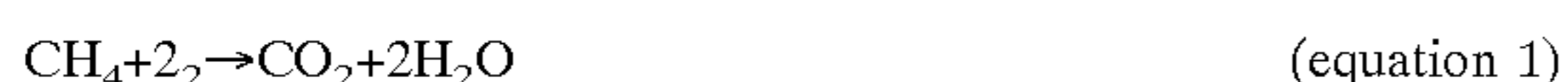

[0080] This combustion reaction is a high energy exothermic reaction, resulting in release of substantial amounts of energy which in turn allow for a large amount of power generation by the semi-closed Brayton cycle power generation system of this invention. In fact, when methane and oxygen are combusted at this stoichiometric ratio (equation

1) the carbon dioxide and steam combustion products typically obtain a temperature of approximately 6,000° F. (depending on the temperature of the reactants and other combustion conditions).

[0081] The challenges associated with handling such high temperature gases without damaging the combustor or the turbine downstream of the combustor are not easily managed. To reduce this combustion products temperature and confine the highest temperature combustion products to as small an area as possible, a non-reacting diluent is included as part of the oxidizer mixture.

[0082] In prior art Brayton cycle power generation systems, such an oxidizer mixture has merely been ambient air. Air has the requisite amount of oxygen to form a reactant portion of the air oxidizer mixture. When the oxidizer mixture is air, the diluent portion is primarily gaseous nitrogen (N<sub>2</sub>) with the nitrogen diluent constituting about eighty percent of the oxidizer mixture. The diluent portion of the oxidizer mixture is not altered in the combustion reaction. Rather, it merely passes through the combustor and helps regulate a temperature of the combustion products.

[0083] In essence, and as shown in **FIG. 4**, the reactant portion (oxygen) of the oxidizer mixture reacts with the fuel (methane) to produce the combustion product portion (carbon dioxide and water) of the exhaust mixture form of the working fluid. The diluent portion (nitrogen) merely passes through the combustor and is heated, forming the diluent portion (nitrogen) of the exhaust mixture form of the working fluid. Unfortunately, some of the nitrogen diluent portion does react with the oxygen at the high temperatures experienced within the combustor, such that nitrogen oxides (NO<sub>x</sub>) are produced. Also, the nitrogen diluent portion of the exhaust mixture is difficult to separate from the carbon dioxide constituent of the product portion (carbon dioxide and water) of the exhaust mixture. Hence, the nitrogen diluent interferes with collection of the carbon dioxide in the exhaust mixture downstream of the combustor.

[0084] This invention uniquely replaces the nitrogen diluent portion in the oxidizer mixture with a diluent portion comprised primarily of carbon dioxide and water. Hence, the oxidizer mixture is formed of the reactant portion (oxygen) and the diluent portion (carbon dioxide and water). As with the prior art Brayton cycle, the reactant portion (oxygen) combusts with the fuel (methane) to form the product portion (carbon dioxide and water) of the exhaust mixture. The diluent portion (carbon dioxide and water) passes through the combustor substantially unaltered and forms the diluent portion (carbon dioxide and water) of the exhaust mixture.

[0085] Additionally, the ratio of carbon dioxide to water in the diluent portion of the oxidizer mixture is selected to match the ratio of carbon dioxide to water in the product portion of the exhaust mixture. Hence, the exhaust mixture includes both a product portion (carbon dioxide and water) and a diluent portion (carbon dioxide and water) which have the same carbon dioxide to water ratios. The exhaust mixture is thus a single homogeneous mixture of carbon dioxide and water having a carbon dioxide to water ratio matching that which naturally occurs when oxygen and methane are combusted together at a stoichiometric ratio.

[0086] The exhaust mixture form of the working fluid is recirculated according to the semi-closed Brayton cycle.



Before this recirculation is complete, a portion of the exhaust mixture is diverted out of the cycle so that a total amount of carbon dioxide and water within the system remains constant even though carbon dioxide and water are continually being produced within the system. The recycled exhaust portion (carbon dioxide and water) passes through a mixer where the reactant portion (oxygen) is added back to the recycled exhaust portion (carbon dioxide and water) to again form the oxidizer mixture form of the working fluid, including the reactant portion (oxygen) and the diluent portion (carbon dioxide and water). This mixer of FIG. 4 is generally depicted in FIGS. 2 and 3 where the oxygen supply duct 150 joins the return duct 120 but could be a specific mixing structure located anywhere between the turbine/expander output and the compressor.

[0087] As specified in detail above, the specific constituent percentages of the chemical species forming the reactant portion and diluent portion of the oxidizer mixture and the product portion and diluent portion of the exhaust mixture can vary to satisfy the particular design criteria for any particular system. The two specific examples identified above and the three gas composition formulations identified in example 2 are merely a few representative samples. One sample overall formulation is shown below as equation 2.

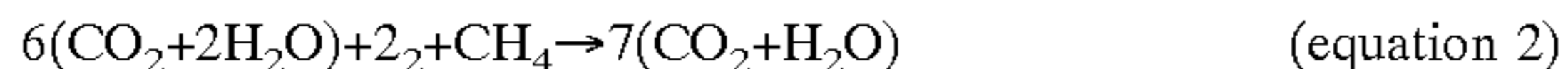

[0088] In equation 2 the diluent portion ( $\text{CO}_2+2\text{H}_2\text{O}$ ) is shown with a prevalence three times that of the reactant portion ( $\text{O}_2$ ). Stated alternatively, seventy-five percent of the oxidizer mixture is diluent and twenty-five percent of the oxidizer mixture is oxygen. A greater or lesser ratio of diluent portion to reactant portion could be provided if desired. If a lesser diluent portion is provided, temperatures of combustion will typically be elevated. Conversely, if a greater amount of diluent is included, lesser temperatures would typically be experienced. Certainly if other hydrocarbon fuels were utilized and combusted with oxygen equations 1 and 2 could be appropriately modified to provide an appropriate balance of constituent chemical species forming the oxidizer mixture and the exhaust mixture forms of the working fluid for the semi-closed Brayton cycle power generation system of this invention.

[0089] The oxidizer mixture can be further modified according to the steam injection variation of the semi-closed Brayton cycle shown in detail in FIG. 3. In such a steam injection variation, some of the water in the exhaust mixture is not routed back to form a portion of the oxidizer mixture, but rather is routed directed to the combustor. In such a steam injection variation, the exhaust mixture would not be modified from that described above. However, the oxidizer mixture would tend to have a greater ratio of  $\text{CO}_2$  to water within the oxidizer mixture after diversion of a portion of the water/steam to the combustor. Where it is desirable to have the oxidizer mixture mimic the characteristics and performance of air, it would be generally desirable to increase a ratio of reactant portion (oxygen) to diluent portion (carbon dioxide and water) to compensate for the lesser amount of water in the oxidizer mixture where the steam injection variation of this invention is utilized.

[0090] In use and operation, and with particular reference to FIGS. 1 and 2, details of the retrofitting of a combined cycle gas turbine power system 10 with components to make it into the semi-closed combined cycle power system 100 of

this invention are described. The semi-closed power system 100 of this invention can of course be constructed originally from separate components as shown in FIG. 2. However, the power system 100 utilizes each of the major components of a combined cycle gas turbine 10 so that retrofitting of the combined cycle gas turbine 10 can be accomplished without replacement or modification of major components.

[0091] Specifically, the divider 110 is coupled to the existing exit 54 of the heat recovery steam generator 50 and configured so that the separation duct 130 and the condenser 140 extend from one portion of the divider 110 and the return duct 120 extends from another portion of the divider 110. The return duct 120 returns back to the inlet 22 of the compressor 20. The oxygen duct 150 is positioned so that it can add oxygen into the return duct 120 and mix the oxygen with the exhaust E' to form the gas mixture C' for use in the semi-closed power system 100. An air separation unit would typically also be provided, which would be coupled to the oxygen duct 150.

[0092] Hence, the combined cycle gas turbine 10 can be retrofitting into a semi-closed combined cycle power system 100 with zero emissions (or vice versa for emergency operation) by merely adding the divider 110 and return duct 120 to route the exhaust E' back to the compressor 20 and the inclusion of a relatively straightforward separation duct 130, condenser 140 and air separation unit for oxygen production. This ability to operate as a semi-closed cycle or an open cycle, in an emergency, provides the plant with a very high reliability factor against unscheduled shutdowns.

[0093] With particular reference to FIG. 3, the semi-closed Brayton cycle power system with steam injection 200 of this invention is described in detail. The steam injection power system 200 begins with each of the major components of the semi-closed power system 100 (FIG. 2) described in detail above. However, for the steam injection power system 200, the semi-closed power system 100 is modified somewhat. Specifically, the heat recovery steam generator 50 is preferably not utilized to generate steam for a steam turbine and generator assembly 60, but rather is utilized to generator steam for injection into the combustor 30. Hence, the steam heating circuit 56, steam turbine and generator assembly 60 and working fluid pathway 62 are removed from the semi-closed power system 100 (FIG. 2) when the system 100 is modified to operate as the steam injection power system 200 (FIG. 3).

[0094] Additionally, the return duct 120 is modified to include a partial condenser 210 therein. The partial condenser 210 is preferably interposed within the return duct 120 so that all of the exhaust E' passes into the partial condenser 210. The partial condenser 210 includes a cooling fluid circuit 212 which passes through the partial condenser 210 in a heat exchange relationship so that a portion of the steam within the exhaust E' is caused to condense within the partial condenser 210. The cooling fluid within the cooling fluid circuit 212 could be any appropriate fluid, but would typically be water or possibly air.

[0095] Lower surfaces of the partial condenser 210 include a condensate outlet 214. The condensate outlet 214 leads to a water return line 216. This water return line 216 is routed back toward the heat recovery steam generator 50. The water within the water return line 216 is pumped up to combustor inlet pressure with a pump 220.



[0096] A high pressure water line 217 exits the pump 220 and passes through the heat recovery steam generator as the steam generation circuit 255. This steam generation circuit 255 outputs steam along steam injection line 218. This steam is then injected into the combustor 30 at the steam injection port 233.

[0097] The steam can in fact be introduced at a variety of locations upstream from the turbine 40 or within the turbine 40. For instance, the steam can be mixed with the compressed gas mixture exiting the compressor 20 before this gas mixture enters the combustor 30 at the oxidizer port 34. The steam could also, or alternatively, be mixed with fuel entering the combustor 30 at the fuel port 32. It is also possible that the steam could enter the combustor 30 within a combustion chamber area where maximum temperatures are achieved and cooling associated with the steam injection would preserve hardware within the combustor 30. The steam can alternatively be introduced downstream from the combustor 30 or at an intermediate stage within the turbine 40.

[0098] While the partial condenser 210 is preferably within the return duct 120, it is also conceivable that the return duct 120 would be split into two pathways with one of the pathways having all or part of the steam condensed therefrom and another of the pathways having no steam condensed therefrom. These two pathways would then be rejoined together with the same amount of water condensed from the exhaust E' as in the preferred embodiment identified above.

[0099] The steam injection power system 200 alters the make-up of the exhaust E' due to the partial condensation of steam within the exhaust E' while it flows through the return duct 120. Specifically, the exhaust E' enters the partial condenser 210 preferably made up of 55% wt CO<sub>2</sub> and 45% wt steam. A CO<sub>2</sub>-enriched exhaust E" exits the partial condenser 210 within the return duct 120. The amount of steam depletion from the exhaust E" depends on an amount of condensation occurring within the partial condenser 210. The CO<sub>2</sub>-enriched exhaust E" then reaches the oxygen duct 150 where oxygen is added to the CO<sub>2</sub>-enriched exhaust E". A gas mixture C' results which has a greater amount of CO<sub>2</sub> and oxygen and a lesser amount of steam when compared to the gas mixture C of the previous embodiment (FIG. 2). An example of this gas mixture C', which is the preferred mixture for the steam injection power system 200, among numerous possible mixtures, is provided in example 2 which follows.

#### EXAMPLE 2

[0100] In this example, a little over half of the steam is condensed within the partial condenser 210. Specifically, the CO<sub>2</sub>-enriched exhaust E" exiting the partial condenser 210 includes 79% wt CO<sub>2</sub> and 21% wt steam. Oxygen is supplied by the oxygen duct 150 at a ratio to the CO<sub>2</sub>-enriched exhaust E" to produce the gas mixture C' including 63% wt CO<sub>2</sub>, 17% wt steam and 20% wt oxygen. This gas mixture C' has air mimicking attributes similar to those of the gas mixture C of the previous embodiment (FIG. 2). Hence, the compressor 20 can compress the gas mixture C' while operating within its design parameters for the compression of air A (FIG. 1).

[0101] Note that the gas mixture C' includes 20% wt oxygen which is approximately the amount of oxygen within

air A. This gas mixture C' can be utilized as the oxidizer within the combustor with an amount of fuel similar to that utilized when the combustor 30 is burning the fuel, such as natural gas or methane, in air A (FIG. 1). In such a scenario, excess oxygen is typically present after full combustion of the fuel. This excess oxygen within the working fluid exiting the combustor 30 would pass through the turbine 40 and be expanded along with other constituents of the exhaust E'.

[0102] The excess oxygen would then travel along with the exhaust through the divider 110 where a portion of the excess oxygen would pass through the separation duct 130 and into the condenser 140. Such excess oxygen would exit the condenser 140 through the gas outlet 142. The excess oxygen could then be readily separated from the CO<sub>2</sub> and returned to the oxygen duct 150 for reuse. The remaining oxygen within the exhaust E' would pass through the divider 110 and on to the return duct 120. It would then pass through the partial condenser 210 and be routed back to the compressor 30. Hence, in such an excess oxygen operation embodiment, a significant amount of oxygen would remain within the exhaust E' (i.e. the exhaust E' could have up to 10% wt oxygen) and CO<sub>2</sub>-enriched exhaust E" such that less oxygen would need to be supplied from the oxygen duct 150 to create the gas mixture C' at the desired 63% wt CO<sub>2</sub>, 17% wt steam and 20% wt oxygen constituency.

[0103] Preferably however, when the gas mixture C' is provided with oxygen as 20% of the gas mixture C', a proportionately larger amount of fuel, such as natural gas, is utilized within the combustor 30 so that a stoichiometric or near stoichiometric ratio is still maintained between the oxygen in the gas mixture C' and the fuel. When such a stoichiometric ratio is maintained, no oxygen remains within the exhaust E'. A greater amount of products of combustion would be provided per unit of gas mixture C' than with the gas mixture C (FIG. 2).

[0104] This greater amount of combustion products would have its temperature controlled by the injection of the steam into the combustor 30 through the steam injection port 233. Hence, temperatures would not exceed the design parameters for the combustor 30 and the turbine 40. Significantly larger amounts of exhaust E' exit the combustor and pass through the turbine 40 per unit of gas mixture C', such that the turbine 40 outputs more power through power output 48. Because additional fuel is also utilized to burn with the additional amount of oxygen within the gas mixture C', the overall efficiency of the steam injection power system 200, when compared to the semi-closed combined cycle power system 100 is only slightly increased, while the power output from the steam injection power system 200 is significantly increased.

[0105] While two steam injection embodiments have been disclosed which utilize the 20% oxygen gas mixture C', including an excess oxygen embodiment and a stoichiometric embodiment, it is understood that numerous different embodiments of the steam injection power system 200 could be utilized having varying degrees of excess oxygen ranging from the excess oxygen present when air is utilized in a typical prior art gas turbine combustor 30 to the stoichiometric embodiment disclosed hereinabove. Each of these embodiments would include 20% oxygen within the gas mixture C'.

[0106] It is also conceivable that the gas mixture C' could be further modified by condensing a greater or lesser amount



of the exhaust E' and/or by adding more oxygen to the exhaust E". Hence, gas mixtures other than the gas mixture C' can result once the oxygen has been added to the CO<sub>2</sub> enriched exhaust E".

[0107] Table 2 provides a comparison of the twelve quantifiable gas parameters utilized in Table 1 above. In Table 2 characteristics of air are compared to three different gas mixtures including the gas mixture C (FIG. 2), the gas mixture C' (FIG. 3) and an intermediate gas mixture with gas constituencies within this intermediate gas mixture being approximately an average between the gas mixture C and the gas mixture C'. This intermediate gas mixture illustrates how numerous different gas mixtures can be formulated which vary between the specific gas mixtures C and C' disclosed in detail above, while still mimicking closely the characteristics of air. This intermediate gas mixture is considered to be particularly desirable for use in compressors which are sensitive to small changes in gas characteristics, in that the intermediate gas mixture more closely mimics the characteristics of air.

TABLE 2

Parameter	Gas Mixture <sup>1</sup>	Gas Mixture <sup>2</sup>	Gas Mixture <sup>3</sup>	Air
Gas Constant - R, ft <sup>3</sup> /lb <sup>o</sup> F.	56.6	51.5	45.7	53.3
Specific Heat - Btu/lb <sup>o</sup> F.	0.336	0.309	0.279	0.250
Specific Heat Ratio ( $\gamma$ )	1.28	1.27	1.27	1.38
Typical Pressure Ratio	30	30	30	30
Inlet Temperature (T1), ° F.	200	180	160	80
Outlet Temperature (T2), ° F. <sup>(4)</sup>	1058	979	934	1065
Inlet Pressure (P1), psia	17.4	16.1	14.9	14.7
Outlet Pressure, psia	522	483	447	441
Inlet Density, lb/ft <sup>3</sup>	0.0671	0.0703	0.0757	0.0735
Outlet Density, lb/ft <sup>3</sup>	0.875	0.939	1.010	0.781
Weight Flow Ratio - (Inlet Cond) <sup>(5)</sup>	1.00	1.00	1.00	1.00
Speed Ratio, N/N <sub>AIR</sub> <sup>(6)</sup>	0.99	0.916	0.849	1.00

<sup>1</sup>Values for the gas mixture C from example 1 above including 13% oxygen, 39% steam and 48% CO<sub>2</sub>, calculated by adding known values for each gas constituent multiplied by its percentage of the gas mixture.

<sup>2</sup>Intermediate gas mixture including 16% oxygen, 28% steam and 56% carbon dioxide.

<sup>3</sup>Gas mixture C' from example 2 above, including 20% oxygen, 17% steam and 63% carbon dioxide.

<sup>(4)</sup>Compressor efficiency~85%.

<sup>(5)</sup> $P_1 * \text{SQRT}(\gamma RT_1) = \text{CONSTANT}$  (where R is the gas constant)

<sup>(6)</sup> $N/\text{SQRT}(\gamma RT_1) = \text{CONSTANT}$

[0108] Specifically, the exhaust mixture of the turbine, assuming no excess oxygen would typically have between about fifty percent and sixty percent CO<sub>2</sub> by weight and between forty percent and fifty percent H<sub>2</sub>O by weight. Most preferably, the exhaust mixture would be about fifty-five percent CO<sub>2</sub> and about forty-five percent H<sub>2</sub>O. If the system operates with excess oxygen, these percentages would proportionately decrease.

[0109] The oxidizer mixture could be varied widely to accommodate direct steam injection (hence reducing a water vapor portion of the oxidizer mixture) and to provide excess oxygen or to provide better matching of air characteristics for optimal compressor performance. Overall by weight, the carbon dioxide could vary from about thirty percent or forty percent to seventy percent or eighty percent. The water vapor could vary from about ten percent or twenty percent

to about forty-five percent or fifty percent. The oxygen could vary from about ten percent or fifteen percent to twenty-five percent or thirty percent. Narrower constituent ranges of about five percent or ten percent surrounding the optimal formulations cited as examples would tend to provide air mimicking characteristics and performance closer to the optimal formulations.

[0110] In use and operation, and with particular reference to FIGS. 1-3, details of the retrofitting of a combined cycle gas turbine power system 10 with components to make it into the semi-closed steam injection power system 200 of this invention are described. The semi-closed steam injection power system 200 of this invention can of course be constructed originally from separate components as shown in FIG. 3. However, the steam injection power system 200 utilizes each of the major components of a combined cycle gas turbine 10 (other than the steam turbine and generator assembly 60), so that retrofitting of the combined cycle gas turbine 10 can be accomplished in a straightforward manner.

[0111] Specifically, the divider 110 is coupled to the existing exit 54 of the heat recovery steam generator 50 and configured so that the separation duct 130 and the condenser 140 extend from one portion of the divider 110 and the return duct 120 extends from another portion of the divider 110. The return duct 120 includes a partial condenser 210 therein. The partial condenser 210 receives cooling fluid and causes a portion of the steam passing through the return duct 120 to be condensed into water which exits the partial condenser 210 along the condensate outlet 214 and water return line 216.

[0112] A pump 220 is provided so that the water can be pumped through the heat recovery steam generator 50. The steam turbine and generator assembly 60 of the combined cycle gas turbine power system 10 are removed and the steam heating circuit 56 within the heat recovery steam generator 50 is now utilized to generate steam with the water from the pump 220 and the partial condenser 210. Steam is delivered from the steam generation circuit 255 within the heat recovery steam generator 50 and directed to the steam injection port 233 of the combustor 30. Hence, the combustor 30 is modified appropriately to include this steam injection port 233. The return duct 120 returns the CO<sub>2</sub>-enriched exhaust E" back to the inlet 22 of the compressor 20. The oxygen duct 150 adds oxygen into the return duct 120 to mix with the exhaust E" to form the gas mixture C'. An air separation unit would typically also be provided, which would be coupled to the oxygen duct 150.

[0113] If the combined cycle gas turbine power system 10 is already configured to be a steam injection power system, the combustor 30 will already include the appropriate steam injection port 233. In such a configuration, removal of the steam turbine and generator assembly 60 would not be required. Rather, the water return line 216 from the partial condenser 210 would merely be coupled to the feed water inlet of the combined cycle gas turbine power system 10. Hence, either a steam injection open Brayton cycle gas turbine or the combined cycle gas turbine 10 can be retrofitted into a semi-closed steam injection power system 200 with zero emissions.

[0114] This disclosure is provided to reveal a preferred embodiment of the invention and a best mode for practicing the invention. Having thus described the invention in this



way, it should be apparent that various different modifications can be made to the preferred embodiment without departing from the scope and spirit of this disclosure. When structures are identified as a means to perform a function, the identification is intended to include all structures which can perform the function specified. No claim language other than that explicitly accompanied by the word "means" should be construed as intending to invoke interpretation of that language as "means plus function" language according to section 112 of Title 35 of the United States code.

What is claimed is:

**1-** A gas mixture for use as an oxidizer mixture portion of a working fluid in a gas turbine combustor, the mixture comprising in combination:

by weight between about forty percent and about eighty percent carbon dioxide, between about ten percent and about fifty percent water and between about ten percent and about thirty percent oxygen.

**2-** The mixture of claim 1 wherein said mixture includes by weight between about forty percent and about fifty-five percent carbon dioxide, between about thirty percent and about fifty percent water and between about ten percent and about twenty percent oxygen.

**3-** The mixture of claim 2 wherein said mixture includes by weight about forty-eight percent carbon dioxide, about thirty-nine percent water and about thirteen percent oxygen.

**4-** The mixture of claim 1 wherein said mixture includes by weight between about fifty percent and about sixty-two percent carbon dioxide, between about twenty percent and about thirty-five percent water and between about ten percent and twenty-five percent oxygen.

**5-** The mixture of claim 4 wherein said mixture includes by weight about fifty-six percent carbon dioxide, about twenty-eight percent water and about sixteen percent oxygen.

**6-** The mixture of claim 1 wherein said mixture includes by weight between about fifty percent and about eighty

percent carbon dioxide, between about ten percent and thirty percent water and between about fifteen percent and about thirty percent oxygen.

**7-** The mixture of claim 6 wherein said mixture includes by weight about sixty-three percent carbon dioxide, about seventeen percent water and about twenty percent oxygen.

**8-** A gas mixture for use as an oxidizer in a combustor of an at least partially closed cycle power generation system, the gas mixture comprising in combination:

molecular gaseous oxygen ( $O_2$ );

gaseous carbon dioxide ( $CO_2$ );

water vapor ( $H_2O$ ); and

wherein a ratio of carbon dioxide to water within said gas mixture matches a ratio of carbon dioxide to water which occurs when methane ( $CH_4$ ) combusts with gaseous molecular oxygen ( $O_2$ ) substantially stoichiometrically.

**9-** The mixture of claim 8 wherein said mixture includes sufficient oxygen to cause said gas mixture to be compressible in a compressor designed to compress air without requiring compressor modification.

**10-** The mixture of claim 8 wherein said mixture includes by weight between about forty percent and about eighty percent carbon dioxide, between about ten percent and about fifty percent water vapor and between about ten percent and about thirty percent oxygen.

**11-** The mixture of claim 8 wherein said ratio of carbon dioxide to water is approximately one carbon dioxide molecule for every two water vapor molecules and about fifty-five percent of a combined weight of the carbon dioxide and the water is carbon dioxide and about forty-five percent of the combined weight of the carbon dioxide and the water is water.

\* \* \* \* \*