

US 20050200608A1

(19) **United States**

(12) **Patent Application Publication**

Ulla et al.

(10) **Pub. No.: US 2005/0200608 A1**

(43) **Pub. Date: Sep. 15, 2005**

(54) **HINGED MOUNT COMBINED MODULAR KEYBOARD AND TABLET PC PROTECTIVE COVER**

**Related U.S. Application Data**

(63) Continuation-in-part of application No. 10/423,284, filed on Apr. 25, 2003, now Pat. No. 6,882,524.

(75) Inventors: **Imran Ulla**, Austin, TX (US); **Mark Rylander**, Austin, TX (US); **Jefferson Blake West**, Austin, TX (US)

**Publication Classification**

(51) **Int. Cl.<sup>7</sup>** ..... **G09G 5/00**  
(52) **U.S. Cl.** ..... **345/168**

Correspondence Address:  
**FORTKORT GREYER + KELTON LLP**  
**8911 N. CAPITAL OF TEXAS HWY.**  
**SUITE 3200**  
**AUSTIN, TX 78759 (US)**

(57) **ABSTRACT**

A modular keyboard (100) for a tablet personal computer (200) provides a cover for covering the display screen of the tablet computer (200). A key array (102) for key-based data entry into the tablet computer (200) which mounts integrally to the cover (100) via a hinge mount (120) which supports the tablet computer (200) in a raised position relative to the key array (102) and presents the tablet computer display for monitoring data entry from the key array (102). The hinge mount (120) is retractable to a recess 128 for using the modular cover (100) as a protective cover.

(73) Assignee: **Motion Computing, Inc.**

(21) Appl. No.: **11/074,807**

(22) Filed: **Mar. 8, 2005**

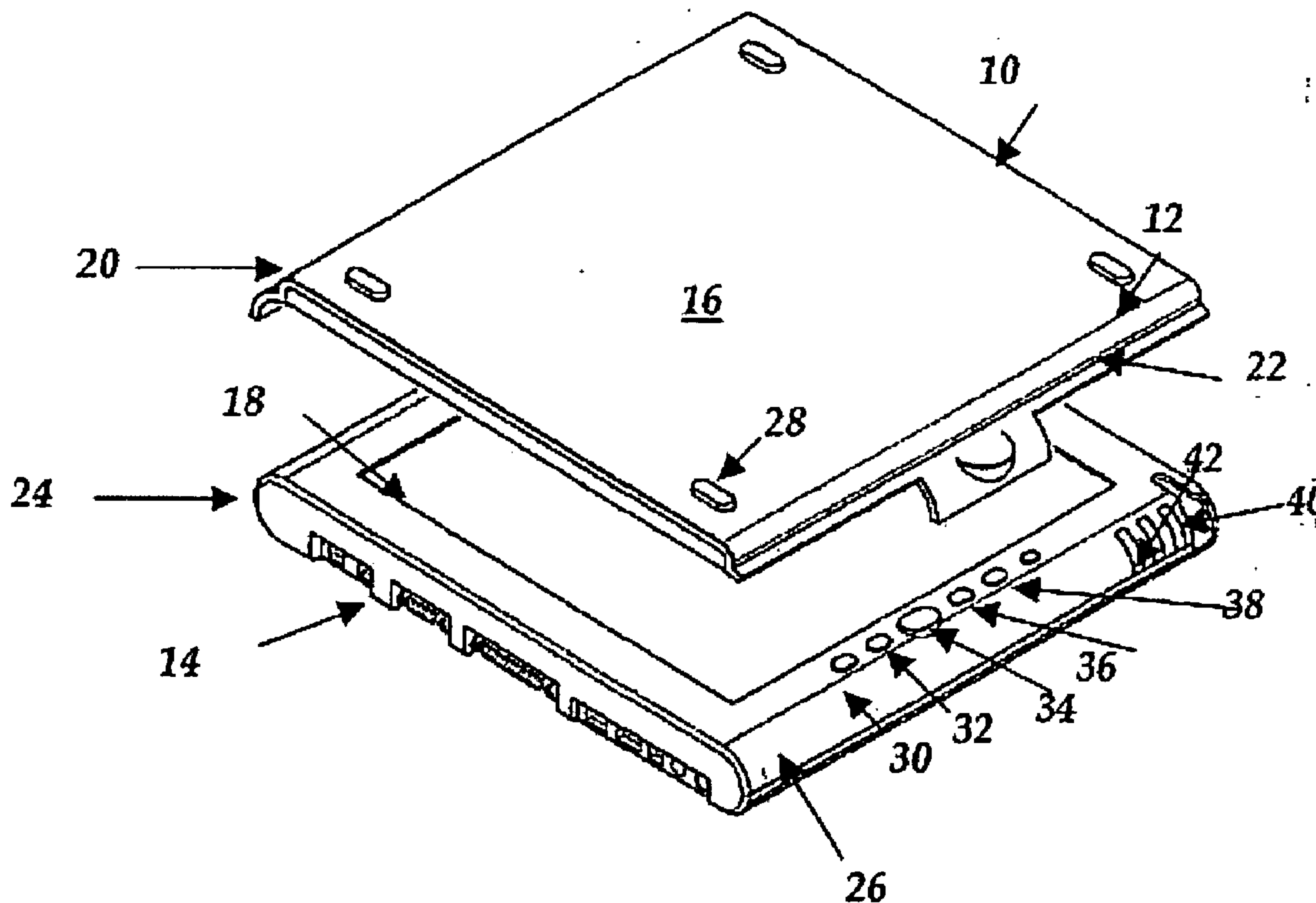

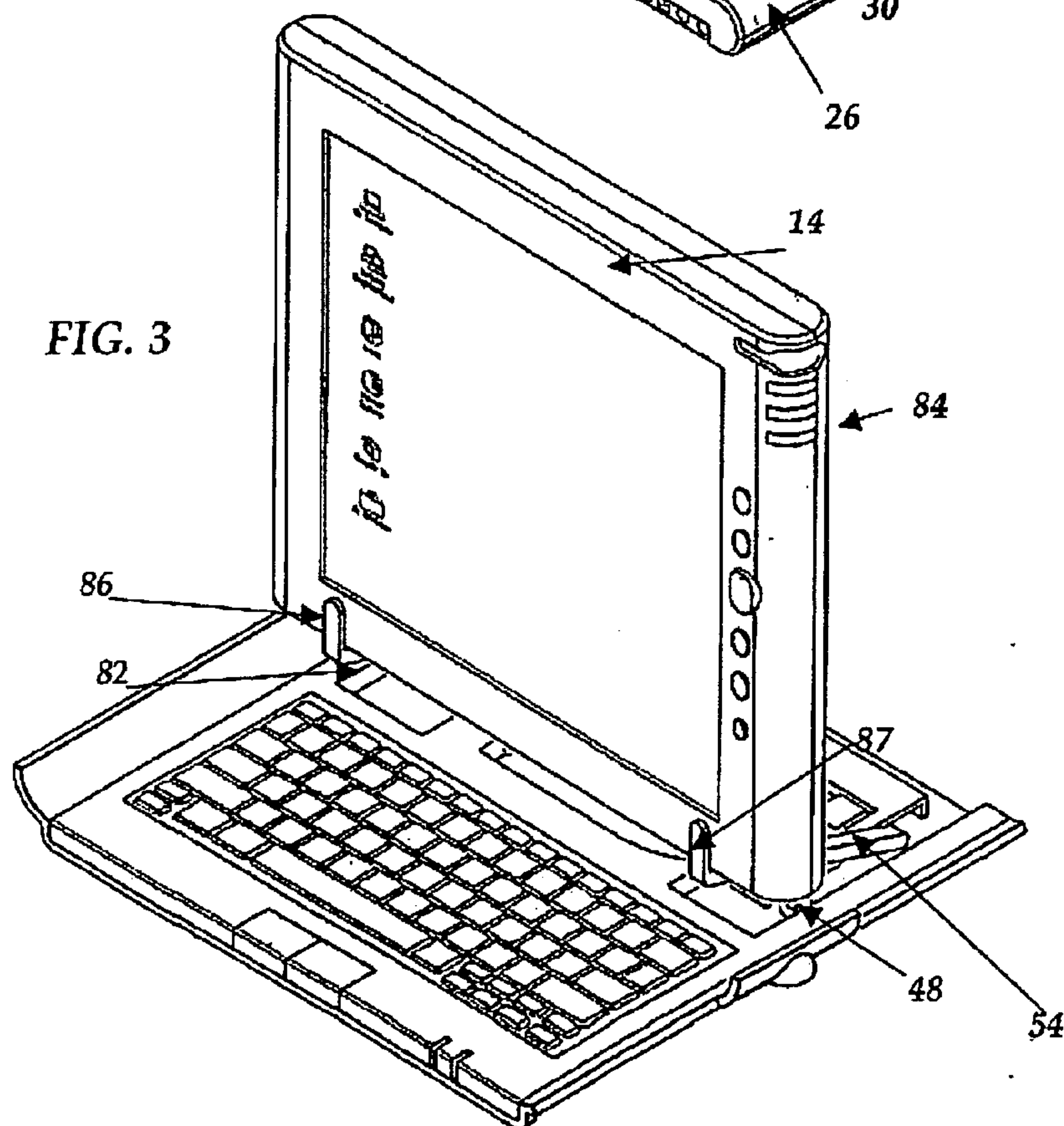
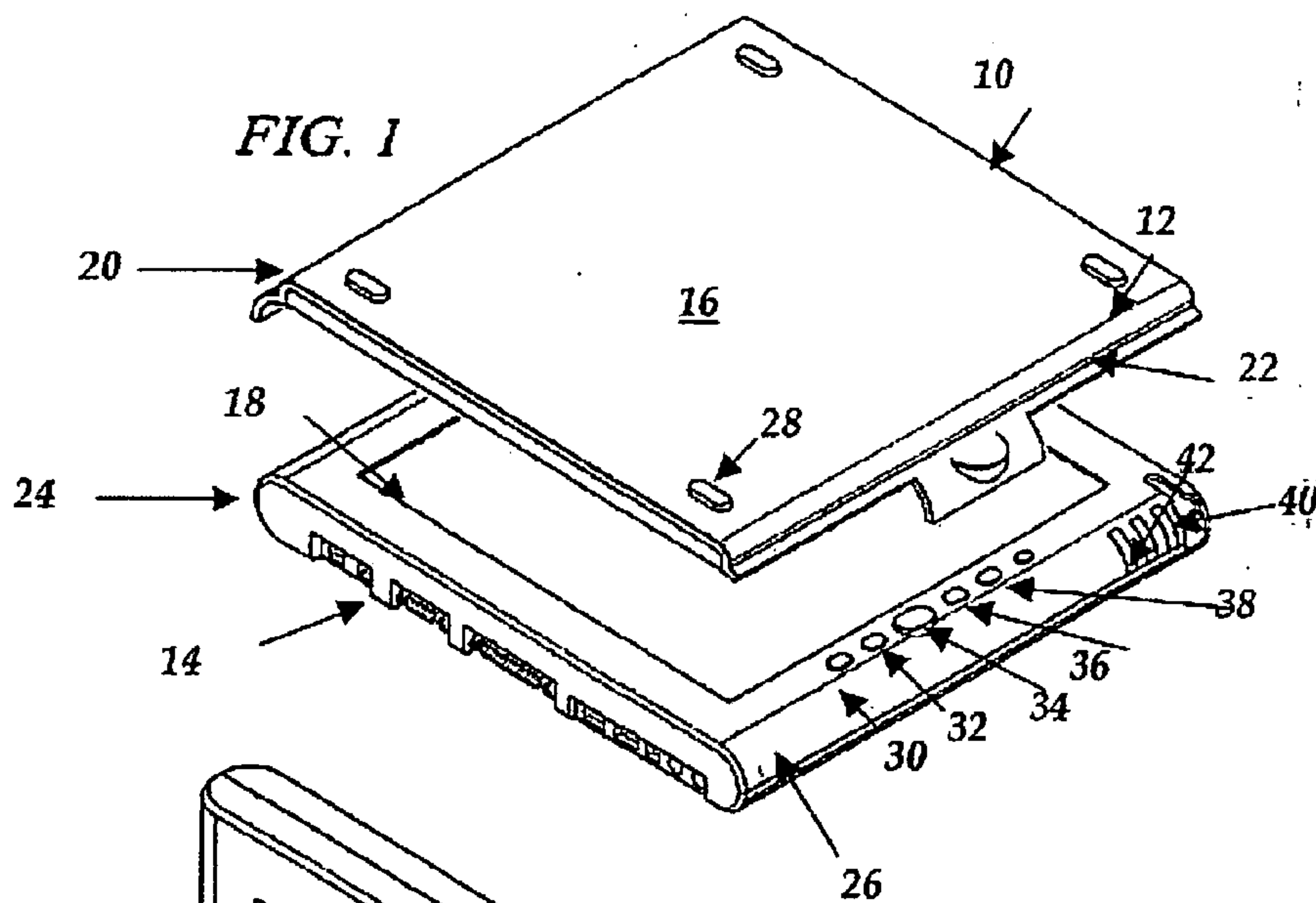

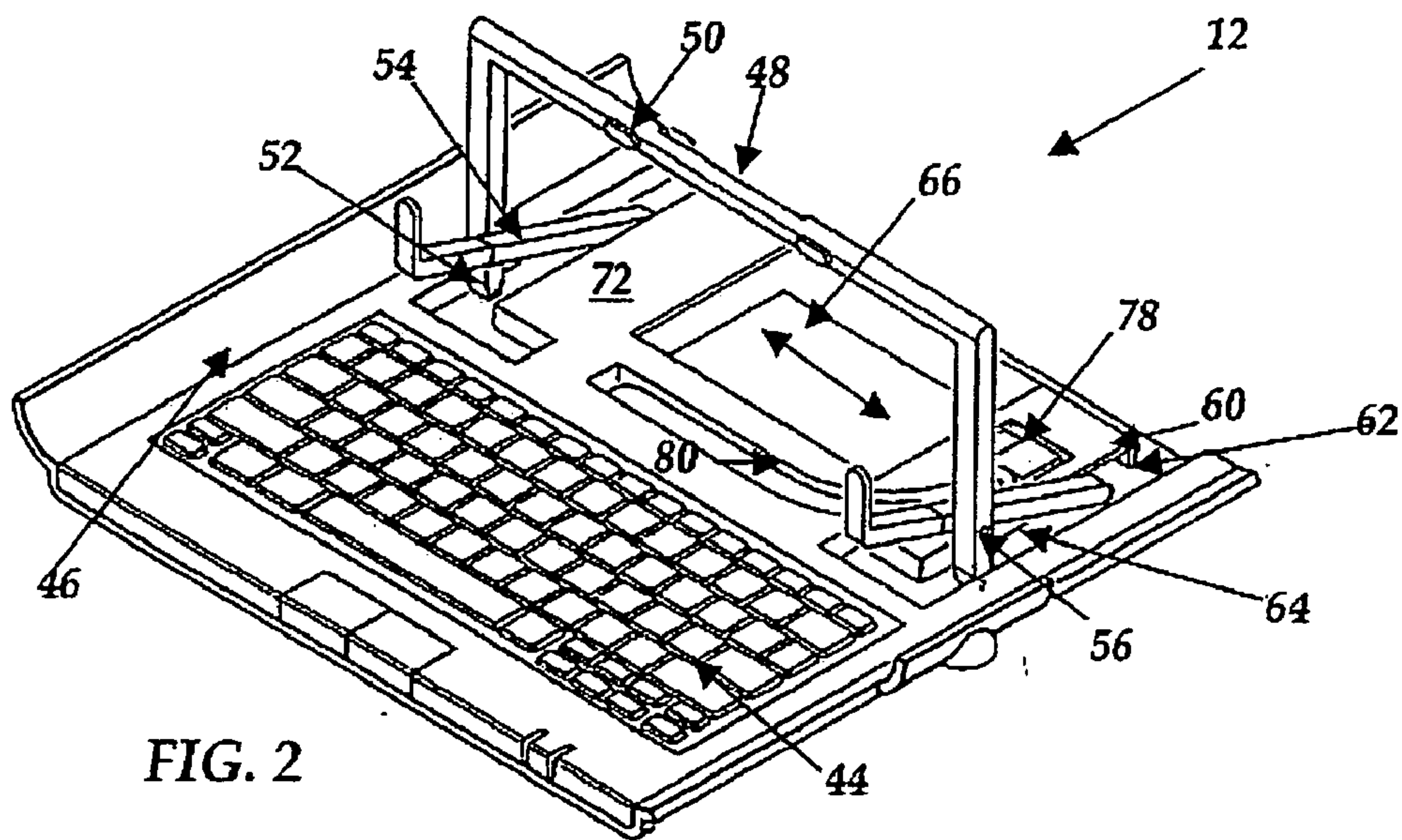

FIG. 2

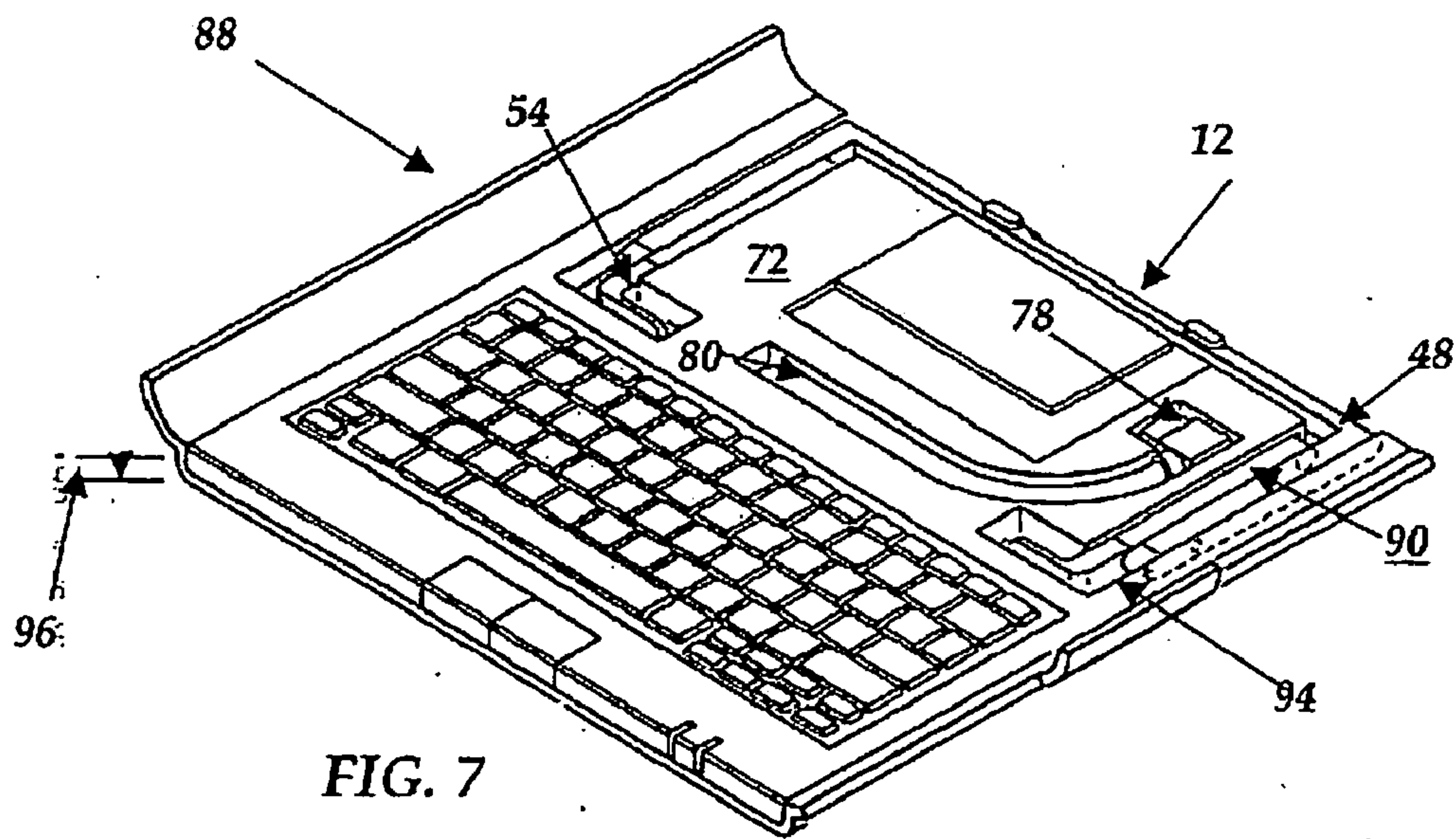
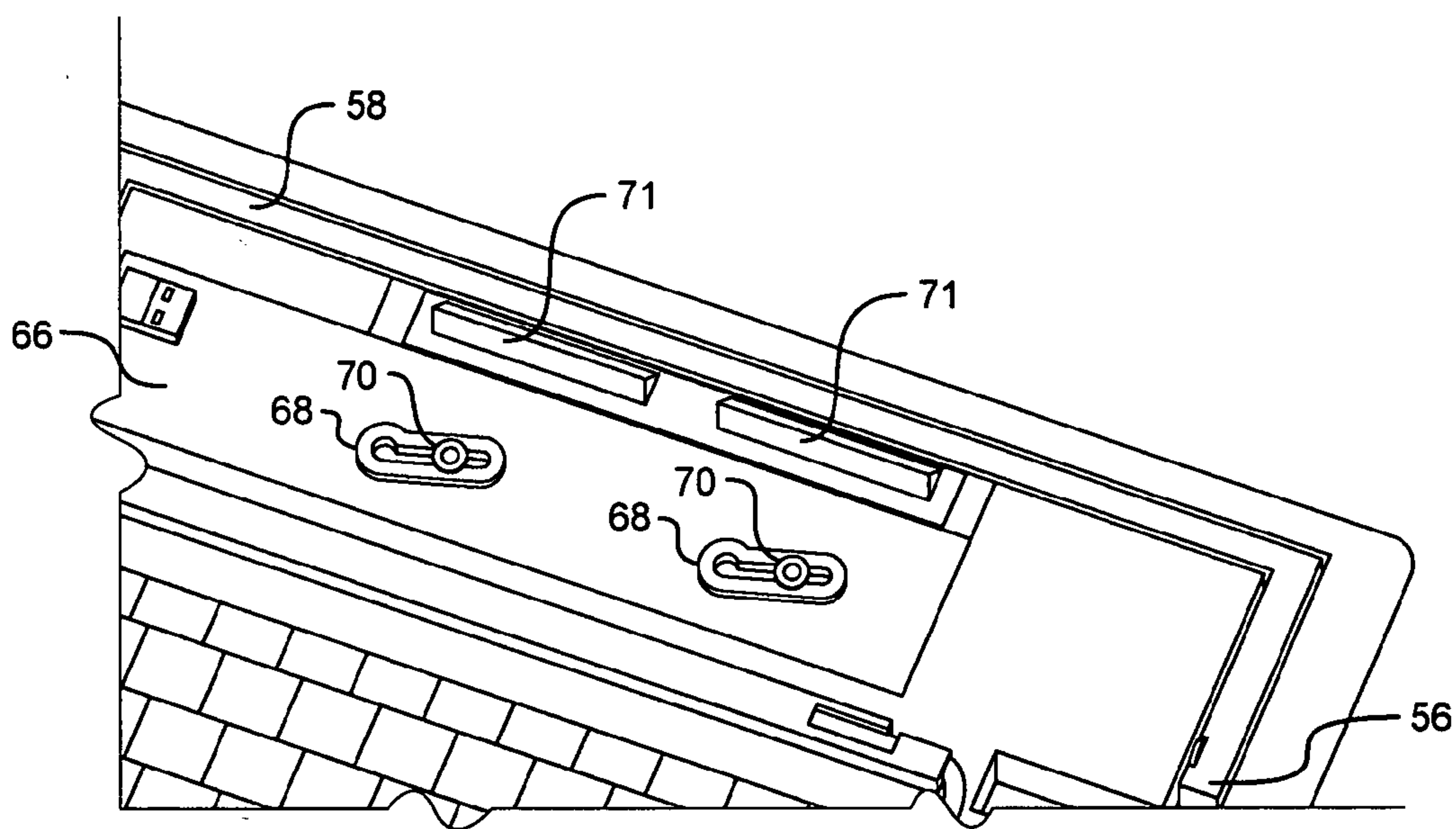
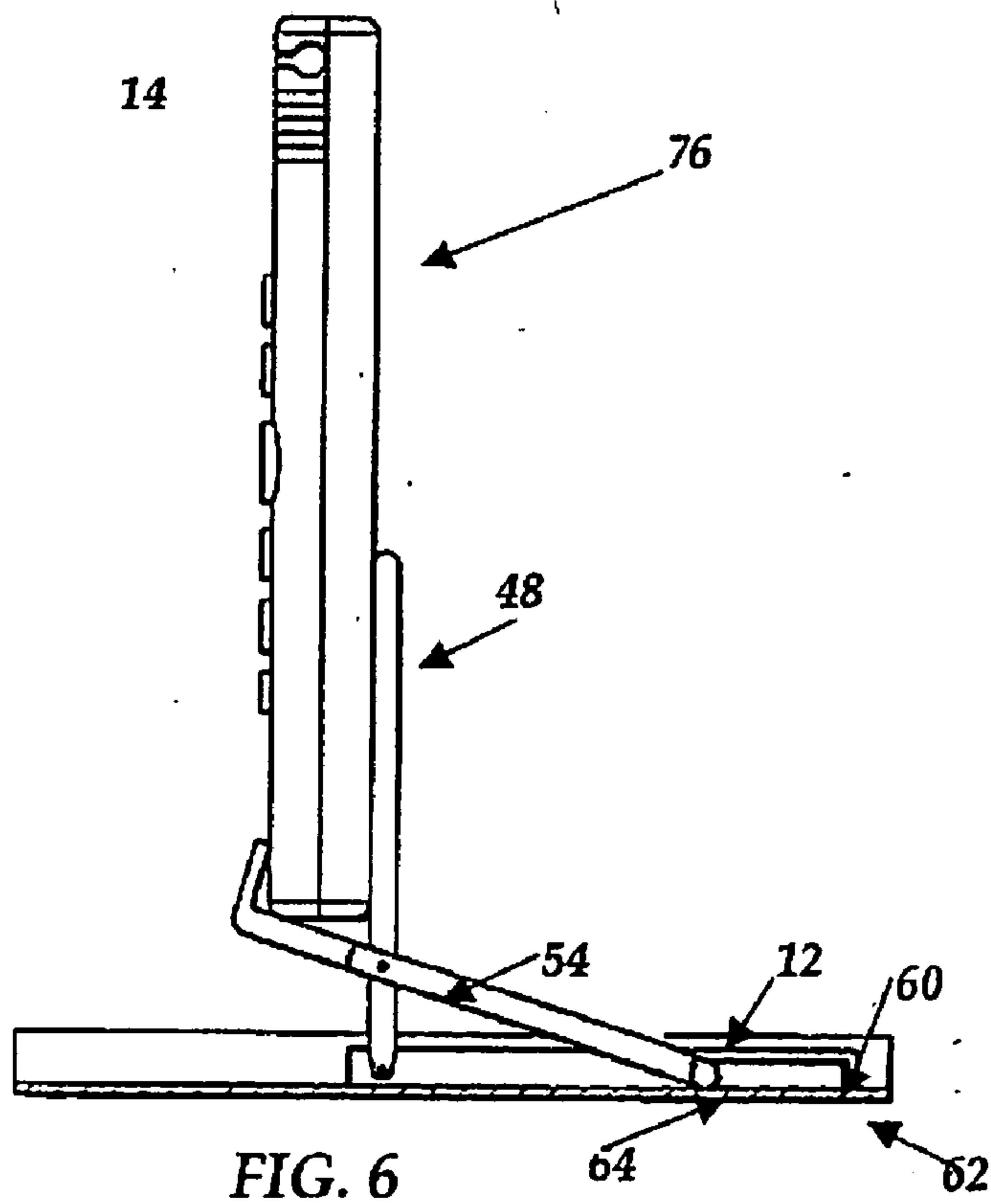
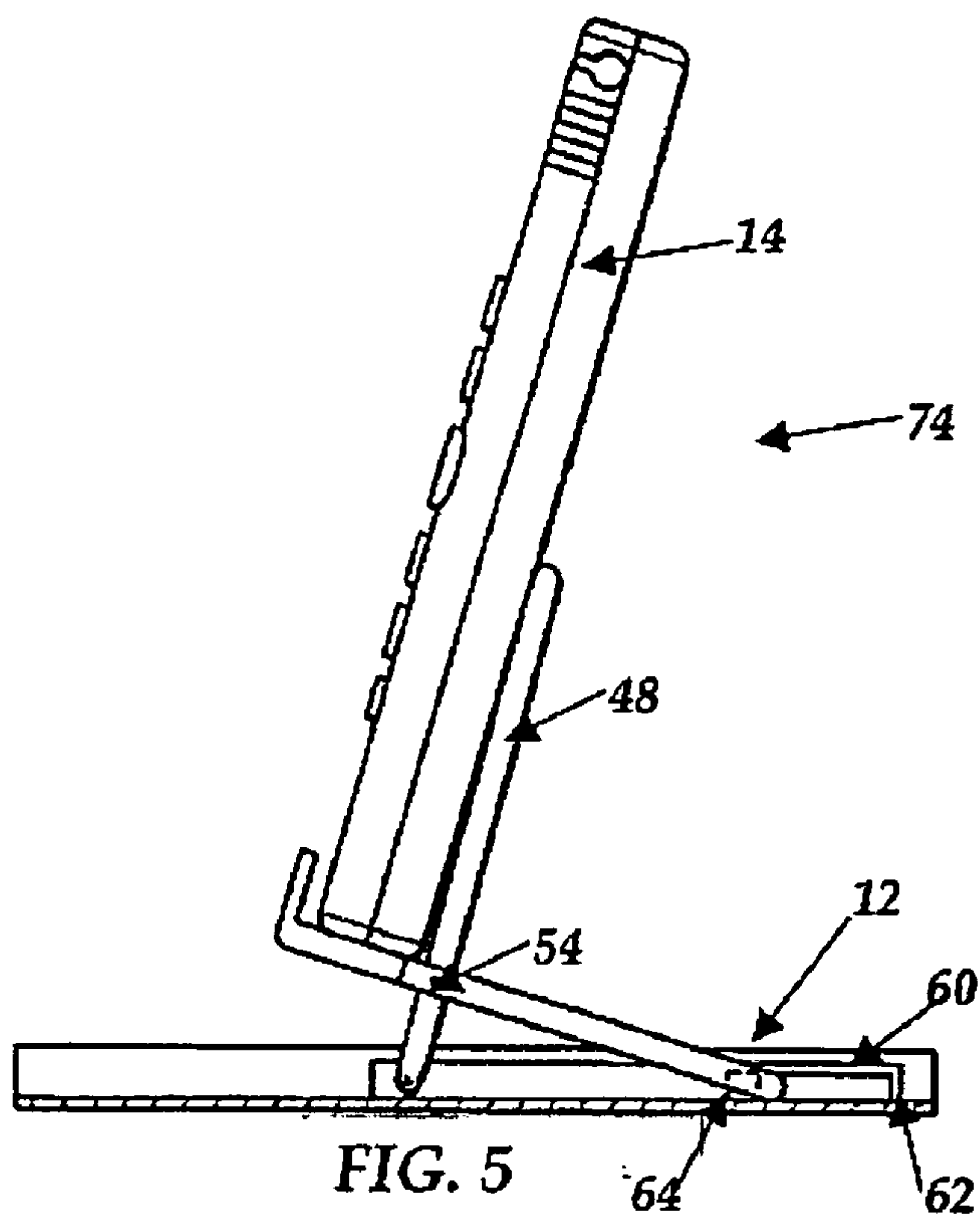

FIG. 7





**FIG. 4**



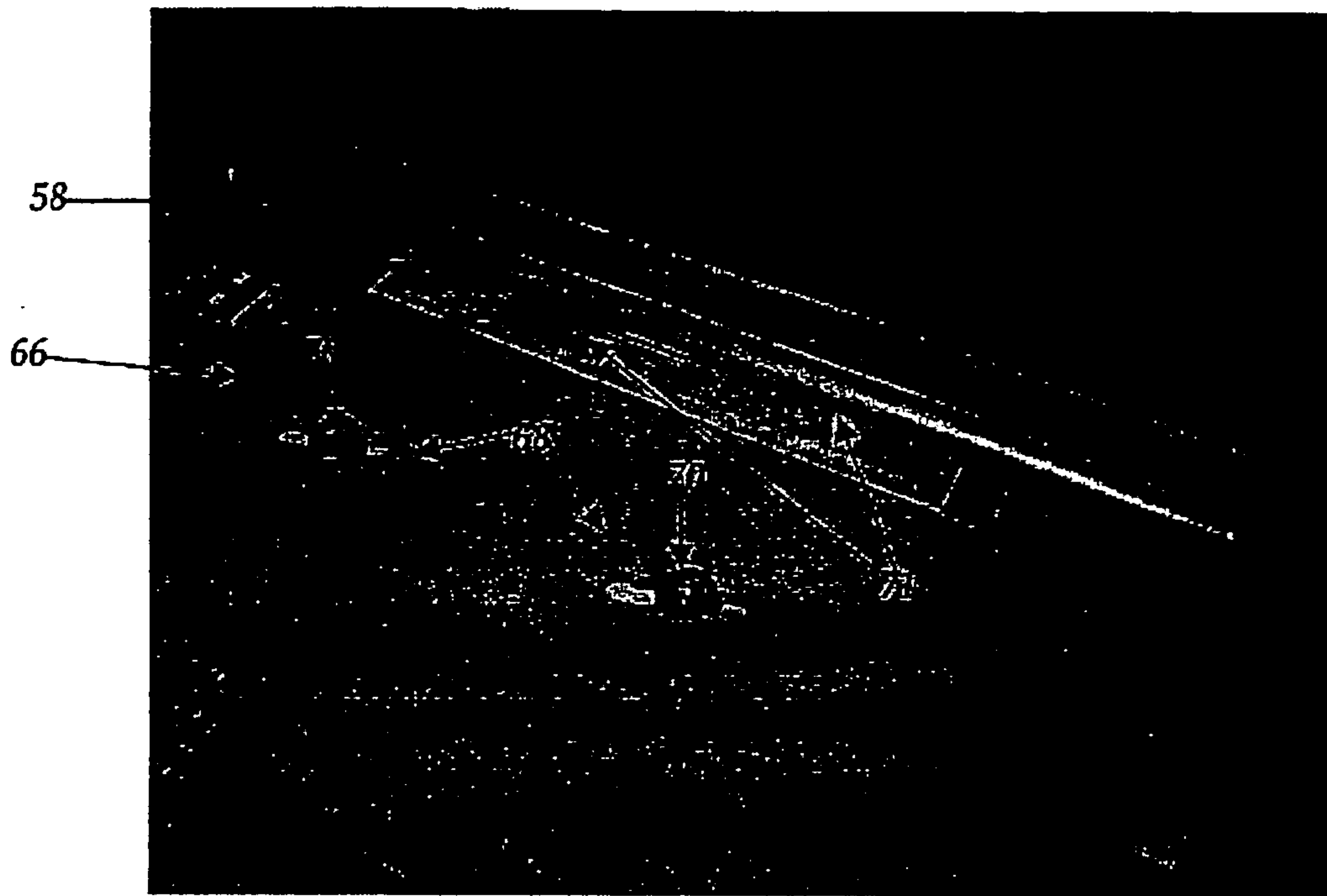

FIG. 4

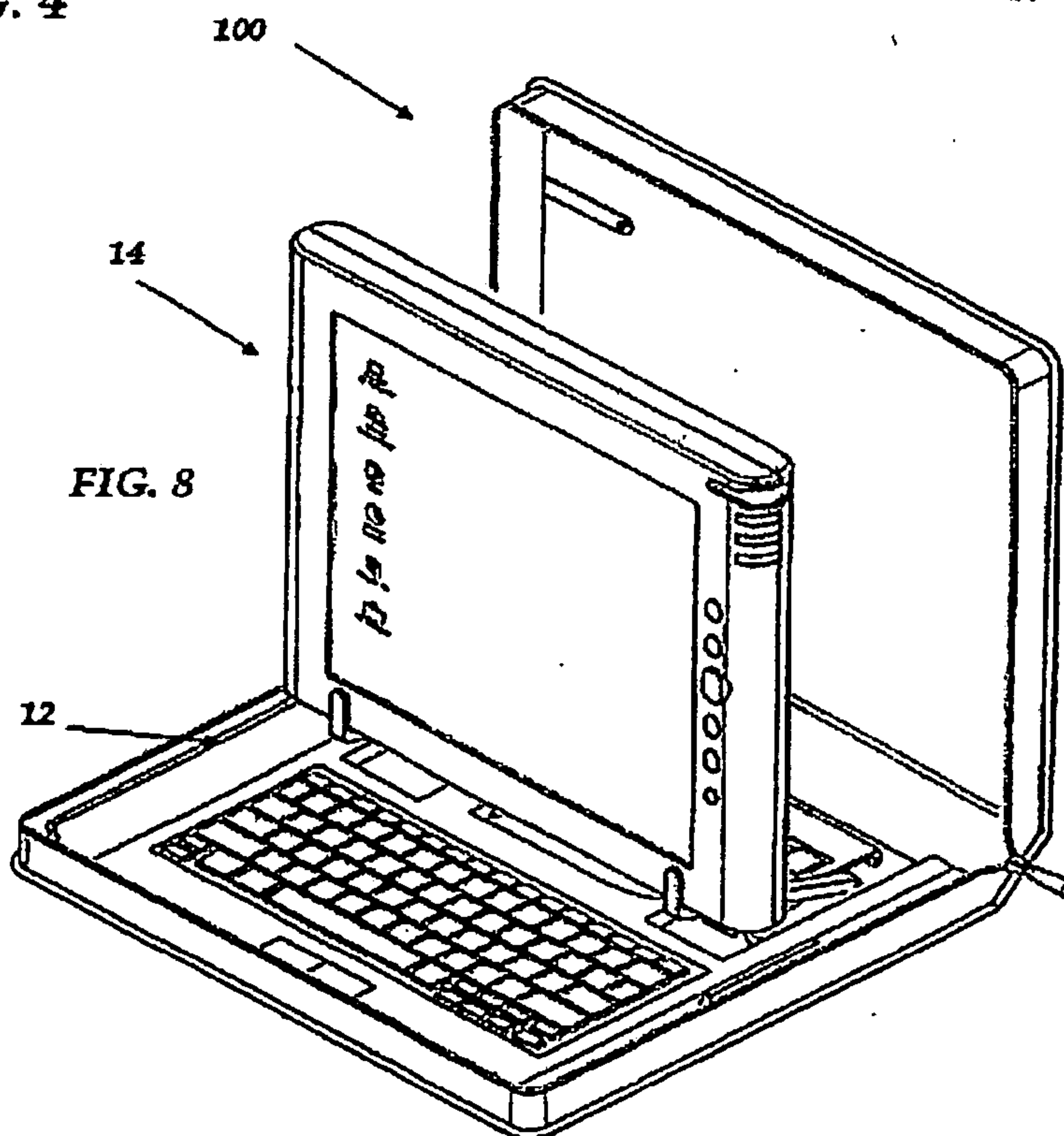
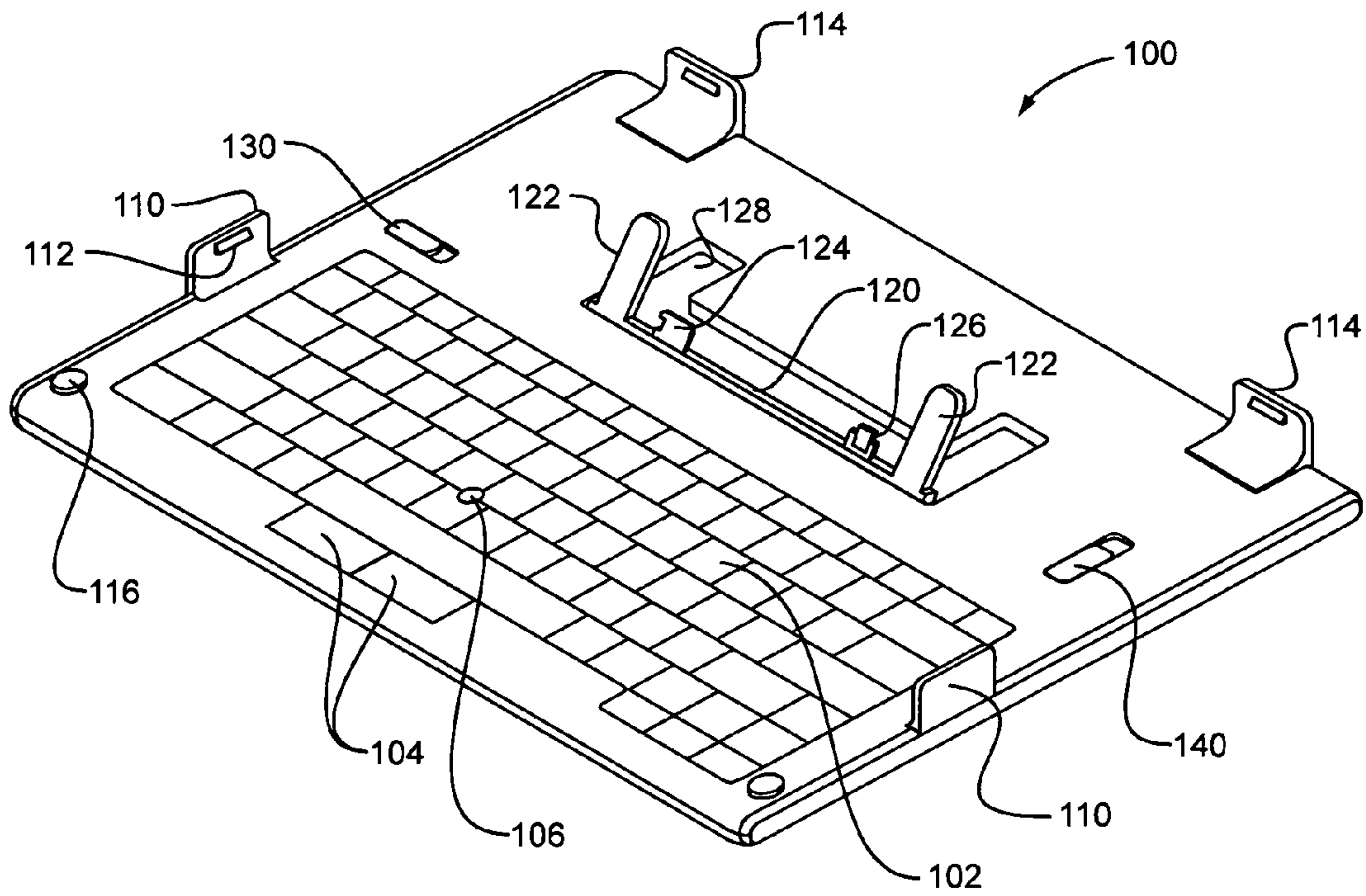

FIG. 8



**FIG. 9**

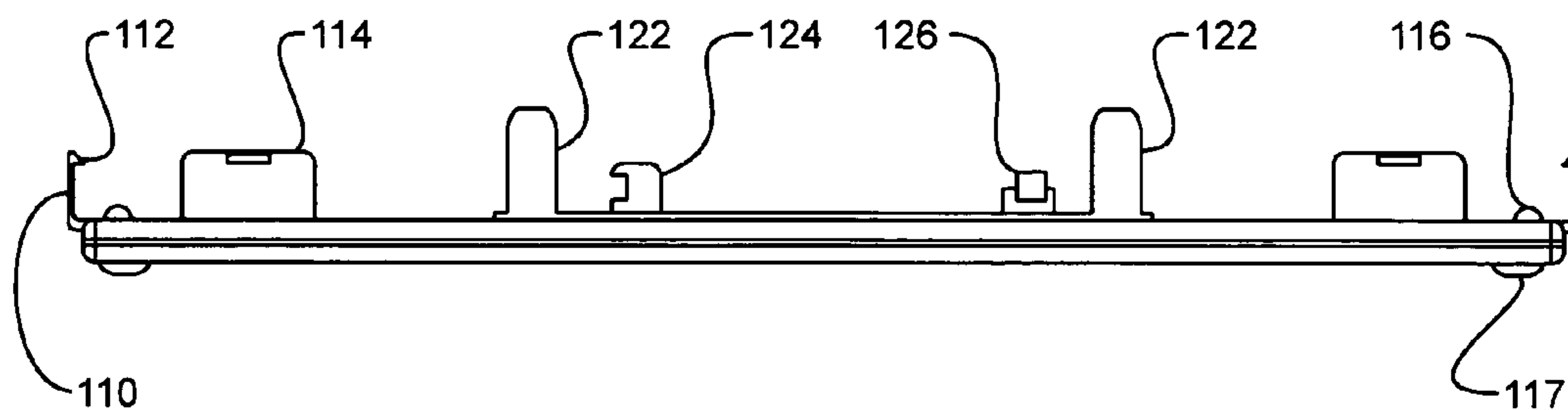

FIG. 10

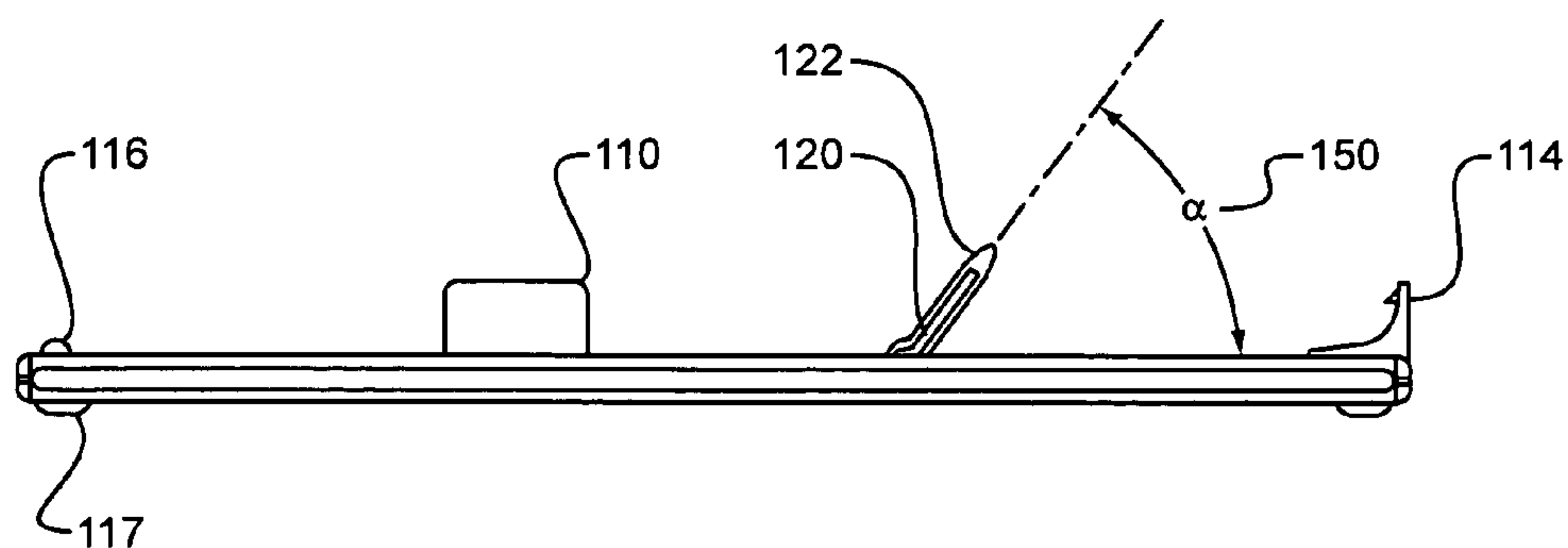
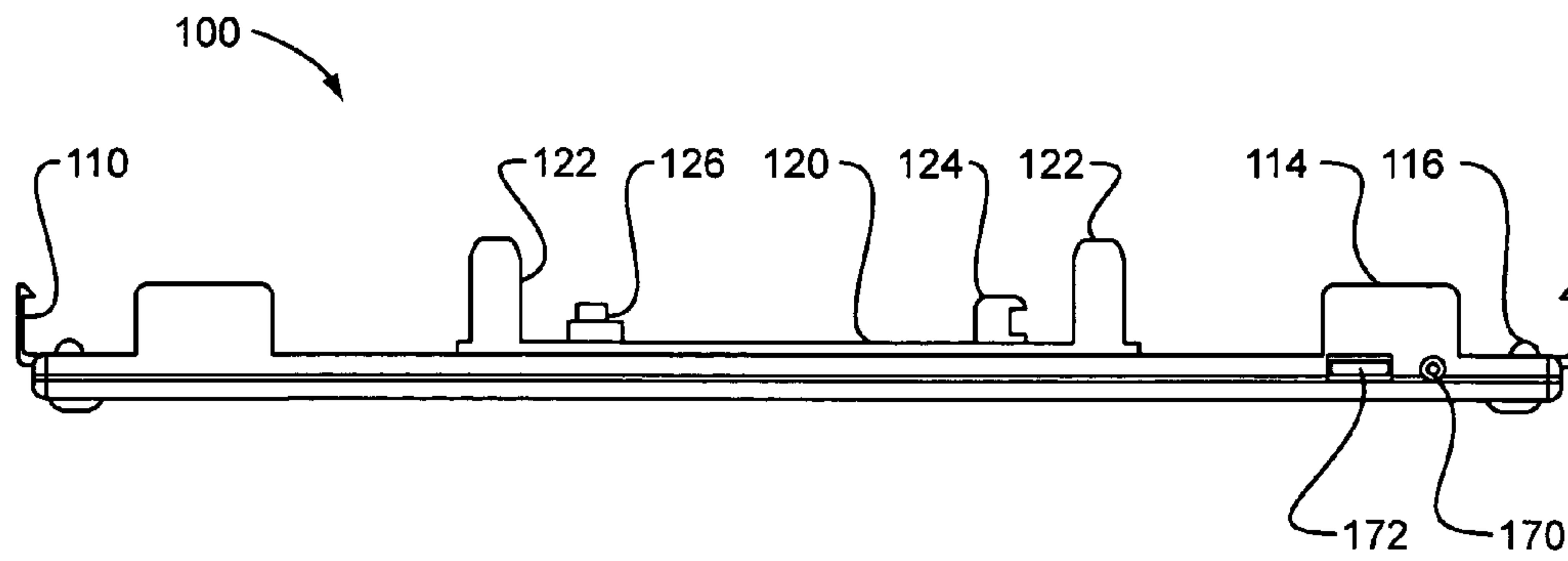
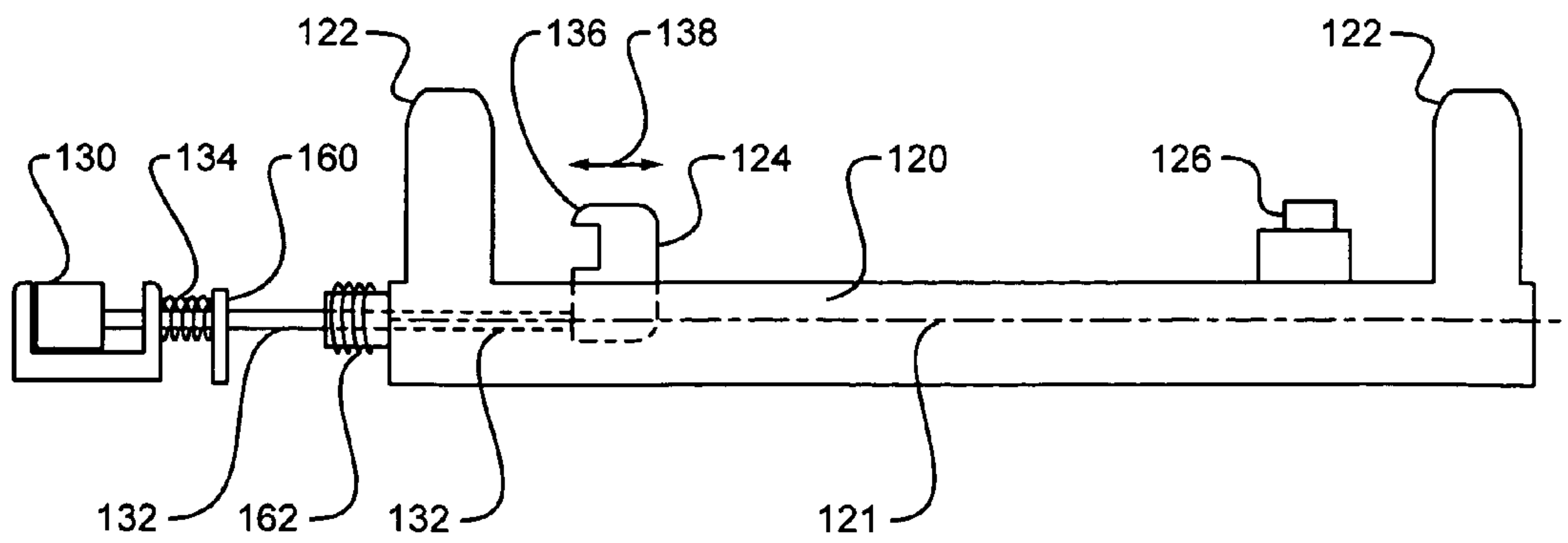

FIG. 11

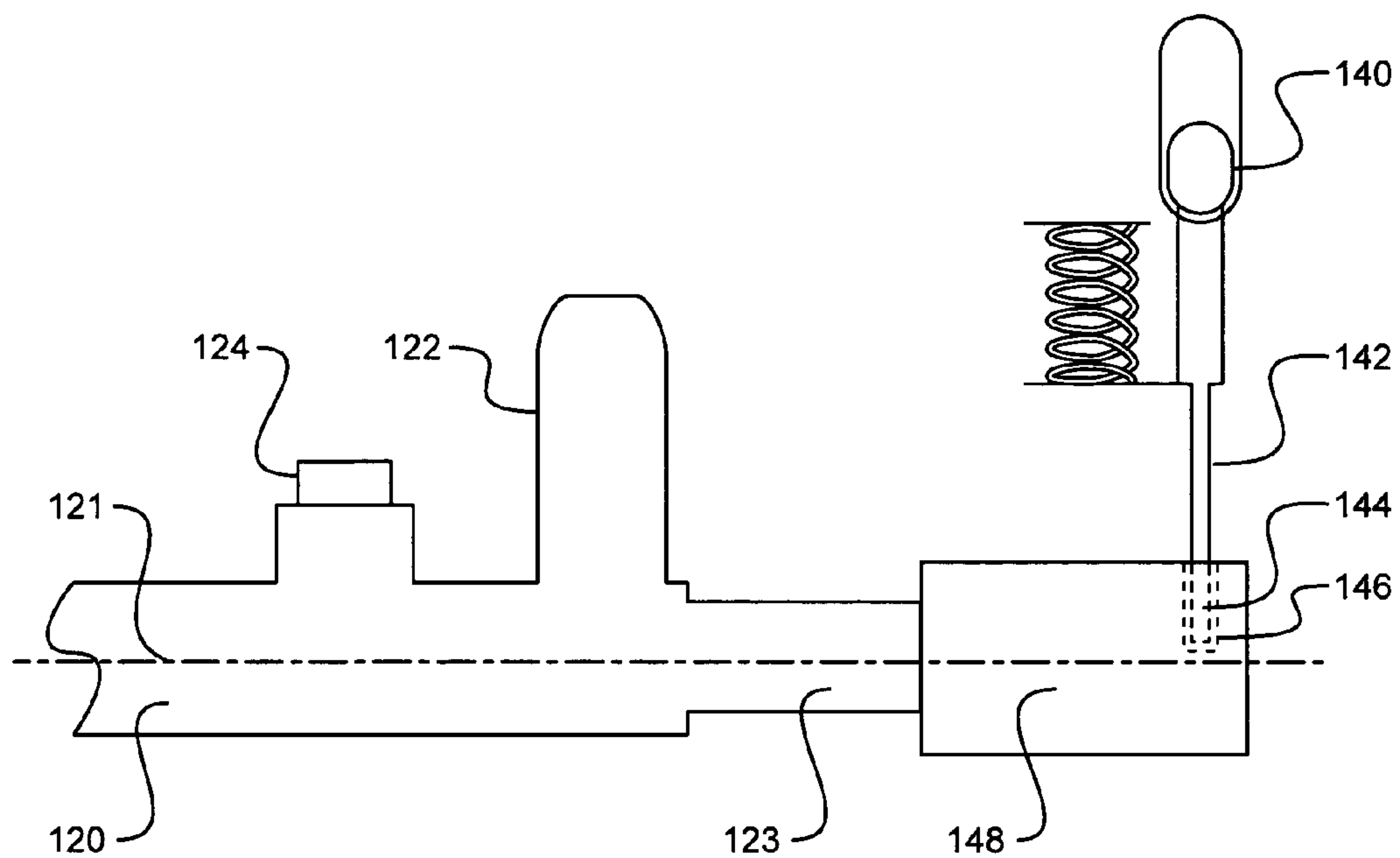



**FIG. 12**



**FIG. 13**



**FIG. 14**

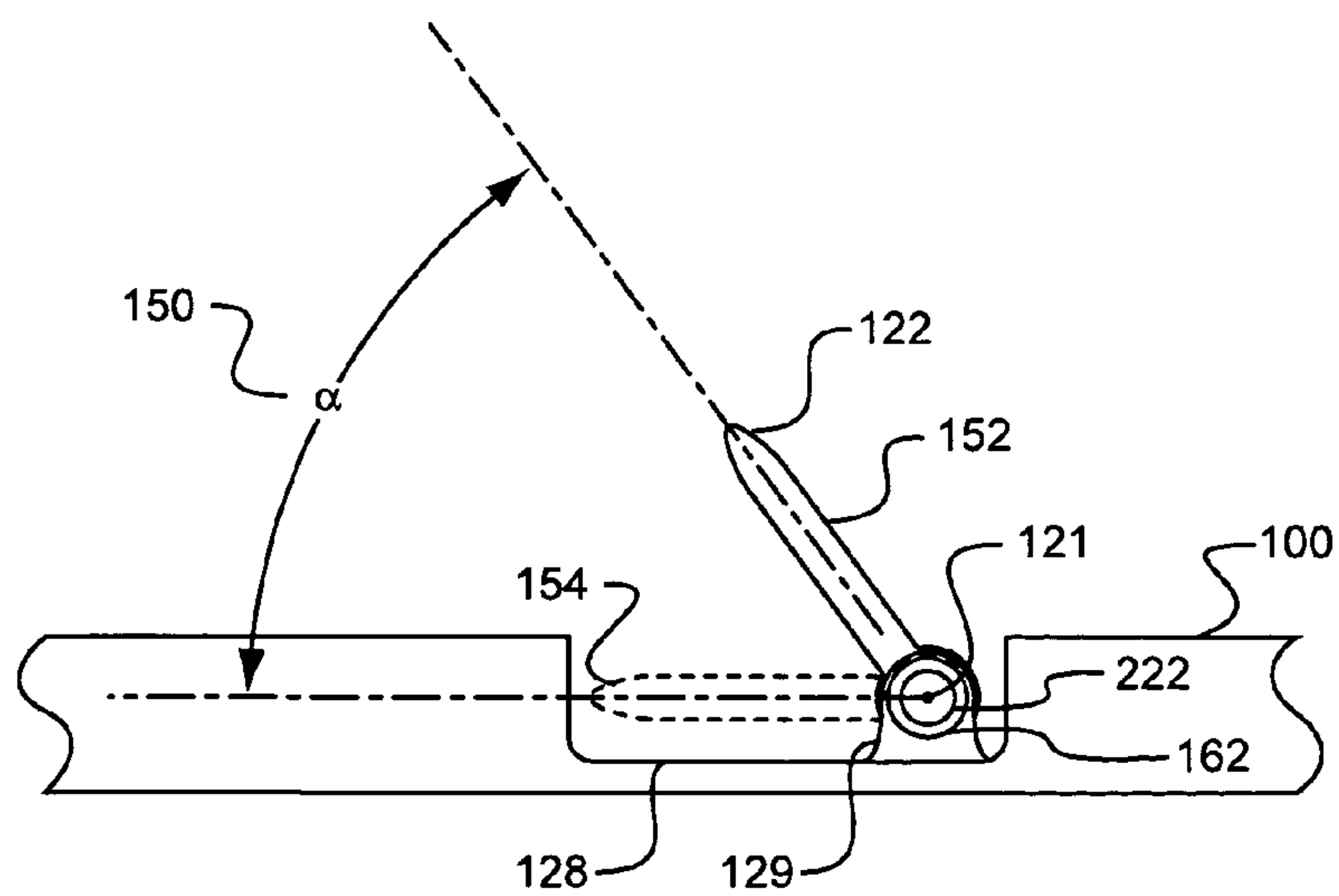

**FIG. 15**

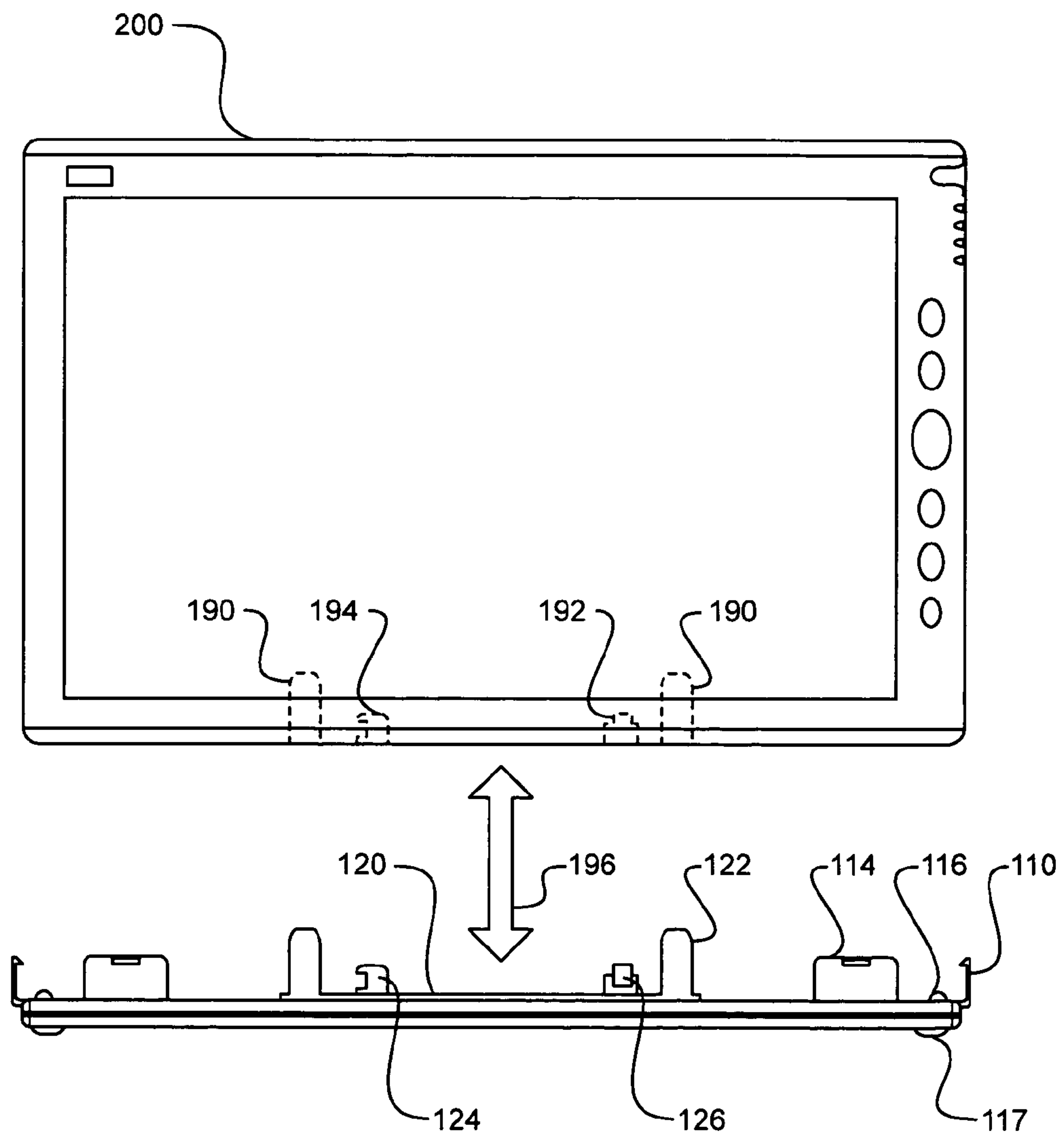

**FIG. 16**

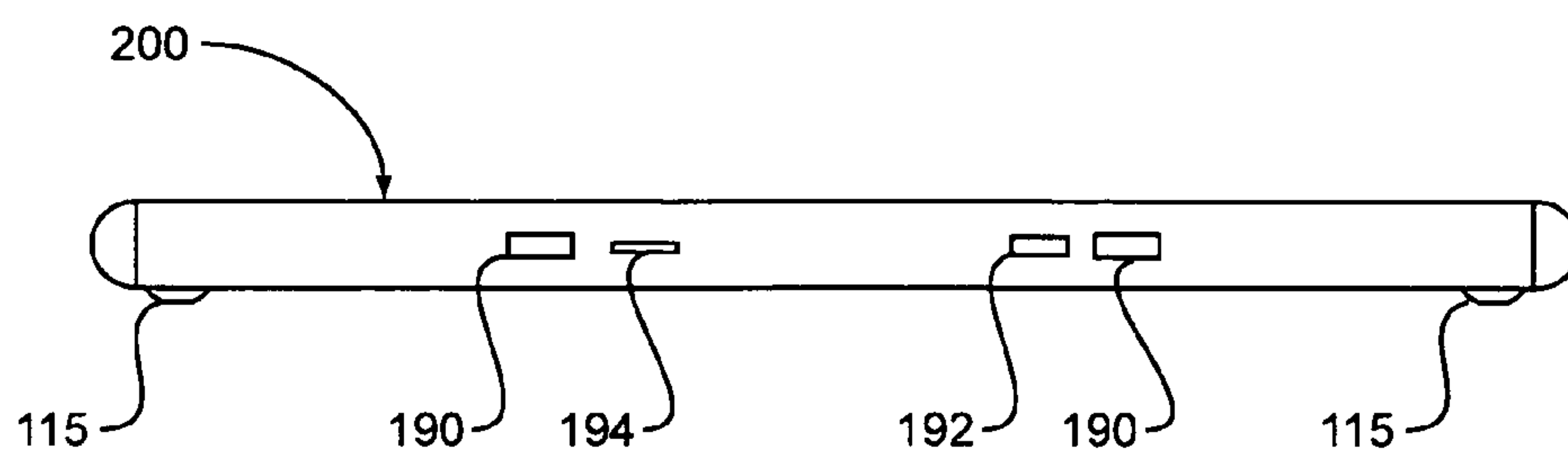

FIG. 17

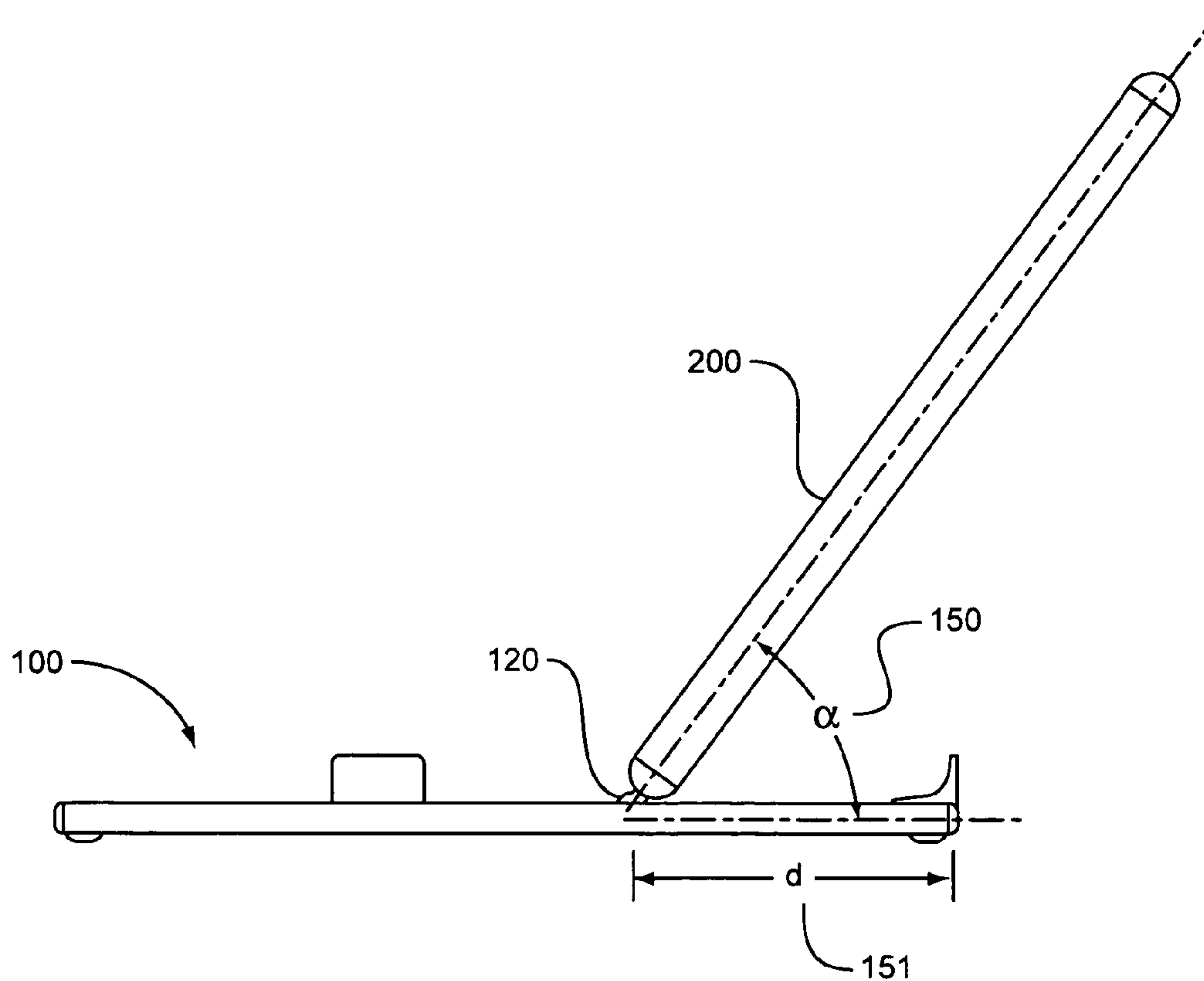
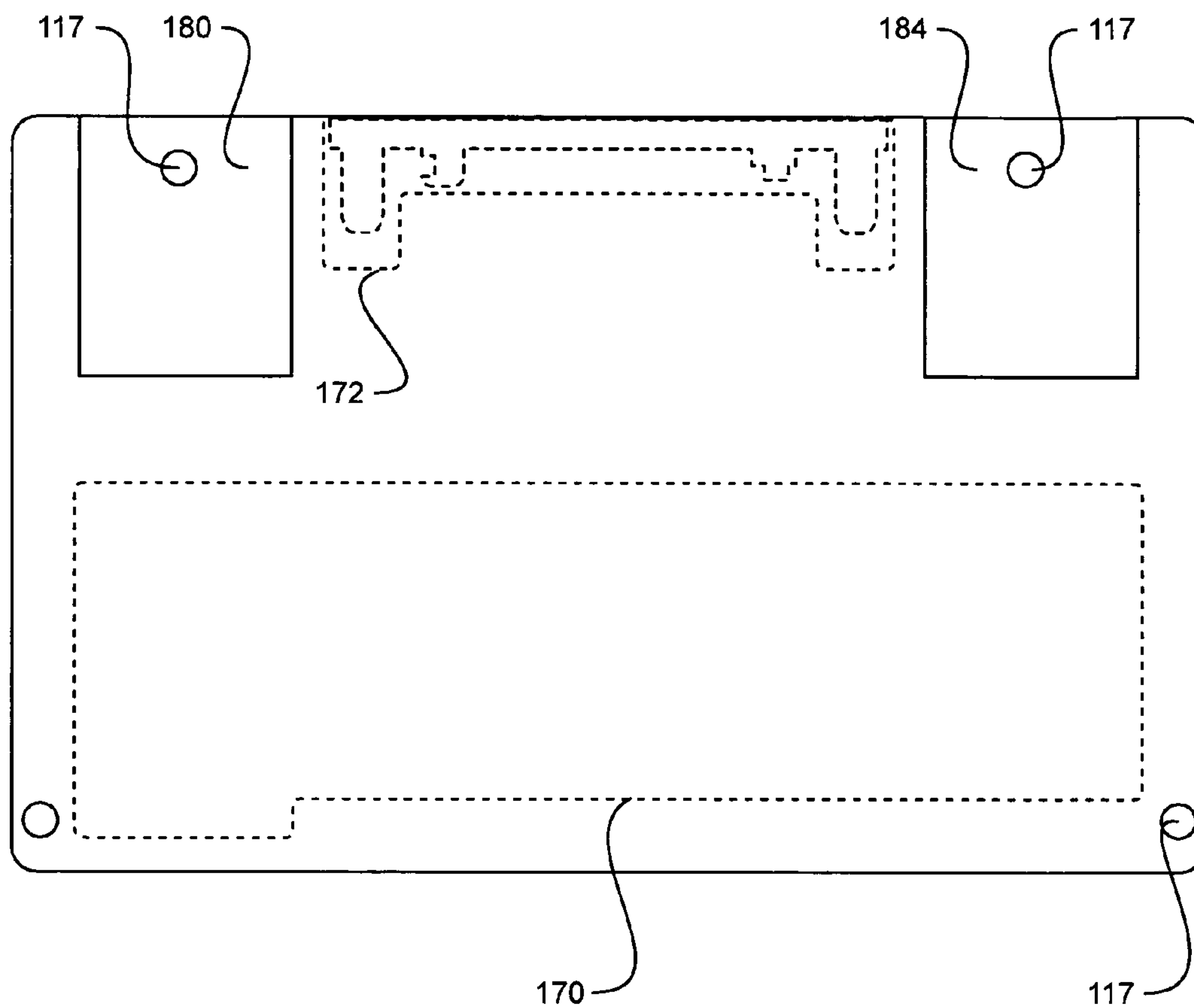
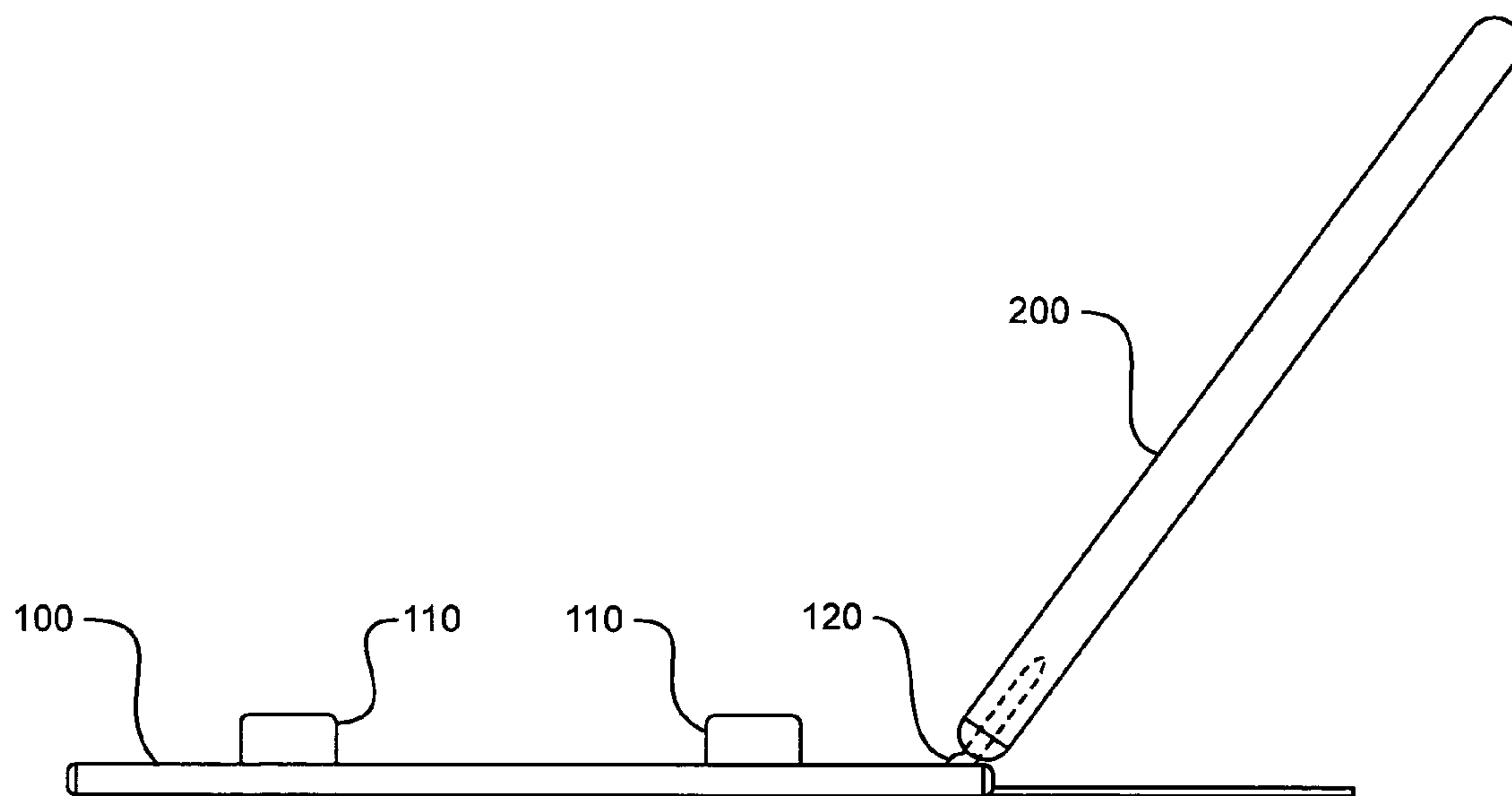

FIG. 18





**FIG. 19**



**FIG. 20**

**HINGED MOUNT COMBINED MODULAR  
KEYBOARD AND TABLET PC PROTECTIVE  
COVER**

RELATED APPLICATION

[0001] This application is a continuation-in-part of application Ser. No. 10/423,284, filed on Apr. 25, 2003, and entitled "A Combined Modular Keyboard and Tablet PC Cover", now allowed, the totality of which is incorporated herein by reference.

TECHNICAL FIELD OF INVENTION

[0002] The present invention pertains generally to electrical computers and more particularly to modular tablet computer systems and keyboards for such systems.

BACKGROUND OF THE INVENTION

[0003] Personal computers have recently become very popular for a variety of uses ranging from home, office, engineering, sales, marketing, and military applications. Virtually every aspect of business, engineering and science utilizes some form of computer system on a daily basis. Since their introduction, personal computers have become increasingly compact while simultaneously becoming increasingly powerful. This progression of smaller and more powerful personal computers has reached the point that some personal computer manufacturers are providing a tablet personal computer, or "tablet PC."

[0004] The tablet PC is a fully functional personal computer, which may include a Microsoft Windows® operating system. The tablet PC not only is capable of running familiar productivity applications such as Microsoft's Word®, Excel® and PowerPoint®, but also offers the same rich connectivity to the Internet that a desktop or notebook PC provides.

[0005] In addition, the table PC adds the simplicity of pen and paper, because the user can write on the screen with a stylus for data input. The table PC is designed to work well with all types of input devices. However, those who find it most attractive are typically business computer users who spend some part of their day away from their desks. These users not only desire the use of the pen operating system, but also frequently have uses for which the traditional keyboard provides the best input device. For example, today's tablet PC provides effective handwriting recognition software. However, for longer documents and other applications, a keyboard provides the most efficient means for data input.

[0006] Unfortunately, using a keyboard requires the table PC user to carry the keyboard while moving from place to place. The need to carry along the keyboard, however small or compact, militates against the advantages of using the tablet PC. Accordingly, there is a need for a device that eliminates the requirement of carrying a keyboard in the mobile use table PC.

[0007] In accordance with the present invention, a combined modular keyboard and tablet PC protective cover is provided that substantially eliminates or reduces the disadvantages and problems associated with prior keyboard and related input devices for tablet PCs and similar devices.

[0008] According to one aspect of the invention, there is provided a modular keyboard to which the tablet personal

computer can be integrally mounted and dismounted. The modular keyboard can also be mounted and dismounted to the tablet computer to provide a cover that protects the display screen and control and input keys on the face of the tablet computer. In accordance with another aspect of the invention, the relative angle between the modular keyboard and tablet computer can be adjusted when the tablet computer is mounted to the modular keyboard.

[0009] Another technical advantage of the present invention is power and data connection(s) which are integral to the mounting of the tablet to the modular keyboard.

[0010] Another technical advantage of the present invention is that the variable-angle mounting device can also provide different levels of resistance to modification of its angular configuration. For ease of use in configuring the modular keyboard either as a keyboard input device or as a protective cover for the tablet computer.

[0011] Other technical advantages are readily apparent to one skilled in the art from the following figures, description, and claims.

BRIEF DESCRIPTION OF THE DRAWINGS

[0012] For a more complete understanding of the present invention and advantages thereof, reference is made to the following description taken in conjunction with the accompanying drawings in which like reference numbers indicate like features and where:

[0013] **FIG. 1** shows a combined view of the modular keyboard and base unit forming the table PC of the present invention;

[0014] **FIG. 2** provides an isometric view of the modular keyboard of the present invention;

[0015] **FIG. 3** shows the combination of the base unit and modular keyboard of the present invention;

[0016] **FIG. 4** illustrates the underside of the positioning plate of the present invention;

[0017] **FIGS. 5 AND 6** show two positions obtainable using the modular keyboard of the present invention;

[0018] **FIG. 7** depicts the modular keyboard of the present invention in a stowed configuration;

[0019] **FIG. 8** illustrates one use of the modular keyboard of the present invention in a portfolio;

[0020] **FIG. 9** illustrates an isometric view of an alternative embodiment of the modular keyboard of the present invention;

[0021] **FIG. 10** illustrates a front-side view of the embodiment of the modular keyboard illustrated in **FIG. 9**;

[0022] **FIG. 11** illustrates a right-side view of the embodiment of the modular keyboard illustrated in **FIG. 9**;

[0023] **FIG. 12** illustrates a back-side view of the embodiment of the modular keyboard illustrated in **FIG. 9**;

[0024] **FIG. 13** illustrates an embodiment of a locking mechanism for the modular keyboard illustrated in **FIG. 9**;

[0025] **FIG. 14** illustrates an embodiment of a resistive clutch release for the modular keyboard illustrated in **FIG. 9**;



[0026] FIG. 15 illustrates mounting angle(s) for a tablet computing device on the modular keyboard illustrated in FIG. 9 and stowing away of the hinge mount;

[0027] FIG. 16 illustrates the mounting or dismounting of a tablet computing device on the modular keyboard illustrated in FIG. 9;

[0028] FIG. 17 illustrates the mountable side of the tablet computing device mountable on the modular keyboard illustrated in FIG. 9;

[0029] FIG. 18 illustrates a tablet computing device mounted to the modular keyboard so that the angle of orientation between the keyboard and the tablet computer can be adjusted;

[0030] FIG. 19 illustrates bottom view of an alternative embodiment of a hinge mount embodiment of a combination modular keyboard and cover for a tablet computer; and

[0031] FIG. 20 illustrates a right-side view of the embodiment illustrated in FIG. 19 with the stabilization extensions extended.

#### DETAILED DESCRIPTION OF THE FIGURES

[0032] The preferred embodiment of the present invention and its advantages are best understood by referring to FIGS. 1 through 20 of the drawings, like numerals being used for like and/or corresponding parts of the various drawings.

[0033] FIG. 1 shows table PC 10, which includes modular keyboard 12 and base unit 14. Modular keyboard 12 includes a hard protective outer side 16 for protecting screen 18 of base unit 14. Side clasps 20 and 22 form a friction fit to sides 24 and 26, respectively, of base unit 14. Rubber feet 28 on outer side 16 permit placing tablet PC 10 in an inverted position on a smooth surface to prevent slipping. Base unit 14 includes hot keys 30 and 32, scroll key 34, function key 36 and escape key 38. Pen holder 40 holds a pen-based input device or stylus adjacent LEDs 42. Modular keyboard 12 covers and protects from physical damage all of these keys and devices upon be secured to sides 24 and 26 of base unit 14.

[0034] Tablet PC 10 provides a fully functional computer system which can accommodate an alphanumeric keyboard and provides connections for various input and output signals. Specifically, tablet PC 10 provides connectors for a telephone jack, parallel port connections, serial port connections, display data connections, and a power connector. In one embodiment, tablet PC 10 may be modified to include a full computer address and data bus as well as a variety of peripheral components. Peripheral devices such as a disk drive and a numeric keypad may communicate with the tablet PC 10. Tablet PC 10 also provides for data input and manipulation using a stylus or pen for control without the need for a keyboard. The stylus may be used for entering text and graphic information, as well as any of a number of computer control commands.

[0035] In the illustrated embodiment, modular keyboard 12 is partially formed from a plastic casing comparable in composition to the plastic of base unit 14. In an alternative embodiment, however, modular keyboard 12 may be formed, at least in part, from a softer foam rubber or plastic, such as that used in automobile dashboards, preferably with a hard plastic internal ribbing or frame. The softer casing

could provide adequate structural support while absorbing more impact (from a drop from a table, for example) than a typical hard plastic casing. The softer foam may also provide improved comfort for a user holding the tablet in his or her hand or lap.

[0036] FIG. 2 shows modular keyboard 12 inverted and in position for supporting base unit 14. Modular keyboard 12 includes key array 44, which is integrally attached to inner side 46 of modular keyboard 12. For supporting base unit 14, modular keyboard 12 includes back support 48, which includes rests 50 upon which base unit 14 may rest in a stationary position. Back support 48 pivots about joints 52, which are also integral to inner side 46 of modular keyboard 12. Side support arms 54 pivotally join back support 48 at joints 56 to provide generally vertical support for base unit 14, as base unit 14 rests on rest pads 50 of back support 48.

[0037] Key array 44 provides a standard QWERTY key array; however, other key arrangements may be used equally well. As well as providing desired alphanumeric input keys, key array 44 provides LEDs for indicating "CAP LOCK," and "NUM LOCK" or others functions or status under which key array 44 may be operating.

[0038] Side support arms 54 connect to or may be integrally formed with position bar 58. Note that the present embodiment uses two separate side support arms 54. However, a single support bar or more than two side support arms may be used as a side support mechanism within the scope of the invention. Position bar 58 may be moved laterally along guides 60. Moving position bar 58 changes the position of joints 56 in relation to joints 52. Thus, position bar 58 moving toward back ends 62 of guides 60 will cause joints 56 to move in a backward direction. This causes back support 48 to incline away from the vertical. Alternatively, moving position bar 58 in the direction of front ends 64 of guides 60, causes back support 48 to assume a more vertical position.

[0039] Position plate 66 controls the position of position bar 58 and includes a lateral cam that moves laterally for controlling the angle of back support 48. FIG. 4, below, more particularly describes the operation of the lateral cam for adjusting position plate 66.

[0040] USB cable 78 connects through keyboard base 72 to the electronic circuitry associated with key array 44. As a result, data input from key array 44 may feed into base unit 14. Moreover, base unit 14 may provide electrical power via USB cable 78 for operating circuitry associated with LEDs and key array 44 electronic circuitry. Recess 80 receives the disconnected USB cable 78. This causes USB cable 78 to assume a profile beneath the plane which keyboard base 72 establishes. Moreover, USB cable 78 is of a short length that, while permitting connection to an associated USB port (not shown) on connector side 82 of base unit 14, requires only minimal possible space and thickness in fitting USB cable 78 within the profile or thickness of keyboard base 72.

[0041] In an alternative embodiment of the present invention, instead of USB cable 78, there may be a wireless data connection between key array 44 and base unit 14. A wireless data connection may be established between key array 44 and the base unit 14 using an IrDA interface, although other wireless interfaces, including a radio frequency interface are in accordance with the present inven-



tion. Other embodiments, however, may provide an alternate wired data connection among these components, such as a power/data wire connecting the key array to base unit 14.

[0042] FIG. 3 shows base unit 14 in position with support along back side 84 provided by back support 48, while side support arms 54 provide essentially vertical support. Side support arms 54 also include securing feet 86. Securing feet 86 include rubber covers 88, which not only facilitate a friction fit between securing feet 86 and back support 48, but also prevent or substantially reduce side movement of base unit 14 relative to modular keyboard 12. This results in a substantially rigid and secure combined base unit 14 and modular keyboard 12 forming tablet PC 10.

[0043] Securing feet 86 may, in one embodiment, be loaded with a torsion spring that causes them to automatically position vertically to secure base unit 14. Thus, once side support arms are raised, the associated torsion spring would snap securing feet 86 from a horizontal orientation a vertical orientation relative to inner side 46. For closing, securing feet are manually positioned back in the horizontal orientation, thereby loading the torsion spring and making securing feet 86 ready to snap to the vertical in the next use. Such a mechanism would prevent the placement of base unit 14 on side support arms 54 in a less safe position not using securing feet 86.

[0044] FIG. 4 provides an underside view of position plate 66 to show more specifically its operation. In particular, position plate includes lateral cam slots 68 which receive fasteners 70, which may be pins, screws or other fastening devices, for securing position plate 66 relative to keyboard base 72. Due to the angular disposition of lateral cam slots 68, shifting of positioning plate 68 from side to side causes positioning plate 66 to simultaneously translate from front to back. Because position bar 58 is integrally attached to position plate 66 at joints 71, such movement further causes position bar 58 to move front to back. The movement of position bar 58 changes the relative positions of joints 52 of back support 48 and joints 56 connecting back support 48 to side support arms 54. The result will be a change in the angular view of base unit 14 when resting on back support 48.

[0045] FIGS. 5 and 6 illustrate two possible positions that base unit 14 may assume to provide a fully adjustable angle of display to the user. Thus, FIG. 5 shows base unit 14 at an angle off of the vertical, whereas FIG. 6 depicts base unit 14 in a fully vertical position. Referring also briefly to FIG. 2, translating positioning plate 66 from a first position 74 to a second position 76 along lateral cam slots 68 moves position bar 58 to any desired position from back ends 62 to front end 64 of guides 60. This permits an essentially infinite number of angular positions that back support 48 may assume in presenting to the user screen 18 of base unit 14.

[0046] Although the preferred embodiment of the present invention provides lateral cam slots 68 for controlling the tilt angle of back support 48, other types of cam devices may be used. Moreover, an alternative embodiment of the present invention may provide for no adjustment at all, but simply provide that back support 48 alternate between a retracted position and a supporting position. For variable adjustment, the present invention may provide a rotating cam device that permits position adjustments for position of position bar 58. Alternatively, instead of providing a continuous type of

position adjustment mechanism, an alternative embodiment may provide for a number of fixed or discrete variable positions that into which position bar 58 be positioned. All such varieties of positions and position establishing mechanisms are within the scope of the present invention.

[0047] FIG. 7 illustrates a principal advantage of the present invention: the ability to provide the fully supported base unit 14 with modular keyboard 12 in a form factor having a minimal height when in a stowed position, which modular keyboard also provides a secure stand for supporting base unit 14. Thus, stowed configuration 88 depicts USB cable 78 stowed within recess 80 of keyboard base 72. Back support 48 stows in recess 90, into which position securing tab 92 assures no vertical movement out of the stowed position. Due to their own dimensions, side support arms 54 and position bar 58 stow within the perimeter which back support 48 defines within recess 90. Note also that securing feet 86 of side support arms 54 pivot to permit their lateral stowage within recess 94. Thus, securing feet 86 assume a stowed position not greater than the height of keyboard base 72.

[0048] In stowed configuration 88, the modular keyboard 12 height 96 equals the thickness of keyboard base 72. Consequently, modular keyboard 12 provides the combined benefit of serving as a protective cover for base unit 14 and as a standard data entry device using key array 44.

[0049] FIG. 8 illustrates a further embodiment of the present invention, whereby tablet PC 10 rests within portfolio 100. Portfolio 100 may, for example, provide a secure attachment to outer side 12 of modular keyboard 12. This would permit both the stowage of tablet PC 10 within portfolio 100, while tablet PC 10 immediately configurable to the supported positions such as FIGS. 3, 5 and 6 depict.

[0050] FIG. 9 illustrates an alternative embodiment of protective cover 100 for a tablet computer that includes an integral keyboard array 102. In the embodiment shown, a pointing device 106 is also integral to the protective cover 100. In fact in the embodiment shown the pointing device 106 is integral to the keyboard array 102 which in turn is integral to the cover 100. In the embodiment shown the pointing device has associated push button inputs 104 which are integral to the use of the pointing device. The embodiment shown illustrates what is commonly called an eraser-head mouse. In alternative embodiment other pointing devices may be integrated in the cover such as track balls or track pads. Additionally, it should be appreciated that the pointing device is not necessary to the functionality of the computer—particularly since the tablet computer provides alternative pointing device means such as an input stylus (not shown).

[0051] The modular cover 100 also includes mounting clips 110 & 114 with registration extensions 112 for temporary fixable mounting of the cover to the tablet computer. These mounting clips and registrations are configured to align with a mate with counterparts (not shown) on the tablet computer. Although the registrations 112 illustrated protrude from the mounting extensions 110 so that they mate with indentions (not shown) in the tablet computer in other embodiments the mounting extensions 110 may have indentions that mate with extensions on the tablet computer. In other embodiments other methods may be employed to mount the cover 100 to the tablet computer in a configura-



tion that provides protection to the tablet computer. The cover also provides protective offsets 116 to provide separation between the tablet computer and the cover 100. In a preferred embodiment it is preferable that the modular cover can be mounted to cover and protect either the display screen side of the tablet computer or the backside of the tablet computer. In this way the user can take off the protective cover from the front where it was protecting the display and mount it on the back of the tablet to stow it while the tablet is used with its stylus rather than the keyboard.

[0052] The embodiment illustrated in FIG. 1 includes a hinge mount 120 to which the tablet computer can be mounted to the modular cover 100 in a configuration where the modular cover 100 can be used as an input keyboard array for the user to input information into the tablet computer. The hinge mount 120 includes mounting registration arms 122 which also serve as lever arms to rotate the hinge mount 120. The hinge mount 120 also includes an integral electrical connector 126. In the embodiment shown this integral electrical connector includes USB power and data communications between the keyboard and the tablet computer.

[0053] In the embodiment shown the hinge mount also includes an integral automatic locking mechanism 124. When the tablet computer is mounted on the registration arms and lowered on to the hinge mount 120, the locking mechanism 124 engages the tablet computer so that it is locked in place on the keyboard cover 100. When the user decides to dismount the tablet computer from the hinge mount 120 a locking mechanism release 130 is provided to disengage the locking mechanism 124.

[0054] The embodiment shown also provides an indented section 128 for stowing the hinge mount 120 in a position where it will not interfere with the use of the modular keyboard/cover 100 as a protective cover. The cover 100 also includes a resistive clutch release 140 which will be discussed in greater detail below.

[0055] FIG. 10 provides a front-side illustration of the embodiment of the modular keyboard illustrated in FIG. 9. This view illustrates the components of the hinge mount 120 including the registration arms 122, the locking mechanism 124 and the electrical connector 126. This figure also illustrates mounting clips 110 & 114 and offsets 116 described above. In addition this figure illustrates skid resistant friction pads 117.

[0056] FIG. 11 provides a right-side illustration of the embodiment of the modular keyboard illustrated in FIG. 9. From this view the mounting hinge 120 angle  $\alpha$ 150 at which the tablet computer (not shown) will be mounted on the registration lever arms 122. In the embodiment illustrated, this angle is variable and is maintained once set by the user by a friction clutch (not shown in this figure). FIG. 11 also illustrates mounting clips 110 and 114 which are used to mount the cover to the tablet computer as a protective cover. Previously described spacers 116 and friction pads 117 are also shown.

[0057] FIG. 12 illustrates a backside illustration of the cover 100. The protective cover mode clips 110 and 114 are illustrated. From this view the mounting hinge 120 can be seen with its registration/lever arms 122; its locking mechanism 124; and electrical power/data connection(s) 126.

[0058] FIG. 13 illustrates in greater detail the locking release mechanism of the hinge mount 120. As previously described, when the tablet computer is mounted on the hinge mount 120, the locking mechanism 124 engages the tablet computer and extension 136 of the locking mechanism holds the tablet computer in place on the hinge mount 120. The locking mechanism can be released by engaging locking mechanism release lever 130. By engaging the locking release mechanism 130, pushrod 132 moves the locking mechanism 124 in direction 138. A spring 134 maintains the locking mechanism 124 in a locked position. FIG. 13 also illustrates a second spring 162. This spring 162 is related to the position of the hinge mount in connection with the resistive clutch release described below.

[0059] FIG. 14 illustrates in greater detail the resistive clutch release mechanism. The hinge mount 120 is mounted to cover 100 so that its rotation relative to cover 100 is relatively unencumbered. In order to maintain an angular position of the hinge mount 120, a resistive clutch 148 is used. This resistive clutch provides a relatively high level of friction between itself and extension 123 of the hinge mount 120. With the resistive clutch engaged, the hinge mount is difficult to rotate without the leverage provided by a tablet computer mounted to the registration/lever arms 122 of the hinge mount 120. The resistance provided by the resistive clutch should be sufficient to hold the tablet at the desired angle but not so much so that the angle cannot be adjusted to the angle desired by the user within an allowable range.

[0060] Once the tablet computer is dismounted a different level of resistance is desired to allow the user to stow away the hinge extension arms 122 so that the cover 100 can be used as a protective cover without interference from the hinge mount 120. In the embodiment shown, this different level of resistance is provided by a resistive clutch release mechanism. In the embodiment shown the resistive clutch release mechanism is a spring 142 loaded release 140. The release 140 is comprised of a slide release lever 140 which removes a pin 144 from a hole 146 in the resistive clutch 148. When the pin is engaged in the hole 146 in the resistive clutch 148 the resistive clutch 148 does not rotate and provides resistance to the rotation of the hinge mount 120. A spring 142 maintains the pin 144 in a position where it engages the resistive clutch 148. When the slide lever is engaged by the user, the pin 144 is withdrawn from the hole 146 and the resistive clutch is allowed to freely rotate. If the pin is withdrawn when the tablet computer is not mounted on the hinge mount, spring 162 (FIGS. 13 and 15) causes the hinge mount 120 to retract into opening 128 (FIG. 15) so that it is stowed away and the cover can be mounted to the tablet computer as a protective cover without interference from the hinge mount. The resistive clutch 148 remains disengaged until the user rotates the hinge mount 120 back into a position where the pin 144 lines up with the hole 146 in the resistive clutch 148. In alternative embodiments, other mechanisms could be employed to vary the resistance to rotation of the hinge mount. In the alternative in other embodiments the hinge mount can be fixed into one or more fixed angular positions.

[0061] FIG. 15 illustrates a side view of the hinge mount. Mounted to the cover by mounting 129. This view illustrates the mounting hinge 120 in a mounting position 152 and in a stowed position 154 in the indent 128 in the cover 100. Spring 162 is also illustrated in this view. Spring 162 is



loaded so that it drives the hinge into position **154** when the resistive clutch **148** (shown in **FIG. 14**) is released.

[0062] **FIG. 16** illustrates a tablet computer **200** mounting to the hinge mount **120** on the modular keyboard cover **100**. The registration arms **122** of the hinge mount align to mate with registration holes **190** in the tablet computer **200**. At the same time the electrical connector **126** align to mate with its mating connector **192** on the tablet computer **200** and the locking mechanism **124** aligns to mate with its counterpart **194** in the tablet computer **200**.

[0063] **FIG. 17** illustrates a side view of the tablet computer illustrating the alignment holes **190** electrical connector **192** and locking mechanism counterpart **194**.

[0064] **FIG. 18** illustrates a tablet computer **200** mounted to the modular keyboard cover **100** in a configuration for receiving input from the modular keyboard **100**. In the embodiment illustrated, the hinge mount **120** is positioned a distance  $d$  inside the edge of the cover **100**. This inset serves several functions. One function is the stability of the mounted tablet computer **200**. With most mobile computing devices it is desired to keep the components light. This applies to the modular keyboard cover as well. The weight of the modular keyboard cover **100** is very light relative to the weight of the tablet computer **200** which mounts to the modular keyboard **100**. Therefore the hinge mount **120** is positioned a distance  $d$  **151** from the back edge of the cover. This distance  $d$  is a function of the minimum angle  $\alpha$  **150** allowed by the hinge mount **120** when the tablet computer **200** is mounted to the hinge mount **120**. The inset of the hinge mount **120** keeps the mounted tablet computer **200** stable when it is angled back ( $\alpha$  is decreased). If the distance  $d$  is too short, then at some point as the tablet computer is angled back ( $\alpha$  decreases), the combined unit will become unstable and topple backwards. In alternative embodiments the cover could include extendable extensions so allow for the hinge to be mounted closer to or on the edge of the cover **100**.

[0065] In addition to a more stable unit, positioning the hinge mount **120** inset from the back edge of the cover **100** provides other advantages. For example, the display of the tablet computer **200** is closer to the user. Another advantage is that it provides for an overall smaller footprint especially when the tablet computer is angled back. This smaller footprint is particularly useful in small spaces such as an airplane tray table. Where the passenger seat in front of the user can become an encumbrance particularly when the passenger in that seat decides to recline the seat backrest.

[0066] In one embodiment of the present invention, the height of the mounted tablet computer is approximately 9 inches the inset  $d$  **151** of the hinge mount **120** from the back side of the cover **100** is approximately 3 inches and the range of angular configurations of the mounted tablet computer is just over  $90^\circ$  to approximately  $60^\circ$ . The complementary range of angles between the display and the keyboard array is just under  $90^\circ$  to just over  $120^\circ$ . In other embodiments other dimensions are possible and likely and within the spirit of this invention.

[0067] **FIGS. 19 and 20** are illustrations of another embodiment of the present invention. **FIG. 19** is an illustration of the bottom view of the modular keyboard cover. In this embodiment the hinge mount **120** is mounted near the

edge of the cover **100**. This cover includes integrated stabilization extensions **180** and **184**. In this figure the stabilization extensions are shown in a non-extended position or stowed when not in use.

[0068] **FIG. 20** illustrates a side view of the embodiment shown in **FIG. 19** showing the tablet computer **200** mounted on the mounting hinge **120** via registration arm(s) **122** to the modular cover **100** and integrated stabilization extension **180** extended to stabilize the mounted tablet computer. The function of the extensions **180** and **184** is to provide stability to prevent the tablet computer from toppling over backwards when the tablet is angled away from the keyboard array.

[0069] In summary, therefore, there is provided by the present invention, a modular keyboard for a tablet personal computer that provides a cover on an outer side for covering the tablet computer screen and associated control and input keys. A key array for key-based data entry into the base unit mounts integrally to the inner side. A back support supports the base unit in a raised position relative to the key array and presents the base unit for monitoring data entry from the key array. The back support is retractable into a recess that is substantially parallel to the inner side. Side support arms or a similar mechanism cooperates with the back support for supporting the base unit and holding base unit securely relative to the back support. The side support arms are retractable to a recessed position substantially parallel to the inner side. A bus connector connects and communicates key-based data between the key array and the base unit.

[0070] Accordingly, it is to be understood that the embodiments of the invention herein described are merely illustrative of the application of the principles of the invention. References made herein to details of the illustrated embodiments are not intended to limit the scope of the claims, which themselves recite those features regarded as essential to the invention.

I claim:

1. A modular keyboard for a tablet personal computer comprising:

a cover with an outer side and an inner side for covering a tablet computer;

a key array mounted integrally to said inner side;

a retractable hinged mount for receiving a tablet computer in a raised position relative to said key array and presenting said tablet computer to the user for monitoring data entry from said key array.

2. The modular keyboard of claim 1, further comprising a locking mechanism for locking in place a tablet computer mounted on the hinged mount.

3. The modular keyboard of claim 1 wherein the locking mechanism is spring loaded into a locked position and includes a release for releasing the tablet computer so that it can be dismounted from the modular keyboard.

4. The modular keyboard of claim 1, wherein the angle relative to the keyboard array at which the hinge mount presents said tablet computer to the user can be adjusted before or after said tablet computer is mounted to the hinge mount.

5. The modular keyboard of claim 1 further comprising a data communications link for communications between the modular keyboard and the tablet computer.



6. The modular keyboard of claim 5 wherein the data communications link is integral to the hinge mount so that the data communication linkage is established automatically when said tablet computer is mounted on said hinge mount.

7. The modular keyboard of claim 5 wherein the data communications link is wireless.

8. The modular keyboard of claim 1 wherein the hinge mount is retractably associated with said inner side to retract into a recess when the keyboard is to be used as a cover.

9. The modular keyboard of claim 1 wherein the hinge mount has at least two levels of resistance to rotation whereby a lower level of resistance is provided for stowing and unstowing the hinge and a higher level of resistance is provided when said tablet computer is mounted on the hinge mount.

10. The modular keyboard of claim 9 further where in two levels of resistance to rotation are provided by a resistive clutch and a resistive clutch release.

11. The modular keyboard of claim 10 wherein the resistive clutch release is spring loaded so that the release seeks to maintain the clutch in a nonreleased state.

12. The modular keyboard of claim 10 wherein

the hinge mount is retractably associated with said inner side to retract into a recess when the keyboard is to be used as a cover; and

the hinge mount is spring loaded so that when the clutch release is activated to release the resistive clutch the hinge mount retracts into said recess for receiving said hinge mount in a stowed position.

13. A tablet personal computer comprising:

a monitor display unit

a cover for covering a tablet computer with an outer side and an inner side;

a key array mounted integrally to said inner side of said cover;

a retractable hinged mount for receiving said monitor display unit in a raised position relative to said key array and presenting said monitor display to the user for monitoring data entry from said key array.

14. The modular keyboard of claim 13, further comprising a locking mechanism for locking in place the monitor display mounted on the hinged mount.

15. The modular keyboard of claim 14 wherein the locking mechanism is spring loaded into a locked position and includes a release for releasing the monitor display so that it can be dismantled from the modular keyboard.

16. The modular keyboard of claim 13, wherein the angle relative to the keyboard array at which the hinge mount presents said monitor display to the user can be adjusted before or after said tablet computer is mounted to the hinge mount.

17. The modular keyboard of claim 13 further comprising a data communications link for communications between the modular keyboard and the monitor display.

18. The modular keyboard of claim 17 wherein the data communications link is integral to the hinge mount so that the data communication linkage is established automatically when said monitor display is mounted on said hinge mount.

19. The modular keyboard of claim 17 wherein the data communications link is wireless.

20. The modular keyboard of claim 13 wherein the hinge mount is retractably associated with said inner side to retract into a recess when the keyboard is to be used as a cover.

21. The modular keyboard of claim 13 wherein the hinge mount has at least two levels of resistance to rotation whereby a lower level of resistance is provided for stowing and unstowing the hinge and a higher level of resistance is provided when said monitor display is mounted on the hinge mount.

22. The modular keyboard of claim 21 further where in two levels of resistance to rotation are provided by a resistive clutch and a resistive clutch release.

23. The modular keyboard of claim 22 wherein the resistive clutch release is spring loaded so that the release seeks to maintain the clutch in a nonreleased state.

24. The modular keyboard of claim 12 wherein

the hinge mount is retractably associated with said inner side to retract into a recess when the keyboard is to be used as a cover; and

the hinge mount is spring loaded so that when the clutch release is activated to release the resistive clutch the hinge mount retracts into said recess for receiving said hinge mount in a stowed position.

\* \* \* \* \*