

(19) **United States**

(12) **Patent Application Publication**
Oakes

(10) **Pub. No.: US 2005/0183962 A1**

(43) **Pub. Date: Aug. 25, 2005**

(54) **SYSTEM AND METHOD FOR GENERATING HYDROGEN GAS USING RENEWABLE ENERGY**

(52) **U.S. Cl. 205/340; 205/628**

(76) **Inventor: Thomas W. Oakes, La Mesa, CA (US)**

(57) **ABSTRACT**

Correspondence Address:
William J. Kolegraff
3119 Tumberry Way
Jamul, CA 91935 (US)

A system and method for generating hydrogen gas is described. The system uses a vessel for holding an electrolyte solution. A membrane is arranged in the vessel to form a chamber, and a cathode electrode is positioned in the chamber and in the electrolyte solution. An electric current is applied to the cathode, and with a cooperating anode, produces hydrogen gas using an electrolysis process. The membrane traps the hydrogen in the chamber, and assists in keeping the hydrogen separate from oxygen or other gasses. The hydrogen gas is exhausted from chamber for further refining, storage, or use.

(21) **Appl. No.: 10/785,234**

(22) **Filed: Feb. 24, 2004**

Publication Classification

(51) **Int. Cl.⁷ C25B 1/02**

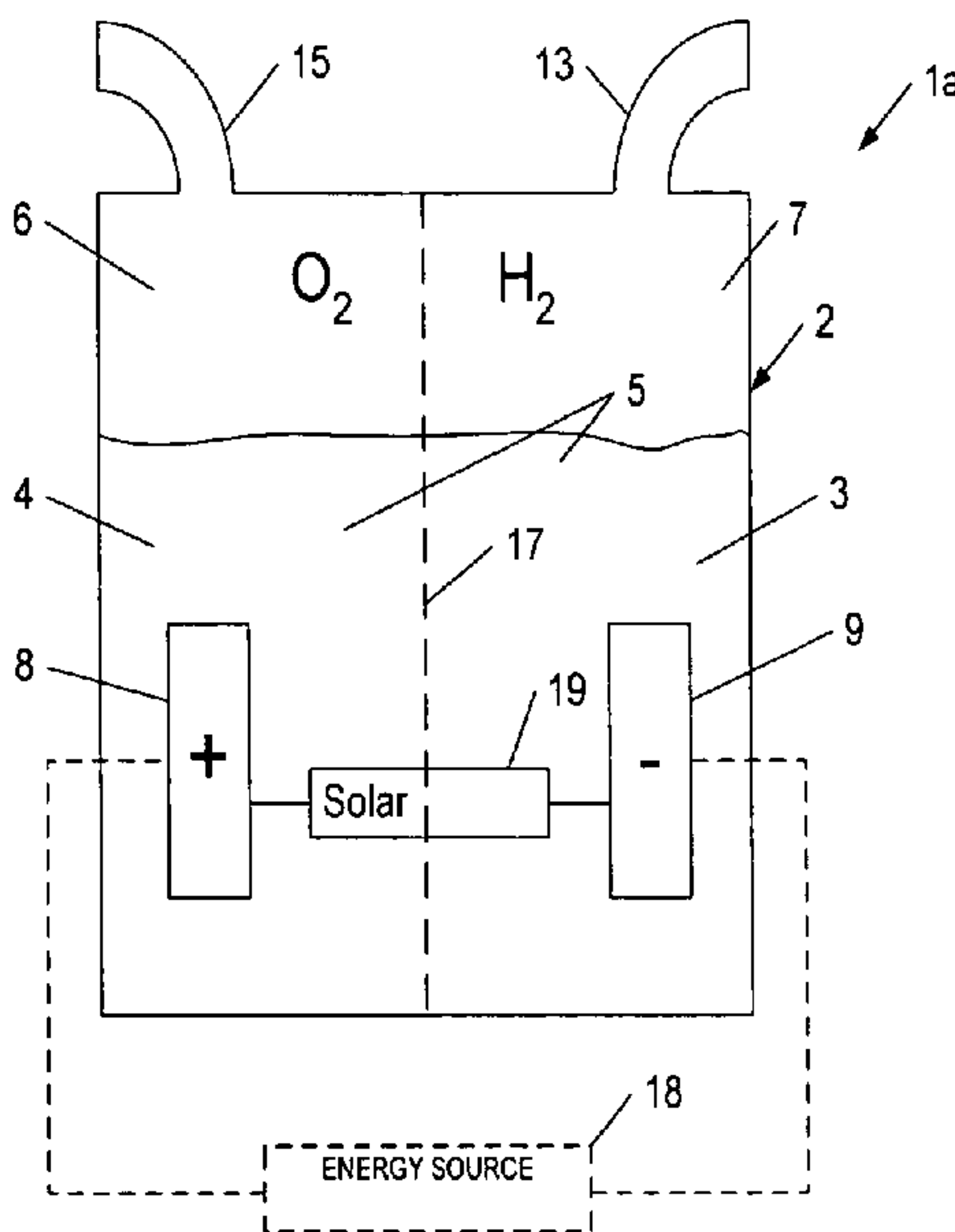
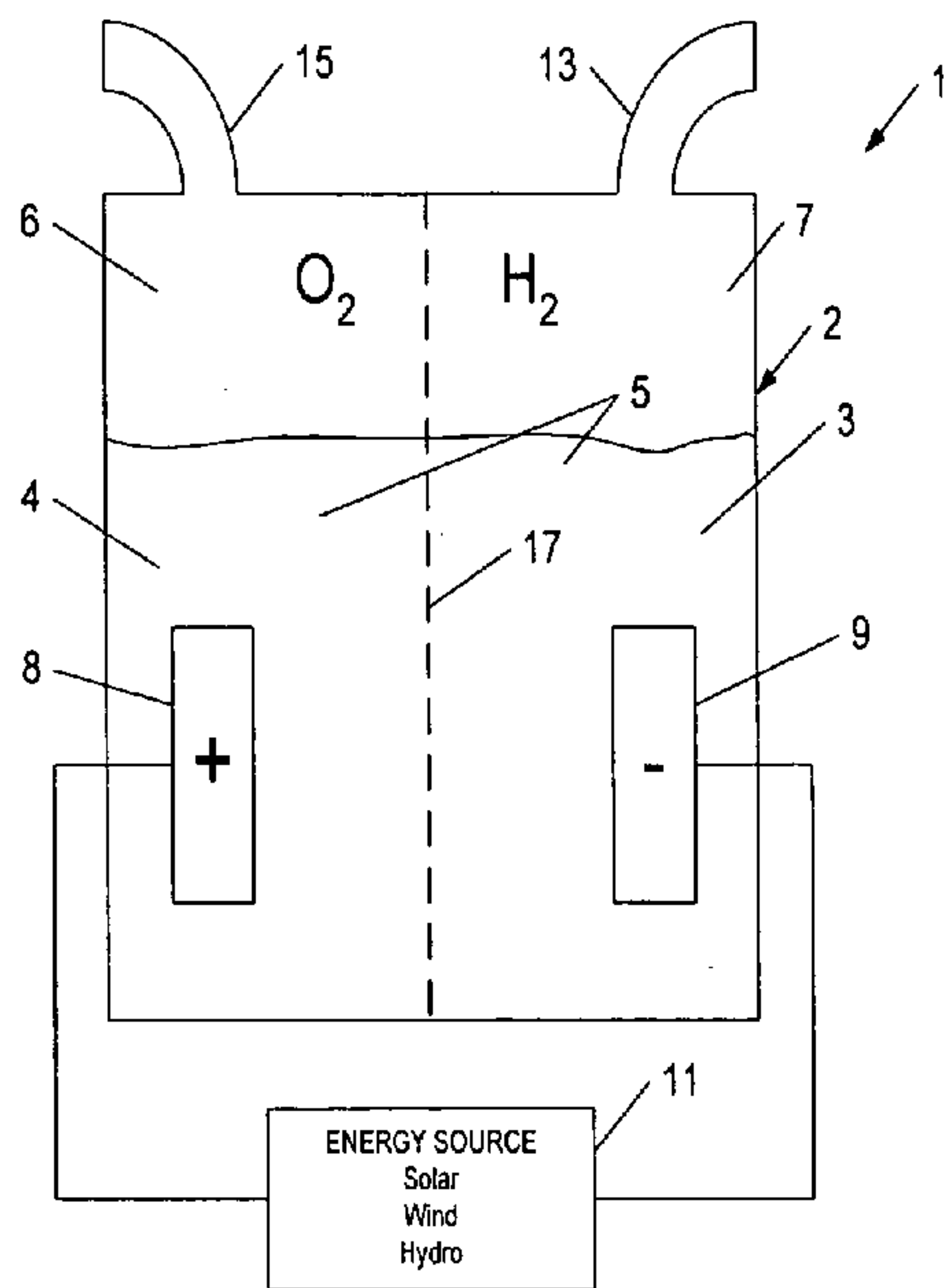

GENERATE ELECTRIC CURRENT

APPLY CURRENT TO ELECTRODES

MEMBRANE FACILITATES ELECTROLYSIS

GENERATE HYDROGEN GAS

TRAP HYDROGEN

EXHAUST HYDROGEN GAS

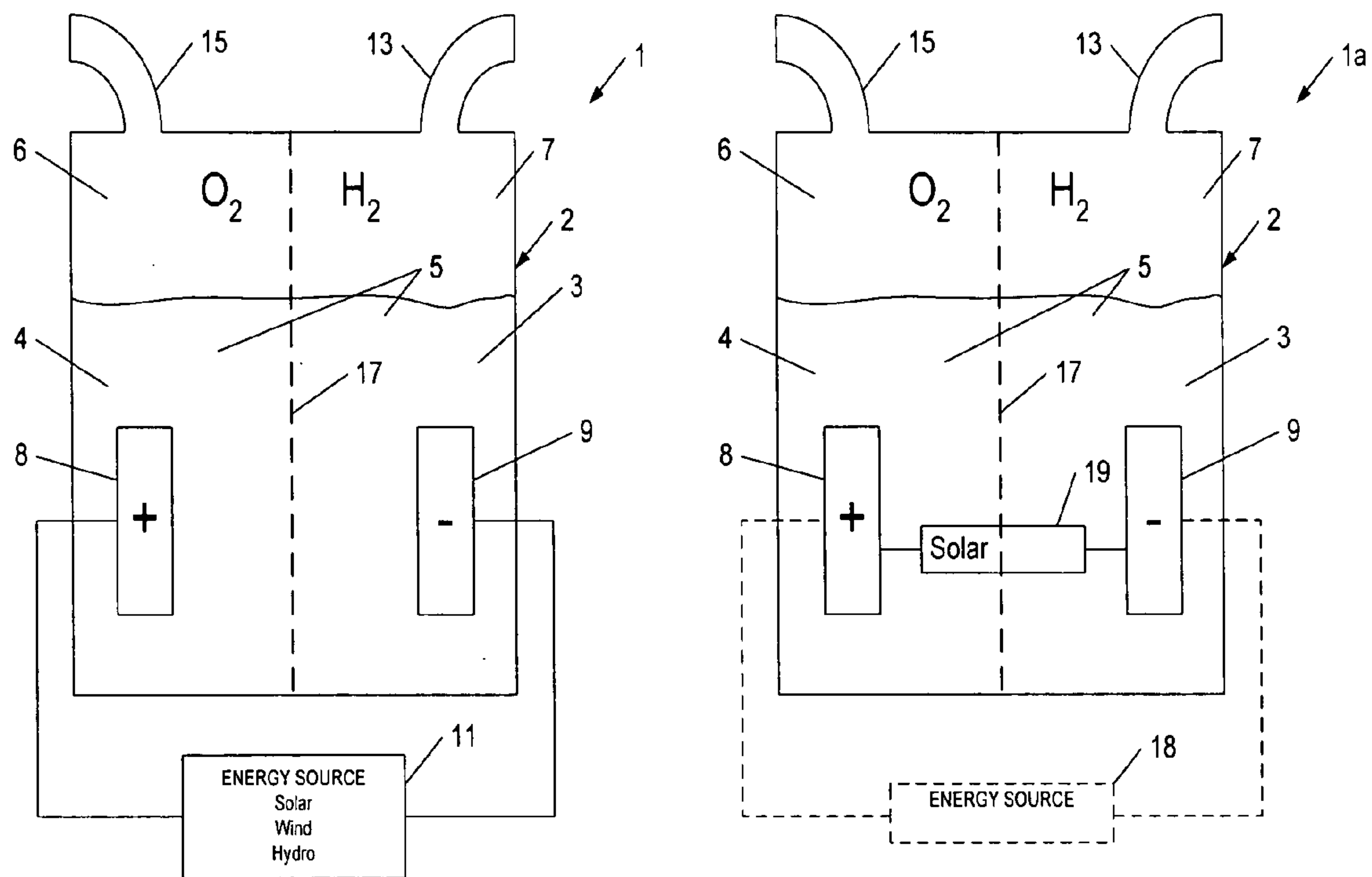

GENERATE ELECTRIC CURRENT
 APPLY CURRENT TO ELECTRODES
 MEMBRANE FACILITATES ELECTROLYSIS
 GENERATE HYDROGEN GAS
 TRAP HYDROGEN
 EXHAUST HYDROGEN GAS

FIG. 1

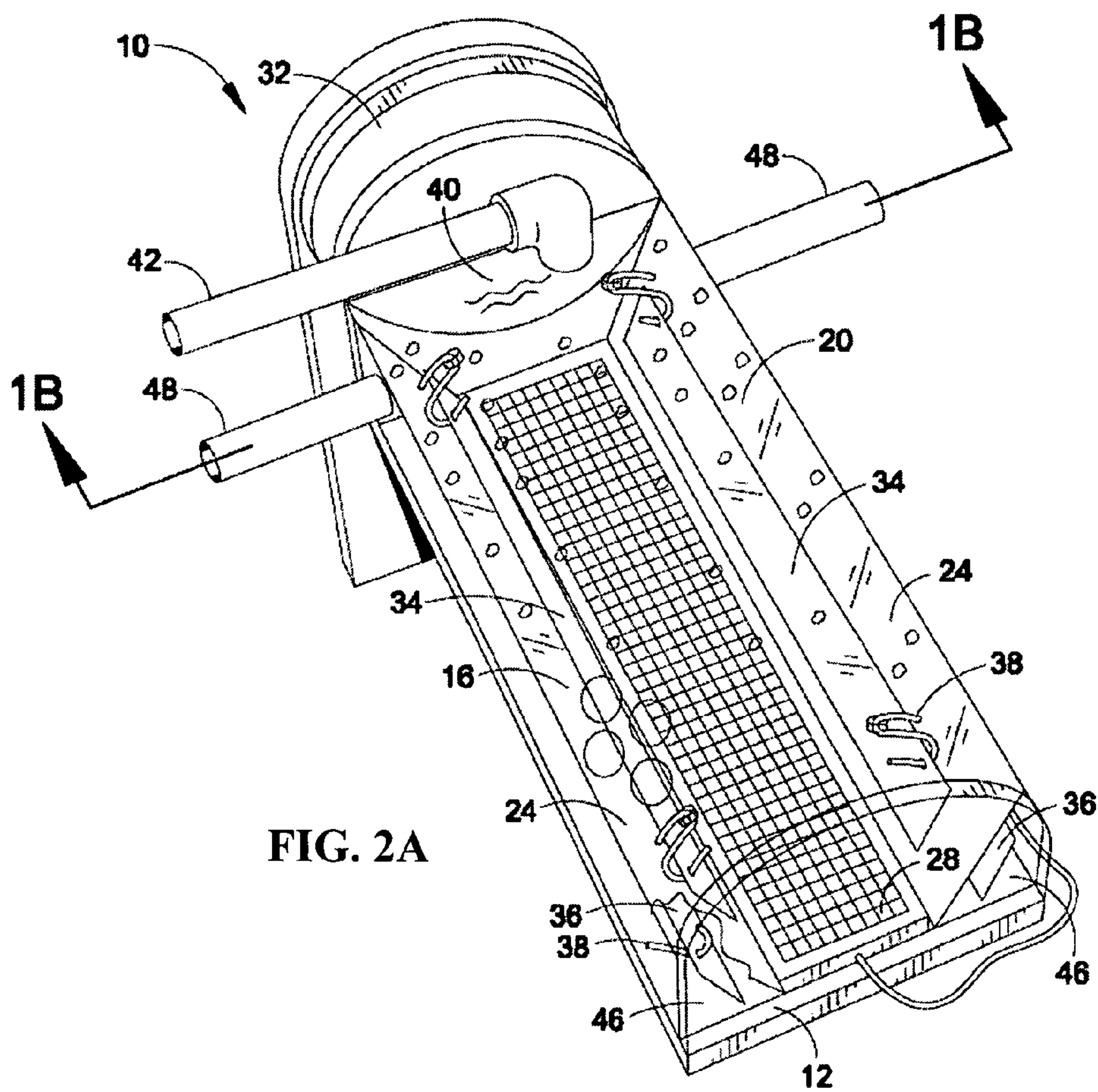

FIG. 2A

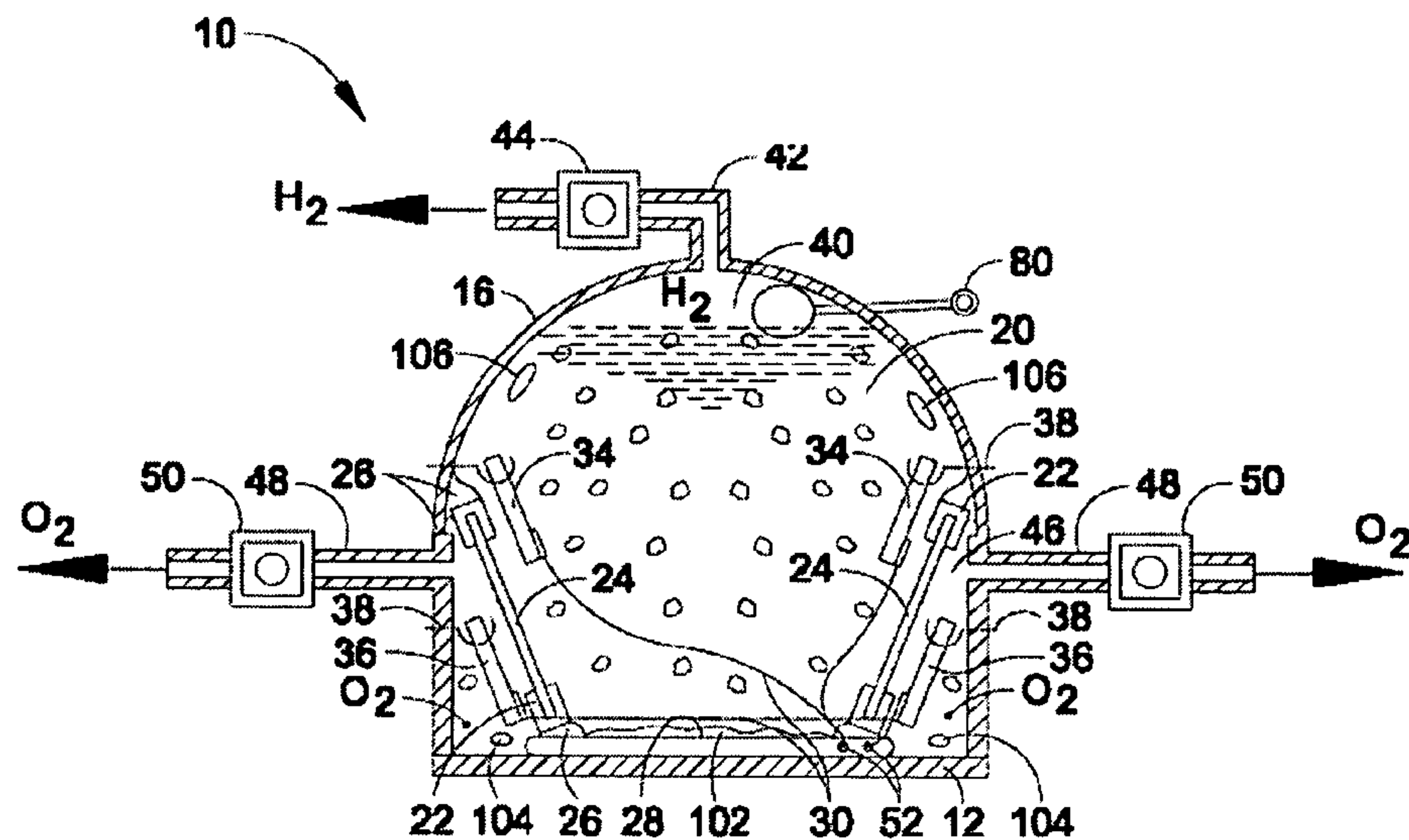

FIG. 2B

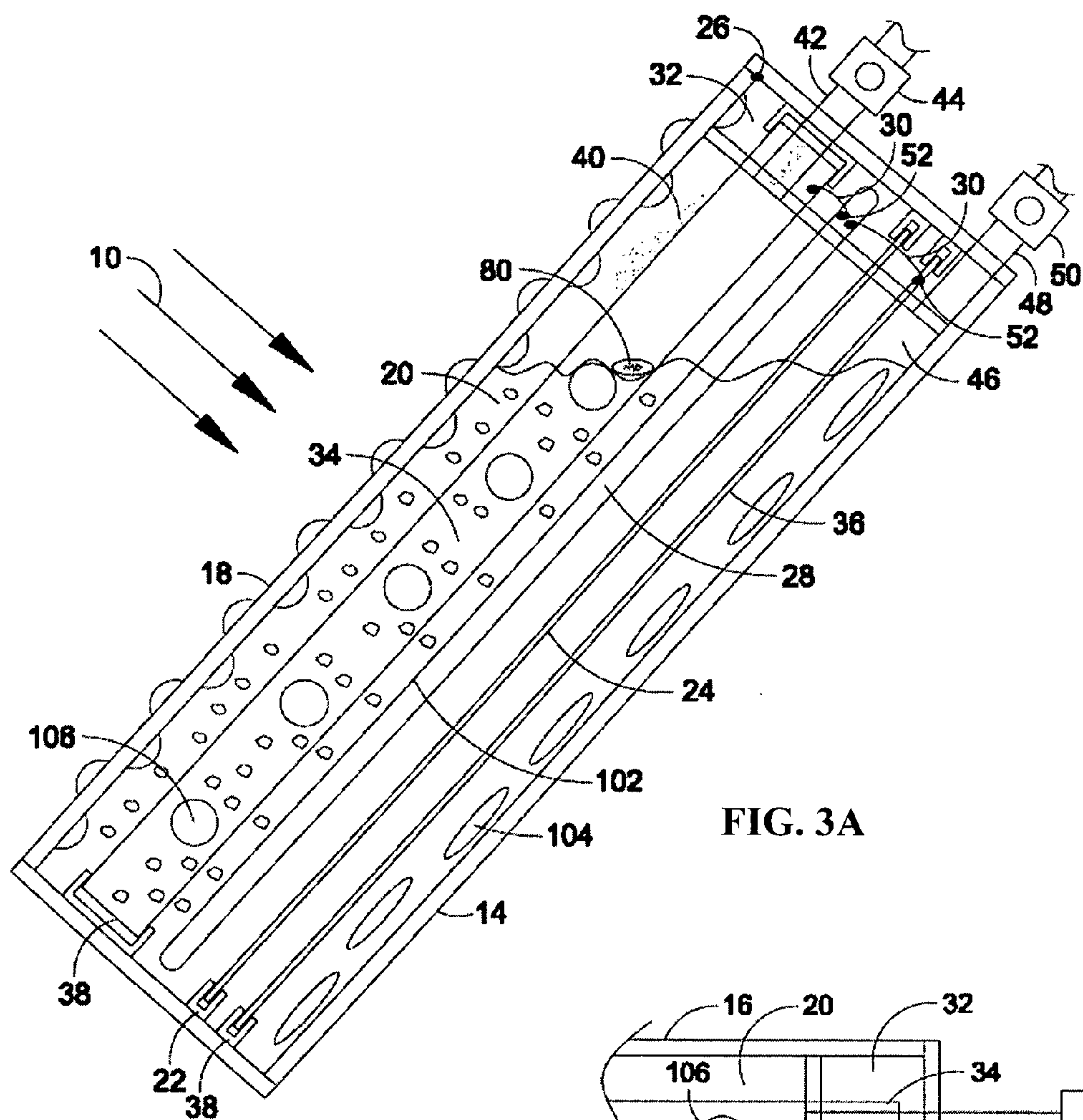

FIG. 3A

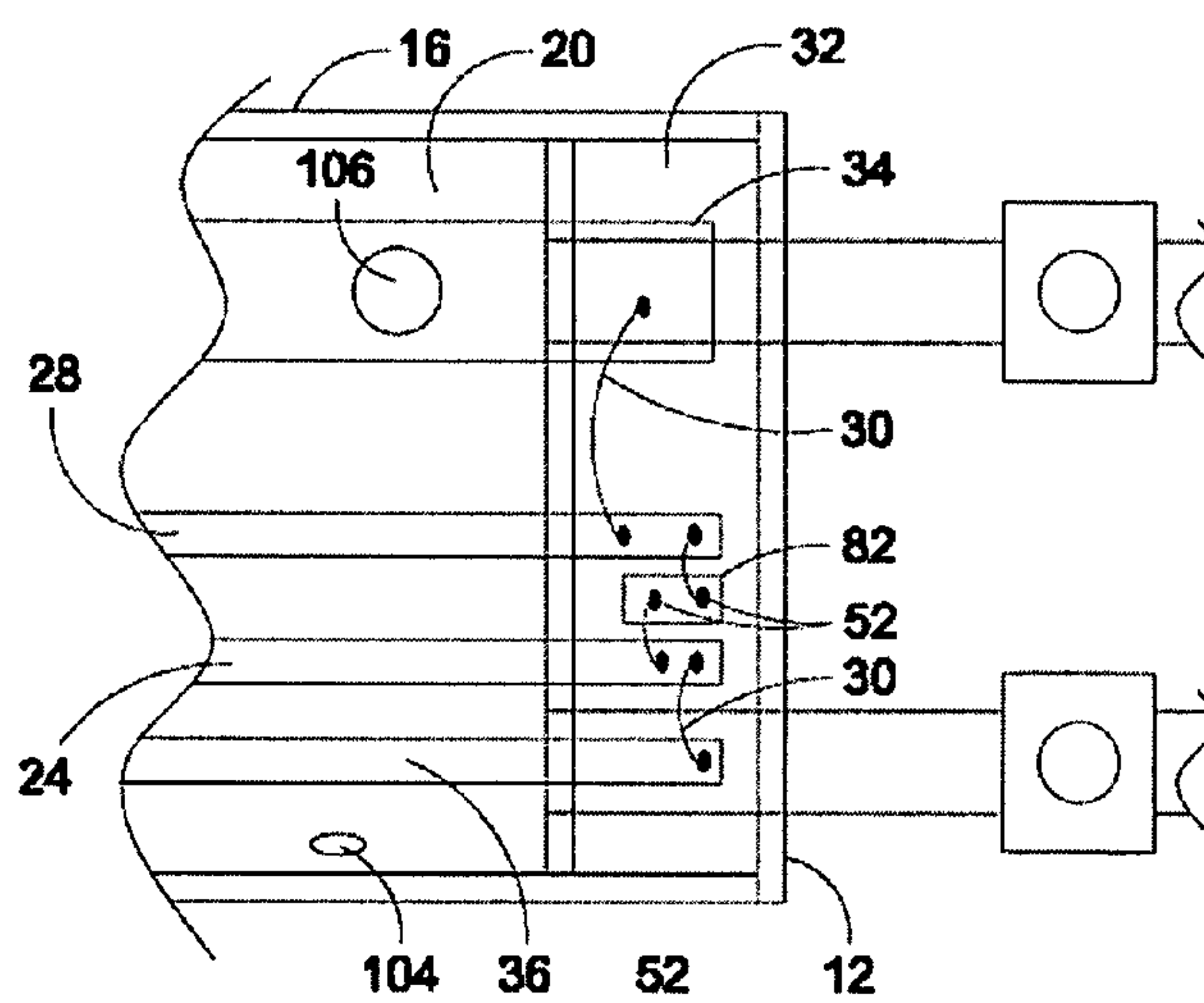

FIG. 3B

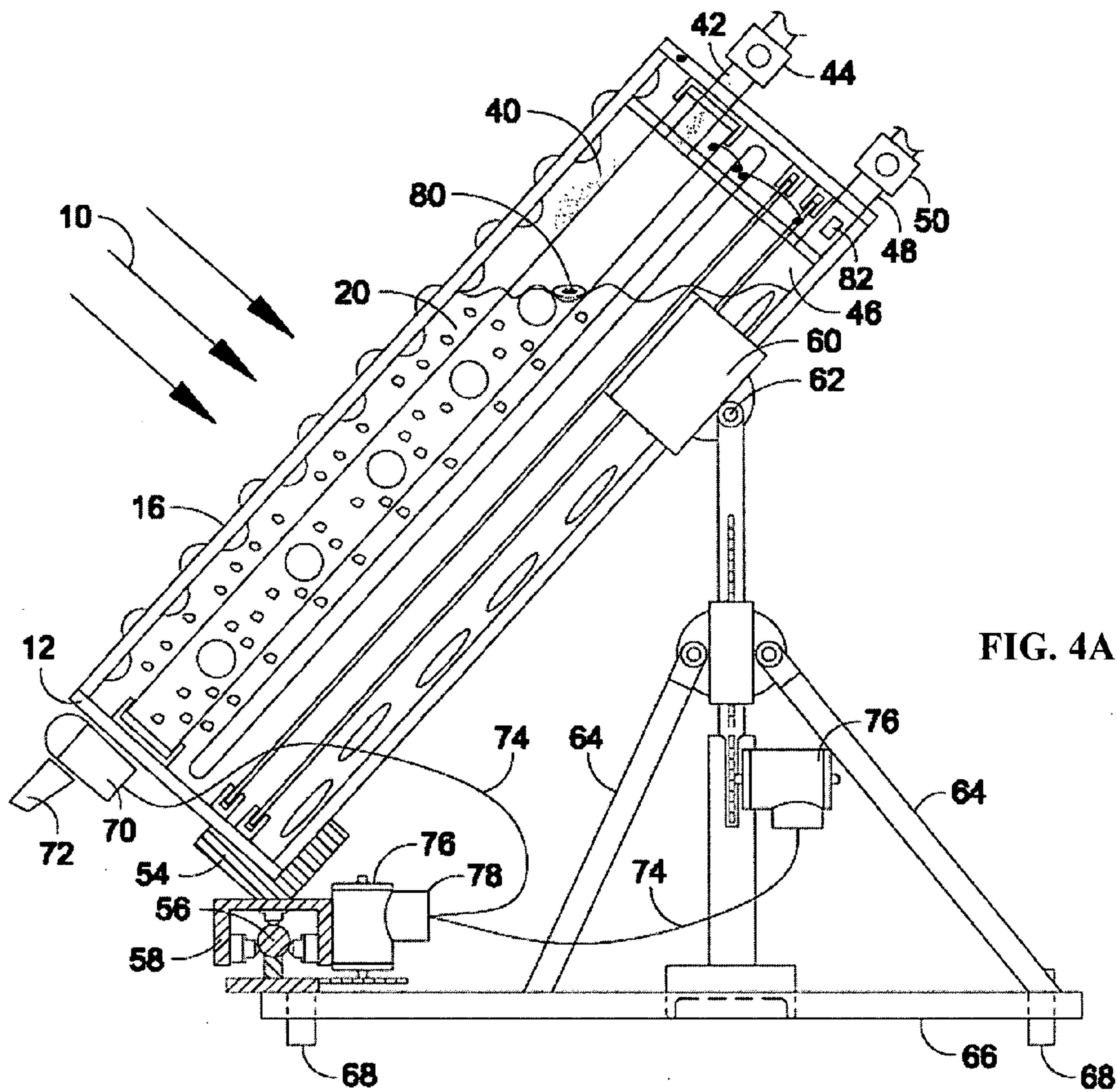
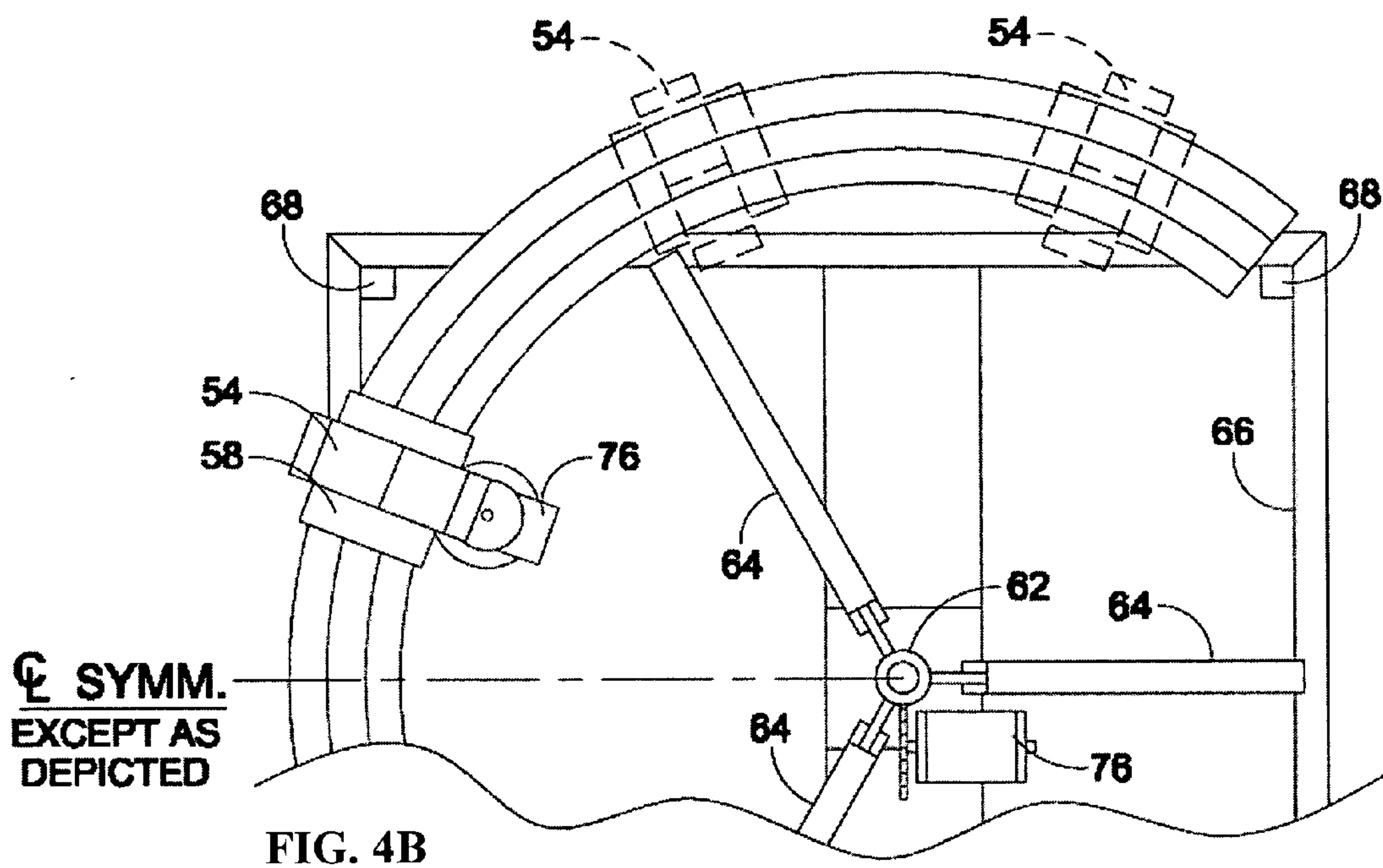
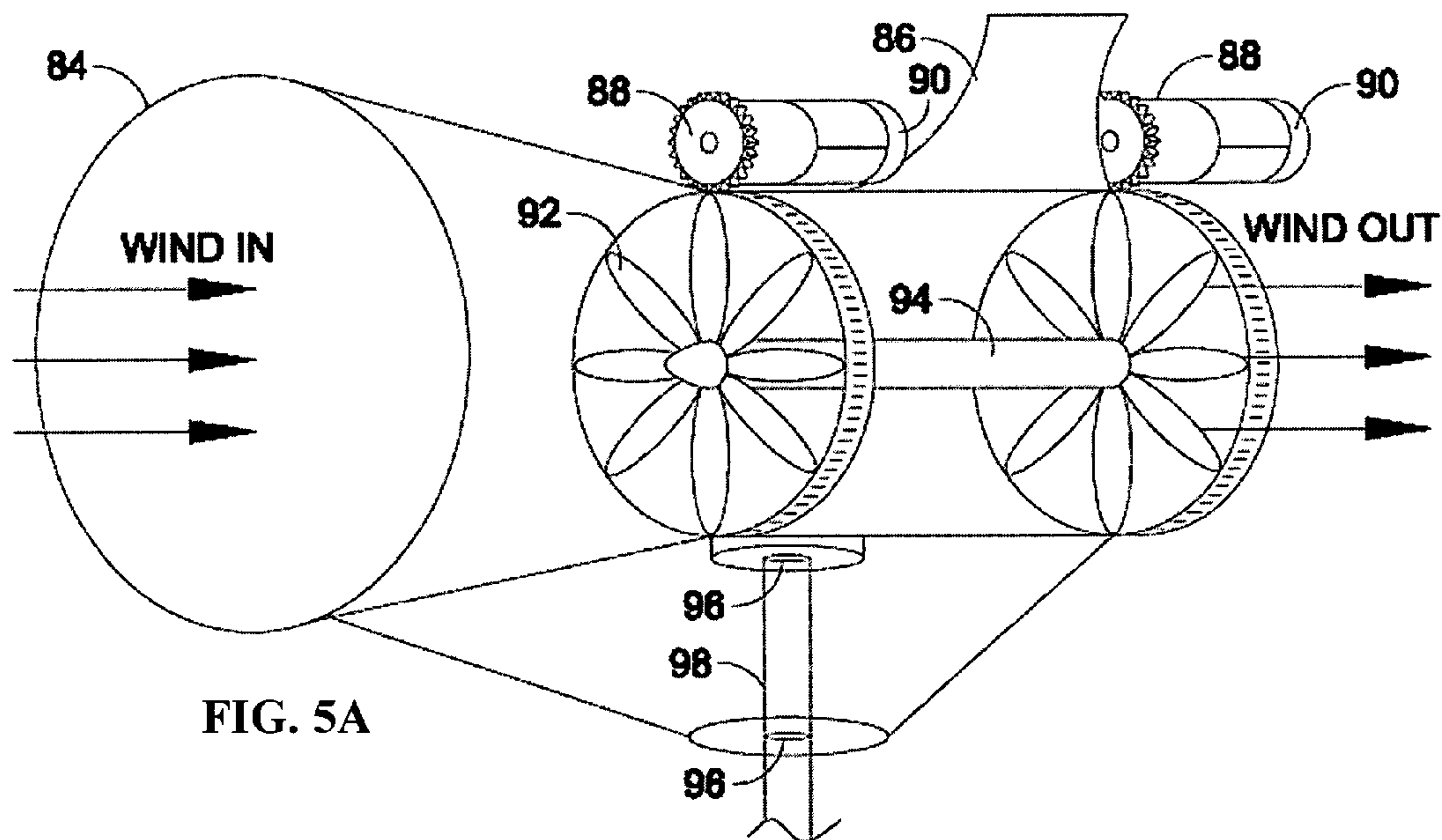

FIG. 4A



☞ SYMM.
EXCEPT AS
DEPICTED



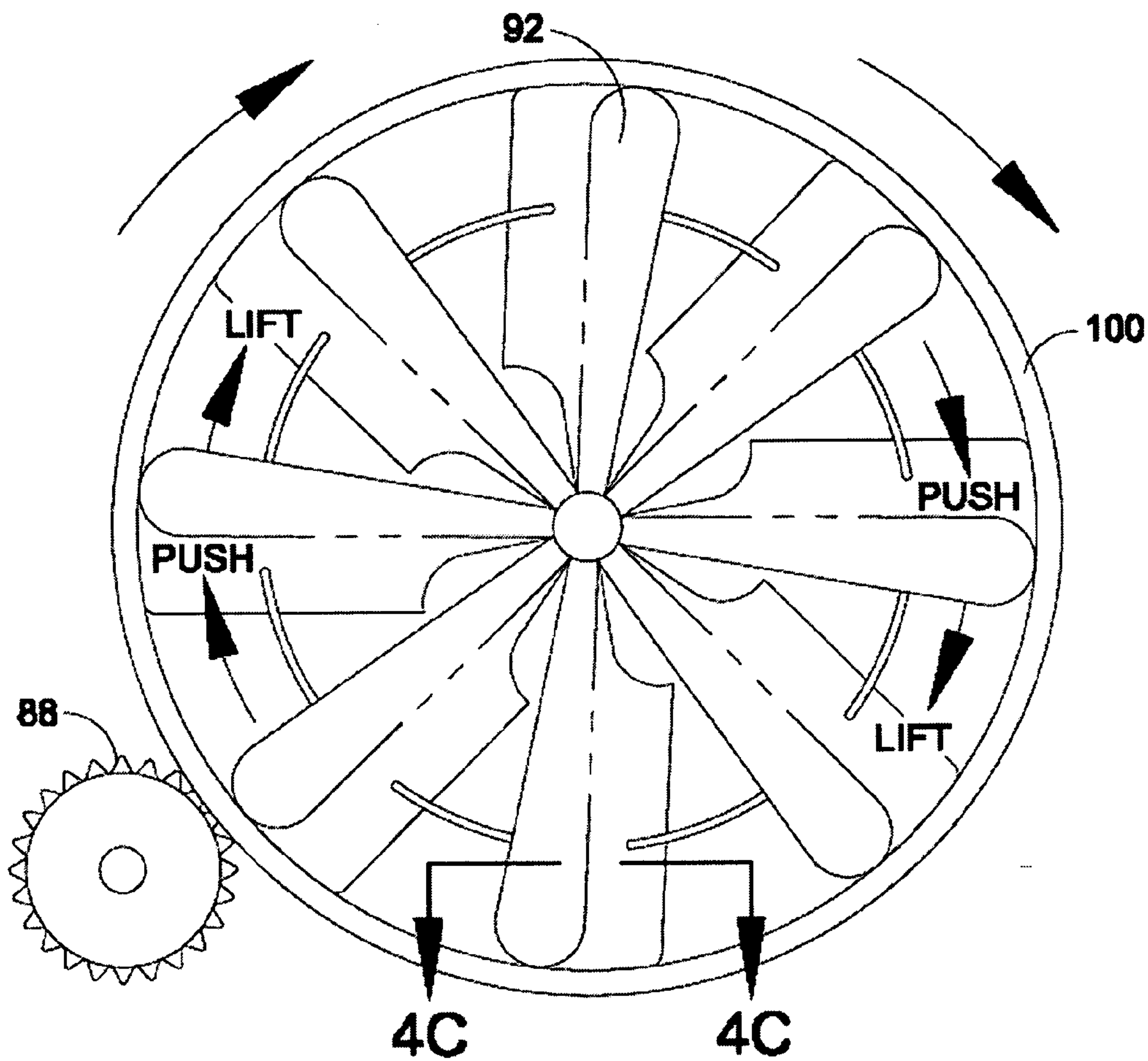

FIG. 5B

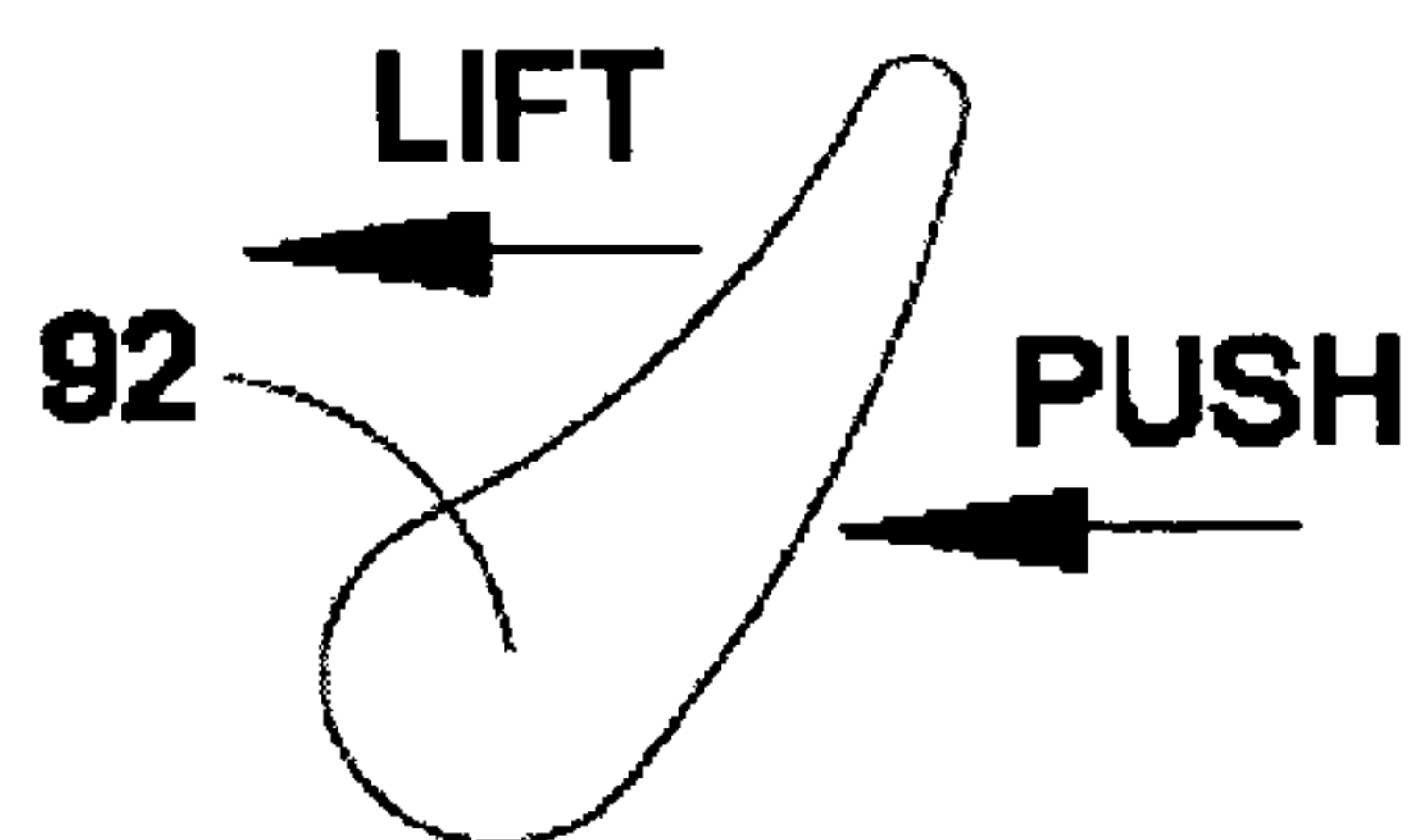

FIG. 5C

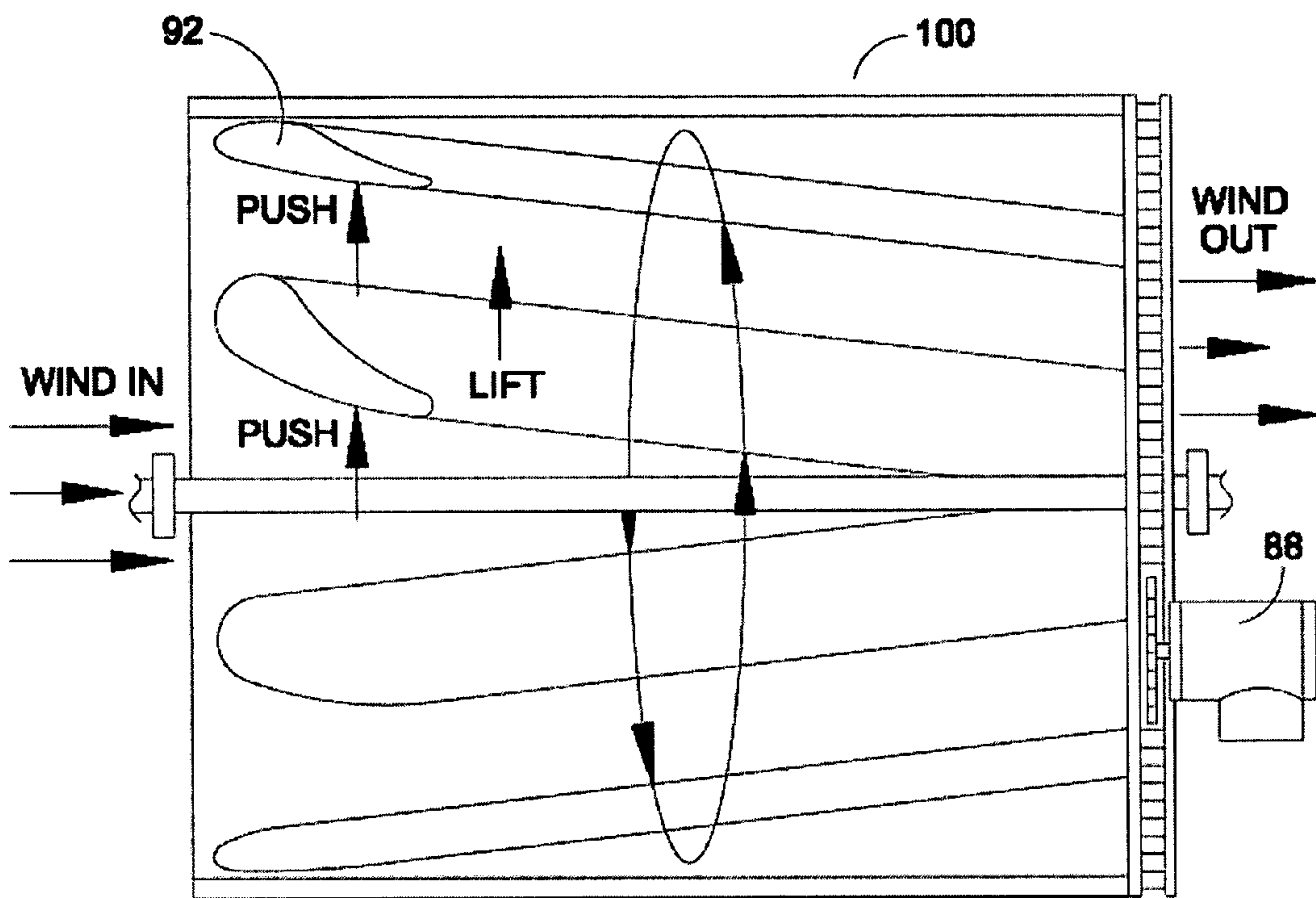

FIG. 5D

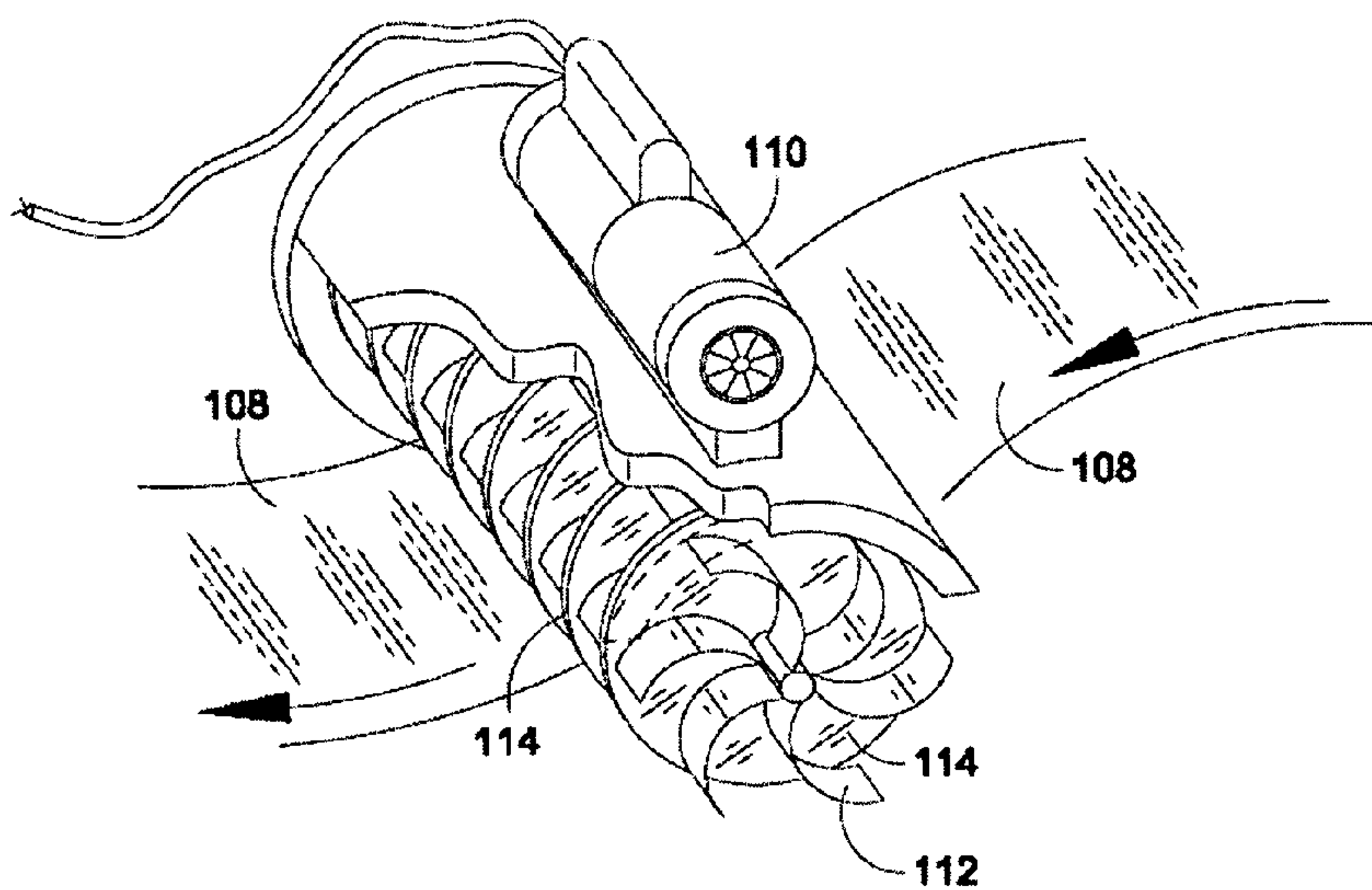

FIG. 6A

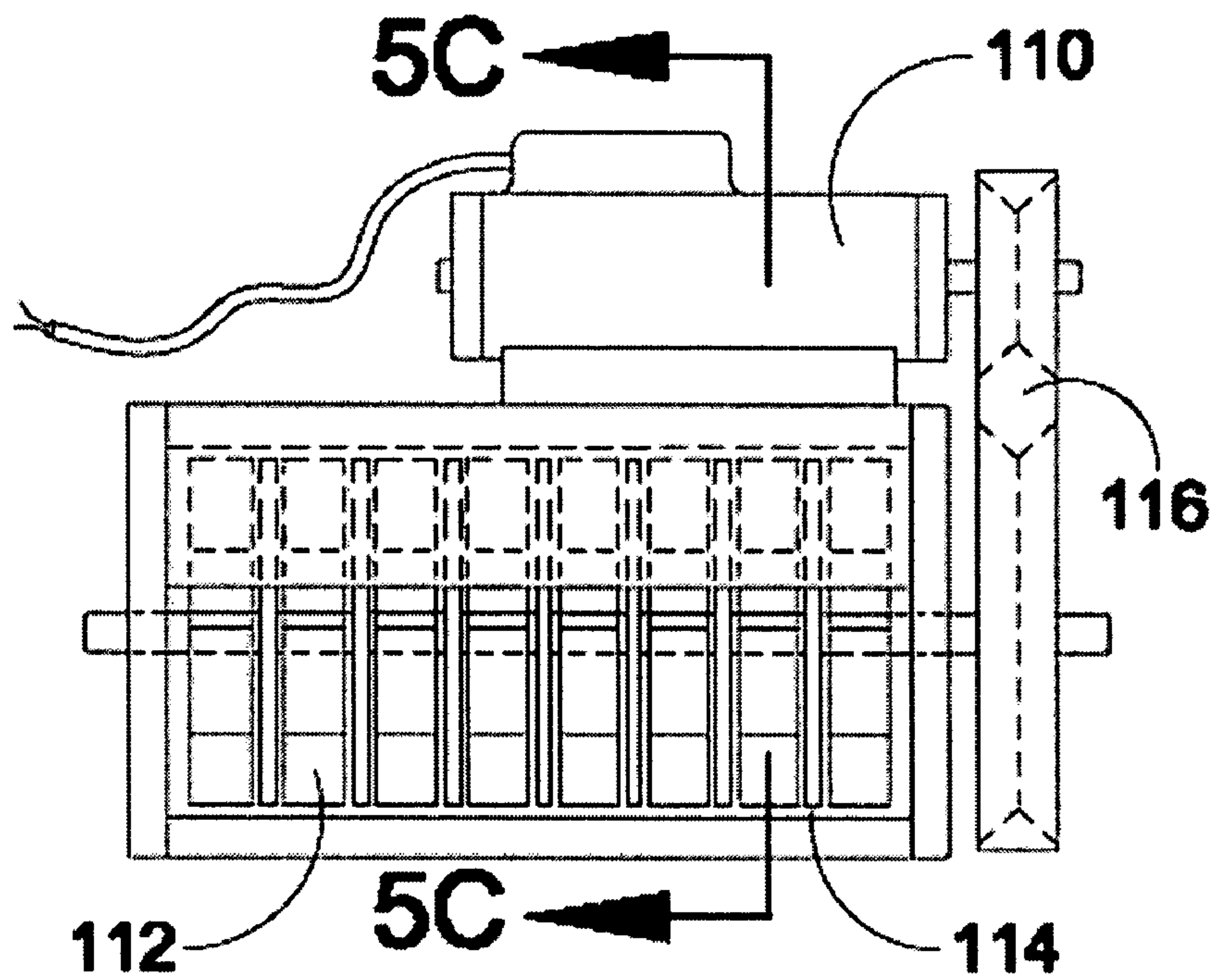

FIG. 6B

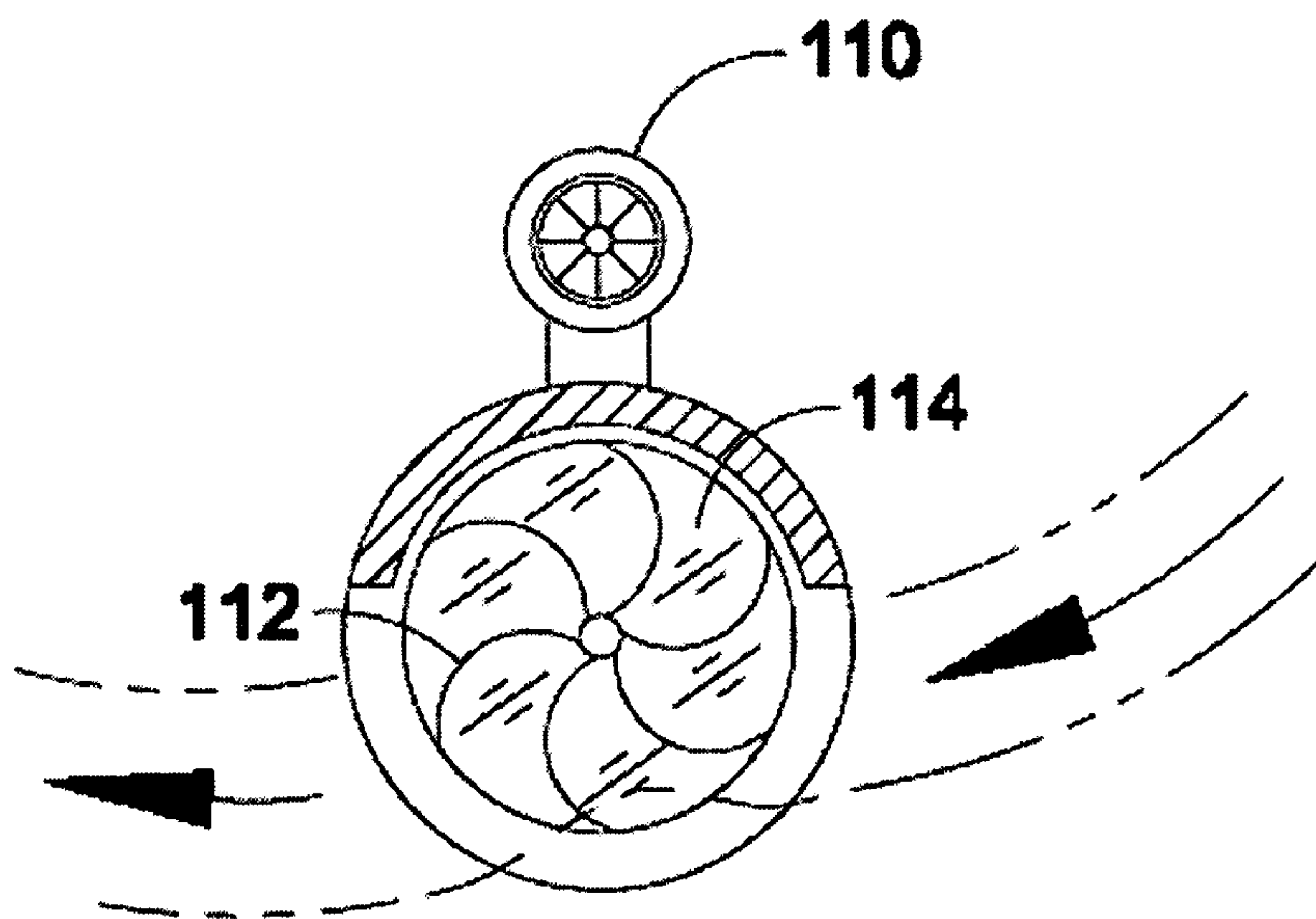

FIG. 6C

SYSTEM AND METHOD FOR GENERATING HYDROGEN GAS USING RENEWABLE ENERGY

BACKGROUND

[0001] This patent application refers to a Disclosure Document filed by the inventor and assigned number 529415 by the US Patent and Trademark Office.

[0002] The field of the present invention is hydrogen generation. More particularly, the present invention relates to the generation of a hydrogen gas using an electrolysis process.

[0003] Hydrogen production has been primarily carried out by large refineries using oil or natural gas as feed stock for using steam conversion. Some hydrogen manufacturing uses utility-produced electricity for causing an electrochemical reaction. Certain hydrogen producing approaches have proposed a solar assist with utility electricity, or solar-exposed opposing glass sheets with electrically conducting coatings. However, no practical way is known to generate hydrogen on-site for individual and commercial needs, exclusively by renewable energy sources, with no fossil fuel consumption or pollution.

[0004] In the prior art certain electrochemical systems have been used. One technique to create hydrogen uses utility grid electricity with a photo assist. Others use photovoltaic sources wired to a separate electrolyzer. The major hydrogen production methods used today are based on reforming natural gas using steam. This requires high temperatures, utility electricity, and considerable fossil fuel energy consumption. Hydrogen may be produced in a large refinery in a process similar to gasoline production from crude oil. Burning coal is also used to produce hydrogen, usually through the steam process. Each of these processes is dependent upon natural resources that have limited supplies and yield pollutants into the earth's environment, especially the air.

[0005] One means of hydrogen production began in Switzerland by Michael Gratzel, at the Laboratory of Phototonics and Interfaces at EPEL, Switzerland. This method employs the use of two catalyzed glass surfaces so hydrogen is produced on one surface and oxygen on the other as solar energy passes through. The upper surface is transparent, and may be coated with platinum particles to produce hydrogen. The lower surface evolves oxygen. This process is feasible but it works at a 3% or lower efficiency rate, which is an unacceptable efficiency rate at this time. This system has not been commercially utilized because of coating system inefficiencies and lack of equipment production techniques.

[0006] Certain procedures have used photoelectro means. For example, U.S. Pat. No. 6,471,834 to Roe et al. (2002) discloses an apparatus and method of performing electrolysis electrically. It separates the electrolyte into its chemical components. This design functions using direct current (DC) electricity using cathodes in conjunction with incident light energy to increase efficiency. A copper photo collector/cathode is coated with a thin layer of metal, preferably nickel, by electroplating deposition. During the electrolysis process the cathode is irradiated with light. This reduces the amount of DC electrical energy necessary to separate a given quantity of electrolytic material. This approach also requires electroplating or vapor deposition of a metal, preferably

nickel, onto a conductive surface, such as a sheet of copper, which becomes near black and serves both to collect and absorb the light and simultaneously acts as a general surface. Such black surfaces will increase heat in the unit, which heat must likely be reduced. This system appears to be unsuited for residential or commercial production of hydrogen gas.

[0007] U.S. Pat. No. 6,409,893 to Holzbock (2002) proposes a work electrode and a counter electrode arrangement. One electrode has an electrochemically active surface facing the other electrode. The second electrode's surface is catalytically active. The catalytically active surface of the counter electrode contains at least one polymer and/or at least some salt of polymer doped in an electrically conductive polymer electrolyte system. This approach focuses on developing special electrodes. This design generally uses heavy, thick electrodes to allow the flow of sufficient current. Since the catalytic activity of carbon is low, it should have a large surface and be catalytically activated. Employing platinum as the catalytically active substance is economically disadvantageous. The system also uses iodine. Iodine has a very slow reaction rate, and shortens the life of the cell because of iodine's reaction with platinum. The loss of this platinum makes the system economically disadvantageous.

[0008] U.S. Pat. No. 4,011,149 to Nozik (1977) proposes the use of a thin film where electrodes are deposited on either side of a thin solid polymer electrolyte sheet to make photoelectrolysis of water by solar radiation. This system is similar to Roe's above. Several devices are outlined which essentially employ the electrical conductor thin film layer as the electrode with a counter electrode to complete the circuit. The Nozik process for producing hydrogen from solar radiation comprises the exposure of one electrode to solar radiation. The counter-electrode is in contact with the chemically inert thin film semi-conducting layer. This layer is supported on at least one inner thin film layer that applies a bias between the electrode and the counter electrode to collect hydrogen. The thin electrodes are likely difficult and expensive to manufacture, especially when planning for large markets outside of laboratory work.

[0009] U.S. Pat. No. 6,395,252 to Getty et al. (2002) shows a very different method of making hydrogen. This method comprises the reaction of a metal catalyst in a degassed aqueous organic acid solution within a reaction vessel under anaerobic conditions requiring constant temperature and specific pH. This method requires a continuous supply of degassed aqueous organic acid solution as an example of competing hydrogen production techniques. This process has received some academic attention but little has been done to commercialize this process.

[0010] U.S. Pat. No. 6,544,400 to Hockaday et al. (2002) shows a system for delivering hydrogen by a controlled fuel stream to applications using wicking to control the contact to create a feedback mechanism. This requires a highly controlled monitoring of the process and does not appear to be designed for production of adequate quantities of hydrogen production necessary for commercial applications.

[0011] The main disadvantage of the above prior solar-to-hydrogen conversion systems is that they do not make hydrogen directly, but require a separate electrolyzer. Separate electrolyzer systems can consume as much as 38% to 40% of the electricity put in; thus industry style electrolyzers

are currently only approximately 60% efficient, and typically rely on grid electricity. A distinct disadvantage is that utility grid electricity generally consumes natural gas, oil, or coal with the resultant air and environmental pollutions associated with the use of these limited natural resources.

[0012] In prior-art systems poor coatings on substrates have led to further problems. Some photoelectrochemical processes use flat glass sheets with a thin catalytic coating to attract solar energy to make electrical current. These experimental coating systems have not been proven effective over time nor have they been developed to full usefulness at this time. It has proven difficult to apply the catalytic coatings to semiconductor surfaces. The glass in this process is heavy and it has been shown that there is difficulty joining the edges to maintain adhesion of the several sheets.

[0013] The problems of previous efforts of producing hydrogen include high capital expenditures, fossil fuel consumption, pollution, low production, low efficiency, non-durable equipment, long distance energy transmission, and they do not make distributed energy on-site. Accordingly, there exists a need for an efficient, scalable system for generating hydrogen gas.

SUMMARY

[0014] Briefly, the present invention provides a system and method for generating hydrogen gas. The system uses a vessel for holding an electrolyte solution. A membrane is arranged in the vessel to form a chamber, and a cathode electrode is positioned in the chamber and in the electrolyte solution. An electric current is applied to the cathode, and with a cooperating anode, produces hydrogen gas using an electrolysis process. The membrane traps or confines the hydrogen in an open area of the chamber, and assists in keeping the hydrogen separate from oxygen or other gasses. The hydrogen gas is exhausted from the chamber for further processing, storage, or use.

[0015] In a preferred example, the hydrogen generation system has a transparent cover and has a photovoltaic panel in the vessel. The photovoltaic panel generates the electricity for powering the electrolysis process. The photovoltaic panel may be submerged in the electrolyte solution, which acts to concentrate light rays onto the panel. Other structures, such as the cover, may be configured to further concentrate light rays onto the panel. In some examples, oxygen gas may also be collected, stored, and used. The generation system may also use an external electricity source for powering the electrolysis process when insufficient electricity is produced by the internal photovoltaic cell. The external power is preferably a renewable source, such as solar, wind, or hydro.

[0016] Advantageously, the hydrogen generation system may be configured to generate hydrogen gas using only renewable sources of energy. Further, the generation system is deployable in a contained vessel, and provides a simple membrane structure for keeping the hydrogen gas separated from the oxygen and from other contaminants.

BRIEF DESCRIPTION OF THE DRAWINGS

[0017] FIG. 1 is a diagram of hydrogen generation system and method in accordance with the present invention;

[0018] FIG. 2 is a perspective view and an end view of a hydrogen generation system in accordance with the present invention;

[0019] FIG. 3 is a plan view and an enlarged partial view of a hydrogen generation system in accordance with the present invention;

[0020] FIG. 4 is a side view and enlarged partial view of a tracking system for a hydrogen generation system in accordance with the present invention;

[0021] FIG. 5 shows four views of a wind turbine in accordance with the present invention; and

[0022] FIG. 6 shows three views of a water/hydro turbine in accordance with the present invention.

DETAILED DESCRIPTION

[0023] Referring now to FIG. 1, a system for generating hydrogen gas is shown. Generation system 1 includes a vessel 2 which holds an electrolyte solution 5. The electrolyte solution 5 may be a mixture of water and an electrolyte, such as an acid or polymeric electrolyte. It will be appreciated that other electrolyte solutions may be used consistent with this disclosure. The vessel has a membrane 17 which is arranged to form a hydrogen chamber 3. A volume space 7 above the electrolyte 5 level enables collection of hydrogen gas. An oxygen chamber 4 may also be formed, and has an associated volume space 6 for collecting oxygen gas.

[0024] Two electrodes are placed in the electrolyte solution 5. A cathode 9 is positioned in the hydrogen chamber 3, and an anode 8 is positioned in the oxygen chamber 4. An electric source 11 is coupled to the cathode 9 and the anode 8, which causes an electrolysis process. More particularly, the electrolysis process splits water molecules into its elements, with hydrogen gas forming at the cathode 9, and oxygen gas forming at the anode 8. The respective gases bubble through the electrolyte solution 5, and the hydrogen gas collects in the hydrogen volume 7, while the oxygen gas collects in the oxygen volume 6. A hydrogen outlet 13 is used to exhaust hydrogen gas, and an oxygen outlet 15 is used to exhaust oxygen gas.

[0025] The membrane 17 is selected to restrict the passage of the hydrogen gas. In this way, the membrane acts to trap or confine hydrogen gas in the hydrogen collection volume 7. The membrane may also restrict the passage of oxygen, and thereby keeps the hydrogen gas from mixing with oxygen in the oxygen collection volume 6. The membrane may also be selected to facilitate the electrolysis process. For example, the membrane 17 may be a proton-exchange membrane that allows protons to pass during the electrolysis process. It will be appreciated that the composition, characteristics, and dimensions of the membrane may be selected according to specific electrolysis requirements.

[0026] Advantageously, the generation system 1 provides sufficiently pure hydrogen gas without complex gas separation equipment. Instead, the generation system 1 uses a simple membrane to keep the hydrogen separated from other gases, which enables the efficient collection of commercial grade hydrogen gas using known gas-processing techniques. It will be understood that further purifying and processing of the hydrogen gas may be desirable for some uses. Also, the energy source 11 is preferably a renewable electricity source, such as a photovoltaic cell, wind turbine, or hydro turbine, so the generation system 1 is environmentally friendly, and may be used to generate hydrogen in a wide variety of locations.

[0027] Generation system 1 uses electric energy that is generated by an energy source 11 that is outside the vessel 2. For example, the energy source may be photovoltaic cells, a wind turbine, or a hydro turbine placed a distance from the vessel. It will be appreciated that these energy sources may be used individually, or may be used in any combination. It will also be understood that the energy source may include electricity from a commercially available power grid or generator. In another example, a hydrogen generator 1a uses an energy source which is internal to the vessel 2. More particularly, the energy source is a photovoltaic cell or panel 19 connected to the cathode 9 and the anode 8. The vessel 2 includes a transparent portion for allowing light rays to project onto the photovoltaic cell 19. It will be understood that cells may be arranged to form a photovoltaic panel if additional surface area is desirable. The light causes the photovoltaic cell to generate electricity, which drives an electrolysis process to generate hydrogen gas. Although the photovoltaic panel 19 is shown in the electrolyte solution, it will be appreciated that its position also may be otherwise selected according to lighting patterns.

[0028] Generation system 1a may optionally connect to an external energy source 18. The energy source 18 may be, for example, the commercial power grid or generator, a solar array, a wind turbine, or a hydro turbine. The energy source 18 may also include switching controls (not shown) for selectively coupling the energy source to the anode 8 and the cathode 9. For example, the switching controls may be set to preferably allow the internal solar panel to provide power, but may switch to a wind turbine during periods of insufficient light.

[0029] Significantly, generation system 1a provides a single vessel 2 for producing commercial grade hydrogen. An internal solar panel 19 generates electricity that drives an electrolysis process, while a membrane 17 traps the hydrogen gas and keeps it separate from the oxygen and sufficiently pure. Hydrogen gas may be exhausted into known containment or transport structures for storage or use. For example, the generation system 1a could include a hydrogen storage tank for collecting hydrogen gas. The hydrogen may be piped to a fuel-cell where the hydrogen gas is converted into electricity as needed. In this way, the generation system 1a enables the generation and storage of energy from renewable sources, such as solar, hydro, and wind, when those sources are available. At other times, for example when it is dark and there is no wind, the fuel cell uses the stored hydrogen energy to produce electricity.

[0030] In use, as shown in the flowchart of FIG. 1, the hydrogen generation process first generates an electric current. The electricity may be produced, for example, by a solar panel in the same vessel where the hydrogen will be produced. More particularly, the solar panel may even be placed in the electrolyte solution, and the electrolyte solution may advantageously concentrate light rays onto the solar panel. Alternatively, the electricity may be generated external to the vessel by a solar panel, wind turbine, hydro turbine, or traditional commercial generation.

[0031] Anode and cathode electrodes are separated by a membrane 17, which is preferably a proton-passing membrane. By adjusting the characteristics or dimensions of the membrane, the electrolysis process may be moderated or otherwise controlled. The generated electricity is applied to

the anode and cathode electrodes in the electrolyte solution, which causes hydrogen to be produced at the cathode electrode and oxygen to be produced at the anode. The hydrogen gas bubbles through the electrolyte solution and is trapped by the membrane in a hydrogen collection volume, and the oxygen may bubble through the electrolyte and be trapped by the membrane in an oxygen collection volume. Since the membrane may be selected to restrict passage of both hydrogen and oxygen, the membrane keeps the generated hydrogen and oxygen from mixing. Preferably, the same membrane is used for controlling the electrolysis process and for trapping the hydrogen gas, although separate membranes may be used.

[0032] The hydrogen may then be exhausted for further processing, storage, or use. In a similar manner, the oxygen may be exhausted as waste, or collected for processing, storage, or use. Although the system and process is described for generating hydrogen gas, other electrolytes and membranes may be selected for the production of other gases.

[0033] The generation system applies electrical energy, preferably from a renewable source, into a vessel or case for photoelectrochemical hydrogen production. There is no separate electrolyzer as in known systems. This solar direct electrochemical process uses solar exposure on immersed photovoltaic cells to power anodes and cathodes in the electrolyte to produce the fuel gas, hydrogen. By eliminating the traditional electrolyzer, the overall cost to produce hydrogen is reduced as electrolyzers are expensive and can reduce efficiency by consuming as much as 40% of the available electricity. In the present process, the original high capital cost of the electrolyzer is eliminated. The primary concentrating process is a combination of aqueous electrolyte solution and lenses that provide solar concentration. Also the vessel or case may receive electricity from wind turbine or hydro turbines to augment the solar power.

[0034] The disclosed generation system uses an electrolysis process to generate hydrogen from an electrolyte solution. In an electrolyte-water solution the hydrogen ions have a positive (+) charge and these become attracted to the negative (-) cathode to produce hydrogen. The oxygen ions have a negative (-) charge and they become attracted to the positive (+) anode to produce oxygen. The hydrogen ions are attracted to the negative electrode where they receive electrons, become stressed by over loading and combine to form the hydrogen molecule. Likewise, the negative oxygen ions migrate toward the positive terminal in the electrolyte to give up an electron and combine to form the oxygen molecules. Electro catalysts such as platinum may be used as an electrode or a coating on an electrode to reduce the amount of energy needed to break apart and oxidize hydrogen gas.

[0035] In the hydrogen generation system, as the splitting of the water takes place, hydrogen and oxygen are produced on separate sides of the membrane and collected in separate containers or chambers. Thus, the gases are respectively channeled from the high concentration pressure in the electrolyte toward two separate low pressure reservoirs for hydrogen and oxygen. These gasses are then processed and transferred to storage tanks.

[0036] With the hydrogen and oxygen molecules cleanly separated and stored, their potential energy exists for future

use. Employing fuel cells, hydrogen and oxygen may be recombined to generate clean electrical energy that is free of fossil fuel and pollution. Such fuel cell produced energy is used as electricity for homes, business, industry, as well as to power automobiles and trucks. Hydrogen may also be used in industry as fuel for combustion purposes that yields no pollution or residue.

[0037] Accordingly, the direct photoelectrochemical process combined with wind and hydro turbine energy can be used to produce hydrogen while requiring no fossil fuel such as natural gas, oil, or coal. This technology is an improvement compared to prior art and other current efforts to use just solar to make hydrogen. This present hydrogen generation process is an improvement over systems that rely on metal or glass coated plates, some of which focus only on solar assist rather than direct solar electrochemical reaction. Some systems reformulate natural gas using steam to extract hydrogen from natural gas, oil, or coal. The consumption of such fossil fuels depletes the store of such natural resources in the earth and in making hydrogen, yields environmental pollutants. This pollution negatively affects humans and the earth environment everywhere.

[0038] In addition, the present process produces hydrogen energy on-site for local energy needs. The requirement for traditional distribution equipment, related pollution, and the associated costs are eliminated. For example, hydrogen may be used in fuel cells for electrical generation for residential use or for automobile and truck energy. The proposed hydrogen production process is accomplished on-site, at a residence or business, government, or military defense facility and at any location where power is required, and without consuming any utility grid electricity. Although it may use only renewable solar, wind, and hydroelectric sources of energy, if needed, it can consume utility grid electricity for producing hydrogen. Furthermore, the present electrochemical hydrogen generator has the additional advantages in that it eliminates the traditional electrolyzer used to make hydrogen with electricity, thereby eliminating the 40% inefficiency in the operation of the electrolyzer.

[0039] The disclosed generation system is also scalable. It is easily mass produced and arranged in multiple units, thus reducing the overall cost to the consumer.

[0040] FIG. 2A and FIG. 2B show a perspective and an end view, respectively, of an example hydrogen generator according to the invention. The generator has a case 12 that is approximately 152.4 mm thick by 741.2 mm wide by 1366.1 mm tall, although other dimensions may be used consistent with this disclosure. The case 12 may include transparent covers, such as transparent cover 16. The cover 16 may have a curve as illustrated in the drawing. Additional curves have been found to additionally improve the concentration of light rays. The curves may be in 6 inch half circles and therefore will require a number of these half circles to extend across the cover. The case 12 has a base of either molded polypropylene, ABS, or other plastic, although other material may be substituted. These materials are readily available from the plastic molding industry and can be molded by a number of technologies such as Resin Transfer Molding (RTM), injection molding, thermoforming, liquid molding, or other technology. The base is like a box with four sides and a bottom, all molded as one unit. The transparent cover 16 allows light to enter the case, and may

act to concentrate the light rays. The cover 16 may be made of molded acrylic, polycarbonate, or other product that can be molded by such methods as thermoforming, heat bending or other forming techniques that are also widely available.

[0041] The case cover 16 and bottom of case 12 are attached by slide-in compression connectors 26 at all junctures and sealed with adhesive. The case may be manufactured in various sizes, and may be arranged in a set of multiple units for additional generation capacity, depending on hydrogen production requirements. A float system 80 may be used for automated or semi-automated water and electrolyte replacement as needed during hydrogen production. Cooling-heat transfer chips 104 are available as needed to accommodate cooling or warming needs. Cooling-heat transfer chips 106 in the liquid electrolyte may also create a stirring or agitation of the electrolyte solution to enhance electrolysis. Suitable cooling-heat transfer chips can be obtained from Cool Chips, PLC, Gibraltar.

[0042] An aqueous electrolyte 20 fills the case cavity on both sides of the membrane 24. The electrolyte comprises water and sulfuric acid, for example. In one example the electrolyte is a 10% solution, but other concentrations may be used as needed to control production of hydrogen. Other electrolytes such as polymer composite types may also be employed. Another electrolyte which may be incorporated is a polymer material from Ballard, Burnaby, BC, Canada, which is capable of conducting an electric current in the presence of water, without acid. A preferred membrane 24 may be from 50 microns to 125 microns thick while various thicknesses may be chosen to alter yield of hydrogen and oxygen. This membrane is a product of DuPont Chemical Co of Fayetteville, N.C.

[0043] A frame 22 is constructed of high density polypropylene or ABS or other plastic, to hold the membrane. The frame is constructed by mating two plastic sections. The two sections are then pressed together with the membrane 24 secured between. Epoxy adhesive is used to hold the assemblage in place in the case. The case 12 parts are mated by press friction fit and bonded with epoxy 26. It will be appreciated that the membrane may be secured and attached using other methods and materials. Device 10 is shown with two membranes, each positioned to form an oxygen chamber 46. Since the device 10 generates a greater volume of hydrogen than oxygen, the hydrogen chamber 40 is larger than the oxygen chambers 46.

[0044] A photovoltaic cell 28 is located at the base of the case 12. In one example the cell is a US—64 made by ECD Uni-Solar, Auburn Hills, Mich. This photovoltaic cell has a triple-junction amorphous silicon alloy with a transparent weather resistant fluoropolymer ETFE elastomer covering. Optionally, for some operating conditions, a cell 28 may include a triple-junction silicon photovoltaic cell with up to 34 percent efficiency and can accept solar concentrations up to 400 suns. This latter photocell is manufactured by Spectrolab, Inc, Sylmar, Calif. Such silicon cells may have a clear coating 102, or a coating product, CARC—22, from Paired Helix, Co., La Mesa, Calif.

[0045] Submersing the photovoltaic cells in the electrolyte solution acts to concentrate solar energy into the photovoltaic cell. It will be understood that adjustments to case dimensions may be used to obtain a greater degree of light concentration. Light concentration may be achieved either

without a cover or with the concentrating cover **16**. Such aqueous submersion of photo cells increases electrical generation from the cell.

[0046] The case **12** may be of molded plastic or other materials and is manufactured in various sizes as needed. The function of the case **12** is to hold all other parts and provide a sturdy attachment to a support structure, such as to a tracking base of a tracking system, to a building, or to the ground. The case also acts as the vessel that holds the fluid electrolyte solution, and may enable the transfer and concentration of light rays onto a photovoltaic cell.

[0047] A cover **16** functions to protect the apparatus and may also act to concentrate solar radiation. The case may be provided in multiple sections that are mated together during the assembly process. These mating parts may function by slide-in compression fittings at all junctures, although other assembly techniques may be used. A single case may contain all components necessary for the production of hydrogen and electricity. The frame of this case may be attached to a building or to the ground. Cases may then be assembled in multiple units in a master frame consisting of an array of several cases. Float **80** mechanism is attached to automatically provide water and electrolyte replacement as needed during hydrogen production. Cooling-heat transfer devices **104** may be attached to the case to stabilize temperature as required by local weather conditions.

[0048] An aqueous electrolyte **20** fills the case cavity on both sides of membrane **24** to provide a source of water for splitting water into hydrogen and oxygen. Positive and negative electrical charges emanate through the electrolyte between anode **34** and cathode **36**, causing the water to split into hydrogen and oxygen. Electrolytes **20** may comprise both aqueous and polymer materials. Electrolytes may also be nonaqueous polymers capable of conducting an electric current. Polymer composites that have been used to synthesize polymeric electrolytes include polyacrylonitrile, polyvinyl pyrrolidone, and polyethylene oxide. These have low dielectric constants which lead to high degrees of ion association in polymeric electrolytes. When the base polymers are amorphous ionic conductivity is increased.

[0049] A membrane **24** may be sized and its thickness selected to yield desired production of hydrogen and oxygen. The membrane functions to control the flow of protons in the electrolyte. The membrane is a proton-exchange membrane, which serves as a solid electrolyte placed between an anode and a cathode. The proton-exchange membrane conducts protons and it does not conduct electrons. The frame **22** is provided to hold the membrane **24**. The frame is constructed in two parts and held together as self mating parts using a friction fit. An adhesive is employed to attach the frame to the case. The membrane is also impermeable to the gases produced in this process. Consequently, it maintains separation between the hydrogen evolved at a cathode **34** and the oxygen evolved at an anode **36**. Hydrogen diffuses out of the water into cathode collection chamber **40**, and collects at the top of the reservoir. Oxygen produced in the anode chamber rises to the top of its collection chamber **46**. In this way, the membrane enables the capture and collection of commercial grade hydrogen without complex separation structures.

[0050] The key for direct solar conversion is to find a light-harvesting system that efficiently collects solar energy

and directs it into the water-splitting reaction. The present embodiment does this efficiently. Hydrogen is produced as a result of voltage input by solarelectro emission from a photovoltaic cell and is applied directly through cathodes and anodes in an electrolysis reaction inside the case. Also, external electric energy may be provided using windelectro electrical turbine generation or hydroelectric generated electricity. There is no separate electrolyzer employed nor is there any electricity from utility grid required as in traditional electrolysis methodology. In the present process, electricity enters the electrolysis cavity by means of connectors in a protected housing **32** as well as protective coverings and coatings.

[0051] A photovoltaic cell **28** may be a triple-junction amorphous silicon alloy with a transparent weather resistant elastomer covering. The bottom layer of the cell absorbs the red light, the middle layer absorbs green light, and the top layer absorbs blue light. This spectrum splitting capability is important in attaining higher efficiencies. The present embodiment also includes the option, for some operating conditions, to include a triple-junction silicon photovoltaic cell with up to 34 percent efficiency that can accept higher concentrations of up to 400 suns, further reducing the output cost. These high efficiency photovoltaic cells are manufactured by Spectrolab, Inc, Sylmar, Calif. In the present embodiment such silicon cells may have a chemical resistant clear coating **102** to protect the cell from degradation. This coating may also enhance electrical generation by concentration of solar energy.

[0052] In one example the photovoltaic cell **28** may be installed in strips located to receive the focused and concentrated solar radiation. Such installation reduces the area of photovoltaic cells in the case, yet functions adequately under the concentration process. This cell produces 1.8 volts. The thermodynamic potential for splitting water into H₂ and O₂ at 25° C. is 1.23 volts as understood in the art. For ambient temperature approximately 1.6 v to 1.8 v is needed for water decomposition. In fact, current commercial electrolyzers operate between 1.7 v and 1.9 v. Converting energy of 1.9 v into a corresponding wavelength of light produces light having a λ of 650 nm, which is in the lower energy red portion of the visible spectra. This means that the entire visible spectrum of light has sufficient energy to split water into hydrogen and oxygen. The selected photovoltaic cell takes advantage of this solar radiation.

[0053] The system may include a housing **32** (see FIG. **3B**) to separate the electrical connectors between the solarelectro and windelectro sources and electrodes **34**, **36**. This space does not contain aqueous electrolyte, but functions as a means of isolating and protecting the connectors from the electrolyte and possible deterioration. Electrodes **34**, **36** function to carry electricity to electrolyte **20**. The electrodes are variously constructed of conductive materials such as stainless steel, nickel, or carbon fiber determined by the efficiency needs of the application. Holders **38** suspend the electrodes in the several configurations by means of hooks. An electro catalysts such as platinum or platinum coatings may be used along with the electrodes to increase hydrogen production. The electrodes are positioned for maximum electrolyte exposure and solar exposure. It will be appreciated that the electrodes may be alternatively positioned and dimensioned consistent with this disclosure.

[0054] Electricity may be generated external to the system, and conducted into the case to drive the electrolysis process. The external energy preferably is generated using renewable sources, such as wind or water, but may be from a commercial electric grid or generator. Electricity from the wind turbine (**FIG. 5A**) and hydroelectric (**FIG. 6A**) generating units is combined with electricity from the photovoltaic cells and is conducted to the electrodes inside the case. Conductive wires **30** or strips such as copper or other conductors, including composites, provide a continuous electrical connection between the photovoltaic cells, wind, and hydro generators and the electrodes.

[0055] Solar tracking may be used to rotate the hydrogen generation system to increase the intensity of light reaching its internal solar panel. The solar tracking structure shown in **FIGS. 4A and 4B** operates by use of drive motors to control rotation of the case. Case **12** is attached to a circular track **56** which is constructed of round tubular material. Roller glide **58** wheels attach on multiple sides to the round tube of track base **56**. Case **12** moves in circular rotation to face the solar source. An upper section of case **12** is attached at socket **60** to pivot ball **62** to operate as the rotation point for the entire case. The case will rotate at least 200 degrees horizontally. Frame base **66** provides support for the rotation apparatus and the entire case. Legs **68** level the frame base by means of a pin and a number of holes through the holding tube and the stand tube. The legs function to raise and lower the case and also to provide attachment to a structure or the ground.

[0056] Solar tracking is used in the preferred embodiment and may be used with other embodiments. Solar tracking motion control by double axis means is directed by photodiode **70**, connecting wires **74**, control boxes, and direct current electric motors **76**. The motor gears contact track **56**, which also has matching gear teeth, both vertical and horizontal. Where electricity is required for tracking motors, a separate photocell **72** may be employed to power an ultracapacitor **78**. The ultracapacitor comes from the semiconductor industry as an electrochemical unit. These capacitors contain large-surface-area electrodes with very small interelectrode gaps, and they have large volumetric capacitances. They offer better service than known batteries, taking less energy to charge them and then holding the charge longer.

[0057] The system of **FIG. 2A** typically uses solar tracking to maintain a direct concentration of solar radiation on the photovoltaic cell at the base of case **12**. The system of **FIG. 3A** may use solar tracking depending on installation site and solar radiation conditions.

[0058] Cooling-heat transfer in the cases **12** and **14** in **FIGS. 2A and 3A** applies for all embodiments for mixing the electrolyte and for cooling the case as obtained by transformative chip technology from the nanotechnology industry. Other thermo control technologies may also be used as needed. Chips **106** may be attached to the bottom of the case, either inside or outside the case. The chips are wafer-thin vacuum diodes, and use quantum mechanical electron tunneling as the primary cooling mechanism. Cooling-heating transfer chips **106** are also employed inside the electrolyte chamber to introduce a mixing and stirring effect in the electrolyte chemicals. This stirring increases the efficiency of the water splitting reaction into hydrogen and

oxygen. This stirring also allows the electrical reactants to effectively arrive at the reaction site of the water elements, thereby enhancing the electro chemical reaction, and producing more hydrogen than without such stirring. A float **80** and water inlet device functions to provide sufficient water level in the case. A float senses the water level and when the water level goes down, the water valve to which the float is attached, emits water into the case to maintain the desired water level.

[0059] Referring now to **FIG. 3A**, another hydrogen generation system is shown. The system of **FIG. 3A** has a thinner profiled case **18**, about 25.4 mm thick or less by 741.2 mm by 1366.1 mm compared to case **12** of **FIG. 2A**. Other sizes may be used depending on energy and environment requirements. The function of this thinner case is to reduce the amount of electrolyte and overall weight of the completed case for easier handling and suspension. The cover **16**, as concentrator, has a series of concave and convex surfaces on both sides as a means of focusing and spreading solar emissions over the photocell through electrolyte **20**.

[0060] This alternative hydrogen generation system employs a thin electrode **36** such as a stainless steel screen or of other thin electrode material. The membrane **24** is placed just above the thin electrode functioning as separator of the hydrogen and oxygen. Electrode bands **34** are attached around the sides of the case to allow solar exposure on the photovoltaic cell **28**. These electrodes **34** may be double layered, depending on the square centimeter surface required to obtain the desired efficiency of hydrogen production. The upper electrode **34** consists of a thin band of (perhaps 12.7 mm wide) stainless steel or other electrode material. The electrodes **34** are held in place by a holder **38**. The case **14**, has a collection chamber **40**, emitting tube **42** and a hydrogen purification module **44**, a monitoring and measurement system designed to process the hydrogen to make it available for a wider range of applications. A similar purification module **50** is in place for oxygen processing on the oxygen emitting tube **48**. This embodiment also has the float **80** for water and electrolyte replacement. The hydrogen measurement device **44** is a well-known solid-state hydrogen sensor connected to a computer-based data system to record output.

[0061] The electrical connectors **52** from the photovoltaic cells lead outside the case **14** in **FIG. 3A** for two uses: 1) Provide direct current outside of the case; direct current may be sent to a traditional electrolyzer or to serve other electrical needs; 2) electrical connectors **30** bring outside-generated direct current to the electrodes. Such incoming direct current electricity may be made with wind turbines that may have air speed concentrators as illustrated in **FIG. 5**, or may employ or other generators. The incoming direct current is employed to produce hydrogen by the present electrochemical process.

[0062] The system of **FIG. 3A** may produce hydrogen by direct solar **10**, wind (**FIG. 5A**), or hydro (**FIG. 6A**) powered electrochemical reaction with an aqueous electrolyte. The system also has a lens concentrator and employs a mesh anode beneath the membrane and an encased photovoltaic cell. The cathodes of conductive metal strips and wire are positioned around the outer casing to provide direct solar radiation passage through the thin aqueous electrolyte. This allows the solar energy to reach the photovoltaic cells

unobstructed. This equipment set provides opportunity for electrical current to pass into the electrolyte via the anode and cathode. The aqueous solution functions as a solar concentrator. The novel concave and convex lens concentrators built into the transparent cover **18** of this alternative embodiment also serve as solar concentrators. Cooling and electrolyte stirring are provided by vacuum diode **104**, **106**.

[0063] In FIG. 3A, the generation system operates using a case **14** with a profile that is thinner and lighter in weight than the system of FIG. 2A, yet produces hydrogen and oxygen by the same direct photoelectrochemical reaction, with an aqueous or polymeric electrolyte and lens concentrators. Where a solid electrolyte is employed as the proton-exchange membrane, sandwiched between a catalytic anode and a catalytic cathode, water without acid is used to yield hydrogen. Lynntech, Inc. College Station, Tex. is a source of such an alternative electrochemical system. The mesh anode **36** is located beneath membrane **24** with an encased photovoltaic cell **28**. Cathode **34** of conductive metal strips and wire is positioned around the outer casing to provide direct solar radiation to pass through lens **18** and aqueous electrolyte **20**. This location allows solar energy **10** to reach the photovoltaic cell **28**, and allows electrical current to pass into the electrolyte via the anode and cathode. The aqueous solution works as a concentrator as well as does the unique concave and convex type lens **18** that are concentrators built into the case cover **18**. The concentrator may also employ a Fresnel lens and other means of light concentration including a series of concave and convex markings on both sides to concentrate light on the photovoltaic cell **28**.

[0064] The system of FIG. 3A employs a thin electrode **36** such as a stainless steel screen, about 0.228 mm with a strand 0.254 mm or of other thin electrode material. Dexmet Corporation of Nautuck, Conn. makes such a screen. The membrane **24** is placed just above the thin screen electrode **36**. Above the membrane is the photocell **28**. Located just above the photocell **28**, an upper electrode **34** consists of a thin band (perhaps 1.27 cm wide) of stainless steel or other electrode material. This electrode material is attached around the border on electrode suspension holders **38** and may be double layered. The secondary embodiment also has the float **80** system for water and electrolyte replacement. The cooling device is also available **104** and the cooling-heat chip **106** creates mixing of the electrolyte.

[0065] Both embodiments, FIG. 2A and FIG. 3A, include a housing **32** or space to separate the electrical connectors between the photovoltaic cells and the electrode. FIG. 3B shows the housing with connecting wires. This space does not contain electrolyte. The electrodes **34**, **36** are constructed variously of conductive materials such as stainless steel, nickel, composites, polymer composites, carbon fiber, or other electrode material. The electrodes are suspended in the several configurations by means of holders **38** or hooks.

[0066] The connections between the photovoltaic cells **28** and the electrodes **34**, **36** are accomplished by using wires **30** or an option of strips such as copper or other conductive materials including an option for composite conductors.

[0067] FIGS. 2A & 3A show a gas product collection chamber **40**, with emitting tubes **42**, a hydrogen purification device **44**, with monitoring, and measurement systems **82** for the products produced. These gas processing equipments are conventional and are not shown. Purification is accom-

plished by equipment such as is available from H-lon Solar, Inc, Richmond, Calif. as Model: PT-4-H2. H-lon Solar, Inc. This company also makes a product for purifying Oxygen Model: PT-4-02. Makel Engineering, Inc. Chico, Calif. produces hydrogen measurement equipment as does McMillan Company, Georgetown, Tex. These are solid-state hydrogen sensors and recorders and can be incorporated into desktop computer data processing systems. An oxygen monitor and measurement systems **50** can also be obtained from the above sources. The cooling and heat transfer chips **104**, **106** for mixing and stirring the electrolyte and for heat control of the cases **12**, **14** are available from Cool Chips of Gibraltar.

[0068] FIG. 4A shows examples for a solar tracking device consisting of a structure and attachment mechanism, with drive mechanism. An attachment **54** of case **12** to a track **56** is formed in a circular design and is round so that roller glide wheels **58** can stay in constant controlled contact with the round track and can guide the tracking unit in a circular rotation to face the solar source. The upper section of the case **12** is attached at a socket **60** to a pivot ball **62**. The frame base **64/66** provides support for the rotation apparatus and the entire case. The legs **68** have adjustable attachment to provide leveling of the frame base by means of a pin and a number of holes through the legs. The leg system can thus allow raising and lowering of the tracking device to adapt to a structure configuration. A double axis type solar tracking motion control is directed by photodiode **70**, connecting wires **74**, control boxes, and direct current electric motors **76**. The motors have pulleys with matching gears with a geared track **56** at both vertical and horizontal assemblies. Industrial Indexing Systems, Victor, N.Y. can provide an integrated positioning system that includes each piece of equipment for single and double axis motion control. An alternative tracking system is not shown on the drawings but it can replace the tracker items. It rotates the present case embodiments to follow the sun by shifting the weight of a liquid refrigerant from the east to west canisters through a transfer tube. A useful assembly is available from Zomeworks, Corp., Albuquerque, N. Mex. The electrolyte level may be maintained by a float **80** and water inlet device that can be connected to an available water source.

[0069] FIG. 5A is a perspective view of the wind turbine with a funnel concentrator **84**. The funnel concentrator is mounted on a post **98**, and has rotation sleeves **96** enabling the funnel concentrator to rotate. A directional wind fin **86** may be used to rotate the funnel concentrator into the wind. Multiple sets of turbine vanes may be positioned in the concentrator. Each set of vanes is rotated by the wind and drives a turbine generator **88**. Turbine vanes **92** are slightly concave or flat on the side facing the wind. FIGS. 5B, 5C, and 5D show that the side of the vanes away from the wind are convex to yield aerodynamic reduction of the pressure in that space, which pressure is below atmospheric pressure. The shroud **100** covers and holds the wind turbine as shown in FIG. 5A. the shroud may be tapered to have a smaller opening on the wind-out end as compared to the wind inlet. Reduced pressure in the turbine will act to pull air through the turbine. In this turbine in order to increase electrical generation by the turbine, the vanes as shown in FIG. 5C are set with leading edge **92** facing the wind. The vanes **92** are shaped and positioned as in FIG. 5B so wind hits the bottom of the vane and pushes it. The top of the vane is convex and tapered toward the rear. This aerodynamic design provides

lift to the blades in the same direction that the wind is pushing the blade. The wind travels over the convex side creating lift to further pressure the turning of the turbine for electrical generation. The front and rear blade **92** systems rotate independently allowing the rear blades to be turned by the wind that results from the wind and vacuum created by the front set of blades. The turbine blades are convex on one side and flat or concave on the other side so that in the presence of wind for rotation, they will produce a reduction of the pressure in a space below atmospheric pressure to aid in rotation power. A common brake and speed control **94** is used to moderate the speed at which the blades spin. Industrial electric turbine generators **88** are obtainable commercially in the industry from such companies as Oregon Wind Corporation, Portland, Oreg.

[**0070**] Wind concentration is achieved by a funnel device which compresses and concentrates what wind energy may be available to enhance electrical output of the generator and hydrogen production. Wind concentration makes it possible to produce hydrogen from the case in twilight and night conditions when no solar exposure is available. Wind turbine energy generation and photoelectrochemical process combined takes advantage of low sun areas, but also can produce hydrogen twenty four hours a day when wind and hydro energy are available. With traditional stationary solar cell settings, full sunlight is not available to the cells during the entire day. Calculations of available, useable sun range from 5.5 to 6.2 hours per day, even in the strong southern sun locations in the United States. This present embodiment process includes solar tracking to increase solar time exposure for the solar assisted hydrogen producing process.

[**0071**] **FIG. 6A** is a perspective view of the centrifugal-disk hydro generator system. This generator is for placing in on-site streams for generating electricity to input into the hydrogen electrochemical generating cases **12** & **14**. The centrifugal impellers **112** and the disks **114** are attached to the same shaft, and couple to the generator **110** through a known drive connector **116**. These two impeller systems **112** & **114** are combined together to increase turning power of the generator in all conditions as well as in small streams and slower moving water. Disks **114** are included that allow moving water to impinge on the sides of the disks to aid in moving and turning the shaft, and hence adding power to the electric generator. Electricity generated by this hydroelectric method may increase the production of hydrogen in the electrochemical process whenever hydro conditions exist to augment solar radiation or wind energy.

[**0072**] The present hydrogen generation system also may include local storage of generated hydrogen gas. In one example, the gas may be stored in a flexible bladder storage unit. The bladder has an outer layer that will preferably be a composite polymer layer as padding to protect the entire storage unit. A strong layer, including fibers, will serve as base for an inner layer. An inner coating will include polymer material capable of preventing hydrogen dispersion through the wall of the storage unit. The unit is constructed for storing and carrying a chemically aggressive gas such as hydrogen.

[**0073**] Although the description above contains many specificities, these should not be construed as limiting the scope of the invention, but as merely providing illustrations of some of the presently preferred embodiments of this

invention. For example, the case may have other sizes and shapes, such a circular, oval, trapezoidal, triangular, etc. The concentrator can have similar or other shapes than those just listed. The case may be thinner or thicker as desired to improve efficiency. The apparatus for the base frame and tracking mechanism may take other configurations, including fixed position, or rotation on a fixed pole, attached to a roof, or permanently fixed on a post on the ground. Solar tracking may be accomplished by thermal shifting of heat sensitive chemicals. A photodiode tracker is of another nature, such as laser directed power. Hydrogen may be collected directly without purification as there are uses for unprocessed hydrogen. Other types of electrolytes may be employed, such a potassium hydroxide or non-aqueous electrolytes. Certain polymer composite electrodes may also be introduced into these embodiments.

[**0074**] While particular preferred and alternative embodiments of the present invention have been disclosed, it will be appreciated that many various modifications and extensions of the above described technology may be implemented using the teaching of this invention. All such modifications and extensions are intended to be included within the true spirit and scope of the appended claims.

What is claimed is:

1. A device for generating hydrogen gas, comprising:
 - a vessel holding an electrolyte solution;
 - a membrane in the vessel arranged to form a chamber;
 - a cathode in the chamber and positioned within the electrolyte solution;
 - an anode in the vessel but not in the chamber and positioned within the electrolyte solution;
 - a hydrogen gas collection area in the chamber;
 - a hydrogen gas exhaustion arrangement coupled to the gas collection area; and
 - an electric source connected to the cathode and the anode.
2. The device according to claim 1, wherein the electric source includes a photovoltaic cell in the vessel.
3. The device according to claim 2, further including an external electric source switchably coupled to the cathode and the anode.
4. The device according to claim 2, wherein the electrolyte and the photovoltaic cell are arranged so that the electrolyte acts to concentrate light rays onto the photovoltaic cell.
5. The device according to claim 2, wherein the vessel has a transparent cover, the transparent cover is constructed to concentrate light rays onto the photovoltaic cell.
6. The device according to claim 5, wherein the cover includes a lens structure.
7. The device according to claim 1, wherein the electrolyte solution is a mixture of water and an acid or salt.
8. The device according to claim 1, wherein the electrolyte solution is a mixture of water and a polymeric gel-type electrolyte.
9. The device according to claim 1, wherein the electrolyte solution is a mixture of water and a solid electrolyte.
10. The device according to claim 1, wherein the membrane is arranged to form an oxygen chamber and the anode is in the oxygen chamber.

- 11.** The device according to claim 1, further including:
 a second membrane arranged to form a second oxygen chamber; and
 a second anode in the second oxygen chamber and positioned within the electrolyte solution.
- 12.** The device according to claim 1, further comprising:
 an oxygen collection area in the vessel; and
 an oxygen gas exhaustion arrangement coupled to the oxygen gas collection area.
- 13.** The device according to claim 1, wherein the membrane passes protons but not electrons.
- 14.** The device according to claim 1, wherein the membrane does not pass hydrogen gas.
- 15.** The device according to claim 1, wherein the electric source is a photovoltaic cell external to the vessel.
- 16.** The device according to claim 1, wherein the electric source is a hydroelectric turbine.
- 17.** The device according to claim 16, wherein the hydroelectric turbine has disks and impellers mounted alternately on a shaft, with the disks and impellers positioned in moving water and cause the shaft to turn responsive to water flow.
- 18.** The device according to claim 1, wherein the electric source is a wind turbine.
- 19.** The device according to claim 18, wherein the wind turbine uses a funnel concentrator to direct wind to a set of vanes, each vane having a convex shape above the leading edge and concave shape below the leading edge.
- 20.** The device according to claim 1, further including a cooling-heat transfer chip in thermal communication with the electrolyte and coupled to the electric source.
- 21.** A method for generating hydrogen gas, comprising:
 generating an electric current;
 applying the electric current to a cathode and an anode, the cathode and the anode being immersed in an electrolyte solution;
 conducting protons through a membrane;
 generating a hydrogen gas at the cathode and an oxygen gas at the anode;
 using the membrane as a barrier between the hydrogen gas and the oxygen gas; and
 exhausting the hydrogen gas.
- 22.** The method according to claim 21, further including:
 positioning a photoelectric cell in a vessel holding the electrolyte; and
 generating the electric current with the photoelectric cell.
- 23.** A device for generating hydrogen gas, comprising:
 a vessel having a transparent cover;
 a membrane arranged in the vessel to form a hydrogen chamber and an oxygen chamber;
 a cathode positioned in the hydrogen chamber;
 an anode positioned in the oxygen chamber;
 electrolyte solution in the hydrogen chamber, the electrolyte solution at a level sufficient to cover the cathode, but allowing a hydrogen collection space;
 electrolyte solution in the oxygen chamber, the electrolyte solution at a level sufficient to cover the anode, but allowing an oxygen collection space;
 a solar cell in the vessel and positioned so that light can pass through the transparent cover, the electrolyte solution, and onto the solar cell;
 power conduits connecting the solar cell to the anode and to the cathode so that electricity generated by the solar cell drives an electrolysis process;
 a hydrogen exhaust coupled to the hydrogen chamber; and
 wherein the membrane is a proton-passing membrane, and the membrane restricts hydrogen from passing from the hydrogen chamber into the oxygen chamber, and restricts oxygen from passing from the oxygen chamber into the hydrogen chamber.
- 24.** The device according to claim 23, further including a wind-driven electric turbine connected to the cathode and the anode.
- 25.** The device according to claim 23, further including a water-driven electric turbine connected to the cathode and the anode.
- 26.** The device according to claim 23, wherein at least one of the anode or the cathode comprises platinum.
- 27.** The device according to claim 23, wherein at least one of the anode or the cathode comprises a metallic composite material.
- 28.** A method for generating a gas, comprising:
 generating an electric current;
 applying the electric current to a cathode and an anode, the cathode and the anode being immersed in an electrolyte solution;
 conducting protons through a membrane;
 generating the gas at the cathode or the anode;
 using the membrane as a barrier to contain the gas; and
 exhausting the gas.

* * * * *