



US 20050146076A1

(19) **United States**

(12) **Patent Application Publication**
Alexander et al.

(10) **Pub. No.: US 2005/0146076 A1**

(43) **Pub. Date: Jul. 7, 2005**

(54) **3-D FABRICS AND FABRIC PREFORMS FOR COMPOSITES HAVING INTEGRATED SYSTEMS, DEVICES, AND/OR NETWORKS**

(52) **U.S. Cl. 264/257**

(76) Inventors: **Bogdanovich Alexander**, Apex, NC (US); **Wigent Don**, Greenville, NC (US)

(57) **ABSTRACT**

Correspondence Address:
JINAN GLASGOW
300 N. GREENE ST., SUITE 1600
P.O. BOX 2974
GREENSBORO, NC 27401 (US)

A 3-D fabric preform for composites including a three-dimensional engineered fiber preform formed by intersecting yarn system components; and at least one system, device, and/or network integrated with the preform for providing a predetermined function, wherein the at least one system, device, and/or network is introduced prior to formation of a composite structure including the preform, thereby providing a 3-D fabric preform for composites. Also, a method for forming the 3-D fabric preform for composites including a three-dimensional engineered fiber preform formed by intersecting yarn system components; and at least one system, device, and/or network integrated with the preform for providing a predetermined function, wherein the at least one system, device, and/or network is introduced prior to formation of a composite structure including the preform, thereby providing a 3-D fabric preform for composites.

(21) Appl. No.: **10/716,959**

(22) Filed: **Nov. 19, 2003**

Publication Classification

(51) **Int. Cl.⁷ B27N 3/10**

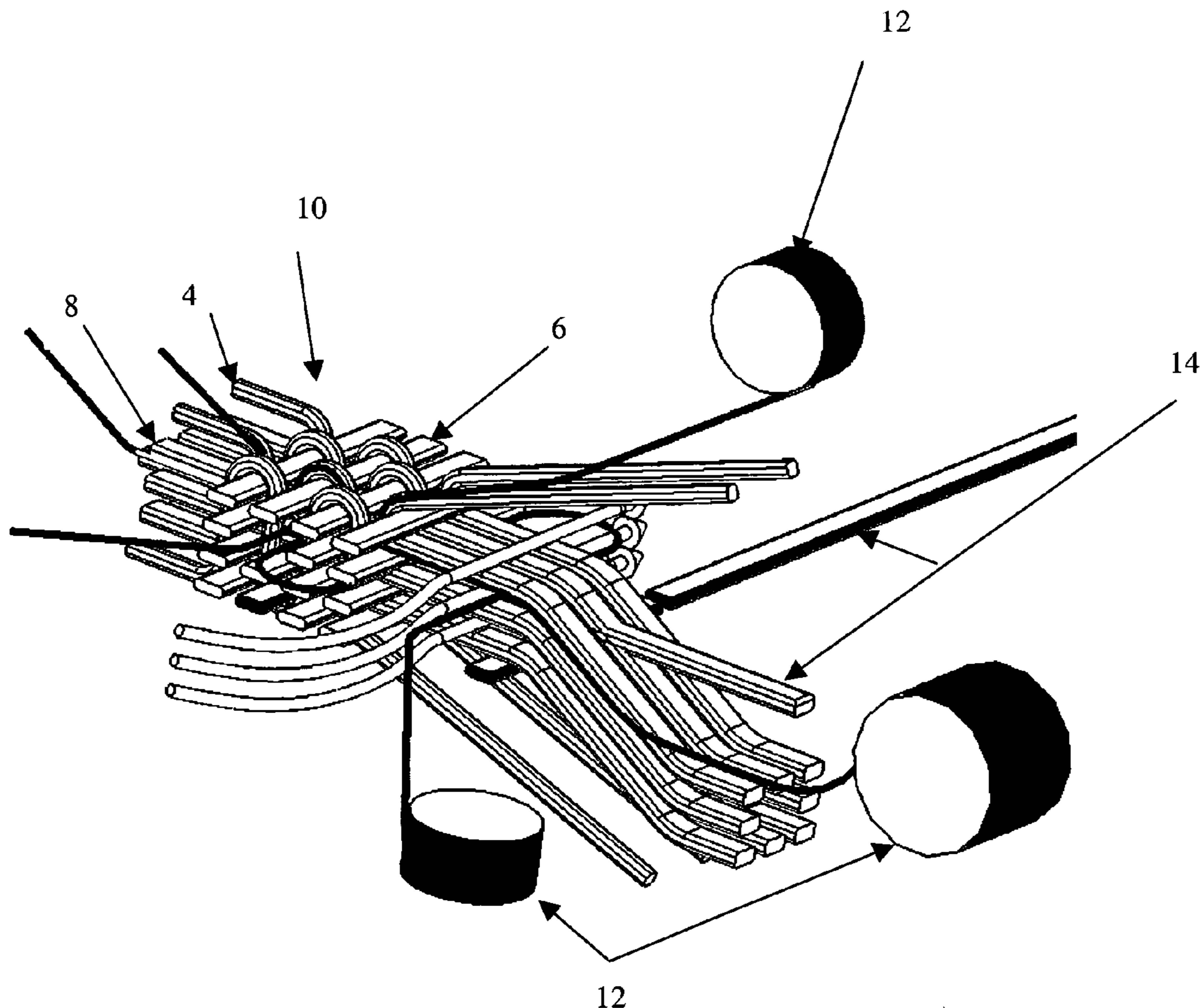

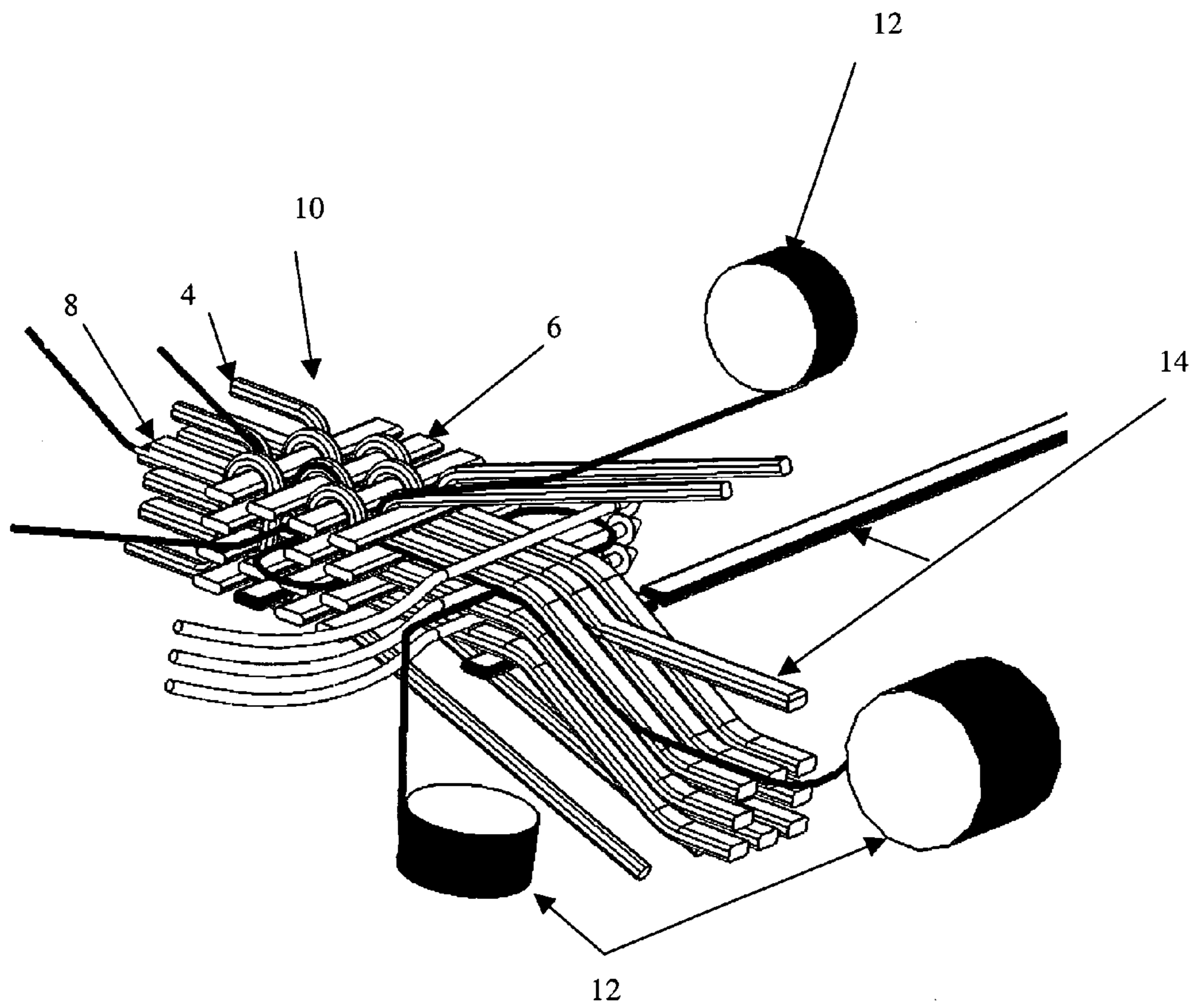

Fig. 1

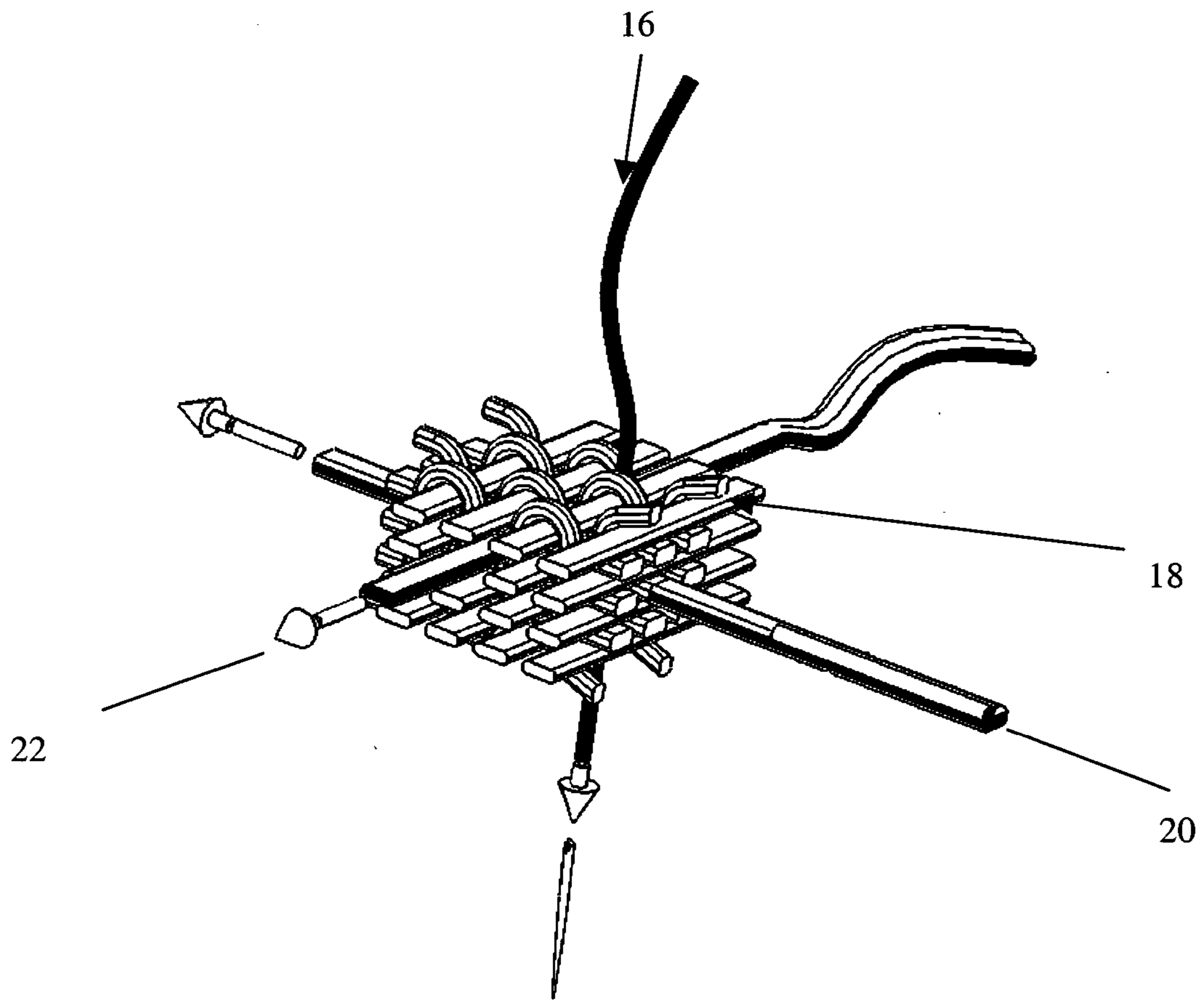

Fig. 2

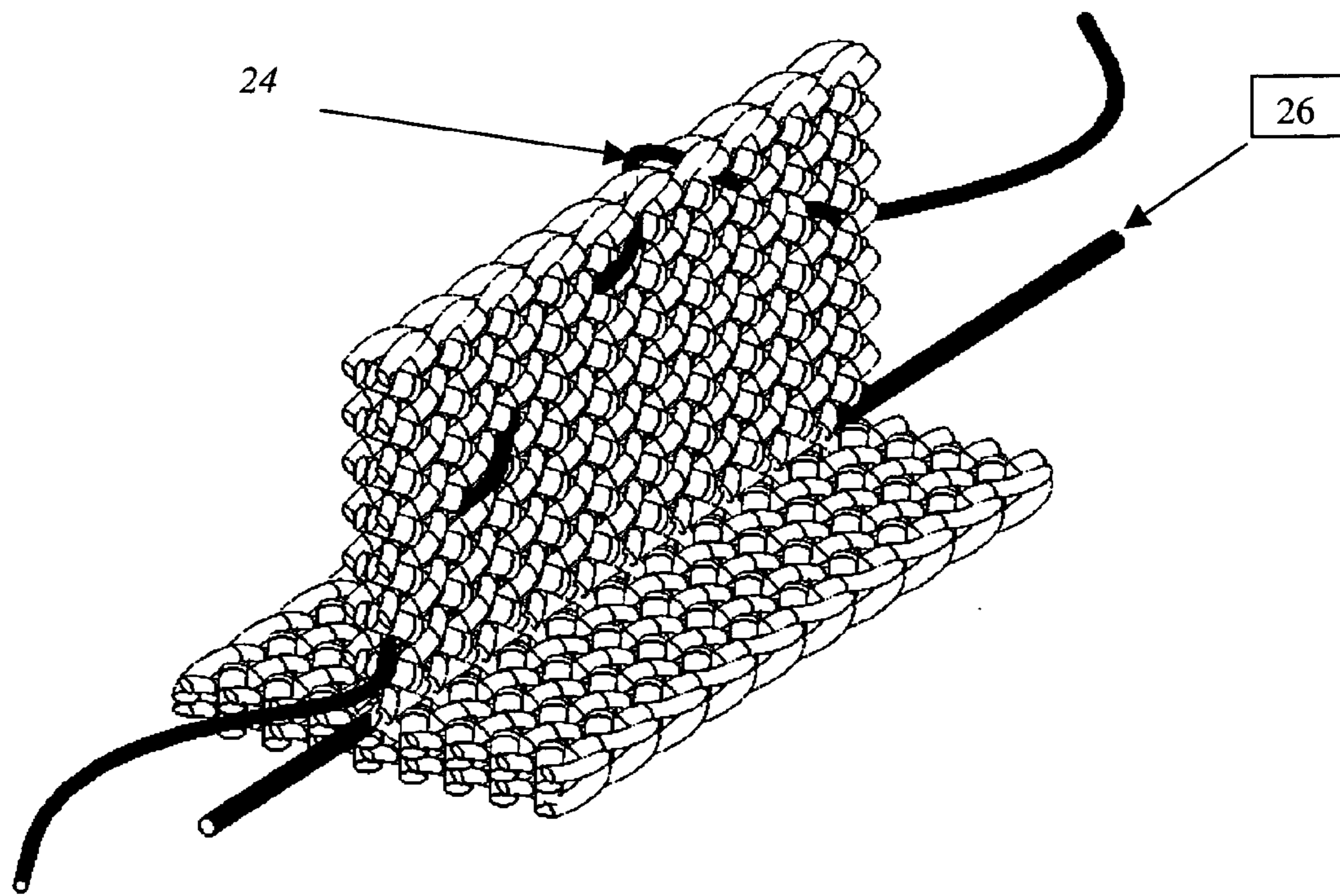

Fig. 3

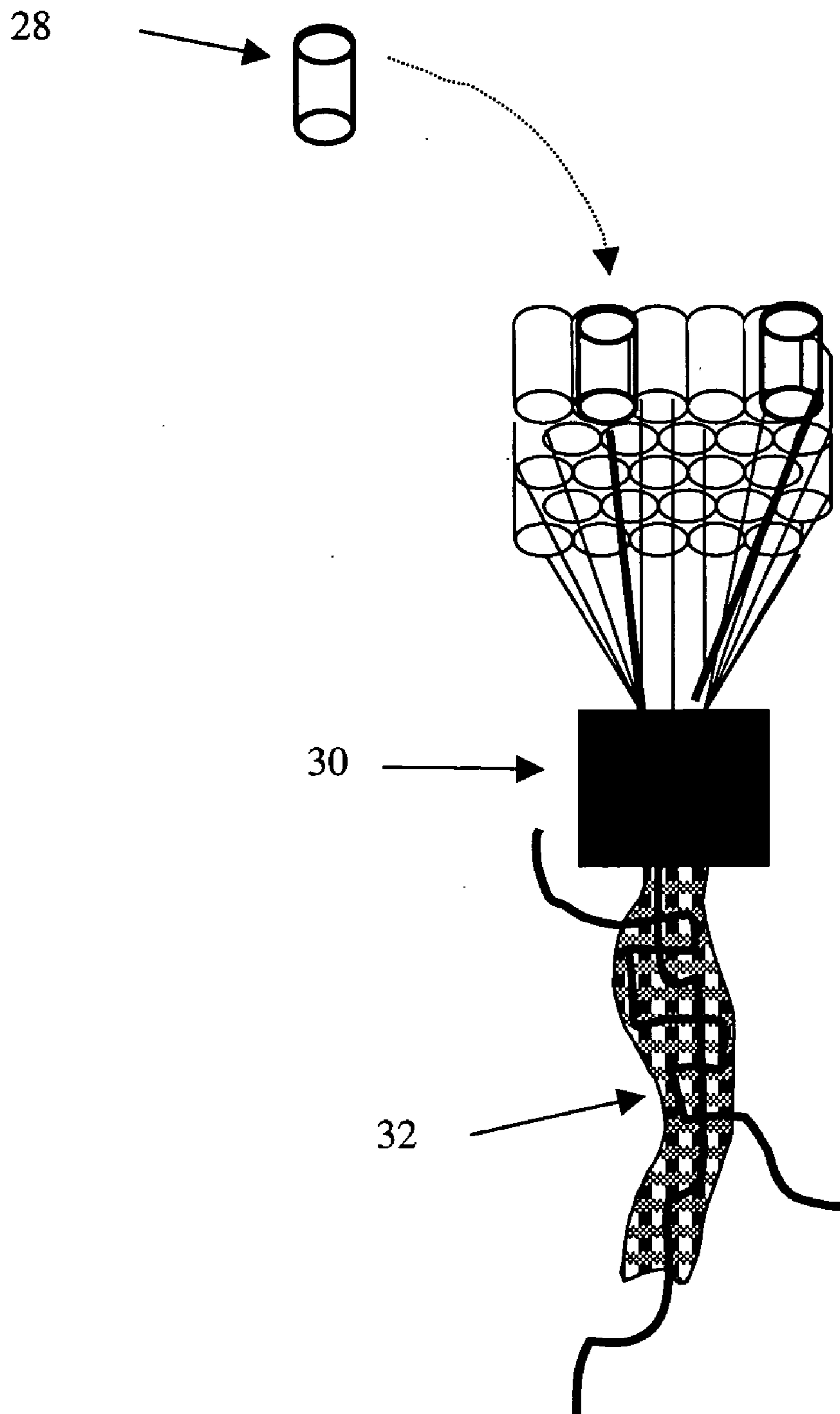

Fig. 4

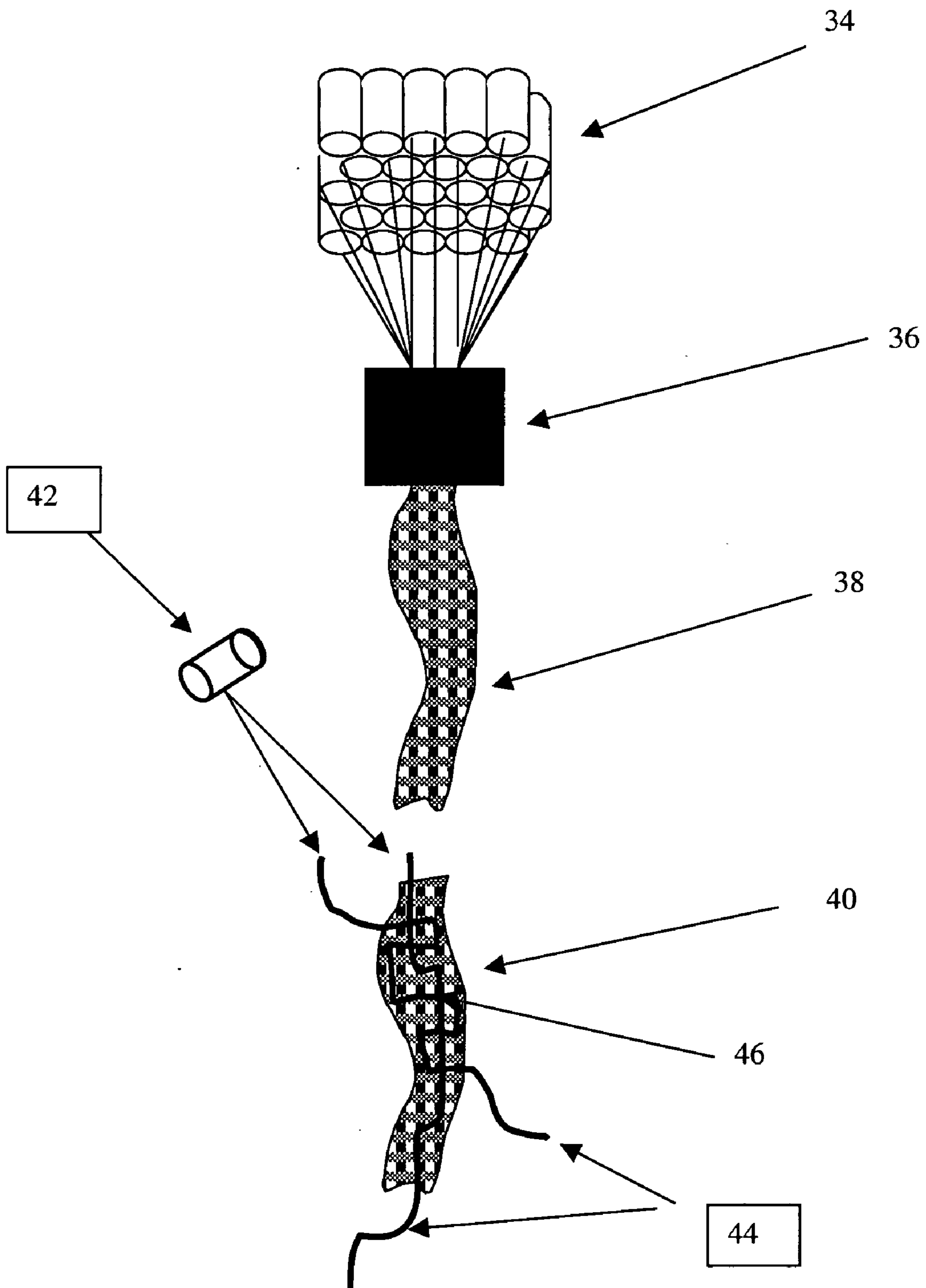

Fig. 5

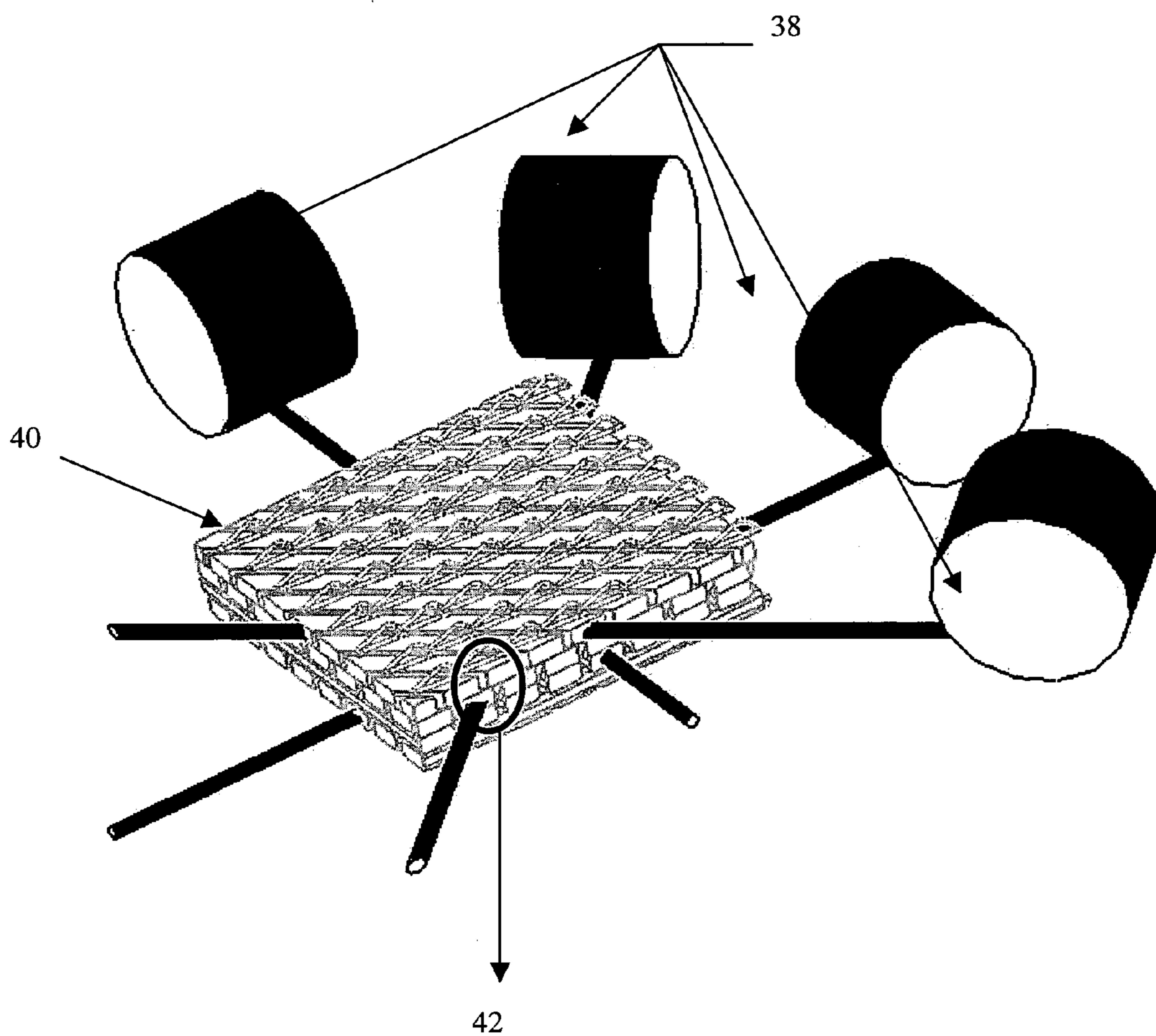

Fig. 6

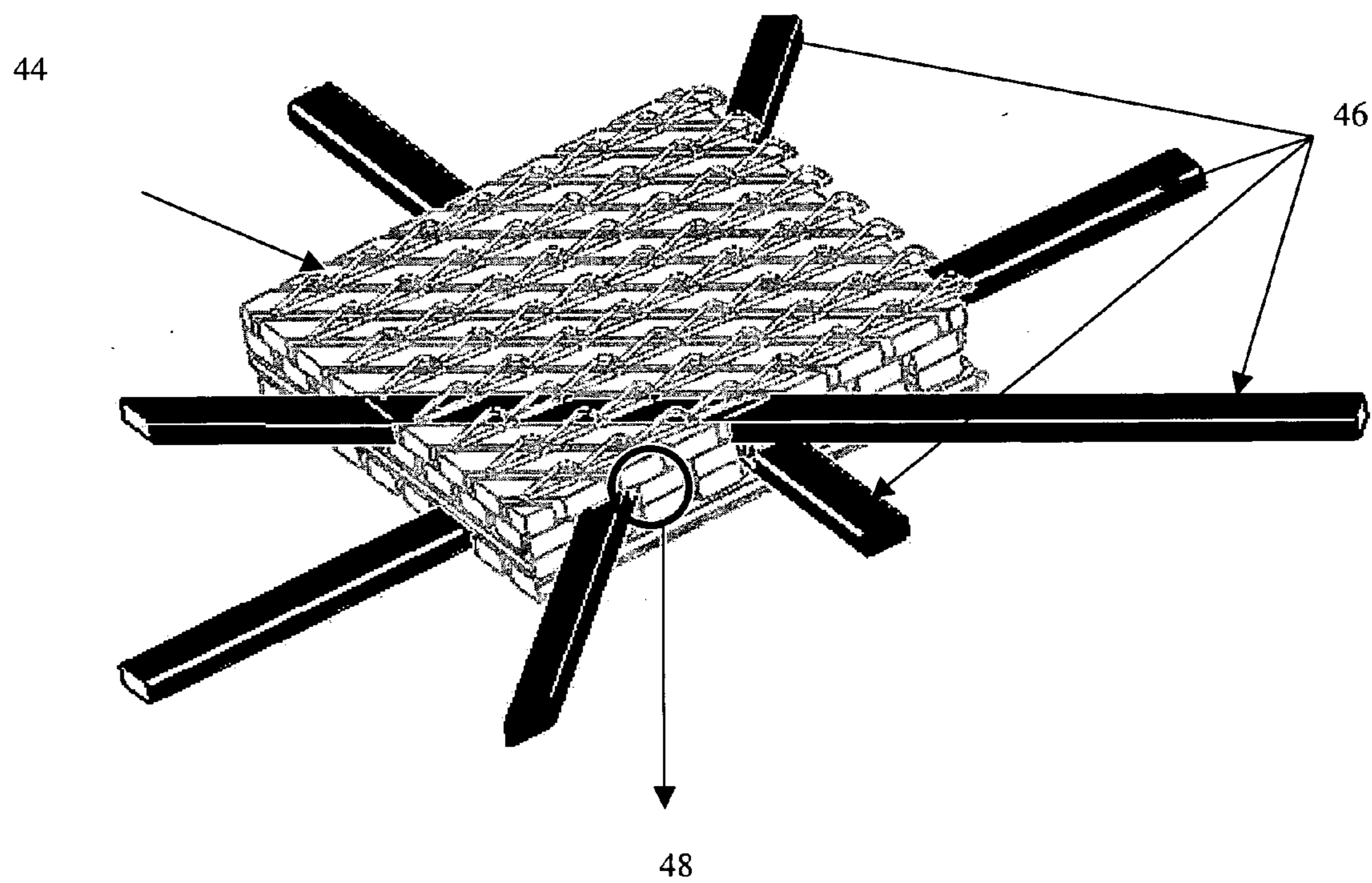

Fig. 7

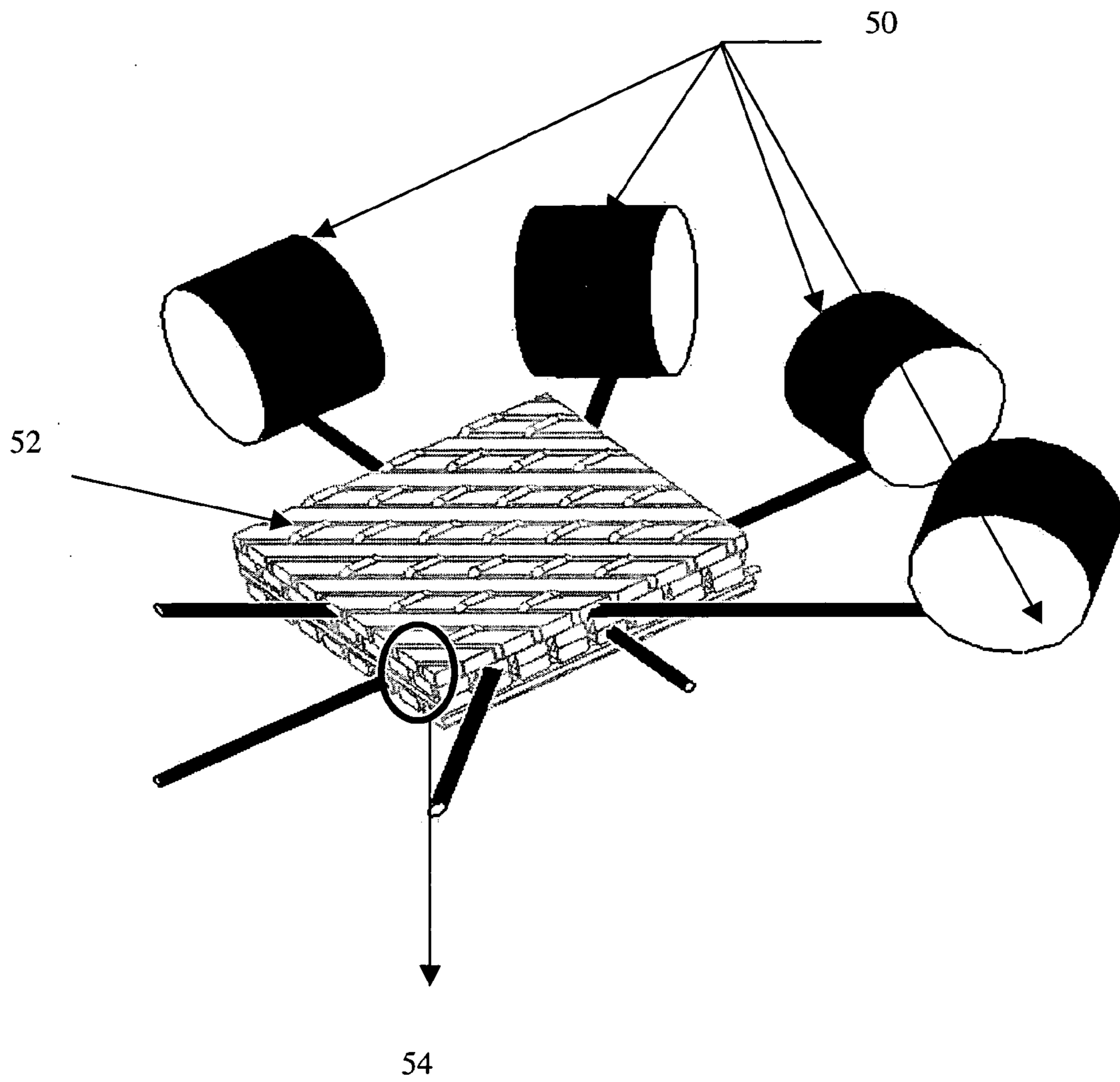

Fig. 8

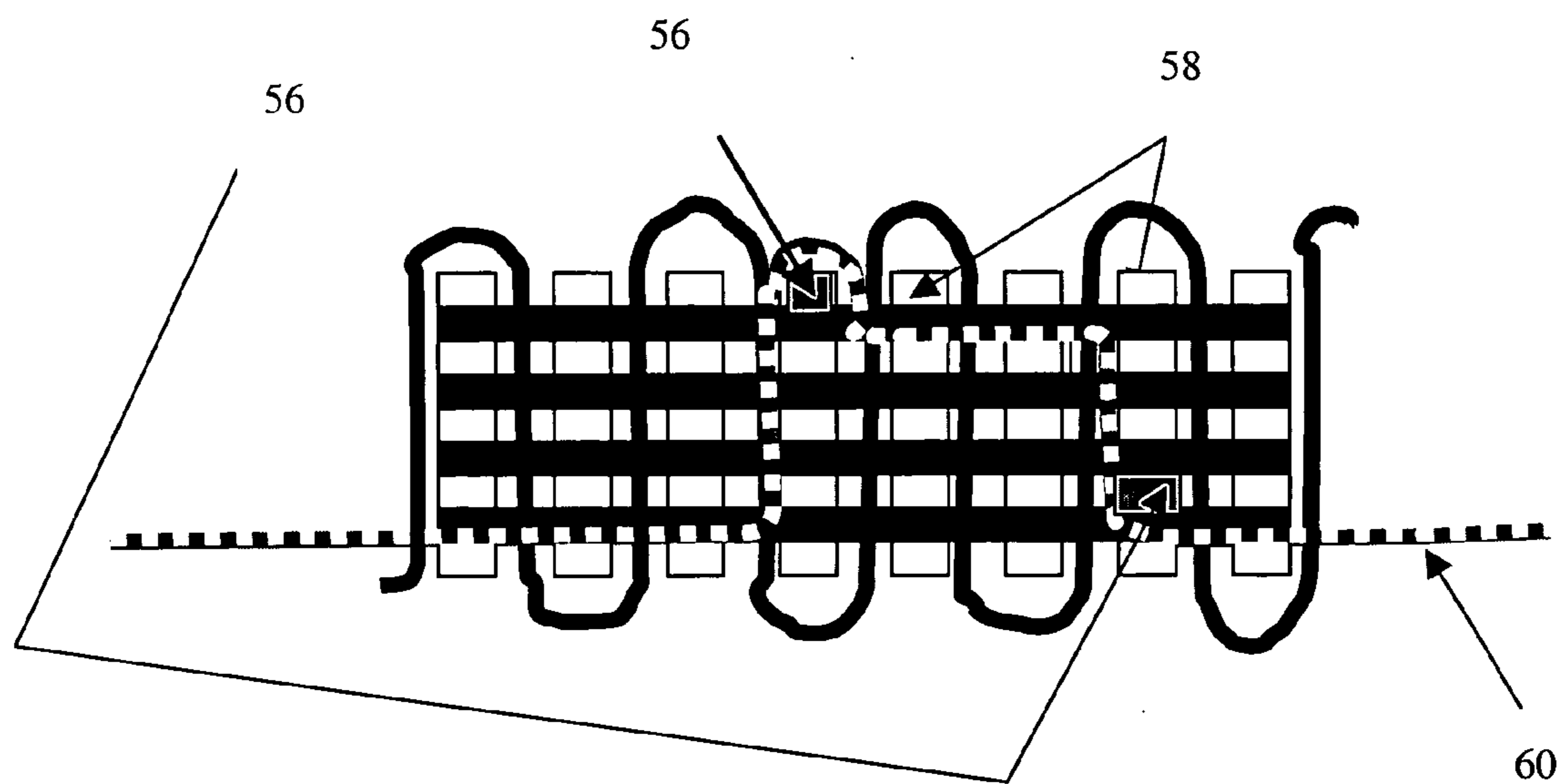

Fig. 9

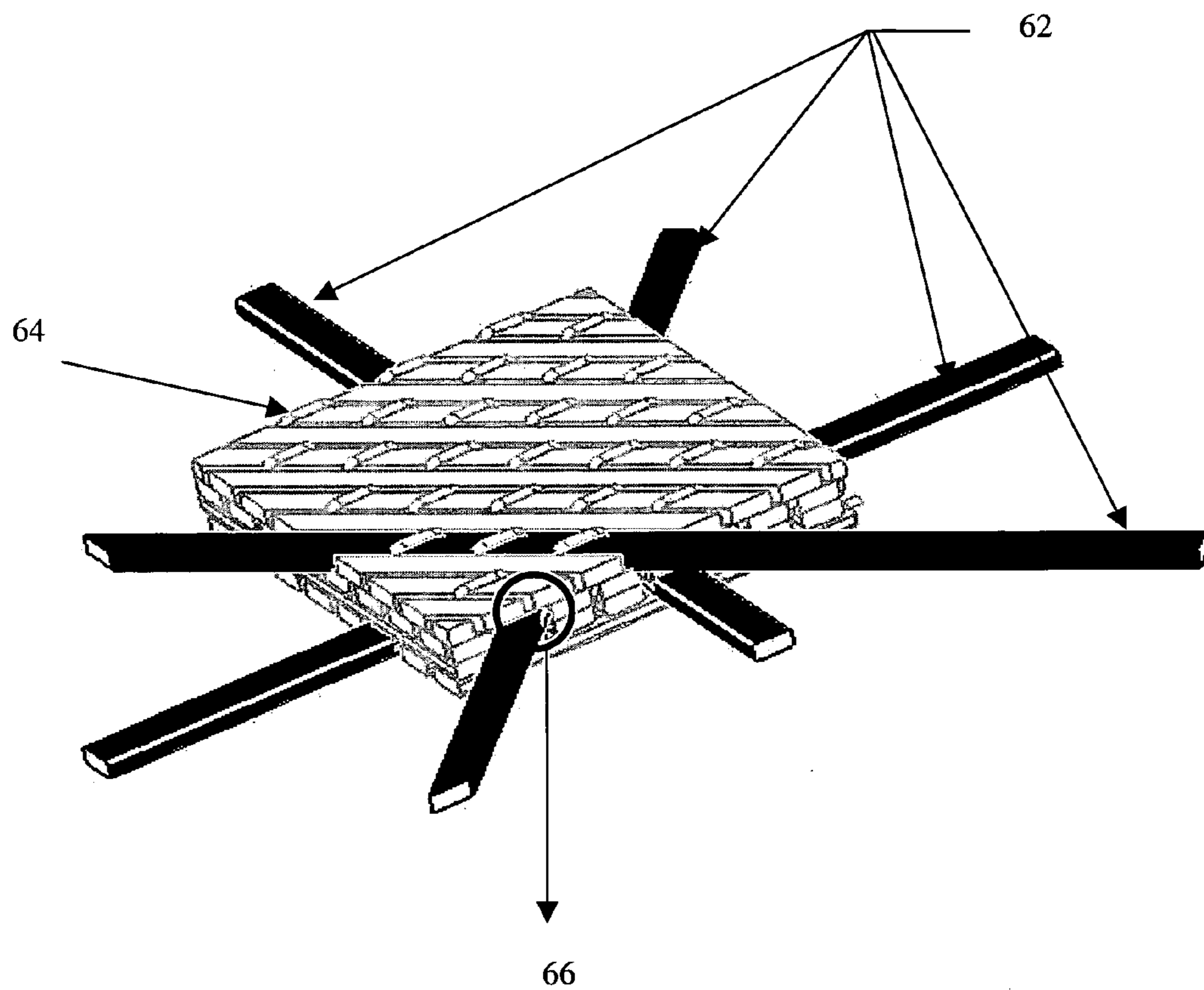

Fig. 10

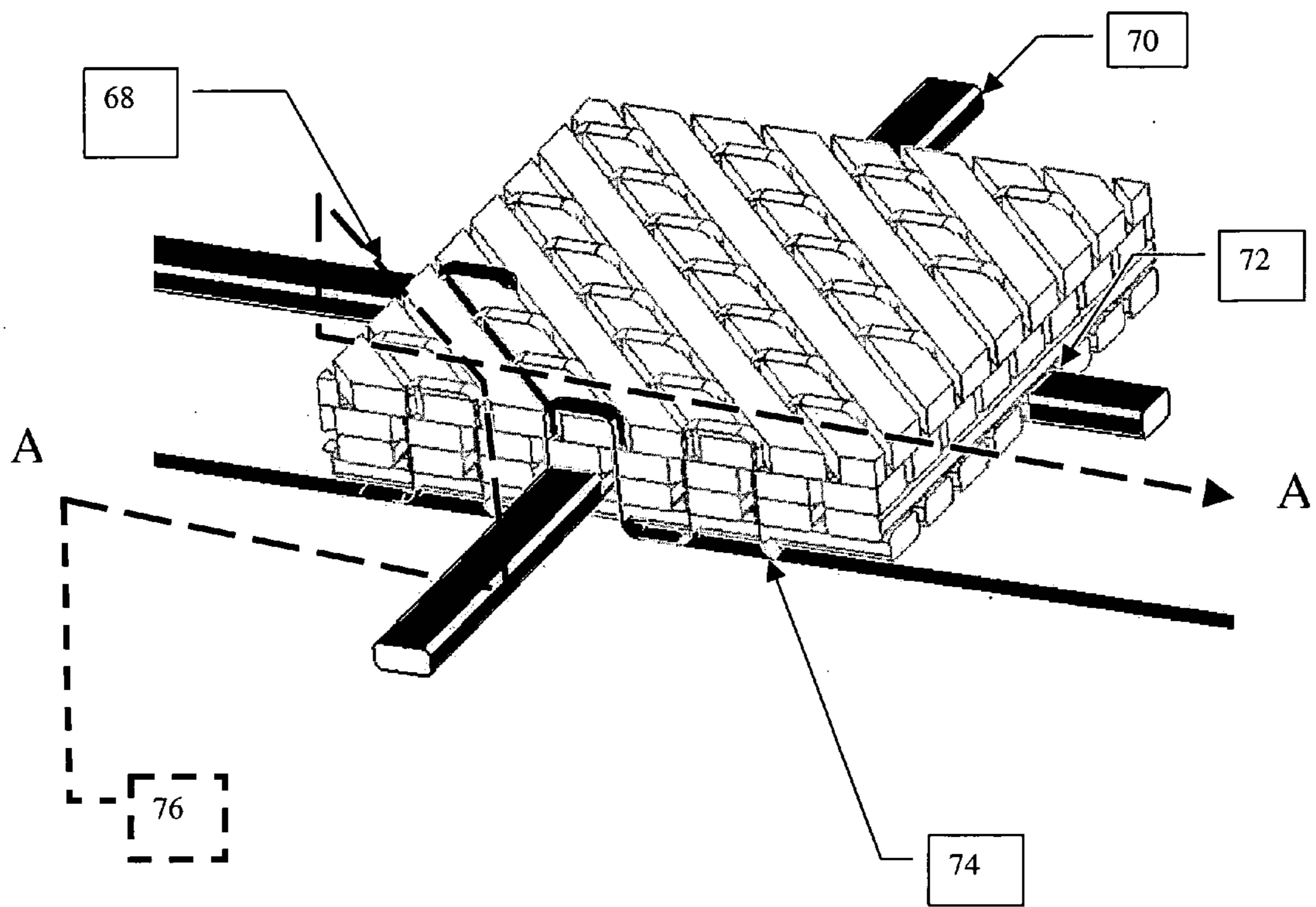

Fig. 11

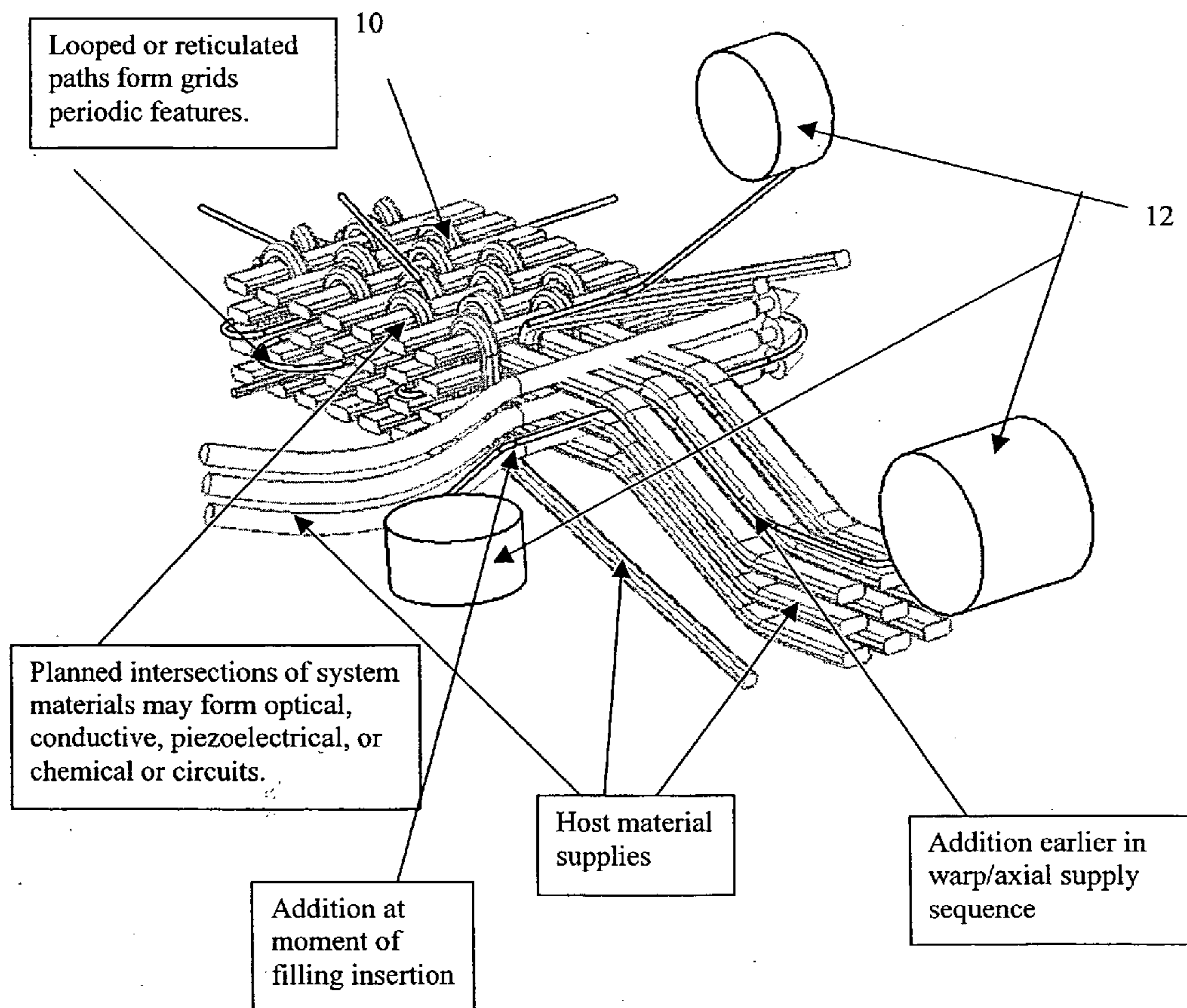

Figure 12

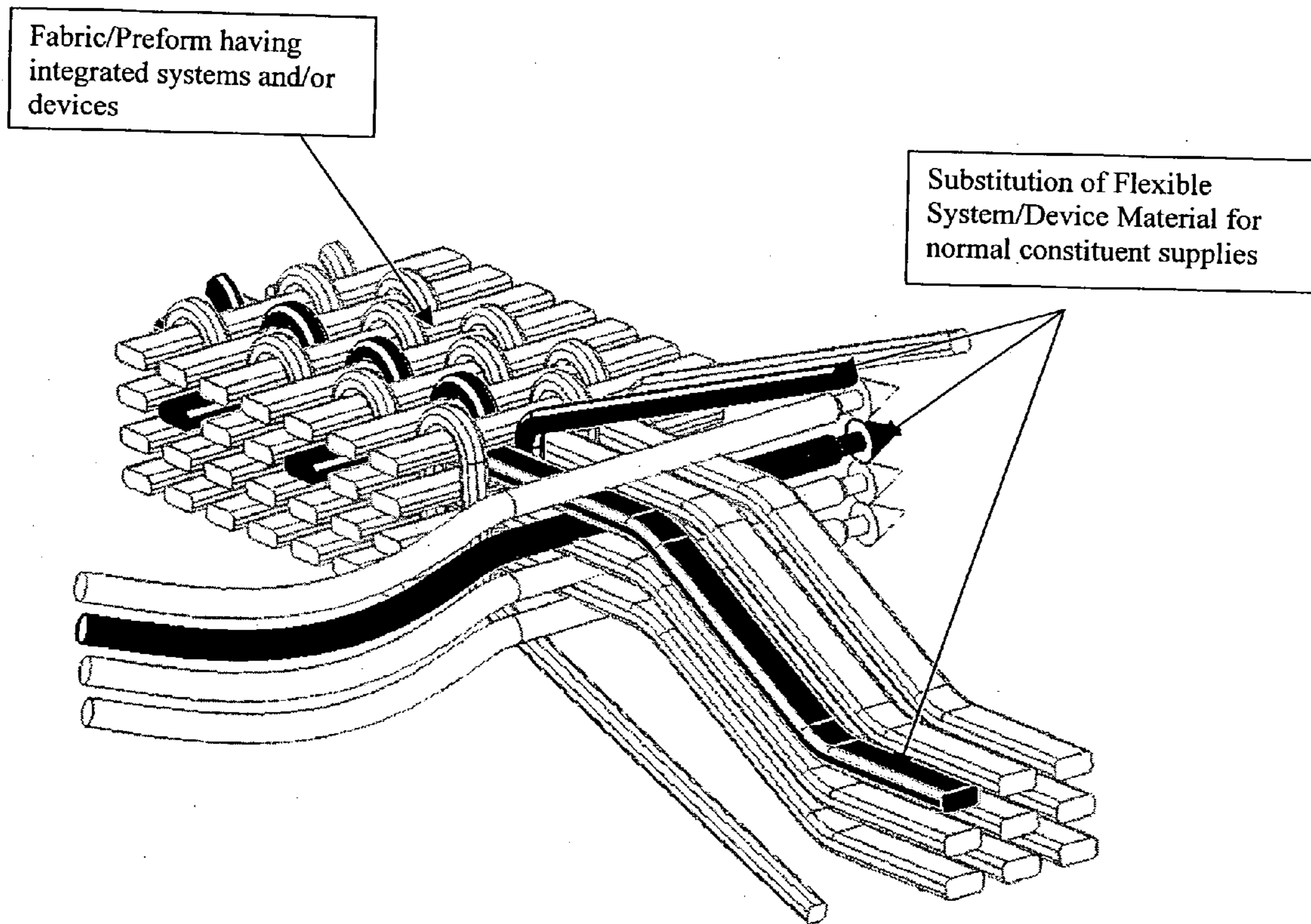

Figure 13

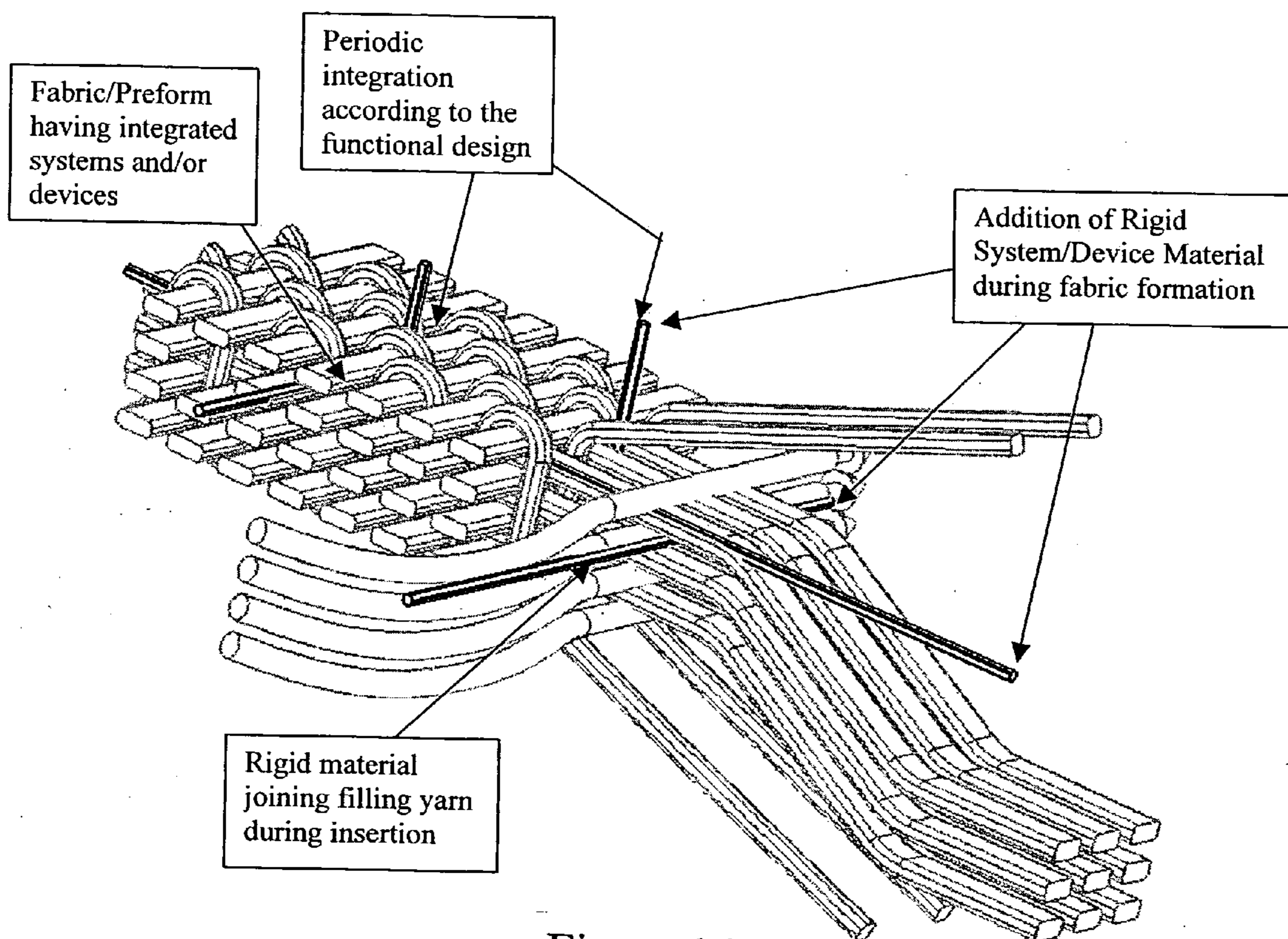

Figure 14

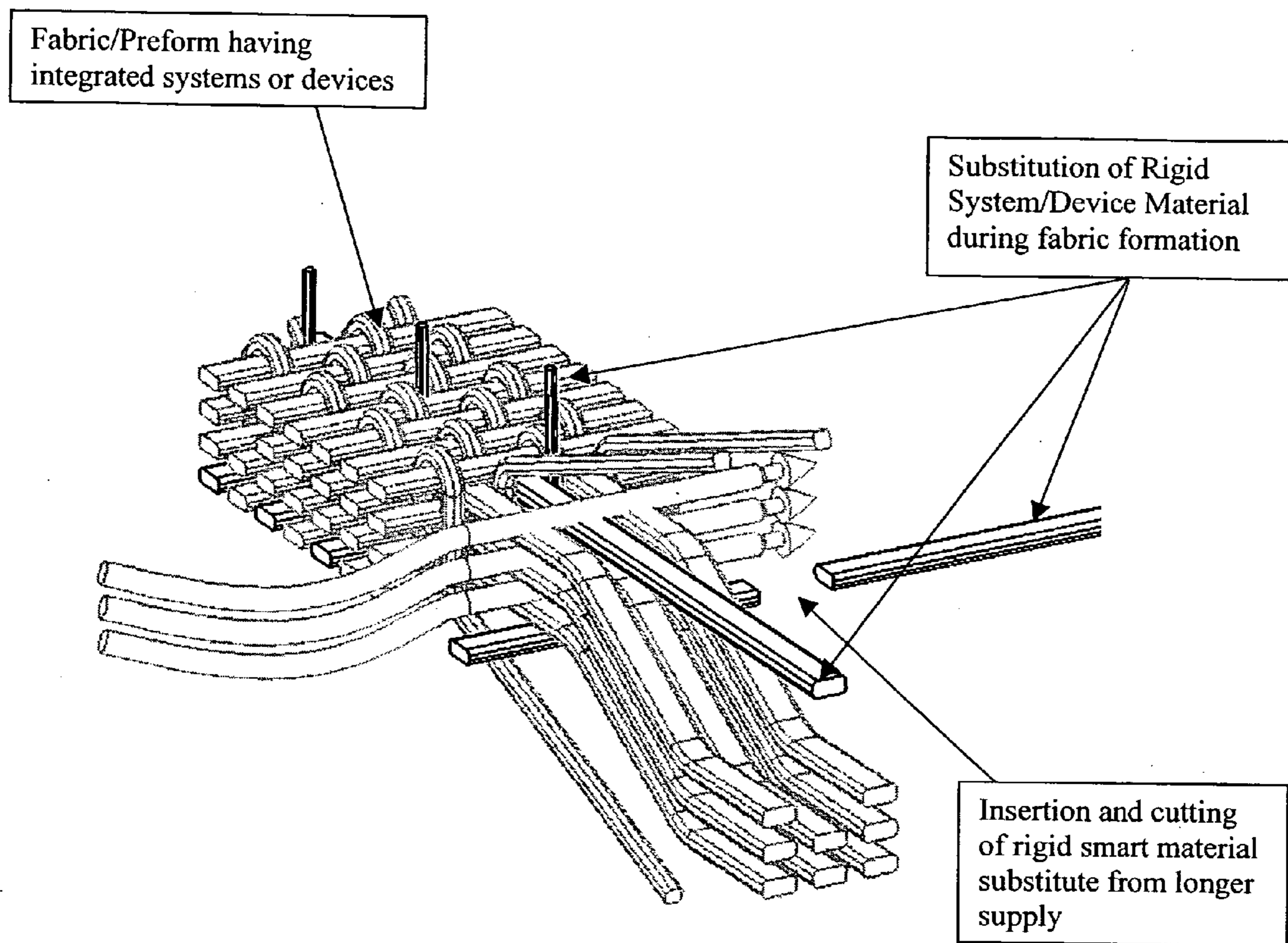

Figure 15

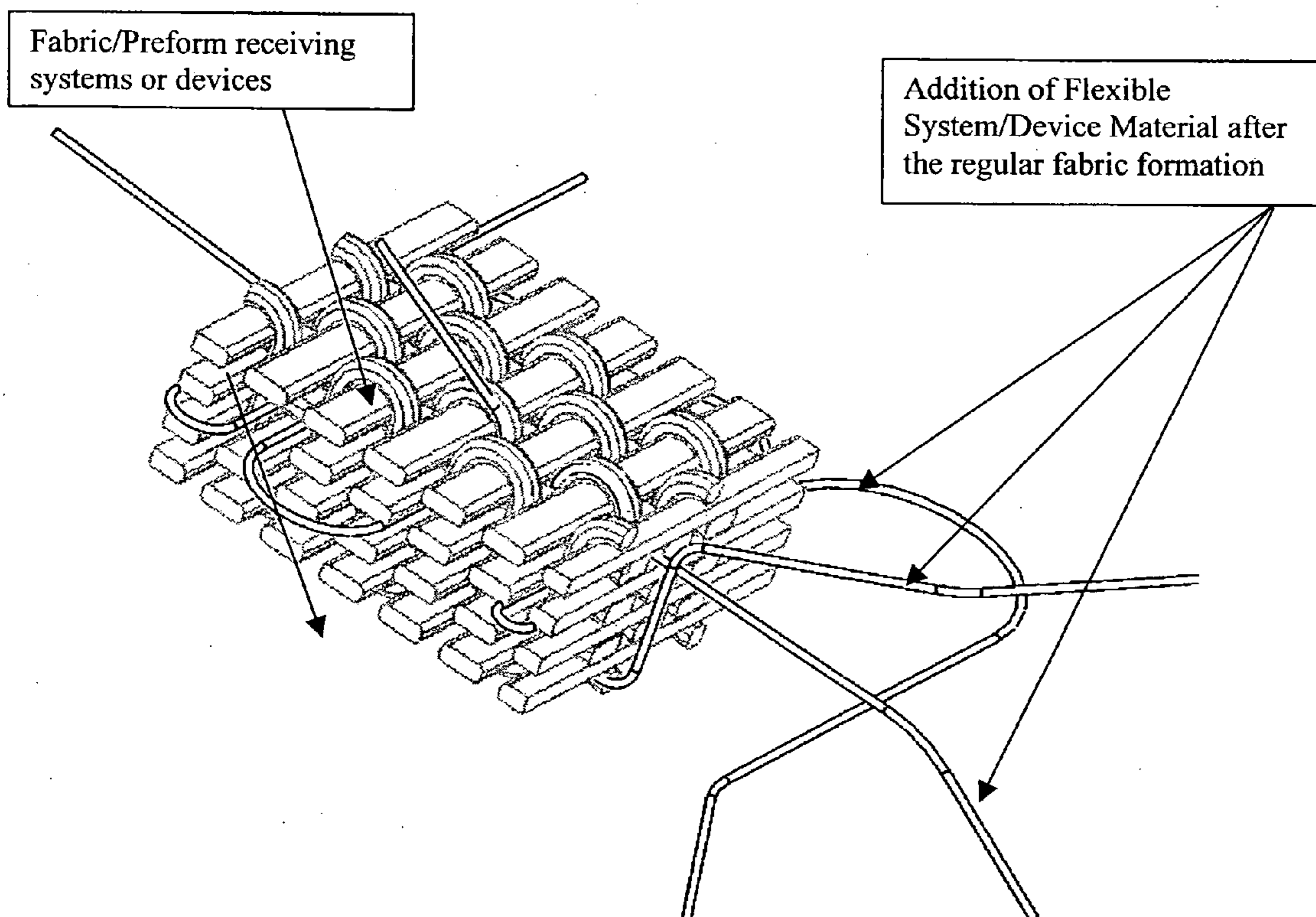

Figure 16

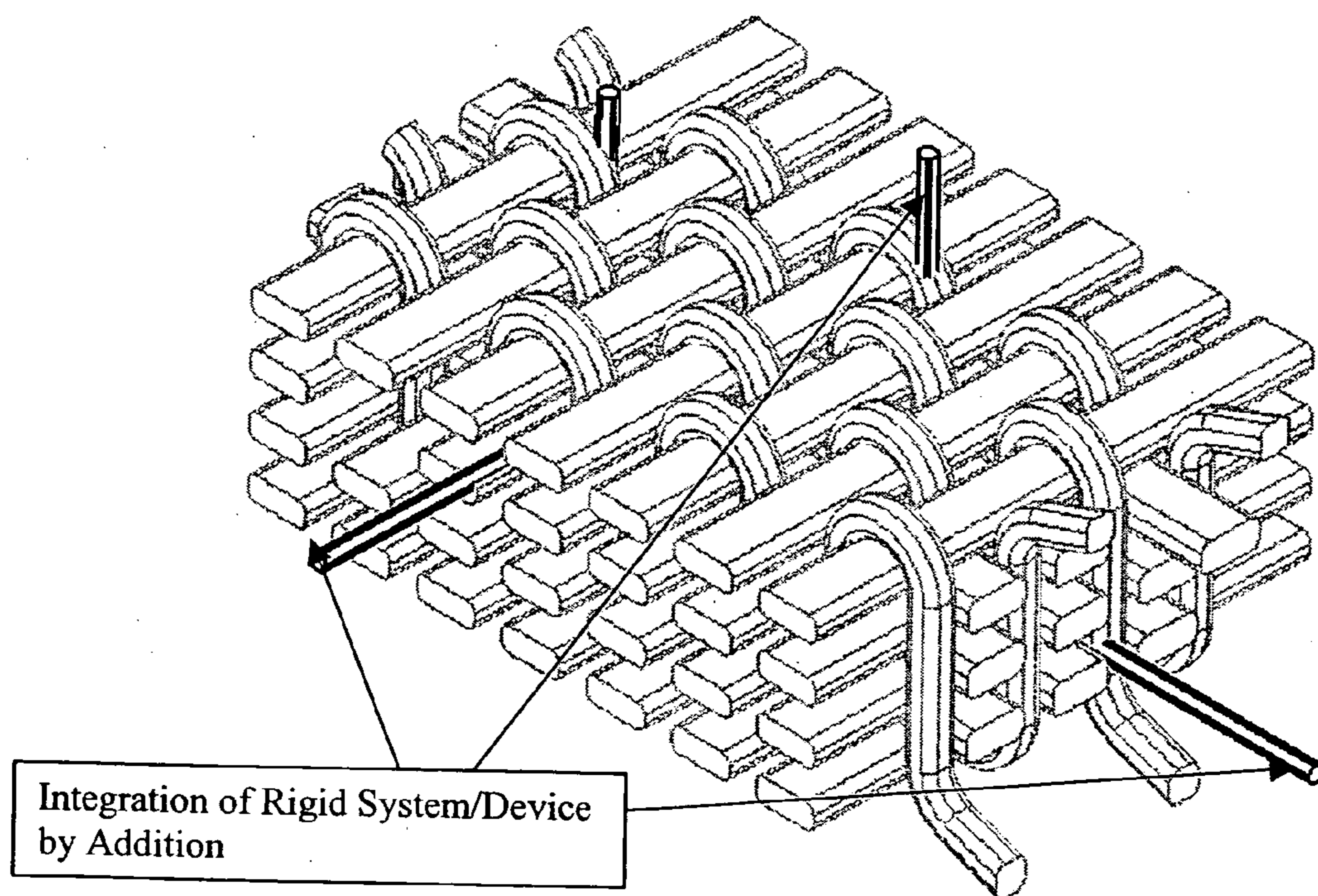

Figure 17

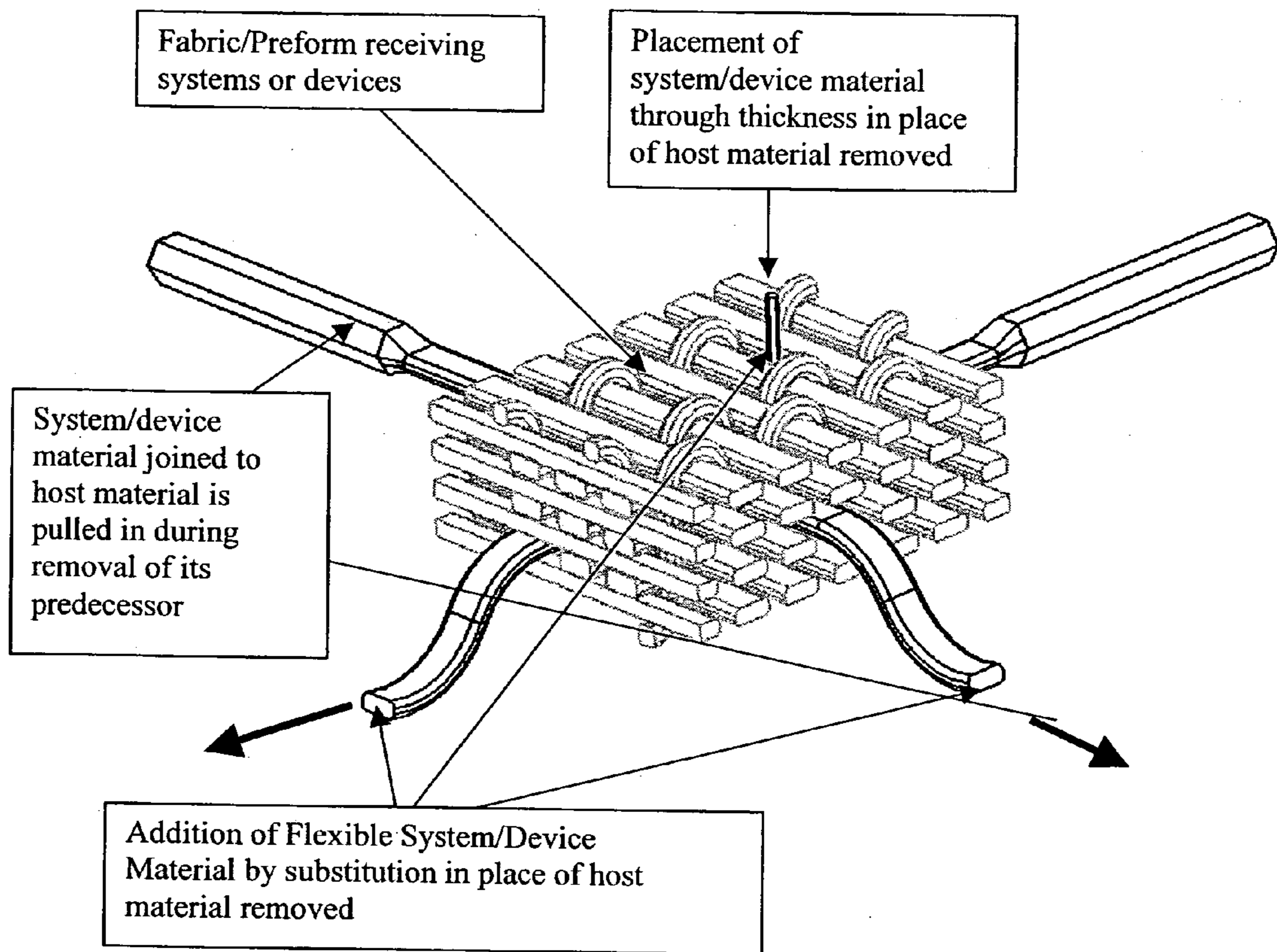

Figure 18

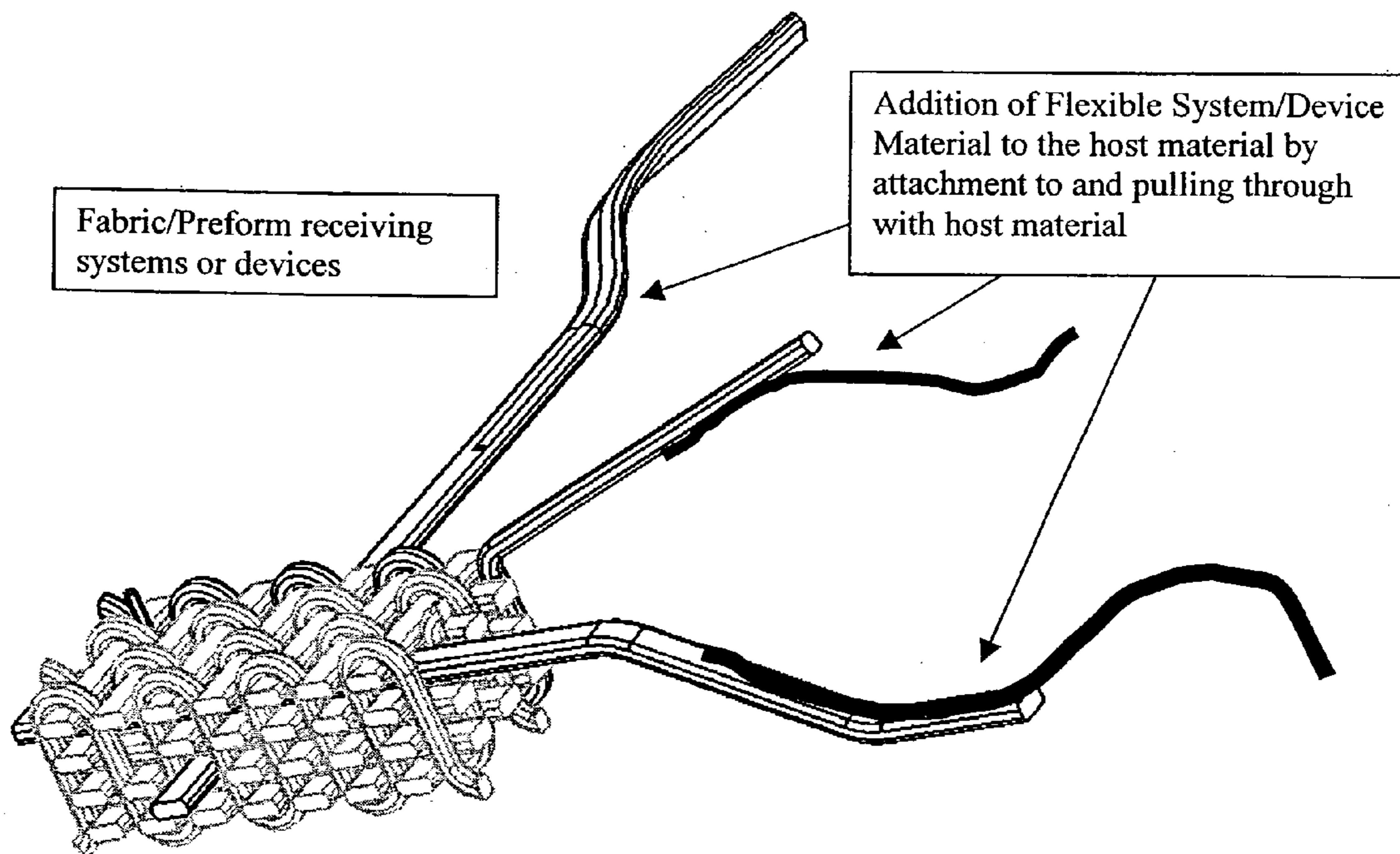

Figure 19

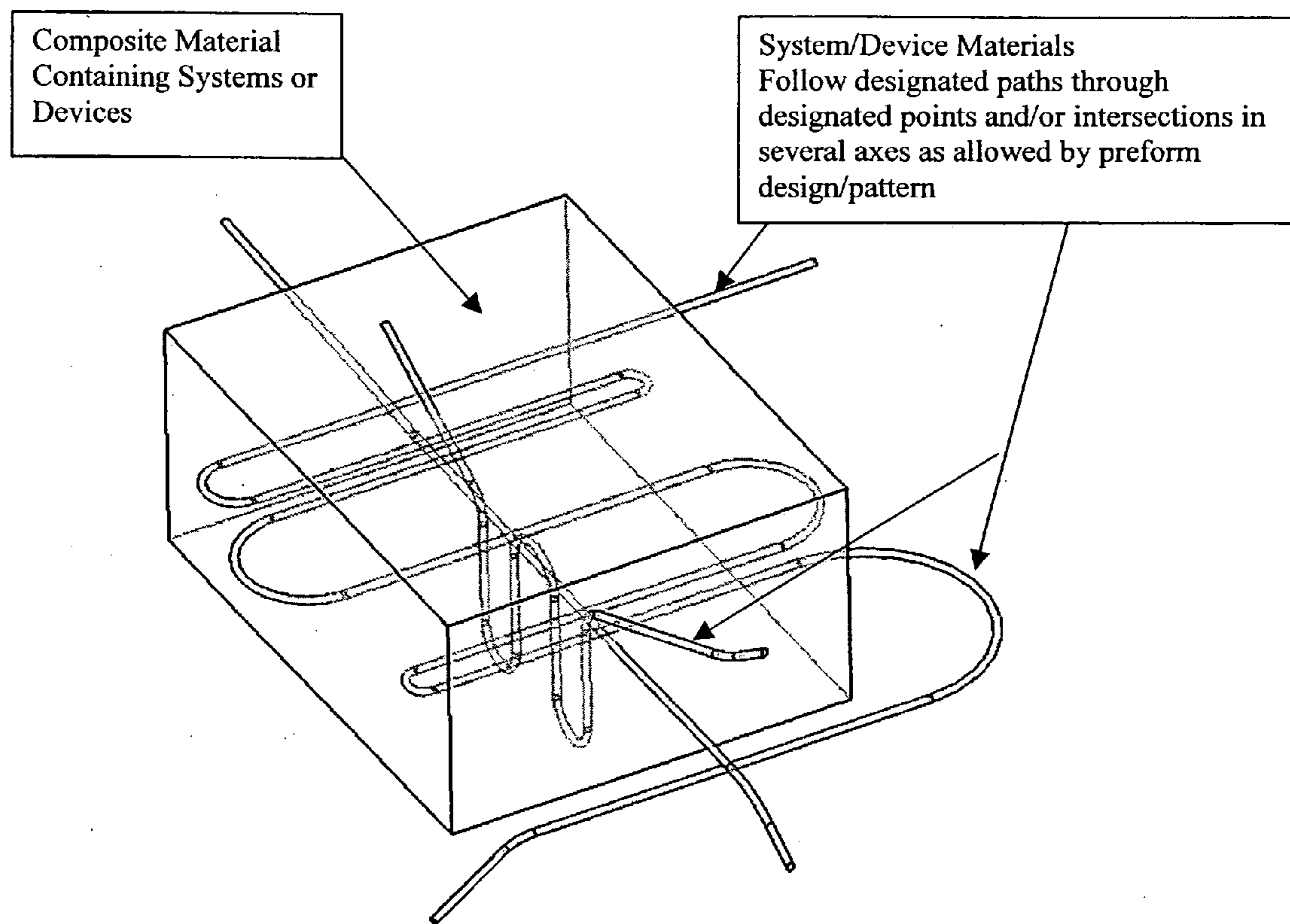

Figure 20

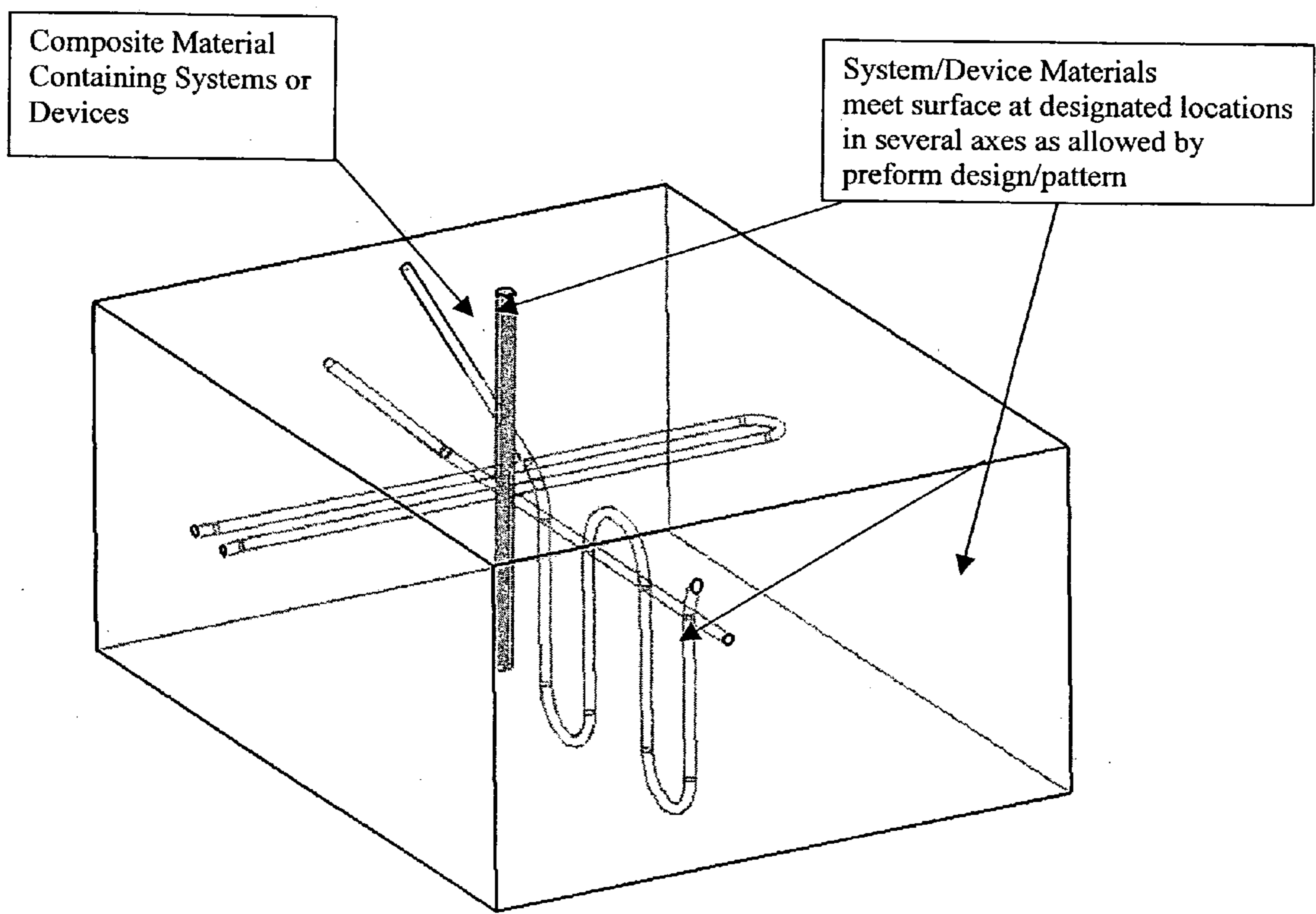

Figure 21

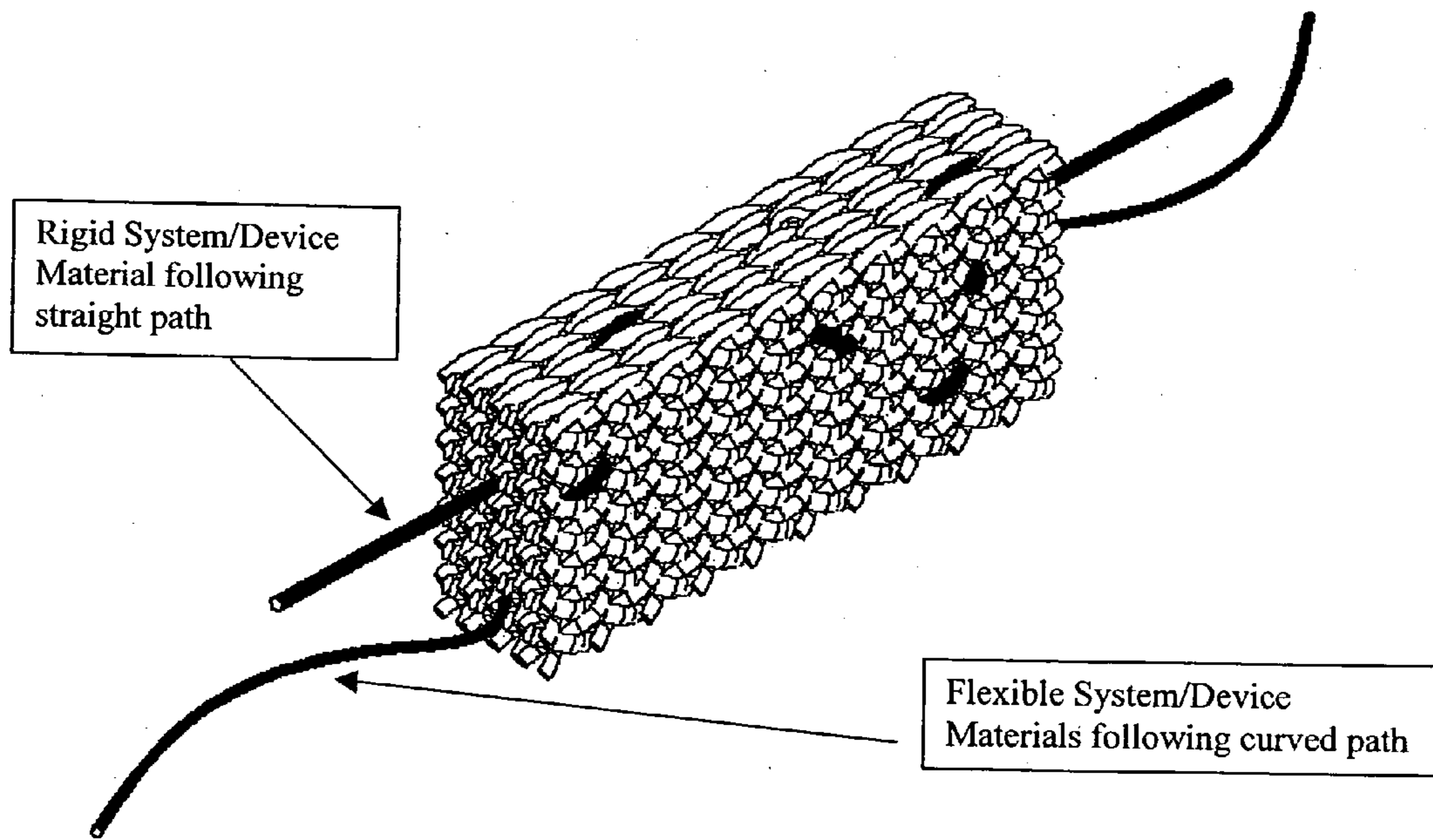

Figure 22

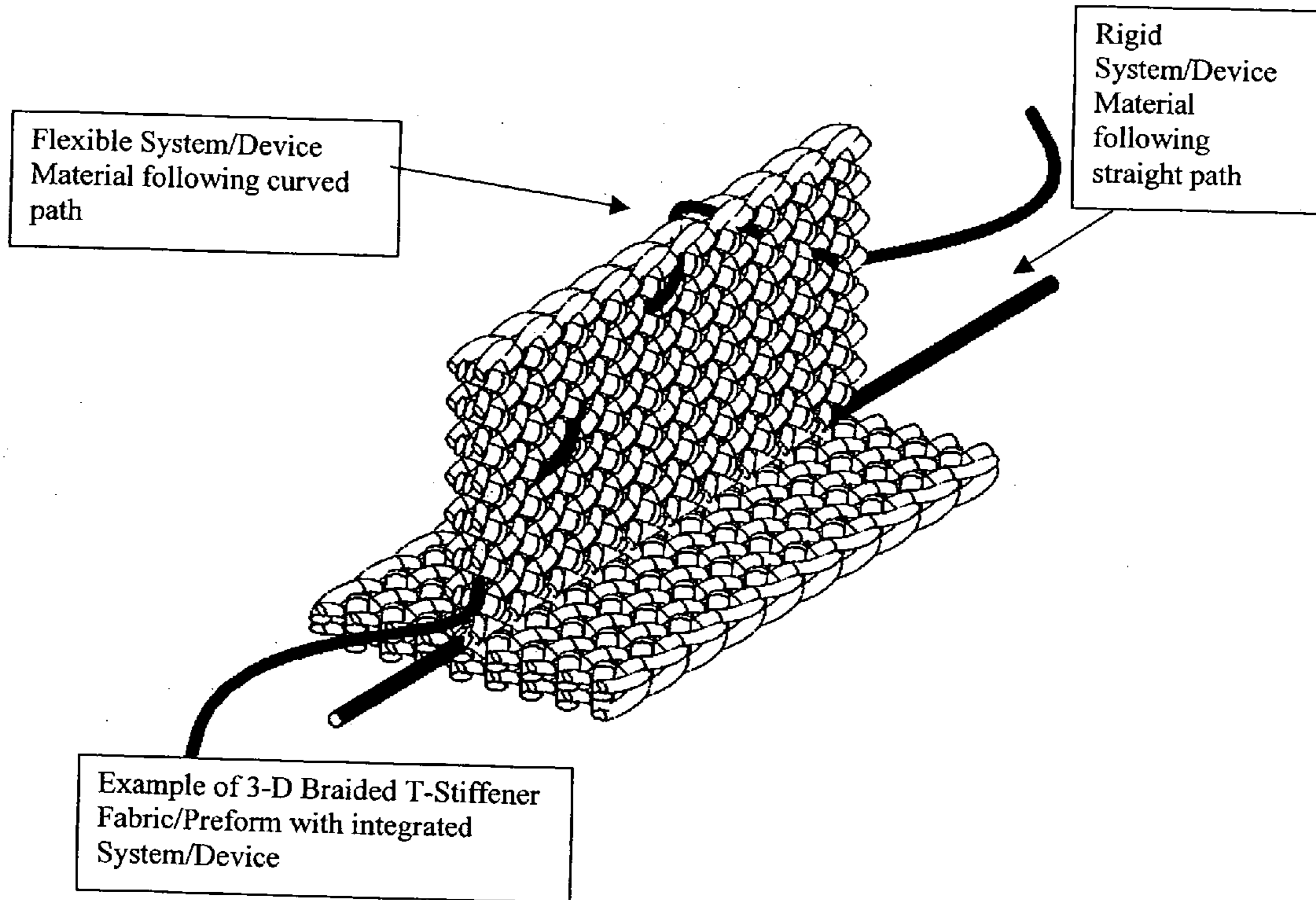

Figure 23

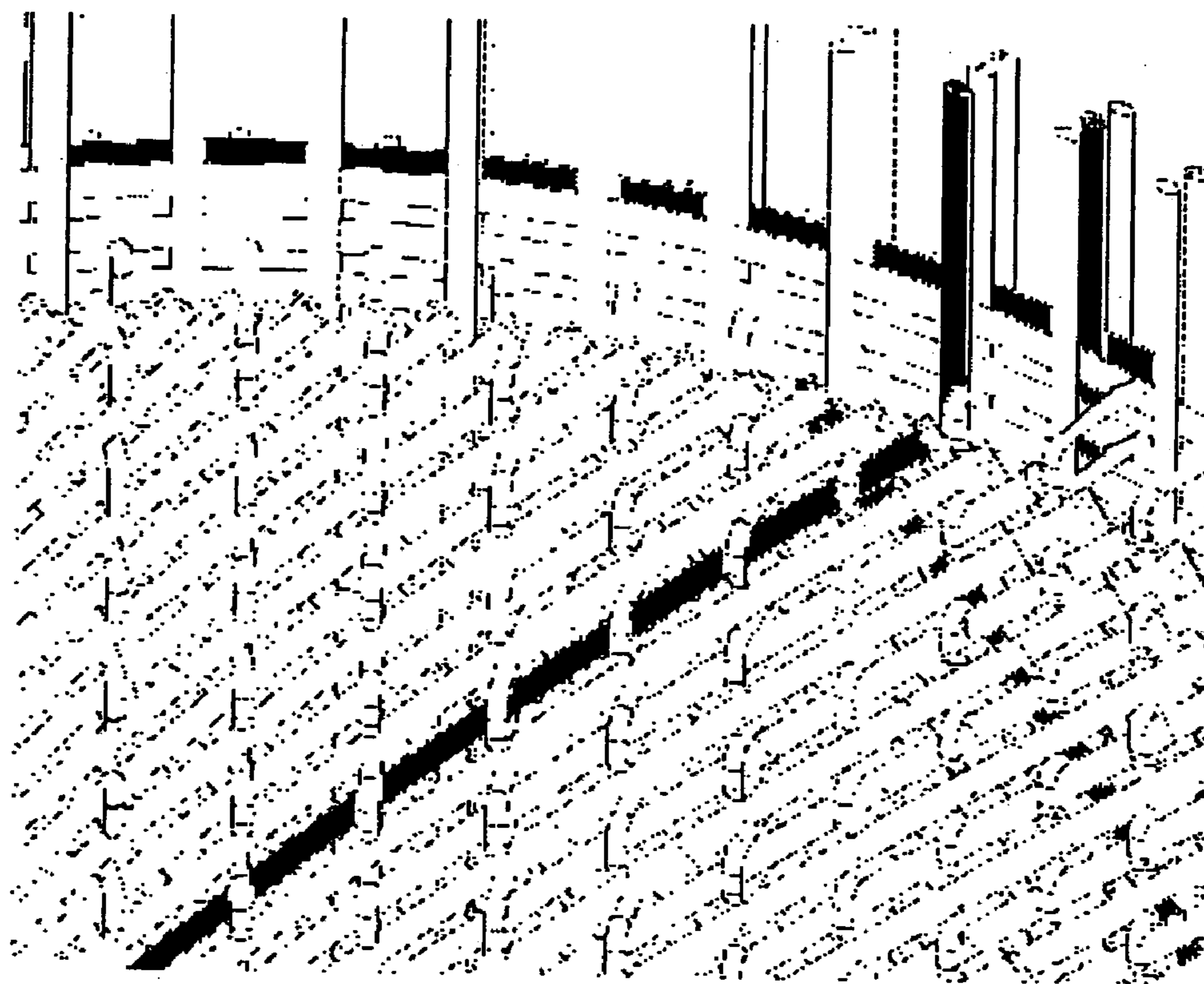

Figure 24

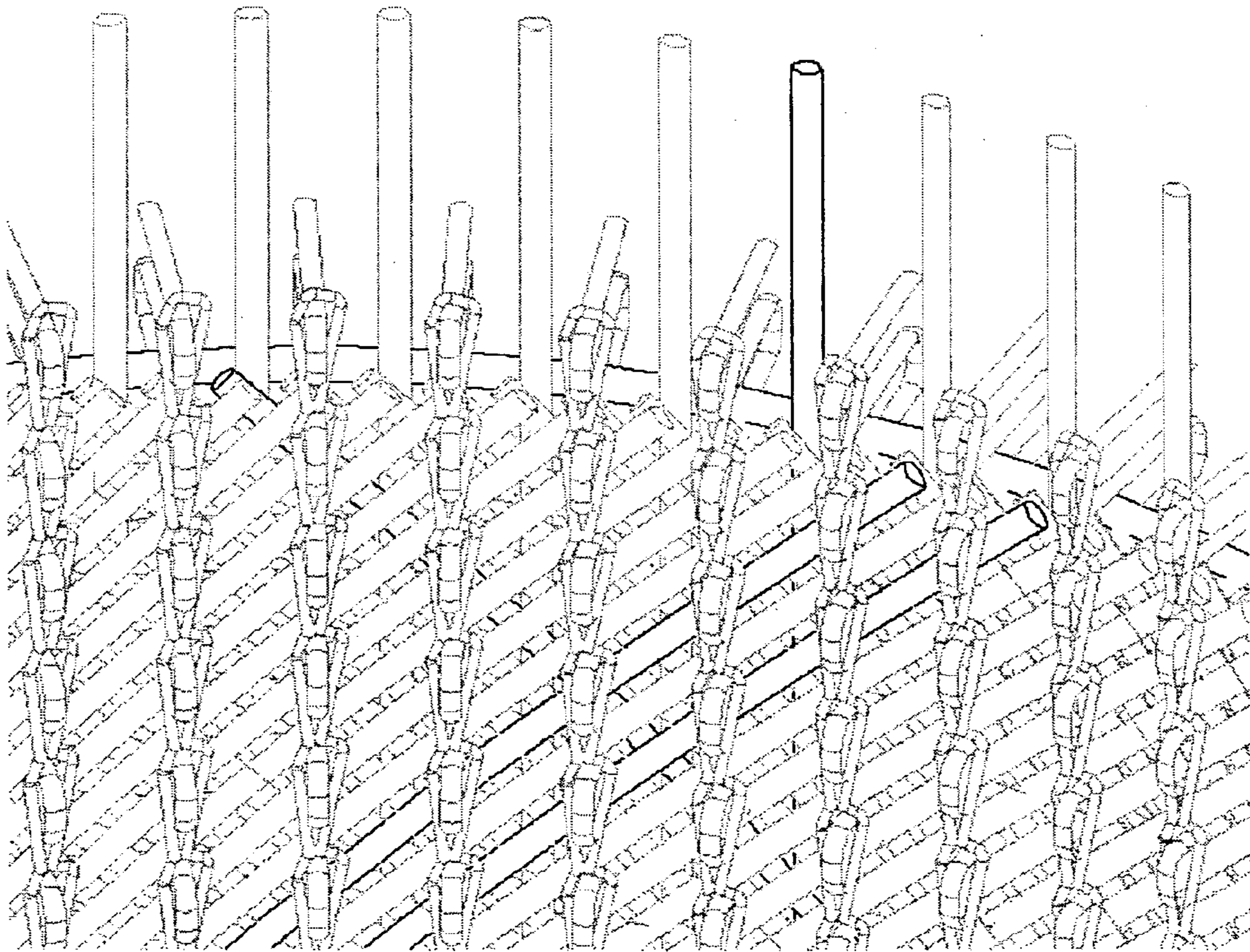

Figure 25

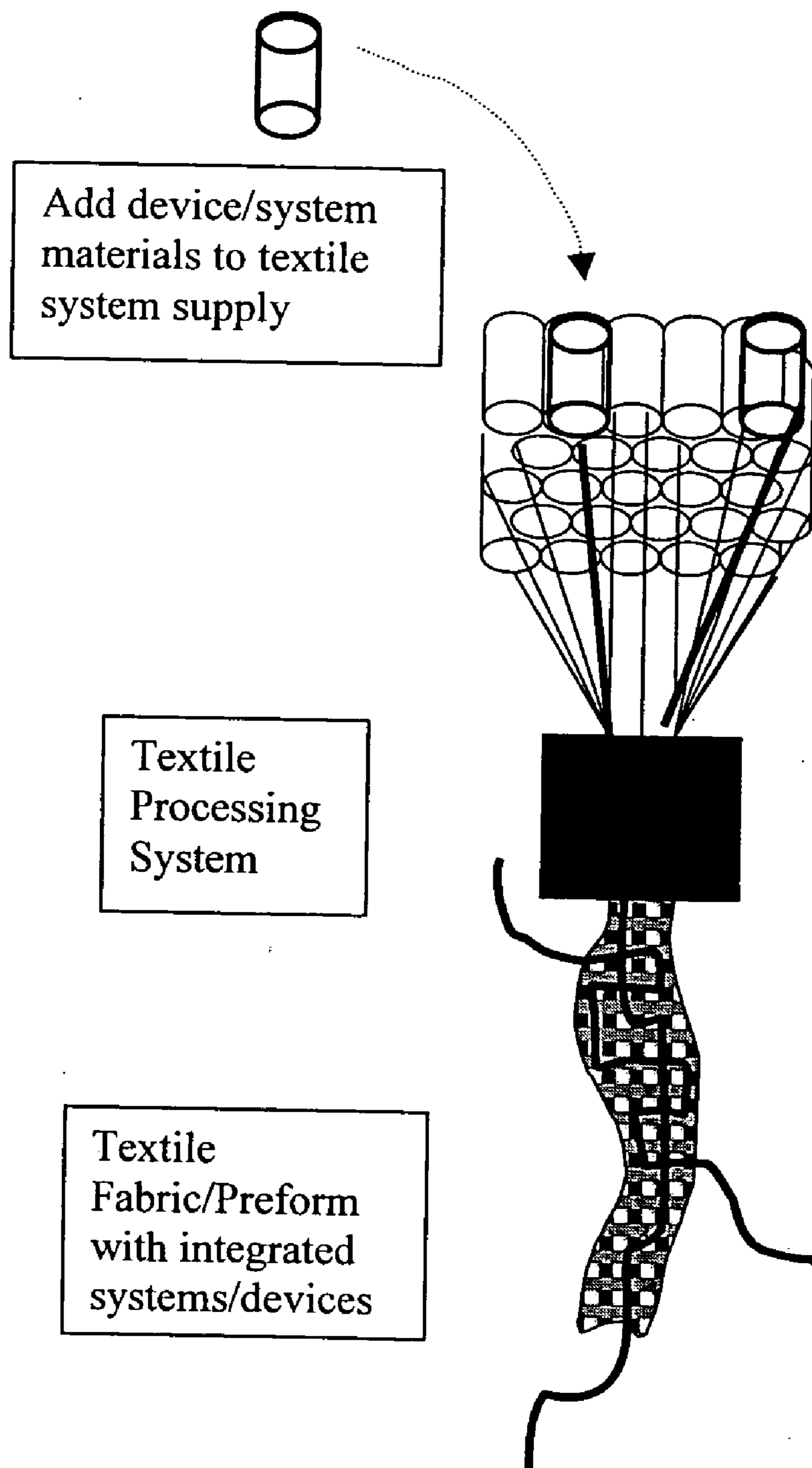

Figure 26

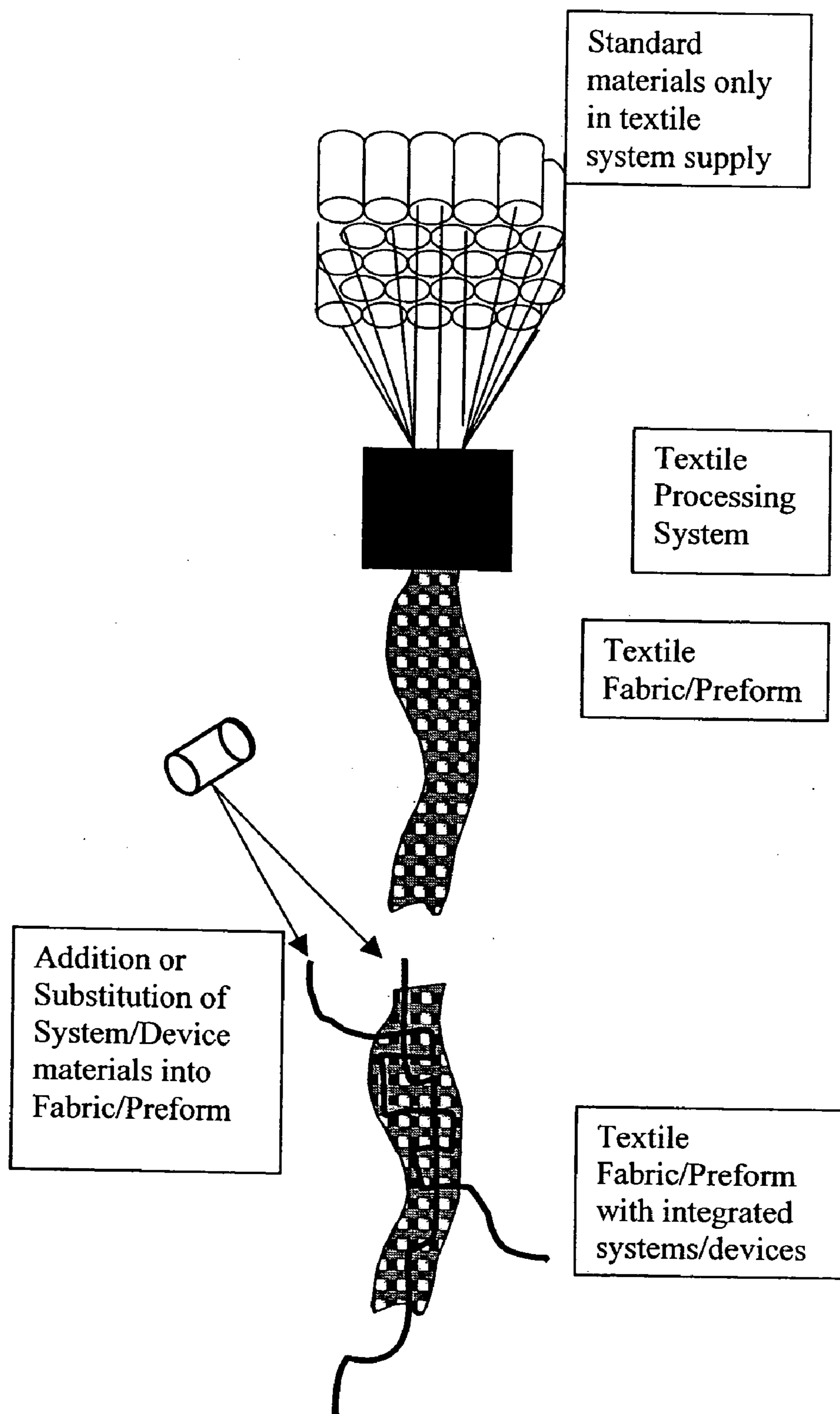

Figure 27

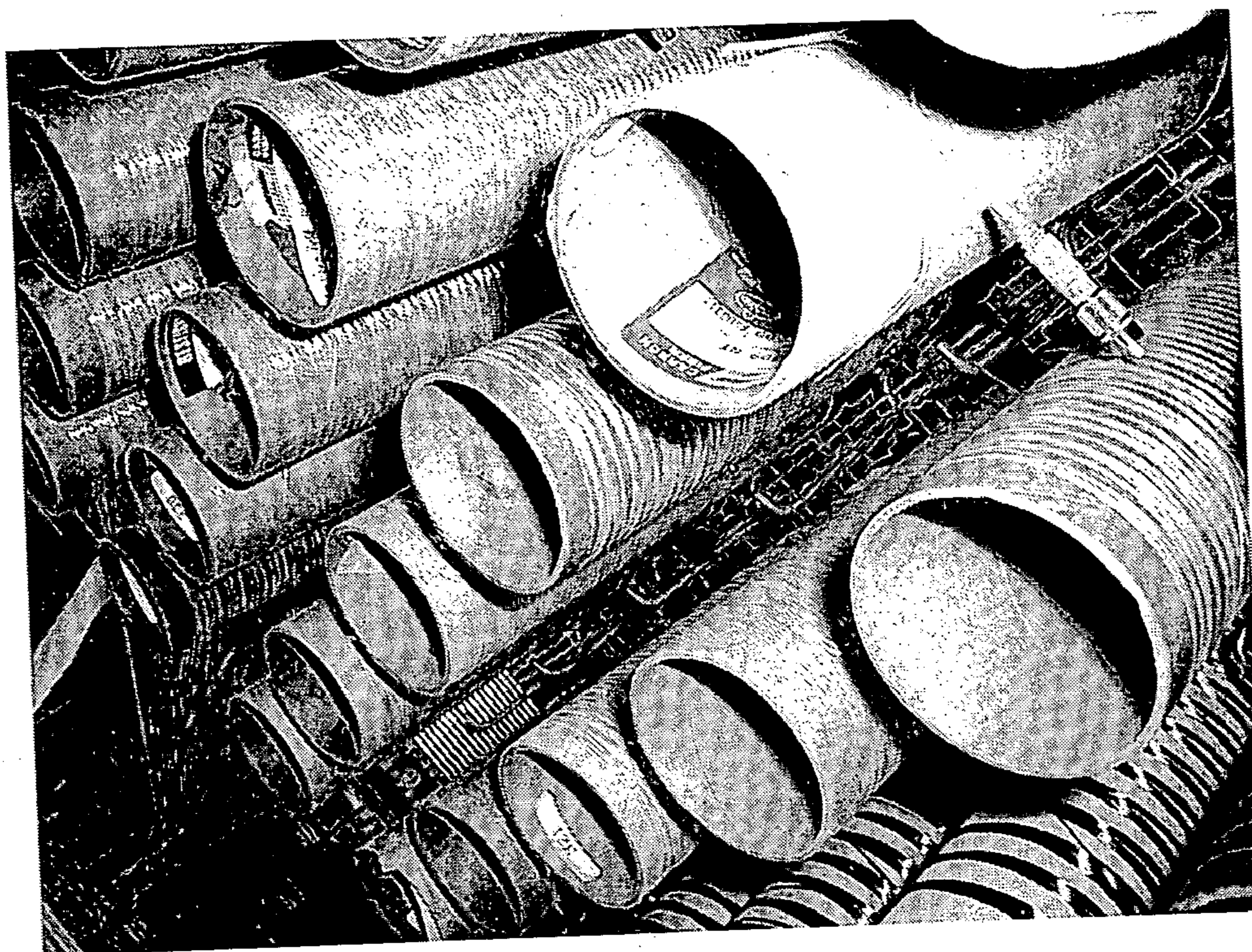

Figure 28

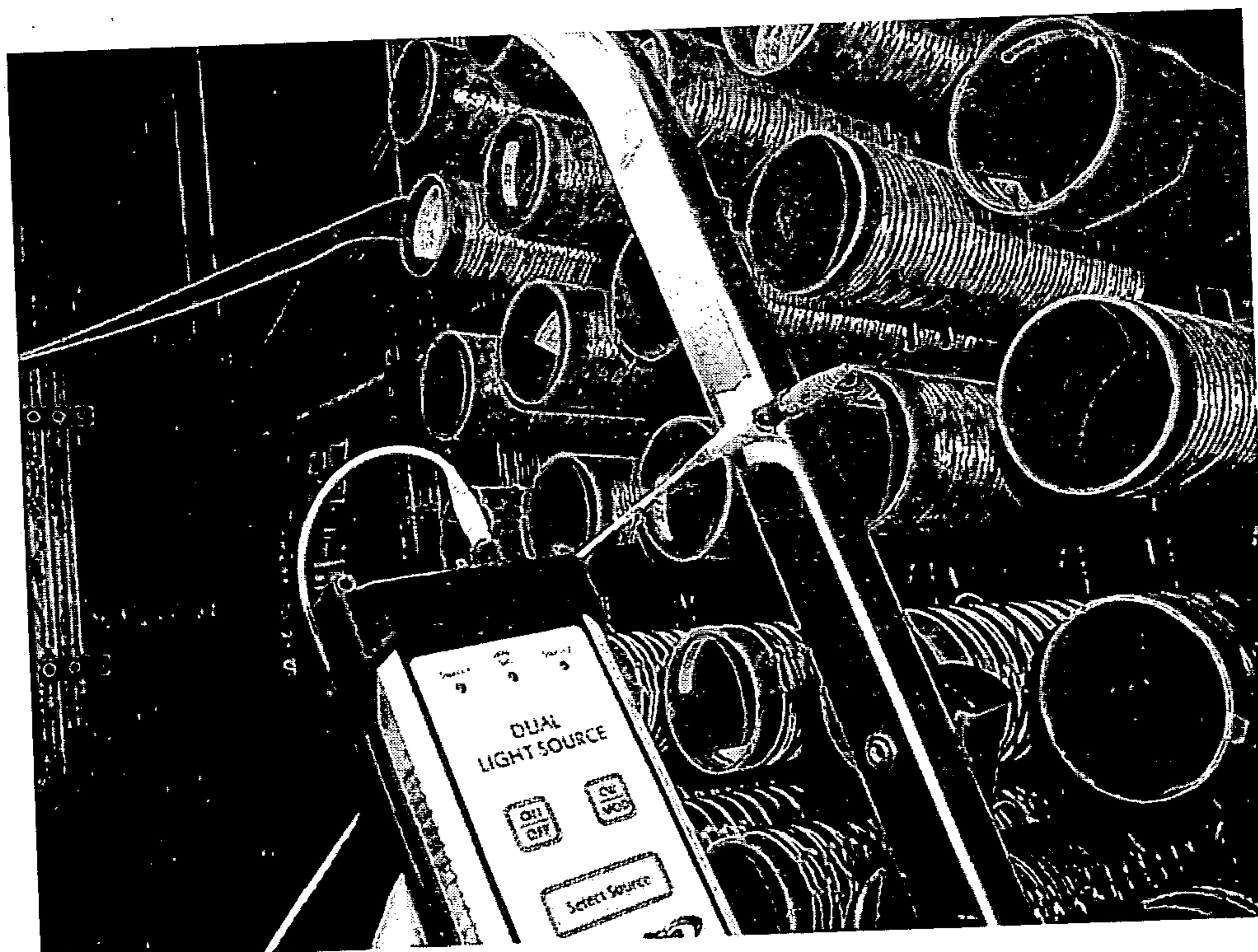

Figure 29



Figure 30

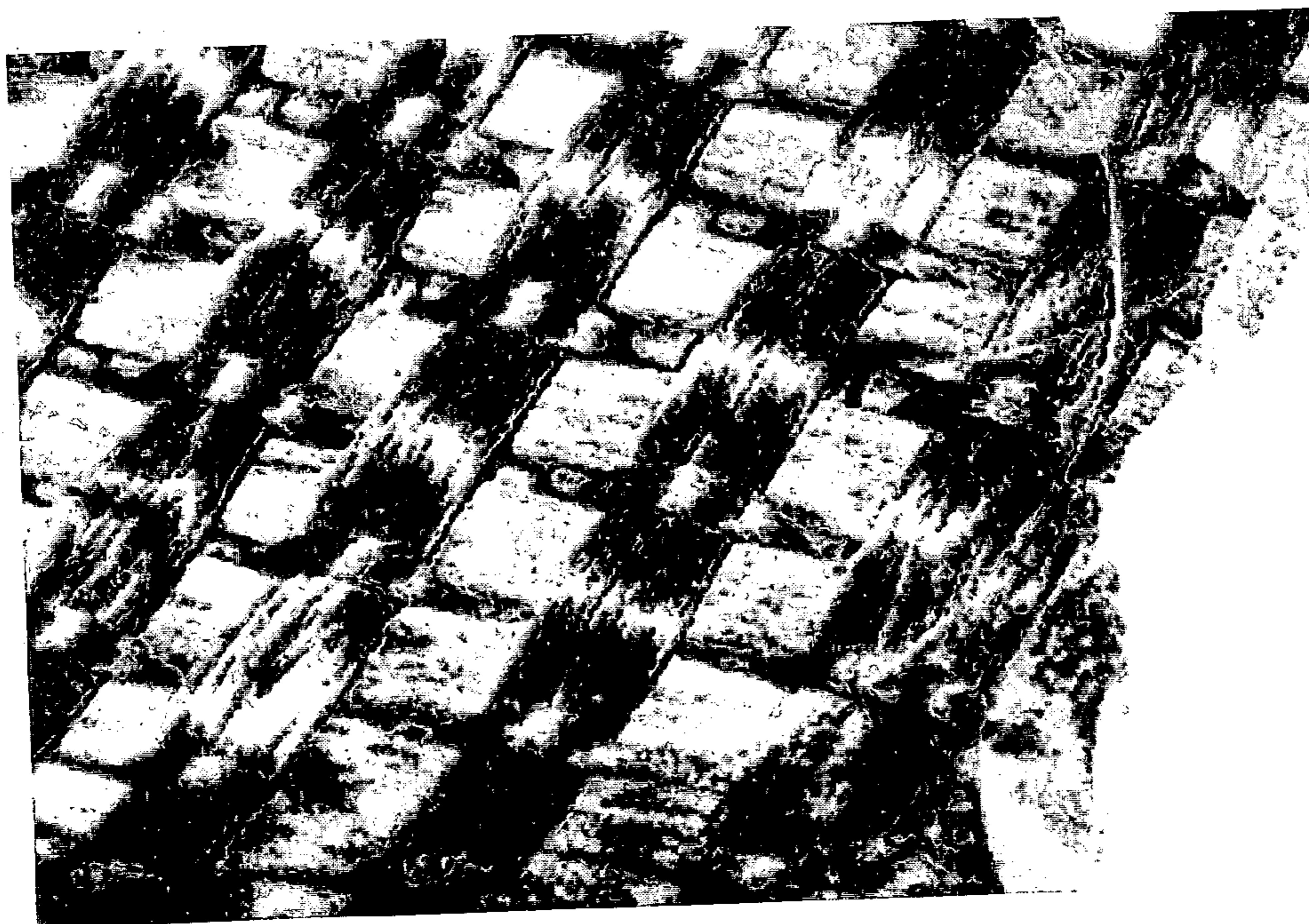

Figure 31

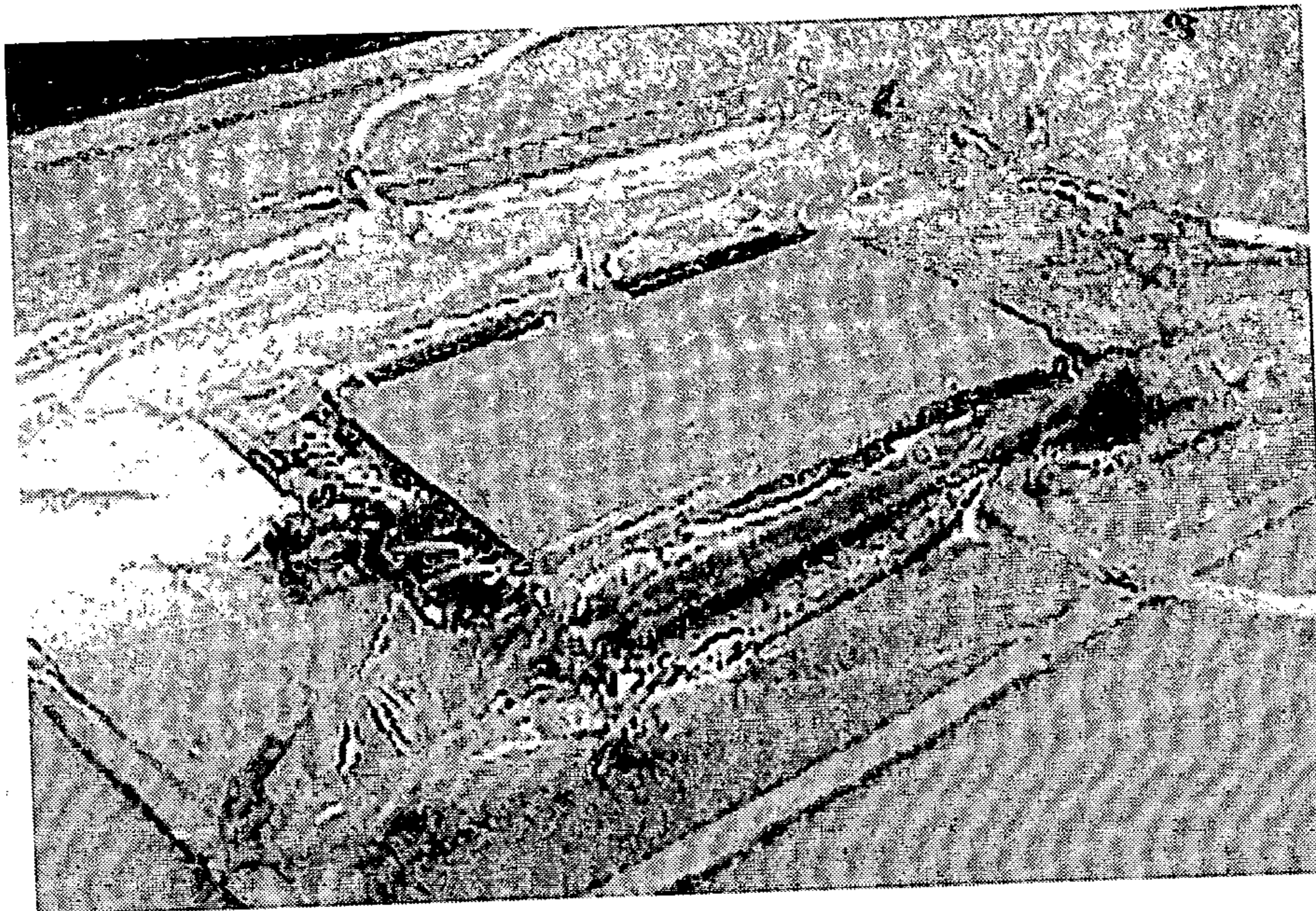

Figure 32

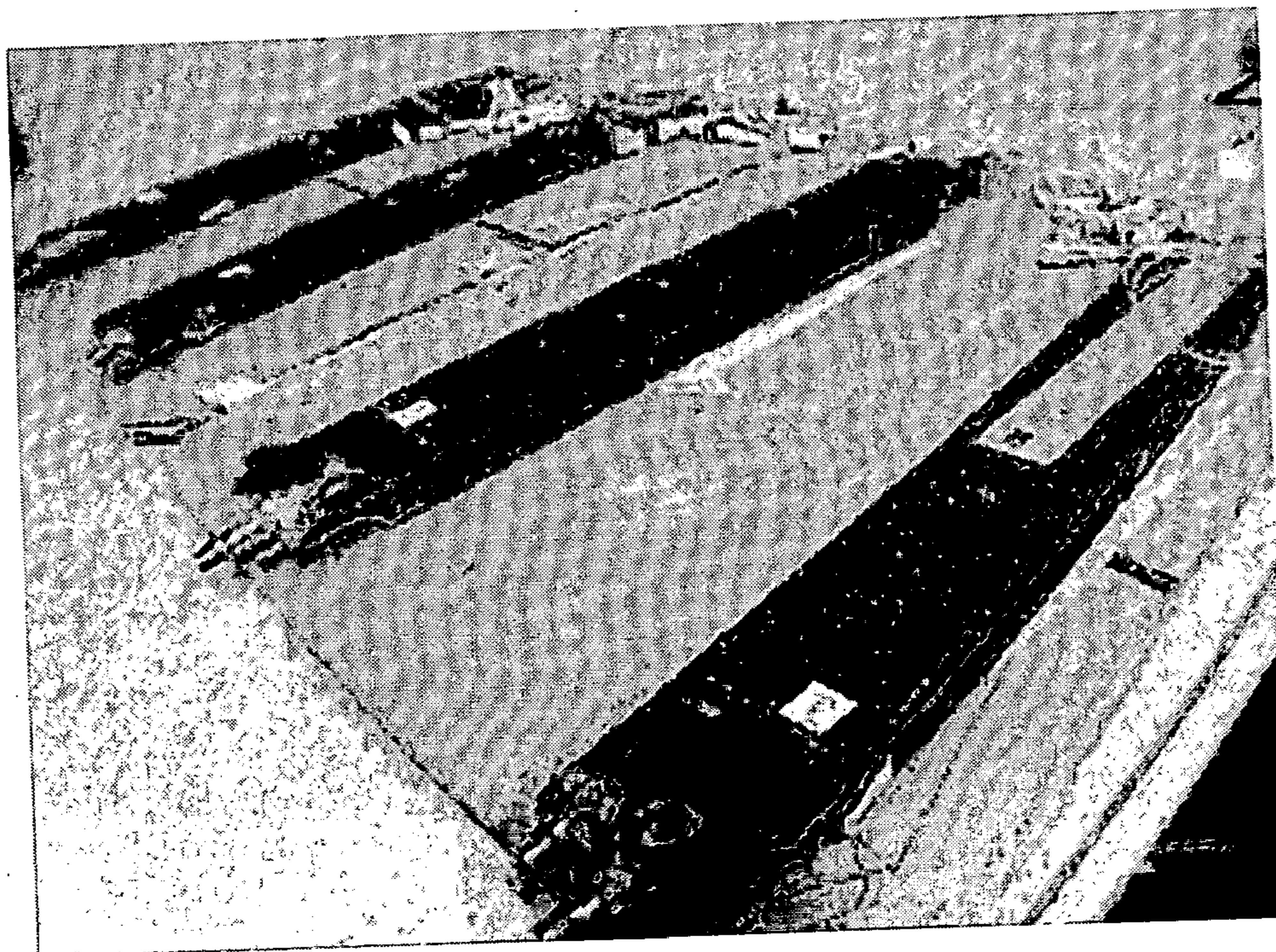

Figure 33

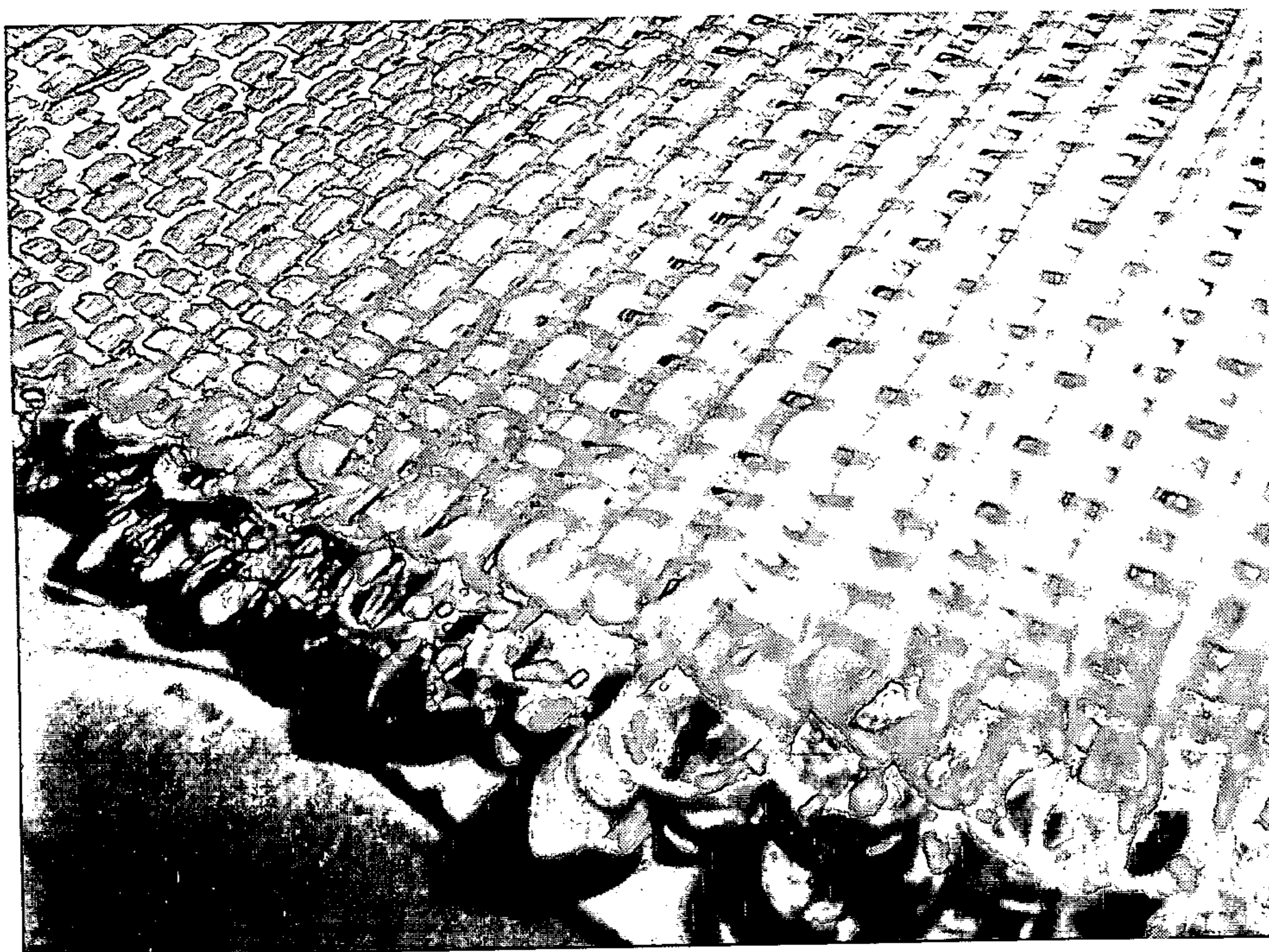

Figure 34

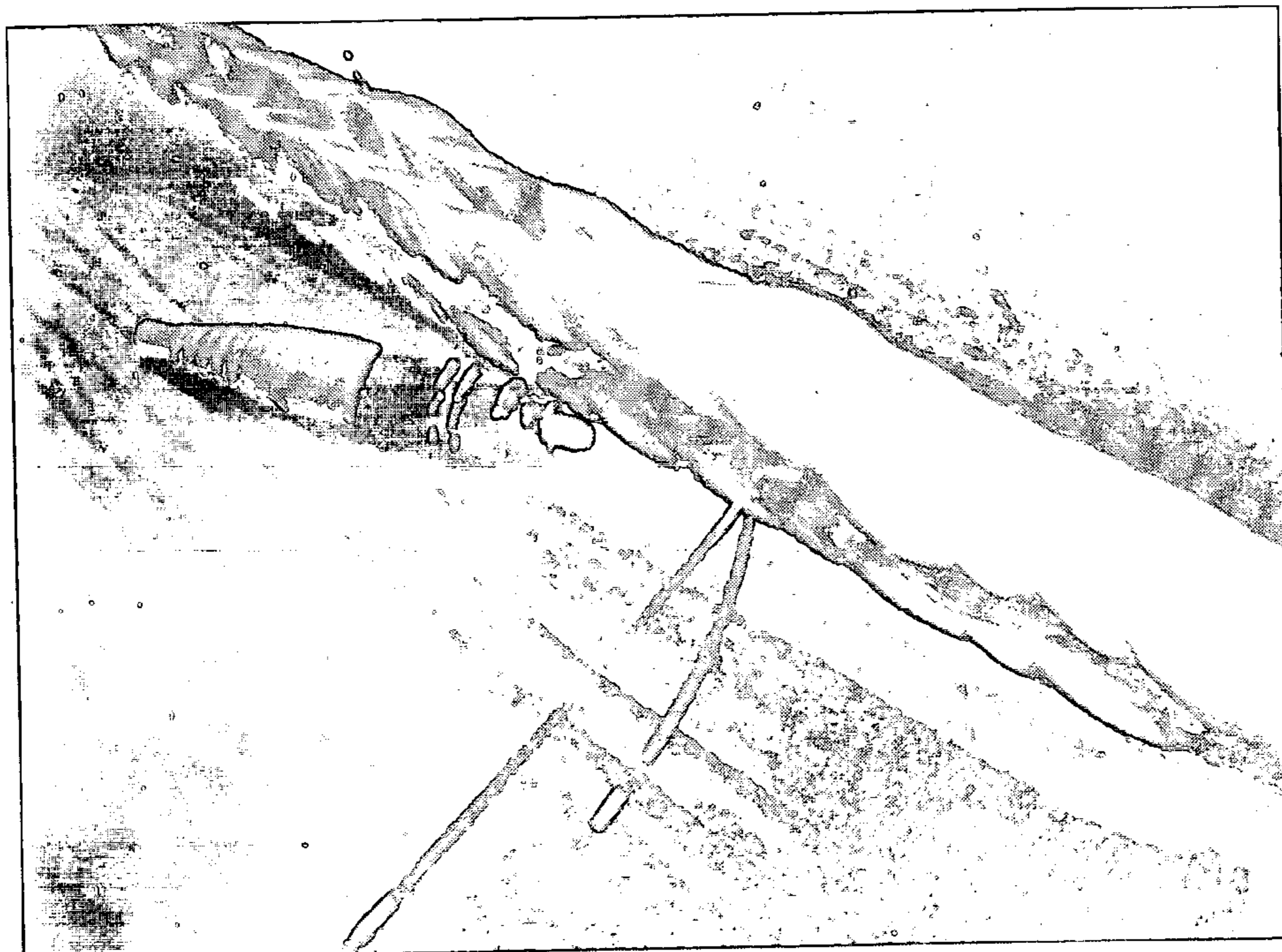

Figure 35

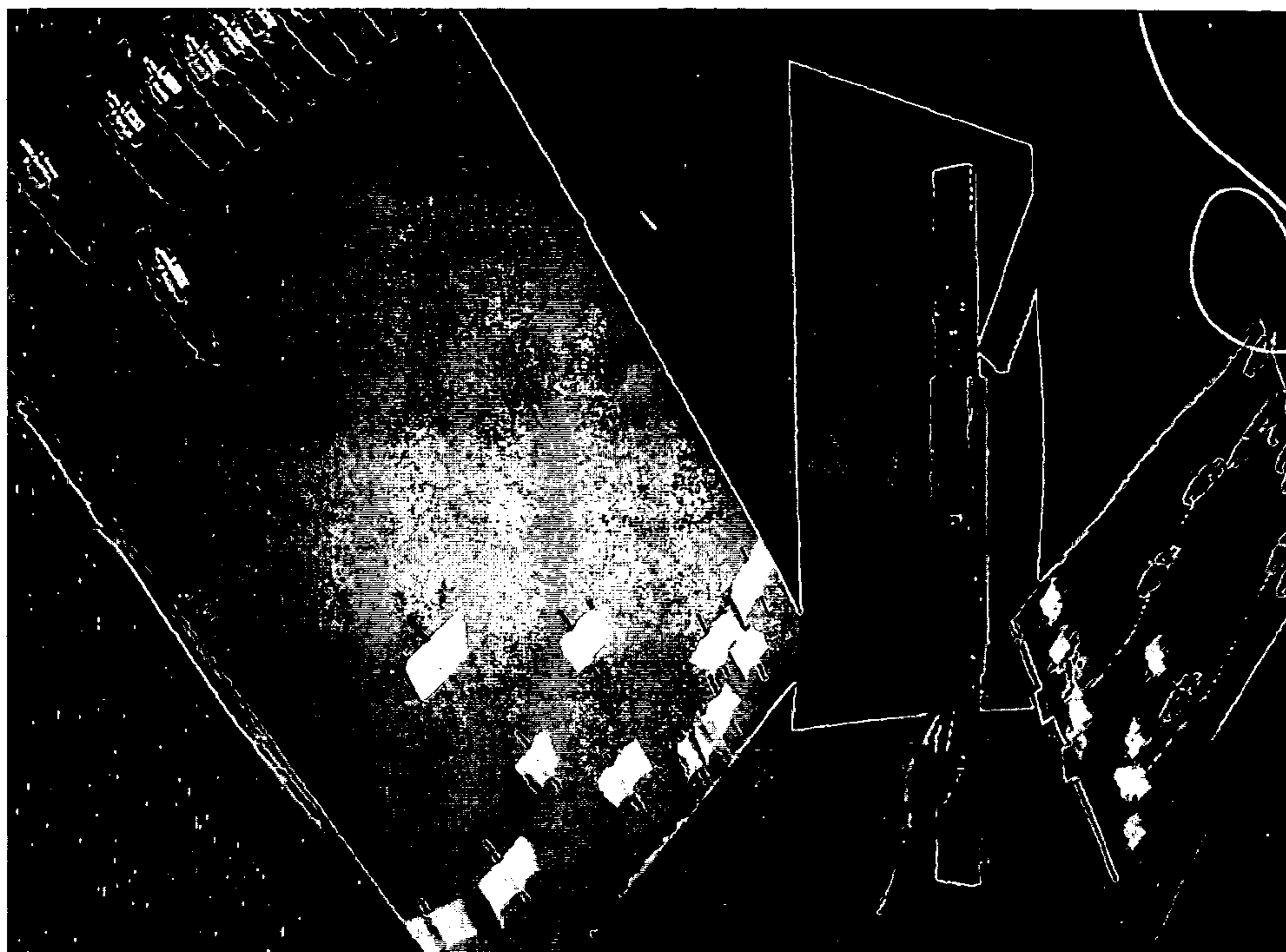

FIGURE 36



FIGURE 37

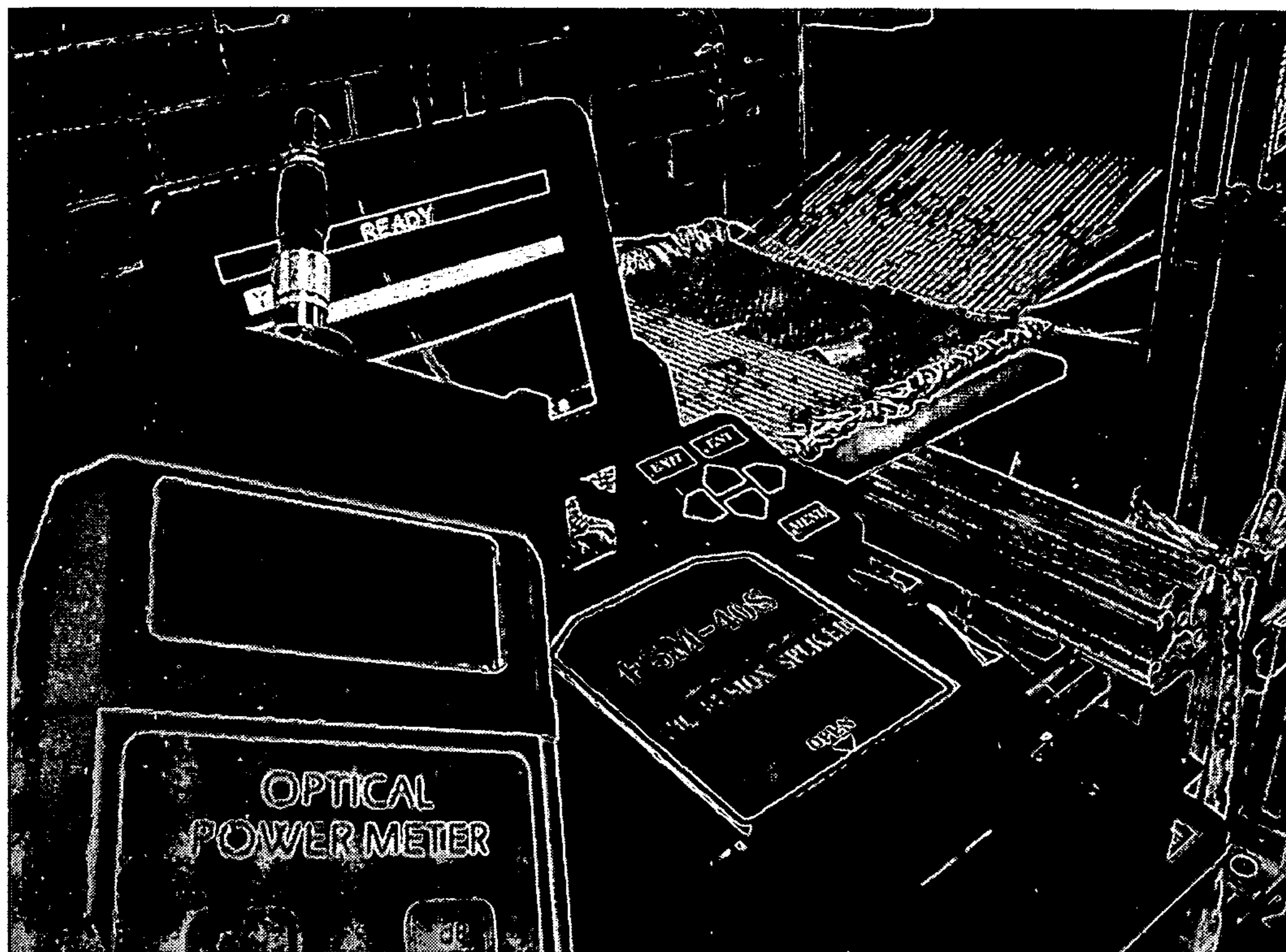

FIGURE 38

3-D FABRICS AND FABRIC PREFORMS FOR COMPOSITES HAVING INTEGRATED SYSTEMS, DEVICES, AND/OR NETWORKS

BACKGROUND OF THE INVENTION

[0001] (1) Field of the Invention

[0002] The present invention relates generally to fabric materials and, more particularly, to fabric preforms used for composites further including sensors, devices, and/or networks.

[0003] (2) Description of the Prior Art

[0004] Composites are materials formed from a plurality of components combined to form an integral structure. Typically, fabrics referred to as preforms are used within a composite structure provide a supporting framework for the composite, with a resinous material added thereto for filling interstitial regions and for providing a more amorphous component for transforming an otherwise non-stiff fabric preform into a rigid component for further shaping, machining, or other processing. The name "fiberglass" is a common slang term for one such composite material, but many other composite materials employ fabrics as preforms, including metal matrix, and carbon or ceramic matrix composites.

[0005] Prior art composites are known to employ sensors, devices, and/or networks for the purpose of sensing fatigue, failure, changing conditions, and the like and are generally referred to as "Smart Structures", or "Smart Materials"; however, in all cases known at the time of the present invention, any such sensors, devices, and/or networks were added or incorporated into the composite at or after the formation of the composite itself, i.e., they have not been included in the fabric preform prior to composite formation in any case. Further, such sensors, devices, and/or networks were added or incorporated into three-dimensional fabrics.

[0006] "Smart Structures" instrumented with a variety of sensing and/or actuation systems and devices have been one of the major focuses of science and engineering in the last two decades. They continue attracting great interest, which is primarily motivated by the fast growing capabilities of modern microelectronics and new structural materials which, in combination, enable development of the miniature, fully integrated in the structural material, multifunctional in-situ diagnostic and real-time control means. Typically, a smart structure, which is commonly associated with a vehicular, civil, marine, or other critical structural member, contains multiple attached or embedded sensor and/or actuator elements and some hardware and software for collecting, analyzing and storing information regarding the strain, temperature, damage, cracks, delamination, and other parameters characterizing structural integrity of the airframe. For smart structures to be relied on for mission or flight critical decision, the above flight critical characteristics must be continuously monitored, and structural integrity should be assessed in real time. Accomplishing this very complex task requires, in the first place, to reliably integrate and interrogate a large number of individual sensors distributed over the structure, as well as the means to receive data from them.

[0007] Various three-dimensional fabrics are often used as reinforcement of composite materials and as such are referred to as preforms. These fabrics may utilize both

flexible and rigid elements ranging from staple cotton yarn to solid ceramic wires or rods, and may be usefully employed in both their fabric states, or further processed as within composites, and as such no major distinction is made here between the terms "fabric" and "preform", whether extremely flexible as with a fine insulation fabric or rigid as with a structural wire grid formed with rigid rods. The plurality of controllably isolated or joined fiber or tow layers formed in 3-D fabrics provide particularly valuable opportunities, well beyond that of 2-D fabrics, for the development of elaborate functional systems, circuits, or networks as is so often done with multi-layer integrated circuits or multi-layer hydraulic manifolds. The very regular, inherently periodic nature of 3-D orthogonally woven and other 3-D fabrics, which are mentioned here as examples, allows them to perform functions similar to those of 3-D grids, arrays or networks. Examples of such functions include phased array emission/detection, shielding or refraction or diffraction of a known wavelength, damage and delamination detection, resin flow and cure rate control, acoustic emission signal sensing, active control of shapes, vibration suppression, supply or transmission of fluids to mention a few.

[0008] Optical fibers and sensing devices associated with them are one desirable means for producing smart structures. Optical fibers are available in small diameter; they are flexible, relatively light, relatively strong, relatively inert to environmental degradations, are not affected by electromagnetic influence, carry no electrical current. They can be quite easily adhered to surfaces of materials like metals, ceramics, plastics, composites, or embedded within thereof. When applied to composite structures in the past, optical fibers have been commonly bonded to the exterior or embedded between layers of prepreg without adversely affecting structural integrity. The optical fiber can be embedded in any curable, moldable, or laminated composite material without significantly disrupting the regular manufacturing process. While embedded into the structure, optical fibers neither significantly affect the mechanical characteristics of the composite nor concentrate mass at a particular location along the structure. Advantages of conventional fiber optic strain sensors over conventional electromagnetic strain gauges include simplicity, low cost, insensitivity to electromagnetic interference, immunity to electrical potential differences, operability over wide temperature ranges and operating environments, end use of simple and low-cost electronics. Besides, the use of fiber optics to replace conventional electric wires reduces the intensity of propagating electromagnetic waves, which results in reduced detectability of the system/device and interference with on-board computers.

[0009] A large variety of fiber optic sensors have been developed and are currently in use. Those include displacement, strain, temperature, pressure, moisture, wear, acoustic, magnetic, rate of rotation, acceleration, electric, electric current, trace vapor sensors to mention a few. The sensors may be adapted to modulate the light in different ways so as to encode multiple signals. For example, different characteristics of interest may be encoded by intensity, by frequency, or by phase. The two major types of fiber optic sensors are either phase modulated or intensity modulated sensor devices. Phase modulated fiber optic sensors may be characterized by their required use of coherent light sources, single-mode fibers and the need of relatively complex opti-

cal and electronic circuitry. This type sensor applications depend primarily upon force field induced length changes and strain induced refractive index changes, which are the cause of phase shifting as the light travels through the sensing length of the optical fiber; this can be detected using an interferometer apparatus. The intensity modulated type fiber optic sensors, on the other hand, depend primarily on an optical source of constant intensity, which is ordinarily acted upon by an external force field.

[0010] Numerous fiber optic sensors known from the prior art can be categorized in many different ways. One of them—segregating sensors into extrinsic and intrinsic, is of particular interest in the context of present invention. Two sensor types belonging to either of these groups, namely Extrinsic Fabry-Perot Interferometric (EFPI) sensors and Bragg Grating (BG) sensors are used here for the reduction to practice demonstration. It is well established that EFPI sensors have much lower thermal sensitivity, also sensitivity to lateral strains, to dynamic perturbations (mechanical vibration, acoustic waves), and to magnetic fields than BG sensors. It is also believed that EFPI sensors are better suited for the use in hostile environments, which can be faced, specifically, when the sensor is exposed to the full manufacturing cycle of a composite material. On the other hand, an EFPI sensor (which is a complex device itself), after it is integrated in the composite material, has much higher potential to become a considerable local origin of disturbance than a BG sensor (due to the latter one is mechanically indistinguishable from its carrying optical fiber). Also to the advantage of BG sensors—a large series of them can be carried by a single optical fiber; it is much easier to embed/integrate BG sensors in the composite and simultaneously interrogate them under loading.

[0011] Present invention is related to engineered three-dimensional fabrics and fabric preforms for composite materials instrumented with fiber optic sensors and other types of sensing, actuating and information transmitting systems, devices and networks which can be suitably integrated in the said fabrics and fabric preforms. The said fabrics and fabric preforms are treated as the carriers of the said systems, devices and networks. From this viewpoint, the said fabric preforms, after being processed into composite materials and structures, become integral with them, together with their carried said systems, devices and networks.

[0012] In order to clearly identify the novelty of the present invention and its distinct place among prior art in the field, the following overview of the prior art in the field of composite materials and structures and textile fabrics with embedded/integrated fiber optic sensors is provided, including comments on their respective methods of their fabrication.

[0013] U.S. Pat. No. 4,221,962 teaches how an optical glass fiber is embedded in a composite laminate to monitor and detect the presence of moisture in the interior of the panel. According to the invention, the optical fiber is “sandwiched” between the plies during ply lay-up, becomes an integral part of the laminate, and as such goes through the laminate curing cycle.

[0014] U.S. Pat. No. 4,537,469 describes a reinforced structural member, which is composed from a plurality of high tensile strength optical fibers, arranged into at least two parallel layers and embedded in the resin material. Importantly,

all described optical fiber architectures in the invented composite are limited to two-dimensional woven architectures.

[0015] U.S. Pat. No. 4,581,527 describes a system consisting of a plurality of layers of optical fiber grids for detecting damage and assessing its location in laminated composite materials. The optical fiber grid system is implanted in a composite laminate during its fabrication and becomes integral with it. Each optical fiber grid includes two orthogonal series of optical fibers.

[0016] U.S. Pat. No. 4,603,252 also describes a plurality of light conducting fibers, which is included in laminated composite material. The light transmitting fibers are included, as at least one separate layer, in between adjacent structural laminas, importantly, in some regular pattern.

[0017] U.S. Pat. No. 4,772,092 describes method of measurement and detection of cracks and fissures in test objects (specifically, laminated composites), particularly under utilization of light conducting fibers, which will break in the instance of a crack or fissure. In the preferred embodiment of this invention, it is described that several light conducting fibers are either inserted within the layers of regular fibers by replacing some of the regular fibers, or light conducting fibers are placed in between adjacent layers of regular fibers in a mesh. After that the respective layers are put together and impregnated in resin. The detailed description of the invention and illustrative material do not indicate that any type of fiber architecture other than a unidirectional fiber placement or generic 2-D woven architecture, has been intended in the invention.

[0018] U.S. Pat. No. 4,836,030 describes the method of embedding a plurality of optical fibers in the composite material in pre-determined two-dimensional configuration (a serpentine pattern, specifically). Detection of light passing through any given optical fiber indicates that the composite is free of damage in the area along the extent of that optical fiber; however, integrating optical fibers within a fabric structure that is a 2-D woven structure or the like, where fiber paths are typically non-orthogonal and not substantially straight due to necessary crimping, prevents the integration of these fibers within the fabric itself. A layer of film adhesive is formed, in which optical fibers are embedded. The film adhesive layers are incorporated in composite laminate at the time of its manufacture. Optical fibers, embedded by this approach between different plies of a laminate, provide information about damage formation through the thickness. Two examples of practical manufacturing procedures that resulted in successful manufacturing of composite sandwich and laminate structures with two types of embedded fiber optics, are comprehensively described in the patent. Based on experimental results, it has been concluded that the subject method pinpoints the location of delamination as well as identifies the location of other types of damage. No fabric-type architectures of any kind were described in the patent in the context of embedded optical fiber configurations.

[0019] U.S. Pat. No. 4,891,511 describes a microbend sensor device, which contains a plurality of braided fibers with at least one of them being an optical fiber. The “braid”, as it is referred to in the invention, is a generic strand of several intertwined fibers, including one or more optical fibers, without any reference to specific braided fabric architecture or equipment it can be produced on.

[0020] U.S. Pat. No. 5,023,845 teaches a new testing technique, that has been conceptualized and experimentally validated, and is based on the utilization of optical fibers embedded in composite laminate. No unconventional ways or patterns of embedding optical fibers between layers of a laminate were described in this invention.

[0021] U.S. Pat. No. 5,029,977 describes an optical fiber mounting system, which includes a two-dimensional rollable woven fabric “supporting device” and an optical fiber integrated in the said supporting device. One suggested approach of integrating the optical fiber into said supporting device is to weave the fiber in (as a weft or warp thread). The alternative approach is to incorporate the optical fiber by laminating it between the sheets of the structural fiber fabric. Further, the fabric containing the optical fiber is incorporated into the composite structure during the latter’s manufacture. Attachment of the optical fibers to the structure after its fabrication is another embodiment. Significantly, the patent only suggests the use of 2-D woven fabrics in the fabrication of the invented mounting device.

[0022] U.S. Pat. No. 5,118,931 describes a fiber optic microbend sensor that detects changes in a material caused by deformation of an optical fiber bonded to the structure.

[0023] U.S. Pat. No. 5,182,449 describes a sensor system for structural composites, which includes a plurality of optical sensors integrated with the structure, i.e., the sensor can be either attached to the surface of the structure or embedded within a composite structure.

[0024] U.S. Pat. No. 5,338,928 describes the method to control vibrations within ceramic matrix composite (CMC) or metal matrix composite (MMC) by applying an excitation voltage to array of piezoelectric actuators mounted on the surface of the structure and driven in response to the phase shift of monochromatic light transmitted through a grid of optical fibers embedded within a composite material. The optical fibers, as described in the invention, can be arranged in an orthogonal two-dimensional grid pattern for detecting strain along two mutually orthogonal axes. Once the fiber architecture in the structure is established, an optical fiber capable of withstanding high temperature environments can be inserted into the structure prior to chemical vapor infiltration in the case of CMCs or prior to plasma spraying, foil-fiber-foil construction or other processing method applicable to MMCs. Fiber optic sensors, usable for the purpose of this invention, can be gold-coated silica or sapphire fibers, which can withstand the CMC or MMC processing temperatures. It is important to note, however, that no intent of integrating optical fibers into textile preforms can be found in the patent description.

[0025] U.S. Pat. No. 5,493,390 describes a compact and integrated system for the real time in-service strain monitoring. The system includes Bragg grating sensors and planar tunable opto-acoustic filter for analyzing the optical signal. The optical fibers can be embedded in or bonded to the structure.

[0026] U.S. Pat. No. 5,515,041 describes a concept of rotor shaft made of composite material with integrated fiber optic sensor and a resonant detector circuit for detecting sensor output, which is also integrated within the structure. However, the invention does not teach any practical means how to embed the aforementioned sensors into a composite rotor shaft, or how to integrate the sensing apparatus.

[0027] A different type of fiber optic sensor application, which is outside the area of diagnostics and health monitoring of composite materials, is described in U.S. Pat. No. 6,381,482. A fabric or a garment structure comprising a “comfort component” serving as the base of fabric, and an “information infrastructure component” integrated within the comfort component, is the object of this invention. The information infrastructure component may comprise a plurality of sheathed optical fibers, which purpose is to detect ballistic projectile penetration. The multifunctional fabric of this kind, incorporating the two aforementioned components, is suggested to be manufactured as a two-dimensional woven or knitted fabric. In addition to the aforementioned optical fibers, an “electrical conductive component” can be integrated within the said 2-D woven or knitted fabric. The latter component may comprise metallic fibers, intrinsically conductive polymers, doped fibers, and combinations thereof. The electrical conductive component is aimed at transmitting information from sensors to monitoring devices.

[0028] Conducting rigid or flexible systems incorporated into 2-D fabrics or embedded into polymers and composites have been used for a variety of other applications. One of them is described in U.S. Pat. No. 4,795,998, where the invented sensor array aimed at sensing pressure was constructed as a grid of flexible conducting elements incorporated in a 2-D woven fabric. No indication can be found in the patent toward the utilization of any kind of 3-D fabric architecture.

[0029] U.S. Pat. No. 5,103,504 describes textile fabric and clothing made thereof, which comprises cotton fibers and 6-10 microns in diameter stainless steel fibers blended together and spun into mixed yarn. The steel fibers have weight content 10-15% in the mixed yarn. The purpose of such fabric, which is a two-dimensional according to the invention description, is to provide efficient shielding against microwaves and other types of electromagnetic radiation to which, in particular, the hospital personnel is exposed when operating electro-medical equipment.

[0030] U.S. Pat. No. 5,210,499 describes the method of polymeric resin flow monitoring and cure rate monitoring by the use of sensors as integral component of the monitored system. The sensor threads may be woven into the fabric, however illustrations to the patent clearly indicate that only 2-D weaving was intended within the scope of this invention.

[0031] Another broad and fast growing area of smart structures is related to embedment/integration of piezoelectric actuators and/or sensors into composite materials and structures. If instrumented with piezoelectric fibers, ribbons, tapes, films, or other suitable shapes devices, smart composites may perform both actuation and sensing functions in a closed-loop configuration. The piezoelectric fiber composites are highly tailorable to specific needs by selecting appropriate mechanical, actuation and sensing properties of piezoelectric fibers and matrices, similarly to the case of conventional composites, namely through selecting optimal fiber diameter, mechanical and piezoelectrical characteristics, fiber spacing and orientation, as well as matrix mechanical and piezoelectric properties. The diameter of piezoelectric fibers can be selected from a broad range—typically between 5 and 200 microns. A smaller diameter

fibers may be preferable in textile applications, due to they provide more flexibility, higher strength and, consequently can be easier processed into the fabric. Besides, smaller diameter piezoelectric fibers can operate at a lower voltage. Piezoelectrical fibers may be continuous or available in short fragments. The fiber geometry can also be varied.

[0032] The most efficient actuator materials are piezoelectric ceramics, such as zirconate titanate (PZT), and electrostrictive ceramics, such as lead molybdenum niobate (PMN). Unfortunately, most of the ceramics are very brittle (have very low ultimate strain characteristic) and have a large positive coefficient of thermal expansion. These features create serious problems with embedment of piezoceramic actuators/sensors in polymer matrix composites. When a graphite fiber/epoxy resin composite, in particular, is fabricated with embedded piezoceramic elements at elevated temperatures, tensile thermal stresses are induced in the piezoceramic element, which can cause cracking and degrading functionality. Another popular piezoelectric material is polyvinylidene fluoride (PVDF) available as a thin film. More information on piezoelectric materials and their applications can be found in U.S. Pat. Nos. 5,305,507; 5,869,189 and other literature. Besides, as mentioned in the latter patent, shape memory allows can be provided in fiber form, arranged in parallel arrays, and embedded in polymer matrix to form a smart composite. Such composite can be actuated by heat provided in the direction transverse to the fiber axis by, for example, a resistive metal layer coated on the composite.

[0033] Next a brief overview is provided of the prior art in the area of piezoelectric actuators/sensors that is relevant to the present invention.

[0034] U.S. Pat. No. 4,400,642 describes a laminated structural device, which may be, generally, a combination of (i) layers made from a piezoelectrically active, non-conductive matrix material with a plurality of embedded electrically conductive fibers and (ii) layers made from an electrically conductive matrix material with a plurality of embedded piezoelectrically active fibers. The patent does not teach about using textile preforms as reinforcement for the invented laminated composites.

[0035] U.S. Pat. No. 4,849,668 describes a composite structural member, which includes multiple layers of graphite/epoxy composite with one or more embedded piezoelectric elements. In a preferred embodiment, the piezoelectric components are formed of a ceramic material. The composite laminate is fabricated by fitting the piezoelectric elements into apertures in epoxy-impregnated graphite fiber layers, laying-up the layers, and applying heat and pressure to cure the structure. Importantly, the piezoelectric elements intended for the embedment according to the invention are in the form of a thin film, which has two comparable dimensions, while its thickness dimension is about 60 times smaller than the other two. At the same time, that thickness with added insulation film was as large as total thickness of three prepreg plies, which asked to cut three plies in the fabrication process to make room for each piezoelectric element.

[0036] U.S. Pat. No. 5,195,046 describes a sensor module, which includes a plurality of piezoelectric transducers that convert mechanical motion experienced by the structure, into corresponding electrical signals.

[0037] U.S. Pat. No. 5,305,507 describes a piezoelectric actuator/sensor package and a method of embedding a ceramic actuator/sensor in a laminated structural composite, such as graphite/epoxy laminate. A ceramic actuator/sensor is first encapsulated in a non-conductive fiber composite, specifically fiberglass cloth and epoxy, which is an alternative to polyimide film Kapton suggested for analogous purpose in U.S. Pat. No. 4,849,668. Such a package prepared for embedment is generally planar and is placed in its selected location between layers of structural composite, and the laminate is cured at an elevated temperature.

[0038] U.S. Pat. No. 5,814,729 describes the system for in-situ delamination detection in laminated composites. Both the piezoelectric ceramic actuators and fiber optic sensors may be embedded between the layers of composite material during its fabrication. The embedded sensors and actuators are essentially placed within a plane between two layers of a laminate.

[0039] U.S. Pat. No. 5,869,189 describes composite materials aimed at actuating and sensing deformation and having a series of flexible elongated electroceramic (particularly, piezoelectric) fibers arranged in a parallel array and separated from adjacent fibers by relatively soft polymer. The composite also includes flexible conductive electrodes extended in the axial direction of the electroceramic fibers. The composite may also include arrays of fibers that are stacked in multiple layers along the thickness. The piezoelectric fiber composite is embedded in a laminated structural composite component and spans its entire length and width. The structural component can be formed by pre-forming the piezoelectric composite, placing it between the host layers, and then curing the whole laminate. Alternatively, the host layers and piezoelectric composite can be co-cured in a single step. The composition can also be pre-formed in a pre-impregnated form. The conductive electrodes are, preferably, in direct contact with carbon fibers of the structural composite. The electrode layers may be made of a thin polymer substrate with an ultra-thin layer of metal. In other embodiments, the principles set forth in the invention can be used with materials that rely on actuation phenomena other than the piezoelectric effect. Significantly, no fabric materials were intended for use in this invention; as such this patent teaches away from the present invention.

[0040] U.S. Pat. No. 6,006,163 describes an active damage interrogation system and method which utilizes an array of piezoelectric transducers attached to or embedded within the structure (composite structure, specifically) for both actuation and sensing functions. An experimental validation of the invented system was performed on composite flex beam with Active Control eXperts (ACX) QP20W QuickPack transducers bonded to the surface of the flex beam.

[0041] U.S. Pat. No. 6,370,964 describes a "diagnostic layer" containing a network of actuators and sensors. The layer may be incorporated into or placed on the surface of composite material for structural health monitoring, including detection of the site and extent of damage. The diagnostic layer can also be adapted to monitor the cure process of a composite. A diagnostic layer includes a thin and flexible dielectric substrate, a network of embedded piezoelectric devices (actuators and sensors, which are preferably not distinct), and a plurality of conductive elements which

are electrically interconnecting the actuating and sensing devices. The diagnostic layer can be embedded into fiber-reinforced composite during its fabrication.

[0042] U.S. Pat. No. 6,399,939 describes a nondestructive monitoring system, which includes a sensor array called "discrete sensor nodes", each of them generating an electrical signal in response to a damage, failure or other type structural anomaly. In the preferred embodiment, the sensor nodes are represented by a plurality of piezoceramic fibers arranged in a planar array, in which the fibers are aligned substantially parallel to each other. The piezoceramic fiber ribbon can be woven as a straight fiber into a fabric, which is, importantly, in the context of this invention, a two-dimensional fabric.

[0043] With the great progress in miniaturization of microprocessors, antennas, electric power suppliers, data acquisition and storage systems, as well as many other microelectronic systems, devices and networks, it becomes more and more feasible to embed/integrate entire sensing, actuation, and self-control systems into the body of an aircraft, spacecraft, or other transportation means. This obviously includes smart composite structures. Several examples of such embedment/integration, found in the prior art, are described in the conclusion of this overview.

[0044] U.S. Pat. No. 5,184,141 describes a structurally-embedded electronics assembly for integration with the load-bearing structure of an aircraft. The assembly includes both sensors and antennas, the latter ones may be printed circuit antennas. The antenna may be embedded between layers of the structural material. As suggested in this invention, one desirable objective is to control the permeability and permittivity of the materials surrounding the embedded antenna in order to maximize its performance. This can be relatively easily achieved with the use of composite materials by adding short carbon or glass fibers, metal particles or the like to the matrix material to change its electromagnetic properties.

[0045] U.S. Pat. No. 5,440,300 describes embedded smart structures that include active electronics which control and collect data from sensors and actuators and transmit data to the exterior of the structure by electromagnetic antenna radiation. Multiple embedded sensors, each having its individual antenna, are powered and interrogated by a single external powering and data interrogation antenna. According to this concept, the smart panel can be made of any material which is compatible with and suitable for embedding/integrating electronics. Specifically, the panel may contain in its interior volume a thin film package with sensors and radio frequency antenna extending therefrom.

[0046] U.S. Pat. No. 6,529,127 describes a multidrop network of multichannel, addressable sensing modules embedded within a composite structure, remotely powered, and interrogated by a personal computer via a non-contacting inductive link. These modules represent advanced, micro-miniature sensing network. The invention describes the combination of embedded microprocessors, highly integrated sensor signal conditioners, digital data converters, and the use of networking technics, especially for smart structure application. As suggested in the invention, by placing the aforementioned components on a flexible polyimide substrate, addressable sensing modules may be directly bonded to the surface of a composite structure's

main load-bearing components. Further, the material's final protective overcoat may be used to embed them within the composite structure. The modules can be adapted to the physical limitations dictated by each specific application.

[0047] It can be concluded from the above overview of the prior art methods of embedding/integrating of a broad spectrum of systems, devices and networks into composite materials, structures and textile fabrics, none of them had addressed the use of three-dimensional woven, braided, knitted, stitch bonded fabrics or preforms for composites, as the carriers of the said systems, devices and networks. Furthermore, no intent can be traced in the prior art of using textile processes and machinery for incorporating said systems, devices and networks into the processes of manufacturing such three-dimensional fabrics and preforms for composites. The present invention is intended to fill this gap in the prior art.

[0048] Generally, much of the relevant prior art may be categorized as being within a few broad areas, including fiber optic sensors, piezoelectric sensors/actuators/transducers, conducting fibers, electronics assemblies/networks, and fabric diagnostics. Select references from the prior art are identified and briefly described and distinguished from the present invention hereinbelow.

[0049] Thus, there remains a need for a 3-D fabric having systems, devices, and/or networks integrated therewith for providing a 3-D fabric or preform for use on its own and/or as a composite.

SUMMARY OF THE INVENTION

[0050] The present invention is directed to a 3-D fabric having systems, devices, and/or networks integrated therewith.

[0051] Preferably, the 3-D fabric is formed by 3-D weaving, knitting, braiding, or other 3-D fabric forming method, or combinations thereof, for providing an integral, unitary structure.

[0052] The present invention is further directed to a method for forming the 3-D fabric having systems, devices, and/or networks integrated therewith, where the systems, devices, and/or networks are introduced before, during or after the fabric-forming method for a fabric or preform and prior to the formation of a composite with the preform, where the fabric is intended to be used as or within a composite structure.

[0053] Thus, the present invention solves the problems of the prior art and/or introduces solutions not previously taught or suggested in the prior art.

[0054] Accordingly, one aspect of the present invention is to provide a 3-D fabric preform for composites including a three-dimensional engineered fiber preform formed by intersecting yarn system components; and at least one system, device, and/or network integrated with the preform for providing a predetermined function, wherein the at least one system, device, and/or network is introduced prior to formation of a composite structure including the preform, thereby providing a 3-D fabric preform for composites. Another aspect of the present invention is to provide a method for forming the 3-D fabric preform for composites including a three-dimensional engineered fiber preform

formed by intersecting yarn system components; and at least one system, device, and/or network integrated with the preform for providing a predetermined function, wherein the at least one system, device, and/or network is introduced prior to formation of a composite structure including the preform, thereby providing a 3-D fabric preform for composites.

[0055] These and other aspects of the present invention will become apparent to those skilled in the art after a reading of the following description of the preferred embodiment when considered with the drawings.

BRIEF DESCRIPTION OF THE DRAWINGS

[0056] FIG. 1 is a perspective view illustrating an embodiment according to the present invention.

[0057] FIG. 2 is a perspective view of another embodiment according to the present invention.

[0058] FIG. 3 is another perspective view of an embodiment according to the present invention.

[0059] FIG. 4 is a schematic of another embodiment according to the present invention.

[0060] FIG. 5 is a schematic of another embodiment according to the present invention.

[0061] FIG. 6 is a perspective view illustrating an embodiment according to the present invention.

[0062] FIG. 7 is a perspective view of another embodiment according to the present invention.

[0063] FIG. 8 is a perspective view of another embodiment according to the present invention.

[0064] FIG. 9 is a perspective view of another embodiment according to the present invention.

[0065] FIG. 10 is a perspective view of another embodiment according to the present invention.

[0066] FIG. 11 is a side or edge view of another embodiment according to the present invention.

[0067] FIG. 12 shows Flexible System/Device Materials Joining Base Material in Fabric Formation Process by Addition.

[0068] FIG. 13 shows Flexible System/Device Materials Joining Base Material in Fabric Formation Process by Substitution

[0069] FIG. 14 shows Rigid System/Device Materials Joining Base Material in Fabric Formation Process by Addition

[0070] FIG. 15 shows Rigid System/Device Materials Joining Base Material in Fabric Formation Process by Substitution

[0071] FIG. 16 shows Flexible System/Device Materials Joining Base Material after Initial Fabric Formation Process by Addition

[0072] FIG. 17 shows Rigid System/Device Materials Joining Base Material after Initial Fabric Formation Process by Addition

[0073] FIG. 18 shows Flexible System/Device Materials Joining Base Material after Initial Fabric Formation Process by Substitution

[0074] FIG. 19 shows Flexible System/Device Materials Joining Base Material after Initial Fabric Formation Process by Addition

[0075] FIG. 20 shows System/Device Materials Integrated during Preforming Emerge in Dangling Fashion from Composite According to Design

[0076] FIG. 21 shows System/Device Materials Integrated during Preforming Meet Surface of Composite for Access According to Design

[0077] FIG. 22 shows Example of 3-D Braided Fabric/Preform with Integrated System/Device Materials

[0078] FIG. 23 shows a 3-D Braided T-Stiffener Preform Showing Integration of System/Device Materials Along both Axial and Braiding Pathways.

[0079] FIG. 24 shows a 3-D Multi-Axial Woven Fabric/Preform with System/Device Materials Integrated into Warp, Fill and Bias Pathways

[0080] FIG. 25 shows a 3-D Multi-Axial Warp-Knitted or Stitch-Bonded Fabric/Preform with System/Device Materials Integrated into Warp, Fill and Bias Pathways

[0081] FIG. 26 shows an Illustration of Addition or Substitution of System/Device Materials into Fabric/Preform During Regular Fabric Formation

[0082] FIG. 27 shows an Illustration of Addition or Substitution of System/Device Materials into Fabric/Preform After Regular Fabric Formation

[0083] FIG. 28 is a digital photograph of Optical fiber included in fiber supply for additive integration into 3-D weaving.

[0084] FIG. 29 is a digital photograph of Laser light going into network material in standard supply "creel" and into loom.

[0085] FIG. 30 is a digital photograph of Rigid EFPI is miniature and was integrated automatically in 3-D weaving.

[0086] FIG. 31 is a digital photograph of Optical fiber emerging from 3-D woven preform.

[0087] FIG. 32 is a digital photograph of 32 Preform being processed into composite by VARTM method.

[0088] FIG. 33 is a digital photograph of Carbon fiber composite beam test specimens with rigid integrated sensors along straight paths.

[0089] FIG. 34 is a digital photograph of Fabric with integrated 11 optical fibers in 3 axes.

[0090] FIG. 35 is a digital photograph of Braided preform with integrated optical fibers in axial looped circuit (2 round trips).

[0091] FIG. 36 is a digital photograph of Composite produced with preform having optical sensing fiber pulled in additively after fabric formation; it contains hundreds of sensors.

[0092] FIG. 37 is a digital photograph of Heat from fingers touching sensing fiber.

[0093] FIG. 38 is a digital photograph of Fibers and signal emerge from completed fabric showing signal still coming from supply.

DETAILED DESCRIPTION OF THE PREFERRED EMBODIMENTS

[0094] In the following description, like reference characters designate like or corresponding parts throughout the several views. Also in the following description, it is to be understood that such terms as “forward,” “rearward,” “front,” “back,” “right,” “left,” “upwardly,” “downwardly,” and the like are words of convenience and are not to be construed as limiting terms.

[0095] Referring now to the drawings in general, the illustrations are for the purpose of describing a preferred embodiment of the invention and are not intended to limit the invention thereto. As best seen in FIG. 1, a 3-D fabric preform for composites is provided, generally referenced 10, for providing a three-dimensional engineered fiber preform formed by intersecting yarn system components 4, 6, and 8, respectively; and at least one system, device, and/or network from a supply 12, 14 integrated with the preform for providing a predetermined function, wherein the at least one system, device, and/or network is introduced prior to formation of a composite structure including the preform, as illustrated in this figure, thereby providing a 3-D fabric preform for composites. The supply may include a flexible network or device 12 and/or a rigid network or device 14.

[0096] In one preferred embodiment of the present invention, as shown in FIG. 1, a fabric preform being formed on a fabric forming machine includes, as part of the fabric forming process, the addition and integration of at least one system, device, and/or network along with the fiber systems used to form the fabric structure; this may be done automatically, semi-automatically, or manually, depending upon the specific system, device and/or network being used.

[0097] In another preferred embodiment of the present invention, as shown in FIG. 2, a fabric preform 18 that has already been formed on a fabric forming machine is now having the addition and integration of at least one system, device, and/or network 26, 20, 22, within the fiber systems used to form the fabric structure; this may be done automatically, semi-automatically, or manually, depending upon the specific system, device and/or network being used. FIG. 2 further illustrates the addition of a device/network material(s) by insertion, stitching, or as with “embroidery” 16, as well as the addition of rigid device/network materials by insertion, displacement, or pull-through along straight paths 20, and the addition of flexible device/network materials by insertion, displacement, or pull-through along straight paths 22.

[0098] FIG. 3 shows an example of a special shaped fabric or preform with integrated network, device, and/or sensors. In particular, flexible network/device/sensor materials are shown following a convoluted path 24 and rigid flexible network/device/sensor materials are shown following a straight path.

[0099] FIG. 4 illustrates by a schematic view the addition of network, device, and/or sensor materials to a textile system supply 28, which proceed through any textile processing system 30 according to the present invention as set

forth herein, to provide a textile fabric or preform 32 having integrated network, device, and/or sensor materials therewith as part of the integral, unitary construction of the 3-D fabric or preform.

[0100] FIG. 5 illustrates by a schematic view the addition or substitution 42 of network, device, and/or sensor materials 44 into a textile fabric or preform, wherein the fabric or preform are first formed from a textile system supply 34 having standard materials only in the supply, i.e., not including any network, device, and/or sensor materials, the standard supply proceeding through any textile processing system 36 according to the present invention as set forth herein, to provide a textile fabric or preform having integrated network, device, and/or sensor materials therewith as part of the integral, unitary construction of the 3-D fabric or preform 46.

[0101] The preform according to the present invention may be formed by various fabric-forming processes, resulting in 3-D woven fabric, 3-D braided fabric, and/or 3-D multiaxial fabric structures. Where a 3-D braided fabric is used, preferably the systems, devices, and/or networks are provided in the axial direction of the structure. In some specific systems, such as conductive components or sensors may be used in other directions within the structure. For a typical 3-D braided fabric formed on an automated machine, 64 carriers with holes or tubes for axial fibers are preferably used to integrate the systems, devices and/or networks via the tubes into the braided fabric in an automated manner. Semi-automated and manual introduction may be used as well or as an alternative. In the case of a 3-D multiaxial fabric, typically stitch-bonded or multi-axial warp-knitted fabrics (stitched through the thickness) or insertion fabrics (generally not composites applications) may be used.

[0102] FIG. 6 is a perspective illustration showing the addition of relatively smaller rigid system/device materials to certain elements within a Multi-Axial Warp Knit, Stitch Bonded, or other insertion fabric/preform such as that manufactured by the Liba, Mayer, or other similar 3-D fabric formation processes. The un-crimped in-plane pathways allow for the integration of both rigid and flexible system/device materials. Knitting/Stitching which alternate from top to bottom, binding the assembly, follow a more complex path, allow for the integration of only the most flexible system/device materials, while rigid system/device materials may merely be inserted between the base yarns in the through thickness direction as if a needle through fabric. As seen in FIG. 6, rigid or flexible system, device, network, and/or sensor materials 38 are added to the base materials; also, knitting or stitching yarns 40 are shown, along with in-plane 0°, 90°, +45°, -45° yarns 42 in the base fabric structure.

[0103] FIG. 7 is a perspective illustration showing the substitution of relatively equal sized rigid system/device materials for certain elements within a Multi-Axial Warp Knit, Stitch Bonded, or other insertion fabric/preform such as that manufactured by the Liba, Mayer, or other similar 3-D fabric formation processes. The un-crimped in-plane pathways allow for the integration of both rigid and flexible system/device materials. Knitting/Stitching which alternate from top to bottom, binding the assembly, follow a more complex path, allow for the integration of only the most flexible system/device materials while rigid system/device

materials may merely be inserted between the base yarns in the through thickness direction as if a needle through fabric. As seen in **FIG. 7**, rigid or flexible system, device, network, and/or sensor materials **46** are being substituted for the base materials; also, knitting or stitching yarns **44** are shown, along with in-plane 0° , 90° , $+45^\circ$, -45° yarns **48** in the base fabric structure.

[0104] **FIG. 8** is a perspective illustration showing the addition of relatively smaller system/device materials to certain elements within a Multi-Axial 3-D woven fabric/perform. The un-crimped in-plane pathways allow for the integration of both rigid and flexible system/device materials. Z-yarns, which alternate from top to bottom of 3-D Multi-Axial weave, connecting the assembly, follow a more complex path, which allows only for the integration of continuous flexible system/device materials or discrete rigid system/device materials. As seen in **FIG. 8**, rigid or flexible system, device, network, and/or sensor materials **50** are being added to the base materials; also, z-yarns **52** are shown, along with in-plane 0° , 90° , $+45^\circ$, -45° yarns **54** in the base fabric structure.

[0105] **FIG. 9** is a perspective illustration showing the substitution of relatively equal sized rigid system/device materials for certain elements within a Multi-Axial 3-D woven fabric/perform. The un-crimped in-plane pathways allow for the integration of both rigid and flexible system/device materials. Z-yarns, which alternate from top to bottom of 3-D Multi-Axial weave, connecting the assembly, follow a more complex path, which allows for the integration of continuous flexible system/device materials or discrete rigid system/device materials. **FIG. 9** shows isolated system, device, network, and/or sensor materials **56** in the filling or bias direction, isolating base materials **58**, and common system/device materials **60** forming a simple circuit from the isolated system, device, network, and/or sensor materials in the filling or bias direction.

[0106] **FIG. 10** is perspective illustration of how the system/device materials in Filling or Bias directions are included in simple circuit formed by planned intersections with system/device materials in special Z-yarn. This is exemplary of how the sequence of interlacement of various elements within the fabric may be controlled or manipulated in three dimensions so as to allow periodic access to a system/device, or to form planned intersections with in-plane elements and thus circuits as desired. As seen in **FIG. 10**, rigid or flexible system, device, network, and/or sensor materials **62** are being substituted for the base materials; also, z-yarns **64** are shown, along with in-plane 0° , 90° , $+45^\circ$, -45° yarns **66** in the base fabric structure.

[0107] **FIG. 11** is an edgewise illustration of how the system/device materials in Filling or Bias direction are included in simple circuit formed by planned intersections with system/device materials in special Z yarn and the sequence of interlacement may be controlled or manipulated so as to allow periodic access to a system/device, or to form planned intersections with in-plane elements and thus circuits as desired. **FIG. 11** shows Z/Axial **74** having an altered path making intended intersection with other system/device materials, a circuit path A-A **76**, along with in-plane 0° , 90° , $+45^\circ$, -45° yarns **72**, **70**, **68**, respectively, in the base fabric structure.

[0108] **FIG. 12** shows Flexible System/Device Materials Joining Base Material in Fabric Formation Process by Addition.

[0109] **FIG. 13** shows Flexible System/Device Materials Joining Base Material in Fabric Formation Process by Substitution.

[0110] **FIG. 14** shows Rigid System/Device Materials Joining Base Material in Fabric Formation Process by Addition

[0111] **FIG. 15** shows Rigid System/Device Materials Joining Base Material in Fabric Formation Process by Substitution

[0112] **FIG. 16** shows Flexible System/Device Materials Joining Base Material after Initial Fabric Formation Process by Addition

[0113] **FIG. 17** shows Rigid System/Device Materials Joining Base Material after Initial Fabric Formation Process by Addition

[0114] **FIG. 18** shows Flexible System/Device Materials Joining Base Material after Initial Fabric Formation Process by Substitution

[0115] **FIG. 19** shows Flexible System/Device Materials Joining Base Material after Initial Fabric Formation Process by Addition

[0116] **FIG. 20** shows System/Device Materials Integrated during Preforming Emerge in Dangling Fashion from Composite According to Design

[0117] **FIG. 21** shows System/Device Materials Integrated during Preforming Meet Surface of Composite for Access According to Design

[0118] **FIG. 22** shows Example of 3-D Braided Fabric/Preform with Integrated System/Device Materials

[0119] **FIG. 23** shows a 3-D Braided T-Stiffener Preform Showing Integration of System/Device Materials Along both Axial and Braiding Pathways.

[0120] **FIG. 24** shows a 3-D Multi-Axial Woven Fabric/Preform with System/Device Materials Integrated into Warp, Fill and Bias Pathways

[0121] **FIG. 25** shows a 3-D Multi-Axial Warp-Knitted or Stitch-Bonded Fabric/Preform with System/Device Materials Integrated into Warp, Fill and Bias Pathways

[0122] **FIG. 26** shows an Illustration of Addition or Substitution of System/Device Materials into Fabric/Preform During Regular Fabric Formation

[0123] **FIG. 27** shows an Illustration of Addition or Substitution of System/Device Materials into Fabric/Preform After Regular Fabric Formation

[0124] **FIG. 28** is a digital photograph of Optical fiber included in fiber supply for additive integration into 3-D weaving.

[0125] **FIG. 29** is a digital photograph of Laser light going into network material in standard supply "creel" and into loom.

[0126] **FIG. 30** is a digital photograph of Rigid EFPI is miniature and was integrated automatically in 3-D weaving.

[0127] FIG. 31 is a digital photograph of Optical fiber emerging from 3-D woven preform.

[0128] FIG. 32 is a digital photograph of 32 Preform being processed into composite by VARTM method.

[0129] FIG. 33 is a digital photograph of Carbon fiber composite beam test specimens with rigid integrated sensors along straight paths.

[0130] FIG. 34 is a digital photograph of Fabric with integrated 11 optical fibers in 3 axes.

[0131] FIG. 35 is a digital photograph of Braided preform with integrated optical fibers in axial looped circuit (2 round trips).

[0132] FIG. 36 is a digital photograph of Composite produced with preform having optical sensing fiber pulled in additively after fabric formation; it contains hundreds of sensors.

[0133] FIG. 37 is a digital photograph of Heat from fingers touching sensing fiber.

[0134] FIG. 38 is a digital photograph of Fibers and signal emerge from completed fabric showing signal still coming from supply.

[0135] Manufacturing methods for, and resultant fiber/tow paths within various 3-D fabrics or preforms may be manipulated and exploited so as to allow a relatively easy integration of special, actively or passively functional, flexural or rigid materials within them, by adding said materials to one or more of the host fibers/tows or, alternatively, by replacing one or more fibers/tows with the said material. In this way, a fabric is created, which includes various systems, devices, networks, etc. Such 3-D fabrics and preforms containing integrated systems/devices/networks are the principal object of this invention.

[0136] Some immediate examples are 3-D fabrics and preforms with integrated optical fibers/fiber bundles and sensors integrated within them, which is one particular object of this invention; actuation means such as piezoelectric fibers, fiber bundles, ribbons, and other suitable elongated bodies for shape control, vibration and dynamic instability suppression, which is another particular object of this invention; electrical conductors like metal wires, filaments, strands made of stainless steel, copper, carbon, or electrically conductive polymers, which is another particular object of this invention. Besides, fast progress in the area of microelectronics and nanomaterials makes it feasible to associate complex microelectronic devices, systems and networks to textile fibers/tows and then integrate them into 3-D fabrics and preforms, which is yet another particular object of this invention.

[0137] Making use of complex fiber architecture in 3-D weaves, braids or knits provides endless opportunities for creating large arrays or networks of sensors, actuators, circuits, conduits and other systems and devices that may serve such purposes as transmitting light, providing controllable light displays for signals or screens or camouflage, conducting electricity and heat, performing logical functions, providing data and power infrastructure in structures, serving as antennae or emitters for sound or electrical power radiation, shielding electromagnetic waves, diffusing radiation or signals, inducing movement or shape change, de-icing, just to mention a few.

[0138] The system/device materials of interest may be integrated into 3-D fabric/preform during its formation on the respective machine or mechanism during the regular textile process, which is another object of this invention. Alternatively, they can be integrated after the fabric/preform has been produced, which is yet another object of this invention. Flexible system/device materials may be introduced along any pathway followed by the regular fiber/tow forming the fabric, specifically, in three, four or five directions, which are most typical cases for the 3-D fabrics of our primary interest. It is very important to ensure that going along such pathways does not impart severe damage to the system/device material, or does not substantially hurt the functional ability of that system/device. The ability and freedom of the 3-D preforms to provide straight pathways suitable for many device materials, while at the same time providing efficient structural performance is an advantage of the present invention over the inclusion of similar device materials in 2D fabrics which are limited in this respect.

[0139] Integration may take place in several fashions, including simply substituting the system/device material for the fiber/tow host material in desired locations during fabric formation, addition of the system/device material to the host materials during formation, replacement/substitution of the host materials after formation, and addition of the system/device materials to the host materials after formation. The described methods of integrating relatively flexible systems/devices into 3-D fabrics and preforms is another object of this invention. Straight (or nearly straight) pathways used in 3-D textile manufacturing processes (the immediate examples are warp fiber direction in 3-D orthogonal weaving, multiaxial 3-D weaving or multi-axial knitting/stitch bonding, and longitudinal fiber direction in 3-D braiding) allow even relatively rigid materials to be used, along with the regular fibers/tows without distortion or functional impingement to the integrated system/device material. This statement has been thoroughly verified through experimentation with both rigid and flexible optical devices and fibers, ceramic fiber, and stainless steel wire bundles on the available automated 3-D weaving and 3-D braiding machines. The described methods of integrating relatively rigid systems/devices into 3-D fabrics and preforms is another object of this invention.

[0140] Prior to formation of the fabric with integrated system/device material such as optical fiber, or metallic conductor, or piezoelectric/magneto-strictive actuator/sensor, or shape memory alloy element, may be wound together with the host fiber/tow in the desired ratio onto the standard spools or beams, thus forming a hybrid tow, which is loaded into the 3-D weaving, braiding or knitting machine so as to be included in the fabric formation process. Alternatively, the system/device material may be used as substitute for some number of regular fibers/tows by adding it to the supply of a textile machine as if weaving a simple plaid, ribbed, or hybrid fabric. Where the effects of the additional volume, mass, or other physical property of the system/device material causes no undesirable effects, the system/device material may be simply added to the existing host materials by methods including but not limited to fastening the system/device material to a host material and allowing it to be pulled into the already formed fabric as a parasite, or by allowing the system/device material to be inserted by the rapiers, needles, or fluid jets along with the resident host material. Standard "color picker"s and jacquard heddle

controls used for plaids and upholstery fabrics allow for on-demand placement of system/device material in looms, and the grippers on standard rapiers can accommodate rigid materials. The described methods of incorporating a system/device material into the tow/yarn supply system is another particular object of this invention.

[0141] The fundamental concept of integrating various systems/devices into 3-D fabrics and fabric preforms described above enables the next step, namely to manufacture polymer matrix, ceramic matrix, metal matrix, carbon-carbon or carbon-silicon composite materials and structures instrumented with such systems/devices. This concept, which is the second principal object of this invention, extends to any composite material, which can be made with the use of the aforementioned instrumented fabric preforms. Any suitable fabrication technique can be utilized for this purpose. In the case of polymer matrix composites one can use methods like Resin Transfer Molding, Vacuum Assisted Resin Transfer Molding, Resin Film Infusion, Pultrusion, Hot Press Forming, Autoclave Curing, etc. Of course, special care has to be taken to protect the integrated system/device against elevated cure temperatures/pressures or against elevated temperatures/pressures required for thermal forming of a composite structural part. The integrated system/device should not contain any structural elements, adhesives, coatings or other (typically polymeric) components that would not withstand the projected composite processing and/or in-service temperatures/pressures.

[0142] The above requirement becomes much more severe in the case of ceramic matrix, metal matrix and carbon-carbon composites, which must be processed at high temperatures, and likely exposed to high temperatures in service. The selection of appropriate systems/devices that can be safely integrated into these types of composites without special thermal protection means asks for special attention and care. For example, even if pure glass fibers and pure ceramic fibers can withstand high temperatures used for processing some of the aforementioned composites, conventional fiber optic sensors or piezoceramic actuators based, respectively, on glass or ceramic materials, may include various polymeric elements (claddings, substrate films, insulating casings, etc.), which will not withstand the high processing or in-service temperatures. To substantiate this point, we make a reference to U.S. Pat. No. 5,338,928, where it was suggested that “an optical fiber capable of high temperature environments can be inserted into the structure prior to chemical vapor infiltration as in the case of CMCs or prior to plasma spraying, foil-fiber-foil construction, or other assembly methods as in the case of MMCs”. However, according to that patent, each optical fiber was clad with an inert cladding, such as gold or iridium. Also, gold-coated silica fibers or sapphire fibers were suggested as the preferred types of fibers for integration into high-temperature composites.

[0143] Piezoelectric sensors/actuators commonly used for embedment into graphite fiber composite laminates require a suitable insulating casing, which can be, for example, a polyimide film Kapton, as suggested in U.S. Pat. No. 5,195,046 or a fiberglass fabric/epoxy composite, as recommended in U.S. Pat. No. 5,305,507. Of course, other suitable approaches can be explored. One possible solution, which is another object of this invention, is inspired by the nature of 3-D fabrics. Its essence is to functionally hybridize the

fabric, i.e., substitute glass fiber or other insulating material fiber tows for some of graphite fiber tows in those parts of the fabric where piezoelectric sensors/actuators have to be integrated. This approach enables to naturally surround the piezoelectric element with sufficient amount of insulating material fibers and thus ensure its insulation from graphite fibers contained in the other neighboring tows.

[0144] Electrical conductors, like metallic wires/fibers/strands or polymeric conducting fibers/yarns, represent another category of systems/devices that can be integrated into 3-D fabrics, preforms and composites, though they require special treatment before being used in the integration process. Depending on the functional purpose, different pre-integration treatments of this kind systems/devices can be applied. They may be intentionally left bare and allowed for mutual contacts at the crossover points, thus providing a conductive circuit. They may be left bare, but in a non-interlacing pattern (as dictated, for example, by the application considered in U.S. Pat. No. 5,210,499). They can be locally insulated by polymeric fibers/tapes or may be separated at the crossover points by special electrically partially resistive material (like in the case of the pressure sensor construction in U.S. Pat. No. 4,795,998). Some of these requirements can be naturally fulfilled by using another object of this invention, which is to purposefully choose those layers of warp, weft, and/or bias fibers/tows and specific locations within the 3-D fabric, where the electrically conductive system/device should be integrated. Yet, according to another object of this invention, an electrically conductive system/device, depending on its intended functional designation, can be either left bare without a host tow (e.g. by using the substitution approach) or being encapsulated within the necessary amount of insulating fibers of its host tow (e.g. by using the addition approach). With no doubt, the capability of using 3-D fabrics as the carriers of various conducting systems/devices/networks far exceeds the capability of 2-D fabrics and will inspire new efficient solutions.

[0145] Other technicalities of the invention in the parts of manufacturing 3-D fabrics, preforms and composites, will be clear to those skilled in the art, after getting familiar with the illustrations, their detailed description, and several reduction to practice examples.

[0146] The systems, devices, and/or networks integrated with the preform of the present invention are generally not required to provide any structural function within the preform, although they may optionally do so in particular embodiments.

[0147] In one embodiment of the present invention, optical fibers are integrated within the fabric preform of the present invention prior to composite formation, where the preform is intended for later use as a composite material or component.

[0148] Both optical capabilities and structural characteristics may be enhanced by using ribbons or bundles of fibers in place of single, discrete fibers integrated with the fabric preform of the present invention. Ribbons may comprise parallel strands for scanning devices, or interlaced strands to add structural integrity to the composite. Alternatively, interwoven bundles may be employed for structural purposes or to provide large cross section optical paths for illumination energy to be conducted from remote light sources to areas where illumination is desired for enhancing vision.

[0149] The present invention further includes a method for forming a 3-D preform for composites including the steps of: providing yarn system component for forming a three-dimensional engineered fiber preform formed by intersecting textile system components; and providing at least one system, device, and/or network integrated with the preform for providing a predetermined function, wherein the at least one system, device, and/or network is introduced prior to formation of a composite structure including the preform, thereby providing a 3-D fabric preform for composites. Additional steps may include introducing device/network materials to the textile system supply for integration with the preform in at least one fiber or pathway of the network materials; and producing the preform via a textile processing system; thereby producing a 3-D fabric having integrated networks/devices therein. Furthermore, the at least one fiber or pathway of the network materials, device and/or sensors may either be a substantially straight pathway, as in the case of optical fibers, especially glass fibers, or the at least one fiber or pathway may be flexible, as in the case of a flexible material/fiber where a non-straight pathway, e.g., an electrical circuit or network produced by integration of a plurality of convoluted pathways having predetermined intersection or contact points. Importantly, the method of the present invention provides for the introduction of the systems, devices, and/or networks and integration thereof with the preform prior to any composite formation steps, which obviously are intended to occur after the integration of the components with the preform according to the present invention where the preform is intended for use as a composite material.

[0150] Other method steps may be included or substituted without departing from the scope of the present invention, depending upon the particular systems, devices, and/or networks and combinations thereof that are integrated with the 3-D fiber preform and the application for the composite material that may ultimately be formed therewith.

[0151] The systems, devices, and/or networks integrated with the preform of the present invention are generally not required to provide any structural function within the preform, although they may optionally do so in particular embodiments.

[0152] In one embodiment of the present invention, optical fibers are integrated within the fabric preform of the present invention prior to composite formation, where the preform is intended for later use as a composite material or component.

[0153] Both optical capabilities and structural characteristics may be enhanced by using ribbons or bundles of fibers in place of single, discrete fibers integrated with the fabric preform of the present invention. Ribbons may comprise parallel strands for scanning devices, or interlaced strands to add structural integrity to the composite. Alternatively, interwoven bundles may be employed for structural purposes or to provide large cross section optical paths for illumination energy to be conducted from remote light sources to areas where illumination is desired for enhancing vision.

[0154] Regarding conductive materials, a conductor may comprise single- or multi-stranded wires, and suitable materials include stainless steel, tinned copper or carbon fiber.

[0155] Regarding applications wherein a structural component has piezoelectric fiber composite the structural layers

are made, for example, of standard carbon fiber reinforced composite material. Preferred embodiments include epoxy polymers, which are chemically and mechanically compatible with the polymers in the host composite structures, i.e., the piezoelectric composite epoxy is bondable to the structural composite epoxy and has similar mechanical and electrical properties. Preferably, the conductive layers are in direct contact with the fibers. The conductive electrode layers are relatively flexible. Thin metal layers are desirable, because they do not restrain the composite of the structural component during actuation. Silver is preferred. Other metals, which may be used, include aluminum, copper, and gold, as well as non-metallic conductors such as conductive polymers. In embodiments, the electrode layers may be formed of a thin polymer substrate coated with an ultra-thin layer of metal. The electrodes may be etched in a pattern. The electrode layers may adhere directly to structural materials.

[0156] The composites may be used in many structural components. For example, in aeroelastic structures for active control of composite wings to suppress flutter at high airspeeds by applying AC fields, thereby effectively increasing the top speed of an aircraft. The composites can be used for both sensing and actuation in a closed-loop configuration. The anisotropic nature of piezoelectric displacement can be maximized by choosing a polymeric material and piezoelectric ceramic material, which have large differences in their mechanical stiffnesses.

[0157] In the embodiment where a health monitoring system is used with the present invention, it may be based on the use of vibration signature of the structure to determine its mechanical and thermal state. Sensor modules are located throughout the structure and are connected to the host CPU by the high speed databus, by way of example and not limitation. A principle underlying the operation of a Health Monitoring System (HMS) of the present invention is the use of specimen vibration signatures to determine mechanical and thermal properties. A specimen vibration signature is derived from the dynamic response or reaction of the structure to a stimulus. Such dynamic response typically is the varying electrical output of transducers attached to the structure. The HMS applies this concept to obtain dynamic response characteristics corresponding to failure or damage of structural components. Specifically, HMS mechanically excites the structure and monitors its dynamic response through sensors or feedback transducers. The excitation energy is preferably in the form of a single pulse, which generates a wideband frequency range of vibration of the structure. The feedback transducers are preferably piezoelectric film transducers. Pattern recognition techniques are used to process vibration signals and classify the type and location of structural damage. In addition to the pattern recognition techniques, key components of the overall HMS include intelligent sensor modules, a host central processing unit (CPU), and a high speed databus. The sensor module contains an actuation mechanism to generate a physical impulse and apply it to the structure, and feedback transducers and signal processing circuitry to detect the corresponding vibration signals, process them, and transmit the preferably digitized data to the host CPU when queried. The sensor module is also provided with an embedded processor for controlling the actuation mechanism as well as for data acquisition. The host CPU executes pattern recognition

software which distinguishes among fatigue cracks, rivet line failure, ice or material buildup on the structure, and other disturbances.

DESIGN EXAMPLE(S)

[0158] This section outlines a few design examples, not necessarily optimized or intended to limit the scope of the invention thereto, but illustrative of what can be done for a fabric preform having integrated systems, devices, and/or networks according to the present invention, wherein the systems, devices, and/or networks are integrated with the preform prior to composite formation, where the fabric is intended for later composite applications. These design examples include, but are not limited to, the following:

[0159] In the practical implementation of the present invention, various embodiments may be constructed using a range and combination of many types of system or device materials according to the desired function of the complete system or device within the fabric or composite structure/part made with it. Combinations of passive, active, conductive, fluidic conduit, optical conduit and many more may be employed so to achieve the desired functions. Among the most commonly desired features of diagnostics and health monitoring of a structure or part is to determine, measure, or monitor the strain, stress, damage, delamination, cracks, temperature, moisture, acceleration, and other performance characteristics, which are usually hidden in the interior of the materials or in parts of the structure which are difficult to access for inspection, as was described in section "BACKGROUND OF THE INVENTION". This is one of many applications referred to as smart materials or smart structures. Current application of optical sensors in aircraft and spacecraft requires bonding optical sensors to the surfaces, or embedding them between plies of a laminated composite. This leaves delicate fibers exposed, the fibers may move during infusion or curing, and may induce delamination along the delicate bond line between the laminate plies.

[0160] Several prototypes of embodiment of the present invention have been demonstrated toward this particular purpose. It should be noted that the prototypical demonstrations are not exhaustive but rather exemplary of modifications to composite construction methods and might be considered a sub-element of a larger composite structure or vehicle such as a fuselage section, hull skin, wing panel, composite beam or strut within a boat or aircraft, windmill blade, or rotor shaft among others.

[0161] Continuous supply of warp (axial) optical fiber from creels or beams has proven to be quite suitable in automation. Likewise, continuous optical fibers were placed uncut repeatedly, back and forth, across the width of the preform in the weft direction at several levels forming a regular grid. The transmitted light intensity was measured during weaving and efficiencies found to be suitable. Experimental data collected from tested specimens allowed mapping strains and clearly indicated internal strain gradients near stress risers and loading sites.

[0162] Manufacture of said smart structure prototypes included the accomplishment of several step-wise tasks. Automated production of preforms for composite materials instrumented with fiber optic sensors has been performed. Optical fibers and sensors have been integrated into 3-D

woven and 3-D braided preforms by addition, and substitution, both before and after initial preform fabric formation. Continuous automated integration of optical fibers into 3-D weaving process during fabric formation was performed, sensors of both rigid and flexible types were integrated into 3-D fabrics, several methods were utilized to mark and map optical fiber and sensor positions within composites, demonstration of various methods of connection to the optical systems have been applied and refined, and testing of composite coupons instrumented with large number of integrated sensors has yielded useful data quantifying the internal strain state of the material.

[0163] In one particular demonstration, eleven spools were wound with one optical fiber each having acrylic coating, the bound end of each was connected to by fusion slicing, whereupon those same spools were mounted in a creel, and in filling stands, along with hundreds of other spools having variously carbon, glass, or Kevlar tows arranged to supply the weft, warp, and z yarns to a loom for producing a multi-layer 3-D woven hybrid fabric. The free end of each optical fiber was passed through standard, or modified guides so as to merge with selected base fabric structural fibers in the warp, weft, and z directions within the fabric. Those optical fibers added to the weft supply merged with the weft yarns near the tips of the rapiers used by the machine during insertion of weft yarns during the process of weaving and passed through the final rapier eyelets as an integral part of the weft yarn at that point during weaving. The z yarns were passed through particularly chosen heddles and followed those harness motions during weaving. A laser detector was connected to the optical fibers near the fell of the fabric at the loom after the optical fibers were teased from their parent and carrier structural fibers. Laser light was injected into the optical fibers at the supply spool, and the intensity of the light transmitted was documented during weaving as all effects of the weaving system and the effects of integration in the fabric accumulated. Light transmission was found to be suitable, efficient, and particularly so in the straight, in-plane weft-directional optical fibers. Results of weaving trials showed that transmission efficiencies are nearly unaffected by the fiber path in the warp and weft directions within the fabric. Losses do occur at tight bends in the z-directional fibers at the bends seen at the top and bottom surfaces, though those losses may be mitigated by manipulation of the z yarn paths and choice of fiber and signal types.

[0164] In another demonstration, one E-glass 3-D braided preform was produced containing 4 optical fibers incorporated in axial tows. Transmission efficiency was measured after braiding. Not surprisingly, the losses in the practically straight axial fibers were very low.

[0165] In another demonstration, at least 9 EFPI fiber optic sensors with 830 nm optical fiber leads were integrated into an 8-weft and 7-warp layer 3-D woven carbon fiber preform during weaving on a digitally controlled automated 3-D weaving machine. The rigid sensors and their flexible leads were carried into the fabric along with the regular carbon fiber material in the weft direction periodically, and in several of the 8 weft layers within the 0.8 inch thick multi-layer fabric. The preform was cut in the weft direction down to nominally 12"×18". Each of the fibers having one EFPI sensor along their length passed across the preform intimately with one carbon weft yarn yielding a preform

with 9 EFPI sensors at several depths through the fabric. Additionally, during momentary pauses of the loom, several EFPI sensors were placed through the thickness of the fabric by lowering them through the z corridor at the fell until stopped by a tape flag adhered at a known location leaving the EFPI suspended at a known depth in the fabric when the loom was released, and the fabric continued to form. Also, certain of the sensor/fiber assemblies had FC type connectors applied prior to weaving and as such, those connectors were integrated into the fabric and were located at the selvedge of the same. The ends of the sensing fibers were left long, extending as if fringe beyond the edges of the fabric, and the z axis sensor leads were bent 90 degrees at the surface and integrated into the topmost weft yarn until they reached the edge of the fabric.

[0166] The 3-D carbon fiber preforms were placed under a simple vacuum bag on a flat surface with an olefin platen on top, and with vacuum grease packed into the connectors to exclude resin from them, while the free ends of the optical fibers were sleeved with a small fluoro-polymer tubes, and passed across and shallowly embedded in the mastic vacuum seal. The preform was infused with an epoxy modified vinyl-ester resin, cured at room temperature, removed from the bag, and post-cured for several hours at 250 F per the resin manufacturers recommendations. Three instrumented test coupons were cut from different sections of the same panel. Connections to those fiber ends left free were made by cleaving, and fusion splicing of FC connectorized 1550 nm SMF leads, using a Fujikura semi-automated splicer. Connection to those fibers with the connectors woven in were made by rinsing out the grease, and mating with the corresponding male FC connector to the interrogation system. Finally, resistive foil strain gauges were adhered to the surfaces as references, and the internally instrumented composite specimen was mechanically tested in 4-point bending. The optical sensors were interrogated during loading by commercially available demodulation systems. Strains at several points within the composite beams were displayed in real time during loading, and clearly reflected internal strain gradients within the composite material near stress risers and loading sites.

[0167] In another demonstration, at least 16 EFPI fiber optic sensors with 830 nm optical fiber leads were integrated into a 7 weftx6 warp layer 3-D woven carbon fiber preform during weaving on a digitally controlled automated 3-D weaving machine. The rigid sensors and their flexible leads were carried into the fabric along with the regular carbon fiber material in the weft direction periodically, and in several of the 7 weft layers within the 0.5 inch thick multi-layer fabric. The preform was cut in the weft direction. Each of the fibers had one EFPI sensor along their length passed across the preform intimately with one carbon weft yarn yielding a preform with 9 EFPI sensors at several depths through the thickness. Additionally, during momentary pauses of the loom, several EFPI sensors were placed through the thickness of the fabric by inserting them through the z corridor at the fell until stopped by a tape flag adhered at a known location, leaving the EFPI suspended at a known depth in the fabric when the loom was released, and the fabric continued to form. Also, certain of the sensor/fiber assemblies had FC type connectors applied prior to weaving, and as such, those connectors were integrated into the fabric and were located at the selvedge of the same. The ends of the sensing fibers were left long, extending as if fringe beyond

the edges of the fabric, and the z axis sensor leads were bent 90 degrees at the surface and integrated into the topmost weft yarn until they reached the edge of the fabric.

[0168] The 3-D carbon fiber preforms were placed under a simple vacuum bag on a flat surface with an olefin platen on top, while the free ends of the optical fibers were sleeved with a small fluoro-polymer tubes, and passed across and shallowly embedded in the mastic vacuum seal. The preform was infused with an epoxy modified vinyl-ester resin, cured at room temperature, removed from the bag, and post-cured for several hours at 250 F per the resin manufacturers recommendations. Three instrumented test coupons with special notch-like features were milled from the same panel using carbide cutters. Connections to those fiber ends left free were made by cleaving, and fusion splicing of FC connectorized leads, using a semi-automated splicer. Finally, resistive foil strain gauges were adhered to the surfaces as references, and the internally instrumented composite specimen was mechanically tested in tension. The EFPI sensors were interrogated during loading by commercially available demodulation systems. Strains in the test direction and through thickness at several points within the composite beams were monitored using the sensors in real time during loading, and clearly indicated internal strain gradients near the notches.

[0169] In another demonstration, at least ten flexible DSS brand optical fibers manufactured by Luna Innovations were integrated into a previously formed 3-D woven carbon fiber preform in the weft direction by attaching the optical fibers to duplicates of the selected host yarns, fastening the joined pair to the selected host yarn and pulling out the host, thereby replacing the regular yarn with the instrumented yarn. This was performed periodically, and in five of the nine layers within the 0.235 inch thick multi-layer fabric, which had been cut to nominally 12"x18". Each of the optical fibers having multiple Bragg gratings each 5 mm long and paced every 10 mm along the fiber length passed across the preform intimately with one carbon weft yarn, returned with another and so on, yielding a preform with more than 360 Bragg grating sensors within the confines of the preform. The ends of the sensing fibers were left long, extending as if fringe beyond the edges of the fabric. The 3-D carbon fiber preforms were then placed under a simple vacuum bag on a flat surface while the free ends of the optical fibers were sleeved with a small fluoro-polymer tubes, and passed across and shallowly embedded in the mastic vacuum seal. The preform was infused with an epoxy modified vinyl-ester resin, cured at room temperature, removed from the bag, and post-cured for several hours at 250 F per the resin manufacturers recommendations. Connections were made by cleaving, and fusion splicing of FC connectorized 1550 nm SMF leads, using a Fujikura semi-automated splicer. Notches were machined into certain specimens after elastic testing with 1/2 hole at each edge, thus inducing a strain gradient. Finally, resistive foil strain gauges were adhered to the surfaces as references, and the internally instrumented composite specimens were mechanically tested in 4-point bending. The Bragg gratings were interrogated during loading by commercially available demodulation equipment produced by Luna Innovations. Strains at hundreds of points were displayed in real time during loading, and clearly indicated internal strain gradients near stress risers and loading sites.

[0170] In another demonstration, at least eighteen flexible DSS brand optical fibers manufactured by Luna Innovations were integrated into a previously formed 3-D woven carbon fiber preform in the weft direction periodically, and in five of the nine layers within the 0.235 inch thick multi-layer fabric which had been cut to nominally 12"×24". Each of the optical fibers having multiple Bragg gratings each 5 mm long and spaced every 10 mm along their length passed across the preform intimately with one carbon weft yarn, returned with another and so on, yielding a preform with more than 550 Bragg grating sensors within the confines of the fabric. The ends of the sensing fibers were left long, extending as if fringe beyond the edges of the fabric. The 3-D carbon fiber preforms were placed under a simple vacuum bag on a flat surface, while the free ends of the optical fibers were sleeved with a small fluoro-polymer tubes, and passed across and shallowly embedded in the mastic vacuum seal. The preform was infused with an epoxy modified vinyl-ester resin, cured at room temperature, removed from the bag, and post-cured for several hours at 250 F per the resin manufacturers recommendations. Two sensor instrumented, and two sensor-free coupons were cut from different sections of the same panel and bonded to form a double-lap joint specimen using epoxy adhesive. Connections were made by cleaving, and fusion splicing of FC connecterized 1550 nm SMF leads, using a Fujikura semi-automated splicer. Next, resistive foil strain gauges were adhered to the surfaces as references, and the internally instrumented double-lap composite bonded joint specimen was mechanically tested in tension. The Bragg gratings were interrogated during loading by commercially available demodulation equipment produced by Luna Innovations. Strains at hundreds of points were displayed in real time during loading.

[0171] Certain modifications and improvements will occur to those skilled in the art upon a reading of the foregoing description. All modifications and improvements have been deleted herein for the sake of conciseness and readability but are properly within the scope of the following claims.

What is claimed is:

1. A 3-D fabric or preform for composites comprising:
 - a three-dimensional engineered fiber preform formed by intersecting yarn system components; and
 - at least one system, device, and/or network integrated with the preform for providing a predetermined function,
 wherein the at least one system, device, and/or network is introduced prior to formation of a composite structure including the preform,
 - thereby providing a 3-D fabric preform for composites.
2. The preform according to claim 1, wherein the at least one system, device, and/or network is introduced at or during the fabric-forming process.
3. The preform according to claim 1, wherein the at least one system, device, and/or network is introduced after the fabric-forming process, but prior to the formation of the composite or other application of the fabric.
4. The preform according to claim 2, wherein the at least one system, device, and/or network is integrated with the preform while the preform is being formed on a machine.

5. The preform according to 1, wherein the at least one system, device, and/or network is automatically integrated with the preform.

6. The preform according to claim 1, wherein the at least one system, device, and/or network is manually integrated with the preform.

7. The preform according to claim 1, wherein the preform is formed from a 3-D woven fabric.

8. The preform according to claim 1, wherein the preform is formed from a 3-D orthogonally woven fabric.

9. The preform according to claim 1, wherein the preform is formed from a 3-D braided fabric.

10. The preform according to claim 1, wherein the preform is formed from a 3-D multiaxial fabric.

11. The preform according to claim 1, wherein the at least one system, device, and/or network includes at least one sensor.

12. The preform according to claim 11, wherein the at least one sensor is selected from the group consisting of fiber optic sensors, piezoelectric sensors, temperature sensors, pressure sensors, piezomagnetic sensors, electrically conductive sensors, hydraulic sensors, and combinations thereof, and combinations thereof.

13. The preform according to claim 1, wherein the at least one system, device, and/or network includes electrically conductive components.

14. The preform according to claim 1, wherein the components include electrically conductive components aimed at telecommunication, data transmission, electromagnetic reception, electromagnetic transmission, electromagnetic diffusion/diffraction, electromagnetic shielding of electronic equipment, personnel protection against electromagnetic radiation, and other similar functions which are distinct from the functions of sensing and actuation.

15. The preform according to claim 1, wherein the at least one system, device, and/or network includes at least one actuator.

16. The preform according to claim 1, wherein the at least one system, device, and/or network includes at least one transducer.

17. The preform according to claim 1, wherein the at least one system, device, and/or network includes at least one diagnostic system, device, or network.

18. The preform according to claim 17, wherein the at least one system, device, and/or network includes at least one fabric diagnostic system, device, or network.

19. The preform according to claim 1, wherein the at least one system, device, and/or network includes at least one magnetic component.

20. The preform according to claim 1, wherein the at least one system, device, and/or network includes at least one component for releasing a medication.

21. The preform according to claim 1, wherein the at least one system, device, and/or network includes at least one component for repairing the preform.

22. The preform according to claim 1, wherein the at least one system, device, and/or network includes at least one audio component.

23. The preform according to claim 1, wherein the at least one system, device, and/or network includes at least one video component.

24. The preform according to claim 1, wherein the at least one system, device, and/or network includes at least one receiver and/or transmitter components.

25. The preform according to claim 1, where the 3-D fabric or preform is to be used for its own purpose or without being included in further composite processes.

26. The preform according to claim 1, wherein the preform is formed from a 3-D multiaxial woven fabric incorporating more than three directions of fibers/tows, where at least one of them is oriented at an angle to the direction of fabric formation.

27. The preform according to claim 1, wherein the network forms a circuit for the transmission of fluids, electricity, or light.

28. The preform according to claim 1 wherein the network forms a circuit for the transmission of fluids, electricity, or light and which performs logical functions.

29. The preform according to claim 1, wherein the preform is formed from/as a 3-D warp-knitted fabric.

30. The preform according to claim 1, wherein the at least one system, device, and/or network includes at least one optical fiber.

31. The preform according to claim 1, wherein the at least one system, device, and/or network includes at least one piezoelectric fiber or other piezoelectric object substantially extended in one direction.

32. The preform according to claim 1, wherein the at least one system, device, and/or network includes at least one shape memory alloy fiber or other shape memory alloy object substantially extended in one direction.

33. The preform according to claim 1, wherein the at least one system, device, and/or network includes at least one tubular, hollow, or microchannel fiber, rod, or filament.

34. A method for forming a 3-D preform for composites comprising the steps of:

providing yarn system component for forming a three-dimensional engineered fiber preform formed by intersecting textile system components; and

providing at least one system, device, and/or network integrated with the preform for providing a predetermined function,

wherein the at least one system, device, and/or network is introduced prior to formation of a composite structure including the preform,

thereby providing a 3-D fabric preform for composites.

35. The method according to claim 34, further including the steps of:

introducing device/network materials to the textile processing system supply for integration with the preform in at least one fiber or pathway of the network materials;

producing the preform via a textile processing system; thereby producing a 3-D fabric having integrated networks/devices therein.

36. The method according to claim 35, wherein the at least one fiber or pathway of the network materials, device and/or sensors is a substantially straight pathway.

37. The method according to claim 35 wherein the at least one fiber or pathway is flexible.

38. The method according to claim 35 wherein the at least one fiber or pathway is rigid.

39. A polymer matrix composite material which is manufactured with the utilization of the preform according to claim 1 using any suitable room temperature or elevated temperature composite fabrication technique.

40. A ceramic matrix, metal matrix and/or carbon matrix composite material which is manufactured with the utilization of the preform according to claim 1 using any suitable processing technique, with the selection of the system, device, and/or network able to maintain its functionality in a respective high temperature processing and/or in-service environment.

* * * * *