



US 20050084388A1

(19) **United States**

(12) **Patent Application Publication**

Hayes et al.

(10) **Pub. No.: US 2005/0084388 A1**

(43) **Pub. Date: Apr. 21, 2005**

(54) **POSITIVE DISPLACEMENT LIQUID PUMP**

(52) **U.S. Cl. 417/222.1; 417/269; 417/505**

(76) **Inventors: Alan E. Hayes, Bend, OR (US); Jerry A. Young, Bend, OR (US)**

(57) **ABSTRACT**

Correspondence Address:
KOLISCH HARTWELL, P.C.
520 S.W. YAMHILL STREET
SUITE 200
PORTLAND, OR 97204 (US)

Pulseless reciprocating pumps that include a control valve that rotationally engages a wear plate, such as the pumps disclosed in U.S. Pat. Nos. 5,718,570 and 5,733,105. The pumps include stiction-inhibiting structures and compositions that adapt the reciprocating pumps for use in delivering liquid streams that contain at least a modest carbon-containing feedstock component, such as one or more alcohols or hydrocarbons. The present disclosure is also directed to embodiments of the above-referenced and incorporated pumps that are adapted to have improved durability and leak-inhibiting structure. Fuel processing and fuel cell systems that include at least one of the disclosed reciprocating pumps are also presented.

(21) **Appl. No.: 10/622,808**

(22) **Filed: Jul. 17, 2003**

Publication Classification

(51) **Int. Cl.⁷ F04B 1/26; F04B 1/12**

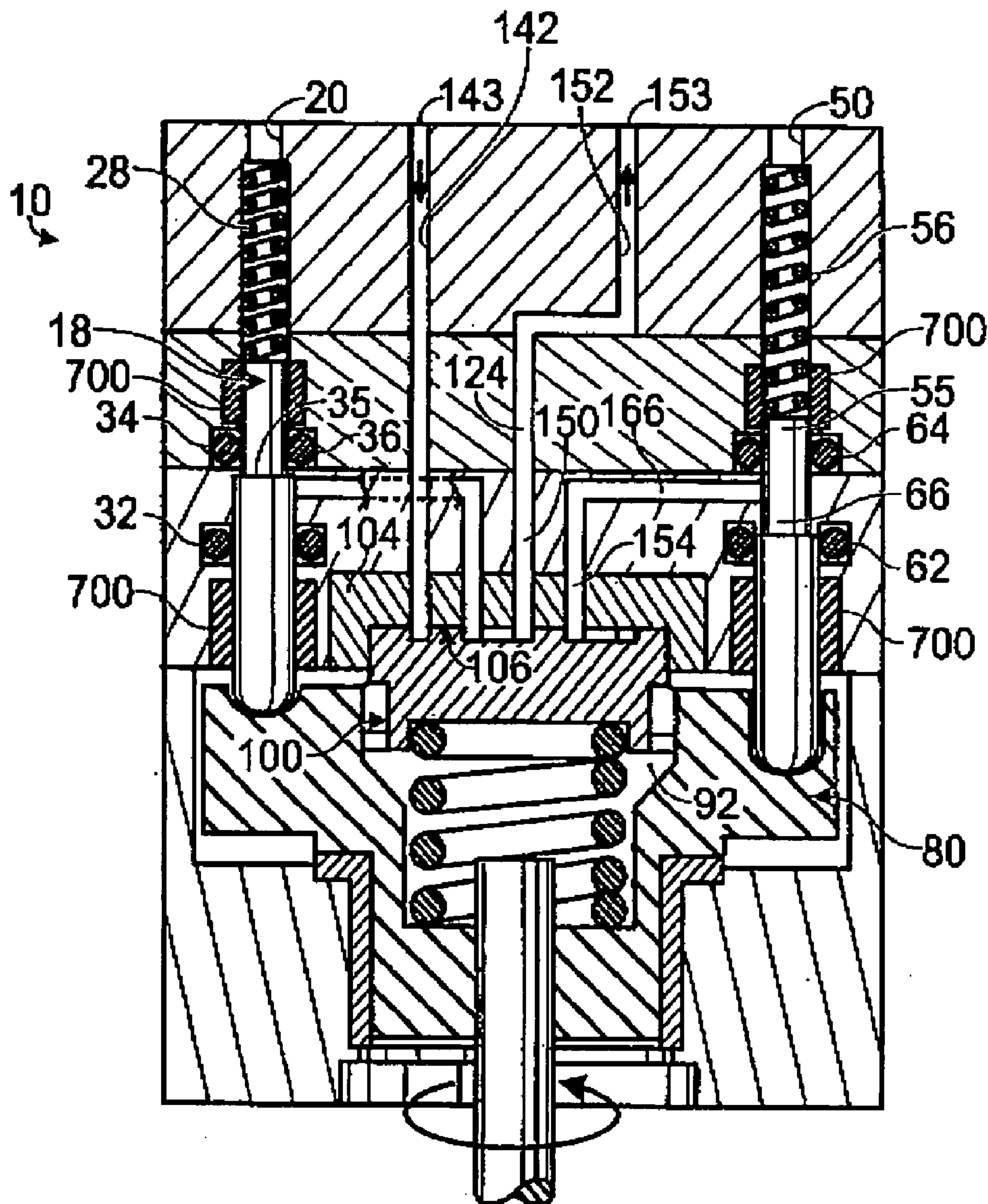

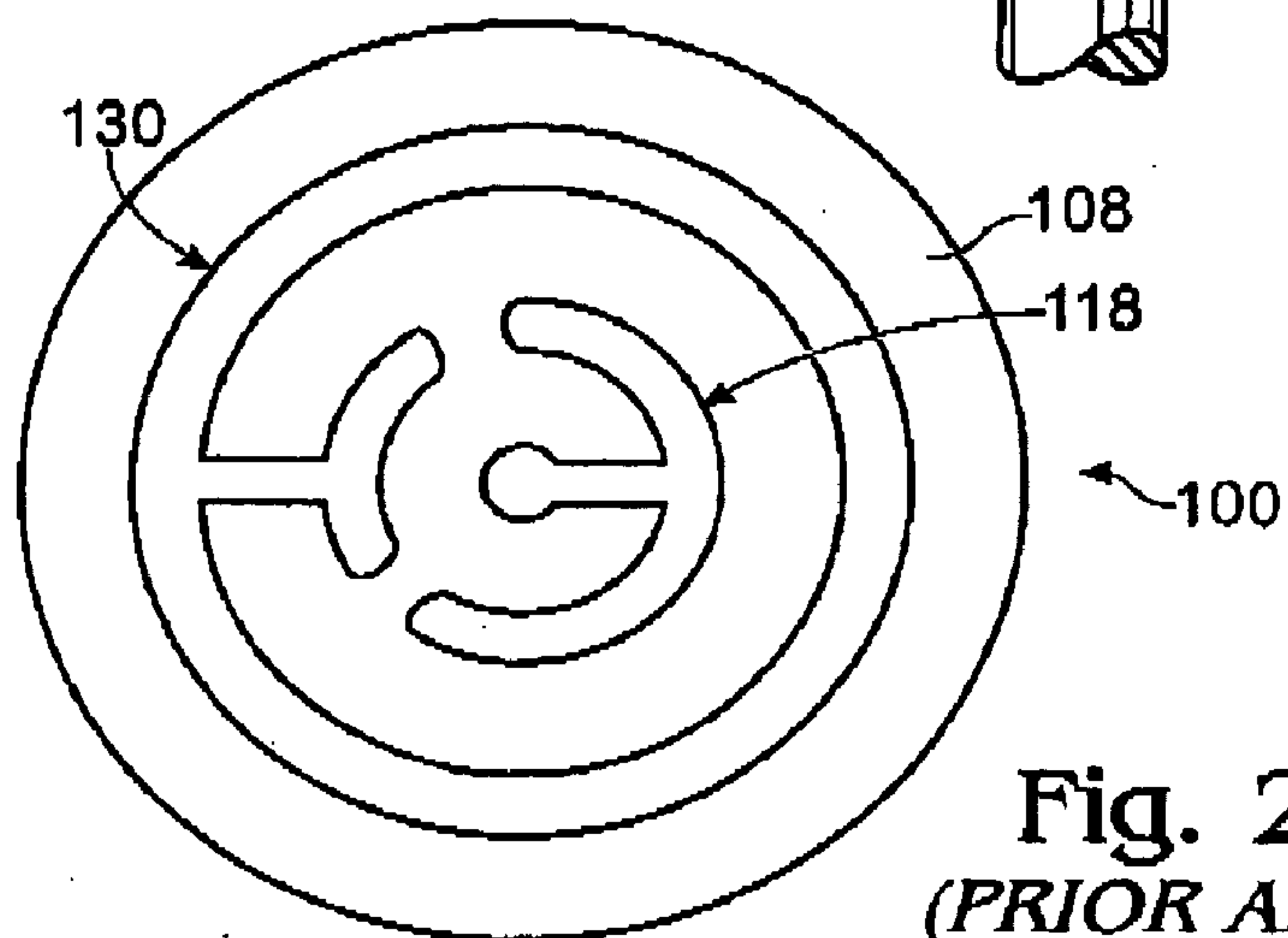
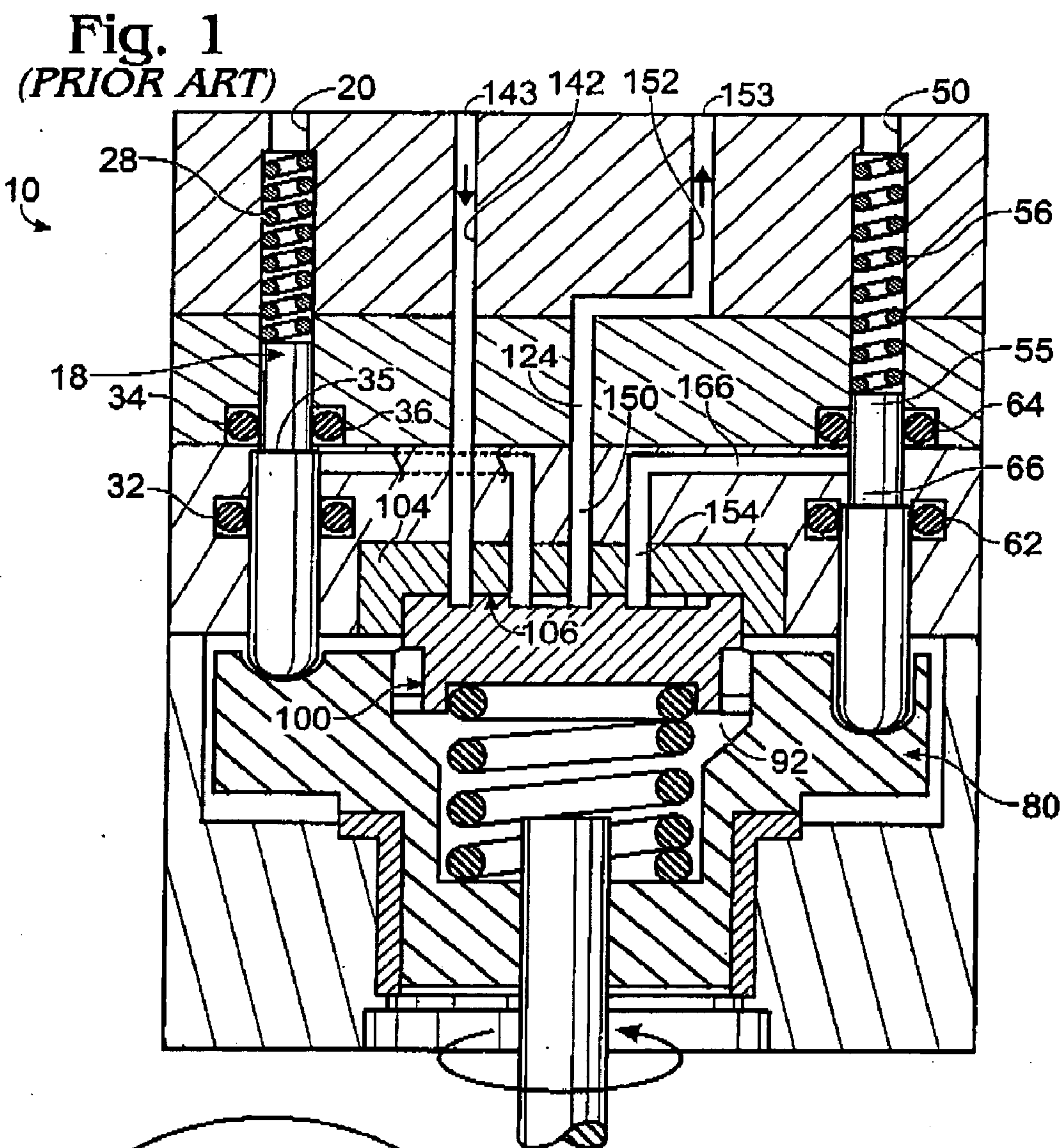

Fig. 2
(PRIOR ART)

Fig. 3
(PRIOR ART)

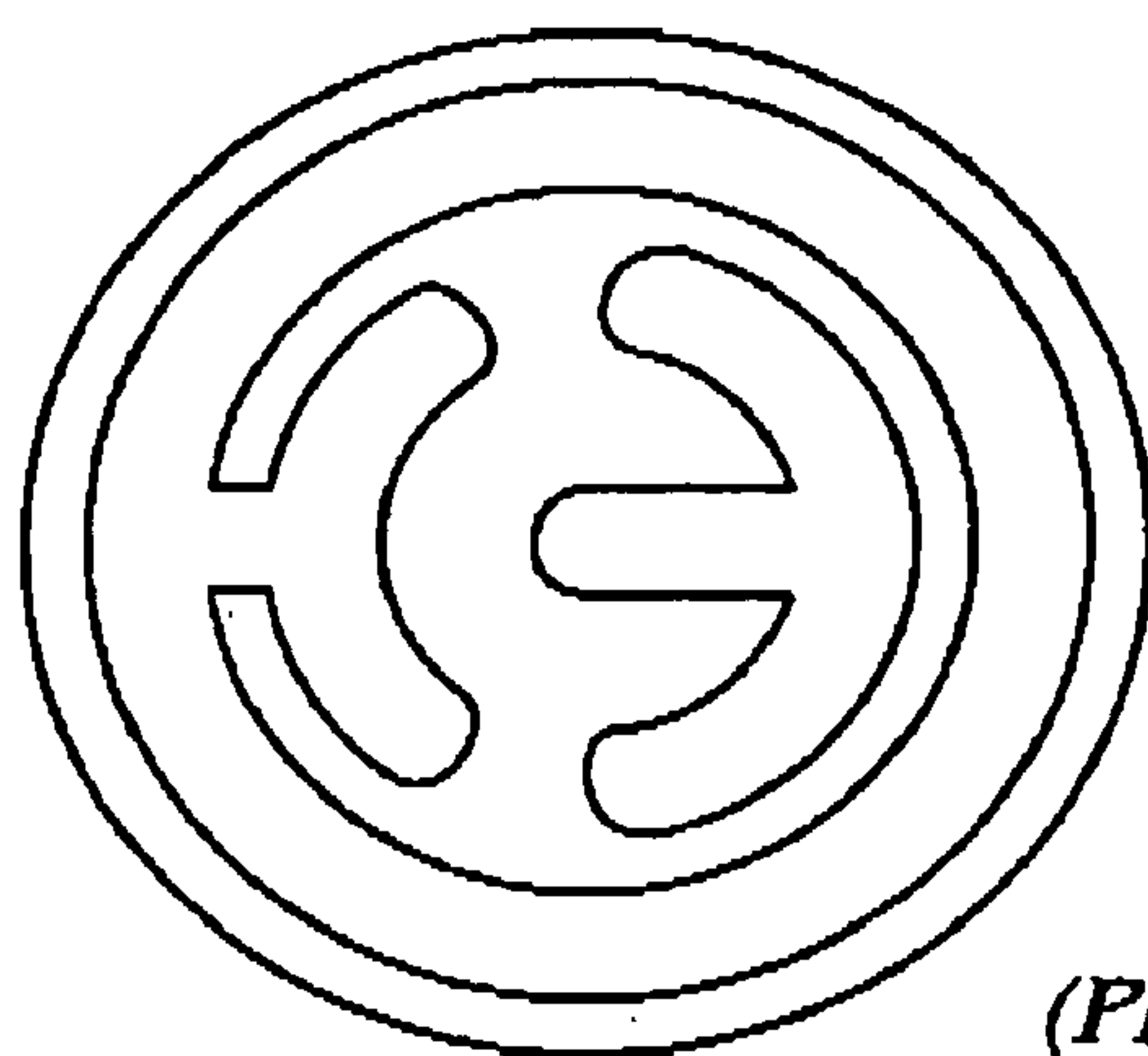
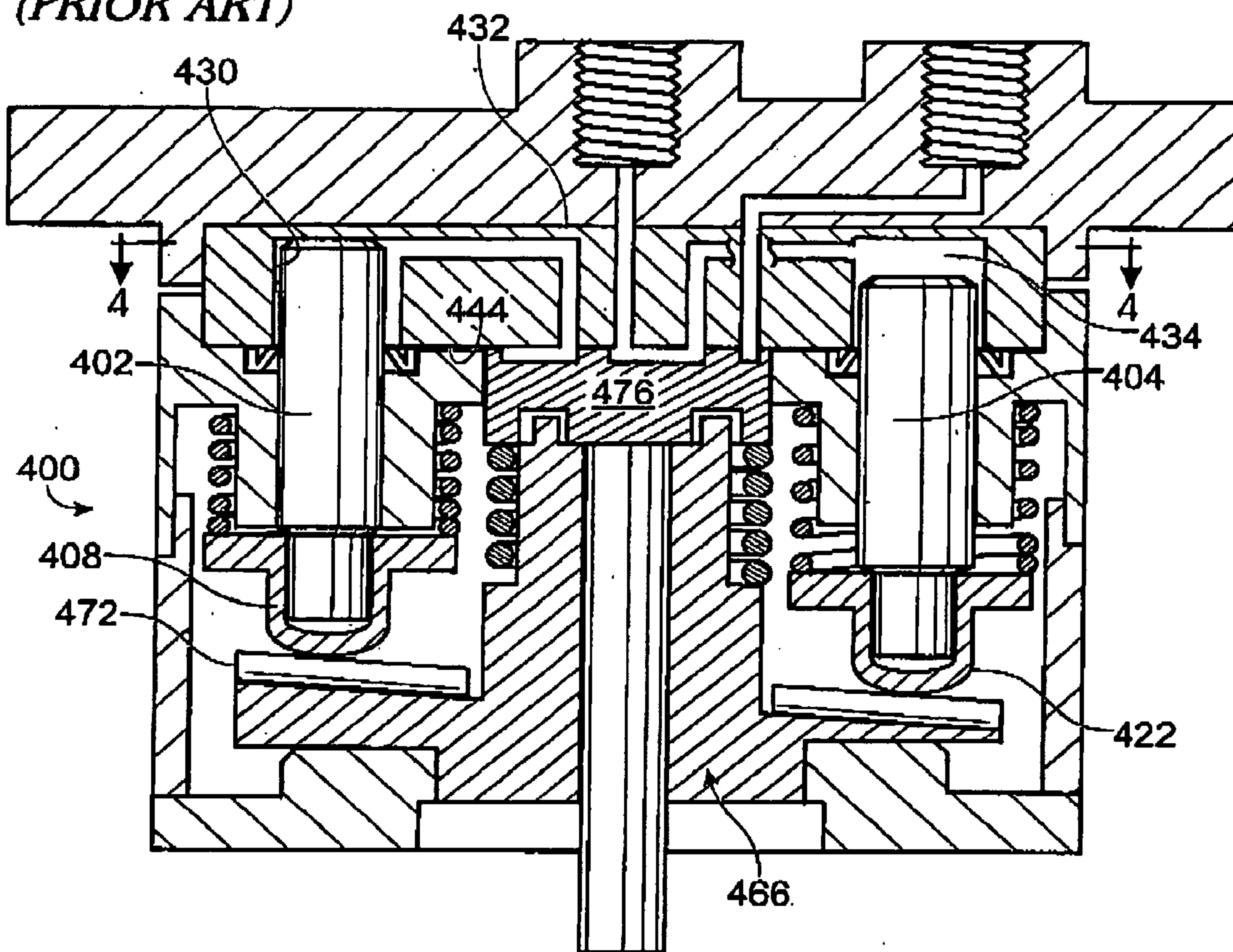

Fig. 4
(PRIOR ART)

Fig. 5

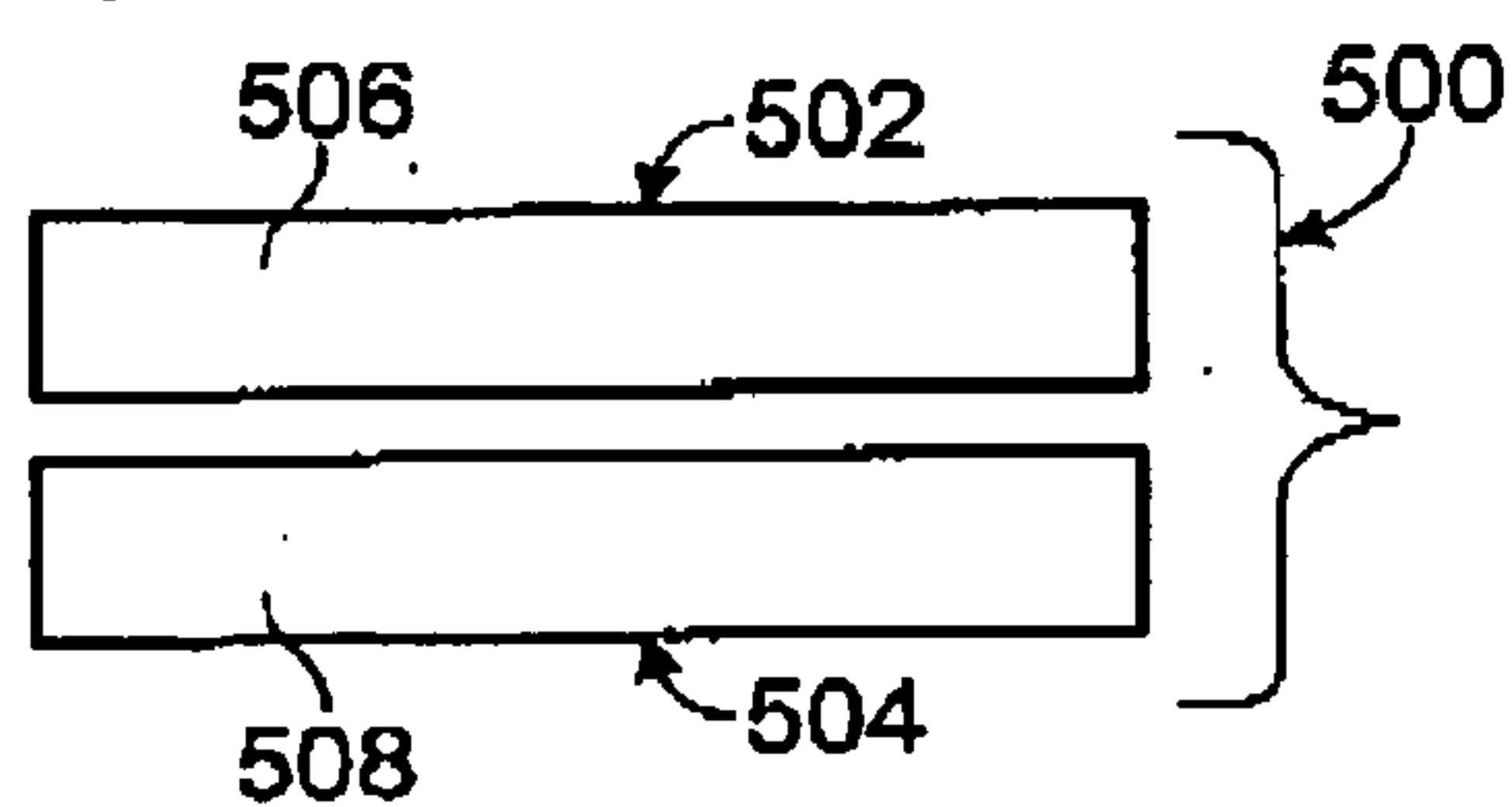

Fig. 6

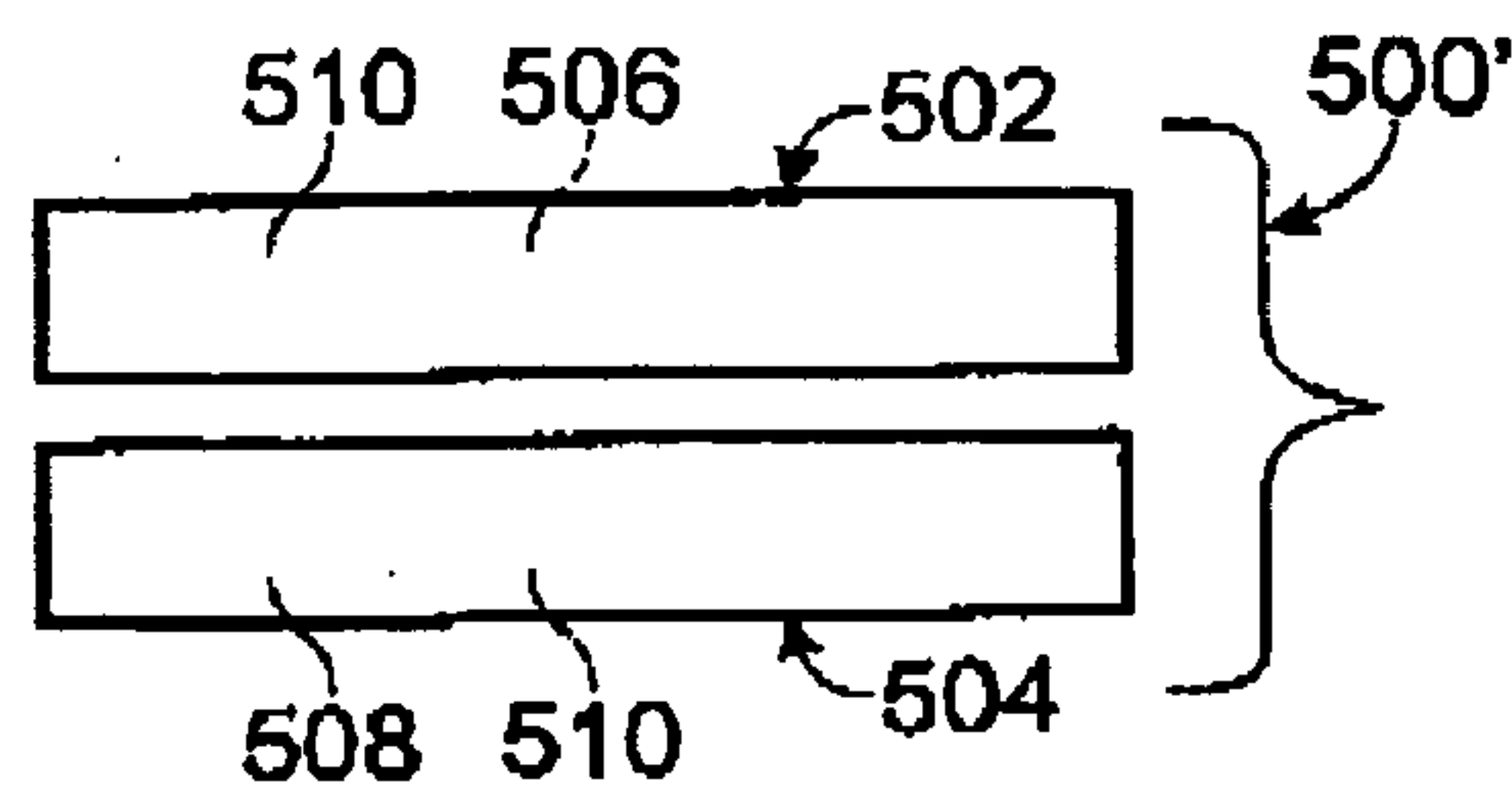

Fig. 7

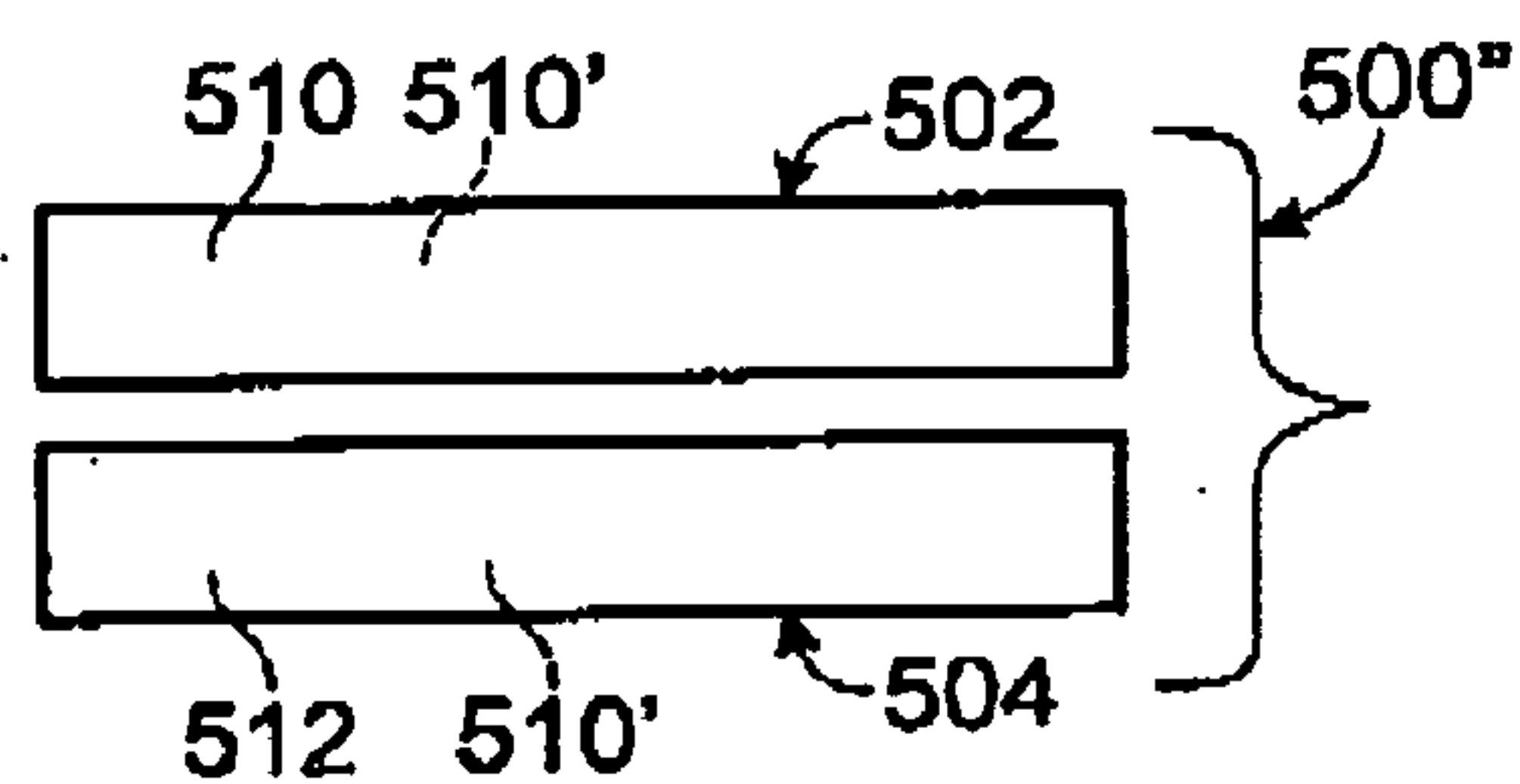

Fig. 8

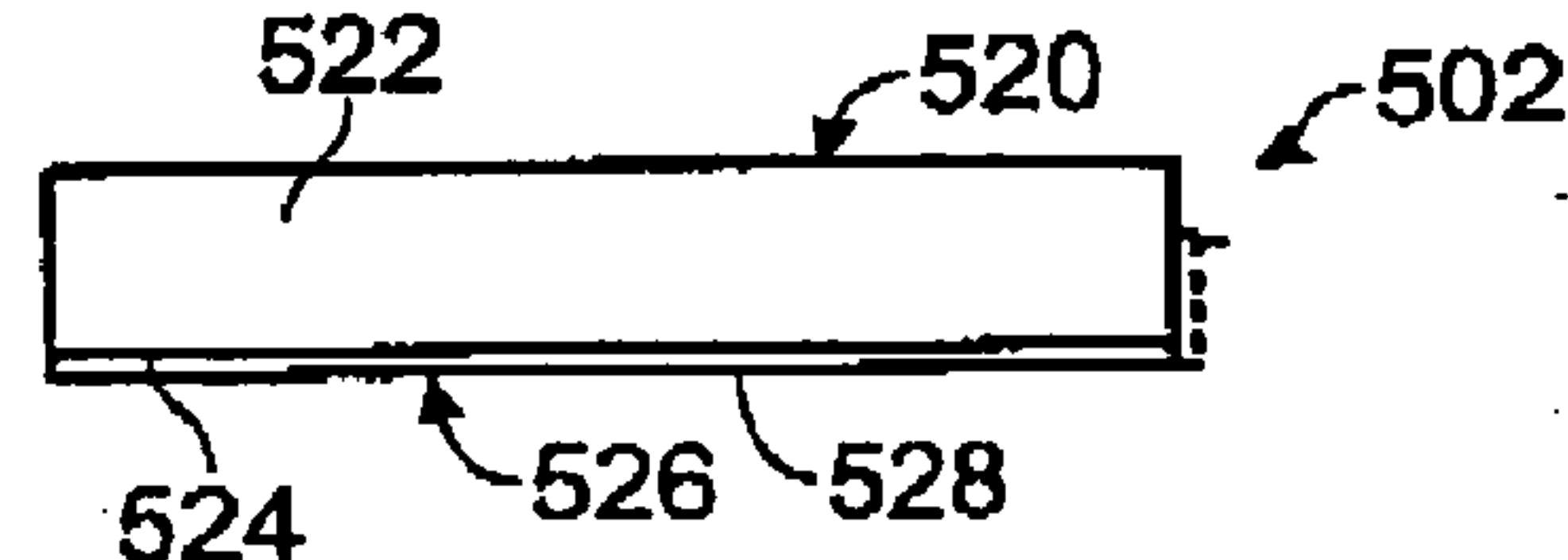

Fig. 9

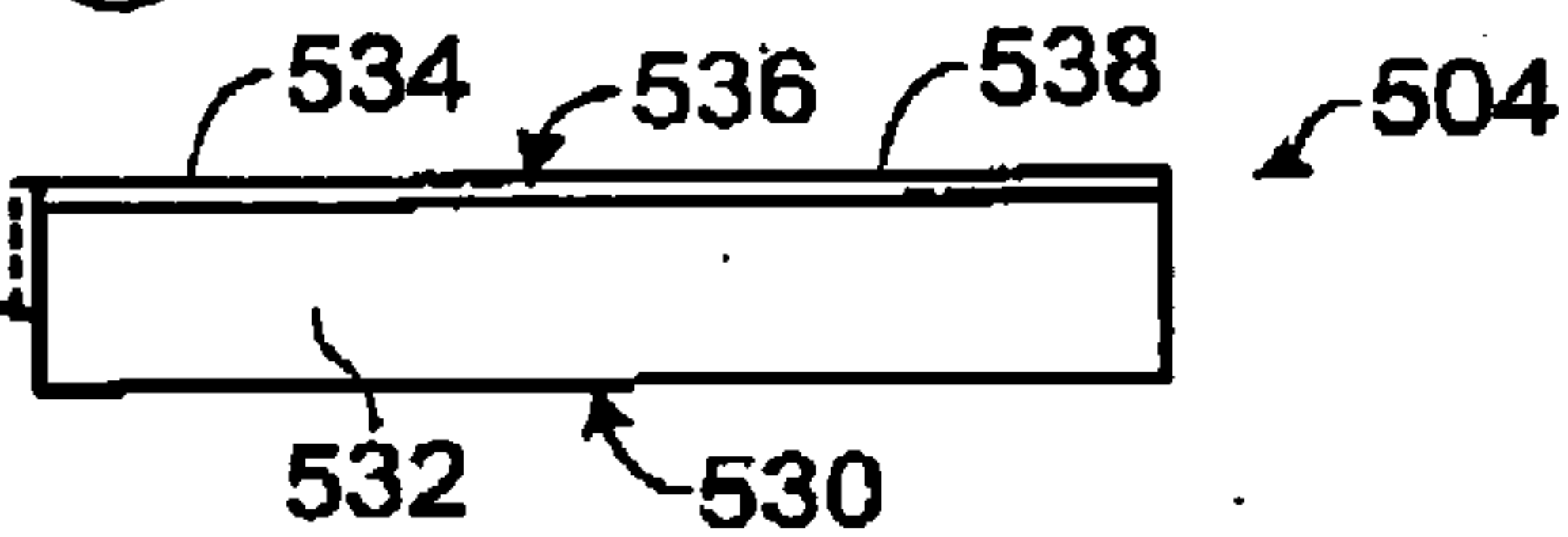

Fig. 10

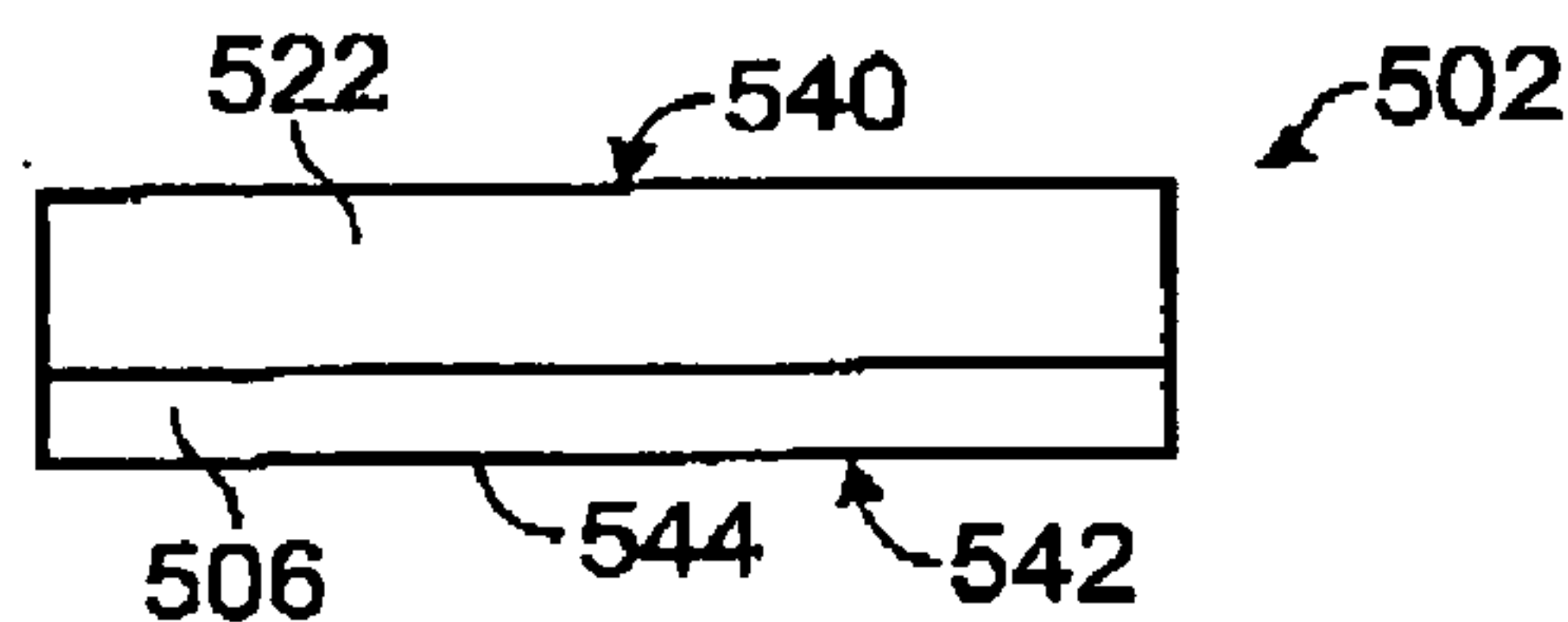

Fig. 11

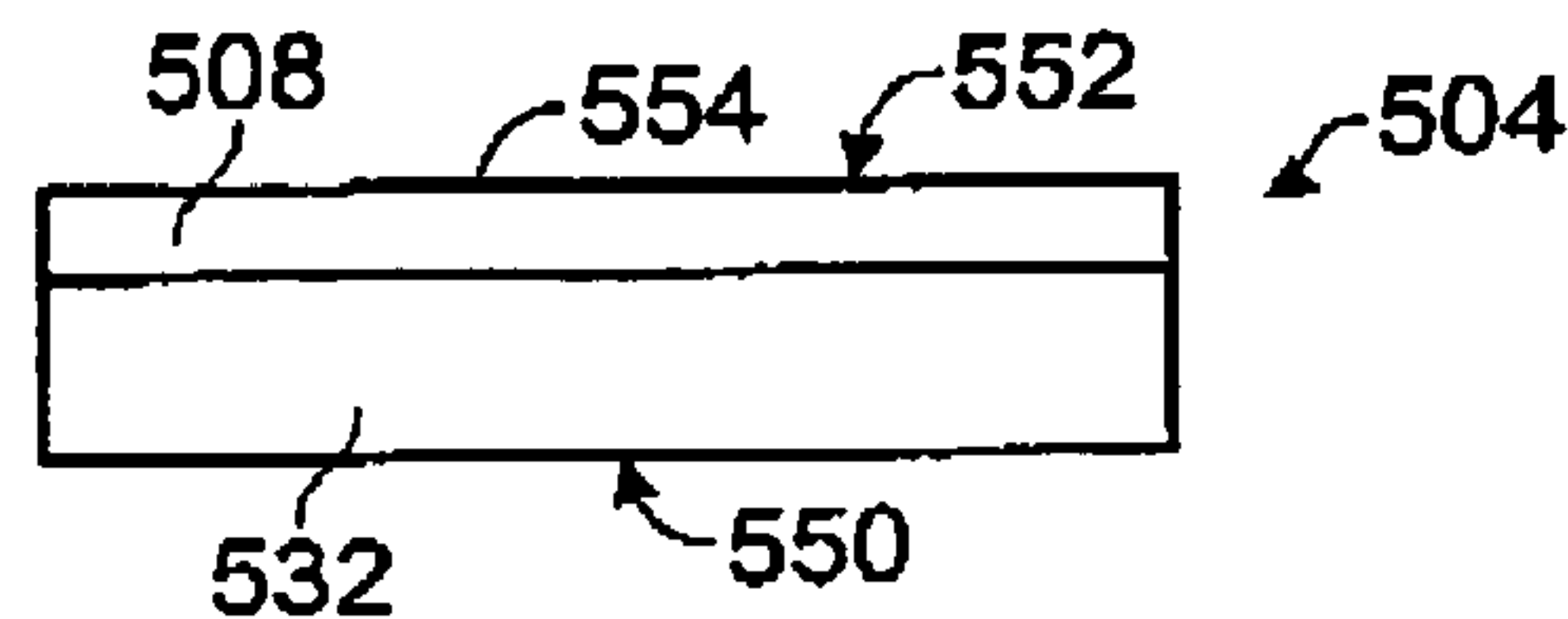

Fig. 12

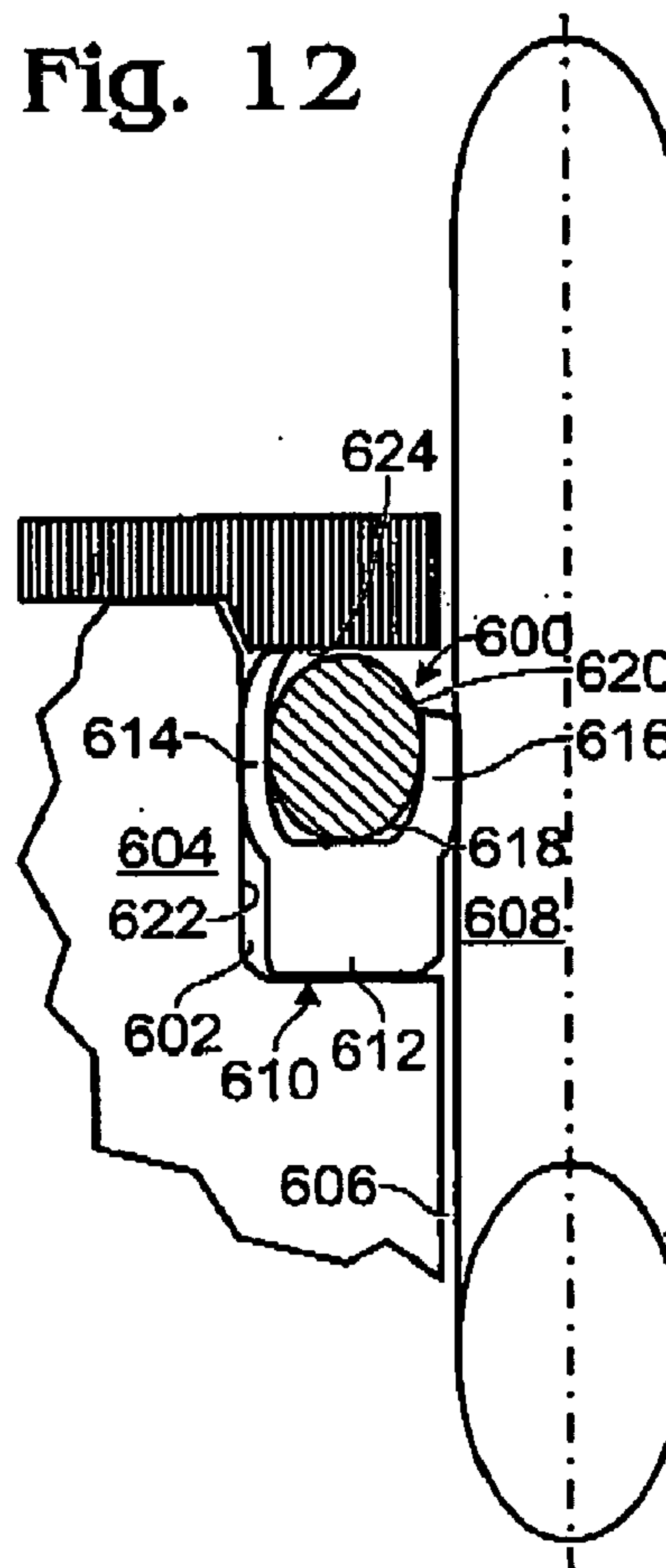

Fig. 13

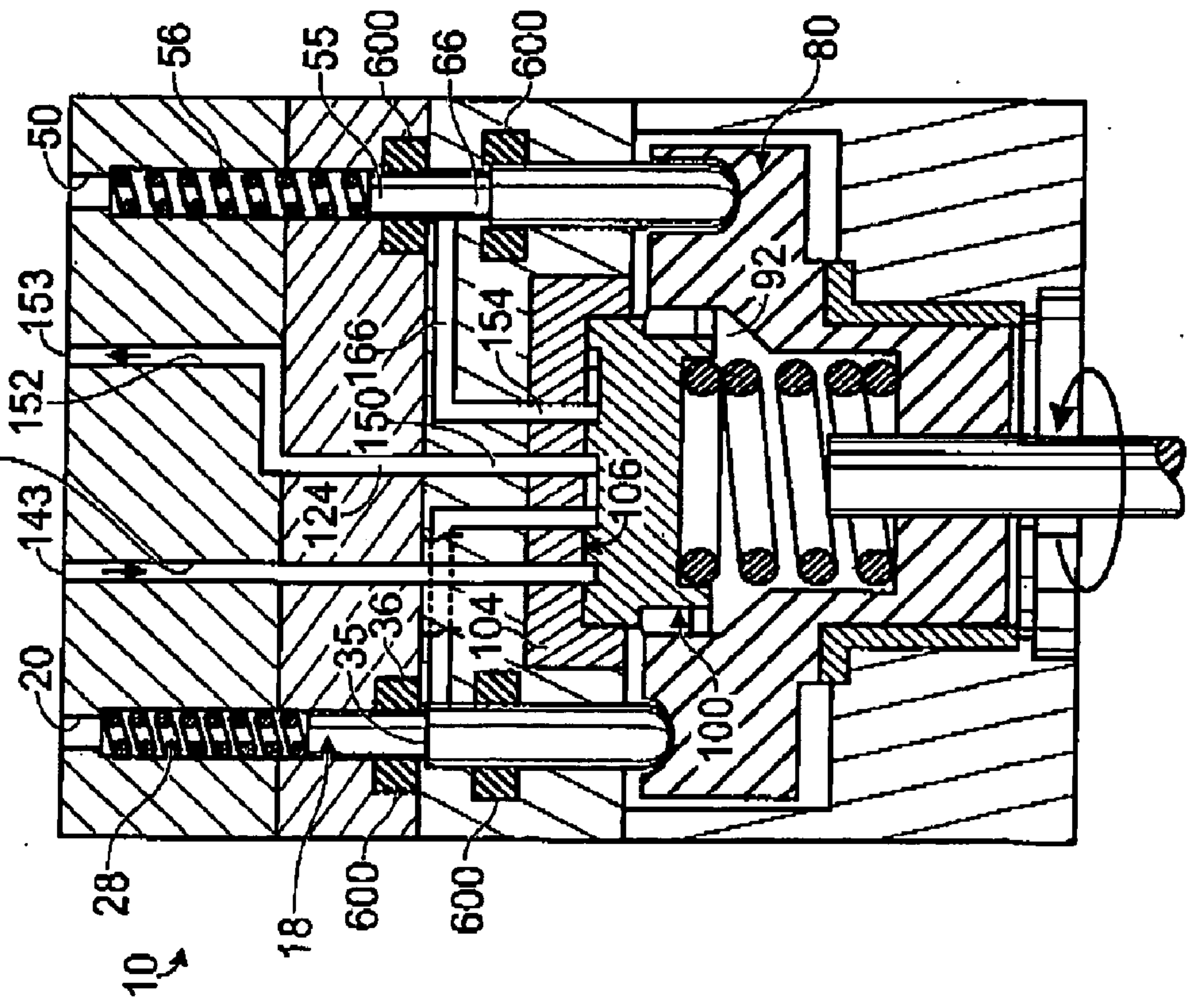

Fig. 14

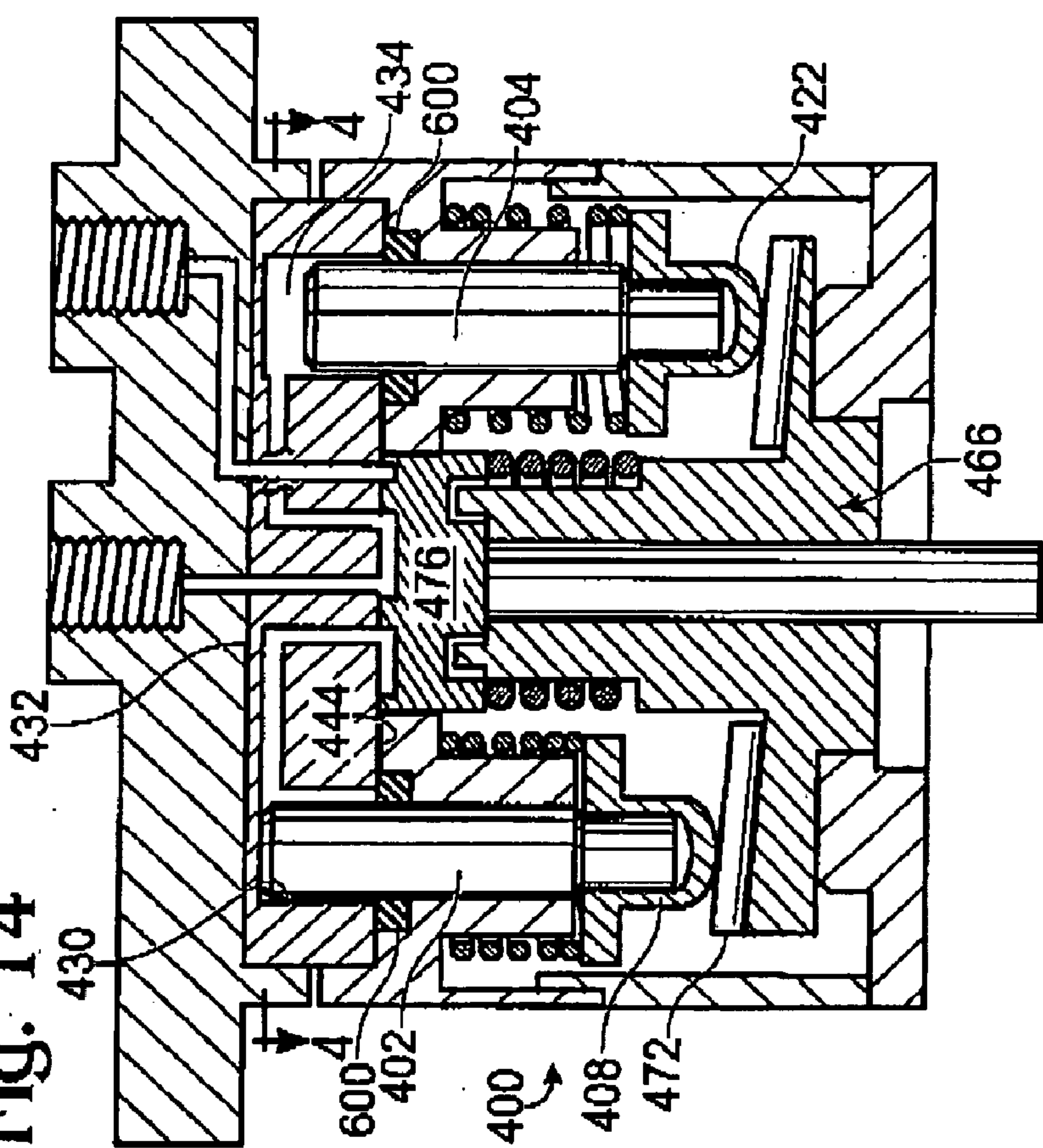

Fig. 17

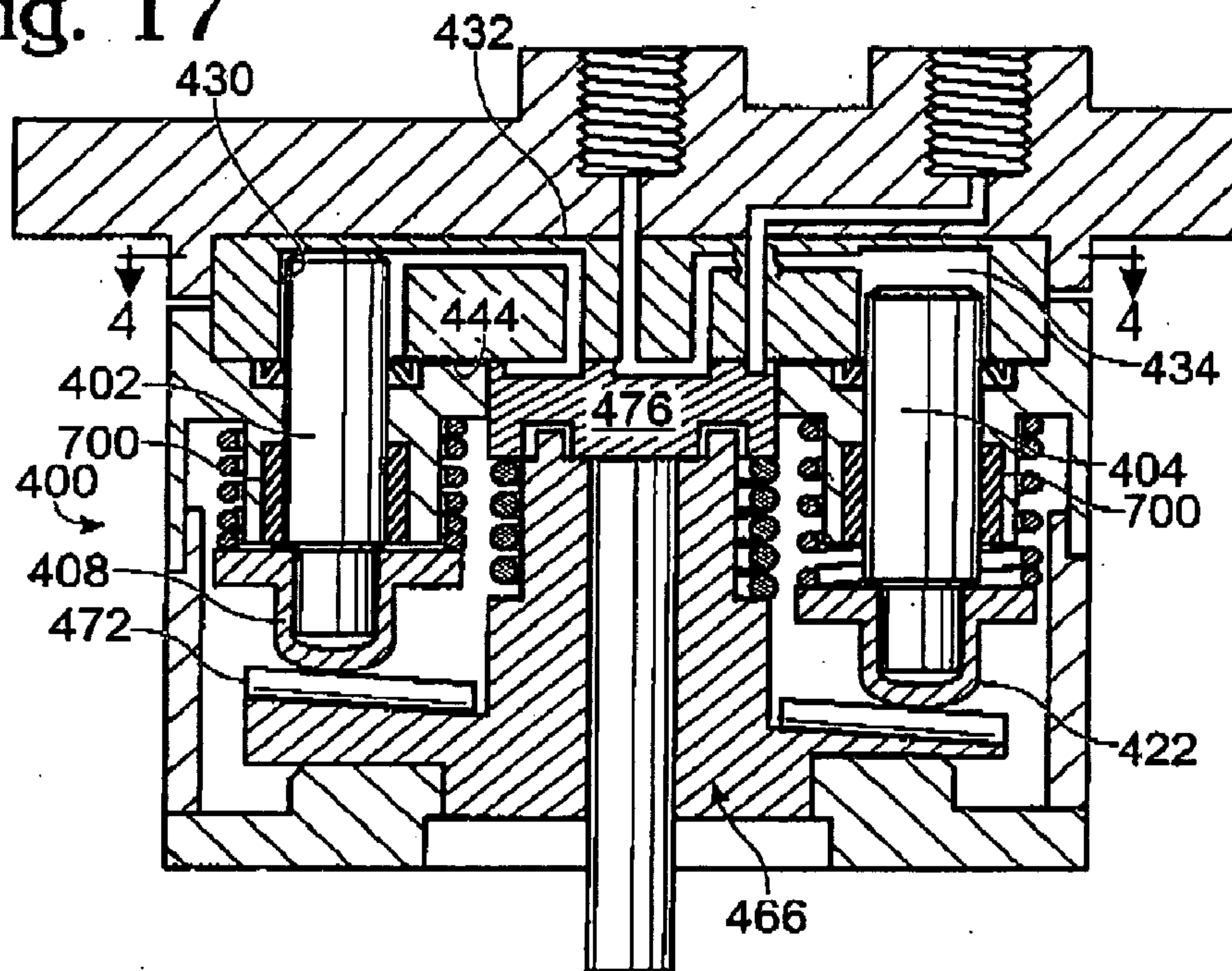

Fig. 18

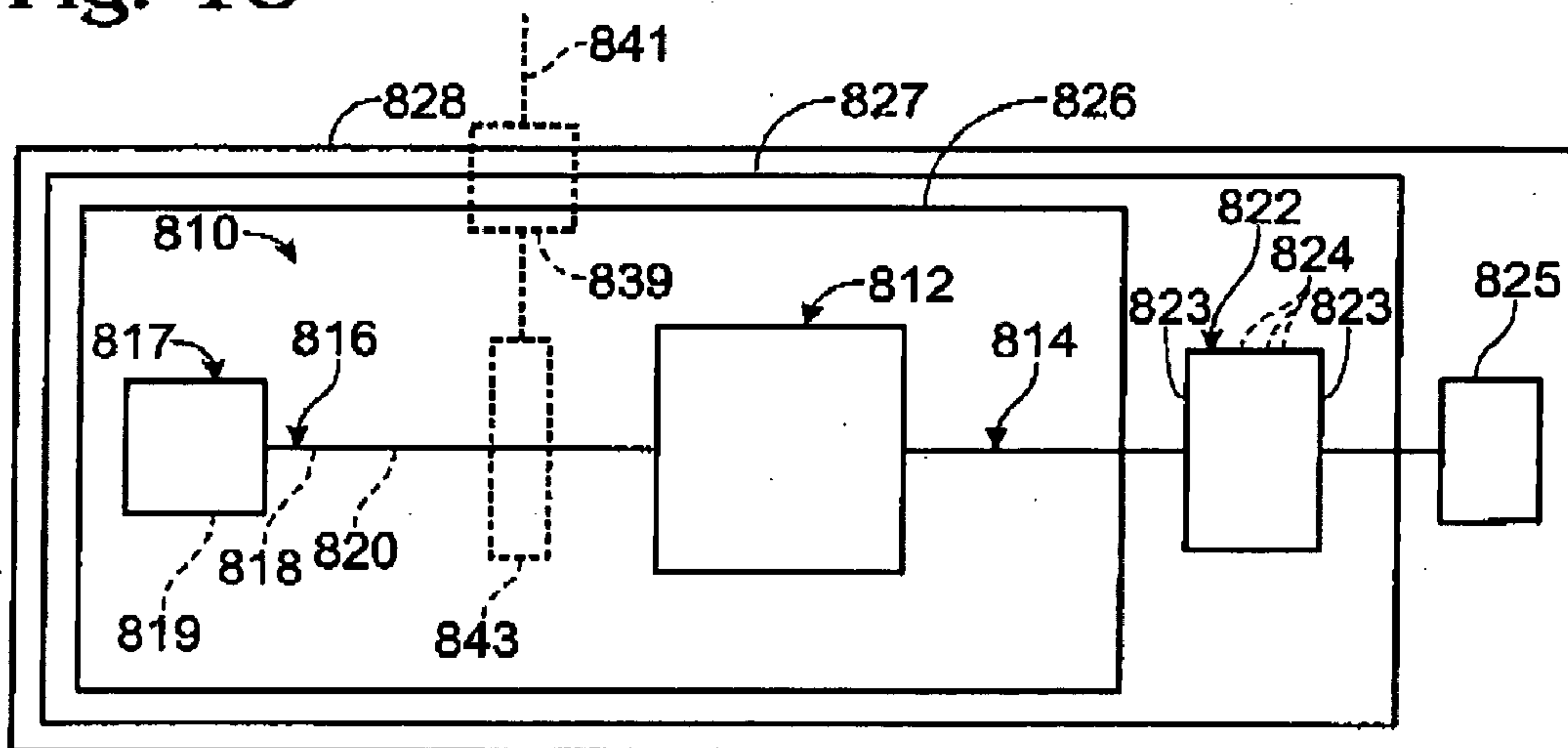

Fig. 19

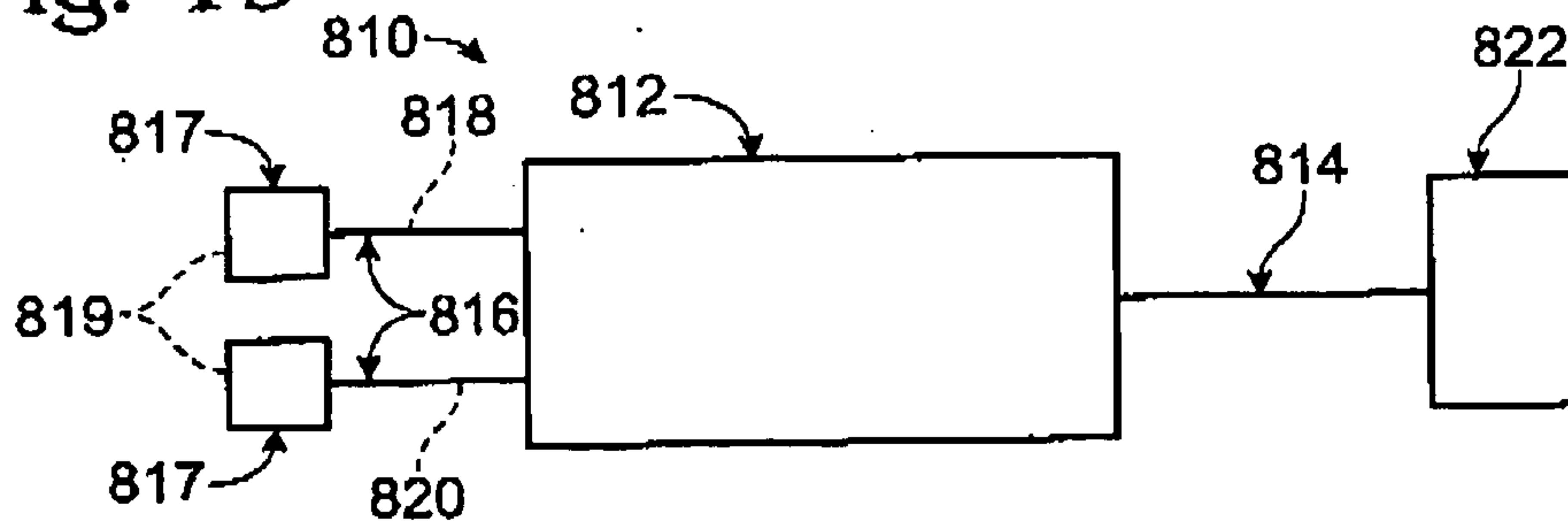

Fig. 20

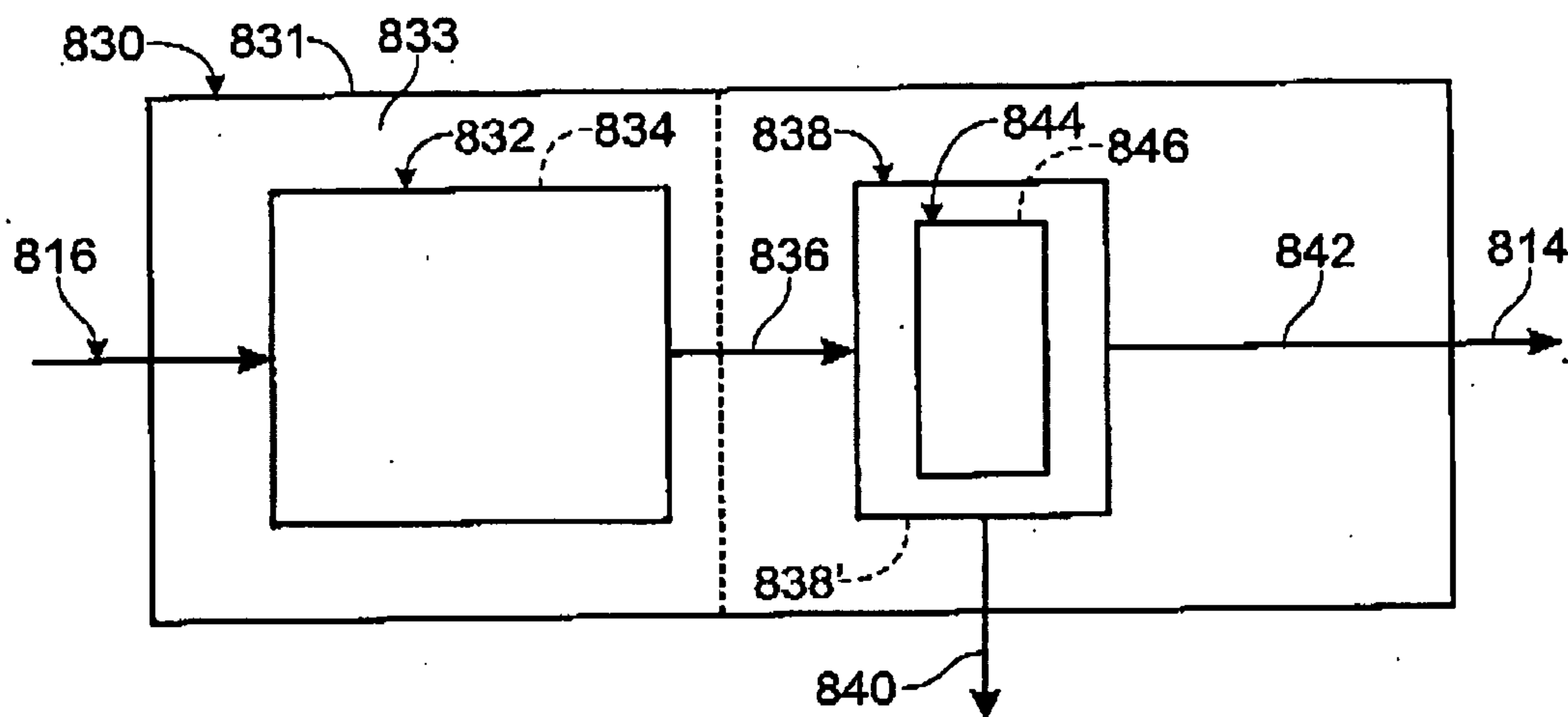
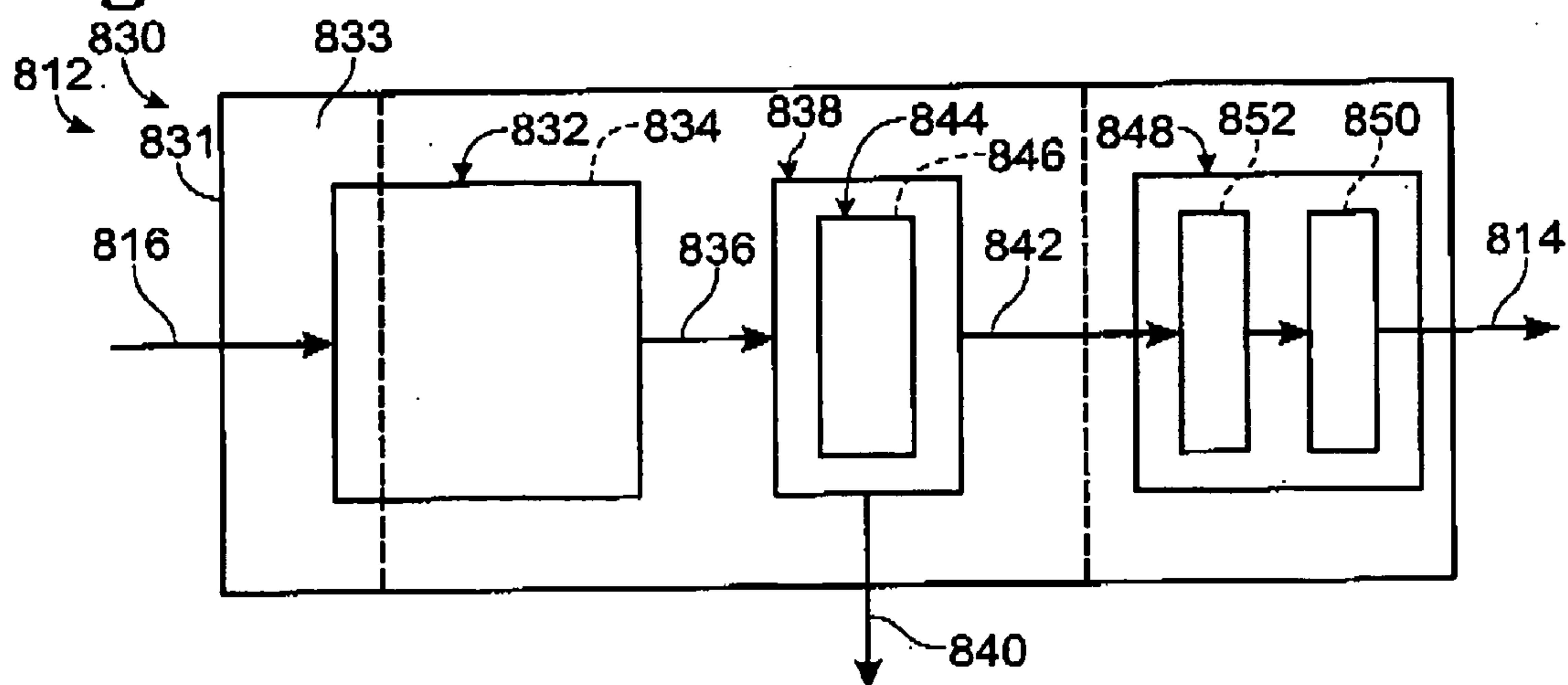

Fig. 21



POSITIVE DISPLACEMENT LIQUID PUMP

RELATED APPLICATION

[0001] This application is a non-provisional patent application that claims priority to co-pending and similarly entitled U.S. Provisional Patent Application Ser. No. 60/396,934, which was filed on Jul. 17, 2002 and the complete disclosure of which is hereby incorporated by reference for all purposes.

FIELD OF THE DISCLOSURE

[0002] The present disclosure is directed generally to liquid pumps and more particularly to positive displacement liquid pumps.

BACKGROUND OF THE DISCLOSURE

[0003] U.S. Pat. Nos. 5,718,570 and 5,733,105 to Beckett et al. (which are referred to herein as “the Beckett patents”) disclose positive displacement liquid pumps that are configured for pulseless delivery. The complete disclosures of these patents are hereby incorporated by reference for all purposes. The Beckett patents disclose pumps that are suitable for use in compact environments. Furthermore, the disclosed pumps are configured to provide a near continuous (pulseless) delivery, which is favorable for many applications. A distinction between the pumps disclosed in the Beckett patents and conventional positive displacement liquid pumps is that the pumps deliver liquid under pressure without requiring the check valves that are conventionally used to provide the flow of the liquid output.

[0004] FIGS. 3 and 5 of the Beckett patents are reproduced as FIGS. 1 and 2, respectively. As shown, the pump 10 takes the form of a reciprocating, dual-piston pump. The pump includes a rotating cam 80 that reciprocates a pair of spring-biased pistons 18 and 55 against forces exerted by springs 28 and 56 to selectively draw liquid into (and expel from) corresponding pump chambers 36 and 66. As shown, each piston is supported with its corresponding bore 20 or 50 and includes a pair of seals (32 and 34 or 62 and 64) that are adapted to prevent fluid from leaking from the corresponding pumping chambers 36 and 66. As the pistons reciprocate within their bores, liquid to be pumped is drawn into the pump through inlet 143 (and corresponding inlet conduit 142) and fluid is expelled through outlet 153 (and corresponding outlet conduit 152).

[0005] The pump further includes a control valve 100 that extends against, and rotates relative to, a wear plate 104. As perhaps best seen in FIG. 2, valve 100 includes a bearing surface 108 that is intended to establish a fluid-tight seal with a corresponding bearing surface 106 of the stationary wear plate. The control valve is carried and rotated by the cam that reciprocates the pistons. By referring back to FIG. 1, it can be seen that the control valve and wear plate collectively define a series of fluid passageways that periodically align as the control valve is rotated relative to the wear plate. The selective alignment of respective passageways controls the delivery of fluid under pressure from the pump's input and output conduits. As perhaps best seen in FIG. 2, control valve 100 includes a pair of groove complexes 118 and 130 that selectively establish fluid communication between the respective pumping chambers and inlet/outlet conduits as the control valve is rotated relative to

the wear plate and the pistons are reciprocated within their bores. More particularly, the relative rotational position of the control valve relative to the wear plate enables or prevents liquid flow between grooves in the control valve and the wear plate. In the dual-piston embodiment illustrated in FIG. 1, the periodic alignment of these groove complexes enables the valve to take advantage of alternating pumping actions from plural pistons so that the valve is aligned to deliver liquid via an expelling piston at all times, and thus facilitate a pulseless (or near pulseless) delivery of liquid. A more detailed description of the structure of pump 10 is contained within the Beckett patents, the disclosure of which is incorporated by reference herein.

[0006] Another example of a reciprocating pulseless pump that is disclosed in the '105 Beckett patent is shown in FIG. 3, with the control valve of that pump shown in FIG. 4. FIGS. 3 and 4 correspond to FIGS. 11 and 12 of the '105 Beckett patent, the disclosure of which is also incorporated by reference herein. Accordingly, and for the purpose of brevity, the entire description of the components and operation of pump 400 is not repeated herein. However, and as shown in FIGS. 3 and 4, pump 400 is similar in operation to the previously described pump 10. For example, the pump includes a control valve 476 that is rotated against the inner control surface 444 of a wear, or control, plate 432 to periodically align portions of fluid passageways that cooperate to draw fluid into and expel fluid from pumping chambers 430 and 434. In further similarity to pump 10, pump 400 includes a pair of spring-biased pistons 402 and 404 that are urged against the biasing force of their respective springs as a cam 466 is rotated. In the illustrated embodiment shown in FIG. 3, the pistons include bearing caps 408 and 422 and cam 466 includes a wobble plate 472 against which the bearing caps impinge as the cam is rotated. A single seal is also shown extending against each piston to prevent leaks from the corresponding pumping chambers.

SUMMARY OF THE DISCLOSURE

[0007] The present disclosure is directed to improvements to pulseless reciprocating pumps that include a control valve that rotationally engages a wear plate, such as the pumps disclosed in U.S. Pat. Nos. 5,718,570 and 5,733,105. More particularly, the present disclosure is directed to stiction-inhibiting structures and compositions that adapt the above-referenced and incorporated pumps for use in delivering liquid streams that contain at least a modest carbon-containing feedstock component, such as one or more alcohols or hydrocarbons. The present disclosure is also directed to embodiments of the above-referenced and incorporated pumps that are adapted to have improved durability and leak-inhibiting structure.

BRIEF DESCRIPTION OF THE DRAWINGS

[0008] FIG. 1 is a cross-sectional view of a prior art liquid pump.

[0009] FIG. 2 is a plan view of a control valve of the pump of FIG. 1.

[0010] FIG. 3 is a cross-sectional view of another prior art liquid pump.

[0011] FIG. 4 is a plan view of a control valve of the pump of FIG. 3.

[0012] FIG. 5 is a cross-sectional view of a valve assembly that contains a wear plate and a control valve constructed according to the present disclosure.

[0013] FIG. 6 is a cross-sectional view of another valve assembly that contains a wear plate and a control valve constructed according to the present disclosure.

[0014] FIG. 7 is a cross-sectional view of another control valve that contains a wear plate and a control valve constructed according to the present disclosure.

[0015] FIG. 8 is a cross-sectional view of another wear plate constructed according to the present disclosure.

[0016] FIG. 9 is a cross-sectional view of another control valve constructed according to the present disclosure.

[0017] FIG. 10 is a cross-sectional view of another wear plate constructed according to the present disclosure.

[0018] FIG. 11 is a cross-sectional view of another control valve constructed according to the present disclosure.

[0019] FIG. 12 is a cross-sectional view of an improved piston seal for pumps constructed according to the present disclosure.

[0020] FIG. 13 is a cross-sectional view of seals according to FIG. 12 implemented in the pump of FIG. 1.

[0021] FIG. 14 is a cross-sectional view of seals according to FIG. 12 implemented in the pump of FIG. 3.

[0022] FIG. 15 is a cross-sectional view of the pump of FIG. 1 containing piston-aligning collars.

[0023] FIG. 16 is another cross-sectional view of the pump of FIG. 1 containing piston-aligning collars.

[0024] FIG. 17 is a cross-sectional view of the pump of FIG. 3 containing piston-aligning collars.

[0025] FIG. 18 is a schematic diagram of a fuel cell system containing a fuel processor and feedstock delivery system according to the present disclosure.

[0026] FIG. 19 is a schematic diagram of another embodiment of the fuel cell system of FIG. 18.

[0027] FIG. 20 is a schematic diagram of a fuel processor suitable for use in the fuel cell systems of FIGS. 18 and 19.

[0028] FIG. 21 is a schematic diagram of another embodiment of the fuel processor of FIG. 20.

DETAILED DESCRIPTION AND BEST MODE OF THE DISCLOSURE

[0029] By way of background, reciprocating pulseless pumps, such as those described and incorporated herein, include a control valve that rotatingly engages a wear plate, or control plate, to control the delivery of liquid from the pump. The wear plate may also be described herein as a cover, or wear surface, for the control valve. The control valve includes grooves that are in fluid communication with portions of fluid passageways that extend to the control valve. As the control valve is rotated relative to the wear plate, the grooves selectively and fluidly interconnect these portions of fluid passageways with corresponding portions of fluid passageways in the wear plate.

[0030] It should be understood that the junction, or interface, between the control valves and wear plates of pumps such as those described above must be very tight in order to prevent leaks between these components. During operation, the control valve and the wear plate inflict frictional forces on one another as the control valve rotates, or is attempted to be rotated, relative to the wear plate. Accordingly, a design criterion for the control valve and wear plate is the pressure of the liquids to be pumped therethrough. For example, liquids may travel through the grooves in the control valve at pressures in the range 100-250 psi, such as at approximately 200 psi. The pressure of this liquid will tend to urge the control valve away from the wear plate. As such, the control valve needs to be urged against the wear plate with sufficient force to withstand this pressure. Similarly, the control valve must be designed to be able to withstand forces applied by this pressurized liquid that will tend to distort or deform the control valve. This distortion or deformation may permit liquid from within a groove of the control valve to leak, such as to another groove or outside of the control valve.

[0031] Related to this strength-of-materials discussion is the fact that the control valve and wear plate should be formed from materials that will retain their dimensional integrity and surface of contact after many hours of use. As discussed, the control valve is urged against the wear plate and is rotated relative to the wear plate. If the control valve and wear plate are not formed from sufficiently durable and strong materials, the contact between the components as the pump is used will create wear in the components that can reduce the structural integrity of the components and/or the surface of contact between the components. Either or both of these outcomes may cause or lead to leaks or failure of the pump. Therefore, the materials used to form these components preferably are high-strength materials that are sufficiently durable to be used for prolonged useful lives (such as at least 10,000, 30,000, 50,000 or more hours) without failing, such as due to uneven or excessive wear.

[0032] Conventionally, the engaging, or bearing, surfaces of the control valve and wear plate are highly finished, such as to a few millionths of an inch to provide a high surface contact between the opposed surfaces. It should be understood that a high level of surface contact between the rotating surfaces helps prevent leaks between the surfaces. However, the high surface contact between these surfaces also can be detrimental to the operation of the pump because it may result in these surfaces sticking together. Described in other words, the torque applied to the control valve may be insufficient to overcome the frictional or other forces that inhibit rotation of the control valve relative to the wear plate. These forces are referred to herein as "stiction" forces. Stiction is a coined term ("stick" plus "friction") that is used to describe the interfacial adhesion between contacting surfaces, and which may also generally include a variety of sticking problems between contacting surfaces. Such failures can be very damaging, not only to the pump, but also to devices and/or systems that are relying on the delivery (pulseless or otherwise) of liquids from the pump when the pump fails.

[0033] Problems due to seizing of the control valve may be amplified by the type of liquid that is pumped therethrough. For example, pumps are conventionally designed with a predetermined lubricity basis, or reference point, for

the liquid to be pumped. Lubricity refers to the fluid's viscosity as well as its ability to coat a solid structure, such as the control valve or wear plate. When a liquid has good adherence to solid surfaces, it will tend to coat those surfaces. When the coated surfaces are thereafter rotated relative to each other, the liquid phase that coats the surfaces will shear instead of the solid surfaces shearing against each other. When the liquid does not have good adherence to the surfaces, it is the solid surfaces that will tend to be in direct shearing contact with each other. For example, if water is considered to have a lubricity value of 1, a liquid with a lower lubricity value will tend to be more likely to cause the control valve to seize. Illustrative, non-exclusive examples of such liquids include many organic solvents, such as alcohols and many shorter chain hydrocarbons, such as hydrocarbons with less than six carbon atoms. For example, methanol and ethanol both are more likely to cause seizure of the control valve than water. As an illustrative example, methanol has a comparative lubricity value of 0.05 compared to water. In fact, it has been discovered that methanol and other organic solvents, alone or in combination with other liquids, often lead to pump failure due to stiction. Similarly, mixtures (such as solutions containing at least 20, and more commonly at least approximately 33 or 50 mol %) of alcohols and water also are prone to causing seizure of the control valves. As used herein, a liquid to be pumped that is described as containing a modest amount of a carbon-containing feedstock component refers to a stream that contains at least 25 mol % of at least one alcohol, short-chain hydrocarbon or the like.

[0034] An example of applications where such liquid streams are used is in the fuel processing industry, in which hydrogen gas is produced from feed streams containing water and a carbon-containing feedstock. Examples of such carbon-containing feedstocks include alcohols and hydrocarbons. Other fuel processors produce hydrogen gas from carbon-containing feedstocks without water. Pumps such as those described above may be used to deliver at least the carbon-containing feedstock component of these feed streams, and may be used to deliver mixed streams of water and the carbon-containing feedstock component, such as when the carbon-containing feedstock component is miscible in water.

[0035] Conventionally, the control valves and wear plates of the above described and incorporated pumps have been formed from alumina, a high-strength ceramic. While this combination may be effective when water is the fluid to be pumped, this combination has demonstrated a propensity to cause failure of the pump due to stiction when methanol or other alcohols or organic solvents, including solutions of water and one or more alcohols, are pumped. From experiments, this stiction-based failure tends to occur within a relatively short period of operation, such as within 200 hours of operation, but in many cases results essentially within an hour or two of using the pump to pump an organic solvent or solution containing substantial amounts of the same.

[0036] As discussed, alumina is a high-strength ceramic that is able to withstand long periods of rotational contact between control valves and wear plates formed therefrom. However, alumina is a material that is not self-lubricating and has proven to cause seizure of the control valve when methanol or methanol/water mixtures are pumped through the pumps of **FIGS. 1 and 3**.

[0037] Solutions to the stiction or seizing problem discussed above have been difficult to find, at least in part because of the intended use of the control valve and the wear plate. As discussed above, it is important that the two components have a tight interface and retain their configurations when exposed to the operating conditions of the pump (engaging and rotational forces, pressurized liquid, etc.).

[0038] Through experiments, however, it has been discovered that carefully selecting the materials from which the control valve and the wear plate are constructed can prevent seizure of the control valve due to stiction. According to a first aspect of the present disclosure, the control valve and wear plate are constructed from different materials, and preferably from dissimilar materials. As used herein, the term "material" is meant to include uniform compositions, homogenous mixtures of two or more compositions, non-homogenous mixtures of two or more compositions, and composites of two or more compositions. Examples of dissimilar materials include, but should not be limited to, metals, ceramics and polymers. Of course, these materials also must satisfy the strength and wear characteristics discussed above. Similarly, the materials must be resistant, or stable, when exposed to the operating conditions and liquids encountered by the pumps. In the context of pumps for at least alcohols, short chain hydrocarbons and other organic solvents, alumina is an example of a suitable ceramic so long as both components are not formed from alumina or a similar material. Examples of suitable metals include titanium and stainless steel, including Nitronic® stainless steels (high chromium and nickel stainless steels available from AK Steel). Examples of suitable polymers include polyimides and acetals. Examples of suitable polyimides include Vespel®, a family of polyimide resins available from DuPont, including Vespel® SP-1 (unfilled), SP-21 (graphite-filled), SP-22 (40% graphite for increased wear resistance), SP-211 (Teflon (10%) and graphite (15%) filled for reduced friction), and SP-3 (molybdenum-filled). Examples of suitable acetals include as Celcon® (a family of copolymer acetyl resins available from the Celanese Plastics Company), Ensital® (a homopolymer acetyl material available from Ensinger), Ensital®(SD (a static dissipative acetal), Delrin® AF (a Teflon-filled acetyl fluorocarbon homopolymer resin available from the DuPont Company), Delrin® CL (a chemically lubricated homopolymer acetyl resin available from the DuPont Company), Isoplast® (an amorphous resin available from Dow), Questra® (a crystalline polymer available from Dow), Ultem® 1000 (a polyetherimide high-strength polymer available from GE Polymers), and Ultem® 2200 (a glass-filled polyetherimide available from GE Polymers).

[0039] Illustrative examples of properties of some of the above-mentioned polyimide materials are presented in the following table. It is within the scope of the disclosure that other materials having one or more selected characteristics within the range or thresholds illustrated in the table may be used. Similarly, it is also within the scope of the disclosure that materials meeting the characteristics described herein may be used even if one or more selected characteristics of those materials are outside the bounds of the illustrative properties presented in the following table.

TABLE 1-continued

Properties of Polyimide Materials									
Vespel ® Material									
M = machined, DF = direct formed									
Property	SP-1 (M)	SP-1 (DF)	SP-21 (M)	SP-21 (DF)	SP-22 (M)	SP-22 (DF)	SP-211 (M)	SP-211 (DF)	SP-3 (M)
Deformation Under Load (2000 PSI, 122° F.) (%)	0.14	0.20	0.10	0.17			0.13	0.29	0.12
Dielectric Strength (Volts/mil)	560		250						
Volume Resistivity (Ohm-CM)	10 ¹⁴ -10 ¹⁵		10 ¹² -10 ¹³						
Dielectric Constant (10 ² kHz)	3.62		13.53						
Dielectric Constant (10 ⁴ Hz)	3.64		13.28						
Dielectric Constant (10 ⁶ Hz)	3.55		13.41						

[0040] Illustrative examples of properties of some of the above-mentioned acetal materials are presented in the following table. It is within the scope of the disclosure that other materials having one or more selected characteristics within the range or thresholds illustrated in the table may be

used. Similarly, it is also within the scope of the disclosure that materials meeting the characteristics described herein may be used even if one or more selected characteristics of those materials are outside the bounds of the illustrative properties presented in the following table.

TABLE 2

Properties of Acetyl Materials								
Acetyl Material								
Property	Acetyl and Celcon ®	Acetyl, Chem. Lub.	Acetyl, Teflon filled/ Delrin ® AF	Delrin ®	Vespel ® SP-1	Ensilon ®	Ultem ® 1000	Ultem ® 2200
water absorption (24 hours) (%)	0.25	0.271	0.2	0.25		1.2	0.25	0.19
water absorption (saturation) (%)	0.90	1.000	0.72	0.90		9	1.25	1.1
Tensile Strength (73° F.) (ksi)	10.0	9.5	7.6	10.0		12.4	15.2	20.1
Flexural Strength (73° F.) (ksi)	14.3	13.0	10.5	14.3		14.0	22.0	30.0
Compressive Strength (10% Deflection) (ksi)	18.0	15.5	13.0	18.0		12.0	21.9	28.7
Shear Strength (73° F.) (ksi)	9.5	9.5	8.0	9.5		9.6	15.0	15.0

TABLE 2-continued

Properties of Acetyl Materials								
Property	Acetyl Material							
	Acetyl and Celcon ®	Acetyl, Chem. Lub.	Acetyl, Teflon filled/ Delrin ® AF	Delrin ®	Vespel ® SP-1	Ensilon ®	Ultem ® 1000	Ultem ® 2200
Impact Strength, Notched Izod (73° F.) (ft- lbs/in)	1.5	1.4	1.0	1.5		1.2		9
Elongation at Break (73° F.) (%)	60	40	22	60		90	60	3
Tensile Modulus of Elasticity (73° F.) (ksi)	450	450	420	450		400	430	1,000
Flexural Modulus of Elasticity (73° F.) (ksi)	425	400	340	425		410	480	900
Hardness - Rockwell & Brinell (73° F.)	R120	R120	R118	R120		R120	M109	M114
Density (lbs/in)	0.051	0.053	0.051	0.051		0.041	0.045	0.051
Coefficient of Friction (Dynamic)	0.25	0.2	0.14	0.25		0.35		
Wear Factor (K) (in- min/fl-lbs-hr)	216	22	65	216		72		
Limiting PV (psi/fpm)	2,700	12,000	11,500	2,700		2,750		
Abrasion Resistance Index	137			137			116	
Coefficient of Linear Thermal Expansion (in/in/F) ($\times 10^{-5}$)	5.0	6.8	5.0	5.0		4.0	3.1	
Continuous Service Temp. - in Air (max.) (F)	180	180	180	180		212	338	338
Deflection Temp. (264 PSI) (F)	260	255	244	260		194	392	408
Melting Point (F)	347	347	347	347		491	660	680
Deformation Under Load (2000 PSI, 122° F.) (%)	0.6	0.7	0.6	0.6		2		
Dielectric Strength (Volts/mil)	380	400	400	380		400		670
Volume Resistivity (Ohm-CM) ($\times 10^{15}$)	0.1	5	30	0.1		0.045	670	70
Dielectric Constant (1 kHz)		3.5	3.1	3.7		4	3.15	

TABLE 2-continued

Property	Properties of Acetyl Materials							
	Acetyl Material							
	Acetyl and Celcon ®	Acetyl, Chem. Lub.	Acetyl, Teflon filled/ Delrin ® AF	Delrin ®	Vespel ® SP-1	Ensilon ®	Ultem ® 1000	Ultem ® 2200
Dielectric Constant (1 MHz)		3.5	3.1	3.7		3.4		
Dielectric Constant (60 Hz)		3.5		3.7		4.1	3.2	

[0041] Another desirable characteristic for the material selected for the control valve and/or wear plate is that the material does not swell when it contacts the liquid to be pumped. In the applications discussed above, it is preferable that the materials do not swell when in contact with water, alcohols and/or short-chain hydrocarbons. By "not swell," it is meant that the materials do not expand more than 1% of their original size and preferably expand less than 0.5% or not at all. As a related characteristic, the selected material preferably is chemically inert relative to the liquid to be pumped, meaning that the material is suitable for exposure to the liquid for prolonged periods of time without adversely affecting the purity of the liquid or the operation of the pump.

[0042] As a schematic, graphical representation of the above, FIG. 5 demonstrates a valve assembly 500 that includes a wear plate 502 and a control valve 504 that are formed from dissimilar materials 506 and 508. As illustrative, non-exclusive examples, material 506 may be alumina or Nitronic® and material 508 may be any of the polymers described above. As another example, material 506 may be formed from a first one of alumina or Nitronic® and material 508 may be formed from the other of alumina or Nitronic®. As a variation of the above, other stainless steels or similar metals may be substituted for Nitronic®.

[0043] In FIG. 5, the control valve and wear plate have been schematically illustrated. For example, for the purpose of simplifying the drawing, the grooves in the control valve and the liquid passages have not been included. Similarly, the control valve and wear plate have been shown without requiring a particular mounting structure or configuration for coupling these components to the corresponding structures of the pumps in which they are used. It is within the scope of the disclosure that the control valve and wear plate shown in FIG. 5, as well as in the subsequently discussed FIGS. 6-11, may have the configurations shown in FIGS. 1-4. Wear plates and control valves according to the present disclosure may also include variants of the control valves and wear plates shown in FIGS. 1-4, such as to define different groove complexes or geometries, to adapt the wear plate and/or control valve for different mounting configurations, to form wear plate 502 as an insert into a larger base, etc. As discussed above, the selection of materials discussed herein may also be applied to control valve/wear plate assemblies having other configurations and to other rotating or sliding pump components that are prone to stiction-based failures

when used to pump the carbon-containing feedstocks discussed herein. The same applies to the following examples of other configurations for control valves, wear plates, pistons, seals and the like.

[0044] In some applications, it may be desirable for a particular one of the control valve and wear plate to be formed from a particular first material and for the other one to be formed from a different material, while in other applications, either of the components may be formed from the selected materials. As an example, it may be desirable for the wear plate to be formed from the harder and/or the stronger of the two selected materials, with the control valve formed from the other of the selected materials. As a more particular example, harder materials such as alumina and Nitronic® stainless steels have proven effective for the wear plates when other materials, such as the polymers described above, are used for the control valves.

[0045] In some embodiments, it may be preferable for at least one of the selected materials to be self-lubricating. By this it is meant that the material itself has a low coefficient of friction and therefore does not require the introduction of a lubricant. For example, one or both of the materials may be selected to have a coefficient of (dynamic) friction that is less than 0.25, or even less than 0.2 or 0.1. Examples of self-lubricating materials include Teflon, Nitronic® stainless steels, and the acetyls discussed above. Examples of a valve assembly that includes a self-lubricating material 510 is shown in FIG. 6 and indicated generally at 500'. In solid lines, wear plate 502 is shown being formed from a self-lubricating material 510, and control valve 504 is formed from a compatible material 508, such as the illustrative materials described herein. In dashed lines in FIG. 6, control valve 504 is shown being formed from self-lubricating material 510 and wear plate 502 is formed from a compatible material 506, such as any of the illustrative materials described herein.

[0046] It is also within the scope of the disclosure that both wear plate 502 and control valve 504 may be formed from self-lubricating materials, and even the same self-lubricating material, so long as the above-discussed considerations are satisfied. This is graphically illustrated in FIG. 7, in which a valve assembly is shown at 500" that includes wear plate 502 and control valve 504 formed from different, and optionally dissimilar, self-lubricating materials 510 and 512, respectively. As discussed above, however, it is within the

scope of the disclosure that the same self-lubricating material may be used for both the control valve and the wear plate, as indicated in dashed lines at **510'**.

[0047] It should be understood from the above discussion that the control valve and wear plate for a particular pump have respective bearing, or engagement, surfaces that engage and rotate relative to each other during use. Furthermore, the control valve and wear plate also include other regions that are not in direct shearing (or potentially shearing) or other contact with each other. Therefore, it is within the scope of the disclosure that either or both of the components may include a contact surface, or contact region, that is formed from a first material, such as those discussed above, with the body, core or other portion of the component being formed from a different material, such as another of the materials discussed above. Similarly, materials that may not be effective for contact surfaces may still be effective, or even beneficial, when used for a core, body, or other portion of the control valve or contact surface. As an illustrative example, alumina is several times more expensive than most, if not all, of the materials discussed above. Therefore, in embodiments where it is desirable for alumina to form the contact surface of one of the components, such as the wear plate, the entire wear plate does not have to be formed from alumina. Instead, the wear plate may include a body or core that is formed from another suitable (i.e. chemically acceptable and of sufficient structural strength and durability) material that is less expensive than alumina. As another example, wear plate **502** may include a base that is not formed from alumina and which provides a mounting structure that is more readily, or easily, secured or otherwise secured to the rest of the pump than alumina.

[0048] Illustrative, graphical examples of the above constructions are shown in **FIGS. 8-11**. In **FIG. 8**, a wear plate **502** is shown with a body **520** that is formed from a first material **522**, which may be any suitable material having the strength characteristics described above. As shown, body **520** includes a contact surface **524** that is adapted to engage a corresponding contact surface of a control valve. As also shown in **FIG. 8**, contact surface **524** includes a coating **526** of a material **528**, such as one of above-described materials, that is adapted to inhibit stiction with the material used for a corresponding control valve, especially when the pump is used to pump liquid streams that contain at least a modest carbon-containing feedstock component. Although any of the suitable materials described herein may be used for material **522**, it may also be formed from a material that otherwise would be prone to causing stiction-based or other failures of the pump because coating **526** prevents contact between material **522** and control valve **504**. In the illustrated example, coating **526** extends across only contact surface **524** of the wear plate, as the other surfaces of the wear plate are not contacted by the control valve and therefore do not affect the valve assembly's likelihood to seize when used to pump a liquid containing a carbon-containing feedstock, such as methanol or another alcohol. It is within the scope of the disclosure, however, that up to the entire exterior surface **524** of the wear plate may be coated with material **528**, as schematically illustrated in dashed lines.

[0049] A similar construction may be used for control valve **504**, as shown in **FIG. 9**. As shown, control valve **504** includes a body **530** that is formed from a first material, such

as a material **532** that has the strength characteristics described above. As shown, body **530** includes a contact surface **534** that is adapted to rotationally engage the corresponding contact surface of a wear plate. As shown, contact surface **534** includes a coating **536** of a material, **538**, such as one of the above-described materials that is suitable for forming the entire control valve. As discussed above in the context of the coated wear plate, it is within the scope of the disclosure that coating **536** may extend over more of the exterior surface of the control valve than contact surface **534**, including extending over the entire exterior surface of the control valve, as schematically illustrated in dashed lines.

[0050] As another example, **FIG. 10** demonstrates a wear plate **502** that includes a body with a core **540** formed from a first material, such as material **522**, and a structural control-valve contacting region, or layer, **542**, which is formed from material **506**. As opposed to a coating that relies upon the underlying body to provide the structural integrity of the wear plate, layer **542** is itself a structural layer that is mounted on core **540** and includes a contact surface **544** that is adapted to contact the corresponding contact surface of the control valve. This illustrative construction may also be implemented with control valve **504**, as shown in **FIG. 11**. As shown, the control valve includes a core **550**, which is formed from a first material, such as material **532**, and a structural wear-plate contacting region, or layer, **552**, which is formed from material **508**. As shown, layer **552** includes a contact surface **554** that is adapted to rotationally engage a corresponding contact surface of a wear plate.

[0051] It is within the scope of the disclosure that coated or plural-layered components shown in **FIGS. 8-11** may be used with each other or with corresponding components that are entirely formed from a selected material, such as the components previously illustrated in **FIGS. 5-7**. It is also within the scope of the disclosure that the control valves and wear plates described, incorporated and/or illustrated herein may be used with other piston and/or pump configurations, such as pumps with only a single piston, pumps with more than a pair of reciprocating pistons, and pumps that are not configured to provide pulseless flows of liquid.

[0052] In **FIGS. 1 and 3**, it can be seen that both embodiments of the illustrated pumps include seals to provide liquid seals around the pistons and thereby prevent leakage of the liquid to be pumped through these seals. However, it has been discovered that the seals are not effective at preventing leaks when the above-described fluids that include carbon-containing feedstock components are used. In **FIG. 1**, the seals take the form of O-rings that extend around the shafts of the pistons. In **FIG. 3**, the seals take the form of hollow plastic members that have an outer perimeter that seats within a bore in the housing **401** of the pump and an inner edge that is biased against the shaft of the corresponding piston. In experiments, neither seal has proven effective at preventing leaks when the pumps are used to pump liquids containing at least a modest carbon-containing feedstock component. For example, the seals shown in **FIG. 3** have demonstrated a tendency to take a compression set over time and thereafter not form a liquid-tight seal with the piston.

[0053] An improved seal for use around the seals of reciprocating pistons, such as in pumps having a construc-

tion as shown in the Beckett patents or other piston-based pumps, is shown in **FIG. 12** and generally indicated at **600**. As shown, the seal is received within a bore **602** in a housing, or body, **604** that defines at least a portion of passage **606** within which a piston **608** reciprocates. Seal **600** is annular in construction and includes a body **610** that includes a base **612** that is seated within the bore, and a pair of projecting arms **614** and **616** that define respective inner and outer perimeters of a channel **618** into which a resilient O-ring or similar member **620** is inserted. As shown, arm **614** seals against the sidewall **622** of bore **602** and further seals against surface **624**, which may correspond to a portion of wear plate **502**, a mount for the piston, or another internal portion of the pump's housing. In the illustrated embodiment, arm **614** is maintained in a biased, or flexed, configuration at least partially on account of its engagement with surface **624**, and this flexing, or biasing of the arm urges a tighter seal against sidewall **622**. Arm **616** is biased against piston **608**, with member **620** further biasing and establishing a restoring force that urges the arm into sealing engagement with the piston. Illustrative relative dimensions for seal **600** relative to piston **608** have been shown in **FIG. 12**, but it is within the scope of the present disclosure that other relative and scaled dimensions may be used.

[0054] Preferably, body **610** is formed from a long-wearing plastic material, such as UHMW-PE. In the illustrative embodiment shown in **FIG. 12**, it can also be seen that seal **600** is substantially larger than the previously illustrated seals. Therefore, in a retrofit application, enlargement of the bores into which the seals are housed is required. It is within the scope of the disclosure, however, that the seals may be reduced in size and/or that the housing may be originally formed to accept seal **600**. In **FIG. 13**, seals **600** are shown schematically implemented with the previously described pump of **FIG. 1**. In **FIG. 14**, seals **600** are shown schematically implemented with the previously described pump of **FIG. 3**. For ease in correlating **FIGS. 13 and 14** with the previously presented **FIGS. 1 and 3**, the reference numerals from **FIGS. 1 and 3** and also shown in **FIGS. 13 and 14**, as well as in the subsequently described **FIGS. 15-17**. The modified pumps are generally indicated in **FIGS. 13-17** at **10'** or **400'**. It is within the scope of the present disclosure that either of these illustrative embodiments may, but is not required to, further include valve assemblies constructed according to the present disclosure, such as shown in **FIGS. 5-11**.

[0055] Pumps according to the present disclosure also preferably (but are not required to) include pistons that are formed from a non-abrasive material so that the reciprocating motion of the pistons does not abrade the sealing surfaces of the seals, thereby resulting in leaks over time. Examples of non-abrasive materials include, but are not limited to, the metal and/or polymer materials described herein. Similar to the above discussion regarding the control valves and wear plates, it is within the scope of the disclosure to utilize self-lubricating materials for the pistons. The pistons may also have coated and/or layered constructions that produce a non-abrasive outer surface even if the pistons include a core or base that is formed from an abrasive material.

[0056] Experiments have also shown that the pistons shown in **FIGS. 1 and 3** may not follow identical reciprocating paths on account of insufficient support or alignment

structure in the pump. Therefore, another aspect of the present disclosure is to include a supporting collar that extends around the pistons and aligns the pistons relative to their corresponding passages. This aspect may be used with or independent of either or both of the previously described aspects. Examples of pumps having pistons supported by aligning collars **700** are shown in **FIGS. 15-17**. In **FIG. 15**, the pump of **FIG. 1** is shown with a single piston-aligning collar **700** extending around each piston, while **FIG. 16** demonstrates an embodiment of the pump of **FIG. 1** with a pair of collars extending in a spaced-apart relationship around each piston. In **FIG. 17**, the pump of **FIG. 3** is shown with a piston-aligning collar extending around each piston. As shown, the collars are received within bores in the housing of the pumps and extend around the pistons. Collars **700** are preferably formed from a self-lubricating, long-wearing material, such as those described above. Examples of suitable materials include Iglide® T500 and variants thereof that are available from Igus, Delrin® and various polyimides.

[0057] In applications where pumps according to the present disclosure are used to deliver a liquid that contains a feed stream for a fuel processor, an illustrative flow rate is a selected flow rate within the range of 0-100 mL/min. By this it is meant that the pumps are adapted to provide a flow rate of up to 100 mL/min, but the flow rate may be selectively controlled to be less than this amount. It is also within the scope of the disclosure that the pumps may be adapted to provide flow rates that exceed 100 mL/min. Continuing the above example for fuel processing applications, the pumps will typically operate with a pressure differential of less than 250 psi, and often of approximately 150-225 psi, such as 200 psi. Preferably, the pumps are adapted to operate for useful lives of at least 35,000 hours at 200 psi, and more preferably at least 50,000 hours at this exemplary pressure.

[0058] An illustrative, schematic depiction of a fuel cell system that includes a feedstock delivery system with at least one pump according to the present disclosure is shown in **FIG. 18** and generally indicated at **810**. System **810** includes at least one fuel processor **812** and at least one fuel cell stack **822**. Fuel processor **812** is adapted to produce a product hydrogen stream **814** containing hydrogen gas from a feed stream **16** containing at least one feedstock. The fuel cell stack is adapted to produce an electric current from the portion of product hydrogen stream **814** delivered thereto. In the illustrated embodiment, a single fuel processor **812** and a single fuel cell stack **822** are shown; however, it is within the scope of the disclosure that more than one of either or both of these components may be used. It should be understood that these components have been schematically illustrated and that the fuel cell system may include additional components that are not specifically illustrated in the figures, such as air delivery systems, heat exchangers, sensors, flow regulators, heating assemblies and the like. Similarly, the illustrative examples of fuel processors, fuel processing systems and fuel cell systems illustrated and, described with respect to **FIG. 18** and subsequently presented **FIGS. 19-21** are presented for purposes of illustration. Pumps according to the present disclosure may be used with other fuel processing or fuel cell systems, as well as other applications in which a stream that contains a carbon-containing feedstock, water, and/or other liquids needs to be pumped.

[0059] Fuel processor **812** is any suitable device or assembly that produces from feed stream **816** a stream, such as product hydrogen stream **814**, that is at least substantially comprises of hydrogen gas. Examples of suitable mechanisms for producing hydrogen gas from feed stream **816** include steam reforming and autothermal reforming, in which reforming catalysts are used to produce hydrogen gas from a feed stream containing a carbon-containing feedstock and water. Other suitable mechanisms for producing hydrogen gas include pyrolysis and catalytic partial oxidation of a carbon-containing feedstock, in which case the feed stream does not contain water. Illustrative examples of suitable carbon-containing feedstocks include at least one hydrocarbon or alcohol. Illustrative examples of suitable hydrocarbons include methane, propane, natural gas, diesel, kerosene, gasoline and the like. Examples of suitable alcohols include methanol, ethanol, and polyols, such as ethylene glycol and propylene glycol.

[0060] Feed stream **816** may be delivered to fuel processor **812** via any suitable mechanism. Although only a single feed stream **816** is shown in **FIG. 18**, it is within the scope of the present disclosure that more than one stream **816** may be used and that these streams may contain the same or different feedstocks. When carbon-containing feedstock **818** is miscible with water, the feedstock is typically, but not required to be, delivered with the water component of feed stream **816**, such as shown in **FIG. 18**. When the carbon-containing feedstock is immiscible or only slightly miscible with water, these feedstocks are typically delivered to fuel processor **812** in separate streams, such as shown in **FIG. 19**. In **FIGS. 18 and 19**, feed stream **816** is shown being delivered to fuel processor **812** by a feedstock delivery system **817**, which includes at least one pump **819** according to the present disclosure. Pump **819** may be one of the pumps **10'** or **400'** illustrated herein, but it is also within the scope of the disclosure that it is a reciprocating pump that includes one or more of the stiction-inhibiting structures, compositions and/or collars disclosed herein.

[0061] Fuel cell stack **822** contains at least one, and typically multiple, fuel cells **824** that are adapted to produce an electric current from the portion of the product hydrogen stream **814** delivered thereto. This electric current may be used to satisfy the energy demands, or applied load, of an associated energy-consuming device **825** that is adapted to apply a load on, or to, the fuel cell system. Illustrative examples of devices **825** include, but should not be limited to, any combination of one or more motor vehicles, recreational vehicles, boats and other seacraft, and any combination of one or more residences, commercial offices or buildings, neighborhoods, tools, lights and lighting assemblies, appliances, computers, industrial equipment, signaling and communications equipment, batteries and even the balance-of-plant electrical requirements for the fuel processing or cell system of which stack **824** forms a part. Device **825** is schematically illustrated in **FIG. 18** and is meant to represent one or more devices or collection of devices that are adapted to draw electric current from the fuel cell system.

[0062] A fuel cell stack typically includes multiple fuel cells joined together between common end plates **823**, which contain fluid delivery/removal conduits. Illustrative examples of suitable types of fuel cells include phosphoric-acid fuel cells (PAFC), molten-carbonate fuel cells (MCFC),

solid-oxide fuel cells (SOFC), alkaline fuel cells (AFC), and proton-exchange-membrane fuel cells (PEMFC, or PEM fuel cells). Occasionally PEM fuel cells are referred to as solid-polymer fuel cell (SPFC) because the membrane that separates the anode from the cathode is a polymer film that readily conducts protons, but is an electrical insulator. Fuel cell stack **822** may receive all of product hydrogen stream **814**. Some or all of stream **814** may additionally, or alternatively, be delivered, via a suitable conduit, for use in another hydrogen-consuming process, burned for fuel or heat, or stored for later use. For example, system **810** may include at least one hydrogen storage device **813**, as schematically illustrated in dashed lines in **FIG. 18**. Examples of suitable hydrogen storage devices include pressurized tanks and hydride beds. Similarly, system **810** may include at least one energy-storage device **815**, as also indicated in dashed lines in **FIG. 18**. Examples of suitable energy-storage devices include batteries, ultra capacitors, and flywheels.

[0063] In many applications, it is desirable for the fuel processor to produce at least substantially pure hydrogen gas. Accordingly, the fuel processor may utilize a process that inherently produces sufficiently pure hydrogen gas, or the fuel processor may include suitable purification and/or separation devices or assemblies that remove impurities from the hydrogen gas produced in the fuel processor. As another example, the fuel processing system or fuel cell system may include purification and/or separation devices downstream from the fuel processor. In the context of a fuel cell system, the fuel processor preferably is adapted to produce substantially pure hydrogen gas, and even more preferably, the fuel processor is adapted to produce pure hydrogen gas. For the purposes of the present disclosure, substantially pure hydrogen gas is greater than 90% pure, preferably greater than 95% pure, more preferably greater than 99% pure, and even more preferably greater than 99.5% pure. Illustrative examples of suitable fuel processors are disclosed in U.S. Pat. Nos. 6,221,117, 5,997,594, 5,861,137, and pending U.S. patent application Ser. Nos. 09/802,361 and 10/407,500.

[0064] For purposes of illustration, the following discussion will describe fuel processor **812** as a steam reformer adapted to receive a feed stream **816** containing a carbon-containing feedstock **818** and water **820**. As discussed, stream **816** will typically include at least a modest amount of carbon-containing feedstock. However, it is within the scope of the disclosure that fuel processor **812** may take other forms, as discussed above. An illustrative example of a suitable steam reformer is schematically illustrated in **FIG. 20** and indicated generally at **830**. Reformer **830** includes a hydrogen-producing region **832** in which a mixed gas stream **836** containing hydrogen gas is produced from feed stream **816**. In the context of a steam reformer, the hydrogen-producing region may be referred to as a reforming region, the mixed gas stream may be referred to as a reformat stream, and the reforming region includes a steam reforming catalyst **834**. Alternatively, reformer **830** may be an autothermal reformer that includes an autothermal reforming catalyst.

[0065] When it is desirable to purify the hydrogen in the mixed gas, or reformat stream, stream **836** is delivered to a separation region, or purification region, **838**. In separation region **838**, the hydrogen-containing stream is separated into one or more byproduct streams, which are collectively

illustrated at **840** and which typically include at least a substantial portion of the other gases, and a hydrogen-rich stream **842**, which contains at least substantially pure hydrogen gas. The separation region may utilize any separation process, including a pressure-driven separation process. In **FIG. 20**, hydrogen-rich stream **842** is shown forming product hydrogen stream **814**.

[0066] An example of a suitable structure for use in separation region **838** is a membrane module **844**, which contains one or more hydrogen permeable metal membranes **846**. Examples of suitable membranes and membrane modules are disclosed in U.S. Pat. Nos. 6,319,306, 6,537,352, and 6,562,111. In the '306 patent, a plurality of generally planar membranes are assembled together into a membrane module having flow channels through which an impure gas stream is delivered to the membranes, a purified gas stream is harvested from the membranes and a byproduct stream is removed from the membranes. Gaskets, such as flexible graphite gaskets, are used to achieve seals around the feed and permeate flow channels. Also disclosed in the above-identified application are tubular hydrogen-selective membranes, which also may be used.

[0067] The thin, planar, hydrogen-permeable membranes are preferably composed of palladium alloys, most especially palladium with 35 wt % to 45 wt % copper, such as a palladium alloy containing approximately 40 wt % copper. These membranes, which also may be referred to as hydrogen-selective membranes, are typically formed from a thin foil that is approximately 0.001 inches thick, or less. It is within the scope of the present disclosure, however, that the membranes may be formed from hydrogen-selective metals and metal alloys other than those discussed above, hydrogen-permeable and selective ceramics, or carbon compositions. The membranes may have thicknesses that are larger or smaller than discussed above. For example, the membrane may be made thinner, with commensurate increase in hydrogen flux. The hydrogen-permeable membranes may be arranged in any suitable configuration, such as arranged in pairs around a common permeate channel as is disclosed in the above-identified patent applications. The hydrogen permeable membrane or membranes may take other configurations as well, such as tubular configurations, which are disclosed in the above-identified patents.

[0068] Another example of a suitable pressure-separation process for use in separation region **838** is pressure swing adsorption (PSA). A separation region containing a pressure swing adsorption assembly is schematically illustrated at **847** in dash-dot lines in **FIG. 20**. In a pressure swing adsorption (PSA) process, gaseous impurities are removed from a stream containing hydrogen gas. PSA is based on the principle that certain gases, under the proper conditions of temperature and pressure, will be adsorbed onto an adsorbent material more strongly than other gases. Typically, it is the impurities that are adsorbed and thus removed from reformat stream **836**.

[0069] The success of using PSA for hydrogen purification is due to the relatively strong adsorption of common impurity gases (such as CO, CO₂, hydrocarbons including CH₄, and N₂) on the adsorbent material. Hydrogen adsorbs only very weakly and so hydrogen passes through the adsorbent bed while the impurities are retained on the adsorbent material. The adsorbent bed periodically needs to be regen-

erated to remove these adsorbed impurities. Accordingly, pressure swing adsorption assemblies typically include a plurality of adsorbent beds so that at least one bed is configured to purify the mixed gas stream even if at least another one of the beds is not so-configured, such as if the bed is being regenerated, serviced, repaired, etc.

[0070] Impurity gases such as NH₃, H₂S, and H₂O adsorb very strongly on the adsorbent material and are therefore removed from stream **836** along with other impurities. If the adsorbent material is going to be regenerated and these impurities are present in stream **836**, separation region **838** preferably includes a suitable device that is adapted to remove these impurities prior to delivery of stream **836** to the adsorbent material because it is more difficult to desorb these impurities.

[0071] Adsorption of impurity gases occurs at elevated pressure. When the pressure is reduced, the impurities are desorbed from the adsorbent material, thus regenerating the adsorbent material. Typically, PSA is a cyclic process and requires at least two beds for continuous (as opposed to batch) operation. Examples of suitable adsorbent materials that may be used in adsorbent beds are activated carbon and zeolites, especially 5 Å (5 angstrom) zeolites. The adsorbent material is commonly in the form of pellets and it is placed in a cylindrical pressure vessel utilizing a conventional packed-bed configuration. It should be understood, however, that other suitable adsorbent material compositions, forms and configurations may be used.

[0072] From the preceding discussion, it should be apparent that byproduct stream **40** generally refers to the impurities that remain after hydrogen-rich stream is separated from the mixed gas stream. In some embodiments, this stream will be created as the hydrogen-rich stream is formed, such as in the context of membrane separation assemblies, while in other embodiments the stream is at least temporarily retained within the separation assembly, such as in the context of pressure swing adsorption assemblies.

[0073] As discussed, it is also within the scope of the disclosure that at least some of the purification of the hydrogen gas is performed intermediate the fuel processor and the fuel cell stack. Such a construction is schematically illustrated in dashed lines in **FIG. 20**, in which the separation region **838'** is depicted downstream from the shell **831** of the fuel processor. Therefore, it is within the scope of the present disclosure for the separation region to be at least partially, or even completely, contained within a common shell or otherwise integrated with the fuel processor, or for the separation region to be a separate, discrete structure that is in fluid communication with the fuel processor.

[0074] Reformer **830** (or other fuel processors **812**) may, but does not necessarily, additionally or alternatively, include a polishing region **848**, such as shown in **FIG. 21**. As shown, polishing region **848** receives hydrogen-rich stream **842** from separation region **838** and further purifies the stream by reducing the concentration of, or removing, selected compositions therein. Polishing region **848** may also be referred to as a chemical removal assembly, in that it refers to any suitable structure for reducing, via chemical reaction, the concentration of one or more selected components of the mixed gas or hydrogen-rich streams. For example, when stream **842** is intended for use in a fuel cell stack, such as stack **822**, compositions that may damage the

fuel cell stack, such as carbon monoxide and carbon dioxide, may be removed from the hydrogen-rich stream. For many conventional fuel cell stacks, the concentration of carbon monoxide should be less than 10 ppm (parts per million). Preferably, the system limits the concentration of carbon monoxide to less than 5 ppm, and even more preferably, to less than 1 ppm. The concentration of carbon dioxide may be greater than that of carbon monoxide. For example, concentrations of less than 25% carbon dioxide may be acceptable. Preferably, the concentration is less than 10%, and even more preferably, less than 1%. Especially preferred concentrations are less than 50 ppm. The acceptable maximum concentrations presented herein are illustrative examples, and that concentrations other than those presented herein may be used and are within the scope of the present disclosure. For example, particular users or manufacturers may require minimum or maximum concentration levels or ranges that are different than those identified herein. Similarly, when fuel processor **812** is not used with a fuel cell stack, or when it is used with a fuel cell stack that is more tolerant of these impurities, then the product hydrogen stream may contain larger amounts of these gases.

[0075] Region **848** includes any suitable structure for removing or reducing the concentration of the selected compositions in stream **842**. For example, when the product stream is intended for use in a PEM fuel cell stack or other device that will be damaged if the stream contains more than determined concentrations of carbon monoxide or carbon dioxide, it may be desirable to include at least one methanation catalyst bed **850**. Bed **850** converts carbon monoxide and carbon dioxide into methane and water, both of which will not damage a PEM fuel cell stack. Polishing region **848** also may (but is not required to) include another hydrogen-producing region **852**, such as another reforming catalyst bed, to convert any unreacted feedstock into hydrogen gas. In such an embodiment, it is preferable that the second reforming catalyst bed is upstream from the methanation catalyst bed so as not to reintroduce carbon dioxide or carbon monoxide downstream of the methanation catalyst bed. As another example, polishing, or chemical-removal, region **48** may be adapted to reduce the concentration of carbon monoxide through the water-gas shift reaction.

[0076] Steam reformers typically operate at temperatures in the range of 200° C. and 800° C., and at pressures in the range of 50 psi and 1000 psi, although temperatures and pressures outside of this range are within the scope of the disclosure, such as depending upon the particular type and configuration of fuel processor being used. Accordingly, steam reformers and other fuel processors that include a pump according to the present disclosure will typically include, or be in thermal communication with, a heating assembly **839**, which is shown in dashed lines in **FIG. 18**. Heating assembly **839** is schematically illustrated in **FIG. 18** to graphically depict that the heating assembly may be located within the fuel processor, external the fuel processor, or both. Heating assembly **839** may utilize any suitable heating mechanism or device to heat the fuel processor to a selected operating temperature. For example, heating assembly **839** may include a resistance heater, a burner or other combustion unit that produces a heated exhaust stream, heat exchange with a heated fluid stream, etc.

[0077] In **FIG. 18**, heating assembly **839** is shown including a fuel stream **841**, which will tend to vary in composition

and type depending upon the mechanism(s) used to produce heat. For example, when the heating assembly **839** is a burner or otherwise creates heat by combustion, stream **841** will include a stream of a combustible fuel, such as an alcohol or hydrocarbon, and/or a combustible gas, such as hydrogen gas. When heating assembly **839** includes an electric resistance heater, then stream **841** will include an electrical connection to an electrical power source. In some embodiments, feed stream **816** may be delivered to the fuel processor at an elevated temperature, and accordingly may provide at least a portion of the required heat. When a burner or other combustion chamber is used, a fuel stream is consumed and a heated exhaust stream is produced. Feed stream **816** is vaporized prior to undergoing the reforming reaction, and heating assembly **839** may be adapted to heat and vaporize any liquid components of feed stream **816**. This is schematically illustrated in dashed lines in **FIG. 18** at **843**.

[0078] In **FIGS. 20 and 21**, reformer **830** is shown including a shell **831** in which the above-described components are contained. Shell **831**, which also may be referred to as a housing, enables the fuel processor, such as reformer **830**, to be moved as a unit. It also protects the components of the fuel processor from damage by providing a protective enclosure and reduces the heating demand of the fuel processor because the components of the fuel processor may be heated as a unit. Shell **831** may, but does not necessarily, include insulating material **833**, such as a solid insulating material, blanket insulating material, or an air-filled cavity. The shell may include one or more constituent sections. When reformer **830** includes insulating material **833**, the insulating material may be internal the shell, external the shell, or both. When the insulating material is external a shell containing the above-described reforming, separation and/or polishing regions, the fuel processor may further include an outer cover or jacket external the insulation. It is within also the scope of the disclosure, however, that the reformers or other fuel processors that include one or more pumps according to the present disclosure may be formed without a housing or shell.

[0079] It is further within the scope of the disclosure that one or more of the components may either extend beyond the shell or be located external at least shell **831**. For example, and as schematically illustrated in **FIG. 21**, polishing region **848** may be external shell **831** and/or a portion of reforming region **832** may extend beyond the shell. Other examples of fuel processors demonstrating these configurations are illustrated in the above-identified references and discussed in more detail herein.

[0080] Although fuel processor **812**, feedstock delivery system **817**, fuel cell stack **822** and energy-consuming device **825** may all be formed from one or more discrete components, it is also within the scope of the disclosure that two or more of these devices may be integrated, combined or otherwise assembled within an external housing or body. For example, a fuel processor and feedstock delivery system may be combined to provide a hydrogen-producing device with an on-board, or integrated, feedstock delivery system, such as schematically illustrated at **826** in **FIG. 18**. Similarly, a fuel cell stack may be added to provide an energy-generating device with an integrated feedstock delivery system, such as schematically illustrated at **827** in **FIG. 18**.

[0081] Fuel cell system **810** may additionally be combined with an energy-consuming device, such as device **825**, to provide the device with an integrated, or on-board, energy source. For example, the body of such a device is schematically illustrated in **FIG. 18** at **828**. Examples of such devices include a motor vehicle, such as a recreational vehicle, automobile, industrial vehicle, boat or other seacraft, and the like, or self-contained equipment, such as an appliance, light, tool, microwave relay station, transmitting assembly, remote signaling or communication equipment, measuring or detection equipment, etc.

[0082] It is within the scope of the disclosure that the feedstock delivery system and fuel processor **812**, such as reformer **830**, may be used independent of a fuel cell stack. In such an embodiment, the system may be referred to as a fuel processing system, and it may be used to provide a supply of pure or substantially pure hydrogen to a hydrogen-consuming device, such as a burner for heating, cooking or other applications. Similar to the above discussion about integrating the fuel cell system with an energy-consuming device, the fuel processor and hydrogen-consuming device may be combined, or integrated.

Industrial Applicability

[0083] The disclosed pumps are applicable to the fuel processing and other industries in which there is a need to pump streams that contain at least a modest amount of carbon-containing feedstock.

[0084] It is believed that the disclosure set forth above encompasses multiple distinct inventions with independent utility. While each of these inventions has been disclosed in its preferred form, the specific embodiments thereof as disclosed and illustrated herein are not to be considered in a limiting sense as numerous variations are possible. The subject matter of the inventions includes all novel and non-obvious combinations and subcombinations of the various elements, features, functions and/or properties disclosed herein. Similarly, where the claims recite "a" or "a first" element or the equivalent thereof, such claims should be understood to include incorporation of one or more such elements, neither requiring nor excluding two or more such elements.

[0085] It is believed that the following claims particularly point out certain combinations and subcombinations that are directed to one of the disclosed inventions and are novel and non-obvious. Inventions embodied in other combinations and subcombinations of features, functions, elements and/or properties may be claimed through amendment of the present claims or presentation of new claims in this or a related application. Such amended or new claims, whether they are directed to a different invention or directed to the same invention, whether different, broader, narrower or equal in scope to the original claims, are also regarded as included within the subject matter of the inventions of the present disclosure.

What is claimed is:

1. In a pump having a housing with at least first and second rotary control valve that comprises (1) a rotary control member having a rotatable control surface having first and second flow channels inscribed in the control surface, without extending through the control member, with the first of the flow control channels including an arcuate

control portion that communicates with a circular channel portion of greater diameter and a second of the flow control channels including an arcuate control portion of a same radius as the arcuate control portion of the first flow control channel, and with the arcuate control portion of the second flow control channel communicating with a circular channel of a smaller diameter than the arcuate control portion of the second flow control channel; (2) a plurality of reciprocating pistons; and (3) a stationary control plate that fits against the control surface to form closed passageways between the control plate and the first and second flow control channels in the control surface, with the control plate including a first primary opening through the control plate positioned to communicate with the circular portion of the first channel, a second primary opening through the control plate positioned to communicate with the circular portion of the second flow control channel, and a first secondary opening and a second secondary opening through the control plate, each separately positioned to communicate with the arcuate portions of both the first and second flow control channels, and further with the first and second secondary openings being in constant communication with respective first and second reciprocating pistons, such that each of the first and second primary openings is successively brought into fluid communication with the first and second secondary openings during different portions of the control surface rotation, whereby fluid communication is successively established between each of the reciprocating pistons and the primary inlet opening as the control surface rotates, and fluid communication is successively established between each of the reciprocating pistons and the primary outlet opening as the control surface rotates, the improvement comprising: at least one of the control surface and the control plate being formed from a self-lubricating material that has a coefficient of friction that is less than 0.25.

2. The pump of claim 1, wherein at least one of the control surface and the control plate is formed from a material that has a coefficient of friction that is less than 0.2.

3. The pump of claim 1, wherein at least one of the control surface and the control plate is formed from a material that has a coefficient of friction that is less than 0.1.

4. The pump of claim 1, wherein both the control valve and the control plate are formed from a self-lubricating material that has a coefficient of friction that is less than 0.25.

5. The pump of claim 1, wherein the control surface and the control plate are formed from dissimilar materials, with one of the control surface and the control plate comprising a metal, a polymer and a ceramic, and the other of the control surface and the control plate comprising a different one of the a metal, a polymer and a ceramic.

6. The pump of claim 5, wherein at least one of the control surface and the control plate is formed from a metal comprising at least one of stainless steel and titanium.

7. The pump of claim 5, wherein at least one of the control surface and the control plate is formed from a polymer comprising at least one of an acetal and a polyimide.

8. The pump of claim 5, wherein at least one of the control surface and the control plate is formed from a ceramic material.

9. The pump of claim 1, wherein at least one of the control surface and the control plate are formed from a material that will not expand more than 1% when exposed to a stream that includes at least 30 wt % of a carbon-containing feedstock.

10. The pump of claim 9, wherein both the control surface and the control plate are formed from a material that will not expand more than 1% when exposed to a stream that includes at least 30 wt % of a carbon-containing feedstock.

11. The pump of claim 9, wherein at least one of the control surface and the control plate are formed from a material that will not expand more than 0.5% when exposed to a stream that includes at least 30 wt % of a carbon-containing feedstock.

12. The pump of claim 9, wherein at least one of the control surface and the control plate are formed from a material that will not expand when exposed to a stream that includes at least 30 wt % of a carbon-containing feedstock.

13. The pump of claim 1, wherein the control plate is formed from a harder material than the control surface.

14. The pump of claim 1, wherein the improvement further comprises at least one aligning collar extending around each of the plurality of pistons and adapted to align the piston within the corresponding passageway, wherein each collar is mounted within the pump and includes at least a piston-contacting surface that is formed from a self-lubricating material.

15. The pump of claim 14, wherein each collar is formed from a material that will not expand more than 1% when exposed to a stream containing at least 30 wt % of a carbon-containing feedstock.

16. The pump of claim 1, wherein the improvement further comprises at least one seal extending around each of the plurality of pistons, wherein the seal comprises a body with a base that extends around the piston and a pair of spaced-apart arms that define a channel extending therebetween, with the arms and the channel each extending around the piston, and further wherein the seal comprises a resilient annular member seated within the channel and adapted to bias the arms generally away from each other, with one of the arms being biased against the piston.

17. A fuel processing system, comprising:

a hydrogen-producing region adapted to produce a mixed gas stream containing hydrogen gas and other gases from a feed stream comprising at least 30 wt % of a carbon-containing feedstock; and

a feedstock delivery system adapted to deliver the feed stream to the hydrogen-producing region, wherein the feedstock delivery system includes at least one pump, the pump comprising:

a housing defining a plurality of passages;

a plurality of reciprocating pistons adapted to be reciprocatingly driven within the plurality of passages;

a rotary control valve comprising a rotary control member having a rotatable control surface having at least first and second flow channels inscribed in the control surface, without extending through the control member, wherein the first of the flow control channels includes an arcuate control portion that communicates with an arcuate channel portion of greater diameter and a second of the flow control channels includes an arcuate control portion that corresponds to the the arcuate control portion of the first flow control channel, and with the arcuate control portion of the second flow control channel communicating with a second arcuate channel having different dimensions that the arcuate control portion of the second flow control channel;

a stationary control plate that fits against the control surface to form closed passageways between the control plate and the first and second flow control channels in the control surface, with the control plate including a first primary opening through the control plate positioned to communicate with the arcuate portion of the first channel, a second primary opening through the control plate positioned to communicate with the arcuate portion of the second flow control channel, and a first secondary opening and a second secondary opening through the control plate, each separately positioned to communicate with the arcuate portions of both the first and second flow control channels, and further with the first and second secondary openings being in constant communication with respective first and second reciprocating pistons, such that each of the first and second primary openings is successively brought into fluid communication with the first and second secondary openings during different portions of the control surface rotation, whereby fluid communication is successively established between each of the reciprocating pistons and the primary inlet opening as the control surface rotates, and fluid communication is successively established between each of the reciprocating pistons and the primary outlet opening as the control surface rotates;

a plurality of collars mounted in the housing, formed from a different material than the housing, and adapted to align at least the first and the second reciprocating pistons within the corresponding plurality of passages; and

a plurality of seals positioned in the housing and adapted to extend around at least the first and the second reciprocating pistons, wherein each of the seals comprises a body with a base that extends around the piston and a pair of spaced-apart arms that define a channel extending therebetween, with the arms and the channel each extending around the piston, and further wherein the seal comprises a resilient annular member seated within the channel and adapted to bias the arms generally away from each other, with one of the arms being biased against the corresponding piston.

18. The fuel processing system of claim 17, wherein at least one of the control surface and the control plate is formed from a self-lubricating material that has a coefficient of friction that is less than 0.25.

19. The fuel processing system of claim 17, wherein at least one of the control surface and the control plate are formed from a polymeric material that comprises at least one polyimide, acetyl or combinations thereof.

20. The fuel processing system of claim 17, wherein at least one of the control surface and the control plate is formed from titanium, stainless steel, or combinations thereof.

21. The fuel processing system of claim 17, wherein the feed stream further comprises water.

22. The fuel processing system of claim 17, wherein the carbon-containing feedstock includes at least one hydrocarbon, alcohol or mixtures thereof.