



US 20050014056A1

(19) **United States**

(12) **Patent Application Publication**
Zuber et al.

(10) **Pub. No.: US 2005/0014056 A1**

(43) **Pub. Date: Jan. 20, 2005**

(54) **MEMBRANE ELECTRODE UNIT FOR ELECTROCHEMICAL EQUIPMENT**

(52) **U.S. Cl.** **429/34; 429/38; 429/33; 429/35; 29/730; 29/623.2; 29/623; 29/623.5; 429/32**

(75) **Inventors: Ralf Zuber, Grossostheim (DE); Klaus Schaack, Obernburg (DE); Sandra Wittpahl, Obertshausen (DE); Holger Dziallas, Freigericht-Neuses (DE); Peter Seipel, Alzenau (DE)**

(57) **ABSTRACT**

Correspondence Address:
KALOW & SPRINGUT LLP
488 MADISON AVENUE
19TH FLOOR
NEW YORK, NY 10022 (US)

The invention concerns a membrane electrode unit (MEU) for electrochemical equipment, especially for membrane fuel cells. The membrane electrode unit has a "semi-coextensive" design and contains an ionically conductive membrane, two catalyst layers, and gas distributor substrates of different sizes on the front and back sides. The first gas distributor substrate has smaller surface dimensions than the ionically conductive membrane, while the second gas distributor substrate has the same area as the ionically conductive membrane. The membrane electrode unit has, because of its special design, a stable structure that can be handled well, and which exhibits advantages for sealing the reactive gases off from each other and in its electrical properties. In particular, the hydrogen penetration current is distinctly reduced. The membrane electrode unit is used in PEM fuel cells, direct methanol fuel cells, electrolyzers, and other electrochemical equipment.

(73) **Assignee: UMICORE AG & Co. KG**

(21) **Appl. No.: 10/699,158**

(22) **Filed: Oct. 30, 2003**

(30) **Foreign Application Priority Data**

Jul. 14, 2003 (DE)..... 103 31 836.4

Publication Classification

(51) **Int. Cl.⁷** **H01M 2/00; H01M 2/02; H01M 2/08; H01M 2/14; H01M 8/10**

Figure 1

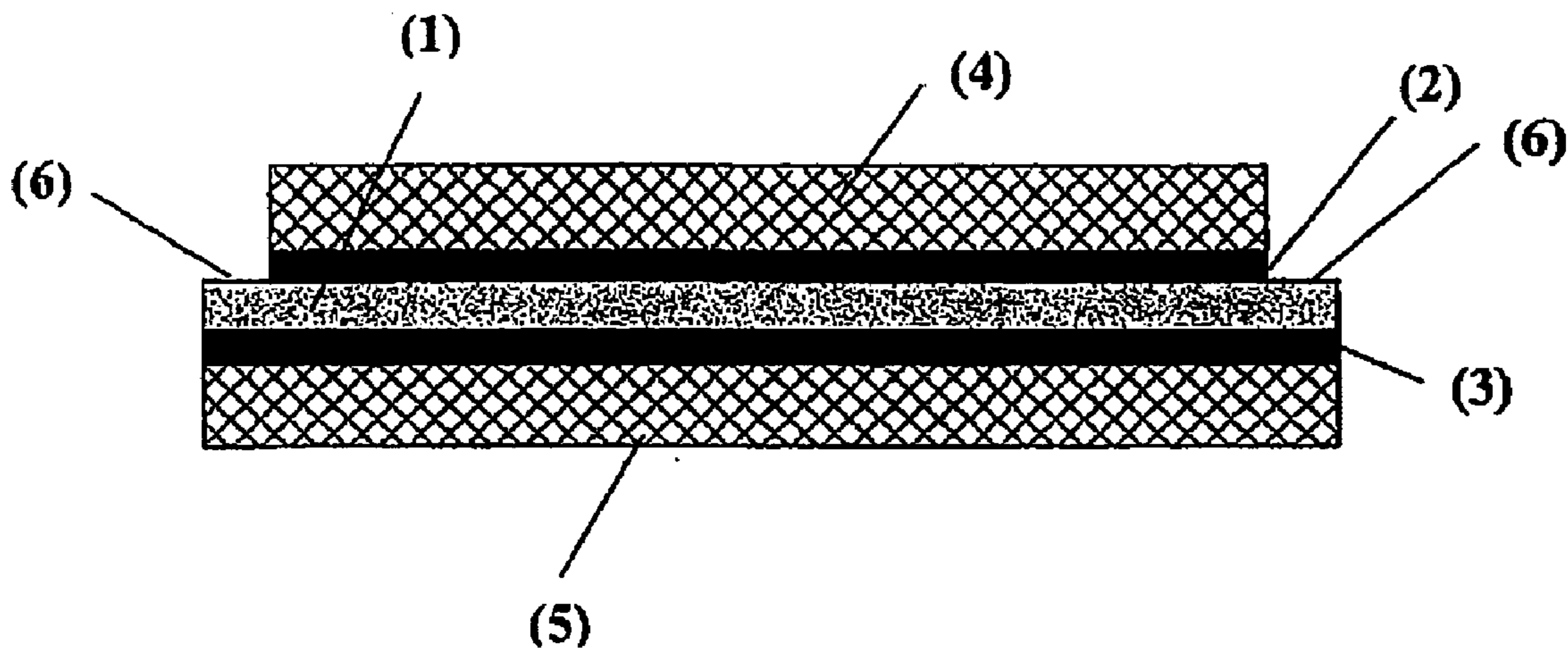

Figure 2

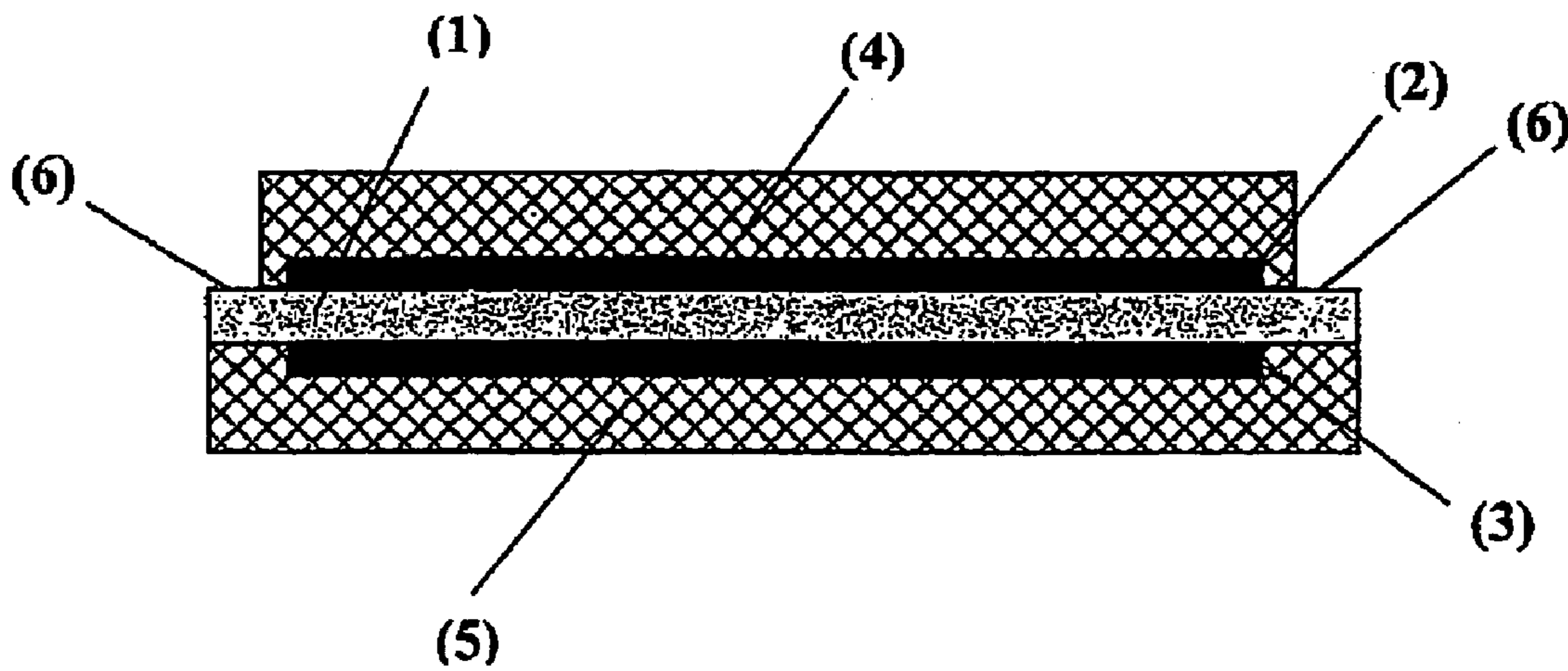

Figure 3

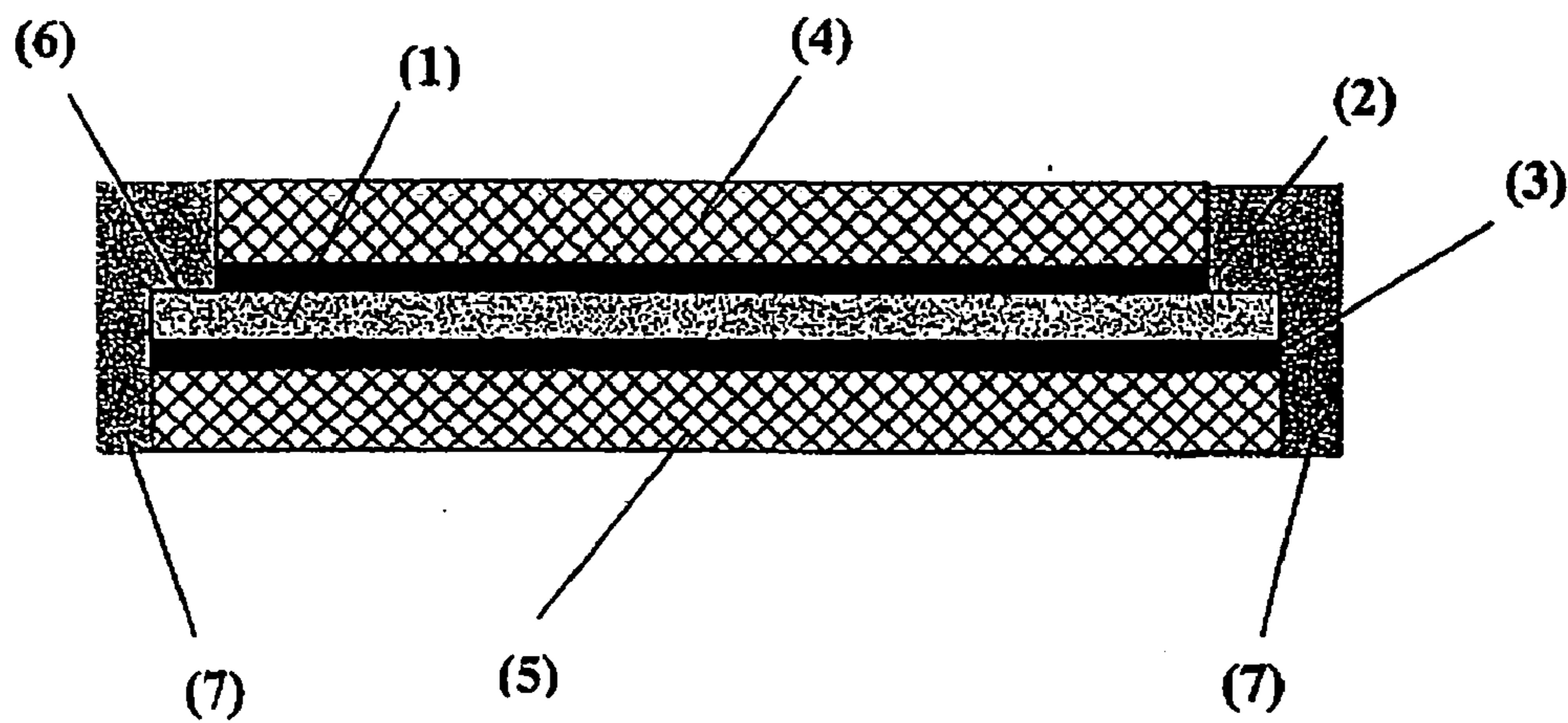
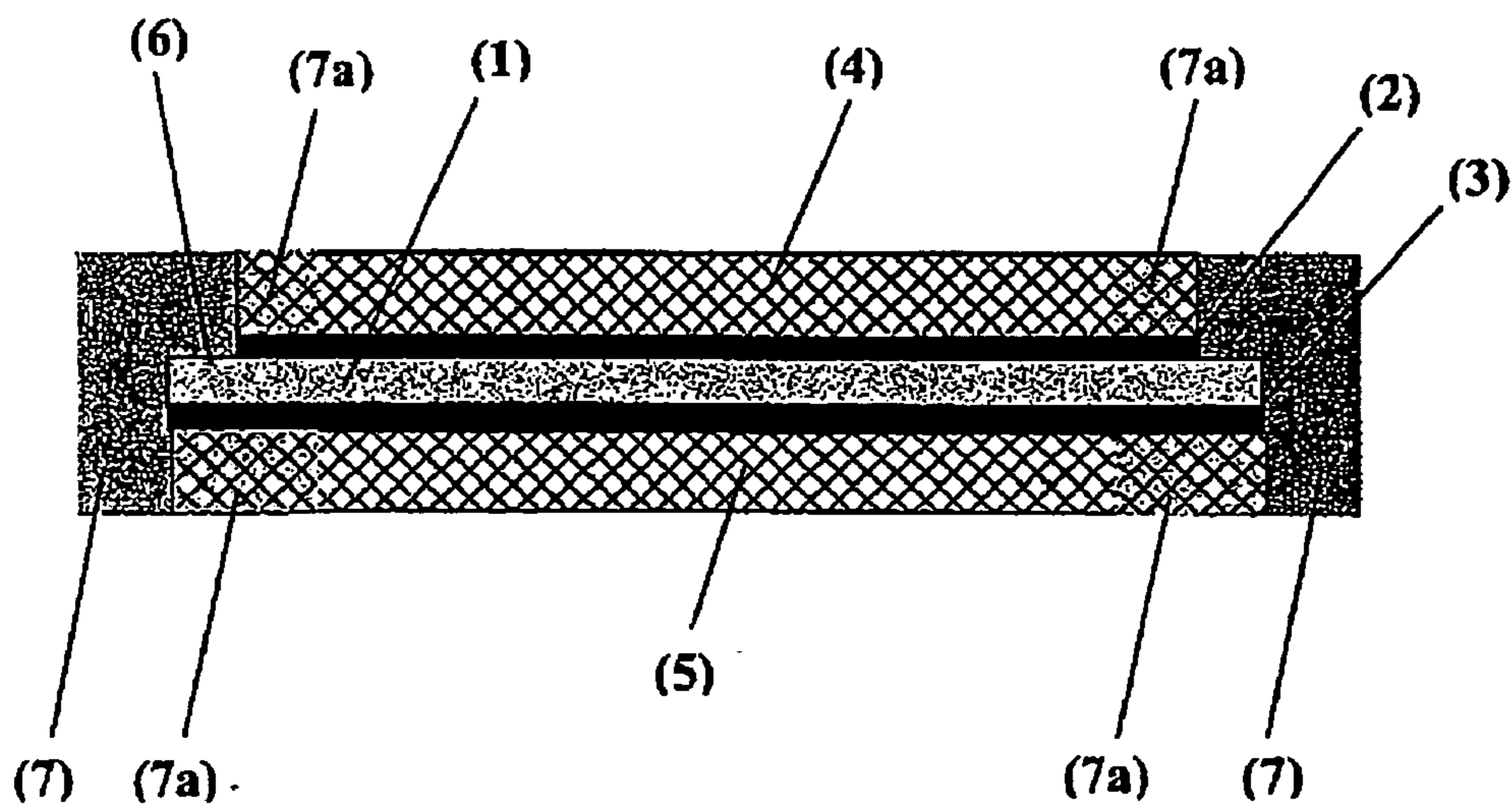

Figure 4



MEMBRANE ELECTRODE UNIT FOR ELECTROCHEMICAL EQUIPMENT

BACKGROUND OF THE INVENTION

[0001] The invention concerns the technological field of electrochemistry and describes a membrane electrode unit (“MEU”) for electrochemical equipment such as fuel cells (membrane fuel cells, PEMFC [polymer electrolyte membrane fuel cells], DMFC; etc.), electrolyzers, or electrochemical sensors. A process for producing the membrane electrode unit, and its use, are also described.

[0002] Fuel cells convert a fuel and an oxidizing agent, located apart from each other at two electrodes, into electrical current, heat and water. The fuel can be hydrogen or a hydrogen-rich gas. The oxidizing agent can be oxygen or air. The process of energy conversion in the fuel cell is distinguished by a particularly high efficiency. Because of that, fuel cells combined with electrical motors are gaining importance as alternatives for the usual combustion engines.

[0003] The polymer electrolyte fuel cell (PEM fuel cell) is particularly suitable for use in electric automobiles because of its compact construction, its power density, and its high efficiency.

[0004] In this invention, a PEM fuel cell stack is understood to be a stack-like arrangement (“stack”) of fuel cell units. In the following, a fuel cell unit is also called, briefly, a fuel cell. Each one contains a membrane electrode unit (MEU), which is placed between bipolar plates, also called separator plates, for gas supply and current conduction.

[0005] A membrane electrode unit comprises an ionically conductive membrane, which has electrodes, reaction layers containing catalysts, on both sides. One of the reaction layers is made as the anode for oxidation of hydrogen, and the second reaction layer is made as a cathode for reduction of oxygen. So-called gas distributor substrates (GDS) or gas-diffusion layers (GDL) of nonwoven carbon fiber, carbon fiber paper, or carbon fiber cloth are applied to these catalyst layers. They provide good access for the reaction gases to the electrodes, as well as good conduction of the cell current. The anode and cathode contain electrocatalysts that catalytically support the particular reaction (oxidation of hydrogen or reduction of oxygen).

[0006] The metals of the platinum group of the periodic system are preferably suited as catalytically active components. In most cases, supported catalysts, in which the catalytically active platinum group metals are applied in highly dispersed form to the surface of a conductive support material, are used. The mean crystallite size of the platinum group metals is then from about 1 to 10 nm. Finely divided conductive carbon blacks have proved good as support materials.

[0007] The ionically conductive membrane consists preferably of proton-conducting polymer materials. These materials are designated briefly as ionomers in the following. A tetrafluoroethylene-fluorovinyl ether copolymer with sulfonic acid groups is preferred. This material is sold, for example, by DuPont, under the tradename Nafion®. However, other ionomeric materials, especially fluorine-free ones, such as doped sulfonated polyether ketones or doped sulfonated or sulfinated arylketones, and doped polybenzimidazoles, are usable. Suitable ionically conductive mem-

branes have been described by O. Savadogo in “Journal of New Materials for Electrochemical Systems,” 1, 47-66 (1998). In general, these membranes must have a thickness from 10 to 200 μm for use in fuel cells.

[0008] The present invention describes membrane electrode units (MEUs) with improved characteristics with respect to power, lifetime, and sealing of the gas spaces or gas manifolds. Sealing of the gas spaces of PEM fuel cells against outside air is essential for safety and for use of the fuel cell technology.

[0009] Such concepts for phosphoric acid fuel cells (PAFC) have already been described in U.S. Pat. No. 5,407,759. The cell contains phosphoric acid between a pair of electrodes, and a sealing frame of a metal oxide and fluorinated rubber. An additional sealing ribbon is placed between the electrode and the sealing frame.

[0010] Other design concepts for membrane electrode units are described in U.S. Pat. No. 3,134,697 and EP 700 108 A2. These concepts are characterized by the fact that the membrane forms an edge that projects past the electrodes, and which is clamped between the cell plates and, if necessary, between other seals, when the electrodes are sealed.

[0011] Membrane electrode units (MEUs) with projecting membrane edges are, however, susceptible to mechanical damage in production and assembly. Such damages easily result in failure of the cell because the membrane must separate the gas spaces for the reactive gases, hydrogen and oxygen, from each other. Membrane damage occurs particularly easily if very thin membranes (i.e., to 25 μm thickness) are used. That causes problems in MEU production, especially for continuous processes.

[0012] U.S. Pat. No. 3,134,697 discloses another construction method for MEUs, and describes the use of precut frames of polymer material, which are placed around the electrode between the membrane and the bipolar plates.

[0013] Various design geometries for sealed membrane electrode units are suggested in EP 0 586 461 B1. In those, the membrane electrode unit made up of two gas distributor substrates and one membrane is surrounded with elastic sealing material and compressed. Enclosing the MEU and subsequent compression can result in failure of the cell in case of damage or perforation of the membrane.

[0014] U.S. Pat. No. 5,176,966 describes another concept. The porous, electrically conductive gas distributor substrates of the membrane electrode unit completely cover the membrane. That is, the membrane and the gas distributor substrate have the same dimensions and are “coextensive.” The sealing is accomplished by impregnating the carbon fiber substrate (“carbon fiber paper”) with a sealing material around the electrochemically active surface and around the openings for fluid transport.

[0015] DE 197 03 214 describes a membrane electrode unit, which also has a coextensive design, in which the membrane is essentially completely covered on both surfaces by the electrodes or gas distributor substrates. An integral sealing edge is provided around the periphery of the membrane electrode unit, with at least one electrode penetrating the edge region. Except for the front surface, the sealing material does not come into contact with a free membrane surface.

[0016] In the design concepts based on the coextensive design (that is, those in which essentially the entire membrane surface is covered and supported by the gas distributor substrate or the electrode), the poles of the fuel cell (i.e., anode and cathode) are separated by only a few micrometers at the edge (less than 100 μm as a rule). On cutting or separating the MEUs and in other subsequent process steps, there is a danger of the electrodes being short-circuited (by fibers from the gas distributor substrate, for instance). This means that short circuits and failures can often occur in production of MEUs by the coextensive design.

[0017] The gas-tight seal between the reactive oxygen (or air) and hydrogen is another problem in the coextensive design. The seal would require perfect impregnation of the peripheral regions of the gas distributor. But this impregnation would have to extend to the membrane below the gas distributor substrate to prevent hydrogen seeping through to the outer edge of the gas distributor substrate. That is scarcely possible because of the fine pores in the gas distributor substrates and catalyst layers. There is no direct contact of the sealing material with a free surface of the ionically conductive membrane. Therefore there can be increased penetration of hydrogen to the cathode of the membrane electrode unit in the coextensive design. That results in lowering of the open cell voltage (OCV) and, because of that, in a lower electrical capacity of the MEU.

SUMMARY OF THE INVENTION

[0018] Therefore, it was the objective of the present invention to provide a membrane electrode unit, which overcomes the disadvantages of the state of the art and, in particular, proves to be a better design concept.

[0019] This objective is attained by the membrane electrode unit according to claim 1. Advantageous embodiments of the membrane electrode unit are described in the claims. Other claims are directed toward a process for their production, their sealing or impregnation, and use of the membrane electrode unit according to the invention in electrochemical equipment.

[0020] The membrane electrode unit according to the invention has an ionically conductive membrane having a catalyst layer on its front and back sides. They are in turn combined with a gas distributor substrate so that the first gas distributor substrate has a smaller area than the ionically conductive membrane and the second gas distributor substrate essentially covers the membrane. FIGS. 1 and 2 show the structure of the membrane electrode unit according to the invention as cross-sections.

[0021] For a better understanding of the present invention together with other and further advantages and embodiments, reference is made to the following description taken in conjunction with the examples, the scope of the which is set forth in the appended claims.

BRIEF DESCRIPTION OF THE FIGURES

[0022] The preferred embodiments of the invention have been chosen for purposes of illustration and description but are not intended to restrict the scope of the invention in any way. The preferred embodiments of certain aspects of the invention are shown in the accompanying figure, wherein:

[0023] FIG. 1 shows one preferred embodiment of the membrane electrode unit according to the invention, with the "semi-coextensive" design.

[0024] FIG. 2 shows a second preferred embodiment of a MEU according to the invention with semi-coextensive design.

[0025] FIG. 3 is a cross-section showing the seal, sealing, or impregnation of the membrane electrode unit according to the invention with suitable sealing material.

[0026] FIG. 4 is a cross section showing the sealing material impregnated to a depth of at least 1 mm, preferably 3 to 10 mm, into the edge of the gas distributor substrate.

DETAILED DESCRIPTION OF THE PREFERRED EMBODIMENTS

[0027] The present invention will now be described in connection with preferred embodiments. These embodiments are presented to aid in an understanding of the present invention and are not intended to, and should not be construed, to limit the invention in any way. All alternatives, modifications and equivalents that may become obvious to those of ordinary skill upon reading the disclosure are included within the spirit and scope of the present invention.

[0028] FIG. 1 shows one preferred embodiment of the membrane electrode unit according to the invention, with the "semi-coextensive" design. There (1) indicates the ionically conductive membrane, which is in contact with the catalyst layers (2) and (3) at its front and back sides.

[0029] The surface of the first gas distributor substrate (4) is smaller than that of the membrane (1), so that the membrane (1) has a surface (6) on the front side, which is not supported by the gas distributor substrate (4). The entire area of the underside of the membrane (1) is in contact with the catalyst layer (3), and the entire surface is supported by gas distributor substrate (5). The smaller gas distributor substrate is centered on the membrane. In the finished membrane electrode unit, the distance from the outer edge of the smaller first gas distributor substrate (4) to the outer edge of the larger second gas distributor substrate (5) is at least 1 mm all the way around, and preferably at least 2 mm. The catalyst layers (2) and (3) have different surface dimensions; that is, they are not equally large.

[0030] FIG. 2 shows a second preferred embodiment of a MEU according to the invention with semi-coextensive design. The design is essentially comparable with FIG. 1, but the catalyst layers (2) and (3) have the same surface dimensions. The area of the first gas distributor substrate (4) is smaller than that of the membrane (1), so that the membrane (1) again has a surface (6) which is not supported by the gas distributor substrate (4). In this embodiment, though, the catalyst layers (2) and (3) have the same surface dimensions as the ionically conductive membrane (1).

[0031] FIG. 3 is also a cross-section showing the seal, sealing, or impregnation of the membrane electrode unit according to the invention with suitable sealing material (7). Here the edge of the gas distributor substrate (4, 5) and the surface (6) of the ionically conductive membrane (1) not supported by a gas distributor substrate are surrounded by a sealing material (7).

[0032] In this embodiment, it is preferable for the sealing material to be impregnated to a depth of at least 1 mm, preferably 3 to 10 mm, into the edge of the gas distributor substrate (4, 5), as shown in FIG. 4. These additionally

impregnated places in the gas distributor substrate are indicated in this figure with (7a).

[0033] Presence of a free membrane surface not supported or covered by a gas distributor substrate is an essential feature of the membrane electrode unit with semi-coextensive design according to the invention. It has been found, surprisingly, that exactly that circumstance achieves significantly better gas-tightness in the sealing of the edge regions of the membrane electrode unit.

[0034] That is of particularly great importance because so-called "hot spots" at which the hydrogen is burned catalytically can occur on the oxygen side of the fuel cell in case of increased penetration by hydrogen. That can result in failure of the cell after very brief use. But such effects can occur especially with longer-term use of the MEU in a PEM fuel cell stack, and substantially shorten the life of the stack. A drop in the open cell voltage with no current (OCV) to a value below 920 mV is a sign of increased penetration of hydrogen to the oxygen side of the fuel cell. The hydrogen penetration can also be measured as a penetration current by means of cyclic voltammetry. Values greater than 1.5 mA/cm² for the penetration current density indicate leakages. The measurement methods depicted are used in the present application to document the improved characteristics of the membrane electrode unit with semi-coextensive design.

[0035] Another advantage of the MEU according to the invention is that it has a stable structure, which can be manipulated well because of the structure described. The two poles or electrodes of the membrane electrode unit are farther separated spatially at the edge region because of the structure according to the invention. On cutting or separating the MEUs and in other subsequent processing steps, there is no danger that the poles will be short circuited by, for instance, fibers from the gas distributor substrates.

[0036] The membrane electrode units according to the invention can be produced with the current processes known to those skilled in this area of the art.

[0037] For example, one route goes by sealing together or laminating two catalyst-coated gas distributor substrates on the front and back side of the ionically conductive membrane. The gas distributor substrates used, having different surface dimensions, are coated with inks containing catalysts and dried. Then that is pressed, with application of heat and pressure, with a membrane, with surface dimensions corresponding to those of the larger gas distributor substrate. The gas distributor substrate can comprise porous, electrically conductive materials such as carbon fiber paper, carbon fiber nonwoven cloth, carbon fiber cloth, metal mesh, metallized fibrous cloth and the like (so-called "processing on catalyst-coated gas distributor substrate").

[0038] Alternatively, catalyst coated membranes ("CCMs") can also be used. Then, in another combining step, one applies gas distributor substrates, which are usually not coated with the catalyst, to the catalyst layers applied directly onto the membrane. In this process it is important that one of the two gas distributor substrates essentially covers the membrane and that the second gas distributor substrate be smaller than the membrane (so-called "processing on catalyst-coated membranes").

[0039] Obviously, mixed forms and combinations of these two processes can also be used to make the MEUs according to the invention.

[0040] Organic polymers which are inert under the operating conditions of the fuel cell and which do not release any poisoning substances can be used to seal the membrane electrode units according to the invention. The polymers must be able to make a gas-tight enclosure around the gas distributor substrate. Other important requirements for such a polymer are good ability to adhere and good wetting properties on the free surface of the ionically conductive membrane.

[0041] One group of suitable materials is thermoplastic polymers such as polyethylene, polypropylene, PTFE, ethylene-propylene copolymer (EPDM), polyamide, polyimide, polyurethane or polyester. Another group is thermosetting polymers such as epoxy resins or cyanoacrylates. Elastomers such as silicone rubber or EPDM are also suitable.

[0042] The polymer can be used both in the form of a precut film frame, or as a liquid or molding paste, to apply the polymeric sealing material.

[0043] When precut films are used to seal the membrane electrode unit according to the invention, they can be inserted between two appropriately precut frames of thermoplastic material in a press. The frames are cut so that the interior cutouts enclose the form of the particular active surface as exactly as possible. Then the polymeric film material is melted with use of heat and pressure. After that, it surrounds the outer region of the semi-coextensive gas distributor substrates and the free surface of the membrane.

[0044] When the polymeric sealing material is used in liquid form or as a molding paste, the polymer is first applied to the edge region of the membrane electrode unit with the usual application methods such as doctor blades, spraying, immersing, injection molding, and various printing techniques. Then the polymer is shaped and cured. Special structures can be formed in the process, according to the design of the cell plates of the fuel cell stack. The curing of the polymeric sealing material can be accomplished by contact with moisture in the air and/or at elevated temperature, depending on the type and nature of the polymer.

[0045] It is also possible to impregnate the peripheral region of the gas distributor substrate of the membrane electrode unit according to the invention with the thermoplastic polymer material so that it is gas-tight. To do so, the polymer frames are cut so that their inner cutouts are somewhat smaller than the surface of the smaller gas distributor substrate of the membrane electrode unit. The polymer material is melted with application of heat and pressure. Then it impregnates the peripheral region of the two semi-coextensive gas distributor substrates, going through to the membrane, and surrounds the open surface of the membrane and the gas distributor structures.

[0046] Still another possibility for doing this involves binding a precut outer frame to the MEU according to the invention by means of a liquid polymeric sealing material. The membrane electrode unit which is finally completed in this manner is a one-piece composite which can be manipulated mechanically well, which can be incorporated into a fuel cell stack by a simple process.

[0047] Having now generally described the invention, the same may be more readily understood through the following reference to the following examples, which are provided by way of illustration and are not intended to limit the present invention unless specified.

EXAMPLES

[0048] The following examples are intended to explain embodiments of the invention.

Example 1

[0049] Production of a membrane electrode unit according to the invention with semi-coextensive design.

[0050] First, two catalyst-coated gas distributor substrates, each with a platinum loading of 0.25 mg Pt/cm² are prepared. Nonwoven carbon fiber cloth of the SIGRACET 30BC type (hydrophobized, with microporous layer; SGL Co., Meitingen) is used. Special patterns are used to make

[0051] a) gas distributor substrate A with dimensions of 73×73 mm;

[0052] b) gas distributor substrate B with dimensions of 75×75 mm; and

[0053] c) Nafion 112 (membrane (DuPont Fluoroproducts, Fayetteville, USA) with dimensions of 75×75 mm.

[0054] The gas distributor substrates A and B are positioned on the sides of the membrane with their catalyst-coated sides turned toward the membrane, and with the smaller gas distributor substrate A centered on the membrane. Then the structure is pressed at 150° C. and a pressure of 150 N/cm². The finished membrane electrode unit has a semi-coextensive design with a 1 mm edge of free membrane.

[0055] To seal the MEU produced in that manner, frames 0.21 mm thick are cut from a polyamide film (Type: Vestamelt 3261, Epurex Company, Walsrode) in the sizes

[0056] a) 100×100 mm outside dimensions and 71×71 mm inside dimensions, and

[0057] b) 100×100 mm outside dimensions and 75×75 mm inside dimensions.

[0058] The membrane electrode unit is centered, with the gas distributor substrate B down, on a frame (0.210 mm thick) with the inside cutout dimensions 71×71 mm. Another frame (total thickness 0.210 mm) with inside cutout dimensions 75×75 mm is placed around the outside of the membrane electrode unit. Similarly, a frame (0.210 mm thick) with inside cutout dimensions 71×71 mm is centered on the surface of the smaller gas distributor substrate A.

[0059] The entire assembly is packaged between two release films and initially heated in a hot press for 90 seconds without pressure at a plate temperature of 165° C. Then the press force is raised to 10 metric tons and the assembly is pressed for 30 under that force. Then it is cooled to room temperature. The finished membrane electrode unit with semi-coextensive design has a smooth, transparent plastic edge, which adheres very well to the MEU.

Comparison example 1 (VB 1)

[0060] A membrane electrode unit with coextensive design is produced in principle as described in Example 1, but both the gas distributor substrates used (A, B) and the membrane have the same surface dimensions of 73×73 mm. The MEU does not have an edge of free membrane.

[0061] The sealing of the MEU is done as in Example 1, using the same polyamide film and with the same process parameters. The MEU has a smooth, transparent plastic edge which has less adhesion to the MEU than Example 1.

[0062] Electrochemical tests

[0063] The completely sealed membrane electrode units from Example 1 and the Comparison Example (VB 1) were tested in a PEM test cell having an active cell area of 50 cm², in hydrogen/air operation. First, the open cell voltage without a current load was measured (“OCV”). Then the amount of hydrogen penetrating from the anode side to the cathode side was measured (“hydrogen penetration current”) by means of cyclic voltammetry (CV). Table 1 shows a comparison of the values measured. It becomes clear that the gas spaces in the membrane electrode unit according to the invention are sealed off from each other better than in the comparison MEU with “coextensive” design

Comparison Example VB1

[0064]

TABLE 1

Comparison of the open cell voltage (OCV) and the hydrogen penetration current of membrane electrode units with “coextensive” and “semi-coextensive” design.			
	Design	Open cell voltage [OCV, mV]	Hydrogen penetration current [mA/cm ²]
Comparison example (VB 1)	coextensive	890	>4
Example 1	semi-coextensive	950	0.89

[0065] While the invention has been described in connection with specific embodiments thereof, it will be understood that it is capable of further modifications and this application is intended to cover any variations, uses, or adaptations of the invention following, in general, the principles of the invention and including such departure from the present disclosure as come within known or customary practice within the art to which the invention pertains and as may be applied to the essential features hereinbefore set forth and as follows in the scope of the appended claims.

What is claimed:

1. A membrane electrode unit for electrochemical equipment, containing an ionically conductive membrane with a front and back side, a first catalyst layer and a first gas distributor substrate on the front side and a second catalyst layer and a second gas distributor substrate on the back side, in which the first gas distributor substrate has lesser surface dimensions than the ionically conductive membrane and the second gas distributor substrate has essentially the same surface dimensions as the ionically conductive membrane.

2. A membrane electrode unit according to claim 1, wherein the catalyst layer on the front side and the catalyst

layer on the back side of the ionically conductive membrane have different surface dimensions.

3. A membrane electrode unit according to claim 1, wherein the catalyst layer on the front side and the catalyst layer on the back side of the ionically conductive membrane have the same surface dimensions.

4. A membrane electrode unit according to claim 1, wherein the ionically conductive membrane on the front side has a surface that is not supported by a gas distributor substrate.

5. A membrane electrode unit according to claim 1, wherein the catalyst layers on the front side and on the back side contain catalysts containing noble metals and optionally ionically conductive materials.

6. A membrane electrode unit according to claim 1, wherein the ionically conductive membrane comprises organic polymers, such as proton-conducting perfluorinated polymeric sulfonic acid compounds, doped polybenzimidazoles, polyether ketones, polysulfones or ionically conducting ceramic materials, and has a thickness of 10 to 200 μm .

7. A membrane electrode unit according to claim 1, wherein the gas distributor substrate comprises porous electrically conductive materials containing carbon fiber paper, carbon fiber nonwoven cloth, carbon fiber cloth, metal mesh, metallized fiber cloth, or combination thereof.

8. A membrane electrode unit according to claim 1, wherein the edge of the gas distributor substrate and the free surface of the ionically conductive membrane not supported by a gas distributor substrate are surrounded by a sealing material.

9. A membrane electrode unit according to claim 8, wherein the sealing material additionally impregnates an edge region of the gas distributor substrates to a depth of at least 1 mm.

10. A membrane electrode unit according to claim 8, wherein the sealing material contains thermoplastic poly-

mers of polyethylene, polypropylene, polytetrafluoroethylene, PVDF, EPDM, polyester, polyamide, polyamide elastomers, polyimide, polyurethane, silicone, silicone elastomers, or combinations thereof and/or thermosetting polymers of epoxides, cyanoacrylates or combinations thereof.

11. A membrane electrode unit according to claim 8, wherein the sealing material is integrally combined with another peripheral plastic frame.

12. A process for producing a membrane electrode unit according to claim 1, comprising combining two catalyst-coated gas distributor substrates with the front and back sides of an ionically conductive membrane.

13. A process for producing a membrane electrode unit according to claim 1, comprising combining two gas distributor substrates which are not catalyst-coated with the front and back sides of an ionically conductive membrane coated with catalyst on both sides.

14. A process for producing a membrane electrode unit according to claim 8, wherein the surface of the ionically conductive membrane not supported by a gas distributor substrate is brought directly into contact with sealing material.

15. A process for producing a membrane electrode unit according to claim 14, wherein the sealing material is cured by elevated pressure and elevated temperature or by contact with air moisture and/or elevated temperature.

16. Use of the membrane electrode units according claim 1 to produce cell stacks for electrochemical equipment.

17. Use of the membrane electrode units according to claim 1 to produce a fuel cell.

* * * * *