

US 20040252748A1

(19) **United States**

(12) **Patent Application Publication**
Gleitman

(10) **Pub. No.: US 2004/0252748 A1**

(43) **Pub. Date: Dec. 16, 2004**

(54) **FIBER OPTIC SENSING SYSTEMS AND METHODS**

(52) **U.S. Cl. 374/130; 374/161**

(76) **Inventor: Daniel D. Gleitman, Houston, TX (US)**

(57) **ABSTRACT**

Correspondence Address:
KONNEKER & SMITH P. C.
660 NORTH CENTRAL EXPRESSWAY
SUITE 230
PLANO, TX 75074 (US)

Fiber optic sensing systems and methods. In a described embodiment, a fiber optic sensing system includes an optical fiber transmitting energy to a chemical vapor deposited diamond material proximate a substance in a well. The diamond material is deposited as a coating on a substrate. The substrate and coating are heated when the energy is transmitted by the optical fiber. This heats the substance in the well, which is detected to determine a property of the substance. In another embodiment, light energy is transmitted through the diamond material.

(21) **Appl. No.: 10/461,977**

(22) **Filed: Jun. 13, 2003**

Publication Classification

(51) **Int. Cl.⁷ G01K 11/00; G01J 5/00**

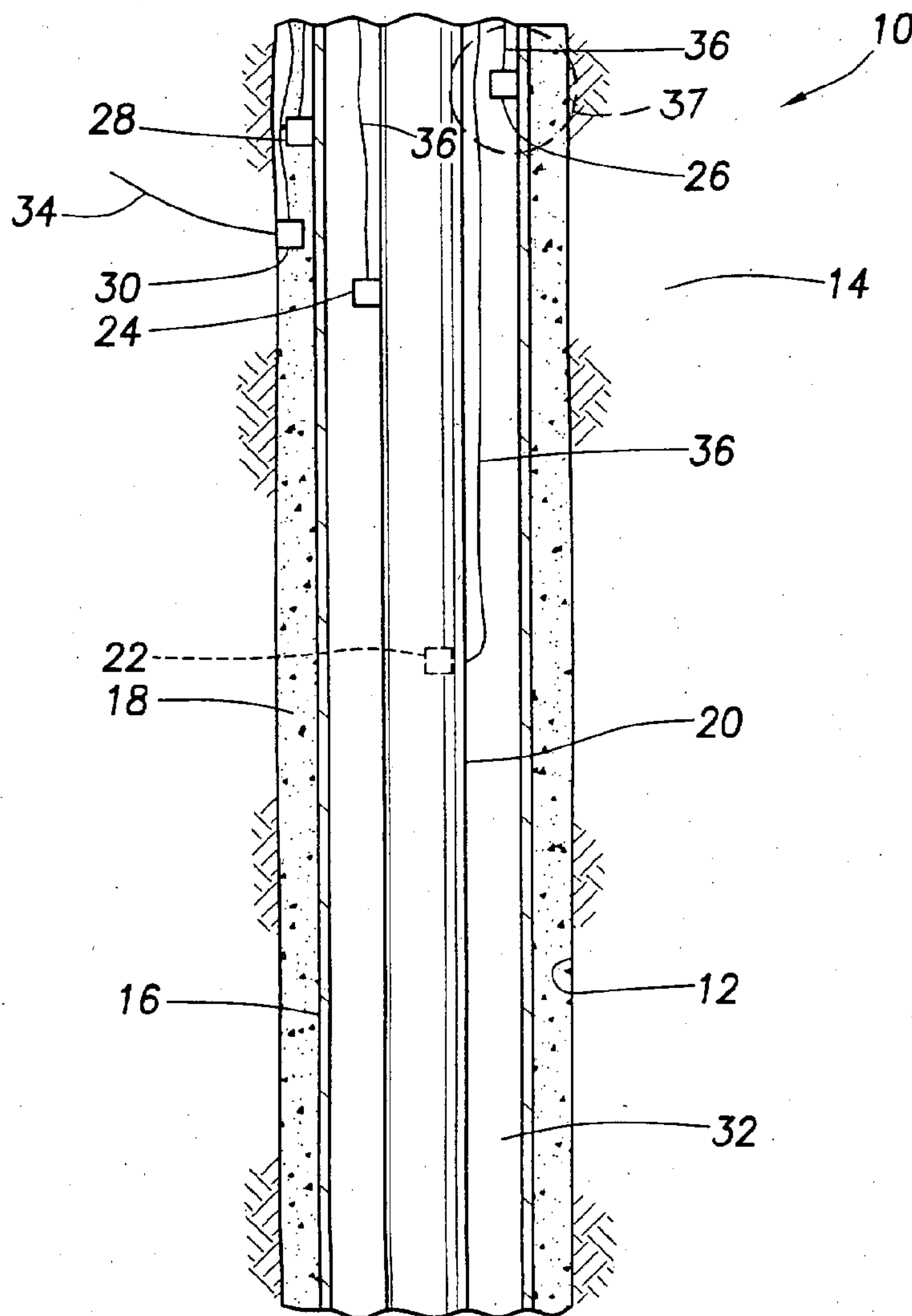

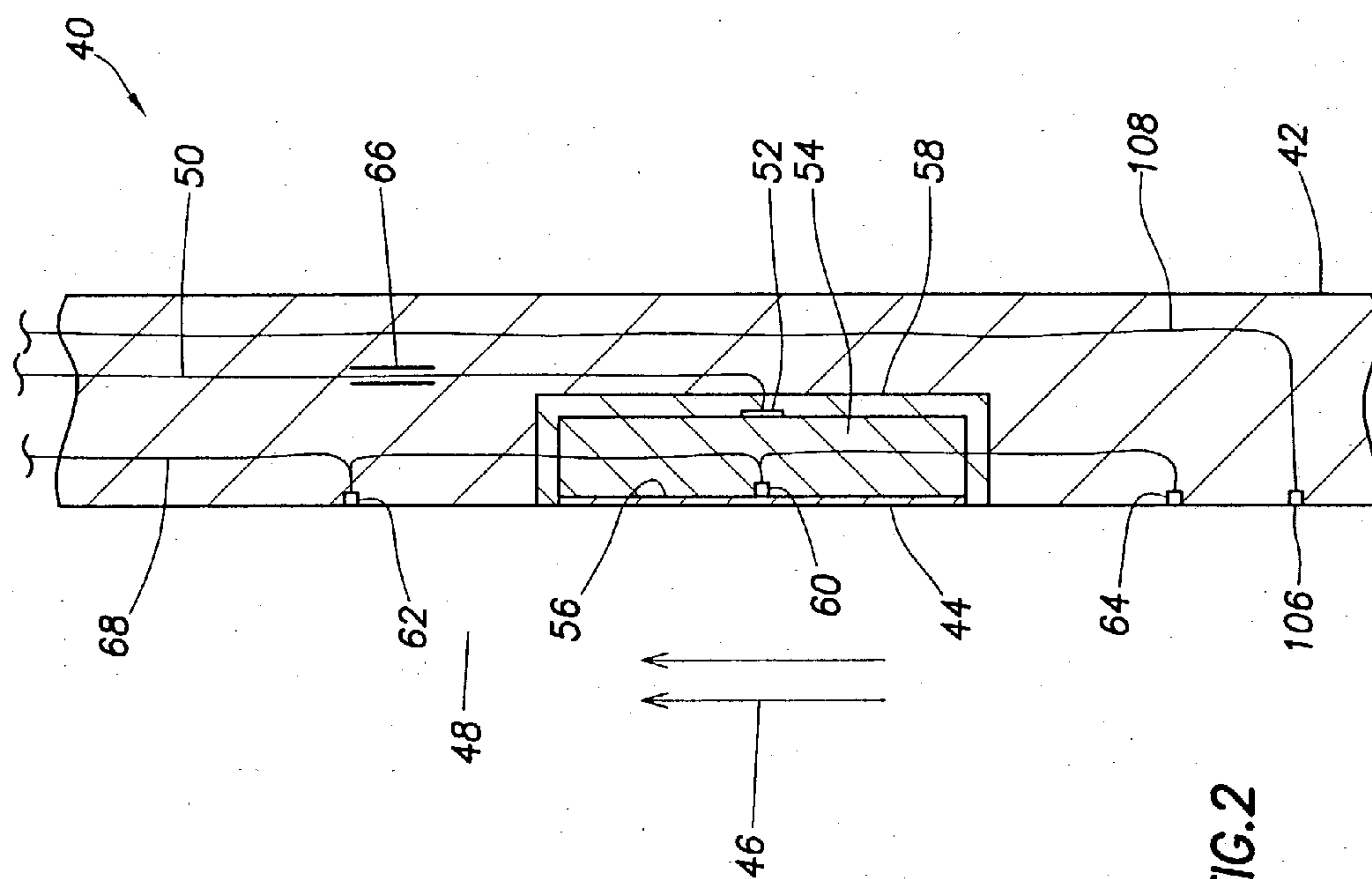

FIG. 2

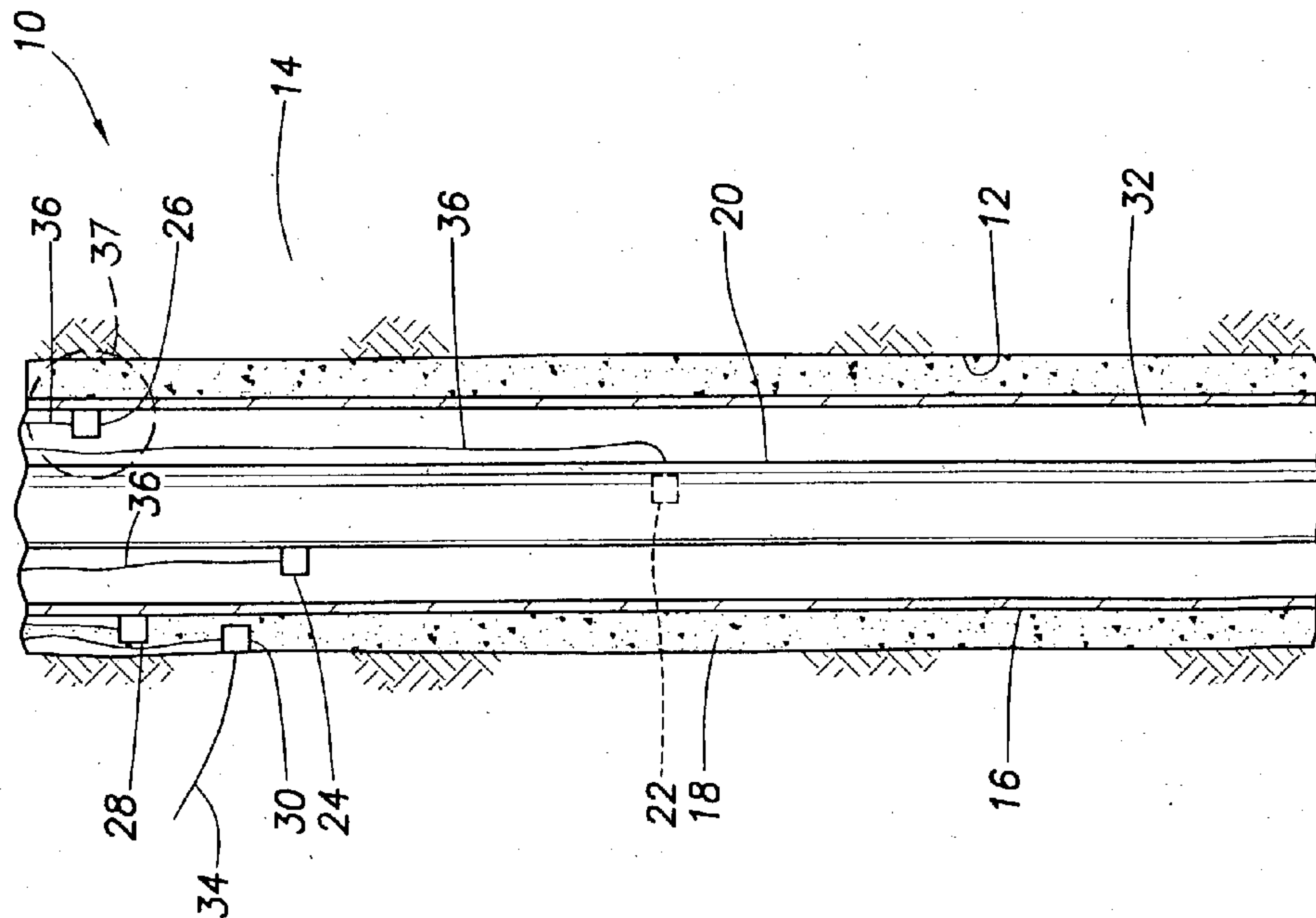

FIG. 1

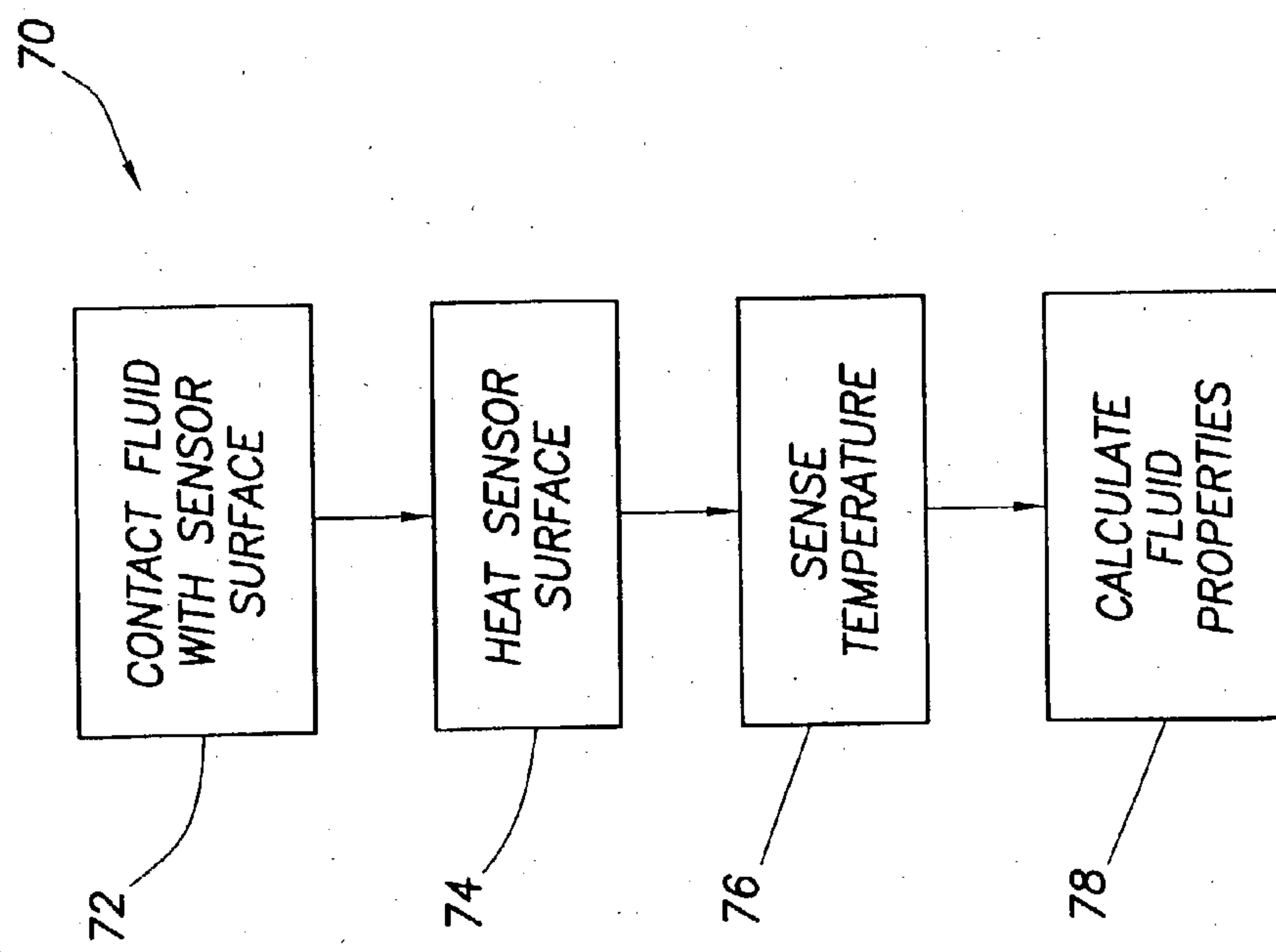

FIG.3

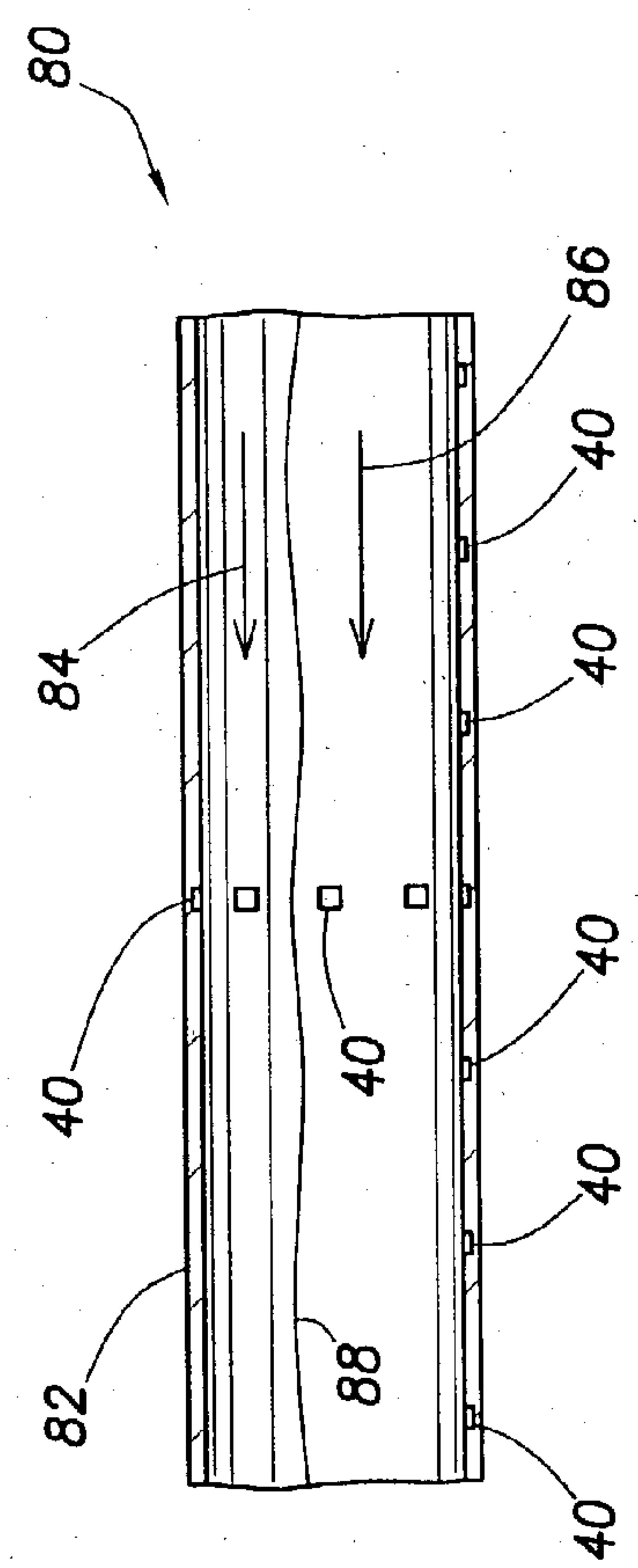

FIG.4

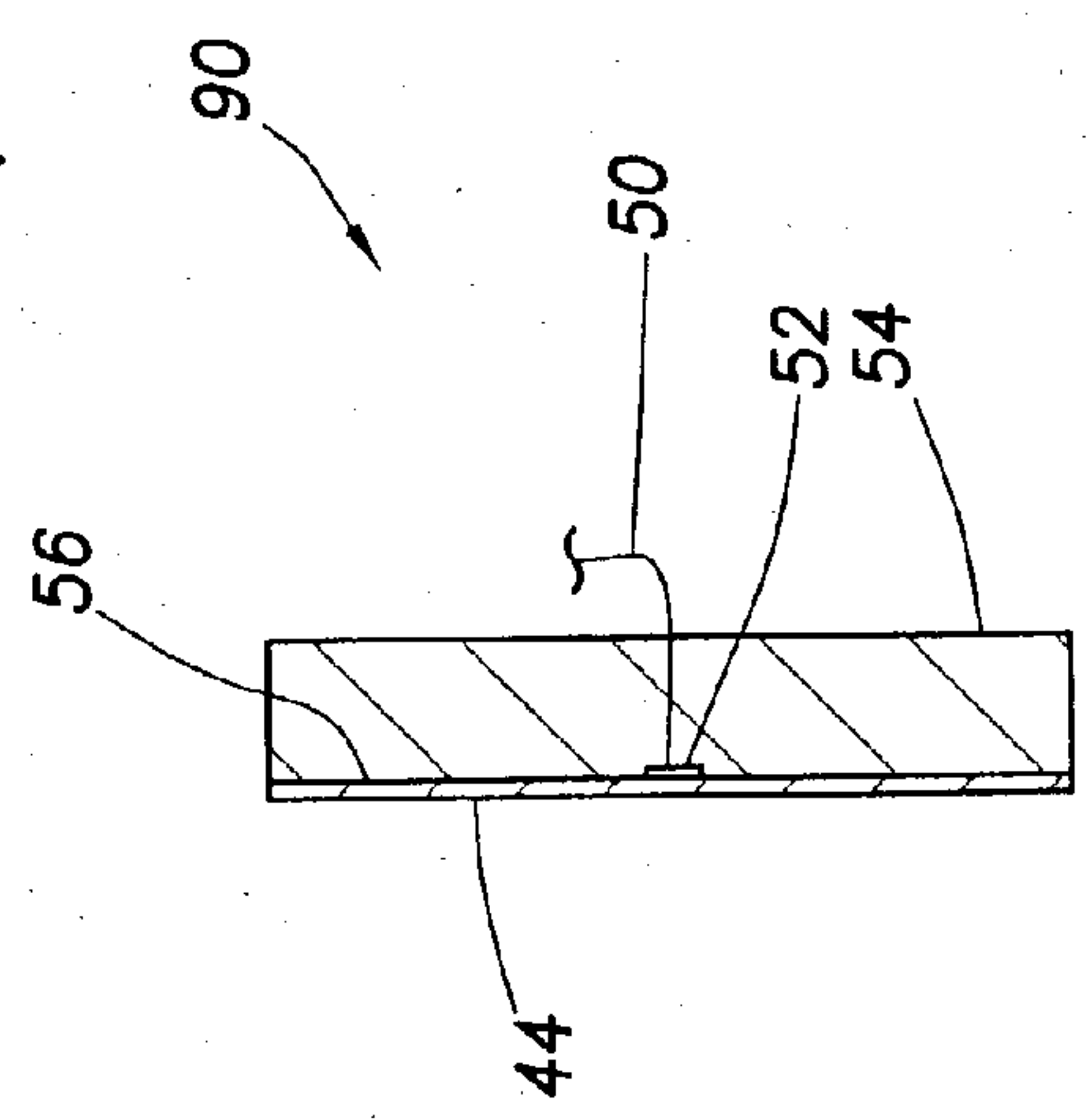

FIG.5

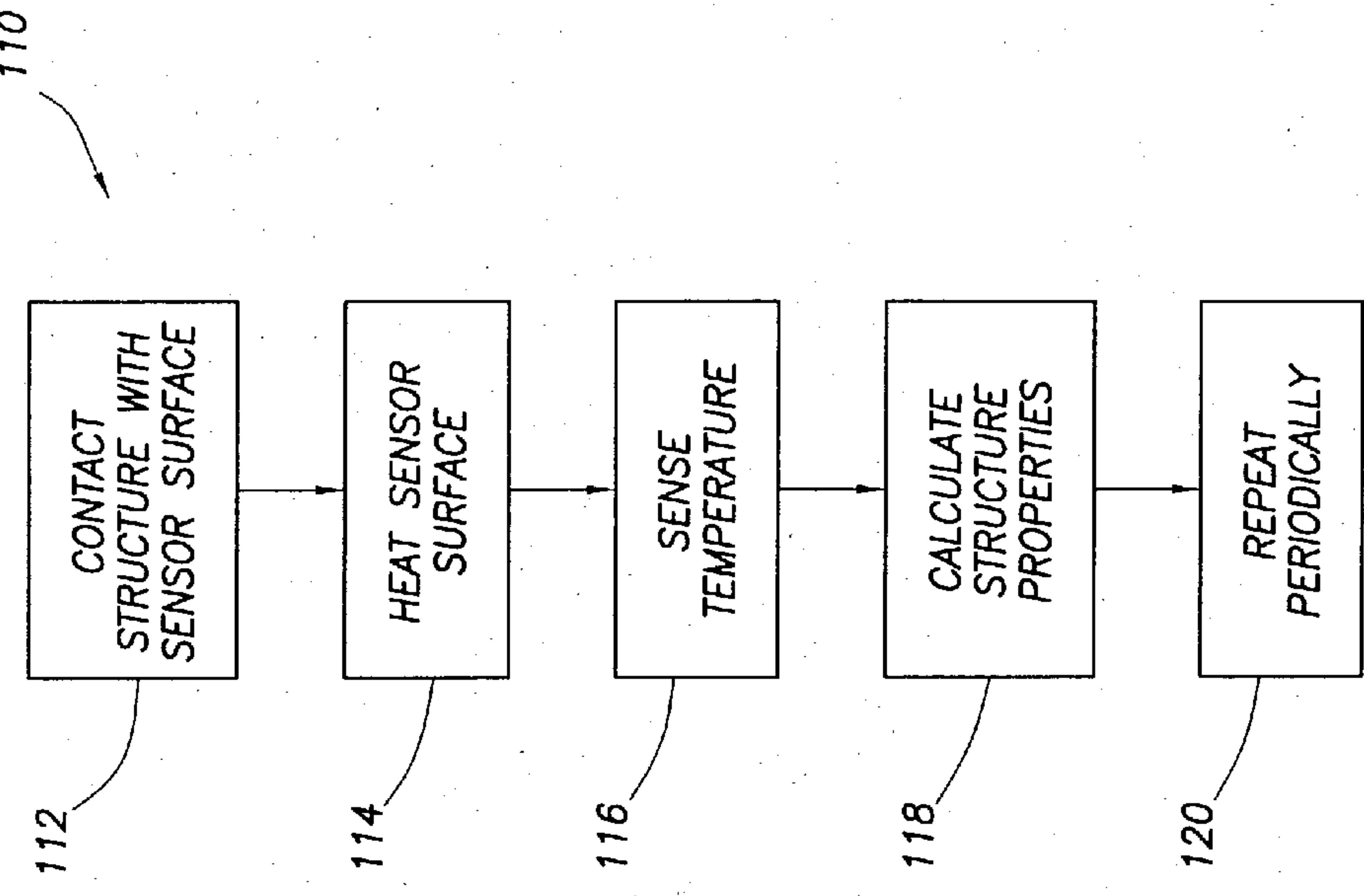

FIG.7

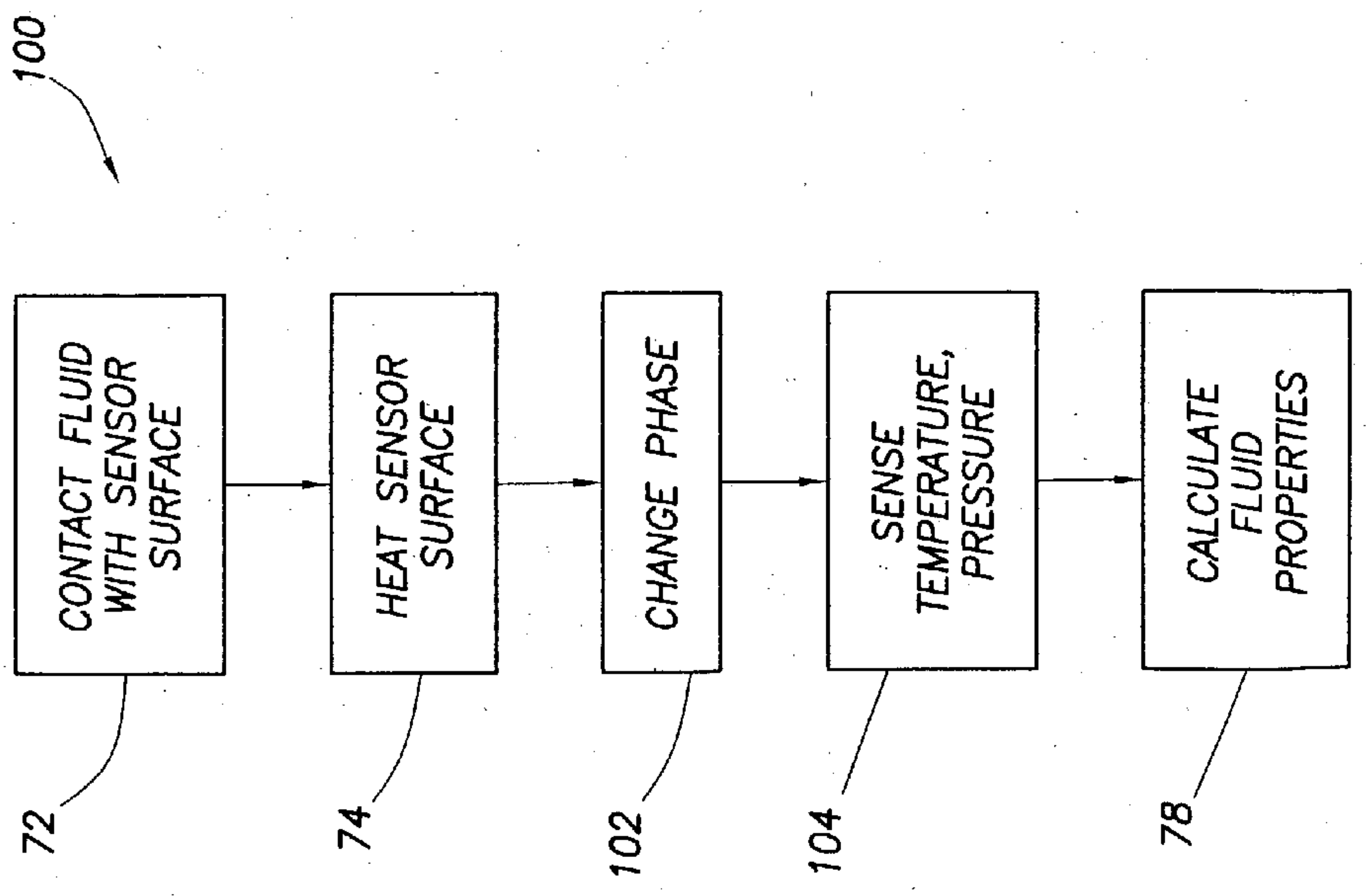

FIG.6

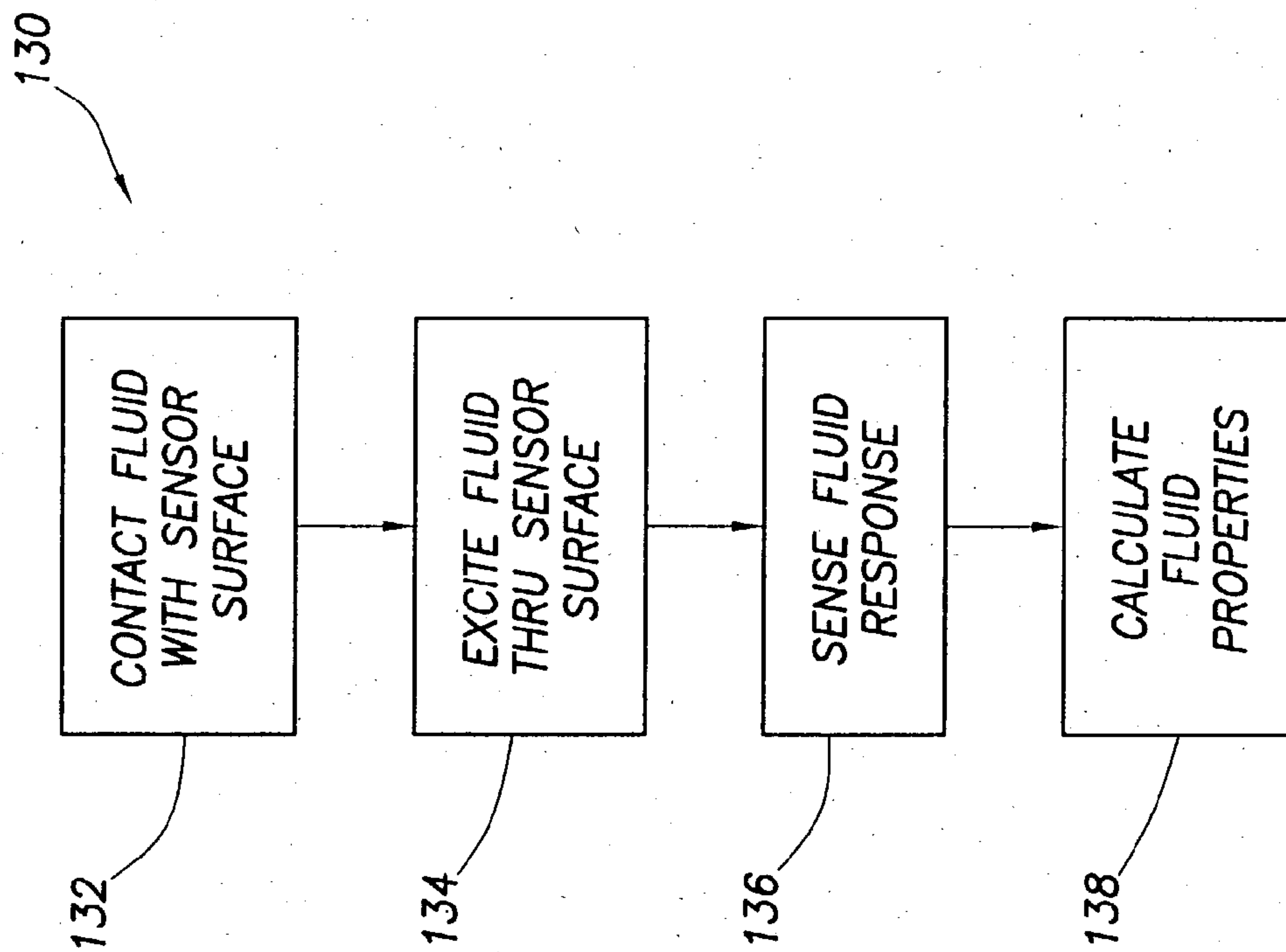

FIG.9

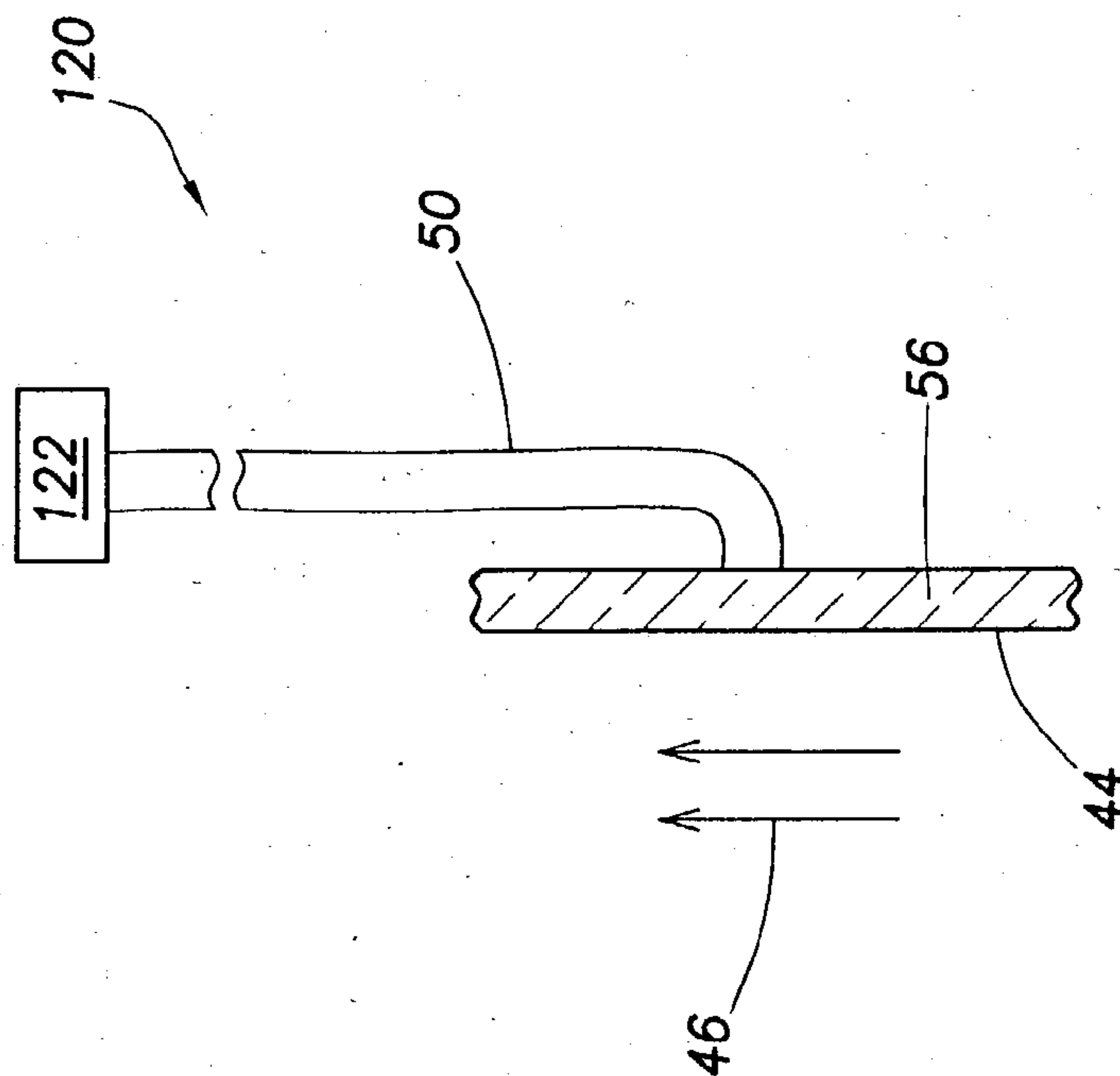

FIG.8

FIBER OPTIC SENSING SYSTEMS AND METHODS

BACKGROUND

[0001] The present invention relates generally to equipment utilized and operations performed in conjunction with a subterranean well and, in an embodiment described herein, more particularly provides a fiber optic sensing system and method for measuring properties, such as heat transfer characteristics, of substances and environments in wells and other locations.

[0002] It is frequently desirable to be able to detect or measure various properties of substances in a well. For example, it may be desirable to determine a rate of flow of fluid from a producing zone, determine the composition of a fluid mixture in the well, evaluate the quality of a cementing operation, locate a fluid interface (i.e., liquid/liquid or gas/liquid) in the well or in a formation intersected by the well, etc.

[0003] Typically, certain measurements are made by conveying a logging tool into the well and using sensors, such as flowmeters and thermocouples, to detect properties of fluid in the well. Unfortunately, the logging tool obstructs a passage for flow of fluid in the well, thereby interfering with production. It is also somewhat time-consuming and costly to make such logging trips into the well. This is particularly so if it is desired to periodically perform the measurements to track changes in the well over time, such as to evaluate the migration of an oil/water interface in a formation drained by the well.

[0004] Some fiber optic measurement systems have been developed for permanent installation in a well. However, these are very expensive, and their principles of operation make the measurements obtained using these systems possibly unreliable at certain flow rates, flow regimes and/or hydrocarbon combinations, etc.

[0005] Therefore, it may be seen that it would be beneficial to provide improved systems and methods for sensing properties of substances in a well. These systems and methods would preferably, but not necessarily, eliminate any obstruction to fluid flow through the well, be configured for permanent installation in the well, be convenient in use and provide reliable results.

[0006] Furthermore, it would be desirable for such systems and methods to be versatile in application to, for example, pipelines, chemical processes, on the surface, remotely controlled and/or monitored, etc. Other examples include production infrastructure immediately downstream of a well, e.g., sea bed flowlines and manifolds, subsea or surface wellheads, risers and production platform pipes. Sensing systems installed at these locations may be used along with other sensors for monitoring of production parameters, as well as formation and deposition of waxes, asphaltines and hydrates.

SUMMARY

[0007] In carrying out the principles of the present invention, in accordance with an embodiment thereof, fiber optic sensing systems and methods are provided which solve one or more of the above problems in the art. A sensing system described herein is suitable for permanent installation in a

well, does not interfere with fluid flow or production, and utilizes a unique method of operation to detect properties of substances in the well.

[0008] In one aspect of the invention, a fiber optic sensing system for sensing at least one property of a substance is provided. The system includes a sensor surface in contact with the substance. An optical fiber transmits energy to the sensor surface. The sensor surface, in turn, transmits energy to the substance.

[0009] In another aspect of the invention, a fiber optic sensing system for use in detecting at least one property of a substance in a well is provided. The sensing system includes a sensor surface configured for contacting the substance in the well, an optical fiber for transmitting energy to the sensor surface and a temperature sensor for detecting a temperature of the substance. The sensor surface is heated when energy is transmitted by the optical fiber.

[0010] In yet another aspect of the invention, another fiber optic sensing system is provided. The sensing system includes a sensor surface configured for contacting the substance in the well and an optical fiber for transmitting light energy to the sensor surface. The light energy is transmitted from the optical fiber through the sensor surface and to the substance. The light energy produces a response in the substance, such as a temperature change, fluorescence or a spectral emission.

[0011] In still another aspect of the invention, a method of detecting at least one property of a substance in a well is provided. The method includes the steps of: positioning a sensor surface in the well in contact with the substance; transmitting energy through an optical fiber to the sensor surface, thereby heating the sensor surface and the substance in contact with the sensor surface; and detecting a temperature of the heated substance.

[0012] In a further aspect of the invention, another method of detecting at least one property of a substance in a well is provided. The method includes the steps of: positioning a sensor surface in the well in contact with the substance; transmitting light energy through an optical fiber to the sensor surface; transmitting the light energy through the sensor surface to the substance; and detecting a response of the substance to the transmitted light energy.

[0013] These and other features, advantages, benefits and objects of the present invention will become apparent to one of ordinary skill in the art upon careful consideration of the detailed description of representative embodiments of the invention hereinbelow and the accompanying drawings.

BRIEF DESCRIPTION OF THE DRAWINGS

[0014] FIG. 1 is a schematic partially cross-sectional view of a first fiber optic sensing system embodying principles of the present invention;

[0015] FIG. 2 is an enlarged schematic cross-sectional view of a first fiber optic sensor embodying principles of the present invention;

[0016] FIG. 3 is a flowchart of steps in a first method embodying principles of the present invention;

[0017] FIG. 4 is a schematic cross-sectional view of a second fiber optic sensing system embodying principles of the present invention;

[0018] FIG. 5 is a schematic cross-sectional view of a second fiber optic sensor embodying principles of the present invention;

[0019] FIG. 6 is a flowchart of steps in a second method embodying principles of the present invention;

[0020] FIG. 7 is a flowchart of steps in a third method embodying principles of the present invention;

[0021] FIG. 8 is a schematic cross-sectional view of a third fiber optic sensor embodying principles of the present invention; and

[0022] FIG. 9 is a flowchart of steps in a fourth method embodying principles of the present invention;

DETAILED DESCRIPTION

[0023] Representatively and schematically illustrated in FIG. 1 is a fiber optic sensing system 10 which embodies principles of the present invention. In the following description of the system 10 and other apparatus and methods described herein, directional terms, such as “above”, “below”, “upper”, “lower”, etc., are used only for convenience in referring to the accompanying drawings. Additionally, it is to be understood that the various embodiments of the present invention described herein may be utilized in various orientations, such as inclined, inverted, horizontal, vertical, etc., and in various configurations, without departing from the principles of the present invention.

[0024] The sensing system 10 is depicted in FIG. 1 as being installed in a well which includes a wellbore 12 intersecting an earth formation 14. The wellbore 12 is lined with protective casing or liner 16. A hardenable material 18, such as cement, epoxy, etc., is positioned between the casing 16 and the wellbore 12.

[0025] As used herein, the terms “casing” and “liner” are used to indicate any protective wellbore lining including, but not limited to, segmented or continuous tubular strings, rigid or expandable structures, made from steel, plastics or any other material, etc.

[0026] A tubular string 20, such as a production tubing string, is positioned in the casing 16 for flowing fluids from the well to the earth’s surface, subsea wellhead, etc. However, it should be clearly understood that the principles of the invention may be practiced in circumstances other than a producing well, such as in an injection well or a combined production and injection well.

[0027] A fiber optic sensing device 22 is positioned in the tubular string 20 to detect properties of fluid flowing through the tubular string. Another fiber optic sensing device 24 is positioned external to the tubular string 20 to detect properties of the tubular string itself and/or to detect properties of fluid in an annulus 32 external to the tubular string. In actual practice, the sensing devices 22, 24 would preferably be configured so that they are disposed in a sidewall of the tubular string 20.

[0028] Another fiber optic sensing device 26 is positioned within the casing 16 to detect properties of the casing itself and/or to detect properties of fluid disposed in the annulus 32 between the tubular string 20 and the casing. Another fiber optic sensing device 28 is positioned external to the casing 16 to detect properties of the cement 18 and/or properties of

fluids in the cement. In actual practice, the sensing devices 26, 28 would preferably be configured so that they are disposed in a sidewall of the casing 16.

[0029] Yet another fiber optic sensing device 30 is positioned adjacent the formation 14 to detect properties of the formation itself and/or to detect properties of fluid in the formation. For example, the sensing device 30 may be used to detect the progress or presence of a fluid interface 34 in the formation 14, such as an oil/water interface. In actual practice, the sensing device 30 may be conveyed into the well attached to the casing 16, or the sensing device could be flowed into the well along with the cement 18 as described in U.S. Pat. No. 6,408,943, the entire disclosure of which is incorporated herein by this reference.

[0030] The sensing system 10 illustrated in FIG. 1 includes the various sensing devices 22, 24, 26, 28, 30 to demonstrate the broad variety of applications of the principles of the invention to the problems of detecting properties of substances in a well. An actual well installation would not necessarily include all of the sensing devices 22, 24, 26, 28, 30, and might include other sensing devices which embody principles of the invention. It is also not necessary for the well to be cased, to have any tubular string therein, or to be a production well. Thus, it should be clearly understood that the sensor system 10 depicted in FIG. 1 is given only as an example of some of the uses of the inventive concepts described below, and these inventive concepts are in no way limited to the specific details of the sensor system of FIG. 1.

[0031] It will be appreciated that the sensing devices 22, 24, 26, 28, 30 detect properties of a variety of substances in the well. These substances are: 1) fluid flowing through the tubular string 20, 2) the tubular string itself, 3) fluid in the annulus 32 external to the tubular string, 4) the casing 16, 5) the cement 18, 6) fluid in the cement, 7) the formation 14, and 8) fluid in the formation. Of course, properties of substances other than, or in addition to, these may be detected without departing from the principles of the invention. In addition, or alternatively, the sensing devices 22, 24, 26, 28, 30 may detect properties of the environment or location, such as heat capacity, heat transfer, etc.

[0032] The sensing devices 22, 24, 26, 28, 30 are described herein as “fiber optic” sensing devices, since they each include an optical fiber 36 connected thereto for operation of the sensing device. An individual optical fiber 36 is illustrated for each of the sensing devices 22, 24, 26, 28, 30 in FIG. 1, but a single optical fiber may be used for more than one sensing device, if desired. For example, known optical multiplexing techniques may be used to permit multiple downhole sensing devices to be operated and/or communicated with via a single optical fiber.

[0033] The optical fiber 36 may be installed in a capillary tube inside or outside of the tubular string 20, before or after the capillary tube is installed in the well, for example, as described in U.S. Pat. Nos. 5,163,321 and 4,976,142, the disclosures of which are incorporated herein by this reference. The sensing devices 22, 24, 26, 28, 30 may be connected to the optical fiber 36 before or after installation in the well, for example, the optical fiber may be “stabbed into” the sensing devices after they are installed in the well. Furthermore, the optical fiber 36 and/or any of the sensors 22, 24, 26, 28, 30 may be integrated into the construction of

any structure in the well, for example, integrated into the sidewall of a tubular string as described in U.S. Patent Application Publication No. 2002/0007945, the entire disclosure of which is incorporated herein by this reference.

[0034] The sensing system **10** utilizing the optical fiber **36** and one or more of the sensing devices **22, 24, 26, 28, 30** will typically also include an instrument at the surface or another remote location (not shown in **FIG. 1**, but see the detector **122** depicted in **FIG. 8**). The instrument may provide light energy, receive the sensing device(s) response, perform signal analysis, including optical signal processing, and may be packaged in one or more individual components in one or more physical locations, etc. For example, a single instrument may be used in conjunction with a single optical fiber **36**, multiple instruments may be used in conjunction with multiple optical fibers, and any combination thereof.

[0035] Referring additionally now to **FIG. 2**, a fiber optic sensing device **40** embodying principles of the invention is representatively illustrated. The sensing device **40** may be used for any of the sensing devices **22, 24, 26, 28, 30** described above, or the sensing device **40** may be used in other sensing systems. The sensing device **40** is depicted as being positioned in a sidewall of a tubular string **42**, such as the tubular string **20** or casing **16** depicted in **FIG. 1**, but it should be understood that the sensing device may be otherwise positioned in keeping with the principles of the invention.

[0036] As shown in **FIG. 2**, a surface **44** of the sensing device **40** is positioned in contact with a fluid (indicated by arrows **46**) flowing through a passage **48** in the tubular string **42**. This configuration corresponds to the sensing device **22** in the tubular string **20**, or the sensing device **26** in the casing **16**, in **FIG. 1**. Alternatively, the fluid **46** could be external to the tubular string **42**, with the surface **44** of the sensing device **40** facing outwardly, which would correspond to the sensing device **24** on the tubular string **20**, or to the sensing device **28** on the casing **16**, as depicted in **FIG. 1**.

[0037] An optical fiber **50** extends from a remote location, such as the earth's surface or another location in the well, to an energy converter **52**. Light energy transmitted through the optical fiber **50** is converted to heat in a substrate **54** by the converter **52**. For example, the converter **52** may be a black body interface, or another type of converter.

[0038] However, it should be clearly understood that an interface between the optical fiber **50** and the substrate **54** is not necessarily a black body or any type of separate converter **52**. Instead, the optical fiber **50** could be connected directly to the substrate **54** (as depicted for the sensing device **120** in **FIG. 8**). Other connection or interface methods may also be used in keeping with the principles of the invention, for example, the substrate **54** could have a coating integrally formed therewith, etc.

[0039] Heat produced at the converter **52** is used to increase the temperature of the substrate **54**, which in turn heats a coating **56** on an exterior side of the substrate. The converter **52** could be a special black surface on the coating **56**, or the converter could be a structure interposed between the optical fiber **50** and the substrate **54**. The heated coating **56**, in turn, heats the fluid **46**, which enables at least one property of the fluid to be detected, as described in more detail below.

[0040] As used herein, the term "coating" is used to indicate an outer layer or region of material, and is not used to specify any particular technique of producing such a layer or region. Coatings may be produced by any process, such as heat treatment, chemical treatment, application of a different material to a substrate, etc.

[0041] In order for the heat produced at the converter **52** to be transmitted efficiently to the fluid **46**, the substrate **54** and coating **56** are preferably made of highly thermally conductive materials and are insulated from the tubular string **42** by insulation **58**. However, if the tubular string **42** is made of a low thermal conductivity material, such as a composite material, or in other circumstances, the insulation **58** may not be used.

[0042] The substrate **54** may be made of a metallic material, such as steel. The coating **56** is preferably made of a material which is very durable, relatively erosion resistant, relatively hard, as well as being highly thermally conductive, since it is exposed to the flow of the fluid **46**. A material suitable for use in the coating **56** is a diamond material. The diamond material is preferably attached to the substrate **54** by chemical vapor deposition, since this results in a reproducible uniform thickness of the diamond material which is permanently bonded to the substrate **54**.

[0043] It should be understood, however, that other materials may be used for the substrate **54** and coating **56**, if desired. In fact, it is not necessary for the substrate **54** material and the coating **56** material to be different materials. Thus, it is not necessary for the sensing device **40** to include a separate substrate **54** (for example, as depicted for the sensing device **120** in **FIG. 8**).

[0044] As the fluid **46** flows past the surface **44**, the fluid is heated as described above. A temperature sensor **60**, such as a thermocouple or a fiber optic temperature sensor (for example, a Bragg grating-type sensor), detects the temperature of the coating **56**. Due to the high thermal conductivity of the coating **56**, the fluid **46** in direct contact with the surface **44** should reach approximately the same temperature as the coating, but if a more direct measurement of the fluid temperature proximate the surface is desired, the sensor **60** may be positioned so that it is in direct contact with the fluid.

[0045] Another temperature sensor **62** is positioned downstream from the surface **44**, and yet another temperature sensor **64** is positioned upstream from the surface. The sensors **60, 62, 64** are depicted in **FIG. 2** as being connected to a single fiber optic line **68** extending to a remote location, such as to the instrument at a remote location as discussed above. However, separate lines may be used for the individual sensors **60, 62, 64**, and other types of lines (such as electrical lines), power supply and communications may be used, without departing from the principles of the invention.

[0046] It should be understood that it is not necessary for all of the temperature sensors **60, 62, 64** to be included in the fiber optic sensing device **40**, but the use of these temperature sensors does permit a significant number of properties of the fluid **46** to be detected. For example, use of the temperature sensors **62, 64** upstream and downstream of the surface **44** permits the direction of flow of the fluid **46** to be determined. The fluid **46** will have an increased temperature on the downstream side of the surface **44**. As depicted in **FIG. 2**, the temperature sensor **62** will detect an increased

temperature of the fluid **46**, whereas the sensor **64** will not. If the flow of the fluid **46** were reversed, the sensor **64** would detect the increased temperature of the fluid **46**.

[0047] If a known, controlled, constant intensity of light energy is transmitted through the optical fiber **50**, the coating **56** will eventually reach an elevated equilibrium temperature, detected by the sensor **60**. This equilibrium temperature is related to the velocity of the flow (or flow rate) of the fluid **46** past the surface **44**, as well as being related to other properties of the fluid. Thus, if the light energy intensity and the coating **56** temperature are known, the fluid **46** flow rate may be determined.

[0048] The other properties of the fluid **46** may be determined by utilization of the sensing device **40**, as well. For example, the sensors **60**, **64** may be used to determine the density and thermal characteristics of the fluid **46**. By detecting (via the sensor **60**) the heat energy transmitted to the fluid **46** proximate the surface **44**, as compared to the ambient conditions sensed at the upstream sensor **64**, the thermal conductivity of the fluid may be determined.

[0049] By detecting the difference between the temperature of the fluid **46** proximate the surface **44** and the temperature of the fluid at the upstream sensor **64**, the density of the fluid may be determined. This temperature difference may also be used to determine the velocity of the fluid **46**. If the density of the fluid **46** is determined, then the relative ratio of different liquids (e.g., oil/water) making up the fluid may be determined. Of course, the downstream sensor **62** may be used in place of the upstream sensor **64** in these determinations of thermal conductivity, velocity, composition, etc., when flow direction is reversed.

[0050] Those skilled in the art will recognize that such determinations of density, velocity, identity, composition, etc. depend on known fluid mechanics and heat transfer relationships. Calculations of these properties may require reasonable assumptions to be made and/or measurement of additional variables, etc., to make accurate determinations.

[0051] An alternate technique would be to vary the intensity of the light energy transmitted through the optical fiber **50**. For example, a fiber laser **66** interconnected to the optical fiber **50** may be cycled on and off. The laser **66** may be positioned downhole as depicted in **FIG. 2**, or it may be positioned at a remote location, such as the earth's surface. Of course, another type of light energy source or laser may be used instead of, or in addition to, the laser **66**.

[0052] When the laser **66** is on, the coating **56** will reach an elevated equilibrium temperature. When the laser **66** is off, the coating **56** temperature will reduce to another equilibrium temperature. By detecting multiple sets of these elevated and reduced equilibrium temperatures, more accurate determinations may be made as to the properties of the fluid **46**.

[0053] As another alternative, the coating **56** may be heated to an elevated equilibrium temperature by turning the laser **66** on. Then, with the laser **66** turned off, the transient decline in temperature of the coating **56** over time is detected by the sensor **60**. This cooling versus time data may then be used in determining the velocity, density, composition, etc. of the fluid **46**.

[0054] A transient increase in temperature of the coating **56** over time could also be used. Transient cooling and/or

heating measurements could be combined with steady state measurements for enhanced accuracy in the fluid property analysis.

[0055] Referring additionally now to **FIG. 3**, a method **70** embodying principles of the invention is representatively illustrated with steps of the method in flowchart form. The method **70** has been described in part above in conjunction with the description of the sensing device **40**. However, it should be understood that the method **70** may be used with other sensing devices without departing from the principles of the invention.

[0056] In step **72** of the method **70**, a sensor surface is placed in contact with a fluid. The fluid may be the fluid **46** of **FIG. 2**, fluid in the annulus **32** of **FIG. 1**, fluid in the cement **18**, fluid in the formation **14**, etc. Alternatively, the sensor surface may be placed in contact with another substance, such as the tubular string **20** material, the casing **16** material, the cement **18**, the formation **14**, etc.

[0057] In step **74**, the sensor surface is heated. As described above for the sensing device **40**, light energy transmitted through the optical fiber **50** may be converted to heat energy to heat the sensor surface **44**. By heating the sensor surface, the substance in contact with the sensor surface is also heated.

[0058] The light energy transmitted through the optical fiber **50** may be varied to produce variations in the response of the substance to the heating produced by the light energy. The response of the substance to this varied heating is indicative of properties of the substance, such as density, thermal conductivity, velocity, phase, composition (oil/water ratio, ratio of fluids produced from multiple zones), identity (zone of origin), the presence and/or progress of a fracture in a formation, a fluid interface in a formation (see **FIG. 1**) or in a well (see **FIG. 4**), integrity of a cementing operation (density of cement, presence of voids and cracks, migration of fluid through cement), etc.

[0059] The response may be qualitative or indicative of a trend over time. When combined with other data or modeling, the response may produce qualitative and quantitative results on which to base decisions concerning, for example, how production from the well or an injection program should be adjusted, etc.

[0060] The intensity of the light energy transmitted through the optical fiber **50** may be maintained constant, for example, to produce an equilibrium temperature of the coating **56** and/or of the substance in contact with the surface **44**. For a given intensity of light energy transmitted through the optical fiber **50**, the corresponding equilibrium temperature of the coating **56** and/or of the substance in contact with the surface **44** is indicative of properties of the substance, such as those discussed above. Multiple equilibrium temperatures for corresponding multiple light energy intensities may be obtained to increase the accuracy of the determination of properties of the substance.

[0061] Equilibrium temperatures in the coating **56** or substance may be produced by other methods, such as by varying the light energy in patterns or waves (square waves, sine waves, etc.). Multiple temperature equilibria may also be produced by maintaining the light energy constant and varying a fluid property, for example, by adjusting the flow rate using a choke, etc.

[0062] The light energy transmitted through the optical fiber **50** may be at times varied or cycled, and at times maintained constant. It is conceived that a combination of techniques will produce reliable “signatures” of the substance properties, so that they may be readily determined given the wealth of information provided by the sensing device **40**. Obtaining these substance property “signatures” is an example of the type of empirical testing that a person skilled in the art would use to employ a new sensing device in a particular application. For example, production log measurements may be used to calibrate the “signatures,” thereby eliminating, or at least reducing, the need to periodically run production logs.

[0063] For good heat transfer to the substance in contact with the sensor surface **44**, a substrate **54** and chemical vapor deposited diamond material coating **56** have been described above. The diamond material in particular has a very high thermal conductivity and is very durable. However, it should be understood that the invention is not limited to use of any particular material or configuration of the structure used to transfer heat to the substance in contact with the surface **44**.

[0064] In step **76** of the method **70**, temperature is sensed. This may be the temperature of the substance in contact with the sensor surface, the temperature of the substance remote from the sensor surface, the temperature of the sensor surface, temperature change over time in the substance or sensor surface, or another temperature or combination of temperatures. Preferably, the sensed temperature(s) is indicative of a property of the substance in contact with the sensor surface, as discussed above.

[0065] Although certain types of temperature sensors have been described above, it should be understood that any type of sensor may be utilized to directly or indirectly detect a temperature in the sensing device **40**. It is also conceived that the sensors may be positioned in any orientation or arrangement relative to the sensor surface **44** as may be determined to be appropriate for sensing a particular substance property. This is another example of the versatility of the sensing device **40**, in that it may be configured as best suits the application.

[0066] In step **78**, properties of the fluid or other substance are calculated using the sensed temperature(s) from step **76**. A person of ordinary skill in the art, given the appropriate information (e.g., the configuration of the sensing device, well parameters, energy transmission, temperature data, etc.) will be able to determine the desired properties of the substance without undue experimentation. It should, however, be recognized that, for some of the substance properties to be calculated, some empirical parameters may need to be determined through controlled tests before accurate calculations may be made, the sensing device **40** configured and calibrated, etc.

[0067] Referring additionally now to **FIG. 4**, another fiber optic sensing system **80** is representatively and schematically illustrated. The sensing system **80** is similar in many respects to the sensing system **10** of **FIG. 1**, in that multiple sensing devices **40** are attached to a tubular member or string **82**. In the sensing system **80**, the sensing devices **40** are used to detect properties of fluids (indicated by arrows **84**, **86**) flowing through the tubular **82**.

[0068] An interface **88** between the fluids **84**, **86** may be detected by the sensing devices **40** which are circumferen-

tially distributed about the tubular **82**. The upper sensing devices **40** will detect one or more properties of the fluid **84** above the interface **88**, and the lower sensing devices will detect one or more properties of the fluid **86** below the interface. This information may be useful where the tubular **82** is positioned in an at least substantially horizontal wellbore and the fluids **84**, **86** are oil and water, or gas and oil, etc.

[0069] If the tubular **82** is not horizontal, a longitudinal location of the interface **88** may be determined using the sensing devices **40** which are distributed longitudinally on the tubular. These sensing devices **40** may also, or alternatively, be used to determine properties of the tubular **82** and/or the fluids **84**, **86**, such as thermal gradient along the tubular, thermal conductivity, density, heat transfer coefficient, heat capacity, etc.

[0070] Referring additionally now to **FIG. 5**, another sensing device **90** is representatively and schematically illustrated. The sensing device **90** is very similar to the sensing device **40** described above, and so elements of the sensing device **90** which are similar to those previously described are indicated in **FIG. 5** using the same reference numbers.

[0071] As depicted in **FIG. 5**, the sensing device **90** is separated from any structure on which it may be mounted, for clarity of illustration and description, and to emphasize that it is not necessary for any sensing device described herein to be attached to any particular structure, or any structure at all. For example, the sensing device **90** could be installed prior to cementing or flowed into the well with the cement **18** as shown for the sensor **30** in **FIG. 1**.

[0072] The sensing device **90** as depicted in **FIG. 5** also does not have temperature sensors. It is not necessary for any sensing device described herein to have one or more temperature sensors in any particular configuration or arrangement relative to the surface **44**. However, the sensing device **90** does preferably include at least one temperature sensor, which is not illustrated in **FIG. 5**.

[0073] The sensing device **90** does differ in at least one substantial respect from the sensing device **40**, in that the optical fiber **50** extends to the converter **52**, which is positioned adjacent the coating **56**. This configuration may produce a more direct heating of the surface **44**. The increased heating efficiency of the sensing device **90** may be desirable for use in some methods, such as the method **100** representatively illustrated in flowchart form in **FIG. 6**.

[0074] The method **100** is similar in many respects to the method **70** described above, and so steps of the method **100** which are similar to those previously described are indicated in **FIG. 6** using the same reference numbers. In particular, steps **72**, **74** and **78** are used in the method **100**, for example, a substance in contact with the sensor surface **44** is subjected to a heat transfer detected by the sensing device **40**, which is used to determine one or more properties of the substance.

[0075] However, in the method **100**, a step **102** is used wherein a phase of the substance is changed. In many applications the substance of interest proximate to the sensor surface **44** is a fluid being produced from a formation. Under downhole conditions the fluid is often predominately a liquid phase (e.g., oil and/or water), and often includes a complex mixture of hydrocarbons, including dissolved gases

and/or hydrocarbon fractions, which are liquid under down-hole pressure, but at some combination of reduced pressure and/or increased temperature becomes gaseous. The heating of the sensor surface **44** and the fluid immediately proximate can, therefore, cause an evolution of gas from the liquid, i.e., a local phase change.

[0076] If the substance is initially a fluid, such as oil with gas dissolved therein, the heat transfer from the sensor surface **44** to the liquid causes a phase change, wherein the gas “bubbles” out of the liquid oil. This phase change (known as the “bubble point”) is detected by the sensors in the sensing device **40** in step **104** of the method **100**.

[0077] For example, one or more of the temperature sensors **60**, **62**, **64** may detect the change in heat transfer accompanying the phase change as the equilibrium temperature changes dramatically. Further, the sensing device **40** may include a pressure sensor **106** which detects the ambient hydrostatic or circulating pressure proximate the sensor surface **44**. The pressure sensor **106** may be a fiber optic sensor (such as a fiber Bragg grating-type sensor), in which case an optical fiber **108** may extend to the sensor from a remote location.

[0078] This information may be used to determine the PVT (pressure/volume/temperature) characteristics of the fluid **46**. Of course, the phase change may be reversed, performed multiple times, be between other phases (such as liquid/solid as in hardening cement, solid/liquid as in chemical treatment of paraffin accumulation), etc., in keeping with the principles of the invention. Wellbore fluids may be separately analyzed, for example, at a suitably equipped commercial laboratory, to precisely determine the PVT characteristics, and then this laboratory analysis may be used to calibrate the sensor measurements. Qualitative measurements may also be used, for example, to identify trends in the PVT characteristics over time.

[0079] Referring additionally now to **FIG. 7**, another method **110** embodying principles of the invention is representatively illustrated. The method **110** is very similar to the method **70** of **FIG. 3**. One significant difference is that, in step **112** of the method **110**, a structure (not necessarily a fluid) is in contact with the sensor surface **44**, and it is desired to monitor properties of the structure over time. The sensor surface is heated in step **114**, temperature is sensed in step **116**, properties of the structure are calculated in step **118**, and the method **110** is repeated periodically in step **120**.

[0080] In the above description of the method **70**, the step **72** was described as possibly being performed with the sensor surface **44** in contact with another substance, such as the tubular string **20** material, the casing **16** material, the cement **18**, the formation **14**, etc. The method **70** demonstrates how this may be accomplished for a particular application in which it is desired to monitor properties of a structure over time.

[0081] For example, it may be desired to monitor a physical property, such as stress or strain, or a thermal property of the tubular string **20** over an extended period. In **FIG. 1**, element **37** indicates a particular location which can be considered as a local thermal system of interest, wherein sensor **26** is used to detect the thermal properties of this thermal system which includes the formation **14**, cement **18**, casing **16**, annulus **32**, tubing **20**, the proximate trapped and

flowing fluids, and the associated thermal interfaces. The steps **112-118** could be performed each day, week or month, etc., to give an indication of how these properties change over time.

[0082] Another example would be placing the sensor surface **44** in contact with the formation **14** in order to detect properties of fluids in the formation. By monitoring the fluid properties in the formation **14** over time, the presence and progress of the fluid interface **34** through the formation, or other useful information, may be determined.

[0083] The steps **112-118** are very similar to the corresponding steps **72-78** of the method **70**. The descriptions and variations of these corresponding steps **72-78** apply to the steps **112-118** of the method **110**, with the exception that the method **110** is more applicable to use with structures experiencing change in a well. For example, the method **110** may be used to calculate heat transfer through a structure, cement integrity (presence of voids and cracks, bond quality), fluid migration through cement or the formation, reservoir evaluation, heat capacities, other thermal properties of multiple structures and/or fluids downhole, physical properties of tubulars or other structures or fluids downhole, etc.

[0084] Referring additionally now to **FIG. 8**, another sensing device **120** embodying principles of the invention is representatively and schematically illustrated. The sensing device **120** is at an enlarged scale and is depicted apart from its supporting structure and any associated sensors for illustrative clarity. However, it should be understood that the sensing device **120** may be positioned and supported in any manner, and may include sensors, such as the temperature sensors **60**, **62**, **64**, in keeping with the principles of the invention.

[0085] Instead of heating the sensor surface **44** using light energy transmitted through the optical fiber **50** and converted to heat energy, in the sensing device **120** the light energy is transmitted directly through the diamond material **56** (or other light transmitting material, e.g., another transparent or at least translucent material) to the fluid **46** (or other substance) in contact with the surface **44**. The fluid **46** responds to this energy input, and the response is detected as an indication of one or more properties of the fluid. Of course, the sensor surface **44** could be placed in contact with a substance other than a fluid, such as a tubular string material, cement, a formation, etc., in which case a property of that substance (and possibly a fluid therein) may be determined using the sensing device **120**.

[0086] In one application, the light energy transmitted through the optical fiber **50**, and thence through the diamond material **56**, is reflected off of the fluid **46** (or other substance) back through the diamond material to the optical fiber. The reflected light is transmitted through the optical fiber **50** to a detector **122** at a remote location, such as the earth's surface or another location in the well. The reflected light may be analyzed to determine certain properties of the fluid **46**.

[0087] In another application, the light energy transmitted through the diamond material **56** to the fluid **46** may cause at least a portion of the fluid to fluoresce. This fluorescence, or lack thereof, is detected by the detector **122** (such as a fluoroscope) in order to determine the composition, identity, source, water/oil ratio, or other property of the fluid **46**.

[0088] In another application, the light energy transmitted through the diamond material **56** to the fluid **46** may excite the fluid to give off a spectrum indicative of the elemental composition of the fluid. This spectrum is detected by the detector **122** (such as a spectrometer) in order to determine the composition, identity, source, water/oil ratio, or other property of the fluid **46**.

[0089] In another application, the light energy transmitted through the diamond material **56** to the fluid **46** may heat the fluid. Such heating of the fluid **46** and/or associated heating of the diamond material **56** may be detected directly or indirectly by sensors, such as the temperature sensors **60**, **62**, **64**, to enable determination of properties of the fluid, such as density, velocity, thermal conductivity, or other property of the fluid.

[0090] Thus, the diamond material **56** may be considered as a "window" to permit the light energy transmitted through the optical fiber **50** to be also transmitted to the fluid **46** or other substance in contact with the sensor surface **44**. Note that the diamond material **56** may be formed as a coating on a substrate as described above, although **FIG. 8** shows the diamond material apart from any substrate.

[0091] Referring additionally now to **FIG. 9**, a method **130** embodying principles of the invention is representatively illustrated in flowchart form. The method **130** may be performed using the sensing device **120** of **FIG. 8**, or other sensing devices may be used in keeping with the principles of the invention. The method **130** is described herein as if a fluid is in contact with the sensor surface **44**, but it should be understood that any type of substance may be used instead of, or in addition to, a fluid.

[0092] In step **132**, the fluid **46** contacts the sensor surface **44**. In step **134**, the fluid **46** is excited by transmission of light energy from the optical fiber **50** through the sensor surface **44** to the fluid. The fluid **46** may be heated by the light energy, a portion of the fluid may fluoresce, the fluid may give off a spectrum, etc. It should be understood that any response of the fluid **46** (or other substance) to the transmission of light energy through the sensor surface **44** is within the principles of the invention.

[0093] In step **136**, the response of the fluid **46** to the light energy transmitted through the sensor surface **44** is sensed. This sensing step **136** may be performed in the well proximate the sensing device **120**, or it may be performed at a remote location. For example, a fluoroscope or spectrometer **122** could be positioned at the earth's surface to detect the response of the fluid **46**, or downhole sensors may be used, etc. In step **138**, the response to the fluid **46** is used to calculate properties of the fluid, such as thermal or physical properties.

[0094] Note that the fiber optic sensing devices **40**, **90**, **120** as described herein do not obstruct any flow passage in the well, are convenient and reliable in operation, and do not require intervention into the well to operate. However, one or more of these benefits of the invention may be eliminated, if desired. For example, one of the sensing devices **40**, **90**, **120** could be used in a wireline conveyed production logging tool, which does obstruct a flow passage and requires an intervention into the well to operate. Thus, the applications of the principles of the invention are not limited to those described above.

[0095] Of course, a person skilled in the art would, upon a careful consideration of the above description of representative embodiments of the invention, readily appreciate that many modifications, additions, substitutions, deletions, and other changes may be made to the specific embodiments, and such changes are contemplated by the principles of the present invention. Accordingly, the foregoing detailed description is to be clearly understood as being given by way of illustration and example only, the spirit and scope of the present invention being limited solely by the appended claims and their equivalents.

What is claimed is:

1. A fiber optic sensing system for sensing at least one property of a substance, the system comprising:

a sensor surface proximate the substance;

an optical fiber transmitting energy to the sensor surface; and

the energy being transmitted to the substance via the sensor surface.

2. The sensing system according to claim 1, wherein the sensor surface is formed on a relatively erosion resistant material.

3. The sensing system according to claim 1, wherein the sensor surface is formed on a highly thermally conductive material.

4. The sensing system according to claim 1, wherein the sensor surface is formed on a light transmitting material.

5. The sensing system according to claim 1, wherein the sensor surface is formed on a diamond material.

6. The sensing system according to claim 5, wherein the diamond material is a chemical vapor deposition coating on a substrate of the sensor.

7. The sensing system according to claim 1, wherein the sensor detects a response of the substance to the energy transmitted to the substance from the sensor surface.

8. The sensing system according to claim 7, wherein temperature transmitted to the substance causes a change in phase of the substance.

9. The sensing system according to claim 7, wherein the response is a change in temperature of the substance.

10. The sensing system according to claim 9, wherein the temperature of the substance is detected remote from the sensor surface.

11. The sensing system according to claim 7, wherein the response is a change in phase of the substance.

12. The sensing system according to claim 1, wherein the energy transmitted by the optical fiber is light energy, the light energy being transmitted to the substance through the sensor surface.

13. The sensing system according to claim 1, wherein an intensity of the energy transmitted by the optical fiber is varied, and wherein a transient response of the substance to the varied energy is detected to thereby sense a property of the substance.

14. A fiber optic sensing system for use in detecting at least one property of a substance or heat transfer characteristic of a location proximate to the substance in a subterranean well, the sensing system comprising:

an optical fiber for transmitting energy to a sensor surface, the sensor surface being heated when energy is transmitted by the optical fiber; and

- a first temperature sensor for detecting a temperature of the substance.
- 15.** The sensing system according to claim 14, wherein the substance is a fluid, and wherein the first temperature sensor detects a temperature of the fluid proximate the sensor surface.
- 16.** The sensing system according to claim 15, wherein the substance is a fluid, and wherein the first temperature sensor detects a temperature of the fluid remote from the sensor surface.
- 17.** The sensing system according to claim 16, wherein the first temperature sensor detects a temperature of the fluid upstream from the sensor surface.
- 18.** The sensing system according to claim 16, wherein the first temperature sensor detects a temperature of the fluid downstream from the sensor surface.
- 19.** The sensing system according to claim 14, further comprising a second temperature sensor positioned remote from the first temperature sensor.
- 20.** The sensing system according to claim 19, wherein the first temperature sensor detects the temperature of the substance proximate the sensor surface, and the second sensor detects the temperature of the substance remote from the sensor surface.
- 21.** The sensing system according to claim 20, wherein the second temperature sensor is downstream from the first temperature sensor.
- 22.** The sensing system according to claim 20, wherein the second temperature sensor is upstream from the first temperature sensor.
- 23.** The sensing system according to claim 14, further comprising an energy converter between the optical fiber and the sensor surface, the converter converting light energy transmitted by the optical fiber into heat energy in the sensor surface.
- 24.** The sensing system according to claim 23, wherein the energy converter is a black body interface.
- 25.** The sensing system according to claim 14, wherein the sensor surface is on a diamond material.
- 26.** The sensing system according to claim 25 wherein the diamond material is a chemical vapor deposition coating.
- 27.** The sensing system according to claim 14, wherein energy transmitted by the optical fiber heats a substrate on which the sensor surface is disposed.
- 28.** The sensing system according to claim 27, further comprising an energy converter between the optical fiber and the substrate, the converter converting light energy transmitted by the optical fiber into heat energy in the substrate.
- 29.** The sensing system according to claim 28, wherein the energy converter is a black body interface.
- 30.** The sensing system according to claim 27, wherein the sensor surface is on a diamond material attached to the substrate, the diamond material having greater thermal conductivity than the substrate.
- 31.** The sensing system according to claim 14, further comprising a laser transmitting the energy through the optical fiber.
- 32.** The sensing system according to claim 31, wherein the laser is positioned in the well.
- 33.** The sensing system according to claim 31, wherein the laser is positioned at the earth's surface.
- 34.** The sensing system according to claim 14, wherein the substance is a fluid within a tubular string in the well.
- 35.** The sensing system according to claim 14, wherein the substance is a fluid external to a tubular string in the well.
- 36.** The sensing system according to claim 35, wherein the fluid is disposed in an annulus between the tubular string and casing in the well.
- 37.** The sensing system according to claim 35, wherein the tubular string is casing, and wherein the fluid is formation fluid.
- 38.** The sensing system according to claim 14, wherein the substance is a hardenable material positioned in an annulus between a wellbore and casing in the well.
- 39.** The sensing system according to claim 14, wherein the substance is a formation intersected by a wellbore of the well.
- 40.** The sensing system according to claim 14, wherein the substance is a solid structure in the well.
- 41.** The sensing system according to claim 40, wherein the structure is a tubular string.
- 42.** The sensing system according to claim 14, wherein the sensing system includes multiple sensors distributed circumferentially about a tubular string in the well.
- 43.** The sensing system according to claim 14, wherein the sensing system detects a level of an interface between different fluids flowing through a tubular string in the well.
- 44.** The sensing system according to claim 14, wherein the sensing system includes multiple sensors distributed longitudinally along a tubular string in the well.
- 45.** The sensing system according to claim 14, wherein the sensing system detects a level of an interface between different fluids in a formation intersected by the well.
- 46.** The sensing system according to claim 14, wherein the substance is a hardenable material installed external to a tubular string in the well, and wherein the sensing system detects a quality of installation of the hardenable material.
- 47.** The sensing system according to claim 46, wherein the sensing system detects a presence of a fluid in the hardenable material.
- 48.** The sensing system according to claim 46, wherein the sensing system detects a presence of a void in the hardenable material.
- 49.** The sensing system according to claim 46, wherein the sensing system detects a presence of a crack in the hardenable material.
- 50.** The sensing system according to claim 14, wherein the sensing system detects a direction of flow of the substance through a tubular string in the well.
- 51.** The sensing system according to claim 14, wherein the sensing system detects a rate of flow of the substance through a tubular string in the well.
- 52.** The sensing system according to claim 14, wherein the sensing system detects a property indicative of an identity of the substance in the well.
- 53.** The sensing system according to claim 14, wherein the sensing system detects a phase change in the substance in the well.
- 54.** The sensing system according to claim 14, wherein the sensing system detects a ratio between different fluids included in the substance in the well.
- 55.** The sensing system according to claim 14, wherein the substance is a tubular string material, and wherein the sensing system detects a thermal property of the tubular string material.

56. The sensing system according to claim 14, wherein the substance is a formation, and wherein the sensing system detects a thermal property of the formation.

57. The sensing system according to claim 56, wherein the sensing system detects a thermal property of a fluid in the formation.

58. The sensing system according to claim 56, wherein the sensing system detects a location of a fluid in the formation.

59. The sensing system according to claim 56, wherein the sensing system detects a presence of a fracture in the formation.

60. The sensing system according to claim 56, wherein the sensing system detects a location of a fracture in the formation.

61. The sensing system according to claim 14, wherein the detection of the substance temperature by the sensing system is indicative of a heat transfer characteristic of a local well environment.

62. The sensing system according to claim 61, wherein the heat transfer characteristic is a heat capacity of the local well environment.

63. The sensing system according to claim 14, wherein the substance is a hardenable material positioned external to a tubular string, and wherein the sensing system detects a thermal property of the hardenable material.

64. The sensing system according to claim 14, wherein the substance is a tubular string material, and wherein the sensing system detects a thermal property of the tubular string material.

65. The sensing system according to claim 14, wherein the substance is a fluid in the well, and wherein the sensing system detects a thermal property of the fluid.

66. A fiber optic sensing system for use in detecting at least one property of a substance in a subterranean well, the sensing system comprising:

a sensor surface configured for transmitting energy to the substance in the well;

an optical fiber for transmitting light energy to the sensor surface, the light energy being transmitted from the optical fiber through the sensor surface and to the substance; and

the light energy causing a response in the substance.

67. The sensing system according to claim 66, further comprising a sensor for detecting the substance response.

68. The sensing system according to claim 67, wherein the sensor is a spectrometer.

69. The sensing system according to claim 67, wherein the sensor is a fluoroscope.

70. The sensing system according to claim 67, wherein the substance response is transmitted through the optical fiber to the sensor.

71. The sensing system according to claim 66, wherein the light energy excites the substance to give off a spectrum indicative of an elemental composition of the substance.

72. The sensing system according to claim 66, wherein the light energy causes at least a portion of the substance to fluoresce.

73. The sensing system according to claim 66, wherein the light energy heats the substance.

74. The sensing system according to claim 73, wherein the substance undergoes a phase change when the light energy heats the substance.

75. The sensing system according to claim 66, wherein the sensor surface is formed on a diamond material.

76. The sensing system according to claim 66, wherein the sensor surface is formed on a chemical vapor deposited coating.

77. The sensing system according to claim 66, further comprising a laser positioned in the well transmitting the light energy through the optical fiber.

78. The sensing system according to claim 66, further comprising a laser positioned at the earth's surface transmitting the light energy through the optical fiber.

79. The sensing system according to claim 66, wherein the substance is a fluid within a tubular string in the well.

80. The sensing system according to claim 66, wherein the substance is a fluid external to a tubular string in the well.

81. The sensing system according to claim 80, wherein the fluid is disposed in an annulus between the tubular string and casing in the well.

82. The sensing system according to claim 80, wherein the tubular string is casing, and wherein the fluid is formation fluid.

83. The sensing system according to claim 66, wherein the substance is a hardenable material positioned in an annulus between a wellbore and casing in the well.

84. The sensing system according to claim 66, wherein the substance is a formation intersected by a wellbore of the well.

85. The sensing system according to claim 66, wherein the substance is a solid structure in the well.

86. The sensing system according to claim 85, wherein the structure is a tubular string.

87. The sensing system according to claim 66, wherein the sensing system includes multiple sensing devices distributed circumferentially about a tubular string in the well.

88. The sensing system according to claim 66, wherein the sensing system detects a level of an interface between different fluids flowing through a tubular string in the well.

89. The sensing system according to claim 66, wherein the sensing system includes multiple sensing devices distributed longitudinally along a tubular string in the well.

90. The sensing system according to claim 66, wherein the sensing system detects a level of an interface between different fluids in a formation intersected by the well.

91. The sensing system according to claim 66, wherein the substance is a hardenable material installed external to a tubular string in the well, and wherein the sensing system detects a quality of installation of the hardenable material.

92. The sensing system according to claim 91, wherein the sensing system detects a presence of a fluid in the hardenable material.

93. The sensing system according to claim 91, wherein the sensing system detects a presence of a void in the hardenable material.

94. The sensing system according to claim 91, wherein the sensing system detects a presence of a crack in the hardenable material.

95. The sensing system according to claim 66, wherein the sensing system detects a direction of flow of the substance through a tubular string in the well.

96. The sensing system according to claim 66, wherein the sensing system detects a rate of flow of the substance through a tubular string in the well.

97. The sensing system according to claim 66, wherein the sensing system detects an identity of the substance in the well.

98. The sensing system according to claim 66, wherein the sensing system detects a chemical composition of the substance in the well.

99. The sensing system according to claim 66, wherein the sensing system detects a phase change in the substance in the well.

100. The sensing system according to claim 66, wherein the sensing system detects fluorescence of the substance in the well.

101. The sensing system according to claim 66, wherein the sensing system detects a ratio between different fluids included in the substance in the well.

102. The sensing system according to claim 66, wherein the substance is a tubular string material, and wherein the sensing system detects a thermal property of the tubular string material.

103. The sensing system according to claim 66, wherein the substance is a formation, and wherein the sensing system detects a thermal property of the formation.

104. The sensing system according to claim 103, wherein the sensing system detects a thermal property of a fluid in the formation.

105. The sensing system according to claim 103, wherein the sensing system detects a location of a fluid in the formation.

106. The sensing system according to claim 103, wherein the sensing system detects a presence of a fracture in the formation.

107. The sensing system according to claim 103, wherein the sensing system detects a location of a fracture in the formation.

108. The sensing system according to claim 66, wherein the substance is a hardenable material positioned external to a tubular string, and wherein the sensing system detects a thermal property of the hardenable material.

109. The sensing system according to claim 66, wherein the substance is a tubular string material, and wherein the sensing system detects a thermal property of the tubular string material.

110. The sensing system according to claim 66, wherein the substance is a fluid in the well, and wherein the sensing system detects a thermal property of the fluid.

111. A method of detecting at least one property of a substance in a subterranean well, the method comprising the steps of:

positioning a sensor surface in the well proximate the substance;

transmitting energy through an optical fiber to the sensor surface, thereby heating the sensor surface and the substance proximate the sensor surface; and

detecting a temperature of at least one of the heated substance and the sensor surface.

112. The method according to claim 111, wherein the substance is a fluid flowing in the well, and wherein the detecting step is performed using a first temperature sensor positioned downstream relative to the sensor surface.

113. The method according to claim 112, further comprising the step of detecting a temperature of the heated substance using a second temperature sensor proximate the sensor surface.

114. The method according to claim 112, further comprising the step of detecting a temperature of the heated substance using a second temperature sensor upstream relative to the sensor surface.

115. The method according to claim 111, further comprising the step of forming the sensor surface on a chemical vapor deposited diamond material.

116. The method according to claim 115, further comprising the step of chemical vapor depositing the diamond material on a substrate.

117. The method according to claim 116, wherein the transmitting step further comprises heating the substrate positioned between the optical fiber and the diamond material.

118. The method according to claim 111, wherein the transmitting step further comprises varying the transmission of energy through the optical fiber, thereby producing a transient heating of the substance.

119. The method according to claim 118, wherein the energy transmission varying step further comprises varying an intensity of the energy transmitted through the optical fiber.

120. The method according to claim 118, wherein the energy transmission varying step further comprises alternately transmitting and not transmitting the energy through the optical fiber.

121. The method according to claim 111, wherein the transmitting step further comprises heating the substance, thereby causing a phase change in the substance.

122. The method according to claim 121, further comprising the step of detecting a pressure of the substance proximate the sensor.

123. A method of detecting at least one property of a substance in a subterranean well, the method comprising the steps of:

positioning a sensor surface in the well proximate the substance;

transmitting light energy through an optical fiber to the sensor surface;

transmitting the light energy through the sensor surface to the substance; and

detecting a response of the substance to the transmitted light energy.

124. The method according to claim 123, wherein the detecting step further comprises detecting the response as a temperature change in at least one of the substance and the sensor surface.

125. The method according to claim 123, wherein the detecting step further comprises detecting the response as a spectral emission from the substance.

126. The method according to claim 123, wherein the detecting step further comprises detecting the response as a fluorescence of at least a portion of the substance.

127. The method according to claim 123, further comprising the step of forming the sensor surface on a diamond material.

128. The method according to claim 127, wherein the forming step further comprises chemical vapor depositing the diamond material.

129. A method of detecting at least one property of a substance, the method comprising the steps of:

positioning a sensor surface proximate the substance;

transmitting energy through an optical fiber to the sensor surface, thereby heating the sensor surface and the substance proximate the sensor surface; and

detecting a temperature of at least one of the heated substance and the sensor surface.

130. The method according to claim 129, wherein the substance is a flowing fluid, and wherein the detecting step is performed using a first temperature sensor positioned downstream relative to the sensor surface.

131. The method according to claim 130, further comprising the step of detecting a temperature of the heated substance using a second temperature sensor proximate the sensor surface.

132. The method according to claim 130, further comprising the step of detecting a temperature of the heated substance using a second temperature sensor upstream relative to the sensor surface.

133. The method according to claim 129, further comprising the step of forming the sensor surface on a chemical vapor deposited diamond material.

134. The method according to claim 133, further comprising the step of chemical vapor depositing the diamond material on a substrate.

135. The method according to claim 134, wherein the transmitting step further comprises heating the substrate positioned between the optical fiber and the diamond material.

136. The method according to claim 129, wherein the transmitting step further comprises varying the transmission of energy through the optical fiber, thereby producing a transient heating of the substance.

137. The method according to claim 136, wherein the energy transmission varying step further comprises varying an intensity of the energy transmitted through the optical fiber.

138. The method according to claim 136, wherein the energy transmission varying step further comprises alternately transmitting and not transmitting the energy through the optical fiber.

139. The method according to claim 129, wherein the transmitting step further comprises heating the substance, thereby causing a phase change in the substance.

140. The method according to claim 139, further comprising the step of detecting a pressure of the substance proximate the sensor.

* * * * *