



US 20040244890A1

(19) **United States**

(12) **Patent Application Publication**
Cesaroni et al.

(10) **Pub. No.: US 2004/0244890 A1**

(43) **Pub. Date: Dec. 9, 2004**

(54) **OXIDIZER PACKAGE FOR PROPELLANT SYSTEM FOR ROCKETS**

Publication Classification

(76) Inventors: **Anthony Joseph Cesaroni**, Gormley (CA); **Michael J. Dennett**, Orangeville (CA); **Jeroen Louwers**, Aurora (CA)

(51) **Int. Cl.⁷ C06B 45/18**

(52) **U.S. Cl. 149/3**

Correspondence Address:
CANTOR COLBURN, LLP
55 GRIFFIN ROAD SOUTH
BLOOMFIELD, CT 06002

(57) **ABSTRACT**

(21) Appl. No.: **10/654,264**

(22) Filed: **Sep. 3, 2003**

Related U.S. Application Data

(63) Continuation of application No. 09/565,509, filed on May 5, 2000, now Pat. No. 6,647,888.

(60) Provisional application No. 60/132,795, filed on May 6, 1999. Provisional application No. 60/161,771, filed on Oct. 27, 1999.

An oxidizer package for a propellant system for a motor in which the oxidizer is separated from fuel grain, the oxidizer package comprising oxidizer material and an ignition system therefor in a wrapping or sealing material. A hybrid rocket comprising oxidizer material and fuel grain, the oxidizer material being separated from the fuel grain and being in the form of a single package or plurality of packages of oxidizer material and an ignition system therefor, said packages generally conforming to the shape of the rocket. A grid of a pyrotechnic material. A propulsion system for a hybrid rocket comprising oxidizer material in a matrix, mesh, wool, foamed metal or wires of structural or pyrotechnic material.

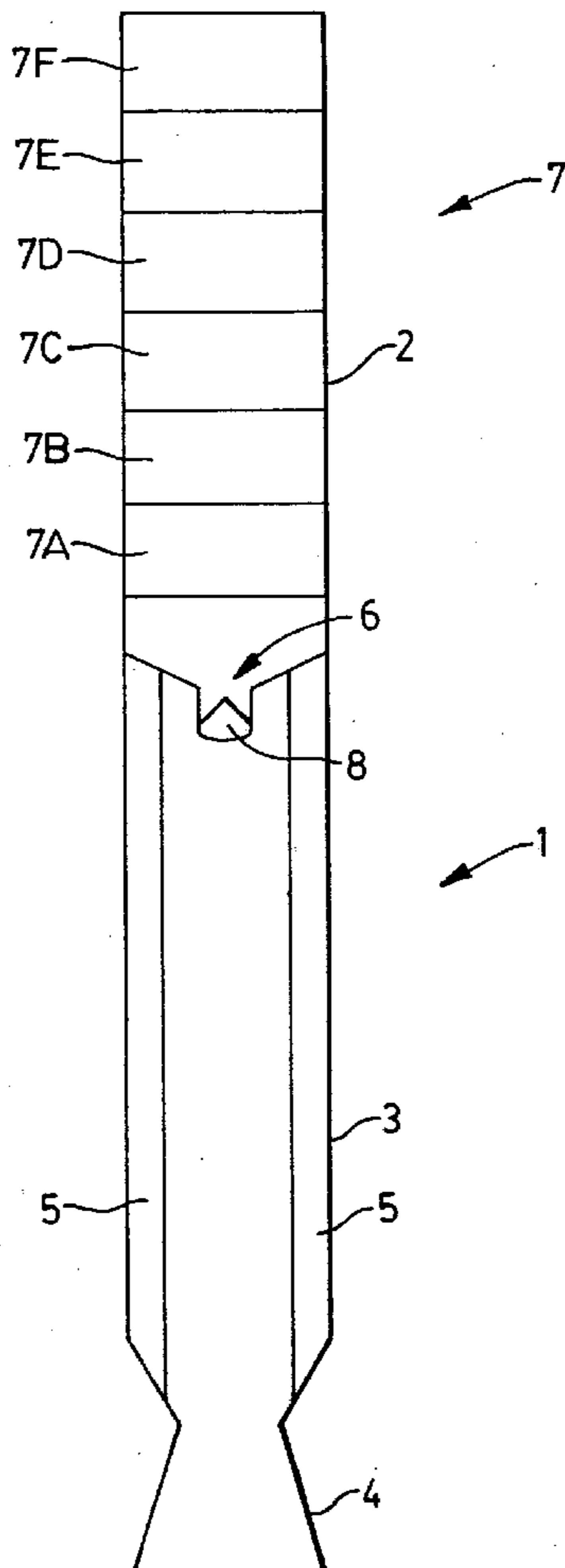

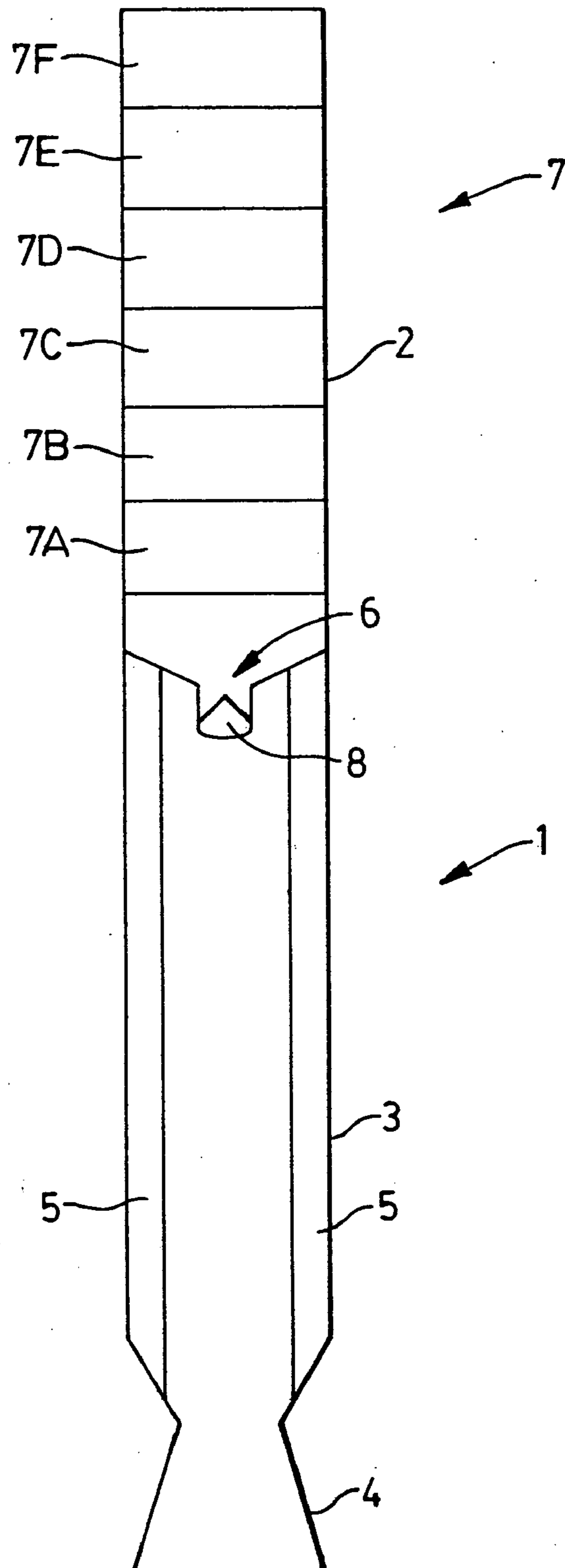

FIG. 1

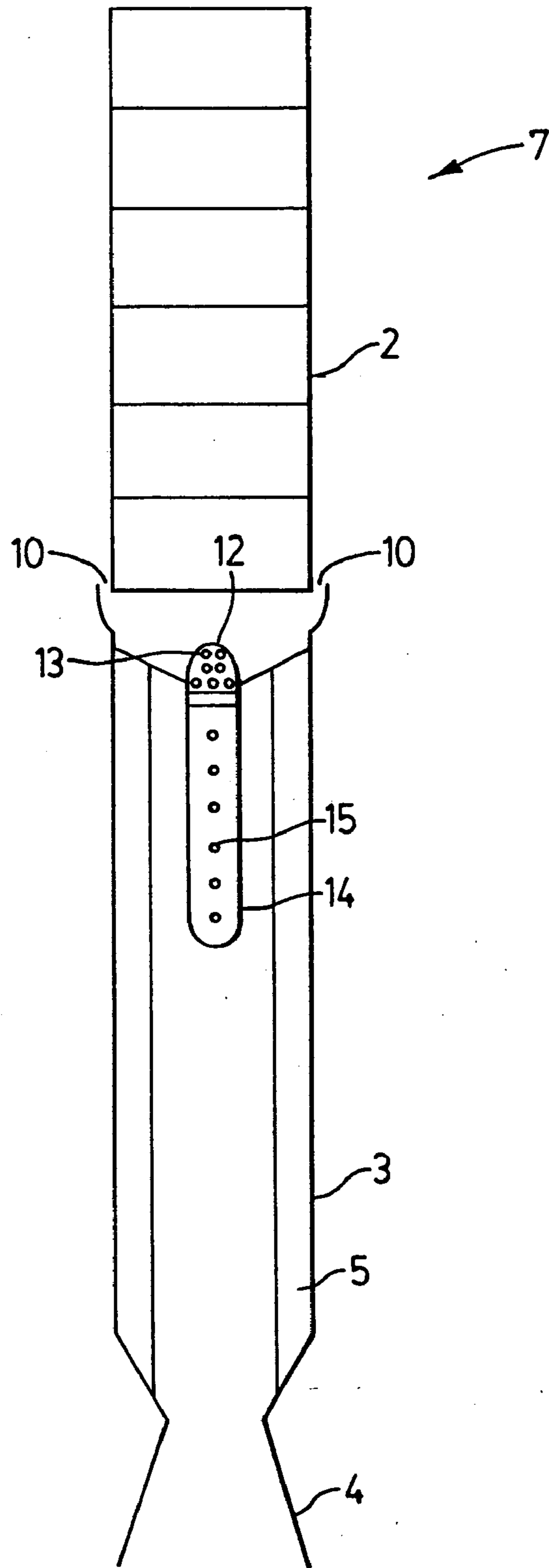

FIG. 2

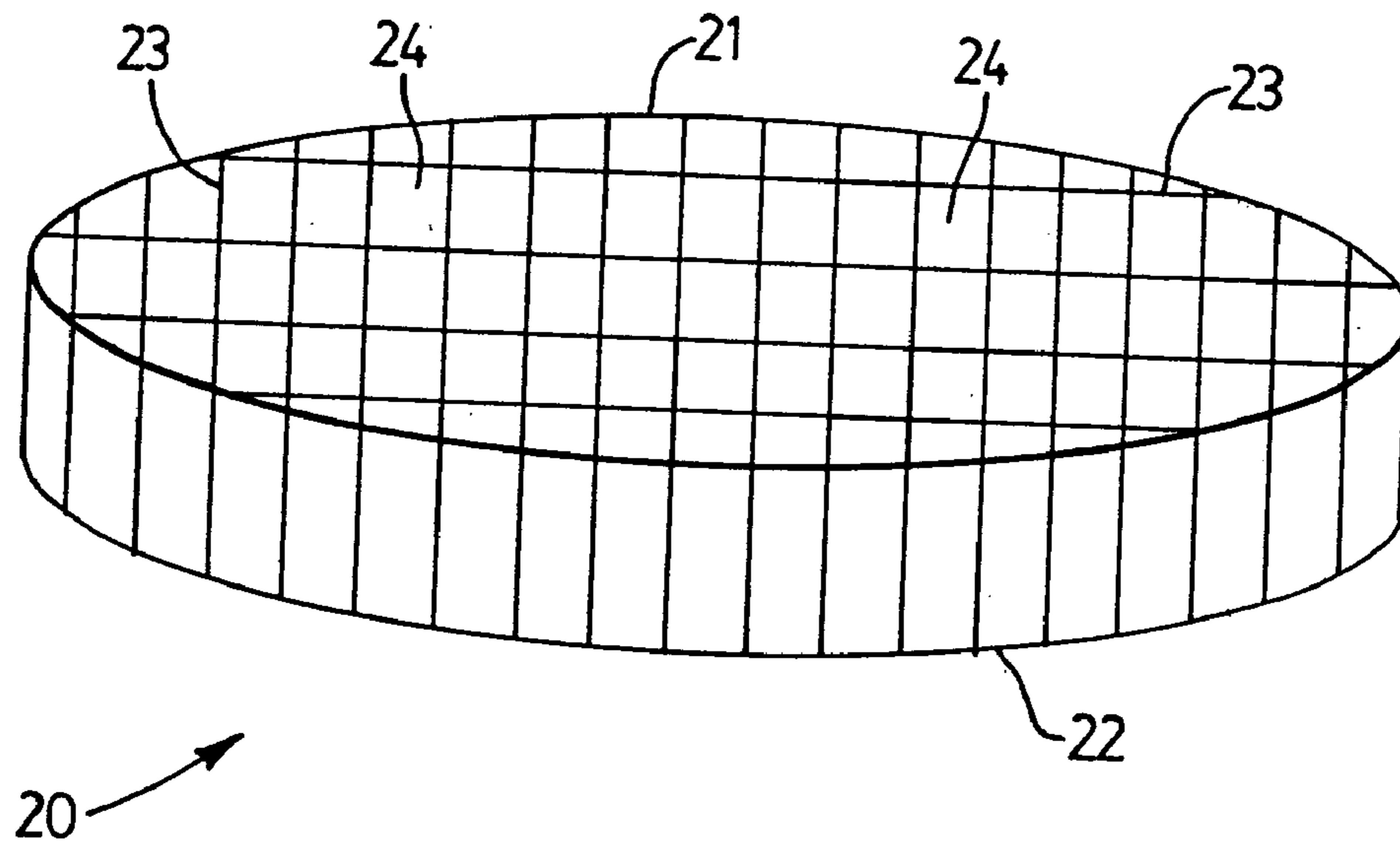

FIG. 3

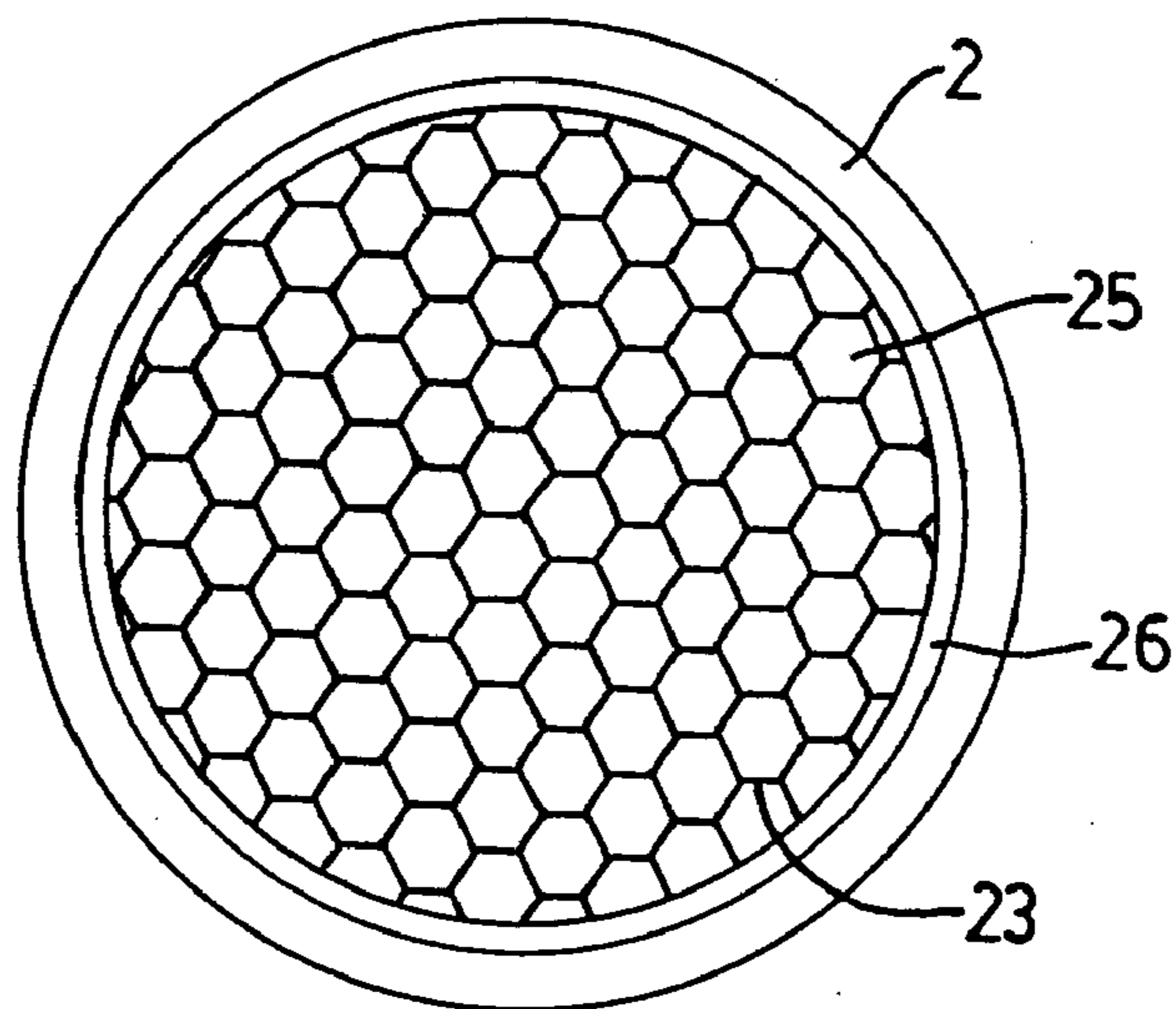

FIG. 4

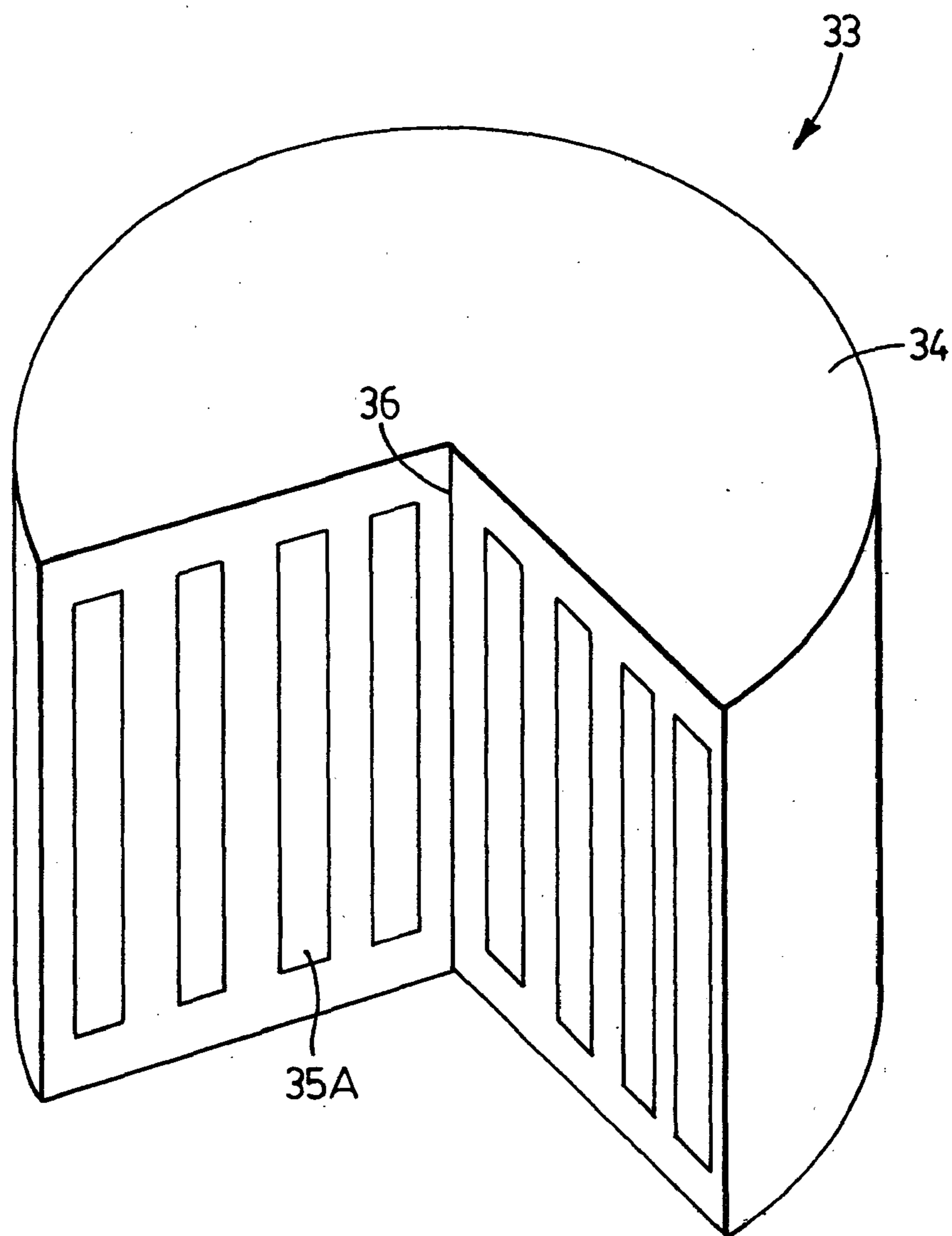

FIG. 5A

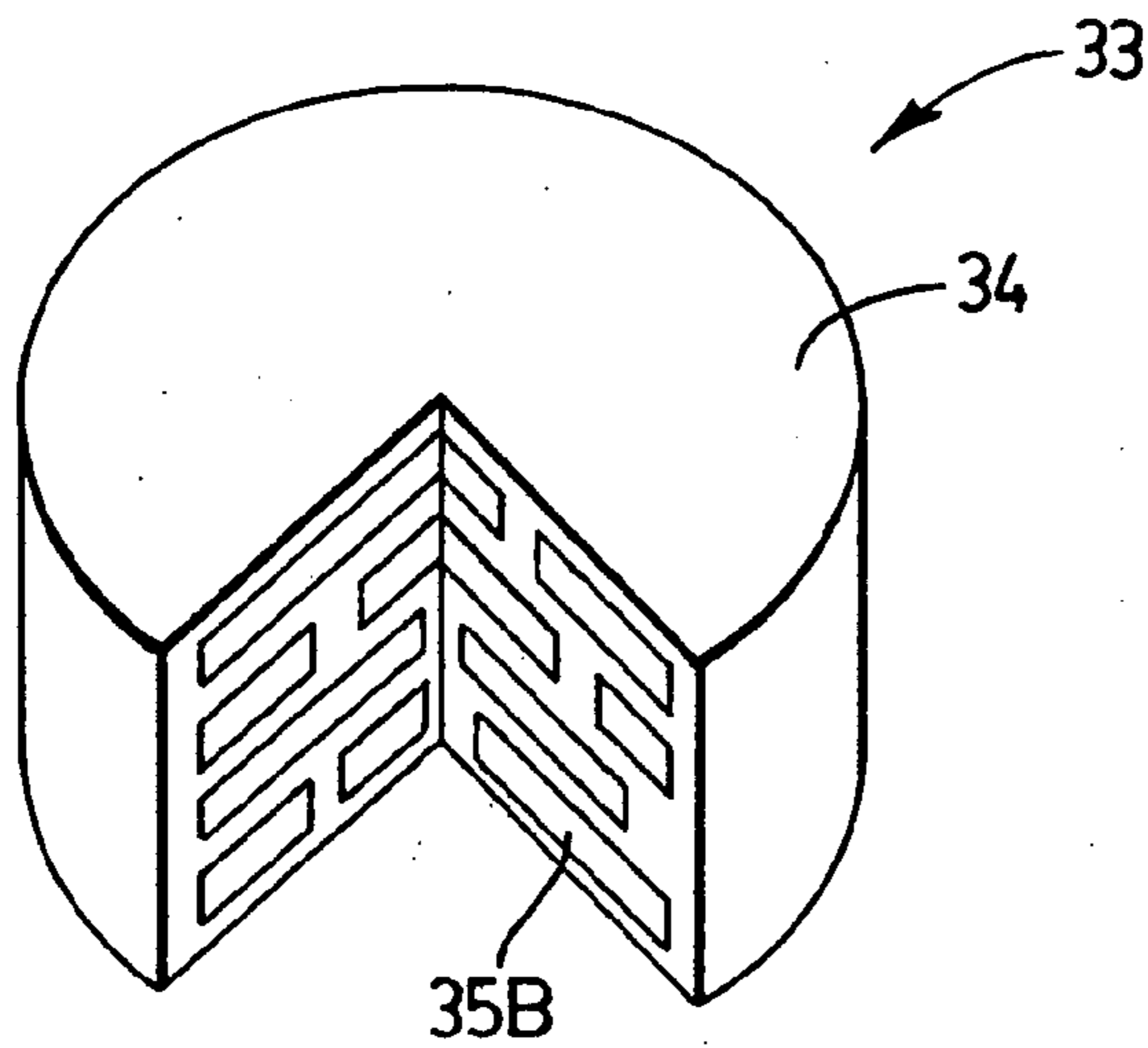

FIG. 5B

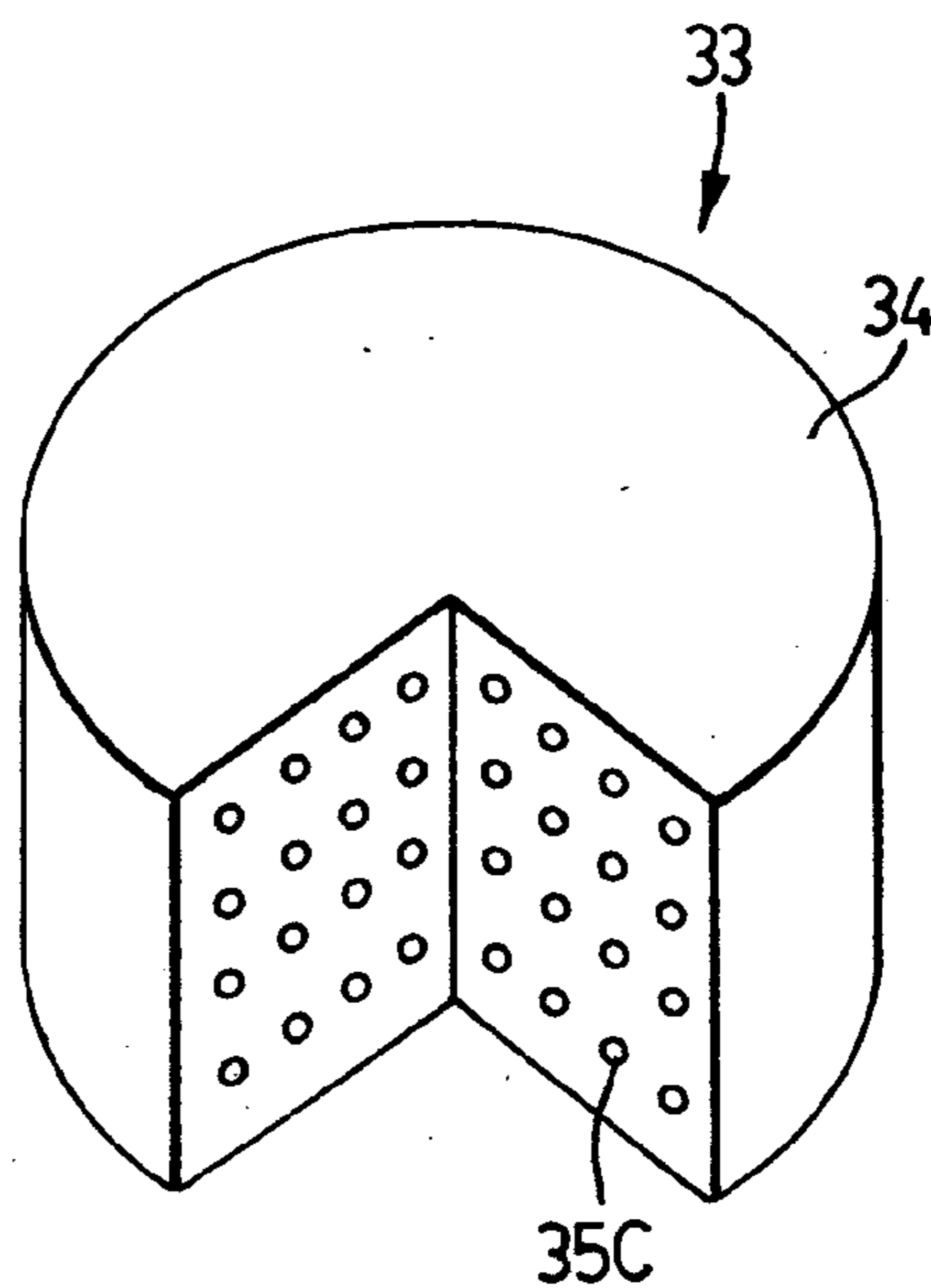

FIG. 5C

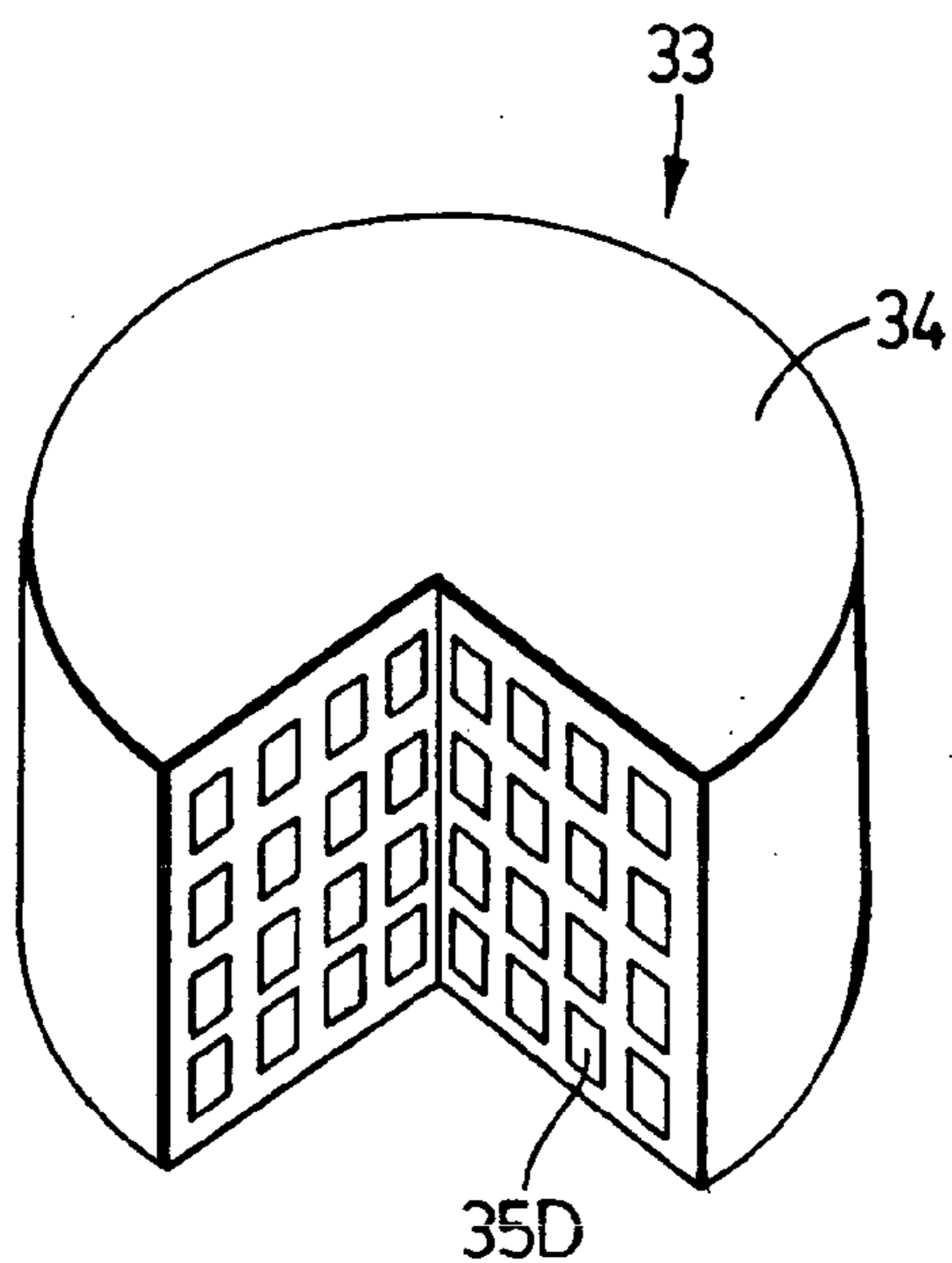
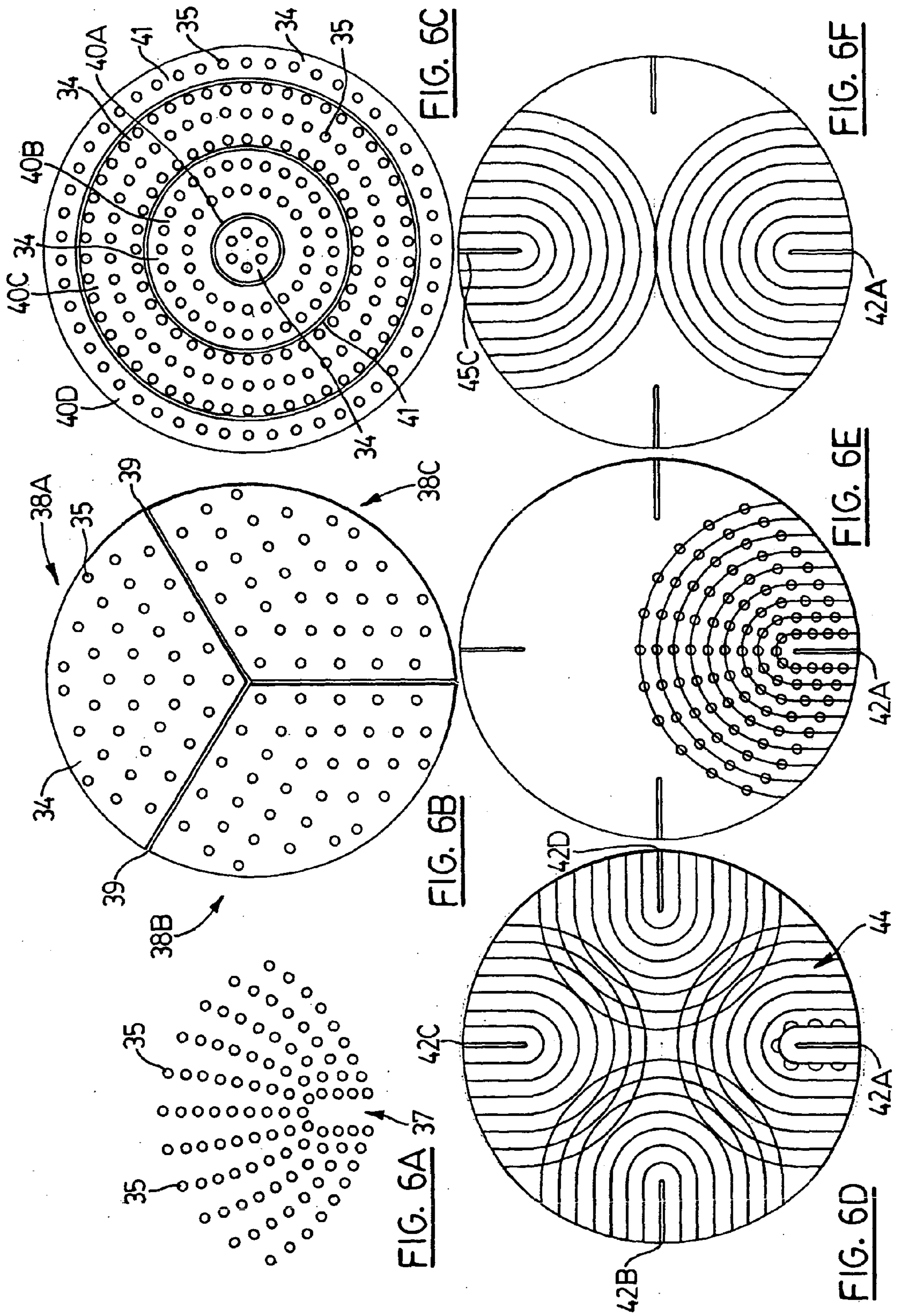

FIG. 5D



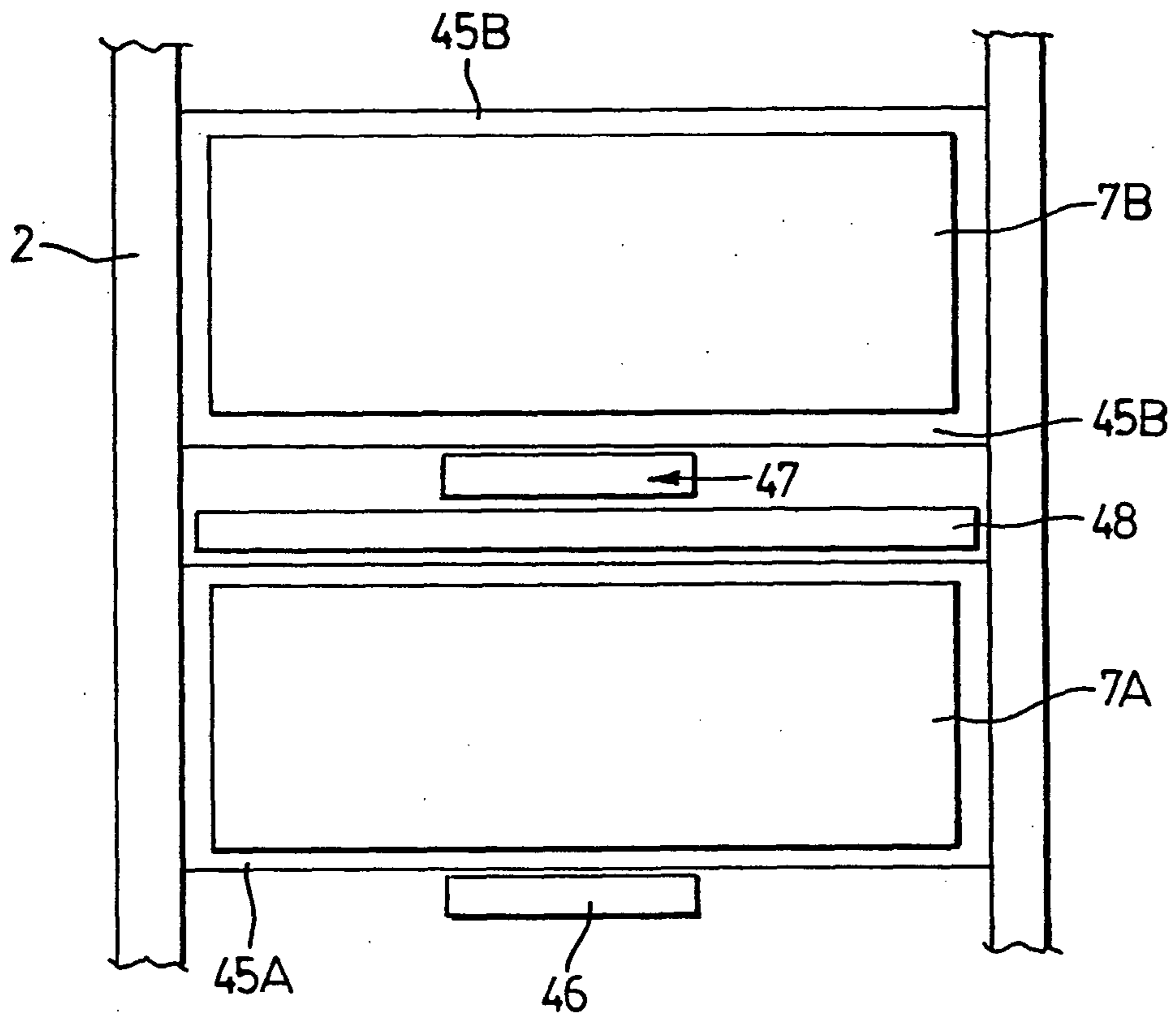

FIG. 7

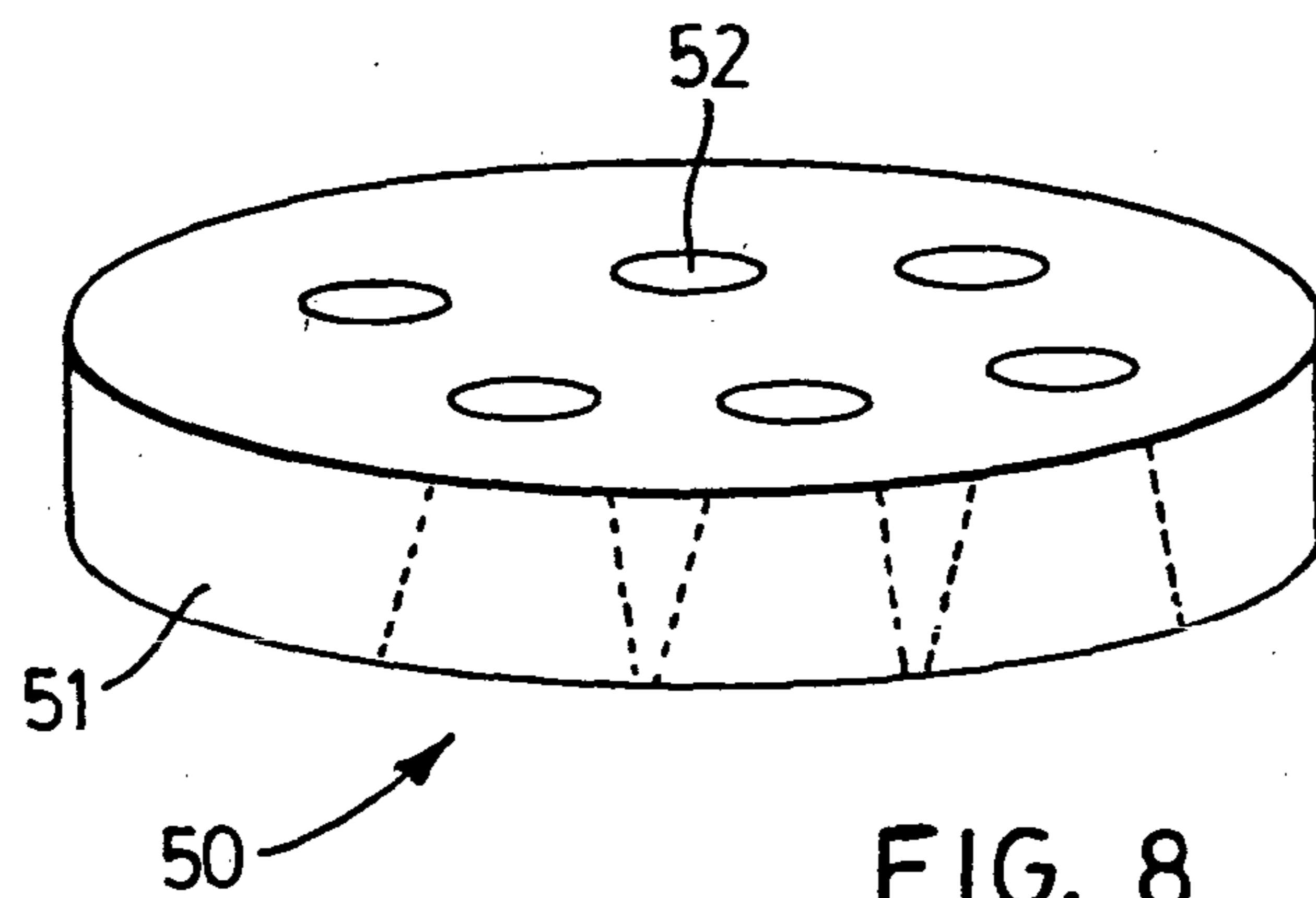

FIG. 8

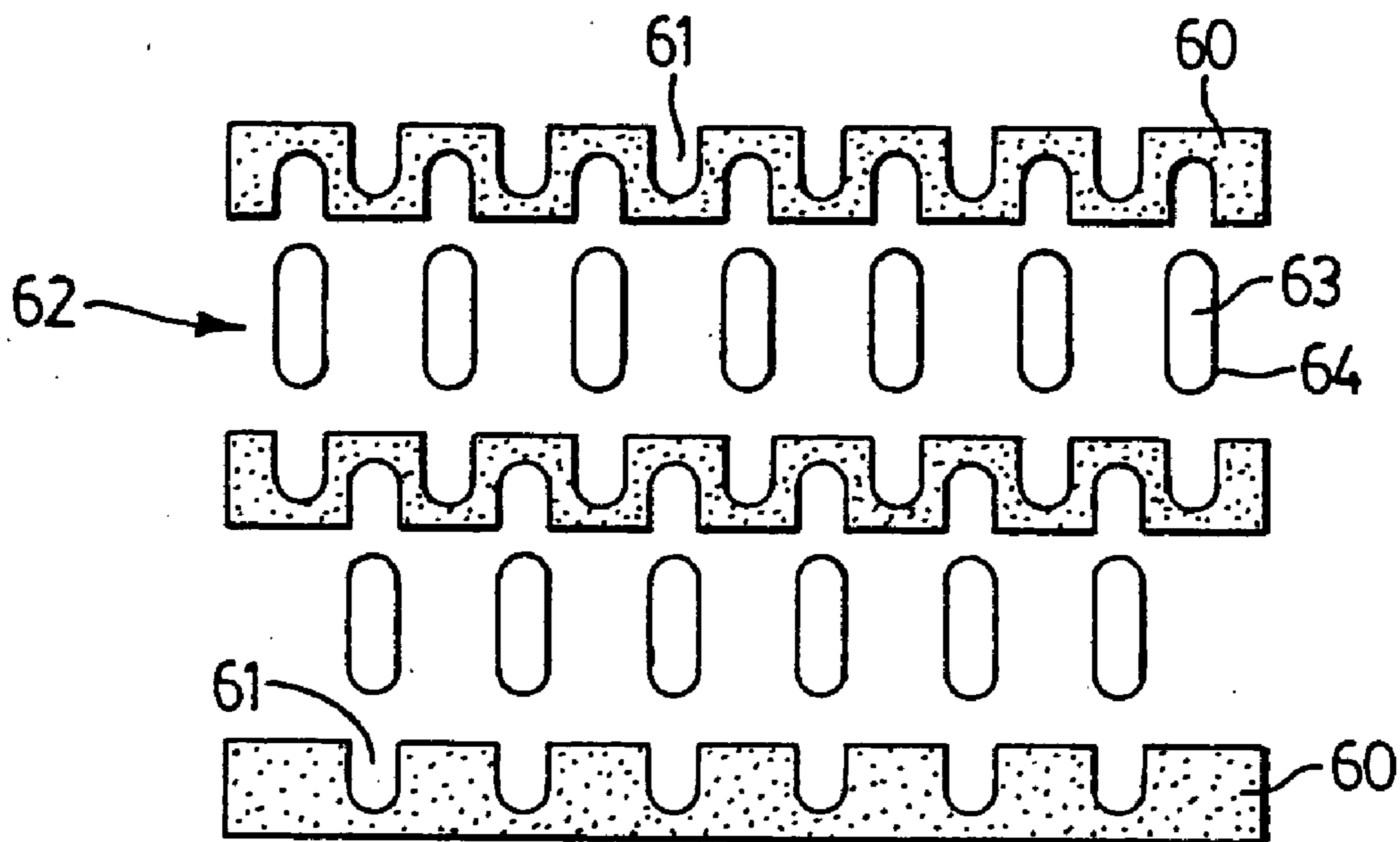

FIG. 9A

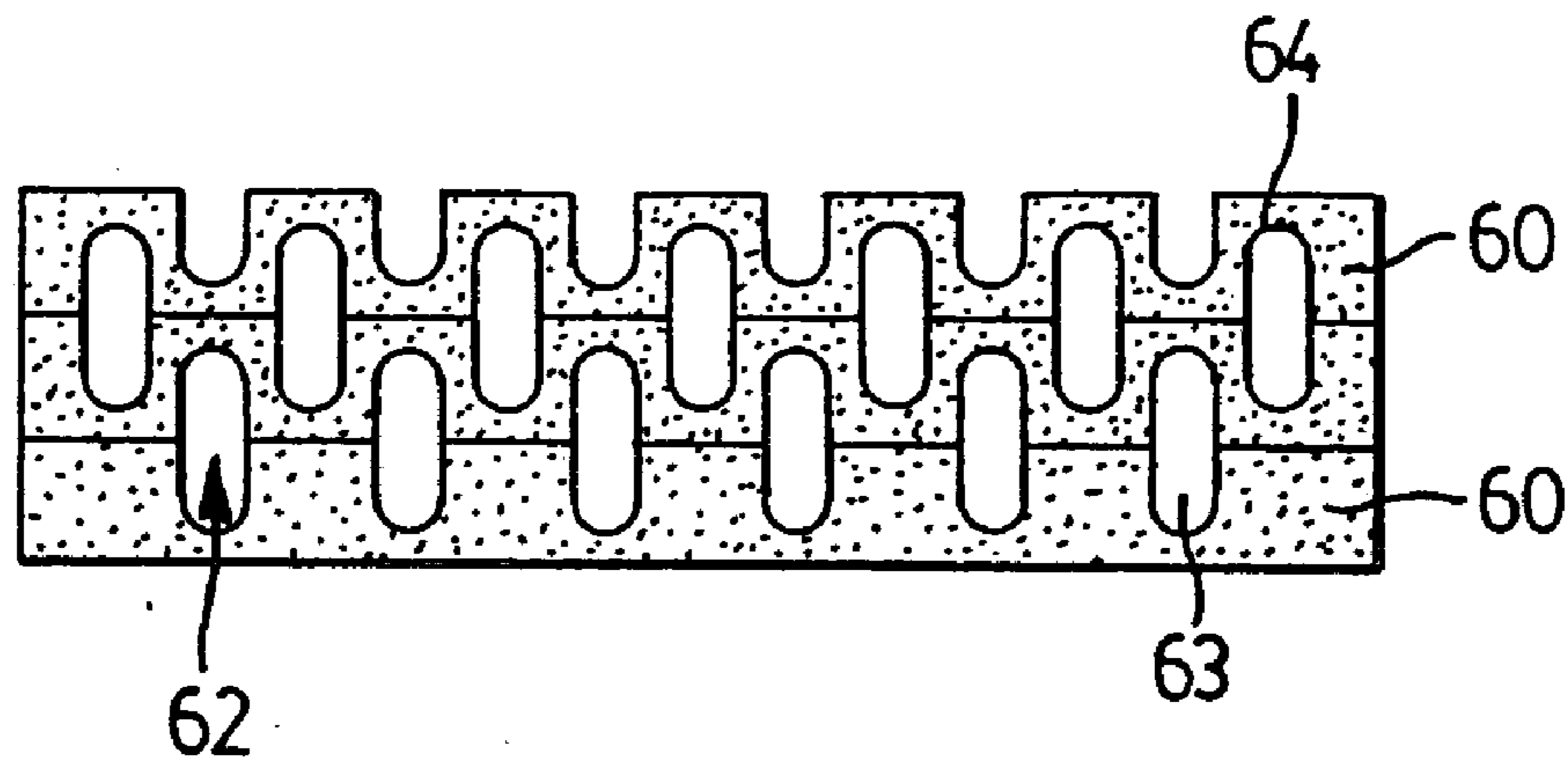

FIG. 9B

OXIDIZER PACKAGE FOR PROPELLANT SYSTEM FOR ROCKETS

CROSS REFERENCE TO RELATED APPLICATIONS

[0001] This application is a continuation of patent application Ser. No. 09/565,509, filed May 5, 2000, entitled "OXIDIZER PACKAGE FOR PROPELLANT SYSTEM FOR ROCKETS", which claims the benefit of U.S. provisional application Ser. No. 60/132,795, filed May 6, 1999, entitled "PROPELLANT SYSTEM FOR HYBRID ROCKETS", and U.S. provisional application Ser. No. 60/161,771, filed Oct. 27, 1999, entitled "OXIDIZER PACKAGE FOR PROPELLANT SYSTEM FOR ROCKETS".

FIELD OF THE INVENTION

[0002] The present invention relates to a propellant system for a hybrid rocket. In particular, the propellant system utilizes discrete packages of oxidizer capable of being stored in the oxidizer section of the hybrid rocket. In embodiments, the present invention relates to an oxidizer package for a propellant system for a rocket, in which the package contains ampoules of compounds that enhance the performance of the propellant system. In particular, the ampoules contain oxidizer. The present invention also relates to a rocket utilizing oxidizer in the form of a plurality of such packages capable of being activated or deployed in single or multiple fashion. In particular embodiments, the present invention relates to packages comprising oxidizer and an ancillary compound, in which a matrix of ancillary compound has the ampoules of oxidizer therein. The ancillary compound undergoes exothermic decomposition substantially without consumption of oxygen from the oxidizer.

BACKGROUND TO THE INVENTION

[0003] The following acronyms are used in this application:

- [0004] AP ammonium perchlorate
- [0005] AN ammonium nitrate
- [0006] ADN ammonium dinitramide
- [0007] BAMO/AMMO bis-azidomethyloxetane/azidomethyl-methoxetane copolymer
- [0008] BAMO/NMMO bis-azidomethyloxetane/nitramethyl-methoxetane copolymer
- [0009] BTTN butanetriol trinitrate
- [0010] GAP glycidyl azide polymer
- [0011] HAN hydroxylammonium nitrate
- [0012] HAP hydroxylammonium perchlorate
- [0013] HNF hydrazinium nitroformate
- [0014] HMX cyclotrimethylenetrinitramine
- [0015] HTPB hydroxyl-terminated polybutadiene
- [0016] NP nitronium perchlorate
- [0017] PBAN polybutadiene acrylonitrile
- [0018] PETN pentaerythritol tetranitrate
- [0019] TMETN trimethylolethane trinitrate

[0020] Hybrid propulsion systems offer numerous potential advantages over solid and/or liquid propulsion systems. Some potential advantages include high mass fraction, low cost, rapid deployment, reduced storage and transportation restrictions, throttling ability, configurable thrust and mission profiles as well as modifiable plume signatures and low temperature sensitivity. Traditionally, propulsion systems have used liquid oxidizers, which in many cases present handling and storage safety issues.

[0021] Solid propulsion systems could provide very high specific impulse by utilizing high performance oxidizers such as ADN, HAP, HAN, HNF, NP and the like. Many of these oxidizers offer significant gains on performance, reduced or low toxicity and have desirable exhaust signature characteristics. However, many of these oxidizers suffer from varying degrees and forms of instability, such as photo sensitivity, shock, friction and impact sensitivity, decomposition in the presence of moisture, sensitivity to pH and incompatibility (such as hypergolic reaction) to other propellant materials. A typical example of incompatibility is reaction between HNF and curing agents used in solid propellant binder systems such as HTPB and GAP. Many difficulties have been encountered incorporating the oxidizers into propellant systems, and solutions to particular storage and stability problems often result in compromising the theoretical performance potential. For example, current techniques to synthesize HNF still produce particles with length to diameter ratios of 2:1 to 3:1 with significant variation from the mean. This seriously impacts formulation rheology and can prevent achievement of optimum solids loading, as well as aggravating friction sensitivity during mixing and casting operations.

[0022] Storing the oxidizer separately in the motor offers the ability to avoid compatibility issues between these oxidizers and common solid propellant system components and to optimize the physical and environmental requirements of the oxidizer, with the potential to improve the performance of tactical missile systems. A typical example of incompatibility is reaction between HNF and curing agents used in solid propellant binder systems such as HTPB and GAP.

[0023] Separate storage of solid and semi-solid oxidizers and expulsion systems have been proposed and demonstrated in the past. Some of the difficulties in these approaches include flow stability, concentration and distribution of oxidizer solids in carrier agents, pressurization and piping system requirements, specialized control valves and system integration. Certain examples of flowable oxidizers can behave as mono-propellants causing flame tracking and catastrophic failure in the delivery and storage systems.

[0024] Rocket motors based on gaseous and liquid oxidizers have been successfully demonstrated in the past.

SUMMARY OF THE INVENTION

[0025] A propellant system for a hybrid rocket using solid or semi-solid oxidizers has now been found, including a method of storage and deployment providing structural and operational benefits. Embodiments of the invention provide a package for a propellant system for a rocket in which the package comprises oxidizer and optionally ancillary compound, the ancillary compound undergoing exothermic

decomposition substantially without consumption of oxygen from the oxidizer. The oxidizer may be in ampoules within the ancillary compound.

[0026] Accordingly, one aspect of the present invention provides a package of oxidizer for a propellant system for a motor in which said oxidizer is separated from fuel grain, said package comprising oxidizing material and an ignition system therefor in a wrapping or sealing material.

[0027] In preferred embodiments of the invention, the package is adapted to form a plurality of packages of oxidizing material in a stacked column.

[0028] In a further embodiment, the packages are adapted to be separated by an inhibitor layer.

[0029] In other embodiments, the packaging material is formed of material selected from polymer coated aluminum, aluminum coated with a mixture of polymer and magnesium, aluminum coated with a fluoroelastomer and magnesium, pyroalloying metal foil, and a pyrotechnic material consisting of laminates of magnesium foil and fluoropolymer, especially fluoropolymer sheet coated with magnesium or aluminum or alloys of magnesium and aluminum, nitrocellulose or double-based propellant.

[0030] In other embodiments, the ancillary compound is selected from the group consisting of a fluoropolymer, a fluoroelastomer, an energetic polymer, a non-energetic polymer, an energetic metal, a crystalline explosive, a polymerized peroxide and a double-based propellant. Preferably, the ancillary compound is a solid propellant formulated for stoichiometric oxygen balance or excess oxygen.

[0031] In further embodiments, oxidizer is separated from ancillary compound, said oxidizer being contained in ampoules within the ancillary compound. The oxidizer may be a liquid, a solid or a semi-solid material.

[0032] In additional embodiments, there is solid propellant composition formulated for at least stoichiometric oxygen balance.

[0033] The ampoules may contain carriers or performance enhancing compounds selected from the group consisting of a fluoropolymer, a fluoroelastomer, an energetic polymer, a non-energetic polymer, an energetic metal, a crystalline explosive, polymerized peroxide and a double-based propellant. The ampoule may be formed from coated aluminum, pyroalloying metal foil, or laminate or sheet of aluminum or magnesium, an energetic polymer, a non-energetic polymer, nitrocellulose and a double-based propellant, especially in which the coated aluminum is selected from polymer-coated aluminum, aluminum coated with a mixture of polymer and magnesium, and aluminum coated with a fluoroelastomer and magnesium.

[0034] A further aspect of the invention provides a hybrid rocket comprising oxidizing material and fuel grain, said oxidizing material being separated from the fuel grain and being in the form of a single package or plurality of packages of oxidizing material and an ignition system therefor, said packages generally conforming to the shape of the rocket.

[0035] Another aspect of the invention provides a grid of a pyrotechnical material, especially in which the grid is a matrix, mesh, wool, foamed metal or wires of said pyrotechnical material.

[0036] A further aspect of the invention provides a propulsion system for a hybrid rocket comprising oxidizing material in a matrix, mesh, wool, foamed metal or wires of structural or pyrotechnical material, especially in which the matrix, mesh, wool, foamed metal or wires enhance burn rate through thermal conductivity.

[0037] Another aspect of the invention provides a propulsion system for a hybrid rocket comprising a plurality of columns of oxidizing material, said columns being supported by a grid of structural and/or pyrotechnic material, especially in which the pyrotechnic grid material is designed to burn more quickly than the oxidizing material contained therein.

BRIEF DESCRIPTION OF THE DRAWING

[0038] The present invention is illustrated by the embodiments shown in the drawings, in which:

[0039] FIG. 1 is a schematic representation of a rocket of the present invention;

[0040] FIG. 2 is a schematic representation of another embodiment of a rocket of the present invention;

[0041] FIG. 3 is a schematic representation of a perspective view of a propellant grid;

[0042] FIG. 4 is a schematic representation of a cross-section of a hybrid rocket showing a package of propellant;

[0043] FIG. 5A is a schematic representation of a perspective view of a package with tubes, partly in section;

[0044] FIG. 5B is a schematic representation of a perspective view of a package with layers, partly in section;

[0045] FIG. 5C is a schematic representation of a perspective view of a package with spheres, partly in section;

[0046] FIG. 5D is a schematic representation of a perspective view of a package with cylindrical ampoules, partly in section;

[0047] FIGS. 6A-6F are a schematic representation of a cross-section of embodiments of packages, some showing burn patterns;

[0048] FIG. 7 is a schematic representation of a side view of packages of propellant in a rocket;

[0049] FIG. 8 is a schematic representation of an embodiment of an inhibitor disc; and

[0050] FIGS. 9A and 9B are schematic representations of exploded and assembled views of ampoules in a propellant matrix.

DETAILED DESCRIPTION OF THE INVENTION

[0051] Reference to oxidizer or oxidizing material in the context of this description refers either to the oxidizer compound or compounds themselves, or to the oxidizer compound or compounds in combination with other materials such as may be required to effect consolidation and/or binding, to modify the combustion characteristics, to modify storage stability, to modify sensitivity, or any other modifiers necessary to achieve required performance characteristics.

Nonetheless, the primary function of the oxidizing material is to supply oxidizing gases to support the combustion process of the rocket.

[0052] FIG. 1 shows an embodiment of a rocket, generally indicated by 1. Rocket 1 has oxidizer section casing 2 and fuel grain casing 3. Fuel grain casing 3 terminates in nozzle 4 and has an annular column of fuel grain 5. A wide variety of configurations of fuel grain 5 are known, particularly including star grain. Oxidizer section 2 and fuel grain casing 3 are separated by vent 6, which is a vent, particularly annular in design, for the passage of gases from the oxidizer section 2 into fuel grain casing 3.

[0053] Oxidizer section 2 has a plurality of stacked packages of oxidizer, indicated by 7A, 7B, 7C, 7D, 7E and 7F. It is understood that any number of oxidizer packages could be used from a single packet to a large number of packets, and that the packets could be of varying thickness or composition depending on the use of the rocket. It is also understood that the lowest package, oxidizer package 7A, would have an ignition system associated therewith. It is also preferred that an inhibitor layer separates each oxidizer package and that each has a separate ignition system for controlled delivery. Oxidizer 7 is described in greater detail below.

[0054] FIG. 1 also shows the optional vent plug 8. Vent plug 8 is located in vent 6, and is intended to ensure a build-up of pressure within the oxidizer section to a predetermined level, prior to passage of oxygen and other gases from the oxidizer section into the fuel grain casing 3.

[0055] FIG. 2 shows a rocket generally as shown in FIG. 1 but having optional embodiments. The rocket of FIG. 2 has spill ports 10 and 11 shown as located on the lower part of oxidizer section 2. Spill ports 10 and 11 are used to permit ambient air, particularly ambient oxygen to flow into oxidizer casing 2 and through vent 6 during use of the rocket. Such ambient oxygen would either mix with the oxidizing gases produced by combustion of the oxidizer packets, or be used alone and fed into the fuel grain casing. Spill ports 10 and 11 could optionally be located elsewhere.

[0056] FIG. 2 also shows basket 12 located within vent 6. Basket 12 has a plurality of perforations 13 that are of a size to retard the passage of large particulate from the oxidizer into the fuel grain casing. Flow distributor 14, also known as a gas-distributing plug or stem, has a plurality of distribution orifices 15. Flow distributor 14 is intended to distribute the flow of oxygen from the propellant casing within the fuel casing so as to permit more even use of fuel. It is understood that flow distributor 14 could be used with basket 12 or independently thereof.

[0057] FIG. 3 shows a package of oxidizer, generally indicated by 20. Oxidizer package 20 has a top 21 and a bottom 22, which are preferably planar and parallel. Thus oxidizer package 20 is preferably a right section of a cylinder of oxidizing material.

[0058] Oxidizer package 20 has a grid of structural and/or pyrotechnic material, 23, with the spaces 24 of the grid filled with oxidizer. It is preferred that the spaces 24 be volumetrically filled, i.e. such that there are no holes, voids, or porosity in the oxidizer. Thus, oxidizer package 20 is in the form of a plurality of columns of oxidizer, in a grid of pyrotechnic and/or structural material. The pyrotechnic material is preferably characterized by having a burn rate

that is faster than the oxidizer. Thus, on ignition, grid 23 burns away more quickly, exposing the columns of oxidizer with space therebetween formerly occupied by the grid. This increases the surface area of oxidizer that is burning, leading to a greater flow rate of oxidizing gases. Oxidizer package 20 would normally be covered with sealing or wrapping material that would hermetically seal the oxidizer from moisture or other contamination or exposure.

[0059] FIG. 4 shows a cross-section of oxidizer section casing 2 having oxidizer package 20 therein. Oxidizer 25 is within grid 23 and is in a plurality of columns perpendicular to the plane as viewed. Wrapping 26 is shown between oxidizer 25 and casing 2. It is understood that the package 20 should fit tightly within and optionally be bonded to casing 2, to prevent the flow of hot gases and burning around the perimeter during use.

[0060] Embodiments of the present invention will be particularly described herein with reference to the use of tubes of oxidizer in a matrix of ancillary compound in a package of oxidizer for a hybrid rocket. It is understood however that oxidizer could be used without ancillary compound. In addition, tubes are one embodiment of ampoules, which also include spheres, capsules, pellets, tubes, coatings or other forms in which compounds are hermetically sealed from the oxidizer. The ampoules could be pressurized. Moreover, use of the ampoules may be made in solid fuel rockets to incorporate compounds that enhance the performance of the rocket. Such compounds may be liquid, solid or semi-solid.

[0061] A variety of compounds may be hermetically sealed in ampoules. In particular embodiments, oxidizer is incorporated into ampoules, such that oxidizer in ampoules is located in a matrix of ancillary compound. However, the ampoules may contain other compounds, admixed with oxidizer or in separate ampoules. Such other compounds include compounds that are not otherwise readily incorporated into compositions of oxidizer, for reasons of mechanical or physical properties e.g. incorporation of the compound into the oxidizer would result in unacceptable physical properties of the oxidizer, such as brittleness, tensile strength, composition integrity, etc. The compounds also include compounds that are hygroscopic, react with oxidizer or other component of the matrix of the oxidizer composition e.g. metals, curing agent, binder, or the like, with consequent issues of toxicity, safety or composition integrity etc. Some reasons for use of ampoules may relate to factors encountered during processing and other manufacture of the oxidizer compositions. Other types of compounds or compositions have been discussed above. It is understood that the compounds in the ampoules would cause benefits to the performance of the oxidizer.

[0062] The invention is also described herein with reference to the preferred embodiment in which the oxidizer is in a package. In other embodiments, the package may be omitted, thereby providing an oxidizer system without packaging.

[0063] FIG. 5A shows a package of oxidizer, generally indicated by 33. Package 33 has a matrix 34 of oxidizer containing ancillary compound in the form of a right cylinder. It is understood that matrix 34 would have the oxidizer and ancillary compound in a binder, as described herein. Package 33 is shown without any wrapping material. Matrix

34 has a plurality of tubes **35** therein. In the embodiment shown, tubes **35** are aligned parallel to axis **36** of package **33**, and are fully enveloped with matrix **34** of oxidizer and ancillary compound. It is understood that the tubes could be in other forms of sealed entities e.g. ampoules, packets or the like, preferably in a substantially uniform distribution. **FIGS. 5B-5D** show other examples. In **FIG. 5B**, the tubes have been replaced with layered ampoule sections, which could be radial overlapping layers or other layered shapes. In **FIGS. 5C and 5D**, the tubes have been replaced with spheres and cylindrical ampoules, respectively. The tubes, ampoules, layers etc would contain highly energetic or high performance oxidizer.

[0064] **FIG. 6** shows six examples of cross-sections of packages, some of which also show examples of burn patterns. It is understood that other examples of packages and burn patterns could be used.

[0065] **FIG. 6A** shows a plurality of tubes **35** arrayed in a pattern extending from a source of ignition **37** of the package.

[0066] **FIG. 6B** shows a cylindrical package having three sections **38A, 38B and 38C**, each with matrix **34** and tubes **35**. Sections **38A, 38B and 38C** are separated by inhibitor material **39**. Inhibitor material **39** is intended to permit ignition of one section of the package e.g. section **38A**, while preventing ignition of adjacent packages **38B and 38C**. In this manner, ignition of oxidizer in the package may be carried out in a controlled manner, with ignition of one, or of all of sections **38A, 38B and 38C** at any one time.

[0067] **FIG. 6C** shows a different array of sections. Sections **40A, 40B, 40C and 40D** are in concentric circles, each with matrix **34** and tubes **35**. Sections **40A, 40B, 40C and 40D** are separated by inhibitor material **41**. One or more of sections **40A, 40B, 40C and 40D** could be ignited at any one time, and it would be normal to do so from the centre of the package.

[0068] **FIG. 6D** shows the embodiment with burn patterns **44** if ignition is simultaneously made at each of points of ignition **42A, 42B, 42C, and 42D**.

[0069] **FIG. 6E** shows a burn pattern from a single ignition, at **42A**.

[0070] **FIG. 6F** shows the burn pattern if ignition is at opposed points of ignition **42A and 45C**.

[0071] Thus, it is to be understood that the packages could be separated into sections e.g. semi-circular sections, tri-sections and quadrants. Any convenient number of sections could be used. Each section may be initiated separately or in any combination or sequence. In addition, more than one initiator may be used e.g. 2-4 initiators, as illustrated in **FIG. 6**.

[0072] **FIG. 7** shows a side view in section of oxidizer casing **2** having packages of oxidizer therein. Oxidizer section casing **2** has packages **7A and 7B** with other packages not shown. Package **7A** has initiator **36** associated therewith, as well as wrapping/sealing material **45A**. It is understood that the package of oxidizer could have initiator **46** within the sealed package or separate therefrom. If separate, it is understood that the initiator would need to perforate the wrapping or sealing material so as to initiate the oxidizer.

[0073] Oxidizer package **7B** is located above oxidizer package **7A** and has initiator **47** associated therewith. Oxidizer package **7B** is sealed by material **45B**. Oxidizer package **7B** is separated from oxidizer package **7A** by inhibitor **48**. Inhibitor **48** is intended to prevent the ignition of oxidizer package **7B** by the combustion of oxidizer package **7A** in an uncontrolled manner. It is intended that oxidizer **7B** would be ignited by initiator **47** at the appropriate timing.

[0074] It is understood that initiator **46 and 47** would have the appropriate electrical wiring, optical coupling, pyrotechnic coupling and timing, or other means to permit ignition of the respective oxidizer packages in the required sequence.

[0075] **FIG. 8** shows one example of an inhibitor shown as disc **50**. Disc **50** would be formed of ceramic **51** or of any other suitable material that would not burn under conditions of use although it may ablate or char. Disc **50** has a plurality of holes **52**, which would preferably be tapered holes with the larger dimension on the underside of disc **50**. In this way, when oxidizer above disc **50** is initiated, plugging material in holes **52** would be forced downwards thereby permitting gases to pass through disc **50**. However, combustion of oxidizer beneath disc **50** would not result in the material in holes **52** from being pushed upwards.

[0076] The oxidizer or oxidizing material, in combination with ancillary compound or separate therefrom, could consist of a single oxidizing compound or a blend of oxidizing compounds consolidated by pressure or melt-cast. Preferably, the oxidizing material would consist of an oxidizing compound or compounds in combination with binding (ancillary) material as used in solid propellant rocket motor systems. Examples of such binding materials are thermoset polymers such as HTPB, PBAN, epoxies and others, thermoplastic polymers such as ethylene/vinyl acetate co-polymer, or energetic polymers such as GAP, BAMO/AMMO or BAMO/NMMO. Nonetheless, binder systems and processing techniques therefor are known for solid propellant compositions, and such systems are applicable to this invention, as are any others that may be selected or required by compatibility, performance, or structural issues.

[0077] Examples of thermoplastic polymer propellant compositions and especially binders for such compositions are described in greater detail in Canadian Patent Application No. 2,243,245, published Jul. 15, 1998. For example, the binder could be polyethylene/vinyl acetate (EVA) or similar polymer, optionally cross-linked.

[0078] It is understood that the stoichiometry of oxidizing compositions used in this invention would be adjusted such that combustion of the composition results in the generation of gases containing an excess of free oxygen or other oxidizing elements. Thus, the oxidizing material will contain at least 80% by weight of oxidizer or oxidizers, and particularly greater than 90% by weight of oxidizer or oxidizers. The use of the ampoules permits an increase in the overall amount of oxidizer, while maintaining integrity of the compositions.

[0079] A variety of oxidizers known to the trade may be used, including but not limited to solid or semi-solid oxidizers such as ammonium perchlorate, ammonium nitrate, ammonium dinitramide, hydroxylammonium nitrate, hydroxylammonium perchlorate, hydrazinium nitroformate,

nitronium perchlorate; liquid or semi-solid such as nitric acid, hydrogen peroxide. Alternatively, the oxidizer may be a so-called double based propellant i.e. nitrocellulose/nitroglycerine, optionally including ballistic modifiers, which may be alloyed with fluorine-containing polymers or other polymers to improve mechanical properties. The ratio of nitrocellulose (NC) to nitroglycerine (NG) may be varied to achieve a neutral or positive oxygen balance with increasing percentages of NG. With some ballistic modifiers e.g. copper and lead-based ballistic modifiers, double-based propellants may exhibit so-called plateau burning e.g. the propellant exhibits a substantially constant burn rate. Plateau burning, and reduced burn rates at higher pressures could act as a safety mechanism should the surface area of the propellant change e.g. due to voids, cracks or other problems. It is understood that other oxidizers could be used.

[0080] It is also known that modifiers may be used in the oxidizing material. Such modifiers are known as used in solid propellant systems. Examples of modifiers would be burn rate modifiers such as ferrocene or ferrocene derivatives, borohydrides, copper chromite, oxamide, oxides or fluorides of iron, chromium, copper, lithium, magnesium, and others; thermally-conductive burn rate modifiers such as silver wire or graphite whiskers; coupling agents/rheology modifiers such as titanates, zirconates, aluminates; bonding agents; opacifiers, stabilizers, metal de-activators, anti-oxidants, or other agents known to the trade to modify processing, performance, mechanical properties, storage stability, munitions sensitivity, or shelf life.

[0081] In addition to the above, the oxidizing material may contain one or more of the following; fuel additives, e.g. metal or non-metal powders, metal hydrides; energetic materials e.g. crystalline explosives such as HMX or RDX, liquid explosives such as TMETN or BTTN.

[0082] In embodiments of the invention, the propellant composition may be 90-94% oxidizer, 2.5-4.5% ancillary compounds, 0.5-1.0% burn rate modifiers, 0.5-1.0% energetic metals, 0.2-0.5% process modifiers and 0.2-0.4% curative agents in binder. The process modifiers and curative agents relate to the particular binder system that is used, as will be understood.

[0083] In preferred embodiments, the package of the present invention contains oxidizer and ancillary compound. The ancillary compound undergoes exothermic decomposition on decomposition of the oxidizer in the propellant system, with the exothermic decomposition being substantially without consumption of oxygen from the oxidizer. In particular, less than 10% of the oxidizer is consumed on said exothermic decomposition. In preferred embodiments, less than 5% of the oxidizer is consumed on said exothermic decomposition, and more preferably exothermic composition occurs without consumption of oxygen from the oxidizer.

[0084] The ancillary compound is selected from the group consisting of a fluoropolymer, a fluoroelastomer, and energetic polymer, a crystalline explosive and a polymerized peroxide. Examples of the fluoropolymer are perfluorinated polymers and other fluorine polymers e.g. fluorinated hydrocarbons, including polymers available under the trademarks Teflon and Viton, and those known as KEL-F. The fluoropolymers may be used in an uncross-linked form, or cross-linked. For example, Viton polymers may be cross-

linked with diamines e.g. Diak, bisphenol, dihydroxy compounds e.g. Viton curatives **20** and **30**, and peroxides, as is known.

[0085] Examples of the fluoroelastomer are available under the trademark Viton or polyfluorinated polyols. Examples of the latter include polyperfluoro polyether polyols of the formula $\text{HOCO}_2\text{CF}(\text{CF}_3)\text{O}(\text{C}_2\text{F}_4)_n\text{O}[\text{CF}(\text{CF}_3)\text{CF}_2\text{O}]_m\text{OCF}(\text{CF}_3)\text{CH}_2\text{OH}$, where $n=1-20$. A preferred polyol has $n=5$.

[0086] Examples of the energetic polymer are GAP and BAMO.

[0087] Examples of crystalline explosives are TNT, RDX and HMX.

[0088] Examples of peroxide are hydrogen peroxide.

[0089] The amount of ancillary compound may be varied over a wide range e.g. from about 1% to 20% by weight and especially from about 5% to 15% by weight, based on the weight of the oxidizer.

[0090] The oxidizer may be selected from a wide variety of oxidizers, but some oxidizers will not be compatible in such compositions, as has been discussed herein. These oxidizers, which are generally highly energetic or high performance oxidizers, must be packaged separately, and this is done using the sealed ampoules. Thus in preferred embodiments, a highly energetic oxidizer is physically separated from the oxidizer and ancillary compound by means of ampoules for example tubes. Thus, the high performance oxidizer is contained within a plurality of tubes, with the tubes being dispersed within the matrix of oxidizer and ancillary compound material. Examples of the highly energetic oxidizers include HAP, HAN, ADN, HNF, nitronium perchlorate and ClO_2 compounds. For example, HNF has been shown to react with a number of common curatives used in solid propellant binder systems.

[0091] The ampoules may be formed from coated aluminum, especially in which the coated aluminum is selected from polymer coated aluminum, aluminum coated with a mixture of polymer and magnesium, and aluminum coated with a fluoroelastomer and magnesium. Alternatively, the ampoules are formed from pyroalloying metal foil or from laminates or sheet of magnesium and fluoropolymer. The ampoules may also be formed from polymers especially reactive polymers, examples of which include fluorinated polymers, engineering polymers e.g. nylon, nitrocellulose. Polymers containing fluorine undergo strong exothermic reactions with a variety of metals, especially aluminum and magnesium. Other materials may be used, provided that the materials effectively seal the contents of the ampoules from the matrix of oxidizer. Hydrocarbon polymers should not be used as they consume substantial amounts of oxygen during combustion.

[0092] The package is in a wrapping or sealing material, and is preferably hermetically sealed but in some instances should be breathable, as will be understood. However, in some instances, it is preferred that the packages be breathable i.e. that the packages not be hermetically sealed. The nature of the packages will depend on the composition within the package. The packages should be stackable in a column. If tubes are used, the tubes should be aligned parallel to the axis of the column.

[0093] FIGS. 9A and 9B illustrates one example of an assembly of ampoules in a propellant matrix. In the exploded view of FIG. 9A, a matrix 60 of propellant is fabricated to have a multitude of recesses 61. The recesses 61 are cooperatively located so that each pair of recesses will accept an ampoule 62. Matrix 60 may be fabricated by a variety of techniques including casting, extrusion and the like. Ampoules 62 contain oxidizer 63 and have a shell 64 formed from, for example, fluoroelastomer-coated aluminum or magnesium.

[0094] FIG. 9B shows the assembled matrix with ampoules. The assembled matrix would typically have a casing (not shown).

[0095] The composition of oxidizer and ancillary compound may be manufactured using either hot or cold pressure consolidation techniques. In addition, the compositions of oxidizer and ancillary compound may be manufactured with or without use of vacuum. Examples of methods of manufacture are disclosed in the aforementioned Canadian Patent Application 2,243,245. The ampoules may be incorporated using such processes.

[0096] The compounds in the ampoules may be in liquid or solid form or semi-solid, including powders and crystalline forms. If powder or crystalline forms are used, the interstices should be filled with a liquid that further enhances the performance of oxidizer.

[0097] The ampoules should be incorporated into the matrix of ancillary in a uniform, consistent or patterned manner. This permits a degree of predictability to the oxidizer system. However, it is understood that there may be limited control in the process of manufacture to achieve uniformity, consistency or patterns.

[0098] The present invention provides a propulsion system for a rocket. The propulsion system utilizes an oxidizer section containing a package or plurality of packages of oxidizing material. The packages of the present invention permit ratios of oxygen to fuel in the rocket to be varied, by using different combinations of packages.

[0099] In embodiments, the packages consist of a plurality of columns of oxidizing material, with the columns being supported by a grid of a structural and/or pyrotechnic material. In a preferred embodiment, the grid is constructed of a pyrotechnic material that upon ignition of the face of the grid, the grid material burns more quickly than the oxidizing material thereby exposing the columns of oxidizing material for more rapid combustion.

[0100] The oxidizing material is normally in the form of an admixture of oxidizer and binder, and the grid is preferably a honeycomb. The oxidizing material is formulated such that the combustion products yield a net excess of oxygen or other oxidizing species. The packages should have complete volumetric loading such that no voids, fissures, or other porosity exists.

[0101] The present invention provides a grid of a pyrotechnical material, with the grid having opposed planar faces and voids extending therethrough. Preferably, the voids are columns, especially columns that are square, rectangular, hexagonal, or circular in cross-section. In particularly preferred embodiments of the invention, the grid is in the shape of a right section of a cylinder.

[0102] In embodiments, the grid is coated aluminum or nitrocellulose. If the grid is formed of coated aluminum, then it is preferably polymer coated aluminum, aluminum coated with a mixture of polymer and magnesium, or aluminum coated with a fluoroelastomer and magnesium.

[0103] In further embodiments, the grid may be constructed of a pyroalloying metallic foil, or of a laminate of fluoropolymer sheet and magnesium foil, or of magnesium coated fluoropolymer sheet.

[0104] In further preferred embodiments, the oxidizing material is packaged in a wrapping or coating material, in which the packages are hermetically sealed and stackable in a column.

[0105] In the rocket of the invention, the packages are preferably separated by an inhibitor layer, each package having an ignition system. The rocket would normally have a plurality of packages of oxidizing material in a stacked column.

[0106] The oxidizer section of the rocket would normally contain a vent to allow oxidizing gases to flow from the oxidizer section into the fuel grain section. The vent may have a pressure-activated control valve. The oxidizer section may contain a structure for preventing large particulate matter to flow into the fuel grain section. This structure could consist of a perforated basket incorporated into the vent assembly, with perforations of a size to control the flow of particulate matter into the fuel grain. Other means include a filter screen located downstream of the oxidizer packages consisting of a porous material capable of functioning in a high temperature oxidizing environment, such as sintered metal or ceramic, or foamed ceramics.

[0107] The vent may also incorporate a gas-distributing plug or stem therein, the plug or stem extending into the fuel grain section to effect distribution of the oxidizing gases.

[0108] The rocket may also contain spill ports/intakes for the entry of ambient air as sole or supplemental air. These could be located in the oxidizer section, or in the fuel grain section. The purpose of these ports would be to admit ambient air, particularly ambient oxygen, into the rocket either to supplement the oxidizing gases from the oxidizing material contained therein, or to supply the sole source of oxygen during selected periods of operation where the oxidizer section is inactive or has completed functioning. In the latter cases the rocket could be referred to as operating as a ramjet or scramjet.

[0109] The invention permits consolidation of high performance solid, semi-solid and/or liquid oxidizers into individual high density sealed packages. These packages would be stored in the oxidizer section of the rocket and could be delivered at a controlled rate to the combustion chamber. Throttling and start/stop capabilities which are inherent characteristics and benefits of propulsion systems would be realized. Delivery of these packets could be accomplished by a number of means such as pyrotechnics, gas charge or either method in combination with acceleration forces. Geometry of the packages can be tailored to optimize packaging, structural efficiency, delivery systems and performance. Storage stability, safety and munitions sensitivity could be improved while realizing the performance benefits of these high performance oxidizers.

[0110] Propulsion systems offer a number of potential advantages over conventional solid propellant rocket propulsion systems especially when used in conjunction with high performance oxidizers. These advantages include increased bulk-loading potential plus deployment and long-term stability, as well as easily configurable thrust profiles including start/stop and throttling capability.

[0111] Packaging the oxidizer in hermetically-sealed packets minimizes environmental exposure, and offers the ability to utilize high performance oxidizers that normally present severe difficulties in solid propellant formulation. Hermetically sealed packages offer the potential for improved storage, deployment and long term stability.

[0112] Rocket systems using high performance oxidizers have commercial applications in military and non-military propulsion systems. The benefits of rocket propulsion could improve the flexibility and capabilities of these systems.

[0113] As noted above, the ampoules may also be used with solid fuel rockets e.g. rockets utilizing PBAN or HTPB, to provide additional compounds to enhance the performance of the rocket. As described above, the compounds in the ampoule would be compounds that cannot be incorporated into the solid fuel per se for reasons of physical properties, chemical properties or other characteristics, or which otherwise enhance performance of the rocket. Examples of compounds include beryllium hydrides and the like.

[0114] The present invention is illustrated by the following examples.

EXAMPLE I

[0115] A number of samples of potential propulsion systems were prepared using grids described herein. Hexagonal grids as illustrated in FIG. 4 were prepared using the following pyrotechnical material:

[0116] (i) fluoropolymer (TeflonTM)—coated magnesium

[0117] (ii) fluoropolymer (VitonTM)—coated aluminum

[0118] (iii) microfoamed GAP

[0119] (iv) pyro-alloying metal foil e.g. aluminum—palladium

[0120] (v) nitrocellulose

[0121] The hexagonal grids had a thickness in the range of 10 to 1000 microns, with each hexagon of the grid being about 3 to 20 cm in diameter.

[0122] Examples of the grid were filled with compositions of 90-94% ammonium perchlorate containing an ancillary compound selected from Viton B, Viton B-50 and Viton B-200 fluoropolymers, low molecular weight fluoroelastomer viz. dipolymer of hexafluoropolymer and difluoroethane, optionally cross-linked with Diak diamine, double-based (NC/NG) propellant, GAP 5527 or PFPE polyol viz. the polyperfluoro polyether polyol described above.

[0123] Samples of the filled grids were successfully subjected to firing tests in a test motor.

EXAMPLE II

[0124] Samples of the grid in Example I were packaged in a paper/phenolic laminate tubular inhibitor sleeve and equipped with an initiator. The samples were successfully subjected to firing tests.

EXAMPLE III

[0125] For testing of samples, a test solid propellant motor was fabricated in a modular form. The motor had a casing that was 2.5 inches (6.3 cm) in diameter and was capable of receiving one, two or three ancillary grains/packets of 1.025 inches (2.60 cm) in length. The motor was typically used with an inhibitor plate as disclosed herein, and appropriate end closures. The motor was similar in design to that of FIG. 1, except that it was intended for laboratory testing.

[0126] The motor was successfully loaded and fired with samples fabricated according to the procedure of Example I on numerous occasions.

EXAMPLE IV

[0127] A propellant composition was formulated as follows:

	Wt %
Ammonium perchlorate, spherical, 200 micron	56.0
Ammonium perchlorate, ground, 15 micron	21.6
GAP polyol	12.7
GAP plasticizer	5.6
Bonding agent	0.046
Antioxidant/metal deactivator	0.10
Diisocyanate curative	1.6
Superfine Iron oxide	0.25
Carbon black	0.050
Aluminum, spherical, 2 micron	2.0

[0128] A grain was formed using the above propellant, with GAP enclosed in ampoules imbedded in the propellant.

[0129] Characterization firings were performed in a 1.5 inch (3.8 cm) micro-motor using single Bates grain with approximately 50 g propellant mass. A burn rate of 1.5 inches/second was achieved at 500 psia chamber pressure.

[0130] This example illustrates use of ampoules in propellants. The formulation was not optimized.

1. An oxidizer package for a propellant system for a motor in a rocket, the oxidizer package comprising:

coated oxidizer material disposed in a matrix; and

an ignition system therefor,

wherein the matrix is selected from the group consisting of an ancillary compound, a mixture of an oxidizer and an ancillary compound, and a pyrotechnic material.

2. The package of claim 1, wherein the coated oxidizer material is hermetically sealed.

3. The package of claim 1, wherein the coated oxidizer material has a coating selected from the group consisting of at least one of coated aluminum, pyroalloying metal foil, a laminate or sheet of aluminum, a laminate or sheet of magnesium, an energetic polymer, a non-energetic polymer, nitrocellulose and a double-base propellant; the coated alu-

minum is selected from the group consisting of polymer-coated aluminum, aluminum coated with a mixture of polymer and magnesium, and aluminum coated with a fluoroelastomer and magnesium.

4. The package of claim 1 wherein the coated oxidizer material has an oxidizer material selected from the group consisting of a liquid, a solid and a semi-solid material.

5. The package of claim 1 wherein the coated oxidizer material has an oxidizer material that comprises at least one oxidizer.

6. The package of claim 1 wherein the coated oxidizer material has an oxidizer material that comprises a mixture of an oxidizer and an ancillary compound.

7. The package of claim 1 wherein the ancillary compound is selected from the group consisting of a fluoropolymer, a fluoroelastomer, an energetic polymer, a non-energetic polymer, an energetic metal, a crystalline explosive, a polymerized peroxide and a double-base propellant.

8. The package of claim 6 wherein the ancillary compound of the oxidizer material is selected from the group consisting of a fluoropolymer, a fluoroelastomer, an energetic polymer, a non-energetic polymer, an energetic metal, a crystalline explosive, a polymerized peroxide and a double-base propellant.

9. The package of claim 1 wherein the ancillary compound of the matrix is a solid propellant formulated for stoichiometric oxygen balance or excess oxygen.

10. The package of claim 6 wherein the ancillary compound of the oxidizer material is a solid propellant formulated for stoichiometric oxygen balance or excess oxygen.

11. The package of claim 1 wherein the oxidizer is selected from the group consisting of a liquid, a solid and a semi-solid material.

12. The package of claim 1 wherein the coated oxidizer material further comprises carriers or performance enhancing compounds selected from the group consisting of a fluoropolymer, a fluoroelastomer, an energetic polymer, a non-energetic polymer, an energetic metal, a crystalline explosive, polymerized peroxide, a metal hydride and a double-base propellant.

13. The package of claim 1 wherein the matrix is the ancillary compound.

14. The package of claim 1 wherein the matrix is the oxidizer and the ancillary compound.

15. The package of claim 1 wherein the matrix is the pyrotechnic material.

16. The package of claim 1 wherein the ancillary compound is selected from the group consisting of HTPB, PBAN, epoxy, thermoplastic polymer, GAP, BAMO, AMMO, NMMO and mixtures thereof.

17. The package of claim 6 wherein the ancillary compound of the oxidizer material is selected from the group consisting of HTPB, PBAN, epoxy, thermoplastic polymer, GAP, BAMO, AMMO, NMMO and mixtures thereof.

18. The package of claim 1 wherein the matrix is polyethylene/vinyl acetate (EVA), optionally cross-linked.

19. The package of claim 1 wherein the oxidizer is selected from the group consisting of ammonium perchlorate, ammonium nitrate, ammonium dinitramide, hydroxylammonium nitrate, hydroxylammonium perchlorate, hydrazinium nitroformate, nitronium perchlorate, nitric acid, hydrogen peroxide and nitrocellulose/nitroglycerine.

20. The package of claim 1 wherein the coated oxidizer material has an oxidizer material selected from the group consisting of ammonium perchlorate, ammonium nitrate, ammonium dinitramide, hydroxylammonium nitrate, hydroxylammonium perchlorate, hydrazinium nitroformate, nitronium perchlorate, nitric acid, hydrogen peroxide and nitrocellulose/nitroglycerine.

21. The package of claim 1 wherein the matrix comprises 90-94% oxidizer, 2.5-4.5% ancillary compounds, 0.5-1.0% burn rate modifiers, 0.5-1.0% energetic metals, 0.2-0.5% process modifiers and 0.2-0.4% curative agents.

22. The package of claim 1 wherein the matrix is a grid of the pyrotechnical material.

23. The package of claim 22 wherein the grid is selected from the group consisting of mesh, wool, foamed metal and wires.

24. The package of claim 1 wherein the pyrotechnic material has a burn rate faster than the oxidizer material.

25. The package of claim 1 wherein the pyrotechnic material is selected from the group consisting of polymer-coated aluminum, aluminum coated with a mixture of polymer and magnesium, aluminum coated with a fluoroelastomer and magnesium, pyroalloying metal foil, laminates of magnesium foil and fluoropolymer, a fluoropolymer sheet coated with magnesium, a fluoropolymer sheet coated with aluminum, a fluoropolymer sheet coated with an alloy of magnesium and aluminum, nitrocellulose and double-base propellant.

26. The package of claim 1 wherein the ancillary compound undergoes exothermic decomposition substantially without consumption of oxygen from the oxidizer material.

27. The package of claim 1 wherein the package is hermetically sealed.

28. The package of claim 1 wherein the package is a breathable package.

29. The package of claim 1 wherein the motor is a hybrid rocket motor.

30. The package of claim 1 wherein the motor is a breathable rocket motor.

31. The package of claim 1 wherein the motor is a combined hybrid and breathable rocket motor.

32. The package of claim 1 wherein the motor is a solid rocket motor.

33. The package of claim 1 wherein the motor is a scramjet.

34. The package of claim 1 wherein the motor is a ramjet.

35. The package of claim 29 wherein the packages are adapted to be separated by an inhibitor layer.

36. The package of claim 35 wherein the package is adapted to form a plurality of packages of oxidizing material in a stacked column.

37. The package of claim 35 wherein the package is in the shape of a right section of a cylinder.

38. The package of claim 37 wherein said right cylinder is divided into more than one section.

39. The package of claim 38 wherein said sections are selected from semi-circles, tri-sections and quadrants.

40. The package of claim 37 wherein the package has a circular cross-section with parallel planar opposing ends.