



US 20040188880A1

(19) **United States**

(12) **Patent Application Publication**
Bauer et al.

(10) **Pub. No.: US 2004/0188880 A1**

(43) **Pub. Date: Sep. 30, 2004**

(54) **PRODUCTION OF MOLDED ARTICLES FOR LITHIUM ION BATTERIES**

(76) Inventors: **Stephan Bauer**, Hochdorf-Assenheim (DE); **Franz Weingart**, Leimen (DE); **Bernd Bronstert**, Otterstadt (DE); **Helmut Mohwald**, Annweiler (DE); **Thomas Kessler**, Schifferstadt (DE); **Uwe Burkhardt**, Frankenstein (DE); **Florian Hennenberger**, Limburgerhof (DE)

Correspondence Address:
Herbert B. Keil
KEIL & WEINKAUF
1350 Connecticut Ave., N.W.
Washington, DC 20036 (US)

(21) Appl. No.: **10/824,496**

(22) Filed: **Apr. 15, 2004**

Related U.S. Application Data

(62) Division of application No. 09/381,500, filed on Sep. 22, 1999, filed as 371 of international application No. PCT/EP98/01763, filed on Mar. 25, 1998.

(30) **Foreign Application Priority Data**

Mar. 27, 1997 (DE)..... 19713072.0

Publication Classification

(51) **Int. Cl.⁷ D04H 1/00**

(52) **U.S. Cl. 264/109**

(57) **ABSTRACT**

A method for producing a molded article, preferably a sheet-type molded article, which method comprises the following stage:

- I) Compounding and melt extrusion of a mixture I which comprises a blend II which contains:
 - a) from 1 to 95 wt % of at least one pigment III having a primary particle size of from 5 nm to 20 nm which is selected from the group consisting of an electrochemically inert solid IIIa, a compound IIIb which during charging is able to give off lithium ions, and a compound IIIc which during charging is able to take up lithium ions, and a mixture of the solid Ma with the compound IIIb or the compound IIIc,
 - b) from 5 to 99 wt % of at least one polymeric binder IV, and
 - c) from 0 to 200 wt %, based on the total amount of the components a) and b), at least one plasticizer V,

wherein the proportion by weight of the blend II in the mixture I is from 1 to 100 wt %, and

wherein mixtures I comprising blends II containing, as the polymeric binder IV, a copolymer of vinylidene fluoride (VdF) and hexafluoropropylene (HFP) having an HFP content of from 8 to 25 wt % and, as the plasticizer V, a compound selected from the group consisting of dibutyl phthalate, dimethyl phthalate, diethyl phthalate, tris(butoxyethyl)phosphate, propylene carbonate, ethylene carbonate, trimethyl trimellitate and mixtures thereof are excluded.

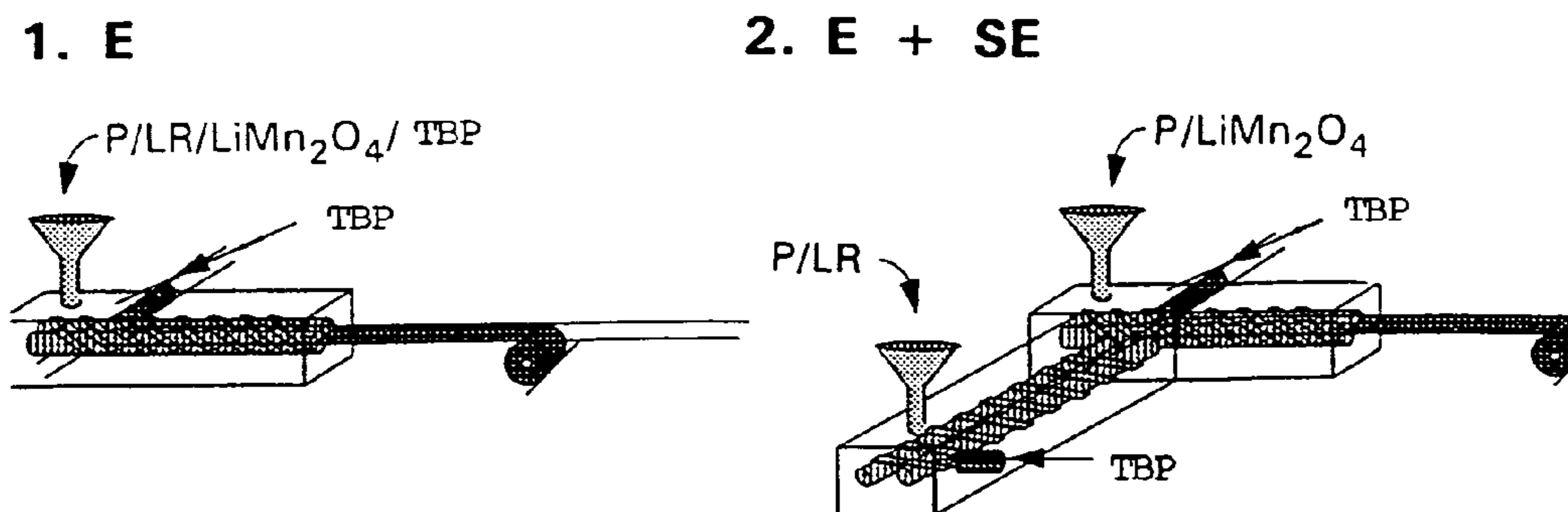

Fig. 1

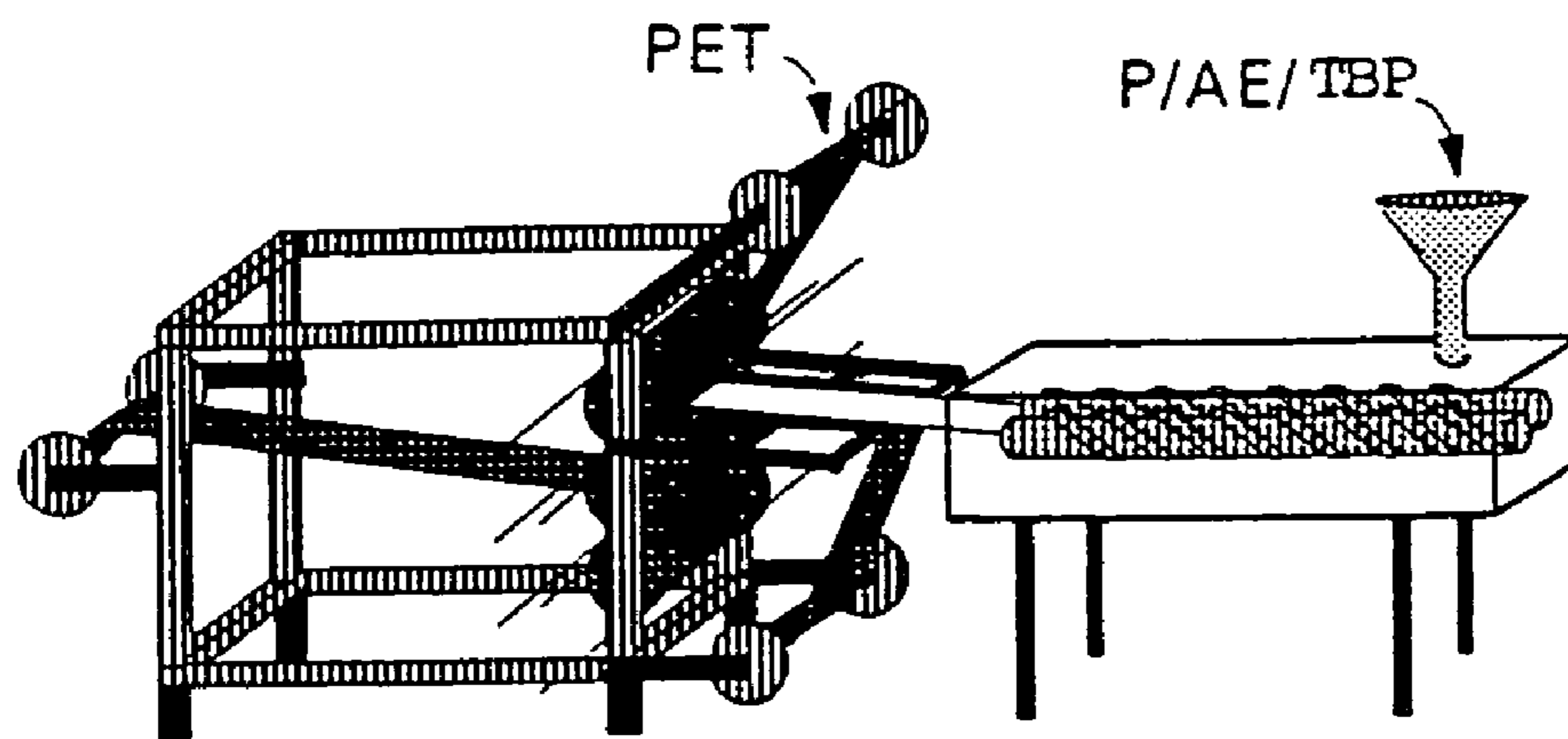

Fig. 2

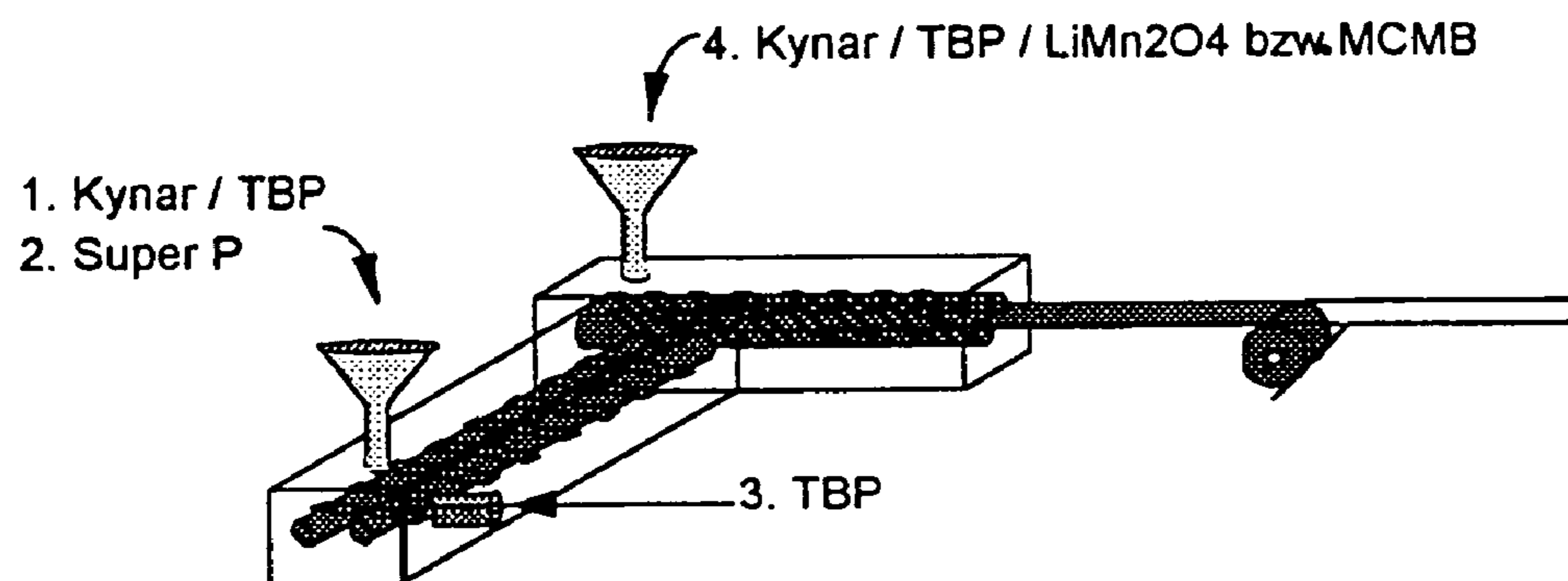

Fig. 3

PRODUCTION OF MOLDED ARTICLES FOR LITHIUM ION BATTERIES

[0001] The present invention relates to a method for the production of molded articles suitable, inter alia, as solid electrolytes, separators and electrodes for electro-chemical cells, and preferably of sheet-type molded articles for electrochemical cells by melt extrusion; solid electrolytes, separators, electrodes, sensors, electrochromic windows, displays, capacitors and ion-conducting foils per se which, in each case, comprise such a molded article; and electrochemical cells comprising such solid electrolytes, separators and/or electrodes.

[0002] Electrochemical cells, in particular rechargeable ones, are generally known, for example from "Ullmann's Encyclopedia of Industrial Chemistry", 5th edition, Vol. A3, VCH Verlagsgesellschaft mbH, Weinheim, 1985, pp. 343-397.

[0003] Among these cells, a special position is occupied by lithium batteries and lithium ion batteries, in particular as secondary cells, owing to their high specific energy storage density.

[0004] As described inter alia in the above quotation from "Ullmann", such cells include, in the cathode, mixed oxides containing lithium ions and ions of manganese, of cobalt, of vanadium or of nickel, such mixed oxides being suitably described, in the stoichiometrically simplest case, as LiMn_2O_4 , LiCoO_2 , LiV_2O_5 or LiNiO_2 .

[0005] These mixed oxides react reversibly with compounds which are able to intercalate lithium ions into their lattice, for example graphite, the lithium ions being removed from the crystal lattice and the metal ions such as manganese ions, cobalt ions or nickel ions in this lattice being oxidized in the process. This reaction can be utilized in an electrochemical cell for storing electrical energy by the compound which takes up the lithium ions, in other words the anode material, and the lithium-containing mixed oxide, in other words the cathode material, being separated by an electrolyte for which the lithium ions migrate from the mixed oxide into the anode material (charging operation).

[0006] In so doing, the compounds suitable for storing lithium ions reversibly are usually fixed on collector electrodes by means of a binder.

[0007] When the cell is charged, electrons flow through an external voltage source and lithium cations through the electrolyte towards the anode material. When the cell is utilized, the lithium cations flow through the electrolyte, whereas the electrons flow through a load from the anode material to the mixed oxide (cathode material).

[0008] So as to avoid a short circuit within the electrochemical cell, inbetween the two electrodes there is an electrically insulating, but lithium cation-permeable layer, a solid electrode or separator.

[0009] As is known, solid electrolytes and separators consist of a support material into which a dissociable compound containing lithium cations is incorporated to enhance the lithium ion conductivity, as are, normally, further additives such as solvents.

[0010] In this context a solid electrolyte is understood to be a material which can either be used without a solvent in

the electrochemical cells or which, in the case of a solvent being used, largely contains the latter in physically bound form.

[0011] To prepare the solid electrolytes or separators, the general approach is to apply a solution from the support material, the compound containing lithium cations and, if required, further additives to a support, and the solvent is then evaporated.

[0012] One support material, proposed e.g. by U.S. Pat. No. 5,540,741 and U.S. Pat. No. 5,478,668, is a copolymer from vinylidene difluoride and hexafluoropropene.

[0013] Production of these battery foils in accordance with the above publications involves dispersing the solid, plasticizer and binder (see Table).

	Anode	Cathode	Separator
Solid	Graphite	LiMn_2O_4	Aerosil
Plasticizer	Dibutyl phthalate	Dibutyl phthalate	Dibutyl phthalate
Binder	COPO (PVDF/HFP)	COPO (PVDF/HFP)	COPO (PVDF/HFP)
Solvent	Acetone	Acetone	Acetone
Extractant	Diethyl ether	Diethyl ether	Diethyl ether

[0014] The dispersion is then cast, and the film is dried. Then the plasticizer is extracted with diethyl ether. The binder is a random copolymer of vinylidene fluoride and hexafluoropropene (8-25%).

[0015] The method described there has the following drawbacks:

- [0016] 1. Use of organic solvents
- [0017] 2. Film has to be dried
- [0018] 3. Extraction of the plasticizer is required
- [0019] 4. The extractant is explosive
- [0020] 5. Extraction of plasticizer from the sheet is not 100% effective.

[0021] Also known are solid electrolytes on the basis of poly-(alkylene oxides); these solid electrolytes are described e.g. in EP-A 559 317, EP-A 576 686, EP-A 537 930, EP-A 585 072 and U.S. Pat. No. 5,279,910. The polyethers described there are modified at the end groups or functional groups, e.g. by (meth)acryloyl groups, and are cross-linked, prior to being used as a solid electrolyte, by means of energy input (heat, light). Additionally they generally contain a conducting salt, e.g. LiPF_6 , to improve their conductivity. The methods for producing the systems described there include conventional casting, laminating and compression-molding processes.

[0022] U.S. Pat. No. 5 348 824 relates to a method for coating a positive electrode of an Li battery by melt extrusion of a solid polymer electrolyte which comprises a polymer as defined therein and an Li salt. EP-B 145 481 likewise describes a method for producing molded articles suitable for electrochemical cells, which involves melt-blending of a mixture of a conducting salt, an organic polymer and a plasticizer and producing a sheet from the melt, e.g. by extrusion. The electrochemical load-carrying capacity of the sheets thus obtained is inadequate, as a rule.

[0023] All these methods have in common that they are very complicated and/or result in molded articles which are unsatisfactory in terms of resistance to pressure and/or thermal stability.

[0024] It is therefore an object of the present invention to provide an improved method for producing such molded articles and to provide these molded articles per se which, owing to the production process, have a special microstructure and improved mechanical characteristics.

[0025] Owing to, in particular, the presence of a pigment III and the special process parameters used here, as defined hereinafter, molded articles are obtained which, when used as a solid electrolyte, separator or electrode, exhibit improved short-circuit withstand capability, enhanced resistance to pressure, in particular at elevated temperatures of above 120° C., and a greater porosity, all compared with the systems known hitherto, and in addition are capable of lasting suppression of Li dendrite formation. Furthermore, the presence of the pigment accounts for improved cycle stability and a higher current rating of an electrochemical cell. Another point is that if the preferentially used basic solids IIIa are employed, the acid formed during preparation of an electrochemical cell is scavenged or neutralized.

[0026] The invention therefore relates to a method for producing a molded article, preferably a sheet-type molded article, which method comprises the following stage:

[0027] I) Compounding and melt extrusion of a mixture I which comprises a blend II which contains: a) from 1 to 95 wt % of at least one pigment III having a primary particle size of from 5 nm to 20 mm which is selected from the group consisting of an electrochemically inert solid IIIa, a compound IIIb which during charging is able to give off lithium ions, and a compound IIIc which during charging is able to take up lithium ions, and a mixture of the solid IIIa with the compound IIIb or the compound IIIc,

[0028] b) from 5 to 99 wt % of at least one polymeric binder IV, and

[0029] c) from 0 to 200 wt %, based on the total amount of the components a) and b), of at least one plasticizer V,

[0030] wherein the proportion by weight of the blend II in the mixture I is from 1 to 100 wt %, and

[0031] wherein mixtures I comprising blends II containing, as the polymeric binder IV, a copolymer of vinylidene fluoride (VdF) and hexafluoropropylene (HFP) having an HFP content of from 8 to 25 wt % and, as the plasticizer V, a compound selected from the group consisting of dibutyl phthalate, dimethyl phthalate, diethyl phthalate, tris(butoxyethyl)phosphate, propylene carbonate, ethylene carbonate, trimethyl trimellitate and mixtures thereof are excluded.

[0032] It further relates to a method as defined hereinabove, wherein the pigment III is an electrochemically inert solid IIIa which is selected from the group consisting of an inorganic solid, preferably an inorganic basic solid, selected from the group consisting of oxides, mixed oxides, carbonates, silicates, sulfates, phosphates, amides, imides, nitrides and carbides of the elements of the Ist, IInd, IIIrd or IVth main group or the IVth subgroup of the Periodic Table of the Elements; a polymer selected from the group consisting of

polyethylene, polypropylene, polystyrene, poly(tetrafluoroethylene), poly(vinylidene fluoride), polyamides, polyimides; a solid dispersion containing a polymer of this type; glass powder, nano glass particles, such as Monosper® (company Merck), micro glass particles, such as Spherglass® (company Potters-Ballotini), nano whiskers and a mixture of two or more thereof, a molded article being obtained in the process which can be used as a solid electrolyte and/or a separator.

[0033] Examples to be mentioned are, in particular: oxides such as e.g. silicon dioxide, aluminum oxide, magnesium oxide or titanium dioxide, mixed oxides, for example of the elements silicon, calcium, aluminum, magnesium, titanium; silicates such as e.g. ladder-type silicates, inosilicates, phyllosilicates and tectosilicates; such as talcum, pyrophyllite, muscovite, phlogopite, amphiboles, nesosilicates, pyroxenes, sorosilicates, zeolithes, feldspar, glimpse, phyllosilicates; sulfates such as e.g. alkali metal sulfates and alkaline earth metal sulfates; carbonates, for example alkali metal carbonates and alkaline earth metal carbonates such as e.g. calcium carbonate, magnesium carbonate or barium carbonate or lithium carbonate, potassium carbonate or sodium carbonate; phosphates, for example apatites; amides; imides; nitrides; carbides; polymers such as e.g. polyethylene, polypropylene, polystyrene, polytetrafluoroethylene, poly(vinylidene fluoride), polyamides, polyimides or other thermoplastics, thermosets or microgels, cross-linked polymer particles such as Agfaperl® solid dispersions, in particular those containing the abovementioned polymers, and mixtures of two or more of the abovementioned solids.

[0034] Furthermore, as the inert solid IIIa, inorganic solids, which conduct Li-ions, preferably an inorganic basic solid, which conducts Li-ions, may be used according to the invention.

[0035] The following may be mentioned:

[0036] Lithium borates such as $\text{Li}_4\text{B}_6\text{O}_{11} \cdot x\text{H}_2\text{O}$, $\text{Li}_3(\text{BO}_2)_3$, $\text{Li}_2\text{B}_4\text{O}_7 \cdot x\text{H}_2\text{O}$, wherein x may be a number of from 0 to 20; lithium aluminates, such as $\text{Li}_2\text{O} \cdot \text{Al}_2\text{O}_3 \cdot \text{H}_2\text{O}$, $\text{Li}_2\text{Al}_2\text{O}_4$, LiAlO_2 ; lithium aluminosilicates, such as lithium containing zeolithes, feldspar, compounds of feldspar-type, phyllosilicates and inosilicates, and particularly $\text{LiAlSi}_2\text{O}_6$ (spodumen), $\text{LiAlSi}_4\text{O}_{10}$ (petullite), LiAlSiO_4 (eucryptite), glimmers, such as $\text{K}[\text{Li,Al}]_3[\text{AlSi}]_4\text{O}_{10}(\text{F}-\text{OH})_2$, $\text{K}[\text{Li,Al,Fe}]_3[\text{AlSi}]_4\text{O}_{10}(\text{F}-\text{OH})_2$; lithium zeolithes, particularly those in fiber-, sheet-, oder cube-form, particularly those having the general formula $\text{Li}_{2/z}\text{O} \cdot \text{Al}_2\text{O}_3 \cdot x\text{SiO}_2 \cdot y\text{H}_2\text{O}$ wherein z corresponds to the valancy, $x=1.8$ to about 12 and $y=0$ to about 8; lithium carbides, such as Li_2C_2 , Li_4C ; Li_3N ; lithium oxides and mixed oxides, such as LiAlO_2 , Li_2MnO_3 , Li_2O , Li_2O_2 , Li_2MnO_4 , Li_2TiO_3 ; Li_2NH ; LiNH_2 ; lithium phosphates, such as Li_3PO_4 , LiPO_3 , LiAlFPO_4 , $\text{LiAl}(\text{O}-\text{H})\text{PO}_4$, LiFePO_4 , LiMnPO_4 ; Li_2CO_3 ; lithium silicates of the ladder type, sheet type and tecto silicates, such as e.g. Li_2SiO_3 , Li_2SiO_4 and Li_6Si_2 ; lithium sulfate, such as Li_2SO_4 , LiHSO_4 , LiKSO_4 ; as well as the lithium compounds as mentioned under solid IIIb, under the proviso that when used as solid IIIa the presence of conductive black is excluded; and mixtures of two or more of the Li ion conducting solids as mentioned above.

[0037] Particularly suitable in this context are basic solids, where basic solids are to be understood as those whose mixture with a liquid diluent which contains water and itself has a pH of at most 7, has a higher pH than said diluent.

[0038] Advantageously, the solids should be very largely insoluble in the liquid used as an electrolyte and be electrochemically inert in the battery medium.

[0039] The invention further relates to a method, wherein the pigment III is a compound IIIb which, during charging, is able to give off lithium ions and which is selected from the group consisting of LiCoO_2 , LiNiO_2 , $\text{LiNi}_x\text{Co}_y\text{O}_2$, $\text{LiNi}_x\text{Co}_y\text{Al}_z\text{O}_2$ ($0 < x, y, z \leq 1$), Li_xMnO_2 ($0 < x \leq 1$), $\text{Li}_x\text{Mn}_2\text{O}_4$ ($0 < x \leq 2$), Li_xMoO_2 ($0 < x \leq 2$), Li_xMnO_3 ($0 < x \leq 1$), Li_xMnO_2 ($0 < x \leq 2$), $\text{Li}_x\text{Mn}_2\text{O}_4$ ($0 < x \leq 2$), $\text{Li}_x\text{V}_2\text{O}_4$ ($0 < x \leq 2.5$), $\text{Li}_x\text{V}_2\text{O}_3$ ($0 < x \leq 3.5$), Li_xVO_2 ($0 < x \leq 1$), Li_xWO_2 ($0 < x \leq 1$), Li_xWO_3 ($0 < x \leq 1$), Li_xTiO_2 ($0 < x \leq 1$), $\text{Li}_x\text{Ti}_2\text{O}_4$ ($0 < x \leq 2$), Li_xRuO_2 ($0 < x \leq 1$), $\text{Li}_x\text{Fe}_2\text{O}_3$ ($0 < x \leq 2$), $\text{Li}_x\text{Fe}_3\text{O}_4$ ($0 < x \leq 2$), $\text{Li}_x\text{Cr}_2\text{O}_3$ ($0 < x \leq 3$), $\text{Li}_x\text{Cr}_3\text{O}_4$ ($0 < x \leq 3.8$), $\text{Li}_x\text{V}_3\text{S}_5$ ($0 < x \leq 1.8$), $\text{Li}_x\text{Ta}_2\text{S}_2$ ($0 < x \leq 1$), Li_xFeS ($0 < x \leq 1$), Li_xFeS_2 ($0 < x \leq 1$), Li_xNbS_2 ($0 < x \leq 2.4$), Li_xMoS_2 ($0 < x \leq 3$), Li_xTiS_2 ($0 < x \leq 2$), Li_xZrS_2 ($0 < x \leq 2$), Li_xNbSe_2 ($0 < x \leq 3$), Li_xVSe_2 ($0 < x \leq 1$), Li_xNiPS_2 ($0 < x \leq 1.5$), Li_xFePS_2 ($0 < x \leq 1.5$), $\text{LiNi}_x\text{B}_{1-x}\text{O}_2$ ($0 < x < 1$), $\text{LiNi}_x\text{Al}_{1-x}\text{O}_2$ ($0 < x < 1$), $\text{LiNi}_x\text{Mg}_{1-x}\text{O}_2$ ($0 < x < 1$), $\text{LiNi}_x\text{Co}_{1-x}\text{VO}_4$ ($1 \geq x \geq 0$), $\text{LiNi}_x\text{Co}_y\text{Mn}_z\text{O}_2$ ($x+y+z=1$), LiFeO_2 , LiCrTiO_4 , $\text{Li}_a\text{M}_b\text{L}_c\text{O}_d$ ($1.15 \geq a > 0$; $1.3 \geq b + c \geq 0.8$; $2.5 \geq d \geq 1.7$; $M=\text{Ni, Co, Mn}$; $L=\text{Ti, Mn, Cu, Zn}$, alkaline earth metals, $\text{LiCu}_x\text{Cu}_y\text{Mn}_{(2-(x+y))}\text{O}_4$ ($2 > x + y \geq 0$), LiCrTiO_4 , $\text{LiGa}_x\text{Mn}_{2-x}\text{O}_4$ ($0.1 \geq x \geq 0$), polycarbon-sulfides of the general structure: $-\text{[C(S}_x\text{)]}_n-$, V_2O_5 , a mixture of two or more thereof, and a mixture of the compound IIIb with the solid IIIa; and the mixture I additionally contains from 0.1 to 20 wt %, based on the blend II, of conductive black, a molded article being obtained which can be used, in particular, as a cathode.

[0040] Moreover, the invention relates to a method, wherein the pigment III is a compound IIIc which, during charging, is able to take up lithium ions and which is selected from the group consisting of lithium, a lithium-containing metal alloy, micronized carbon black, natural and synthetic graphite, synthetically graphitized carbon dust, a carbon fiber, titanium oxide, zinc oxide, tin oxide, molybdenum oxide, tungsten oxide, titanium carbonate, molybdenum carbonate, zinc carbonate, $\text{Li}_x\text{M}_y\text{SiO}_z$ ($1 > x \geq 0$, $1 > y \geq 0$, $z > 0$), Sn_2BPO_4 , conjugated polymers such as polypyrroles, polyanilines, polyacetylenes, polyphenylenes, lithium metal compounds Li_xM , such as those, wherein $M=\text{Sn, Bi, Sb, Zn, Cd, Pb}$ and $5 \geq x \geq 0$; Li-Sn-Cd , CdO , PbO , a mixture of two or more thereof, and a mixture of the compound IIIc with the solid IIIa; and the mixture I additionally contains up to 20 wt %, based on the blend II, of conductive black, a molded article being obtained which can be used, in particular, as an anode.

[0041] Particularly suitable are pigments III having a primary particle size of from 5 nm to 20 mm, preferably from 0.01 to 10 mm and in particular from 0.1 to 5 mm, the specified particle sizes being determined by electron microscopy. The melting point of the pigments is preferably above the normal operating temperature for the electrochemical cell, melting points of above 120° C., in particular of above 150° C. having proved particularly beneficial.

[0042] In this context the pigments, in terms of their external shape, can be symmetrical, i.e. have a size ratio height:width:length (aspect ratio) of approximately 1 and be present in the form of spheres, granules, approximately round structures, but also in the form of any type of polyhedron such as e.g. cuboids, tetrahedra, hexahedra,

octahedra or as a bipyramid or be distorted or asymmetrical, i.e. have a size ratio height:width:length (aspect ratio) different from 1 and be present e.g. as needles, asymmetric tetrahedra, asymmetric bipyramids, asymmetric hexahedra or octahedra, laminae, disks or fibrous structures. Insofar as the solids are present as asymmetric particles, the above-specified upper limit for the primary particle size in each case refers to the shortest axis.

[0043] In the course of the production of the molded articles which can be used as a cathode or anode, the conductive black, if present, is preferably added to the blend II in the form of a masterbatch. The masterbatch is a composition which contains from 20 to 50 wt % of conductive black, from 5 to 30 wt % of polymeric binder IV and from 30 to 75 wt % of plasticizer IV, the amount and composition chosen of the masterbatch being such that, based on the blend II, the amount of conducting salt added in total does not exceed 20 wt %. The masterbatch is preferably prepared by compounding and melt extrusion of the abovementioned components.

[0044] The blends II should comprise, according to the invention, from 1 to 95 wt %, preferably from 25 to 90 wt % and in particular from 30 to 70 wt % of a pigment III and from 5 to 99 wt %, preferably from 10 to 75 wt % and in particular from 30 to 70 wt % of a polymeric binder IV, where the polymeric binder should advantageously have a mean molecular weight (number average) of from 5000 to 100,000,000, preferably from 50,000 to 8,000,000.

[0045] The following additional feedstocks are used in producing the molded article or in the mixture I used or the blend II:

[0046] Used as the polymeric binders IV are thermoplastic and ion-conductive polymers, examples to be mentioned in particular being:

[0047] 1) Homopolymers, block polymers or copolymers IVa (polymers IVa) which can be obtained by polymerization of

[0048] b1) from 5 to 100 wt %, based on the polymer IVa, of a condensation product VI of

[0049] α) at least one compound VII which is able to react with a carboxylic acid or a sulfonic acid or a derivative or a mixture of two or more of these, and

[0050] β) at least 1 mol per mole of the compound VII of a carboxylic acid or sulfonic acid VIII which has at least one free-radical polymerizable functional group or of a derivative thereof or of a mixture of two or more of these and

[0051] b2) from 0 to 95 wt %, based on the polymer IVa, of a further compound IX having a mean molecular weight (number average) of at least 5000 comprising polyether segments in the main chain or a side chain.

[0052] The polymer IVa is preferably obtainable via

[0053] b 1) from 5 to 100 wt %, based on the polymer IVa, of a condensation product VI of

[0054] α) a polyhydric alcohol VII which contains carbon atoms and oxygen atoms in the main chain, and

[0055] β) at least 1 mol per mole of the polyhydric alcohol VII of an α , β -unsaturated carboxylic acid VII, and

[0056] b2) from 0 to 95 wt %, based on the polymer IVa, of a further compound IX having a mean molecular weight (number average) of at least 5000 comprising polyether segments in the main chain or a side chain.

[0057] Suitable, in principle, as the compound VII which is capable of reacting with a carboxylic acid or a sulfonic acid VII or a derivative or a mixture of two or more thereof are all compounds which satisfy this criterion.

[0058] The compound VII is preferentially selected from the group consisting of a mono- or polyhydric alcohol which in its main chain solely comprises carbon atoms; a mono- or polyhydric alcohol which in its main chain, in addition to at least two carbon atoms, has at least one atom which is selected from the group consisting of oxygen, phosphorus and nitrogen; a silicon-containing compound; an amine having at least one primary amino group; an amine having at least one secondary amino group; an amino alcohol; a mono- or polyhydric thiol; a compound having at least one thiol and at least one hydroxyl group; and a mixture of two or more of these.

[0059] Among these, in turn, compounds VII are preferred which have two or more functional groups which are able to react with the carboxylic acid or sulfonic acid.

[0060] If compounds VII are used which as the functional group contain amino groups, preference is given to the use of those having secondary amino groups, so that after the condensation/cross-linking either no free NH groups or only small amounts of these are present in the mixture Ia.

[0061] To be mentioned individually as preferred compounds are:

[0062] mono- or polyhydric alcohols whose main chain consists exclusively of carbon atoms and which have from 1 to 20, preferably from 2 to 20 and in particular from 2 to 10 alcoholic OH groups, in particular dihydric, trihydric and tetrahydric alcohols, preferably having from 2 to 20 carbon atoms, such as e.g. ethylene glycol, propane-1,2- or -1,3-diol, butane-1,2- or -1,3-diol, butene-1,4- or butyne-1,4-diol, hexane-1,6-diol, neopentyl glycol, dodecane-1,2-diol, glycerol, trimethylolpropane, pentaerythritol or sugar alcohols, hydroquinone, novolak, bisphenol A, an alternative option, however, as follows from the above definition, being the use of monohydric alcohols such as e.g. methanol, ethanol, propanol, n-, sec- or t-butanol etc.; furthermore it is also possible to employ polyhydroxyolefins, preferably those having two terminal hydroxyl groups, such as e.g. α,ω -dihydroxybutadiene;

[0063] polyester polyols such as those known e.g. from Ullmann's *Encyklopädie der technischen Chemie*, 4th edition, vol. 19, pp. 62-65 and obtainable, for example, by the reaction of dihydric alcohols with polybasic, preferably dibasic polycarboxylic acids; mono- or polyhydric alcohols which in their main chain, in addition to at least two carbon atoms, contain at least one oxygen atom, preferably polyether alcohols such as e.g. polymerization products of alkylene epoxides, for example isobutylene oxide, propylene oxide, ethylene oxide, 1,2-epoxybutane, 1,2-epoxypentane,

1,2-epoxyhexane, tetrahydrofuran, styrene oxide, an additional option being the use of polyether alcohols modified at their terminal groups, such as e.g. polyether alcohols modified by means of NH_2 terminal groups; these alcohols preferably have a molecular weight (number average) of from 100 to 5000, more preferably from 200 to 1000 and in particular from 300 to 800; compounds of this type are known per se and are commercially available, for example, under the brands Pluriol® or Pluronic® (BASF Aktiengesellschaft);

[0064] alcohols as defined above, in which some or all of the carbon atoms have been replaced by silicon, a particular option in this context being the use of polysiloxanes or alkylene oxide/siloxane copolymers or mixtures of polyether alcohols and polysiloxanes, as described, for example, in EP-B 581 296 and EP-A 525 728, what was said above likewise applying to the molecular weight of these alcohols;

[0065] alcohols as defined above, in particular polyether alcohols in which some or all the oxygen atoms have been replaced by sulfur atoms, what was said above likewise applying to the molecular weight of these alcohols;

[0066] mono- or polyhydric alcohols which, in their main chain, in addition to at least two carbon atoms contain at least one phosphorus atom or at least one nitrogen atom such as e.g. diethanolamine, triethanolamine;

[0067] lactones which are derived from compounds of the general formula $\text{HO}-(\text{CH}_2)_z-\text{COOH}$, where z is a number from 1 to 20, such as e.g. ϵ -caprolactone, β -propiolactone, γ -butyrolactone or methyl- ϵ -caprolactone;

[0068] a silicon-containing compound such as e.g. di- or trichlorosilane, phenyltrichlorosilane, diphenyldichlorosilane, dimethylvinylchlorosilane; silanols such as e.g. trimethylsilanol; an amine having at least one primary and/or secondary amino group, such as e.g. butylamine, 2-ethylhexylamine, ethylenediamine, hexamethylenediamine, diethylenetriamine, tetraethylenepentamine, pentaethylenehexamine, aniline, phenylenediamine;

[0069] polyetherdiamines such as e.g. 4,7-dioxadecane-1,10-diamine, 4,11-dioxatetradecane-1,14-diamine;

[0070] a mono- or polyhydric thiol such as e.g. aliphatic thiols such as e.g. methanethiol, ethanethiol, cyclohexanethiol, dodecanethiol; aromatic thiols such as e.g. thiophenol, 4-chlorothiophenol, 2-mercaptoaniline;

[0071] a compound having at least one thiol and at least one hydroxyl group, such as e.g. 4-hydroxythiophenol and monothio derivatives of the above-defined polyhydric alcohols;

[0072] amino alcohols such as e.g. ethanolamine, N-methyl-ethanolamine, N-ethylethanolamine, N-butylethanolamine, 2-amino-1-propanol, 2-amino-1-phenylethanol; mono- or polyaminopolyols having more than two aliphatically bound hydroxyl groups, such as e.g. tris(hydroxymethyl)methylamine, glucamine, N,N'-bis-(2-hydroxyethyl)ethylenediamine, and mixtures of these.

[0073] It is also possible to use mixtures of two or more of the above-described compounds VII.

[0074] The abovementioned compounds VII are condensed, according to the invention, with a carboxylic acid or sulfonic acid VIII which has at least one free-radical poly-

merizable functional group or with a derivative thereof or a mixture of two or more of these, at least one, preferably all of the free groups capable of condensation within the compounds VII being condensed with the compound VIII.

[0075] Suitable in principle as the carboxylic acid or sulfonic acid VIII within the scope of the present invention are all those carboxylic and sulfonic acids which have at least one free-radical polymerizable functional group, as are their derivatives. In this context, the term "derivatives" as used herein comprises both compounds derived from a carboxylic or sulfonic acid which has been modified at the acid function (such as e.g. esters, acid halides or acid anhydrides) and compounds derived from a carboxylic or sulfonic acid which has been modified on the carbon skeleton of the carboxylic or sulfonic acid, such as e.g. halo-carboxylic or halosulfonic acids.

[0076] Particular examples to be mentioned of compound VIII are:

[0077] α,β -unsaturated carboxylic acids or α,γ -unsaturated carboxylic acids or derivatives thereof.

[0078] Particularly suitable α,β -unsaturated carboxylic acids in this context are those of the formula

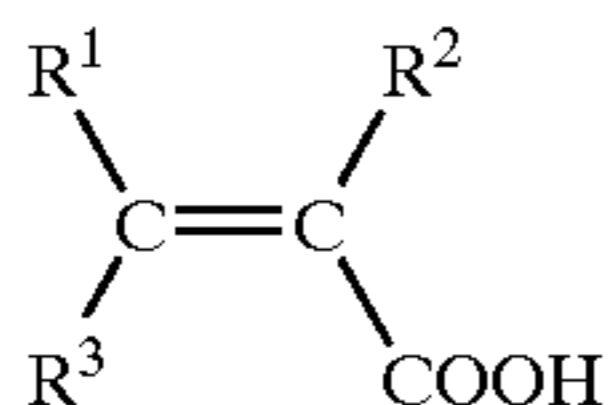

[0079] where R^1 , R^2 and R^3 are hydrogen or C_1 - C_4 -alkyl, among which in turn acrylic acid and methacrylic acid are preferred; also expediently usable are cinnamic acid, maleic acid, fumaric acid, itaconic acid or p-vinylbenzoic acid and derivatives of these, such as e.g. anhydrides such as e.g. maleic or itaconic anhydride;

[0080] halides, in particular chlorides, such as e.g. acryloyl or methacryloyl chloride; esters such as e.g. (cyclo)alkyl (meth)acrylates having up to 20 C atoms in the alkyl radical, such as e.g. methyl (meth)acrylate, ethyl (meth)acrylate, propyl-(meth)acrylate, butyl (meth)acrylate, hexyl (meth)acrylate, 2-ethylhexyl (meth)acrylate, stearyl (meth)acrylate, lauryl (meth)acrylate, cyclohexyl (meth)acrylate, benzyl (meth)acrylate, trifluoromethyl (meth)acrylate, hexafluoropropyl (meth)acrylate, tetrafluoropropyl (meth)acrylate, polypropylene-glycol mono(meth)acrylates, polyethylene mono(meth)acrylates, poly(meth)acrylates of polyhydric alcohols, such as e.g. glycerol di(meth)acrylate, trimethylolpropane di(meth)acrylate, pentaerythritol di- or tri(meth)acrylate, diethylene glycol bis(mono-(2-acryloxy)ethyl)carbonate, poly(meth)acrylates of alcohols which themselves in turn have a free-radical polymerizable group, such as e.g. esters from (meth)acrylic acid and vinyl and/or allyl alcohol;

[0081] vinyl esters of other aliphatic or aromatic carboxylic acids, such as e.g. vinyl acetate, vinyl propionate, vinyl butanoate, vinyl hexanoate, vinyl octanoate, vinyl decanoate, vinyl stearate, vinyl palmitate, vinyl crotonate, divinyl adipate, divinyl sebacate, vinyl 2-ethylhexanoate, vinyl trifluoroacetate;

[0082] allyl esters of other aliphatic or aromatic carboxylic acids, such as e.g. allyl acetate, allyl propionate, allyl

butanoate, allyl hexanoate, allyl octanoate, allyl decanoate, allyl stearate, allyl palmitate, allyl crotonate, allyl salicylate, allyl lactate, diallyl oxalate, allyl stearate, allyl succinate, diallyl glutarate, diallyl adipate, diallyl pimelate, allyl cinnamate, diallyl maleate, diallyl phthalate, diallyl isophthalate, triallyl benzene-1,3,5-tricarboxylate, allyl fluoroacetate, allyl perfluorobutyrate, allyl perfluorooctanoate;

[0083] β,γ -unsaturated carboxylic acids and derivatives thereof, such as e.g. vinylacetic acid, 2-methylvinylacetic acid, isobutyl 3-butenate, allyl 3-butenate, allyl 2-hydroxy-3-butenate, diketene;

[0084] sulfonic acids such as, e.g. vinylsulfonic acid, allyl- and methallylsulfonic acid, and their esters and halides, vinyl benzenesulfonate, 4-vinylbenzene-sulfonamide.

[0085] It is also possible for mixtures of two or more of the above-described carboxylic and/or sulfonic acids to be used.

[0086] The polymer IVa can be obtained by the reaction of from 5 to 100 wt %, preferably from 30 to 70 wt %, based on the polymer IVa, of a condensation product VI and from 0 to 95 wt %, in particular from 30 to 70 wt %, based on the polymer IVa, of a compound IX.

[0087] Homopolymers, block polymers or copolymers IVb (polymers IVb), obtainable by polymerization of

[0088] b1) from 5 to 75 wt %, based on the polymer IVb, of an unsaturated compound X which is capable of free-radical polymerization and differs from the above carboxylic acid or the sulfonic acid or a derivative thereof, or of a mixture of two or more of these and

[0089] b2) from 25 to 95 wt %, based on the polymer IVb, of a further compound IX, having a mean molecular weight (number average) of at least 5000 and comprising polyether segments in the main chain or a side chain as a polymeric binder.

[0090] Examples to be mentioned in particular of the compound X which can be used for the preparation of the polymer IVb and is capable of free-radical polymerization include the following:

[0091] olefinic hydrocarbons such as e.g. ethylene, propylene, butylene, isobutene, hexene or higher homologs and vinyl cyclohexane; (meth)acrylonitrile;

[0092] halogen-containing olefinic compounds such as e.g. vinylidene fluoride, vinylidene chloride, vinyl fluoride, vinyl chloride, hexafluoropropene, trifluoropropene, 1,2-dichloroethylene, 1,2-difluoroethylene and tetrafluoroethylene;

[0093] vinyl alcohol, vinyl acetate, N-vinylpyrrolidone, N-vinylimidazole, vinylformamide;

[0094] phosphonitrile chlorides such as e.g. phosphonitrile dichloride, hexachloro(triphosphazene), and their derivatives partially or completely substituted by alkoxy, phenoxy, amino and fluoroalkoxy groups, i.e. compounds which can be polymerized to give polyphosphazenes; aromatic, olefinic compounds such as e.g. styrene, α -methylstyrene; vinyl ethers such as e.g. methyl, ethyl, propyl, isopropyl, butyl, isobutyl, hexyl, octyl, decyl, dodecyl, 2-ethylhexyl, cyclohexyl, benzyl, trifluoromethyl, hexafluoropropyl, tetrafluoropropyl vinyl ether.

[0095] Of course it is also possible to employ mixtures of the abovementioned compounds X, in which case copolymers are then formed which, depending on the preparation route, contain the monomers in random distribution or result in block copolymers.

[0096] These compounds X, like the condensation products VI, are polymerized in a conventional manner well known to those skilled in the art, preferably by free-radical polymerization, the molecular weights obtained being subject to the same points as made below regarding the compound IX.

[0097] Potentially suitable, in the first instance, for compound IX are compounds having a mean molecular weight (number average) of at least 5000, preferably from 5000 to 20,000,000, in particular from 100,000 to 6,000,000, which are able to solvate lithium cations and to act as a binder. Examples of suitable compounds IX include polyethers and copolymers which comprise at least 30 wt % of the following structural unit, based on the total weight of the compound IX:

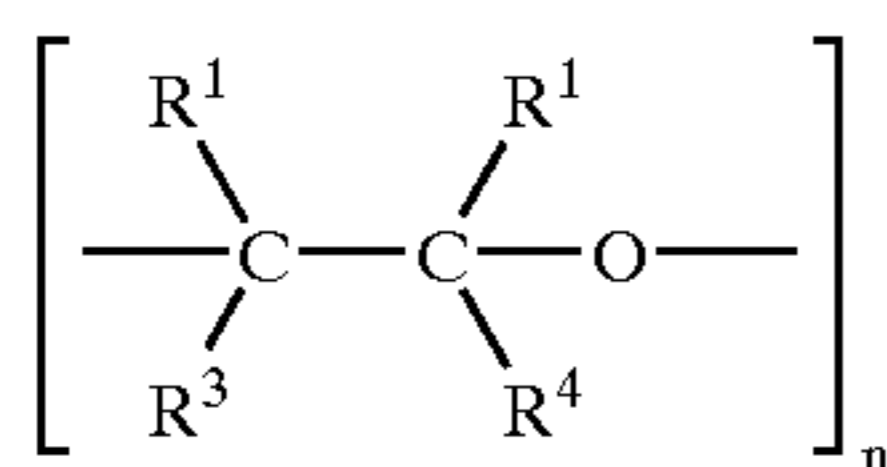

[0098] where R¹, R², R³ and R⁴ are aryl, alkyl, preferably methyl, or hydrogen, may be identical or different and may include hetero atoms such as oxygen, nitrogen, sulfur or silicon.

[0099] Such compounds are described, for example, in: M. B. Armand et al., *Fast Ion Transport in Solids*, Elsevier, New York, 1979, pp. 131-136, or in FR-A 7832976.

[0100] The compound IX may alternatively consist of mixtures of such compounds.

[0101] The polymer IVb can be obtained by the reaction of from 5 to 75 wt %, preferably from 30 to 70 wt %, based on the polymer IVb, of a compound X and from 25 to 95 wt %, in particular from 30 to 70 wt %, based on the polymer IVb, of a compound IX;

[0102] 3) Polycarbonates such as e.g. polyethylene carbonate, polypropylene carbonate, polybutadiene carbonate, polyvinylidene carbonate.

[0103] 4) Homopolymers, block polymers and copolymers prepared from

[0104] a) olefinic hydrocarbons such as e.g. ethylene, propylene, butylene, isobutene, propene, hexene or higher homologs, butadiene, cyclopentene, cyclohexene, norbornene, vinylcyclohexane, 1,3-pentadiene, 1,3-, 1,4-, 1,5-hexadiene, isoprene, vinyl norbornene;

[0105] b) aromatic hydrocarbons such as e.g. styrene and methylstyrene;

[0106] c) acrylic acid or methacrylic acid ester such as methyl, ethyl, propyl, isopropyl, butyl, isobutyl, hexyl, octyl, decyl, dodecyl, 2-ethylhexyl, cyclo-

hexyl, benzyl, trifluoromethyl, hexafluoropropyl, tetrafluoropropyl acrylate or methacrylate;

[0107] d) acrylonitrile, methacrylonitrile, N-methylpyrrolidone, N-vinylimidazole, vinyl acetate;

[0108] e) vinyl ethers such as e.g. methyl, ethyl, propyl, isopropyl, butyl, isobutyl, hexyl, octyl, decyl, dodecyl, 2-ethylhexyl, cyclohexyl, benzyl, trifluoromethyl, hexafluoropropyl, tetrafluoropropyl vinyl ether;

[0109] f) halogen-containing olefinic compounds such as vinyl chloride, vinyl fluoride, vinylidene fluoride, vinylidene chloride, hexafluoropropene, trifluoropropene, 1,2-dichloroethene, 1,2-difluoroethene, tetrafluoroethene.

[0110] g) 2-vinylpyridine, 4-vinylpyridine, vinylene carbonate.

[0111] Within the preparation of the above mentioned polymers, controlling compounds, such as e.g. mercaptane may be used if desired or regarded as being necessary.

[0112] 5) Polyurethanes, for example obtainable by the reaction of

[0113] a) organic diisocyanates having from 6 to 30 C atoms, such as e.g. aliphatic acyclic diisocyanates such as e.g. 1,5-hexamethylene diisocyanate and 1,6-hexamethylene diisocyanate, aliphatic cyclic diisocyanates such as e.g. 1,4-cyclohexylene diisocyanate, dicyclohexylmethane diisocyanate and isophorone diisocyanate or aromatic diisocyanates such as e.g. 2,4-diisocyanatotoluene, 2,6-diisocyanatotoluene, m-tetramethylxylene diisocyanate, p-tetramethylxylene diisocyanate, 1,5-diisocyanatotetrahydronaphthalene and 4,4'-diisocyanatodiphenylmethane or mixtures of such compounds with

[0114] b) polyhydric alcohols such as e.g. polyesterols, polyetherols and diols.

[0115] The polyesterols are expediently predominantly linear polymers having terminal OH groups, preferably those having two or three, in particular two OH terminal groups. The acid value of the polyesterols is less than 10 and preferably less than 3. The polyesterols can be prepared in a simple manner by esterification of aliphatic or aromatic dicarboxylic acids having from 4 to 15 C atoms, preferably from 4 to 6 C atoms, with glycols, preferably glycols having from 2 to 25 C atoms, or by polymerization of lactones having from 3 to 20 C atoms. Examples of dicarboxylic acids which can be used include glutaric acid, pimelic acid, suberic acid, sebacic acid, dodecanoic acid and preferably adipic acid and succinic acid. Suitable aromatic dicarboxylic acids are terephthalic acid, isophthalic acid, phthalic acid or mixtures of these dicarboxylic acids with other dicarboxylic acids, e.g. diphenic acid, sebacic acid, succinic acid and adipic acid. The dicarboxylic acids can be used individually or as mixtures. For the purpose of preparing the polyesterols it may be advantageous for the dicarboxylic acids to be replaced by the corresponding acid derivatives such as carboxylic acid anhydrides or carboxylic acid chlorides. Examples of suitable glycols are diethylene glycol, 1,5-pentanediol, 1,10-decanediol and 2,2,4-trimethylpentanediol-1,5. Preferentially used are 1,2-ethanediol, 1,3-

propanediol, 2-methyl-1,3-propanediol, 1,4-butanediol, 1,6-hexanediol, 2,2-dimethylpropanediol-1,3, 1,4-dimethylcyclohexane, 1,4-diethanolicyclohexane and ethoxylated or propoxylated products of 2,2-bis-(4-hydroxyphenylene)propane (bisphenol A). Depending on the desired properties of the polyurethanes, the polyols may be used on their own or as a mixture in various quantitative proportions. Suitable as lactones for the preparation of the polyesterols are, e.g. α,α -dimethyl- β -propiolactone, γ -butyrolactone and preferably ϵ -caprolactone.

[0116] The polyetherols are essentially linear substances which have terminal hydroxyl groups and contain ether bonds. Suitable polyetherols can readily be prepared by polymerization of cyclic ethers such as tetrahydrofuran or by one or more alkylene oxides having from 2 to 4 C atoms in the alkylene radical being reacted with a starter molecule which contains two active hydrogen atoms bound in the alkylene radical. Examples to be mentioned of alkylene oxides include ethylene oxide, 1,2-propylene oxide, epichlorohydrin, 1,2-butylene oxide, 2,3-butylene oxide. The alkylene oxides can be used singly, alternately in succession or as a mixture. Examples of potentially suitable starter molecules include water, glycols such as ethylene glycol, propylene glycol, 4-butanediol and 1,6-hexanediol, amines such as ethylenediamine, hexamethylenediamine and 4,4'-diaminodiphenylmethane and amino alcohols such as ethanolamine. Suitable polyesterols and polyetherols and their preparation are described, for example, in EP-B 416 386, suitable polycarbonate diols, preferably those based on 1,6-hexanediol, and their preparation are described, for example, in U.S. Pat. No. 4,131,731.

[0117] Potentially advantageous, in amounts of up to 30 wt %, based on the total mass of the alcohols, are aliphatic diols having from 2 to 20, preferably from 2 to 10 C atoms, such as 1,2-ethanediol, 1,3-propanediol, 1,4-butanediol, 1,6-hexanediol, 1,5-pentanediol, 1,10-decanediol, 2-methyl-1,3-propanediol, 2,2-dimethyl-1,3-propanediol, 2-methyl-2-butyl-1,3-propanediol, 2,2-dimethyl-1,4-butanediol, 1,4-dimethylcyclohexane, neopentyl glycol hydroxypivalate, diethylene glycol, triethylene glycol and methyl diethanolamine or aromatic-aliphatic or aromatic-cycloaliphatic diols having from 8 to 30 C atoms, potentially suitable aromatic structures being heterocyclic ring systems or preferably isocyclic ring systems such as naphthalene and in particular benzene derivatives such as bisphenol A, doubly symmetrically ethoxylated bisphenol A, doubly symmetrically propoxylated bisphenol A, bisphenol A derivatives or bisphenol F derivatives ethoxylated or propoxylated to a higher degree, and mixtures of such compounds.

[0118] Potentially advantageous in amounts of up to 5 wt %, based on the total mass of the alcohols, are aliphatic triols having from 3 to 15, preferably from 3 to 10 C atoms, such as trimethylolpropane or glycerol, the reaction product of such compounds with ethylene oxide and/or propylene oxide and mixtures of such compounds.

[0119] The polyhydric alcohols may carry functional groups, for example neutral groups such as siloxane groups, basic groups such as, in particular, tertiary amino groups or acidic groups or their salts, or groups which are readily converted into acidic groups, these functional groups being introduced via a polyhydric alcohol. Preferentially, diol components carrying such groups can be used, such as

N-methyldiethanolamine, diethyl N,N-bis(hydroxyethyl)-aminomethylphosphonate or 3-sulfopropyl N,N-bis(hydroxyethyl)-2-aminoacetate or dicarboxylic acids which carry such groups and can be used for the preparation of polyesterols, such as 5-sulfoisophthalic acid.

[0120] Acidic groups include, in particular, the phosphoric acid, phosphonic acid, sulfuric acid, sulfonic acid, carboxyl or ammonium group.

[0121] Examples of groups which are readily converted into acidic groups include the ester group or salts, preferably of the alkali metals such as lithium, sodium or potassium.

[0122] 6) The above-described polyesterols per se, in which case care should be taken to ensure that molecular weights in the range of from 10,000 to 2,000,000, preferably from 50,000 to 1,000,000 are obtained.

[0123] 7) Polyamines, polysiloxanes and polyphosphazenes, in particular of the type already discussed in the context of the description of the polymer IVb.

[0124] 8) Polyetherols such as those described e.g. in the above discussion of the polymer IVa as compound IX or in the discussion of the polyurethanes.

[0125] Suitable for use as the plasticizer V are aprotic solvents, preferably those which solvate Li ions, such as e.g. dimethyl carbonate, ethyl methyl carbonate, diethyl carbonate, dipropyl carbonate, diisopropyl carbonate, dibutyl carbonate, propylene carbonate; cyclic carbonates of the formula $C_nH_{n+1}O_y$, $n=2$ to 30, $m=3$ to 7, such as ethylene carbonate, 1,2-propylene carbonate, 1,3-propylene carbonate, 1,2-butylene carbonate, 1,3-butylene carbonate, 1,4-butylene carbonate, 2,3-butylene carbonate; oligoalkylene oxides such as e.g. dibutyl ether, di-t-butyl ether, dipentyl ether, dihexyl ether, diheptyl ether, dioctyl ether, dinonyl ether, didecyl ether, didoecyl ether, ethylene glycol dimethyl ether, ethylene glycol diethyl ether, 1-t-butoxy-2-methoxyethane, 1-t-butoxy-1-ethoxyethane, 1,2-dimethoxypropane, 2-methoxyethyl ether, 2-ethoxyethyl ether, diethylene glycol dibutyl ether, dimethylene glycol t-butyl methyl ether, triethylene glycol dimethyl ether, tetraethylene glycol dimethyl ether, γ -butyrolactone, dimethylformamide; dimethyl- γ -butyrolactone, diethyl- γ -butyrolactone, γ -valerolactone, 4,5-dimethyl-1,3-dioxolane-2-one, 4,4-dimethyl-1,3-dioxolane-2-one, 4-ethyl-1,3-dioxolane-2-one, 4-methyl-5-ethyl-1,3-dioxolane-2-one, 4,5-diethyl-1,3-dioxolane-2-one, 4,4-diethyl-1,3-dioxolane-2-one, 1,3-dioxane-2-one, 4-methyl-1,3-dioxane-2-one, 5-methyl-1,3-dioxane-2-one, 4,4-dimethyl-1,3-dioxane-2-one, 5,5-dimethyl-1,3-dioxane-2-one, 4,6-dimethyl-1,3-dioxane-2-one, 4,4,6-trimethyl-1,3-dioxane-2-one, 5,5-diethyl-1,3-dioxane-2-one, spiro-(1,3-oxa-2-cyclohexanone)-5',5',1',3'-oxacyclohexane; 4-dimethylethoxysilyl-1,2-butylene carbonate; diester of carboxylic acids of the formula $R^1OCOOR^2OCOOR^3$ ($R^1, R^2, R^3=C_1-C_{20}$ -hydrocarbons), organic ester of the formula R^1-COOR^2 (R^1 and $R^2=C_1-C_{20}$ -hydrocarbons), hydrocarbons of the general formula C_nH_{2n+2} with $7 < n < 50$; organic phosphorus compounds, in particular phosphates and phosphonates such as e.g. trimethyl phosphate, triethyl phosphate, tripropyl phosphate, tributyl phosphate, triisobutyl phosphate, tripentyl phosphate, trihexyl phosphate, trioctyl phosphate, tris(2-ethylhexyl) phosphate, tridecyl phosphate, diethyl n-butyl phosphate, tris(butoxyethyl) phosphate, tris(2-methoxyethyl) phosphate, tris(tetrahydro-

furyl) phosphate, tris(1H,1H,5H-octafluoropentyl) phosphate, tris(1H,1H-trifluoroethyl) phosphate, tris(2-(diethylamino)ethyl) phosphate, tris(methoxyethoxyethyl)phosphate, tris(methoxyethoxy)trifluorophosphazene, tris(methoxycarbonyloxyethyl)phosphate, diethyl ethylphosphonate, dipropyl propylphosphonate, dibutyl butylphosphonate, dihexyl hexylphosphonate, dioctyl octylphosphonate, ethyl dimethyl phosphonoacetate, methyl diethyl phosphonoacetate, triethyl phosphonoacetate, dimethyl (2-oxopropyl)phosphonate, diethyl (2-oxopropyl) phosphonate, dipropyl (2-oxopropyl) phosphonate, ethyl diethoxyphosphinylformate, trimethyl phosphonoacetate, triethyl phosphonoacetate, tripropyl phosphonoacetate, tributyl phosphonoacetate; organic sulfur compounds such as e.g. sulfates, sulfonates, sulfoxides, sulfones and sulfites, such as e.g. dimethyl sulfite, diethyl sulfite, glycol sulfite, dimethyl sulfone, diethyl sulfone, dipropyl sulfone, dibutyl sulfone, tetramethylene sulfone, methylsulfolane, dimethyl sulfoxide, diethyl sulfoxide, dipropyl sulfoxide, dibutyl sulfoxide, tetramethylene sulfoxide, ethyl methanesulfonate, 1,4-butanediol bis-(methanesulfonate), diethyl sulfate, dipropyl sulfate, dibutyl sulfate, dihexyl sulfate, dioctyl sulfate, SO₂ClF;

[0126] nitriles, such as e.g. acrylonitrile;

[0127] dispersants, in particular having a surfactant structure;

[0128] and mixtures of these.

[0129] Furthermore, in general suitable organic compounds may be used as plasticizer V such as e.g. acids C_nH_xF_y, wherein n=5 to 30, x,y=2n+2; ethers C_nH_xF_yO_z, wherein n=5 to 30, x+y=2n+2, z=1 to 14; ketones C_nH_xF_yO, wherein n=5 to 30, x+y=2n; esters C_nH_xF_yO₂, wherein n=5 to 30, x+y=2n; carbonates C_nH_xF_yO₃, wherein n=5 to 30, x+y=2n; lactones C_nH_xF_yO₂, wherein n=5 to 20, x+y=2n-2; cyclic carbonates C_nH_xF_yO₃, wherein n=5 to 20, x+y=2n-2; and boric acid esters wherein R¹-R⁴=C₁-C₂₀-hydrocarbons and X=C₁-C₂₀-hydrocarbons, Si(CH₃)₂, and n,m=1,2

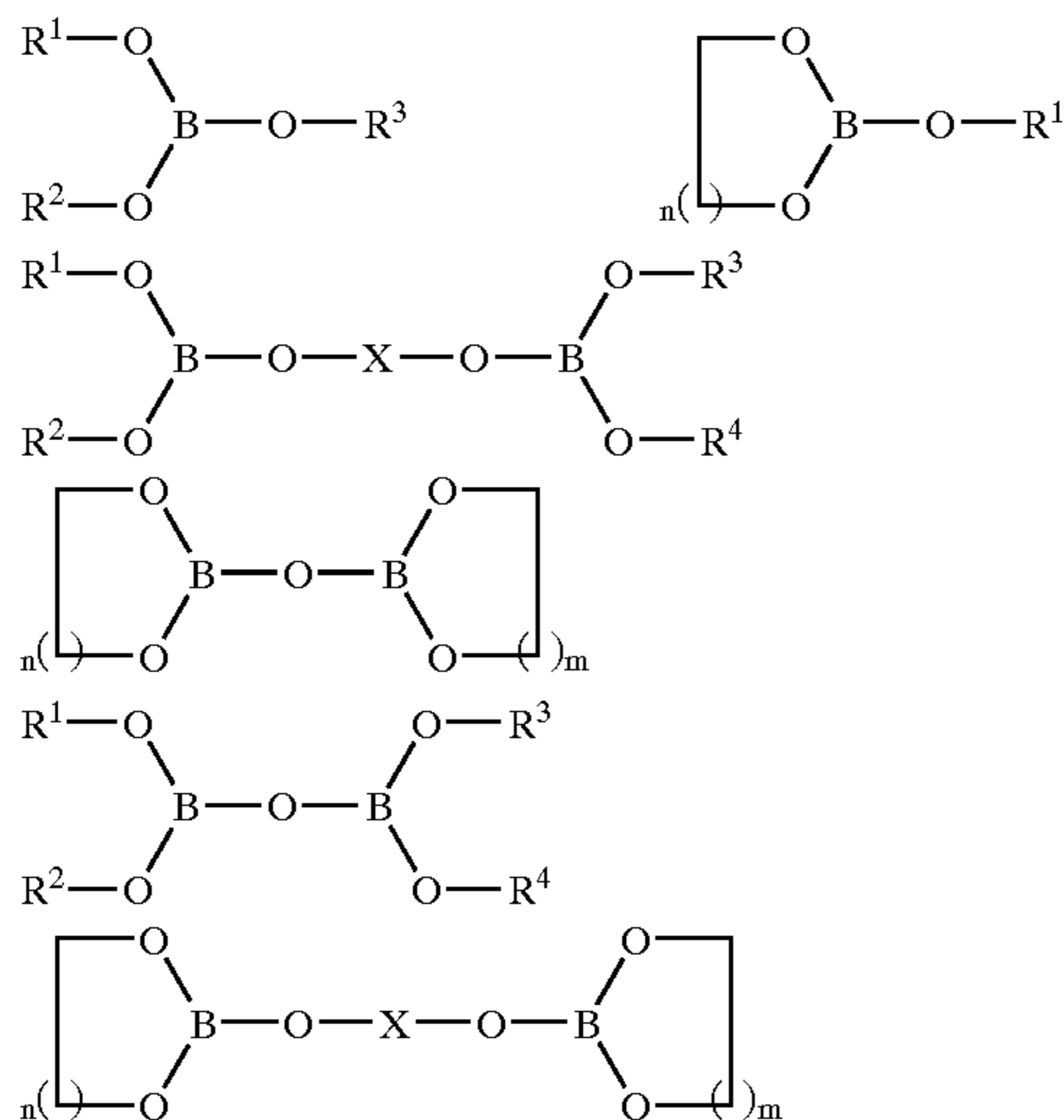

[0130] particularly trimethyl borate, triethyl borate, tripropyl borate, tributyl borate, trimethylen borate, 2-methyl-1,

3,2-dioxaborinane, 2-ethyl-1,3,2-dioxaborinane, 2-propyl-1,3,2-dioxaborinane, 2-butyl-1,3,2-dioxaborinane, 2-phenyl-1,3,2-dioxaborinane.

[0131] Furthermore, at least one ester of the formulae (E1) to (E5) as shown below, may be used as plasticizer (V):

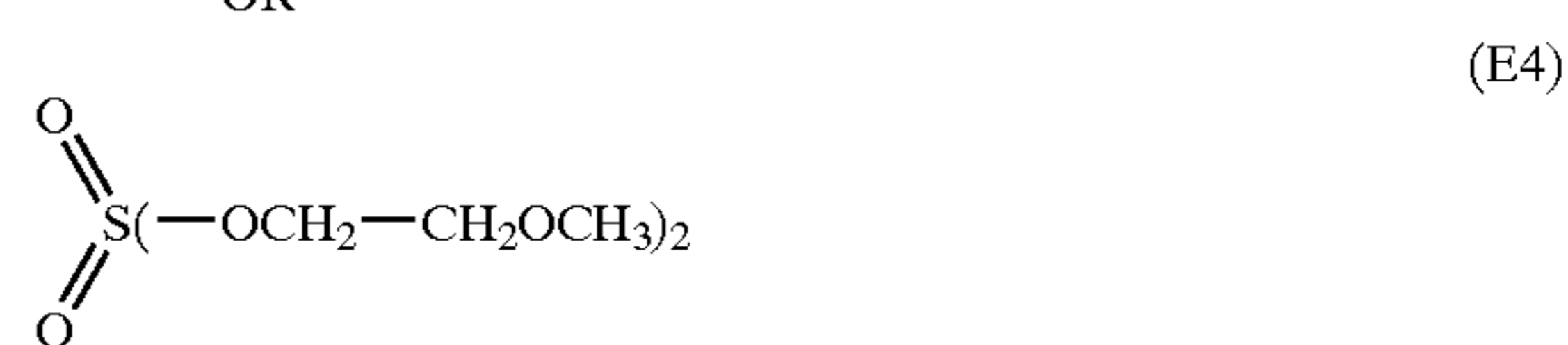

[0132] wherein R¹, R², R³, R⁴ may be the same or different and represent independently from each other a linear or branched C₁-C₄-alkyl group, (—CH₂—CH₂—O)_n—CH₃ wherein n=1 to 3, a C₃- to C₆-cycloalkyl group, an aromatic hydrocarbon residue, which may be substituted, under the proviso that at least one of the groups R¹, R², R³ or R⁴ is (—CH₂—CH₂—O)_n—CH₃ wherein n=1 to 3.

[0133] Within the above-mentioned esters of the formulae (E1) to (E5), the phosphoric acid esters of the formula (E3) are preferably used.

[0134] Examples for the group R¹, R² and—if present—R³ and/or R⁴ are methyl, ethyl, n- and iso-propyl, n- and tert.-butyl, cyclopentyl, cyclohexyl and benzyl, as well as (—CH₂—CH₂—O)_n—CH₃ wherein n=1 to 3, however, as already outlined above, under the proviso that at least one of the groups R¹, R², R³ and R⁴ is (—CH₂—CH₂—O)_n—CH₃ wherein n=1 to 3, preferably 1 or 2.

[0135] More preferably, esters of the general formulae (E1) to (E5), wherein R¹, R² and—if present—R³ and/or R⁴ are identical and represent —CH₂—CH₂—O—CH₃ or (—CH₂—CH₂—O)₂—CH₃, are used. Among those, the respective phosphoric acid esters are preferred. Examples for particular preferably used compounds are those of the formulae (E1a) to (E5a):

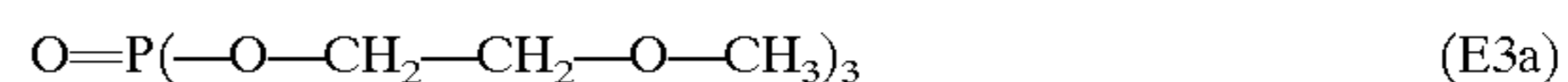

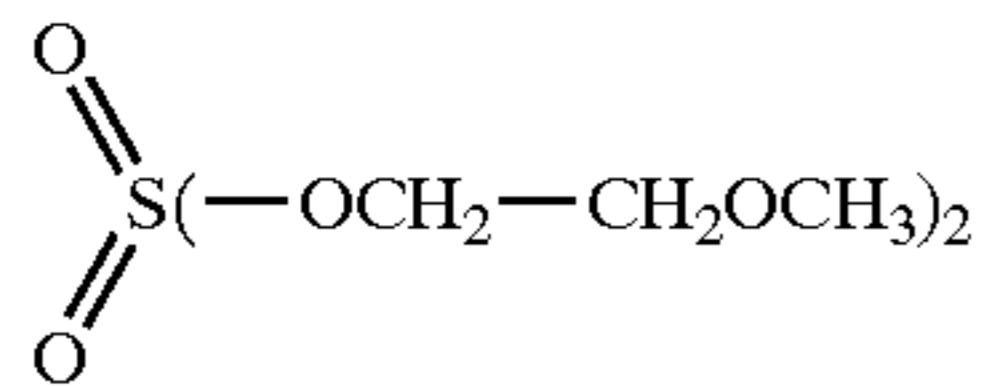

(E4a)

[0136] and



[0137] With respect to their properties, the esters used herein are extraordinarily suitable to be used as plasticizers in films and in general exhibit a viscosity at room temperature of ≤ 10 mPas preferably 5 mPas and particularly ≤ 3 mPas. They exhibit boiling points of in general about 200° C. or higher, preferably about 250° C. or higher and particularly about 300° C. or higher, as measured at atmospheric pressure, respectively. Furthermore, at the temperature of use of about -50° C. to about 150° C., they exhibit a low vapour pressure of about 10^{-5} to 10^0 . Due to their boiling points they may be distilled and thus may be obtained in high purity when prepared. Furthermore, at atmospheric pressure these esters are in the liquid state, over a broad temperature range. Generally, they are in the liquid state down to a temperature of about -300° C., preferably down to about -40° C. The esters as disclosed herein, may be used as solvents in electrolyte systems for Li-ion accumulators at at least about 80° C., preferably at at least about 120° C., more preferably at at least about 150° C.

[0138] The esters as used according to the invention may also be used in admixture with the above-mentioned plasticizers.

[0139] Solvent combinations which exhibit a sufficiently low viscosity, which are capable of strongly dissolving the ions of the conducting salt, which are in the liquid state over a broad temperature range and which are sufficiently electrochemically and chemically stable and which are hydrolysis resistant are preferred.

[0140] The esters used according to the present invention may be prepared according to common processes, as e.g. disclosed in K. Mura Kami, Chem. High Polymers (Japan), 7, p. 188-193 (1950) and in H. Steinberg Organoboron Chemistry, chapter 5, J. Wiley & Sons, N.Y. 1964. In general one starts with the acids, acid anhydrides or chlorides corresponding to the respective esters, such as boric acid, $\text{C}(\text{O})\text{Cl}_2$, POCl_3 , SO_2Cl_2 and SiCl_4 , and reacts those in a known manner with the respective single or polyvalent alcohols or etherols.

[0141] The amount of plasticizer, based on the total weight of the pigment m and the polymeric binder IV is from 1 to 200 wt %, preferably from 2 to 100 wt %, more preferably 2 to 70 wt %.

[0142] Suitable as conducting salts are the conducting salts which are generally known and are described, for example, in EP-A 96 629. Particularly suitable in this context are compounds such as e.g. LiPF_6 , LiAsF_6 , LiSbF_6 , LiClO_4 , $\text{Li}(\text{CF}_3\text{SO}_2)_3$, $\text{LiN}(\text{CF}_3\text{SO}_2)_2$, LiBF_4 or LiCF_3SO_3 , $\text{LiN}(\text{SO}_2\text{C}_n\text{F}_{2n+1})_2$, $\text{LiC}[(\text{C}_n\text{F}_{2n+1})\text{SO}_2]_3$, $\text{Li}(\text{C}_n\text{F}_{2n+1})\text{SO}_2$, wherein $n=2$ to 20, respectively, $\text{LiN}(\text{SO}_2\text{F})_2$, LiAlCl_4 , LiSiF_6 , $(\text{RSO}_2)_n\text{XLi}$ ($n=1, 2, 3, 4$, $\text{X}=\text{O}, \text{S}, \text{N}, \text{P}, \text{C}, \text{Si}$; $\text{R}=\text{C}_m\text{F}_{2m+1}$ wherein $m=0-10$ or C_1-C_{20} -hydro-

carbons) and mixtures of such compounds. LiBF_4 is preferably used as the conductive salt. Particularly preferred is the combination of the esters of the formulae (E1a) to (E5a) with LiBF_4 as the conductive salt. Among those, the combination of esters of formula (E3a) and LiBF_4 as the conductive salt are particularly preferred. These conducting salts are used in amounts of from 0.1 to 50 wt %, preferably from 1 to 10 wt %, in each case based on the mixture.

[0143] If required, dispersing resins can be used, to improve dispersion of the pigments, as described in the patent EP 940197.

[0144] Potentially suitable as a support material for the molded articles produced according to the invention are the materials usually employed for electrodes, preferably metals such as aluminum and copper. Equally, temporary intermediate supports such as sheets, in particular polyester sheets such as polyethylene terephthalate sheets can be used. Such sheets can advantageously be provided with a parting layer, preferably of polysiloxanes.

[0145] Furthermore, the mixtures used according to the invention may, after or during melt extrusion, preferably after the latter, be cross-linked in a manner known per se.

[0146] This is effected, for example, by irradiation with ionic or ionizing radiation, electron beam, preferably with an acceleration voltage of between 20 and 2000 kV and a radiation dose of between 5 and 50 Mrad, UV or visible light, with the advantageous option, in the usual way, of adding an initiator such as benzyl dimethyl ketal or 1,3,5-trimethylbenzoyl-triphenylphosphine oxide in amounts of, in particular, at most 1 wt %, based on the polymeric binder and carrying out the cross-linking over a period of, in general, from 0.5 to 15 minutes, advantageously under inert gas such as nitrogen or argon, by thermal free-radical polymerization, preferably at temperatures of above 60° C., with the advantageous option of an initiator such as azobis-isobutyronitrile being added in amounts of, in general, at most 5 wt %, preferably from 0.05 to 1 wt %, based on the polymeric binder, by electrochemically induced polymerization or by ionic polymerization, for example by acid-catalyzed cationic polymerization, potentially suitable catalysts in the first instance being acids, preferably Lewis acids such as BF_3 or, in particular, LiBF_4 or LiPF_6 . Lithium ion-containing catalysts such as LiBF_4 or LiPF_6 may, in this case, advantageously remain as a conducting salt within the solid electrolyte or separator.

[0147] The present invention further relates to a molded article, preferably a sheet-type molded article which can be obtained by a method, which method comprises the following stage:

[0148] I) Compounding and melt extrusion of a mixture I which comprises a blend II which contains:

[0149] a) from 1 to 95 wt % of at least one pigment III having a primary particle size of from 5 nm to 20 nm which is selected from the group consisting of an electrochemically inert solid IIIa, a compound IIIb which during charging is able to give off lithium ions, and a compound IIIc which during charging is able to take up lithium ions, and a mixture of the solid IIIa with the compound IIIb or the compound IIIc,

[0150] b) from 5 to 99 wt % of at least one polymeric binder IV, and

[0151] c) from 0 to 200 wt %, based on the total amount of the components a) and b), of at least one plasticizer V,

[0152] wherein the proportion by weight of the blend II in the mixture I is from 1 to 100 wt %, and

[0153] wherein mixtures I comprising blends II containing, as the polymeric binder IV, a copolymer of vinylidene fluoride (VdF) and hexafluoropropylene (HFP) having an HFP content of from 8 to 25 wt % and, as the plasticizer V, a compound selected from the group consisting of dibutyl phthalate, dimethyl phthalate, diethyl phthalate, tris(butoxyethyl)phosphate, propylene carbonate, ethylene carbonate, trimethyl trimellitate and mixtures thereof are excluded.

[0154] The present invention further relates to a composite body, preferably in the form of a sheet, more preferably in the form of a sheet having a total thickness of from 15 to 1500 mm, in particular having a total thickness of from 50 to 500 mm, which can be obtained by a method, which method comprises the following stages:

[0155] (I) the preparation of at least one first layer by compounding and melt extrusion of a mixture I as defined above, said mixture comprising a blend II which contains a solid IIIb or a solid IIIc as defined above, respectively;

[0156] (II) the preparation of at least one second layer by compounding and melt extrusion of a mixture I as defined above, said mixture comprising a blend II which contains a solid IIIa, as defined herein, and is free from a solid IIIb or a solid IIIc, and

[0157] (III) a subsequent bringing together of the at least one first layer and the at least one second layer by a conventional facing method.

[0158] The present invention further relates to a composite body which can be obtained by a method, which method comprises the following stages:

[0159] (I) the preparation of at least one first layer by compounding and melt extrusion of a mixture I as defined above, said mixture comprising a blend II which contains a solid IIIb or a solid IIIc as defined above, respectively;

[0160] (II) the preparation of at least one second layer by compounding and melt extrusion of a mixture I as defined above, said mixture comprising a blend II which contains a solid IIIa, as defined herein, and is free from a solid IIIb or a solid IIIc, and

[0161] (III) a subsequent bringing together of the at least one first layer and the at least one second layer by a conventional facing method.

[0162] The at least one second layer is preferably prepared on a temporary support. In the process it is possible to employ, according to the invention, customarily used temporary supports such as e.g. a parting sheet made of a polymer or a preferably coated paper such as e.g. a siliconized polyester sheet. This second layer can, however, alternately be prepared on a permanent support such as e.g. a collector electrode or even entirely without a support. In so doing, said layer can be either extruded together with the support or extruded directly onto it.

[0163] For preparing the composite film, smoothing tools, such as chill-roll devices and devices for preparing tubular films are preferably used.

[0164] The process of bringing together or producing the above-defined layers is effected by processes under atmospheric pressure for the coating or fabrication of sheets, such as e.g. casting or blade coating, and by processing methods under pressure such as e.g. extrusion, coextrusion, laminating, facing, calendering or pressing. If required, the composite sheet thus produced may be cross-linked or cured by radiation, electrochemically or thermally.

[0165] As is implied by the above it is thus readily possible to provide a composite body comprising the components parting sheet/separator (second layer)/electrode (first layer).

[0166] It is further possible, by facing on both sides, to provide a composite body comprising the components anode/separator/cathode.

[0167] The process of charging such composite bodies with an electrolyte and conducting salt can be carried out both before the layers are brought together and, preferably, after this operation, if required after contact has been made with suitable collector electrodes, e.g. a metal foil, and even after the layers have been introduced into a battery jacket, the special microporous structure of the layers, if the mixture according to the invention is used, in particular owing to the presence of the above-defined solid in the separator and possibly in the electrodes, enabling the electrolyte and the conducting salt to be absorbed and the air in the pores to be displaced. The charging operation can be carried out at temperatures of from 0° C. to approximately 100° C., depending on the electrolyte employed.

[0168] The molded articles are produced by compounding and melt extrusion, preferably at from about 50 to about 250° C.

[0169] The equipment used for extrusion in this context preferably is in the form of a plasticating single-screw extruder such as e.g. a Berstorff single-shaft mixing extruder, a Frenkel mixer, a plasticator or a Buss co-kneader, a twin-screw extruder of a corotating or counterrotating type, such as e.g. an extruder with COLOMBO screws, an extruder with closely meshing ZSK screws, an extruder with Holo-Flite twin screws, a Leistritz kneading pump, an extruder with a Pasquetti twin screw, an extruder with cotruder screws, an extruder of the Kestermann type, an extruder with Mapré twin screws, a GETECHA compounding extruder, an Anger tandem extruder, a Zimmermann-Jansen extruder, a twin-shaft continuous kneader such as e.g. a DSM twin-shaft mixer, an Eck mixtruder, an FCM kneader or a List all-phase appliance or a continuous multishaft extruder such as e.g. a four-screw extruder or a planetary gear extruder or a combination of two or more of these.

[0170] Suitable as particularly preferred appliances are single- and twin-screw machines such as e.g. single-shaft mixing extruders (Reifenhäuser, Krauss Maffei, Berstorff), corotating or counterrotating closely meshing twin-screw kneaders (Werner und Pfeiderer, Berstorff, APV), multi-screw extruders, Buss co-kneaders or counterrotating, non-meshing kneaders (Farrel, JSW).

[0171] Screws and cylinders of the continuous-operation extrusion plant ZSK 30 are of modular design. To achieve

adequate plastication, dispersion and homogenization of the individual components, the process section consists of at most 15 cylinder zones, corresponding to 45 units in length per diameter. Each zone is separately equipped with an electric heater. The casings are cooled with compressed air or water.

[0172] The screw consists of a plurality of conveying, plasticating and mixing zones. A special configuration of different kneading and mixing elements is required for gentle, homogeneous dispersion of the solids, explicitly of the inorganic pigments, in the polymeric binder.

[0173] If the molded article according to the invention is to be employed as a solid electrolyte in an electrochemical cell it is advisable to incorporate a dissociable, lithium cation-containing compound, a conducting salt as defined above and further additives such as, in particular, organic solvents, referred to as electrolyte.

[0174] These substances can be admixed to the suspension, in part or in their entirety, when the layer is being produced, or can be introduced into the layer after it has been produced.

[0175] Potentially suitable organic electrolytes include the esters of formulae (E1) to (E5) and the compounds discussed above in the category "plasticizer V", preference being given to the use of those esters, particularly those of the formula (E3), and the customary organic electrolytes, preferably esters such as ethylene carbonate, propylene carbonate, dimethyl carbonate and diethyl carbonate or mixtures of such compounds.

[0176] Solid electrolytes, separators and/or electrodes according to the invention, which are suitable for electrochemical cells, should advantageously have a thickness of from 5 to 500 μm , preferably from 10 to 500 μm , more preferably from 10 to 200 μm and in particular from 20 to 100 μm .

[0177] As implied by the above, the present invention also relates to the use of a molded article according to the invention or a composite body according to the invention or of a molded article or composite body produced by means of a method according to the invention for producing a solid electrolyte, a separator, an electrode, in a sensor, an electrochromic window, a display, a capacitor or an ion-conducting foil.

[0178] The invention further relates to a separator, a solid electrolyte, an electrode, a sensor, an electrochromic window, a display, a capacitor or an ion-conducting foil comprising a molded article or composite body according to the invention or a molded article or composite body produced according to the invention, and to an electrochemical cell comprising a separator, solid electrolyte or an electrode as defined above or to a combination of two or more of these.

[0179] This electrochemical cell can be used, in particular, as a motor vehicle battery, appliance battery or flat-type battery.

[0180] Furthermore, the present invention also provides a motor vehicle battery, appliance battery or flat-type battery comprising an electrochemical cell as described above.

EXAMPLES

[0181] To illustrate what happens, in principle, within the method according to the invention, the present application is accompanied by three figures.

[0182] FIG. 1 shows a schematic depiction of the production of a cathode foil by means of an extruder and an extruder with an ancillary extruder;

[0183] FIG. 2 shows a schematic depiction of a coextrusion of a mixture used according to the invention, together with a PET sheet;

[0184] FIG. 3 shows a schematic depiction of the production of a cathode (LiMn_2O_4) and an anode foil (MCMB).

[0185] First of all, the principles of the production process according to the invention, as they are shown schematically in FIG. 1, will be described by way of example relating to a corotating, closely meshing twin-screw kneader ZSK 30 from Wemer und Pfleiderer.

[0186] The corotating and closely meshing and thus self-cleaning extruder (E) consists of a plurality (up to 15) of variable fittable individual zones which can be temperature-controlled via heating circuits.

[0187] Addition of the components:

[0188] a) The polymers (P) were homogeneously dispersed, in a fluid mixer, with the pigment and part of the plasticizer. The addition was carried out via a proportioning balance. Where necessary, the extruder was inerted with nitrogen.

[0189] b) If required, the plasticizer was added via a proportioning pump in the homogenizing section of the extruder.

[0190] c) The conductive black (LR) was added via an ancillary extruder (SE) in the homogenizing phase. The ancillary extruder was a single- or twin-shaft extruder. If required, a homogeneous melt of polymer, plasticizer and conductive black and, where appropriate, dispersing resin was prepared in the ancillary extruder and introduced laterally into the main extruder. The sheet was discharged via a flat-sheet die and calendered. If required, the sheet was coextruded between two sheets (e.g. polyethylene terephthalate (PET)) (FIG. 2). The thickness of the battery foils was between 10 and 1000 μm .

[0191] Among the advantages of the production process according to the invention the following can be mentioned:

[0192] 1. Solvent can be dispensed with

[0193] 2. Drying of the battery foils can be dispensed with

[0194] 3. Extraction and extraction solvent can be dispensed with

[0195] 4. The sheet can be incorporated into the battery without further pretreatment

[0196] 5. More homogeneous dispersion of the pigments

[0197] 6. Better mechanical stability of the films (than sheeting produced via casting technology).

EXAMPLE 1

Preparation of a Cathode Foil

[0198]

4.910 g	of LiMn ₂ O ₄
1.310 g	of poly(vinylidene fluoride)/hexafluoropropene copolymer Kynar® 2801 (Elf Atochem)
1.030 g	of conductive carbon black Super® P (MMM Carbon)
2.740 g	of tributyl phosphate (TBP)

[0199] Extruder Configuration:

[0200] Corotating twin-shaft main extruder ZSK30 with 10 variable heatable heating zones. In the fourth zone a corotating twin-shaft ancillary extruder ZSK30 with 6 variable heatable heating zones was attached.

[0201] Preparation:

[0202] 180 g/h of a blend of 100 parts of Kynar® 2801 and 5 parts of propylene carbonate and 442 g/h of conductive black Super® P were metered into the first zone of the ancillary extruder ZSK30. In addition, 1075 g/h of propylene carbonate were pumped into the homogenizing section (zone 2) of the ancillary extruder. This melt was introduced into the homogenizing section (zone 4) of the main extruder. In addition, 2600 g of a mixture of 15.1 parts of Kynar® 2801, 81.1 parts of LiMn₂O₄ and 3.8 parts of propylene carbonate were metered into the first zone of the main extruder. The internal temperature in the two extruders was 150° C. Via a heatable flat film die (150° C.) having a gap width of 5 mm the melt was discharged and coextruded between two PET sheets and then calendered.

[0203] The sheet obtained had the following characteristics:

Surface resistance:	140 Ohms
Sheet thickness:	100–500 mm

EXAMPLE 2

Preparation of an Anode Foil

[0204]

Composition:

5600 g	of MCMB (Osaka Gas)
1500 g	of poly(vinylidene fluoride)/hexafluoropropene copolymer Kynar® 2801 (Elf Atochem)
400 g	of conductive black Super® P (MMM Carbon)
2500 g	of tributyl phosphate (TBP)

[0205] Extruder Configuration: See Example 1

[0206] Preparation:

[0207] 180 g/h of a mixture of 100 parts of Kynar® 2801 and 5 parts of propylene carbonate and 150 g/h of conductive black Super® P (SP) were metered into the first zone of

the ancillary extruder ZSK30. In addition, 841 g/h of propylene carbonate were pumped into the homogenizing section (zone 2) of the ancillary extruder. This melt was introduced into the homogenizing section (zone 4) of the main extruder.

[0208] In addition, 2600 g/h of a blend of 15.1 parts of Kynar® 2801, 80.8 parts of MCMB and 3.4 parts of propylene carbonate were metered into the first zone of the main extruder. The internal temperature in the two extruders was 150° C.

[0209] Via a heatable flat film die (150° C.) having a gap width of 5 mm the melt was discharged and coextruded between two PET sheets and then calendered.

[0210] The sheet obtained had the following characteristics:

Surface resistance:	80 Ohms
Sheet thickness:	50–300 mm

[0211] The preparation of the abovementioned cathode and anode foils is shown schematically in FIG. 3.

EXAMPLE 3

Preparation of a Separator Foil

[0212]

3000 g	of poly(vinylidene fluoride)/ hexafluoropropene copolymer Kynar® 2801 (Elf Atochem)
2000 g	of Aerosil® (AE) R 812 (Degussa)
5000 g	of tributyl phosphate

[0213] Preparation:

[0214] 4500 g/h of a mixture of 30 parts of Kynar® 2801, 20 parts of Aerosil® R 812 and 50 parts of tributyl phosphate are metered into a corotating twin-shaft extruder ZSK40 with 10 variable heatable heating zones. The internal temperature in the extruder is 150° C. The melt is discharged via a heatable flat film die having a gap width of 1 mm and is coextruded between two PET sheets and then calendered.

[0215] Sheet thickness: from 20 to 100 mm

EXAMPLE 4

[0216]

3000 g	of polymethacrylate (Luryl® PMMA G88, BASF)
2000 g	of Aerosil® R 812 (Degussa)
5000 g	of tributyl phosphate

[0217] Preparation as in Example 3

EXAMPLE 5

[0218]

3000 g	of polyacrylonitrile (Dralon ® T, Bayer)
2000 g	of Aerosil ® R 812 (Degussa)
5000 g	of tributyl phosphate

[0219] Preparation as in Example 3

EXAMPLE 6

[0220]

3000 g	of polyethylene (Lupolen ®, BASF)
2000 g	of Aerosil ® R 812 (Degussa)
5000 g	of tributyl phosphate

[0221] Preparation as in Example 3

EXAMPLE 7

[0222]

3000 g	of polypropylene (Novolen ®, BASF)
2000 g	of Aerosil ® R 812 (Degussa)
5000 g	of tributyl phosphate

[0223] Preparation as in Example 3

EXAMPLE 8

[0224]

3000 g	of poly(vinylidene fluoride)/hexafluoropropene copolymer Kynar ® 2801 (Elf Atochem)
2000 g	of Aerosil ® R 812 (Degussa)
5000 g	of dibutyl carbonate

[0225] Preparation as in Example 3

EXAMPLE 9

[0226]

3000 g	of poly(vinylidene fluoride)/hexafluoropropene copolymer Kynar ® 2801 (Elf Atochem)
1500 g	of Aerosil ® R 812 (Degussa)
1000 g	of wollastonite (Tremin ® 8000 EST, Quarzwerke, Frechen)
5000 g	of tributyl phosphate

[0227] Preparation as in Example 3

EXAMPLE 10

[0228]

2000 g	of poly(vinylidene fluoride)/hexafluoropropene copolymer Kynar ® 2801 (Elf Atochem)
1000 g	of poly(ethylene oxide) (Polyox ®, Union Carbide)
2000 g	of Aerosil ® R 812 (Degussa)
5000 g	of dibutyl carbonate

[0229] Preparation as in Example 3.

EXAMPLE 11

[0230] Using the cathode foil according to Example 1, the anode foil according to Example 2 and the separator foil according to Example 3, a composite body having the following structure was fabricated by laminating at a temperature of 140° C.:

[0231] Cathode foil/metal lattice foil (aluminum)/cathode foil

[0232] Separator foil

[0233] Anode foil/metal lattice foil (copper)/cathode foil.

[0234] The composite body was immersed for half an hour in a 1 molar solution of LiPF₆ in dimethyl carbonate/ethylene carbonate and then introduced into a flat-type battery jacket. The composite body had good resistance to swelling.

1-13 (canceled)

14. Method of using a molded article, produced by a method comprising the following stage:

I) compounding and melt extrusion of a mixture I which comprises a blend II which contains:

- a) from 1 to 95 wt.-% of at least one pigment III having a primary particle size of from 5 nm to 20µm which is selected from the group consisting of an electrochemically inert solid IIIa,
- b) from 5 to 99wt.-% of at least one polymeric binder IV, and
- c) from 1 to 200 wt.-%, based on the total amount of the components a) and b), at least one plasticizer V,

wherein the proportion by weight of the blend II in the mixture I is from 1 to 100 wt.-%, wherein mixtures I comprising blends II containing, as the polymeric binder IV, a copolymer of vinylidene fluoride (VdF) and hexafluoropropylene (HFP) having an HFP content of from 8 to 25 wt.-% and, as the plasticizer V, a compound selected from the group consisting of dibutyl phthalate, dimethyl phthalate, diethyl phthalate, tris(butoxyethyl) phosphate, propylene carbonate, ethylene carbonate, trimethyl trimellitate and mixtures thereof are excluded for the manufacture of an electrochromic window.

15. A method as claimed in claim 14, wherein the pigment III is a solid IIIa which is selected from the group consisting of an inorganic solid, selected from the group consisting of oxides, mixed oxides, silicates, sulfates, carbonates, phosphates, nitrides, amides, imides and carbides of the element

of the Ist, IInd, IIIrd or IVth main group of the IVth subgroup of the Periodic Table of the Elements.

16. A method as claimed in claim 14, wherein the pigment III is an oxide or a mixed oxide.

17. A method as claimed in claim 15, wherein the pigment III is an oxide or a mixed oxide.

18. A method as claimed in claim 16, wherein the oxide or mixed oxide is selected from silicon dioxide, aluminum oxide, magnesium oxide or titanium dioxide, or mixed oxides of the element silicon, calcium, aluminum, magnesium or titanium.

19. A method as claimed in claim 17, wherein the oxide or mixed oxide is selected from the group silicon dioxide, aluminum oxide, magnesium oxide or titanium dioxide, or mixed oxides of the element silicon, calcium, aluminum, magnesium or titanium.

20. A method as claimed in claim 14, wherein the pigment III is a solid IIIa which is selected from the group consisting of a polymer selected from the group consisting of polyethylene, polypropylene, polystyrene, poly(tetrafluoroethylene), poly(vinylidene fluoride), polyamides, polyimides, and a solid dispersion containing a polymer of this type and the mixture of two or more thereof.

21. A method as claimed in claim 14, wherein the pigment III has a primary particle size from 5 nm to 5 microns.

22. A method as claimed in claim 15, wherein the pigment III has a primary particle size from 5 nm to 5 microns.

23. A method as claimed in claim 20, wherein the pigment III has a primary particle size from 5 nm to 5 microns.

24. A method as claimed in claim 14, wherein the polymeric binder IV is selected from the group of homopolymers, block polymers or copolymers IVa (polymers IVa) which can be obtained by the polymerization of

b1) from 5 to 100 wt.-% based on the polymer IVa, of a condensation product VI of

α) at least one compound VII which is able to react with a carboxylic acid or a sulfonic acid or a derivative or a mixture of two or more of these, and

β) at least one mole per mole of the compound VII of a carboxylic acid or sulfonic acid VIII which has at least one free radical polymerizable functional group or of a derivative thereof or of a mixture of two or more of these and

b2) from 0 to 95 wt.-% based on the polymer IVa of a further compound IX having a mean molecular weight (number average) of at least 5,000 comprising polyether segments in the main chain or a side chain.

25. A method as claimed in claim 24, wherein the compound VII is a mono- or polyhydric alcohol, whose main chain contains exclusively carbon atoms.

26. A method as claimed in claim 24, wherein the carboxylic acid or sulfonic acid VIII or the derivative thereof is an α, β-unsaturated carboxylic acid or a derivative thereof.

27. A method as claimed in claim 24, wherein the content of the compound IX in the polymer IVa is 0% by weight based on the polymer IVa.

28. A method as claimed in claim 14, wherein the polymeric binder IV is selected from the group of homopoly-

mers, block polymers or copolymers IVb (polymers IVb), obtainable by polymerization of

b1) from 5 to 75 wt.-% based on the polymer IVb of an unsaturated compound X which is capable of free radical polymerization and differs from the above carboxylic acid or the sulfonic acid VIII or a derivative thereof, or a mixture of two or more of these and

b2) from 25 to 95 wt.-% based on the polymer IVb of a further compound IX, having a mean molecular weight (number average) of at least 5,000 and comprising polyether segments in the main chain or side chain as a polymeric binder.

29. A method as claimed in claim 28, wherein the compound X is selected from the group consisting of olefinic hydrocarbons, halogen contain olefinic compound, vinyl alcohols, vinyl acetate, aromatic olefinic compounds, vinyl ethers, or mixtures thereof.

30. A method as claimed in claim 14, wherein the polymeric binder IV is selected from homopolymers, block polymers and copolymers prepared from olefinic hydrocarbons, aromatic hydrocarbons, acrylic acid or methacrylic acid esters, acrylonitrile, methacrylonitrile, N-methyl-pyrrolidone, N-vinyl imidazole, vinyl acetate, vinyl ethers, halogen-containing olefinic compounds, 2-vinylpyridine, 4-vinylpyridine or vinylene carbonate.

31. A method as claimed in claim 14, wherein the polymeric binder IV is selected from polycarbonates, polyurethanes, polyesterols, polyamines, polysiloxanes, polyphosphazenes, or polyetherols.

32. An electrochromic window comprising a molded article produced by a method comprising the following stage:

I) compounding and melt extrusion of a mixture I which comprises a blend II which contains:

a) from 1 to 95 wt.-% of at least one pigment III having a primary particle size of from 5 nm to 20 μm which is selected from the group consisting of an electrochemically inert solid IIIa,

b) from 5 to 99 wt.-% of at least one polymeric binder IV, and

c) from 1 to 200 wt.-%, based on the total amount of the components a) and b), at last one plasticizer Vi,

wherein the proportion by weight of the blend II in the mixture I is from 1 to 100 wt.-%, and

wherein mixtures I comprising blends II containing, as the polymeric binder IV, a copolymer of vinylidene fluoride (VdF) and hexafluoropropylene (HFP) having a HFP content of from 8 to 25 wt.-% and, as the plasticizer V, a compound selected from the group consisting of dibutyl phthalate, dimethylphthalate, diethyl phthalate, tris(butoxyethyl) phosphate, propylene carbonate, ethylene carbonate, trimethyl trimellitate and mixtures thereof are excluded.

33. A method as claimed in claim 14, wherein the molded article is a sheet-type molded article.