



US 20040188696A1

(19) **United States**

(12) **Patent Application Publication**

Hsing Chen et al.

(10) **Pub. No.: US 2004/0188696 A1**

(43) **Pub. Date: Sep. 30, 2004**

(54) **LED POWER PACKAGE**

Publication Classification

(75) **Inventors:** **Chen-Lun Hsing Chen**, North Olmsted, OH (US); **Stanton Weaver JR.**, Northville, NY (US); **Ivan Eliashevich**, Maplewood, NJ (US); **Sebastien Libon**, New York, NY (US); **Mehmet Arik**, Niskayuna, NY (US); **David Shaddock**, Troy, NY (US)

(51) **Int. Cl.⁷** **H01L 33/00**

(52) **U.S. Cl.** **257/99**

(57) **ABSTRACT**

Surface mount light emitting diode (LED) packages each contain a light emitting diode (LED) die (24). A plurality of arrays of openings are drilled into an electrically insulating sub-mount wafer (10). A metal is applied to the drilled openings to produce a plurality of via arrays (12). The LED dice (24) are flip-chip bonded onto a frontside (16) of the sub-mount wafer (10). The p-type and n-type contacts of each flip-chip bonded LED (24) electrically communicate with a solderable backside (18) of the sub-mount wafer (10) through a via array (12). A thermal conduction path (10, 12) is provided for thermally conducting heat from the flip-chip bonded LED dice (24) to the solderable backside (18) of the sub-mount wafer (10). Subsequent to the flip-chip bonding, the sub-mount wafer (10) is separated to produce the surface mount LED packages.

Correspondence Address:
Scott A. McCollister, Esq.
Fay, Sharpe, Fagan, Minnich McKee, LLP
Seventh Floor
1100 Superior Avenue
Cleveland, OH 44114-2579 (US)

(73) **Assignee: GELcore, LLC**

(21) **Appl. No.: 10/402,505**

(22) **Filed: Mar. 28, 2003**

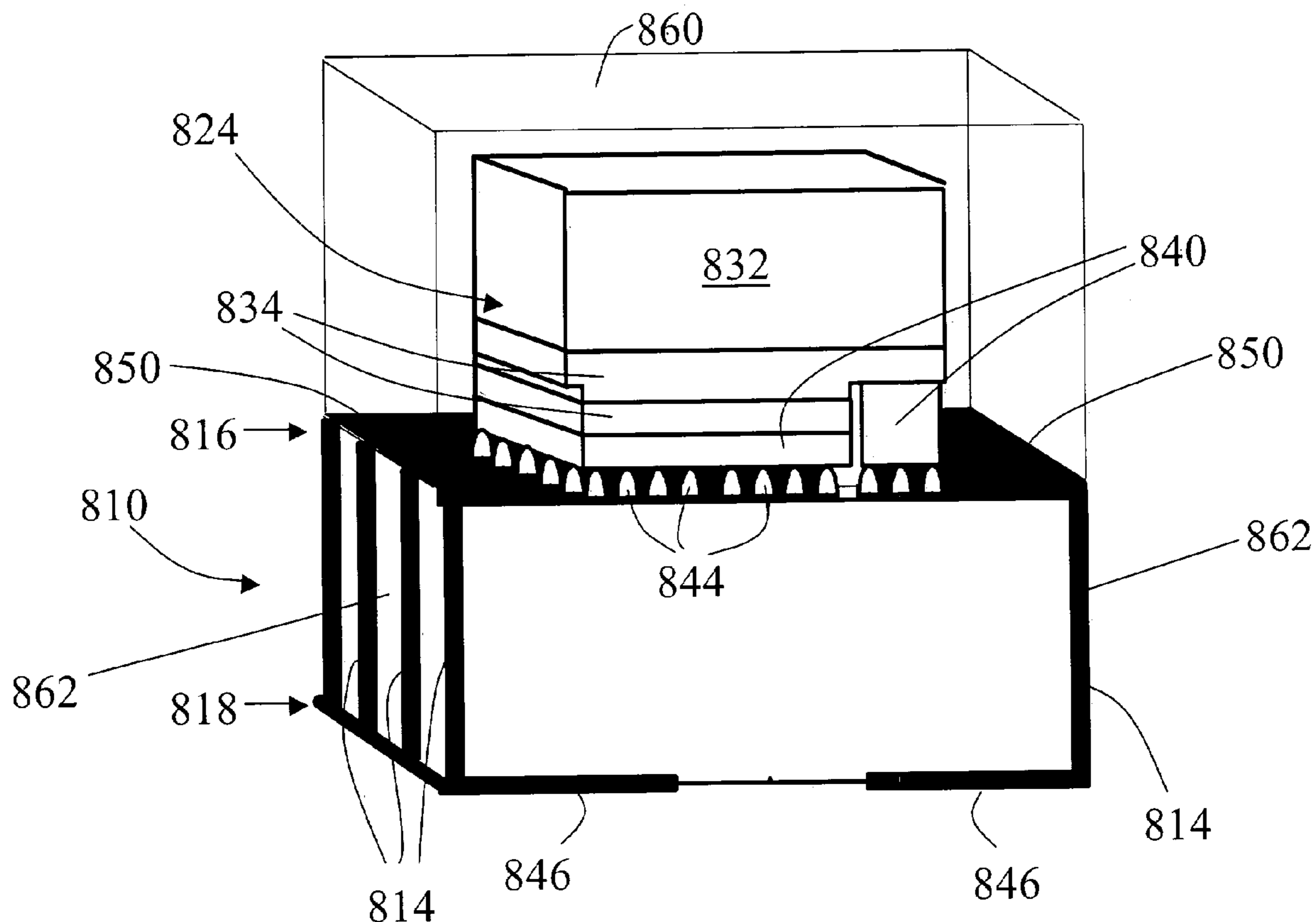

FIG 1B

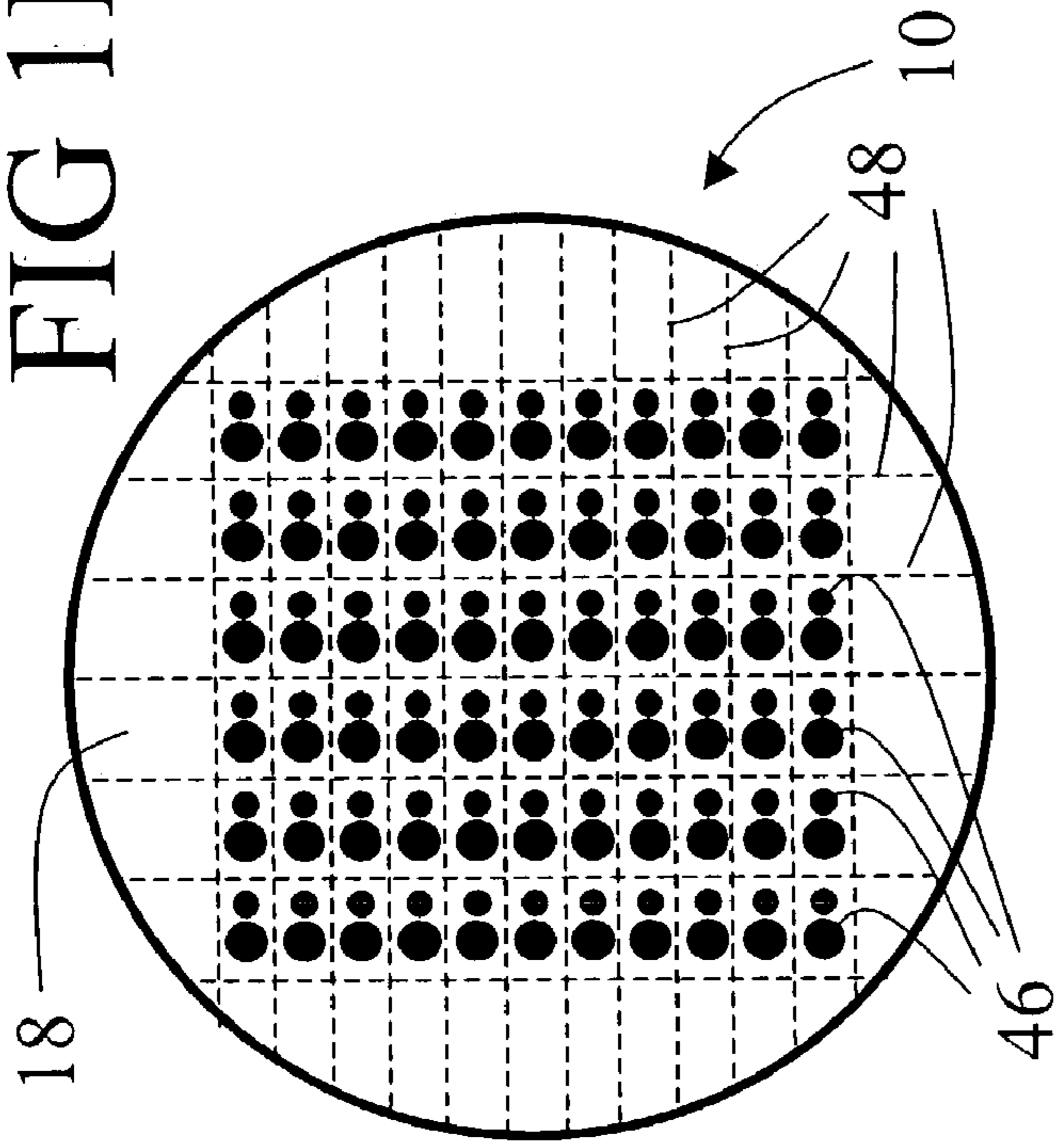

FIG 1A

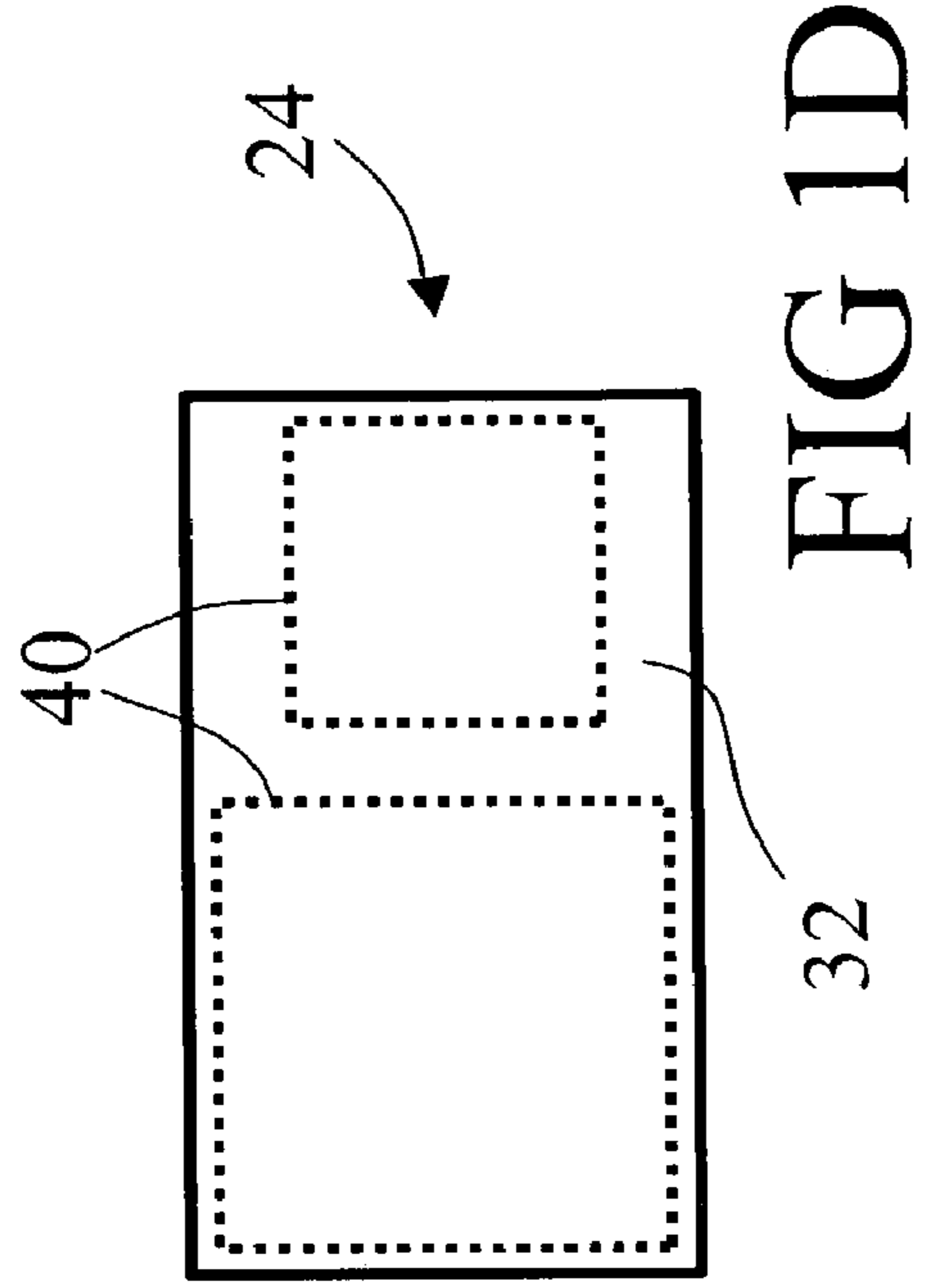
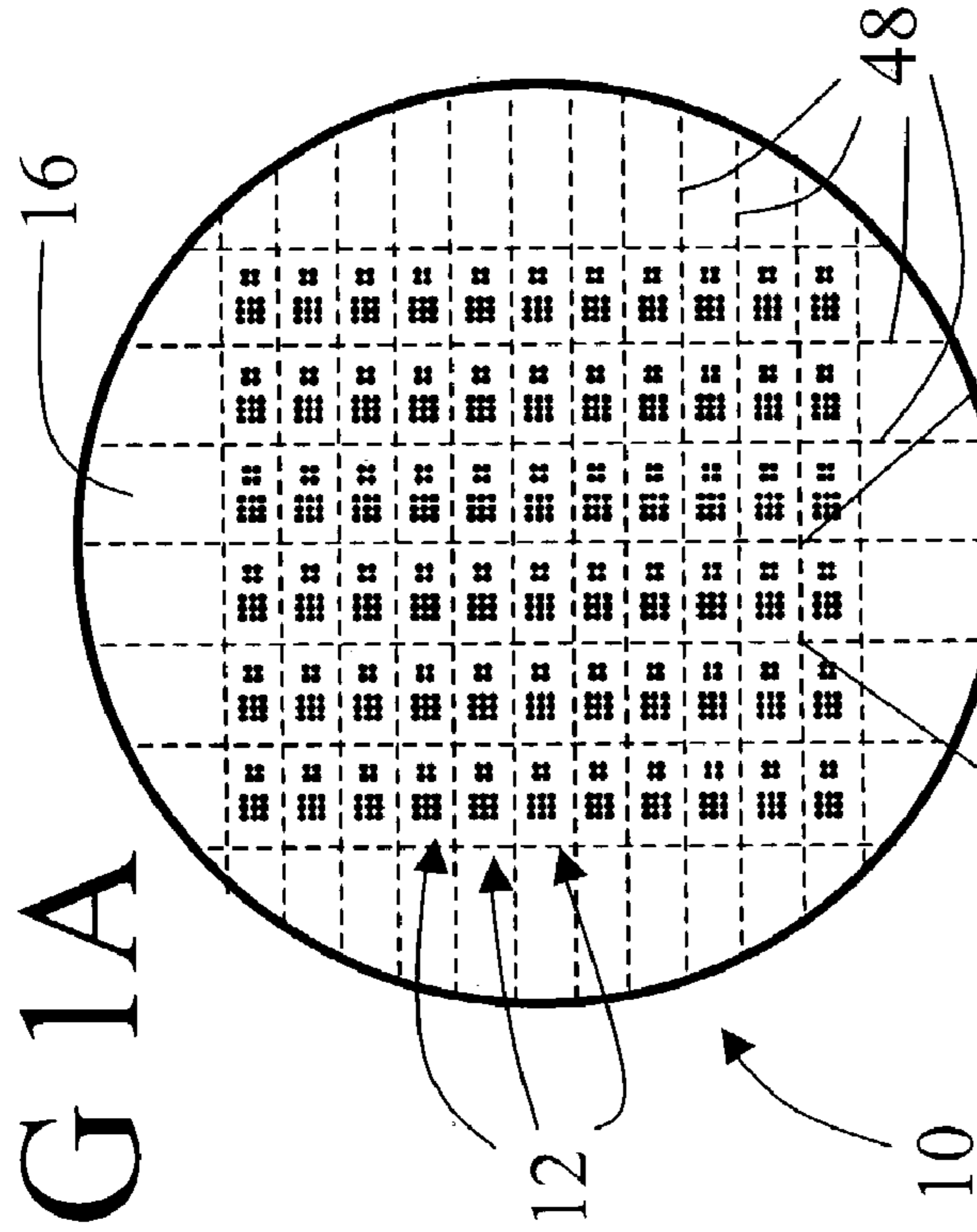

FIG 1D

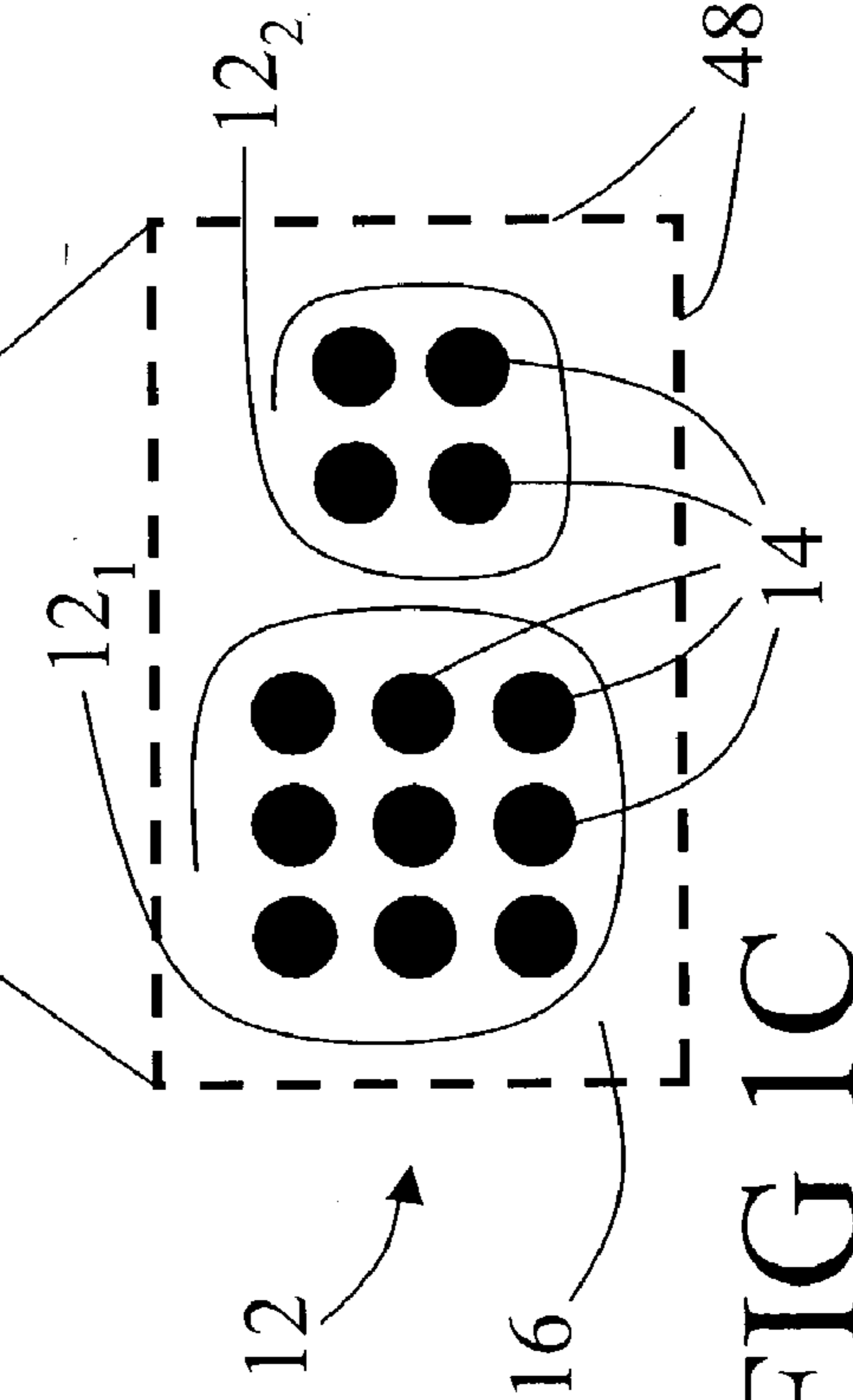

FIG 1C

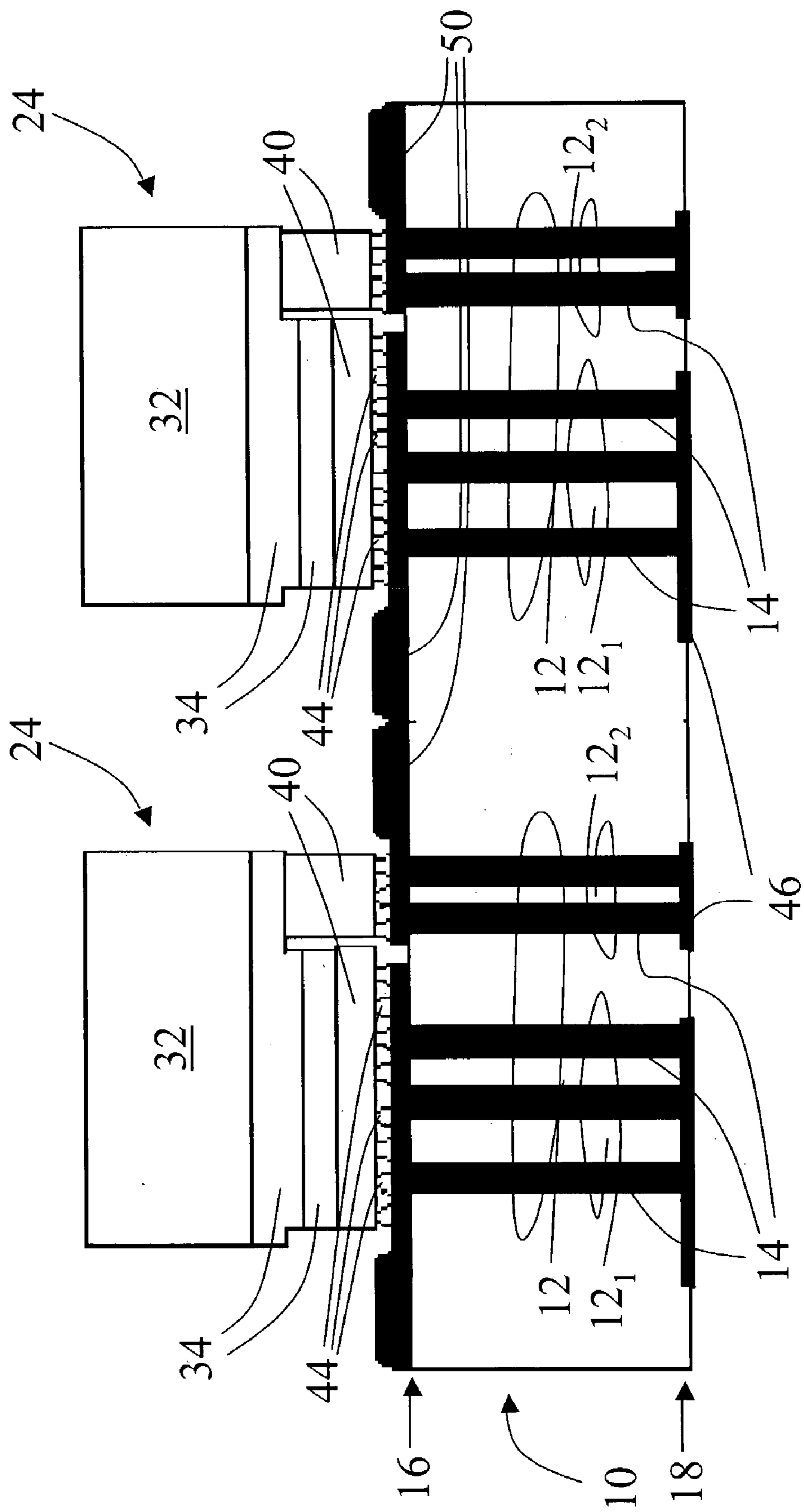

FIG 1E

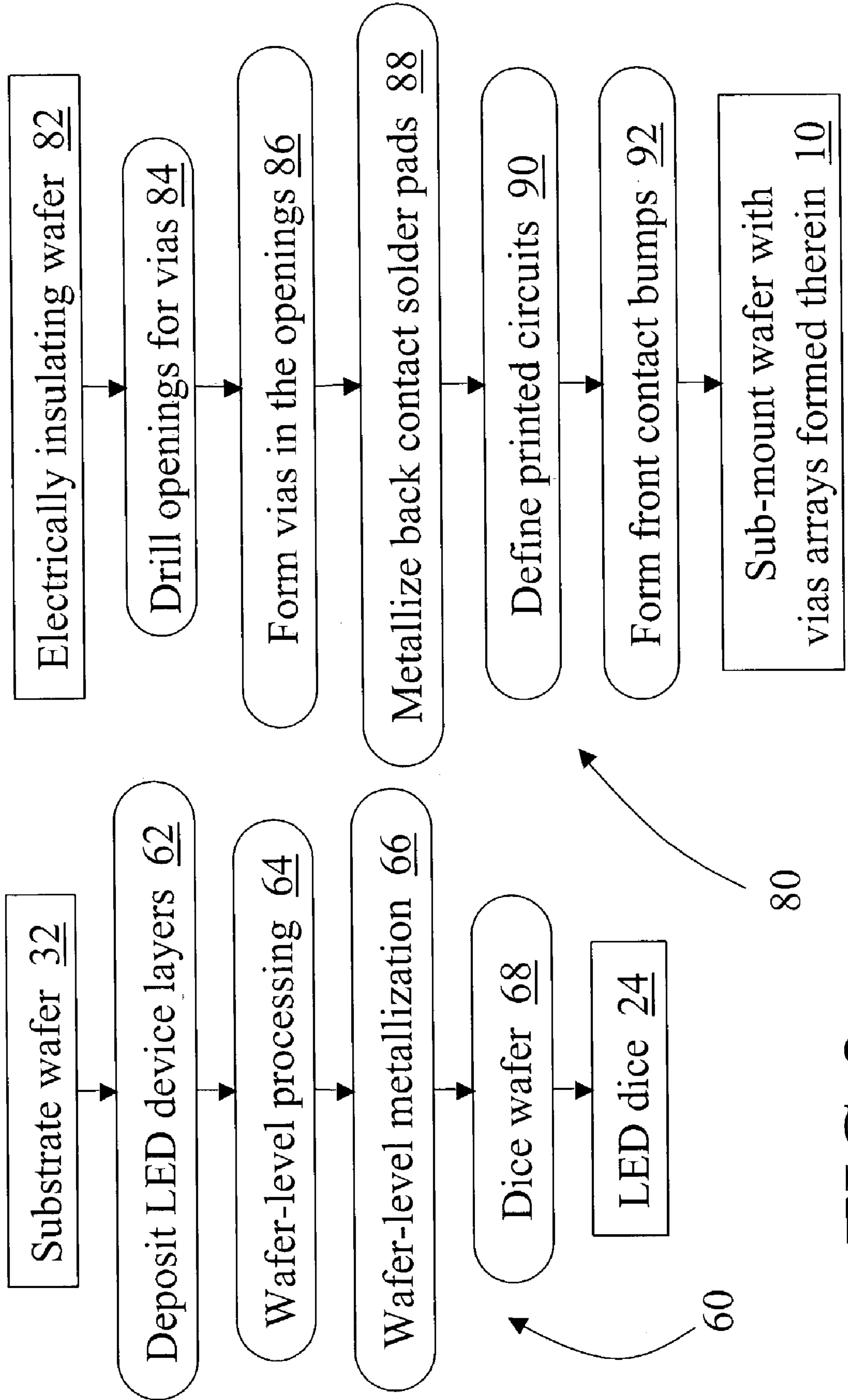

FIG 2

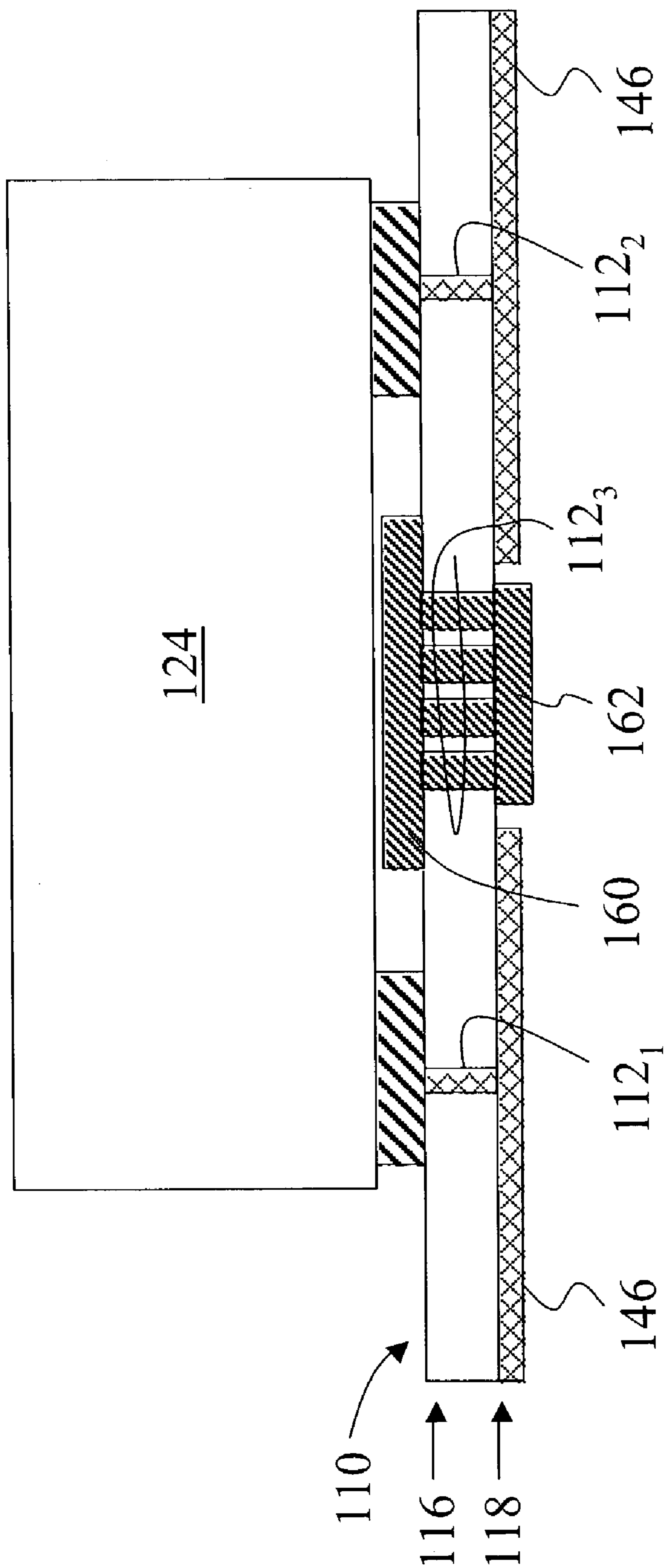

FIG 3

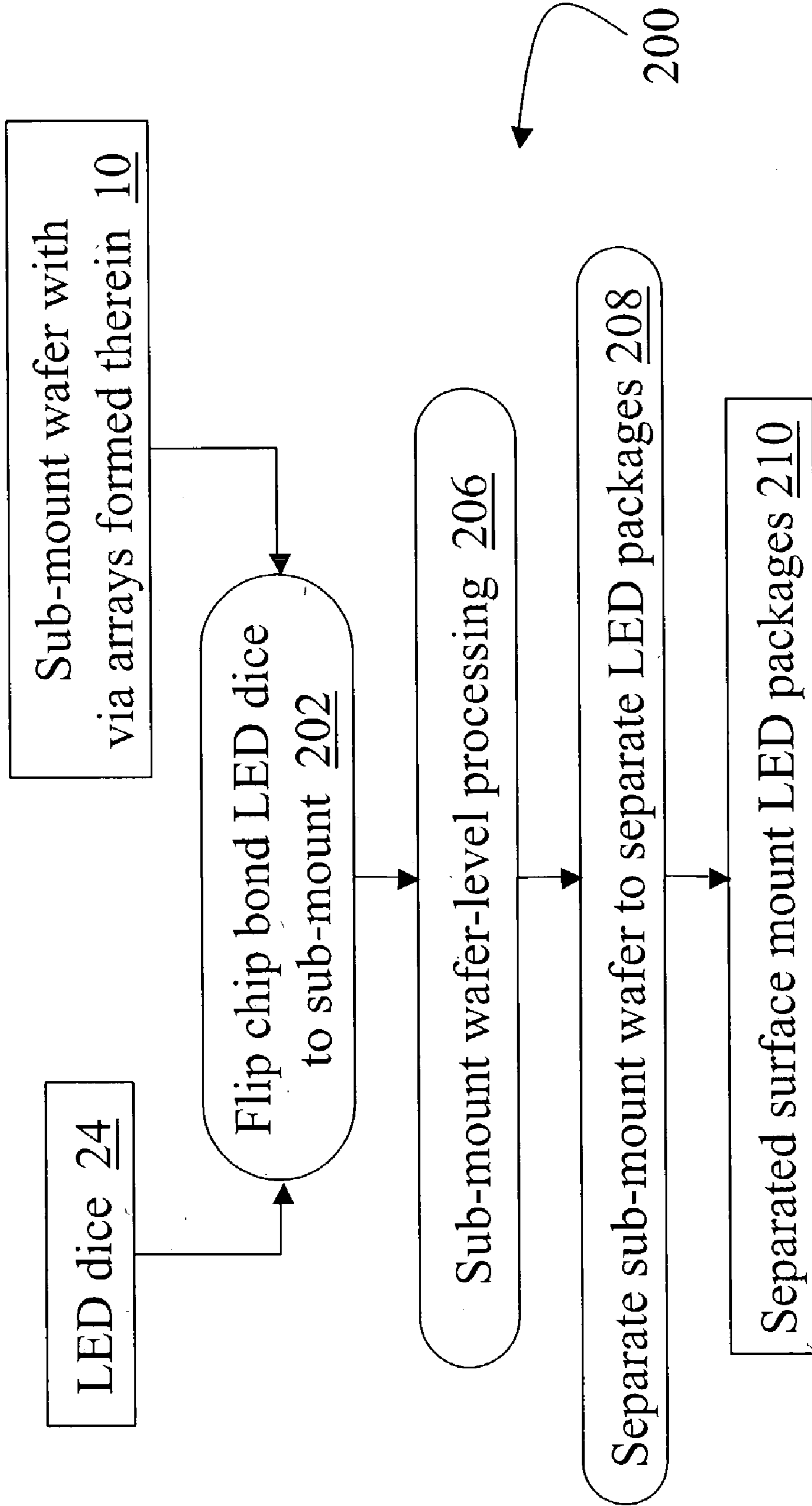

FIG 4

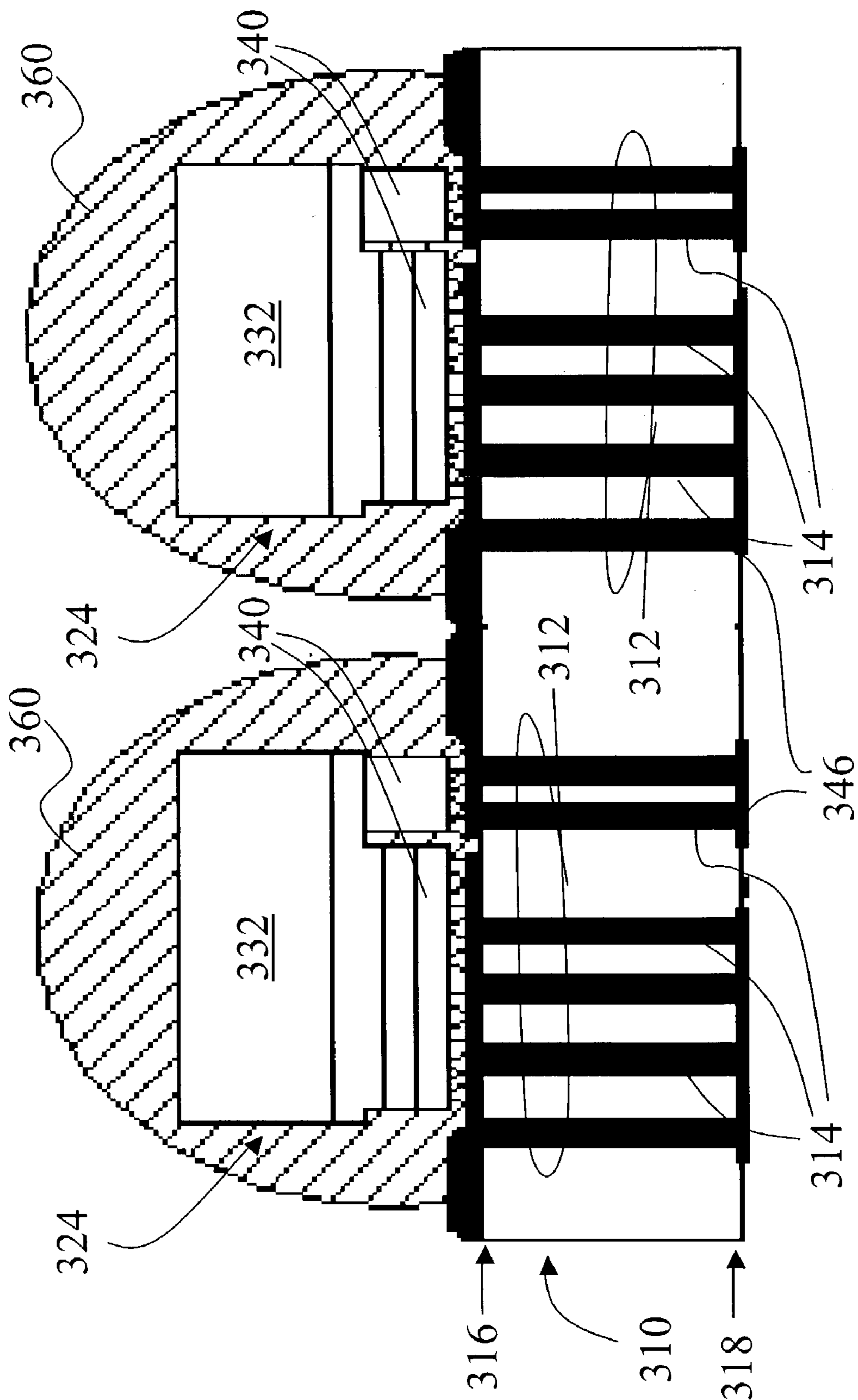

FIG 5

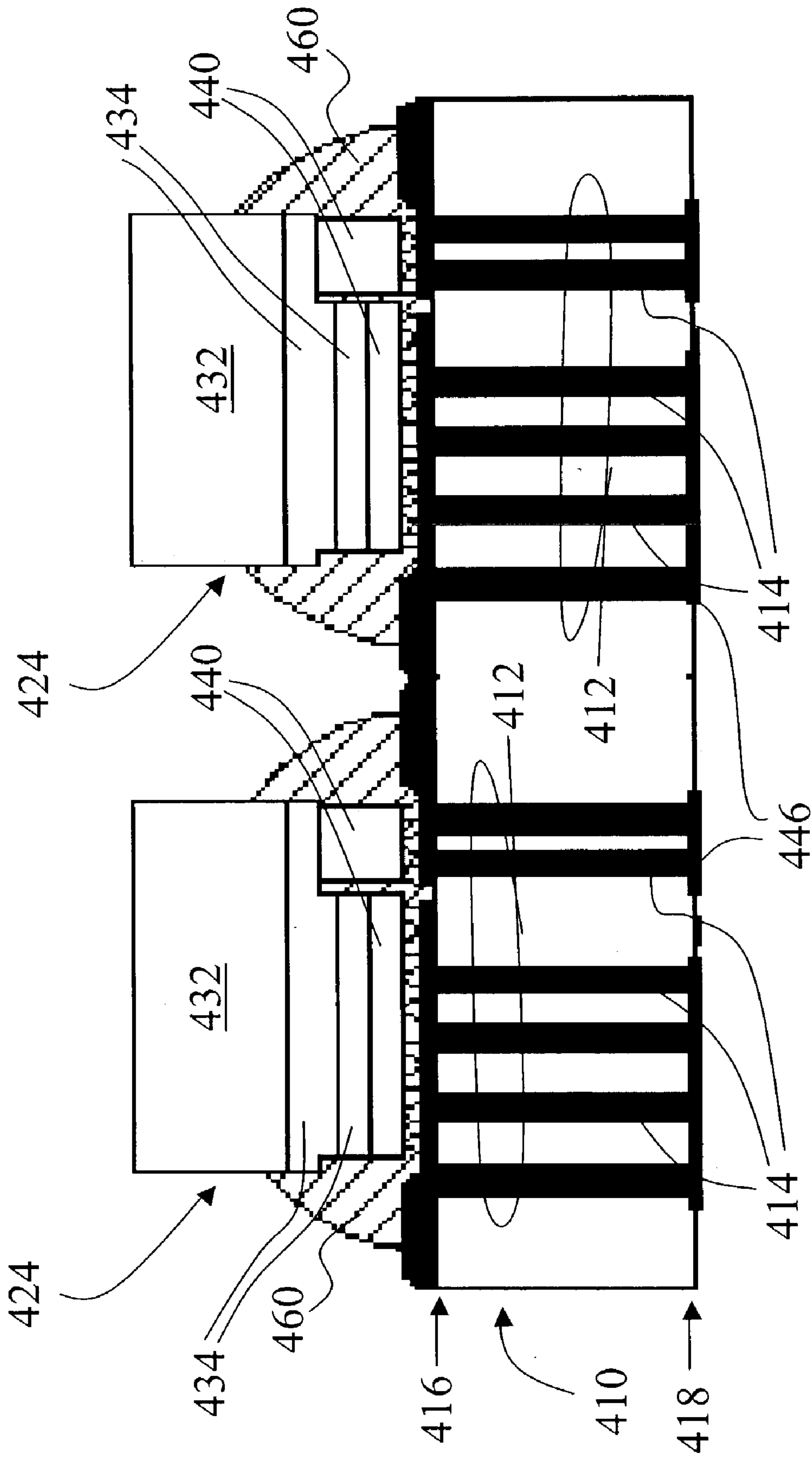

FIG 6

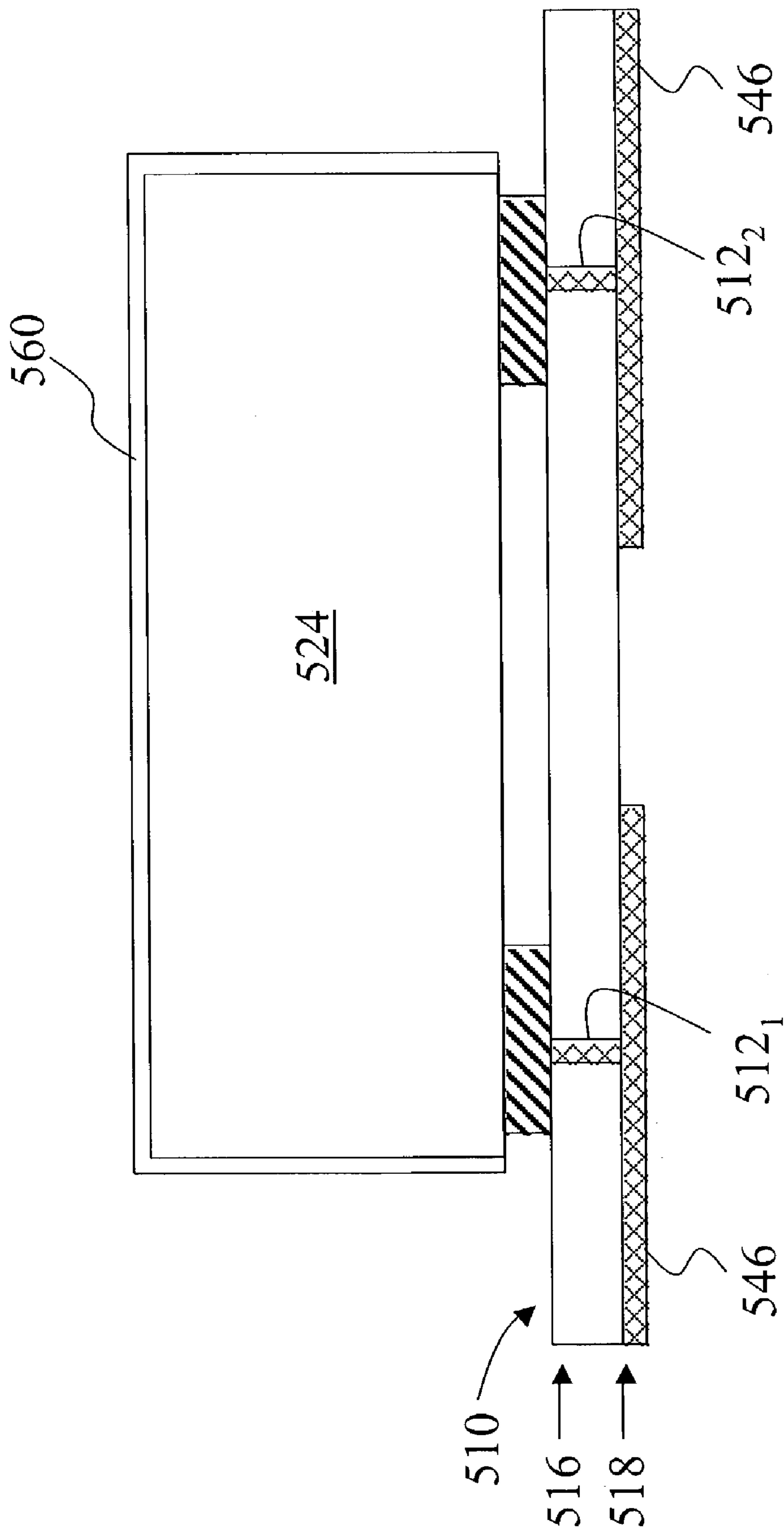

FIG 7

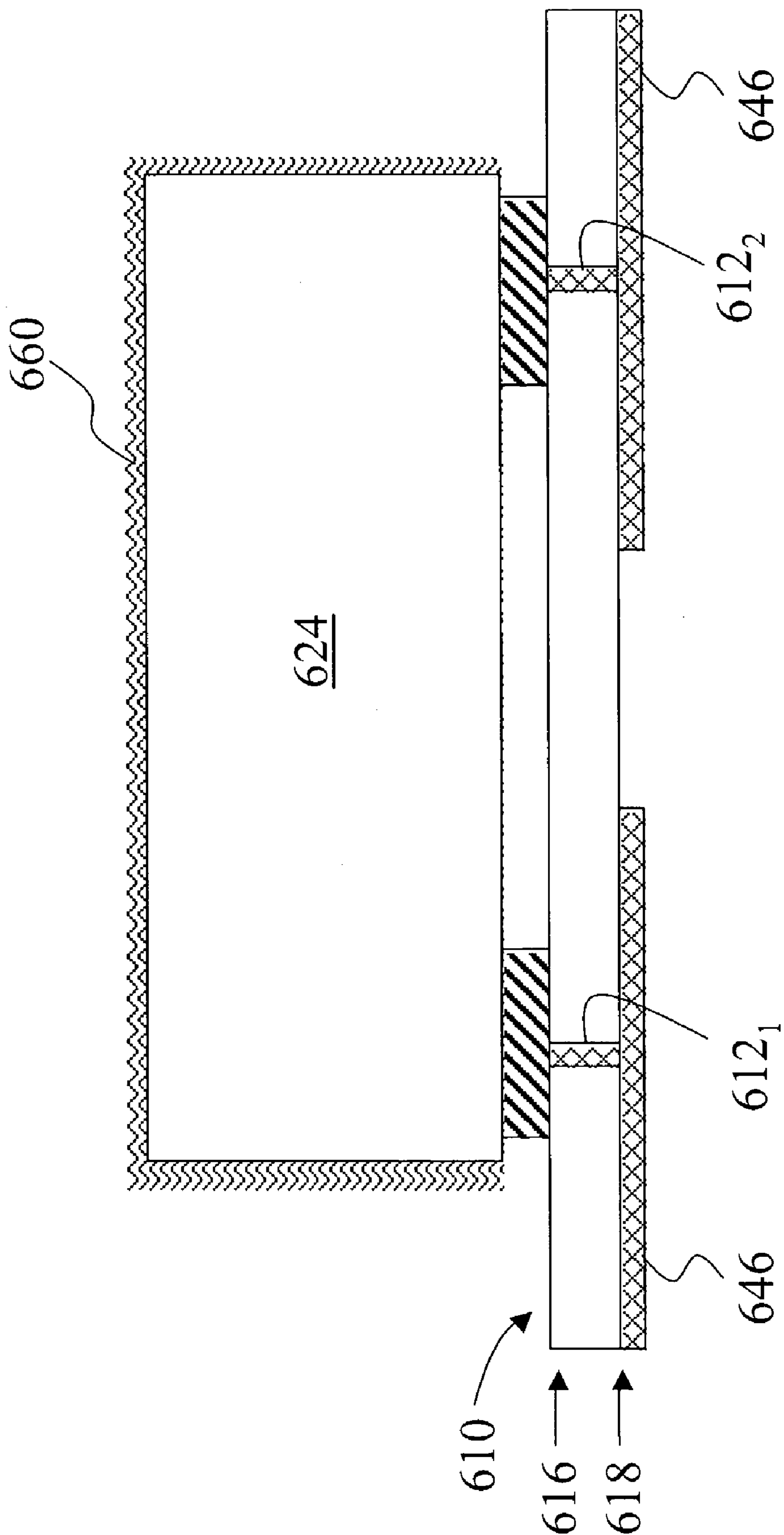

FIG 8

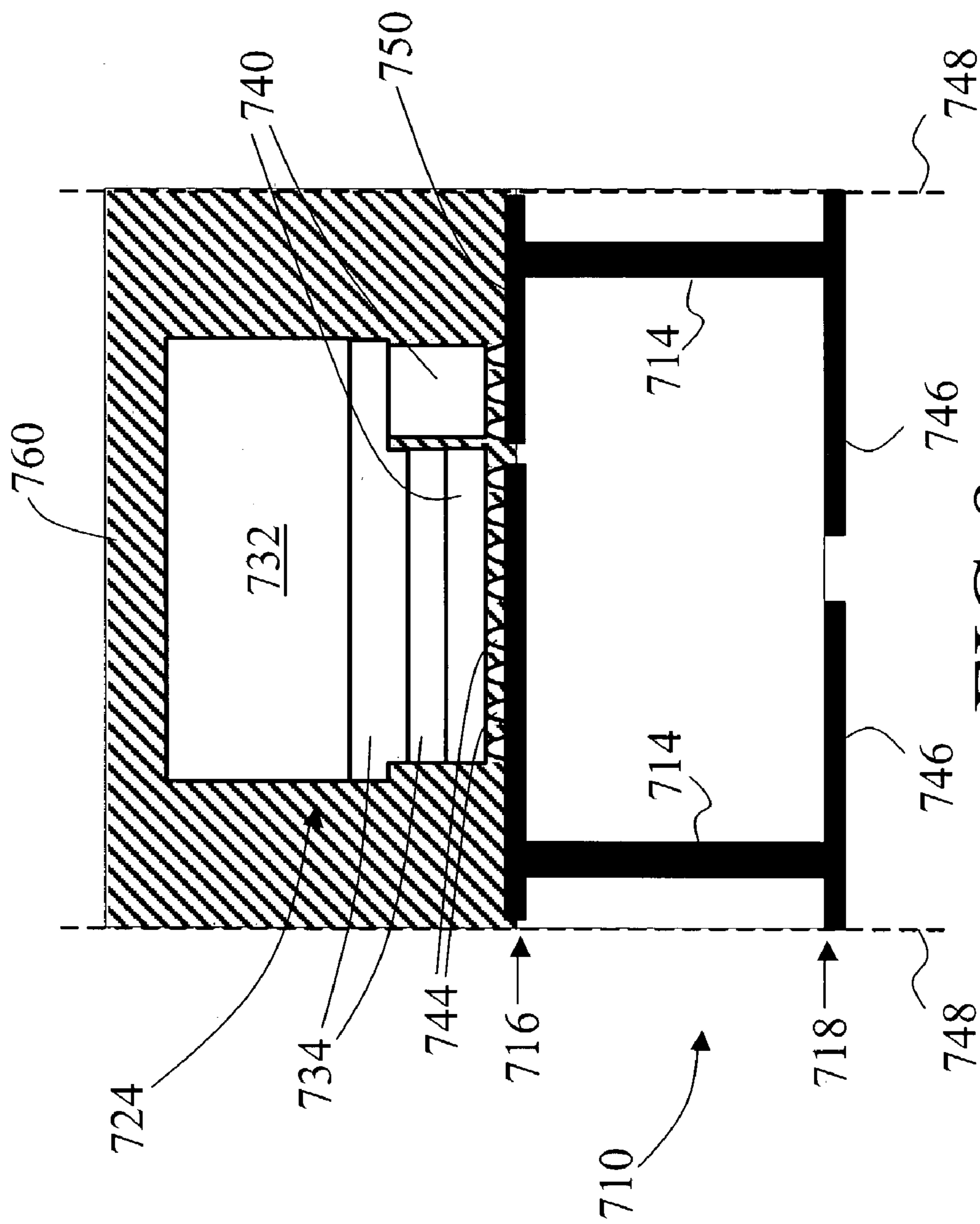
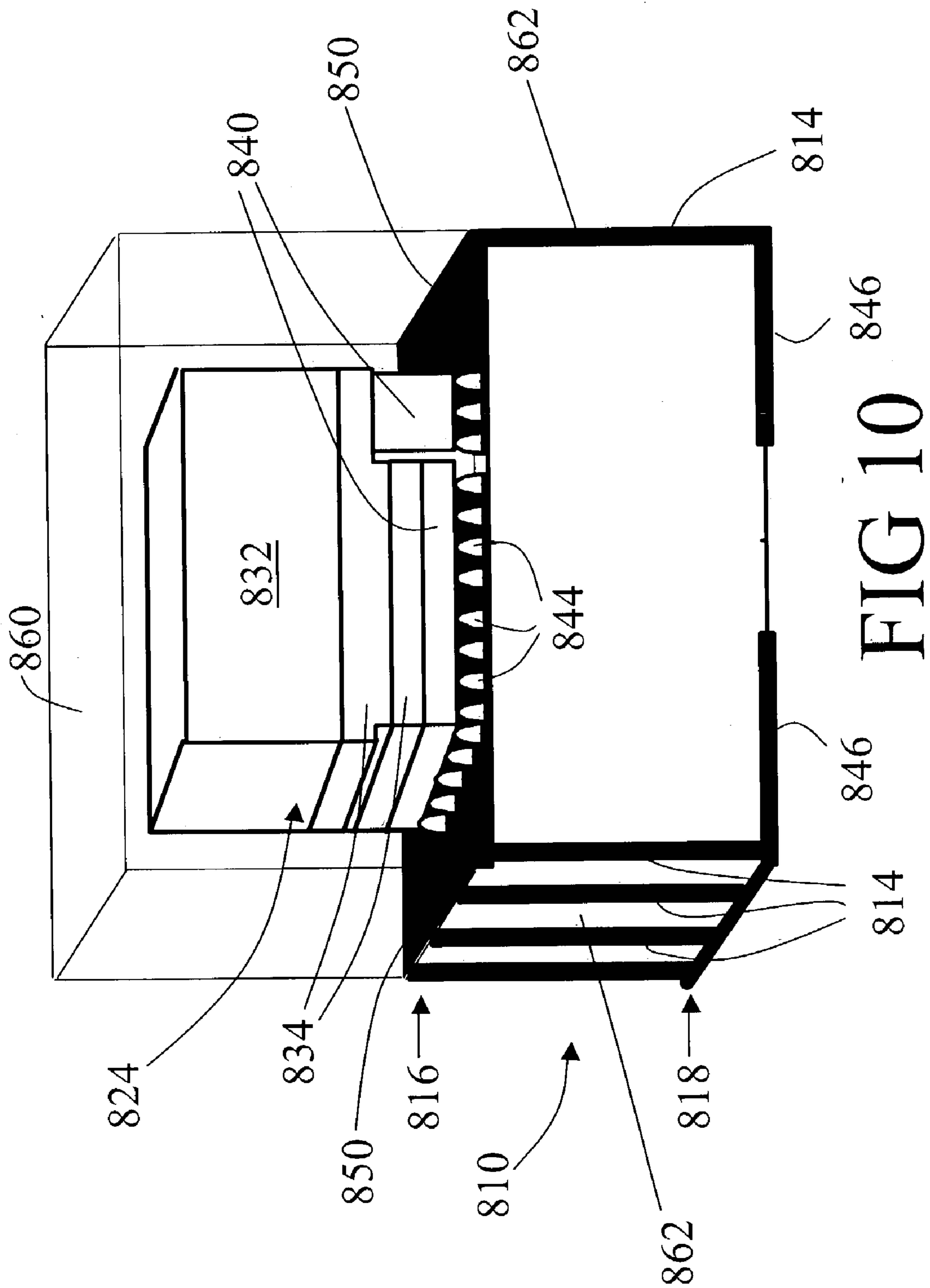

FIG 9



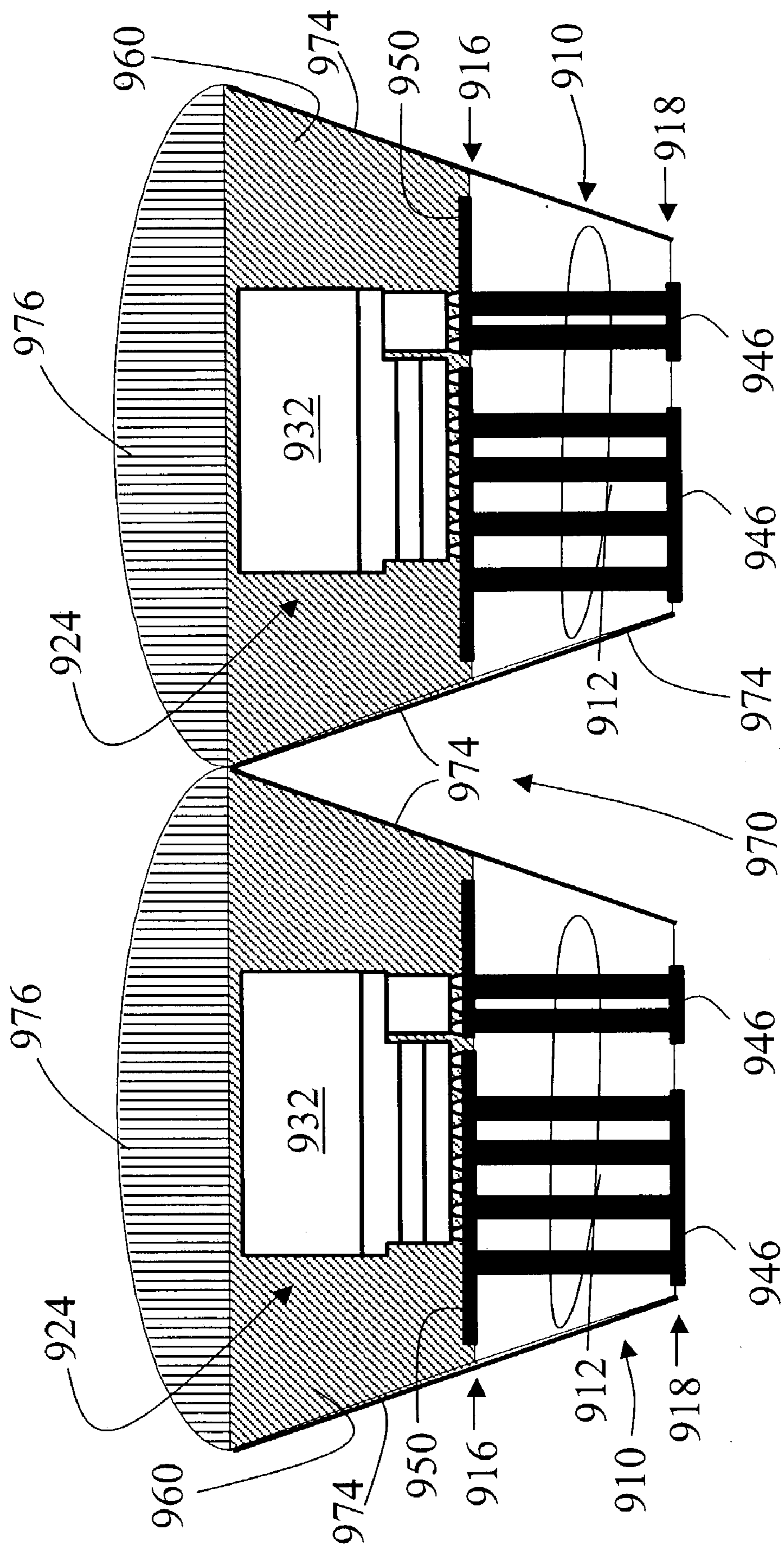

FIG 11

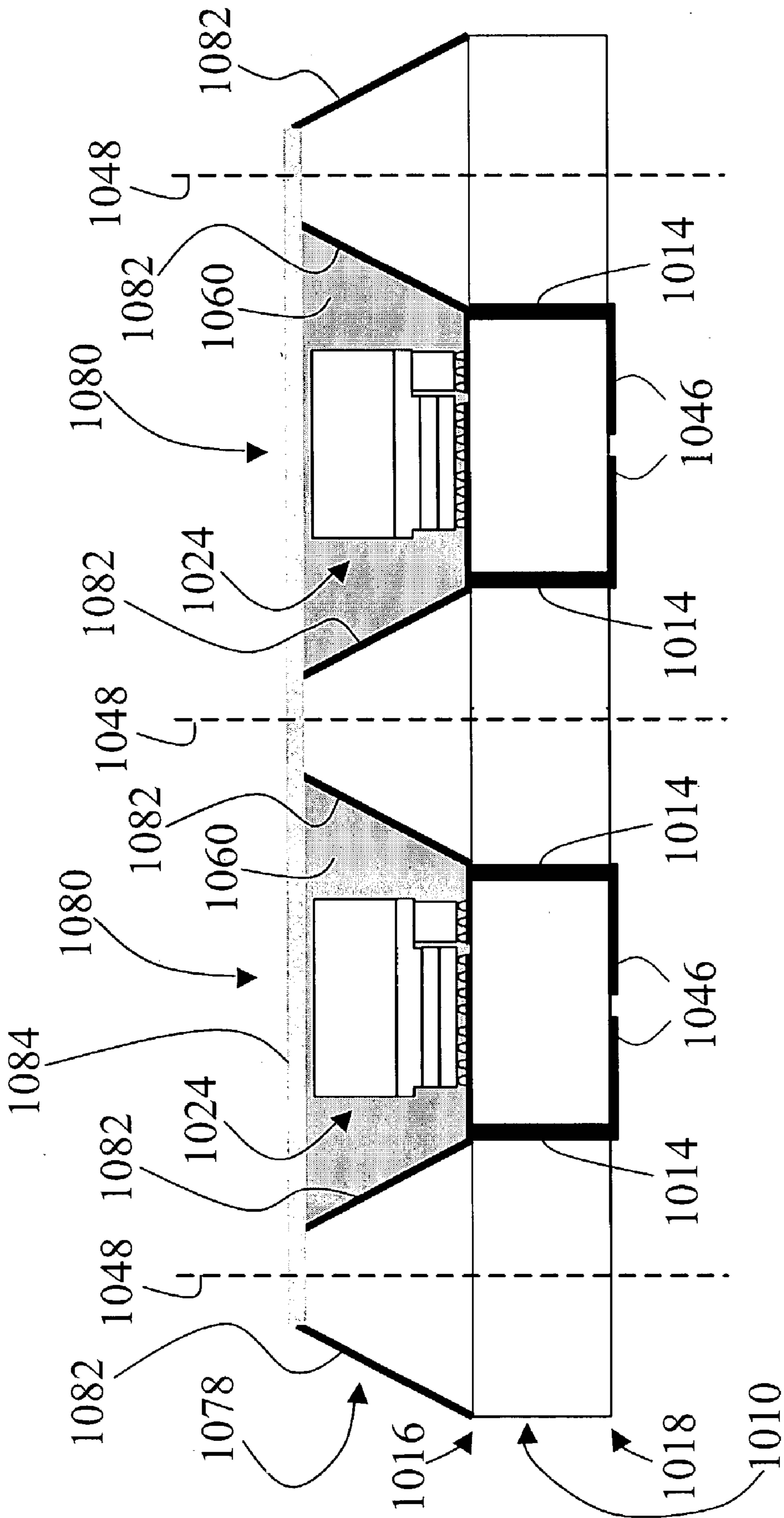

FIG 12

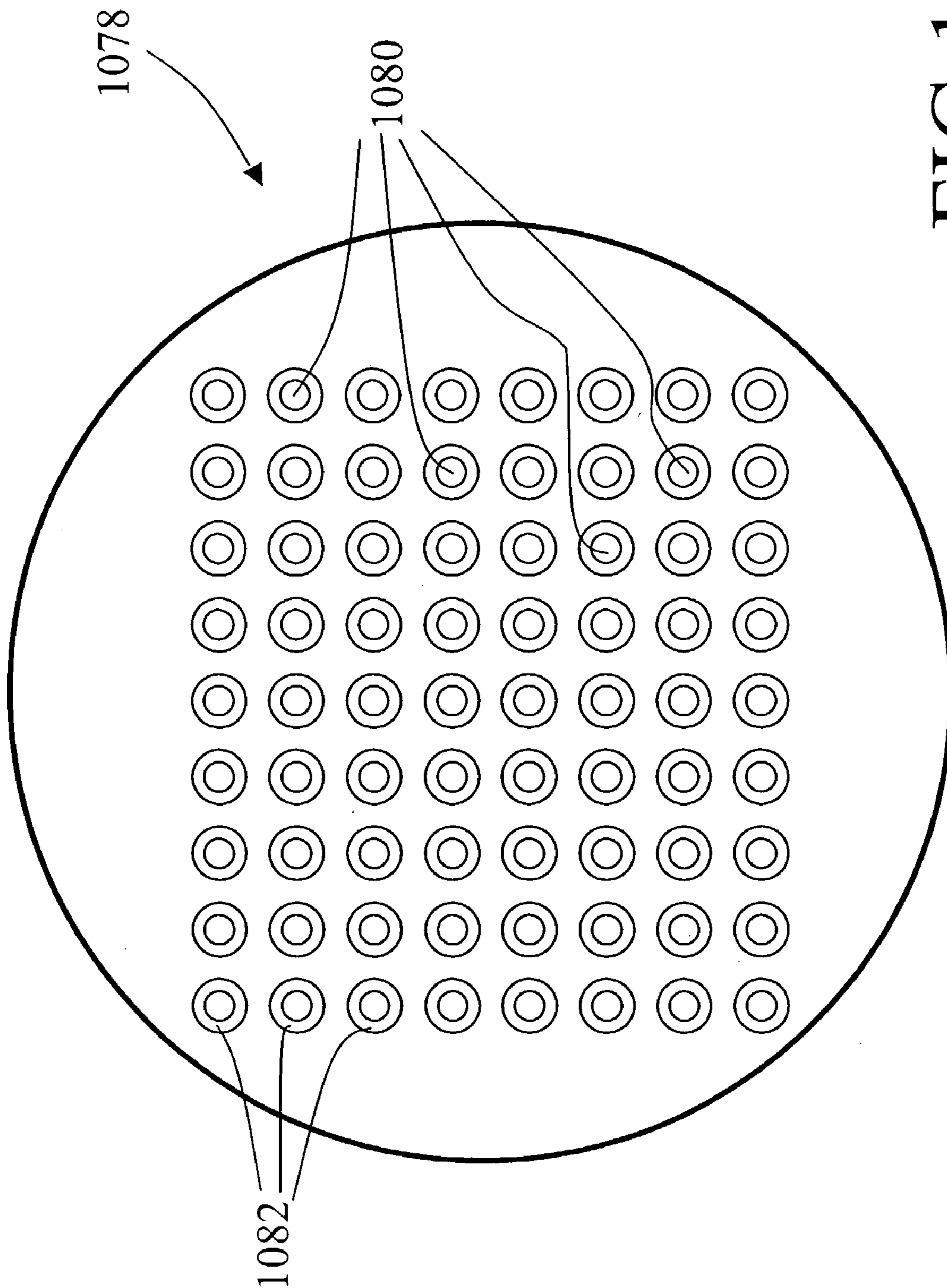

FIG 13

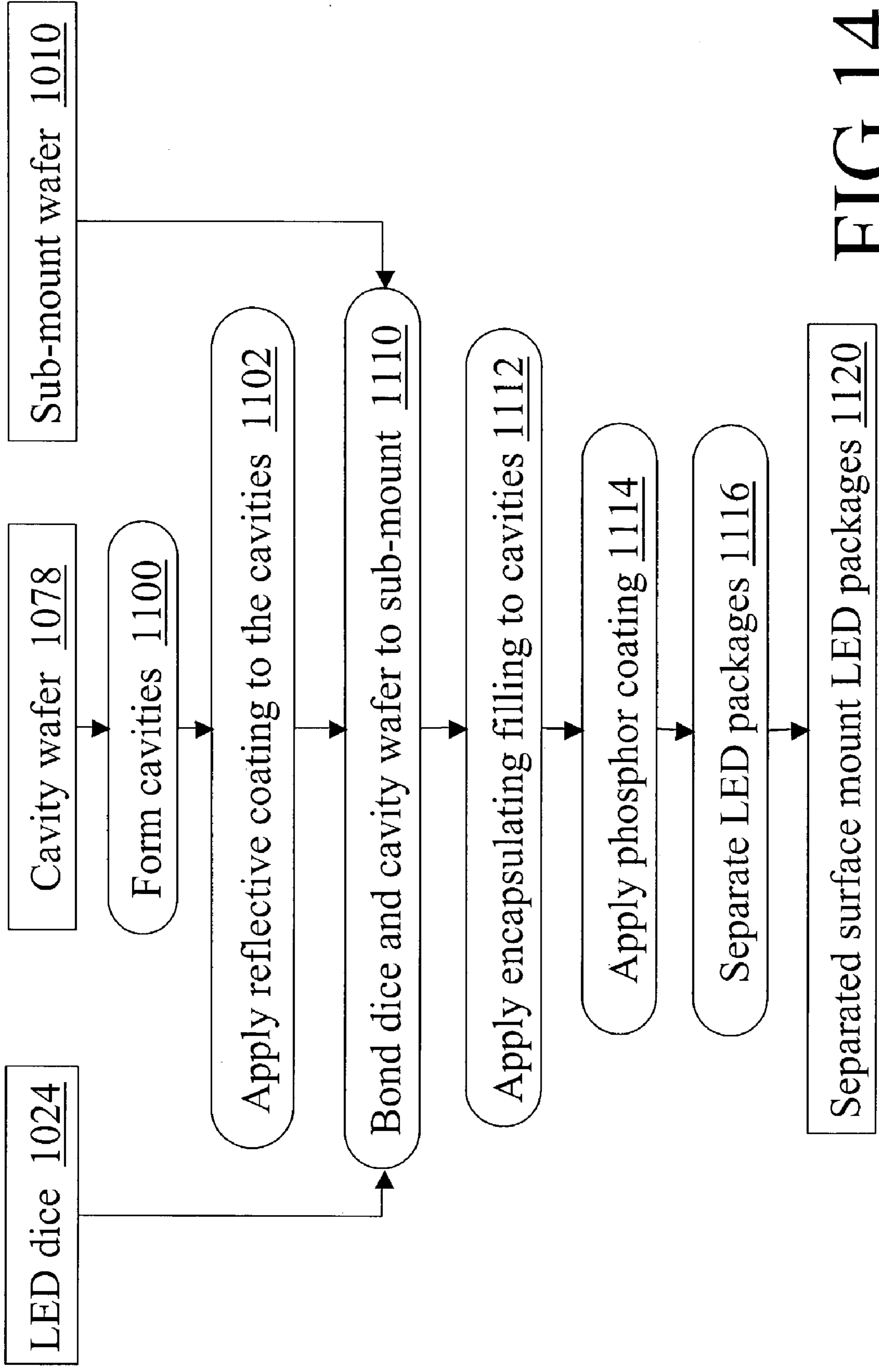

FIG 14

LED POWER PACKAGE**BACKGROUND OF THE INVENTION**

[0001] The present invention relates to the lighting arts. It is particularly applicable to the fabrication of high-brightness gallium nitride (GaN) based light emitting diodes (LEDs) and LED arrays, and will be described with particular reference thereto. However, the invention also finds application in connection with other types of LEDs and in other LED applications.

[0002] LEDs, particularly those fabricated from gallium nitride (GaN), aluminum nitride (AlN), indium nitride (InN), and various alloys and layer combinations thereof, are suitable for illumination applications in the ultraviolet and blue wavelength ranges. Additionally, GaN-based LEDs which are coated with a wavelength-converting phosphor are suitable for producing white or selectably colored light for illumination. Such LEDs have a number of advantages over other types of illuminators, including compactness, low operating voltages, and high reliability.

[0003] However, GaN-based power LEDs for lighting applications suffer from low luminous output. A state-of-the-art GaN-based LED presently dissipates about 5watts while generating about 100 lumens. In contrast, a typical incandescent light source dissipates about 60 watts while generating about 1,000 lumens of light output. Heat dissipation is a limiting factor in the luminous output and reliability of power LEDs. Although heat sinks provide for heat removal in LED-based lighting systems, there remains a need for improved heat removal from the active region of the LED die to the heat sink.

[0004] In a conventional GaN-based LED package, the active GaN layers are arranged on a sapphire or other transparent substrate in a flip-chip orientation in which the active GaN layers are bonded to a silicon or other thermally conductive sub-mount which in turn is supported on a lead frame or a printed circuit board. The silicon sub-mount is insulating and includes bonding pads that connect with electrodes of the LED die during the flip-chip bonding. The bonding pads of the silicon sub-mount are electrically connected with the lead frame or traces of the printed circuit board by wire-bonding. Light emitted by the GaN layers is transmitted through the transparent LED substrate, while heat produced by the GaN layers is conducted through the silicon sub-mount to a heat sink integrated into or associated with the lead frame or printed circuit board.

[0005] The conventional GaN-based LED package suffers from a number of disadvantages. Packaging is complex due to the separate steps of bonding the GaN layers to the sub-mount, bonding the sub-mount to the associated support, and wire-bonding the bonding pads to the lead frame. The package is incompatible with wafer-level processing typically employed in other areas of the electronics industry, which impacts production throughput and yield. Although some wafer level processing can be performed on the epitaxial GaN wafer prior to dicing, certain processes such as die encapsulation cannot be performed prior to dicing. Thermal conductivity, while improved by using the silicon sub-mount, is still non-ideal. The overall package is bulky.

[0006] The present invention contemplates an improved apparatus and method for forming the same that overcomes the above-mentioned limitations and others.

BRIEF SUMMARY

[0007] In accordance with one aspect, a method is provided for producing a plurality of surface mount light emitting diode (LED) packages. A plurality of light emitting diode (LED) dice are fabricated. Each LED die includes light emitting semiconductor layers disposed on a light-transmissive substrate, and frontside p-type and n-type contacts disposed on the semiconductor layers opposite the light-transmissive substrate. A plurality of arrays of openings are drilled into an electrically insulating sub-mount wafer. A metal is applied to the drilled openings to produce a plurality of via arrays. The LED dice are flip-chip bonded onto a frontside of the sub-mount wafer. The p-type and n-type contacts of each flip-chip bonded LED electrically communicate with a solderable backside of the sub-mount wafer through a via array. A thermal conduction path is provided for thermally conducting heat from the flip-chip bonded LED dice to the solderable backside of the sub-mount wafer. Subsequent to the flip-chip bonding, the sub-mount wafer is separated to produce surface mount LED packages each including at least one LED die.

[0008] In accordance with another aspect, a light emitting diode (LED) package is disclosed. An LED has a first side on which a pair of electrical contacts are arranged and a second side. A submount has a first side onto which the first side of the LED is bonded and a second side. Said submount provides: a plurality of electrically conductive paths that extend from the second side of the submount to the first side of the submount, said electrically conductive paths connecting with the electrical contacts of the LED such that electrical power is deliverable to the LED from the second side of the submount; and one or more thermally conductive paths that extend from the first side of the submount to the second side of the submount such that heat generated by the LED is removable therefrom from the second side of the submount.

[0009] In accordance with yet another aspect, a light emitting diode (LED) package is disclosed. An LED includes electrical contacts arranged on a surface thereof. An electrically insulating sub-mount has: (i) a frontside including printed circuitry contacting the LED electrical contacts; (ii) a backside including electrical contact pads; and (iii) electrically conductive paths passing through the insulating sub-mount and connecting the printed circuitry of the frontside with the electrical contact pads of the backside to deliver electrical power from to the back-side sub-mount contact pads to the LED.

[0010] In accordance with still yet another aspect, a method for constructing a plurality of light emitting diode (LED) packages is provided. A plurality of LEDs are flip-chip bonded to a frontside of an electrically insulating sub-mount wafer. The sub-mount wafer includes front-side contacts that electrically contact electrodes of the LED during the flip-chip bonding, and electrically conductive paths that electrically connect the front-side contacts with solderable contact pads arranged on a backside of the sub-mount wafer. At least one wafer-level processing operation is performed on the sub-mount wafer with the LEDs flip-chip bonded thereto. The sub-mount wafer is separated to produce the plurality of LED packages. Each LED package contains at least one of the plurality of LEDs.

[0011] Numerous advantages and benefits of the present invention will become apparent to those of ordinary skill in the art upon reading and understanding the following detailed description.

BRIEF DESCRIPTION OF THE DRAWINGS

[0012] The invention may take form in various components and arrangements of components, and in various steps and arrangements of steps. The drawings are only for purposes of illustrating preferred embodiments and are not to be construed as limiting the invention. Further, it is to be appreciated that the LED drawings are not to scale.

[0013] **FIG. 1A** shows a frontside view of a sub-mount wafer including a plurality of arrays of electrical vias, and dashed lines indicating separation planes for separating individual LED packages.

[0014] **FIG. 1B** shows a backside view of the sub-mount wafer of **FIG. 1A** including solderable contact pads and dashed lines indicating separation planes for separating individual LED packages.

[0015] **FIG. 1C** shows a frontside view of one of array of electrical vias with dashed lines indicating separation planes for separating the LED package.

[0016] **FIG. 1D** shows a backside view (looking through the transparent substrate) of an LED die that flip-chip bonds to the vias array of **FIG. 1C**. Electrodes on the frontside of the LED die are shown in phantom.

[0017] **FIG. 1E** shows a side sectional view of two LED dice of the type shown in **FIG. 1D** flip-chip bonded to two via arrays of the type shown in **FIG. 1C**.

[0018] **FIG. 2** shows a suitable processing flow diagram for manufacturing LED dice and a sub-mount wafer with vias arrays formed therein.

[0019] **FIG. 3** shows a side sectional view of an LED package that includes a third sub-array of vias which are designated thermally conductive vias.

[0020] **FIG. 4** shows a suitable method for combining the LED dice and sub-mount wafer components fabricated in accordance with the processing of **FIG. 2** to produce separated LED packages.

[0021] **FIG. 5** shows a side sectional view of two LED dice flip-chip bonded to two via arrays with molded material applied to each LED die in a step-and-repeat fashion.

[0022] **FIG. 6** shows a side sectional view of two LED dice flip-chip bonded to two via arrays with underfill material applied to each LED die in a step-and-repeat fashion.

[0023] **FIG. 7** shows a side sectional view of an LED die flip-chip bonded to an array of vias, with an optical coating applied to the LED die in a wafer-level process applied to the sub-mount wafer with the LEDs flip-chip bonded thereto.

[0024] **FIG. 8** shows a side sectional view of an LED die flip-chip bonded to an array of vias, with a contoured refractive surface etched on the LED die substrate using a wafer-level process applied to the sub-mount wafer with the LEDs flip-chip bonded thereto.

[0025] **FIG. 9** shows a side sectional view of an LED die flip-chip bonded to an array of vias arranged outside the

lateral area of the LED die, with a die-encapsulating epoxy applied in a wafer-level process prior to separation of the individual LED packages.

[0026] **FIG. 10** shows a perspective view of an LED die flip-chip bonded to an array of vias arranged outside the lateral area of the LED die, in which the LED package is separated by cutting through the via array to produce conductive sidewalls. A die-encapsulating epoxy is applied in a wafer-level process prior to separation of the individual LED packages.

[0027] **FIG. 11** shows a side sectional view of an LED die flip-chip bonded to an array of vias arranged outside the lateral area of the LED die. A die-encapsulating epoxy is applied in a wafer-level process, followed by a step-and-repeat bonding of transfer molded lenses, and the LED packages are separated along the "V"-shaped grooves.

[0028] **FIG. 12** shows a side sectional view of two LED dice flip-chip bonded to arrays of vias, with a cavity wafer bonded to the sub-mount wafer. The cavity wafer is arranged on the sub-mount wafer so that reflective cavities formed therein receive the LED dice, and each cavity is filled in step-and-repeat fashion with an encapsulant.

[0029] **FIG. 13** shows an frontside view of the cavity wafer of **FIG. 12** with cavities fabricated therein, prior to bonding onto the sub-mount wafer.

[0030] **FIG. 14** shows a suitable method for fabricating the cavity wafer of **FIGS. 12 and 13** and for combining the cavity wafer with LED dice and sub-mount wafer components fabricated in accordance with the processing of **FIG. 2** to produce separated LED packages.

DETAILED DESCRIPTION OF THE PREFERRED EMBODIMENTS

[0031] With reference to **FIGS. 1A-1E**, a plurality of surface mount light emitting diode (LED) packages are produced using a common sub-mount wafer **10** that includes arrays **12** of electrically conductive vias **14** that pass from a frontside **16** of the sub-mount wafer **10** to a backside **18** of the sub-mount wafer **10**.

[0032] LED dice **24** each include a light transmissive substrate **32** on which p-type and n-type semiconductor layers **34** are deposited to form a light emitting p/n diode structure that emits light when electrically energized. Metallic, polymeric, or another type of p-type and n-type electrodes **40** are formed on the semiconductor layers **34** for electrically energizing the LED die **24**. In one preferred embodiment, the LED dice **24** are GaN-based LEDs in which the semiconductor layers **34** are a multiple layer stack of AlN, GaN, InN, or alloys thereof which are deposited on a light-transmissive sapphire or SiC substrate. Although two semiconductor layers **34** are shown, it should be appreciated that a more complex semiconductor multi-layer stack of either an n-on-p or a p-on-n configuration can be employed. For example, the multi-layer stack can include AlN or AlGaIn epitaxial buffers, optical claddings, InN or InGaIn quantum wells, or the like. Moreover, the semiconductor layers **34** can be other than nitride layers and the substrate **34** can be made of other materials, such as an LED die including phosphide-based semiconductor layers on a wide bandgap, light transmissive semiconductor substrate.

[0033] The LED dice **24** are flip-chip bonded to the frontside **16** of the sub-mount wafer **10** to electrically contact the vias arrays **12**. Specifically, the electrodes **40** of each LED die **24** are thermosonically bonded to bonding bumps **44** disposed on frontside ends of the conductive vias **14** or on printed circuitry **50** that electrically communicates with the vias **14**. Backside ends of the conductive vias **14** electrically communicate with solderable contact pads **46** which are suitable for soldering the LED package to a printed circuit board or other support as a surface mount LED package. Electrical power applied to the contact pads **46** is conducted by the vias **14** and the bonding bumps **44** to the electrodes **40** of the LED dice **24**.

[0034] After the LED dice **24** are flip chip bonded, the sub-mount wafer **10** is preferably separated along separation planes **48** (shown as dashed lines in FIGS. **1A**, **1B**, and **1C**) to produce separated surface mount LED packages each including a flip-chip bonded LED die **24** and a vias array **12**.

[0035] Optionally, more than one LED die **24** is included in each separated LED package. For example, FIG. **1E** two LED dice **24** are included in a single package. In this case, electrical connecting printed circuitry **50** can be deposited on the frontside **16** of the sub-mount wafer **10**. (Note, the printed circuitry **50** is omitted in FIGS. **1A** and **1C**). Alternatively, the printed circuitry **50** can be omitted and the backside contact pads **46** of each vias array **12** of the multiple LED die package are separately electrically contacted to energize the plurality of LED dice.

[0036] With continuing reference to FIGS. **1A-1E** and with further reference to FIG. **2**, a suitable method **60** for fabricating the LED dice **24** includes depositing **62** the LED device semiconductor layers on the light transmissive substrate wafer **32**. For GaN-based LED dice fabrication, the depositing **62** is suitably performed by metal-organic chemical vapor deposition (MOCVD), molecular beam epitaxy (MBE), or another epitaxial deposition technique. Wafer level processing **64** by photolithography, wet chemical etching, plasma etching, and the like is performed to define device mesas, expose buried semiconductor layers, and so forth. Wafer-level metallization **66** performed in conjunction with lithographic definition of metallization areas is used to form the electrodes **40**. In one preferred embodiment, the electrodes **40** are principally gold, optionally disposed on a titanium adhesion layer and/or a nickel diffusion barrier layer. The wafer is diced **68** to separate the individual LED die **24**.

[0037] With continuing reference to FIGS. **1A-2**, a suitable method **80** for fabricating the sub-mount wafer **10** including the vias arrays **12** starts with a suitable electrically insulating wafer **82**. Electrically insulating sub-mount materials can be chosen from ceramics such as alumina, BeO, AlN, and the like, or composites such as AlSiC, graphite-filled polymers, or the like. Openings for the vias **14** are drilled **84** mechanically, by laser drilling, by photolithographic wet chemical etching, or the like. The vias are formed **86** by filling the openings with an electrically conductive material, preferably copper. The filling can be done using masked electroplating or other high-speed deposition, or by using a programmed step-and-repeat injection nozzle. Suitable via materials include metals such as silver, copper, gold, aluminum, platinum, palladium, tungsten, alloys thereof, or the like. Optionally, rather than filling the

openings, the via material can be electroplated or otherwise deposited on sidewalls of the openings.

[0038] In metallization processing **88**, **90**, the solderable back contact pads **46** and optional frontside printed circuitry **50** is photolithographically defined and applied. Since the wafer **82** is electrically insulating, these metallizations can be deposited directly to onto the wafer **82**. Optionally, a silicon nitride or other insulating layer is first deposited on the wafer **82** to provide further electrical isolation.

[0039] The bonding bumps **44** are formed **92** on the frontside ends of the electrically conductive vias **14** or on the printed circuitry **50**. In one embodiment, solder bumps are employed. However, typical solders for flip chip bonding have thermal conductivities of about 25-60 W/mK and bump heights greater than 1 mil (25 microns). The large height and relatively low thermal conductivity limits thermal heat sinking via the solder bonding bumps.

[0040] Hence, in a preferred embodiment, the bonding bumps **44** are made principally of copper, and thermosonic flip chip bonding is used. Typical copper thermal conductivities are about 400 W/mK, and copper bump heights of less than 0.5 mils (13 microns) are obtainable. The increased thermal conductivity and lower bump height compared with solder bumps reduces thermal impedance. However, there is typically a tradeoff in that larger bonding bump heights promote reliability, while lower bonding bump heights reduce thermal resistance of the bumps. In one preferred embodiment, about 1 mil (25 microns) copper bumps are used. In the illustrated embodiment, the bonding bumps **44** are formed on the printed circuitry **50**. Alternatively, however, bonding bumps for thermosonic bonding can be formed on the light emitting diodes.

[0041] In one suitable approach for forming the bonding bumps **44**, the frontside ends of the vias **14** or the printed circuitry **50** on which the bonding bumps are to be formed are terminated in a thin titanium layer. To prepare the surface, this terminating titanium layer is partially or completely etched away just prior to bumps formation **92**. A thin seed layer such as 20 nm titanium/150 nm copper is deposited, and the copper bumps positions are photolithographically defined. The copper bumps are electroplated onto the exposed areas of the seed layer. The photolithographic mask is removed, and the thin seed layer etched off.

[0042] The copper bumps are preferably lithographically coated with gold to promote the thermosonic bonding. Optionally, a titanium layer is deposited onto the copper bumps before applying the gold coating to promote gold adhesion. A thermosonic gold-to-gold bond between the bonding bumps **44** and the electrodes **40** is formed by heating the substrate **10** to about 150° C. with the bonding bumps **44** contacting corresponding gold surfaces of the electrodes **40** of the light emitting diodes **24**. Upon application of ultrasonic energy, the thermosonic bond forms. Advantageously, this thermosonic bond forms at about 150° C., but provides a die-attachment that is thereafter thermally stable up to about 600° C.

[0043] The vias arrays **12** of the sub-mount **10** of FIGS. **1A-1E** each include a first vias sub-array **12₁**, of electrically conductive vias **14** that contact the first (p-type or n-type) electrode **40**, and a second vias sub-array **12₂** of electrically conductive vias **14** that contact the second (n-type or p-type)

electrode **40**. Heat sinking occurs through the electrically conductive vias **14** of the sub-arrays **12₁**, **12₂**. The vias **14** are spatially distributed within each sub-array **12₁**, **12₂** to provide generally uniform heat sinking of the attached LED die **24**. Alternative or additional heat sinking can be provided by the sub-mount **10**, if the sub-mount **10** is formed of a thermally conductive material. For example, AlN provides substantial thermal conduction for heat sinking.

[0044] With reference to **FIG. 3**, an LED package with a designated heat sinking vias through the sub-mount is described. In the LED package of **FIG. 3**, components that correspond to substantially similar components of the LED package of **FIGS. 1A-1E** are indicated with reference numbers offset by a factor of 100, e.g. an LED die **124** in **FIG. 3** corresponds with the LED die **24** of **FIGS. 1A-1E**. The LED package of **FIG. 3** has smaller electrical contacting regions connecting with the vias sub-arrays **112₁**, **112₂** which provide limited heat sinking. A sub-mount **110** in combination with the vias sub-arrays **112₁**, **112₂** is not thermally conductive enough to provide adequate and substantially uniform heat sinking for the LED die **124**.

[0045] To provide additional heat sinking, a third vias sub-array **112₃** of designated heat sinking vias is provided. The vias of the third vias sub-array **112₃** do not electrically contact the LED die **124**, and do not contribute to electrical energizing of the LED die **124**. The vias of the third vias sub-array **112₃** are thermally conductive, but can be electrically conductive or electrically insulating. The vias sub-array **112₃** is suitably formed similarly to the process operations **84**, **86** that form the electrical vias. Frontside ends of the thermal vias sub-array **112₃** thermally communicate with a thermally conductive underfill material **160** disposed between the LED die **124** and the sub-mount **110** to provide thermal contact between the LED die **124** and the designated thermal vias sub-array **112₃**. A thermally conductive pad **162** contacting backside ends of the thermal vias sub-array **112₃** provides thermal contact with the printed circuit board or other support on which the surface mount LED package is arranged.

[0046] With continuing reference to **FIGS. 1A-2** and with further reference to **FIG. 4**, a suitable method **200** for combining the LED dice **24** formed by the exemplary process **60** with the sub-mount wafer **10** formed by the exemplary process **80** is described. The LED dice **24** are flip chip bonded **202** to the sub-mount **10**. In the preferred embodiment that employs copper bonding bumps **44**, thermosonic bonding is preferably employed. Thermosonic bonding advantageously effects bonding at low wafer temperatures of about 150° C., and the thermosonic bond is thereafter thermally stable up to about 600° C. Alternatively, standard soldering methods can be used.

[0047] With the LED dice **24** attached to the sub-mount **10**, sub-mount wafer level dice processing **206**, such as application of optical coatings, backside substrate processing, step-and-repeat application of LED dice encapsulants, or the like, is optionally performed. Sub-mount wafer level processing beneficially processes all the dice **24** simultaneously or in a convenient step-and-repeat arrangement. Moreover, the sub-mount wafer can be sized to be received and processed by conventional automated silicon processing systems that may not be able to receive and manipulate the undiced LED substrate wafer **32**. Furthermore, certain pro-

cesses, such as LED die encapsulation, cannot be performed prior to die attachment. After the optional sub-mount wafer level processing **206**, the sub-mount wafer is sawed, diced, or otherwise cut along the separation planes **48** to produce separated surface mount LED packages **210**. The separation can employ mechanical sawing, laser sawing, cleaving, or other suitable techniques.

[0048] With continuing reference to **FIG. 4** and with further reference to **FIG. 5**, an LED package including individual LED encapsulants **360** applied by sub-mount wafer level processing **206** is described. In the LED package of **FIG. 5**, components that correspond to substantially similar components of the LED package of **FIGS. 1A-1E** are indicated with reference numbers offset by a factor of 300, e.g. an LED die **324** in **FIG. 5** corresponds with the LED die **24** of **FIGS. 1A-1E**. In fabricating the LED package of **FIG. 5**, during the sub-mount wafer level processing **206** individual LED encapsulants **360** are applied to each LED die **324** and to a surrounding portion of the front surface **316** of the sub-mount **310** to hermetically seal the LED dice **324**. The individual encapsulants **360** are suitably applied using a step-and-repeat apparatus such as are employed in automated silicon device processing. The molded encapsulants **360** are preferably made of an epoxy or other encapsulant material that provides good refractive index matching with the LED substrate **332**, and is preferably also shaped to produce a selected lensing of the illumination output.

[0049] With continuing reference to **FIG. 4** and with further reference to **FIG. 6**, an LED package including individual LED underfill material **460** applied by sub-mount wafer level processing **206** is described. In the LED package of **FIG. 6**, components that correspond to substantially similar components of the LED package of **FIGS. 1A-1E** are indicated with reference numbers offset by a factor of 400, e.g. an LED die **424** in **FIG. 6** corresponds with the LED die **24** of **FIGS. 1A-1E**. In fabricating the LED package of **FIG. 6**, during the sub-mount wafer level processing **206** individual LED underfill material **460** is applied to the flip chip bonding interface of each LED die **424** to hermetically seal critical components of the LED dice **424** such as the semiconductor layers **434** and electrodes **440**. Preferably, the underfill material **460** is thermally conductive to contribute to heat sinking. The underfill material **460** is suitably applied using a step-and-repeat apparatus that sequentially processes each flip-chip bonded LED die **424**.

[0050] With continuing reference to **FIG. 4** and with further reference to **FIG. 7**, an LED package including an optical film **560** applied by sub-mount wafer level processing **206** is described. In the LED package of **FIG. 7**, components that correspond to substantially similar components of the LED package of **FIGS. 1A-1E** are indicated with reference numbers offset by a factor of 500, e.g. an LED die **524** in **FIG. 7** corresponds with the LED die **24** of **FIGS. 1A-1E**. In fabricating the LED package of **FIG. 7**, during the sub-mount wafer level processing **206** the optical coating **560** is applied to the light transmissive substrates of the LED dice **524**. The coating **560** can be an anti-reflection coating, a refractive index matching coating, a phosphor layer, or the like. The optical coating **560** can be applied using a step-and-repeat apparatus that sequentially processes each LED dice flip chip bonded to the sub-mount wafer **510**.

Alternatively, the optical coating **560** can be applied to the frontside **516** of the sub-mount wafer including the LED dice **524**. In this latter approach, the coating **560** also coats the sub-mount wafer **510**, unless the coating chemistry is such that the coating does not adhere to the submount wafer **510**.

[0051] With continuing reference to **FIG. 4** and with further reference to **FIG. 8**, an LED package includes a contoured refractive surface **660** providing a selected light refraction effect. The contoured refractive surface **660** is formed by the sub-mount wafer level processing **206**. In the LED package of **FIG. 8**, components that correspond to substantially similar components of the LED package of **FIGS. 1A-1E** are indicated with reference numbers offset by a factor of 600, e.g. an LED die **624** in **FIG. 8** corresponds with the LED die **24** of **FIGS. 1A-1E**. In fabricating the LED package of **FIG. 8**, during the sub-mount wafer level processing **206** a photolithographically or optically defined surface contouring pattern is formed in the transparent substrate of the LED die **624** by a suitable plasma etching, wet chemical etching, or the like. The contoured refractive surface **660** can include light-refractive prism features, a Fresnel lens pattern, or other selected light refraction contours.

[0052] With reference to **FIG. 9**, an LED package including a laterally continuous encapsulant film applied by the sub-mount wafer level processing **206**, as well as vias arranged outside a lateral area of the LED die, is described. In the LED package of **FIG. 9**, components that correspond to substantially similar components of the LED package of **FIGS. 1A-1E** are indicated with reference numbers offset by a factor of 700, e.g. an LED die **724** in **FIG. 9** corresponds with the LED die **24** of **FIGS. 1A-1E**. In fabricating the LED package of **FIG. 9**, during the sub-mount wafer level processing **206** a laterally continuous epoxy film or other encapsulating film **760** is applied to the sub-mount wafer **710**. The encapsulant film **710** encapsulates all LED dice **724** that are flip chip bonded to the sub-mount wafer **710** in a single film deposition process. When the sub-mount wafer is separated along separation planes **748** in the sub-mount separation process **208** of **FIG. 4**, the separating defines the side edges of the encapsulant **710** for each separated surface mount LED package.

[0053] With continuing reference to **FIG. 9**, the LED package there illustrated also includes electrical vias **714** arranged outside of a lateral area of the LED die **724**. The bonding bumps **744** are arranged on the printed circuitry **750** formed in the circuitry printing process **90** of **FIG. 2**, and the printed circuitry **750** connects the bonding bumps **744** with the vias **714**. The vias **714** in turn connect with contact pads **746** disposed on the backside **718** of the sub-mount wafer **710**. Preferably, in such an arrangement the sub-mount **710** provides the primary heat sinking pathway for the LED die **724**. A suitable thermally conductive sub-mount material is AlN. Arrangement of the vias **714** outside a lateral area of the LED die **724** advantageously provides a smooth surface for the flip chip bonding, which can be important for certain types of die attach processes.

[0054] With reference to **FIG. 10**, an LED package including a laterally continuous encapsulant film and vias arranged as sidewalls of the separated LED package is described. In the LED package of **FIG. 10**, components that correspond to

substantially similar components of the LED package of **FIGS. 1A-1E** are indicated with reference numbers offset by a factor of 800, e.g. an LED die **824** in **FIG. 10** corresponds with the LED die **24** of **FIGS. 1A-1E**. A wafer level encapsulant film **860** substantially similar to the encapsulant film **760** of **FIG. 8** is applied as a laterally continuous film during the sub-mount wafer level processing **206**.

[0055] Vias **814** are arranged outside a lateral area of the LED die **824**, with printed circuitry **850** electrically connecting bonding bumps **844** with the vias **814**. During the LED package separation process **208** of **FIG. 4** the individual surface mount LED packages are separated along separation planes that substantially coincide with a central axis of the vias **814**. Hence, the vias **814** are disposed on sidewalls **862** of the separated LED package. To facilitate separation, the via formation process **86** of **FIG. 2** preferably is limited to deposition of the electrically conductive via material onto sidewalls of the drilled openings. Arrangement of the vias **814** on sidewalls of the separated LED package beneficially improves structural reliability of the separated surface mount LED package as compared with other embodiments which include vias that pass through the sub-mount in the separated surface mount LED package. Preferably, an AlN or other thermally conductive sub-mount material is employed to provide primary heat sinking.

[0056] The LED packages of **FIGS. 9 and 10** include encapsulating films **760, 860** that are applied across the frontside **716, 816** of the sub-mount wafer **710, 810** during the sub-wafer level processing **206** of **FIG. 4**. The lateral edges or sidewalls of the encapsulant for each separated surface mount LED package is defined by the separation planes **748**, which are transverse to the frontside surface **716, 816** in the LED packages of **FIGS. 9 and 10**.

[0057] With reference to **FIG. 11**, a surface mount LED package with non-vertical separation planes is described. In the LED package of **FIG. 10**, components that correspond to substantially similar components of the LED package of **FIGS. 1A-1E** are indicated with reference numbers offset by a factor of 900, e.g. an LED die **924** in **FIG. 11** corresponds with the LED die **24** of **FIGS. 1A-1E**. The LED package shown in **FIG. 11** includes the LED die **924** with transparent substrate **932** flip chip bonded to the sub-mount **910** which has via arrays **912** electrically connecting printed circuitry **950** on the sub-mount frontside **916** with solderable bonding pads **946** on the sub-mount backside **918**. A planar encapsulant film **960** is applied similarly to the planar films **760, 860** of **FIGS. 9 and 10**.

[0058] However, rather than vertical separation planes **48** used in the LED package described with reference to **FIGS. 1A-1E**, the LED package of **FIG. 11** is separated using a "V"-shaped groove **970** cut from the backside **918** of the sub-mount wafer. After formation of the "V"-shaped grooves **970** but before LED package separation, reflective material is deposited on the backside **918** to form reflective coatings **974** on angled sides of the encapsulant **960** to define a reflector cup. The remaining sub-mount material is then fractured to separate the surface mount LED packages. Optionally, a transfer molded lens **976** is disposed on each surface mount LED package further improve light extraction.

[0059] With reference to **FIGS. 12 and 13**, a surface mount LED package with reflector cavities defined by a

cavity wafer is described. In the LED package of **FIG. 12**, components that correspond to substantially similar components of the LED package of **FIGS. 1A-1E** are indicated with reference numbers offset by a factor of 1000, e.g. an LED die **1024** in **FIG. 12** corresponds with the LED die **24** of **FIGS. 1A-1E**. The LED package shown in **FIG. 12** includes the LED die **1024** flip chip bonded to the sub-mount **1010** which has vias **1014** electrically connecting the LED die **1024** on the sub-mount frontside **1016** with solderable bonding pads **1046** on the sub-mount backside **1018**.

[0060] With continuing reference to **FIGS. 12 and 13** and with further reference to **FIG. 14**, a cavity wafer **1078** (a frontside of which is shown in **FIG. 13**) that defines reflector cavities is bonded to the frontside **1016** of the sub-mount wafer **1010**. The cavity wafer **1078** includes cavities **1080** each having a shape of a cut-off cone (that is, the cavities have a shape of a frustum of a cone). In one suitable embodiment, the cavity wafer **1078** is a silicon wafer and the slanted sides of the cavities **1080** are formed **1100** at a selected angle by drilling followed by anisotropic etching. A reflective material is applied **1102** to the frontside of the cavity wafer **1078** to form reflective layers **1082** on the slanted sides of the cavities **1080** that define the reflector cups. Instead of a reflective coating **1082**, a white ceramic cavity wafer without an optical coating can be used.

[0061] The LED dice **1024** and the cavity wafer **1078** with reflective cavities **1080** formed therein are bonded **1110** to the sub-mount wafer **1010**, with the flip chip bonded LED dice **1024** and the cavity wafer **1078** relatively positioned such that each reflector cavity **1080** receives one LED die **1024**. In a suitable encapsulation process **1112**, encapsulant material is dispensed on top of the bonded cavity wafer **1078** and urged into the cavities **1080** using a sponge, squeegee, or the like to form an encapsulating filling **1060**. Alternatively, an automated step-and-repeat encapsulant applicator can be used. Optionally, a phosphor coating **1084** is applied **1114** to the surface of the cavity wafer **1078** and the encapsulating filling **1060** to convert LED light, such as blue or ultraviolet GaN LED light, into a selected illumination such as white light. Individual surface mount LED packages **1120** are separated **1116** by sawing or cutting the sub-mount wafer **1010** and bonded cavity wafer **1078** along vertical separation planes **1048**.

[0062] The resulting LED packages **1120** are robust. Since the encapsulating filling **1060** is recessed in the cavities **1080**, a soft material such as silicone can be used as the encapsulant material. The reflector cup formed by the cavities **1080** improves light extraction, and the sub-mount wafer level deposition of the phosphor layer **1084** provides consistent phosphor thickness and uniformity compared with phosphorizing individual LED dice, giving improved color consistency that is substantially independent of direction. Optionally, a lens array (not shown) is applied using an automated step-and-repeat applicator prior to the separating **1116** to further improve light extraction.

[0063] The invention has been described with reference to the preferred embodiments. Obviously, modifications and alterations will occur to others upon reading and understanding the preceding detailed description. It is intended that the invention be construed as including all such modifications and alterations insofar as they come within the scope of the appended claims or the equivalents thereof.

1-7. (Canceled)

8. A light emitting diode (LED) package including:

an LED having (i) a first side, bounded by a perimeter, on which electrical contacts are arranged and (ii) a second side; and,

a submount having a first side onto which the first side of the LED is bonded and a second side, said submount providing a plurality of electrically conductive paths that extend from the second side of the submount to the first side of the submount, said electrically conductive paths including first electrically conductive vias located outside the perimeter and connecting with the electrical contacts of the LED such that electrical power is deliverable to the LED from the second side of the submount.

9-11. (Canceled)

12. The LED package of claim 8, wherein the first plurality of vias wrap around the outer surface of the submount.

13. The LED package of claim 8, wherein the submount is thermally conductive.

14. The LED package of claim 8, wherein the first plurality of electrically conductive vias are thermally conductive.

15. The LED package of claim 8, wherein the submount further includes:

a set of one or more thermally conductive vias distinct from the electrically conductive vias.

16. (Canceled)

17. The LED package of claim 8, wherein the submount includes:

a plurality of thermally and electrically conductive bumps formed on one of the first side of the submount and the LED, said bumps joining the LED and submount together by thermosonic bonding.

18. The LED package of claim 17, wherein the bumps are less than about 25 microns in height.

19. The LED package of claim 17, wherein the bumps include:

a metal core;

a barrier metal overcoating the metal core; and,

a bondable metal overcoating the barrier metal.

20. The LED package of claim 19, wherein the metal core is copper or aluminum, the barrier metal is nickel, and the bondable metal is gold.

21. The LED package of claim 8, further including:

a light transmissive material arranged on LED.

22. The LED package of claim 21, wherein the light transmissive material encapsulates the LED.

23. The LED package of claim 21, wherein the light transmissive material forms a lens.

24. The LED package of claim 23, wherein the lens is a Fresnel lens.

25. The LED package of claim 8, further including:

an antireflective coating on the LED, said antireflective coating aiding in extraction of light from the LED.

- 26.** The LED package of claim 8, further including:
a phosphor arranged to receive light of a first wavelength from the LED, and in response thereto emit light of a second wavelength.
- 27.** A light emitting diode (LED) package including:
an LED including electrical contacts arranged on a surface thereof; and
an electrically insulating sub-mount having: (i) a frontside including printed circuitry contacting the LED electrical contacts, (ii) a backside including electrical contact pads, and (iii) electrically conductive paths passing through the insulating sub-mount and connecting the printed circuitry of the front-side with the electrical contact pads of the back-side to deliver electrical power from to the back-side sub-mount contact pads to the LED.
- 28.** The LED package as set forth in claim 27, wherein the electrically conductive paths include:
a plurality of p-contact conductive paths arranged electrically in parallel to connect a p-type electrical contact of the LED with a positive contact pad of the backside of the sub-mount, the plurality of p-contact conductive paths being spatially distributed to promote generally uniform heat sinking; and
a plurality of n-contact conductive paths arranged electrically in parallel to connect an n-type electrical contact of the LED with a negative contact pad of the backside of the sub-mount, the plurality of n-contact conductive paths being spatially distributed to promote generally uniform heat sinking.
- 29.** The LED package as set forth in claim 27, wherein the electrically insulating sub-mount is substantially thermally insulating, the electrically insulating sub-mount further including:
thermally conductive paths through the insulating sub-mount that conduct heat from the LED.
- 30.** The LED package as set forth in claim 27, wherein the LED includes:
a light-transmissive substrate;
semiconducting layers deposited on a front-side of the substrate, the semiconducting layers defining an active region, the electrical contacts arranged on the semiconducting layers as front-side contacts such that the LED is flip-chip mounted onto the front-side of the sub-mount to contact the printed circuitry;
wherein light produced in the active region responsive to electrical input to the front-side contacts passes through the substrate and emits at least from a back-side of the substrate.
- 31.** The LED package as set forth in claim 30, wherein the semiconducting layers include layers selected from a group consisting of: gallium nitride (GaN), aluminum nitride (AlN), indium nitride (InN), and alloys thereof.
- 32.** The LED package as set forth in claim 30, wherein the backside of the substrate is patterned to define a light-refractive surface.
- 33.** The LED package as set forth in claim 27, further including:
a molded material encompassing at least the LED and providing at least one of index-matching and lensing to modify light emission from the LED.
- 34.** The LED package as set forth in claim 27, further including:
an underfill material arranged about an interface between the LED and the sub-mount.
- 35.** The LED package as set forth in claim 27, wherein the sub-mount is formed from one of a ceramic material and a composite material.
- 36.** The LED package as set forth in claim 27, wherein the electrically conductive paths of the sub-mount include metal that fills openings passing through the sub-mount.
- 37.** The LED package as set forth in claim 27, further including:
a generally annular ring disposed on the frontside of the sub-mount, the generally annular ring defining a reflective cavity inside of which the LED is disposed.
- 38.** The LED package as set forth in claim 27, wherein the LED includes a plurality of LEDs each contacting corresponding printed circuitry on the front-side of the sub-mount.
- 39-44.** (Canceled)
- 45.** The LED package as set forth in claim 27, wherein the electrically conductive paths are arranged outside of a perimeter of the LED.
- 46.** The LED package as set forth in claim 27, further including:
thermosonic bonds connecting the contacts of the LED with the printed circuitry of the submount, the thermosonic bonds including bonding bumps disposed on one of the LED and the frontside of the submount, the bonding bumps being less than about 25 microns in height.
- 47.** A light emitting diode (LED) package including:
an LED having electrical contacts; and
a submount having front and back principal sides, electrical contacts of the LED being bonded to the front principal side of the submount, the submount further including a plurality of electrically conductive paths: (i) extending between the front and back principal sides of the submount, (ii) being located outside of a perimeter of the LED, and (iii) electrically connecting with the electrical contacts of the LED.
- 48.** The LED package as set forth in claim 47, wherein the electrically conductive paths wrap around the outer surface of the submount.
- 49.** The LED package as set forth in claim 47, further including:
thermosonic bonds between the electrodes of the LED and the front principal side of the submount, the thermosonic bonds including bonding bumps disposed on one of the LED and the front principal side of the submount, the bonding bumps having heights of less than about 25 microns.