



US 20040182086A1

(19) **United States**

(12) **Patent Application Publication**
Chiang et al.

(10) **Pub. No.: US 2004/0182086 A1**

(43) **Pub. Date: Sep. 23, 2004**

(54) **MAGNETOCALORIC REFRIGERATION DEVICE**

(52) **U.S. Cl. 62/3.1**

(76) **Inventors: Hsu-Cheng Chiang, Hsinchu Hsien (TW); Bing-Chwen Yang, Hsinchu Hsien (TW); Yie-Zu Robert Hu, Hsinchu Hsien (TW)**

(57) **ABSTRACT**

Correspondence Address:
RABIN & BERDO, P.C.
Suite 500
1101 14th Street, N.W.
Washington, DC 20005 (US)

A magnetocaloric refrigeration device, placed in a controllable magnetic field, includes a heat release/absorption module. The heat release/absorption module includes a magnetocaloric working unit and at least one heat pipe. The magnetocaloric working unit is made of a magnetocaloric material. The temperature of the unit changes as the magnetic field is applied or removed. The heat pipe includes evaporation and condensation portions respectively extending from top and bottom of the magnetocaloric working unit. When a magnetic field is applied to the magnetocaloric working unit to absorb heat, the lower condensation portion of the heat pipe transfers heat upward to the magnetocaloric working unit. When the magnetic field is removed from the magnetocaloric working unit to release heat, the heat from the magnetocaloric working unit is transferred to the outside through the upper heat release portion. The magnetocaloric refrigeration device has advantages of simple structure, low production cost, and small size.

(21) **Appl. No.: 10/694,769**

(22) **Filed: Oct. 29, 2003**

(30) **Foreign Application Priority Data**

Mar. 20, 2003 (TW)..... 092204351

Publication Classification

(51) **Int. Cl.⁷ F25B 21/00**

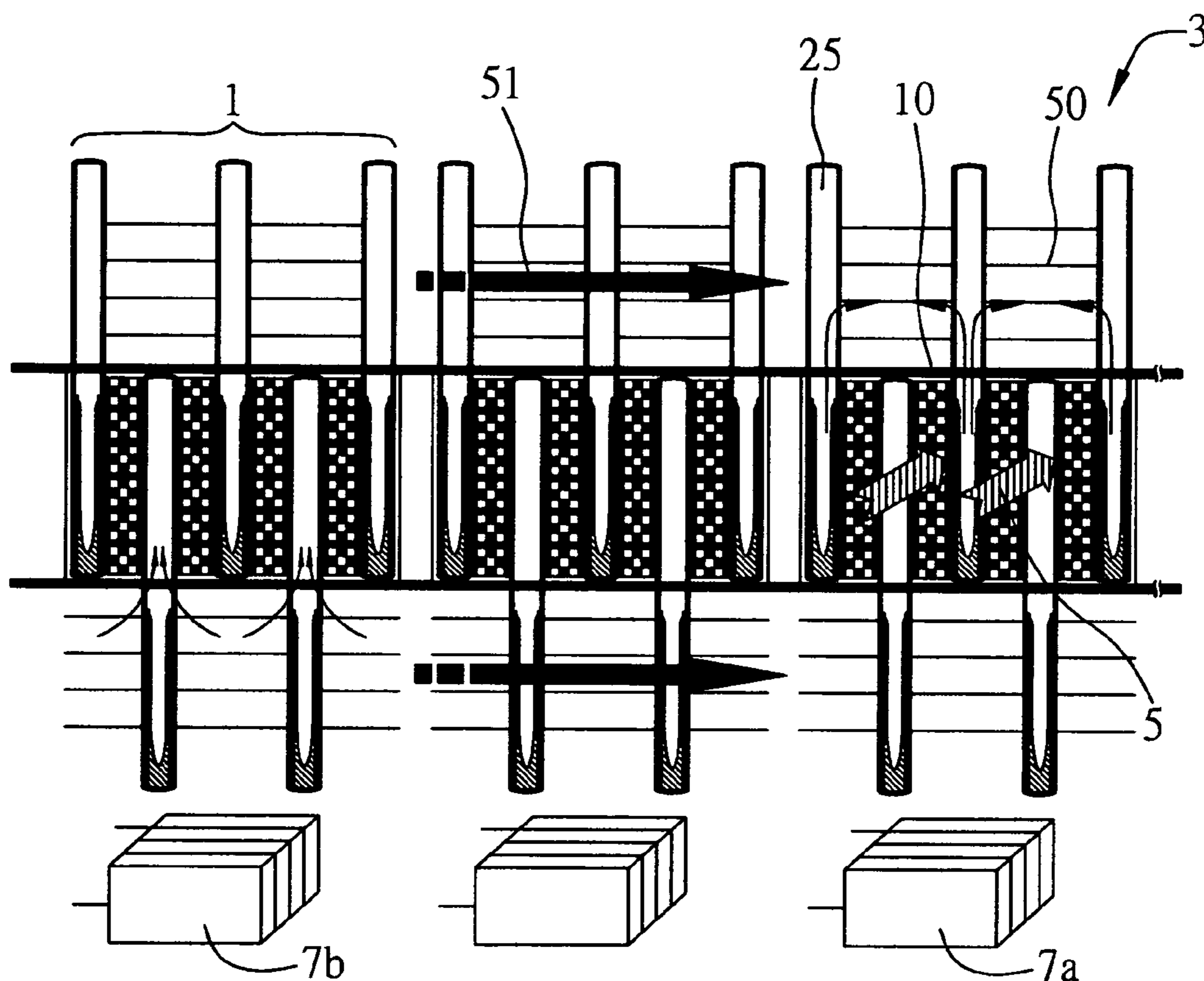

FIG. 1

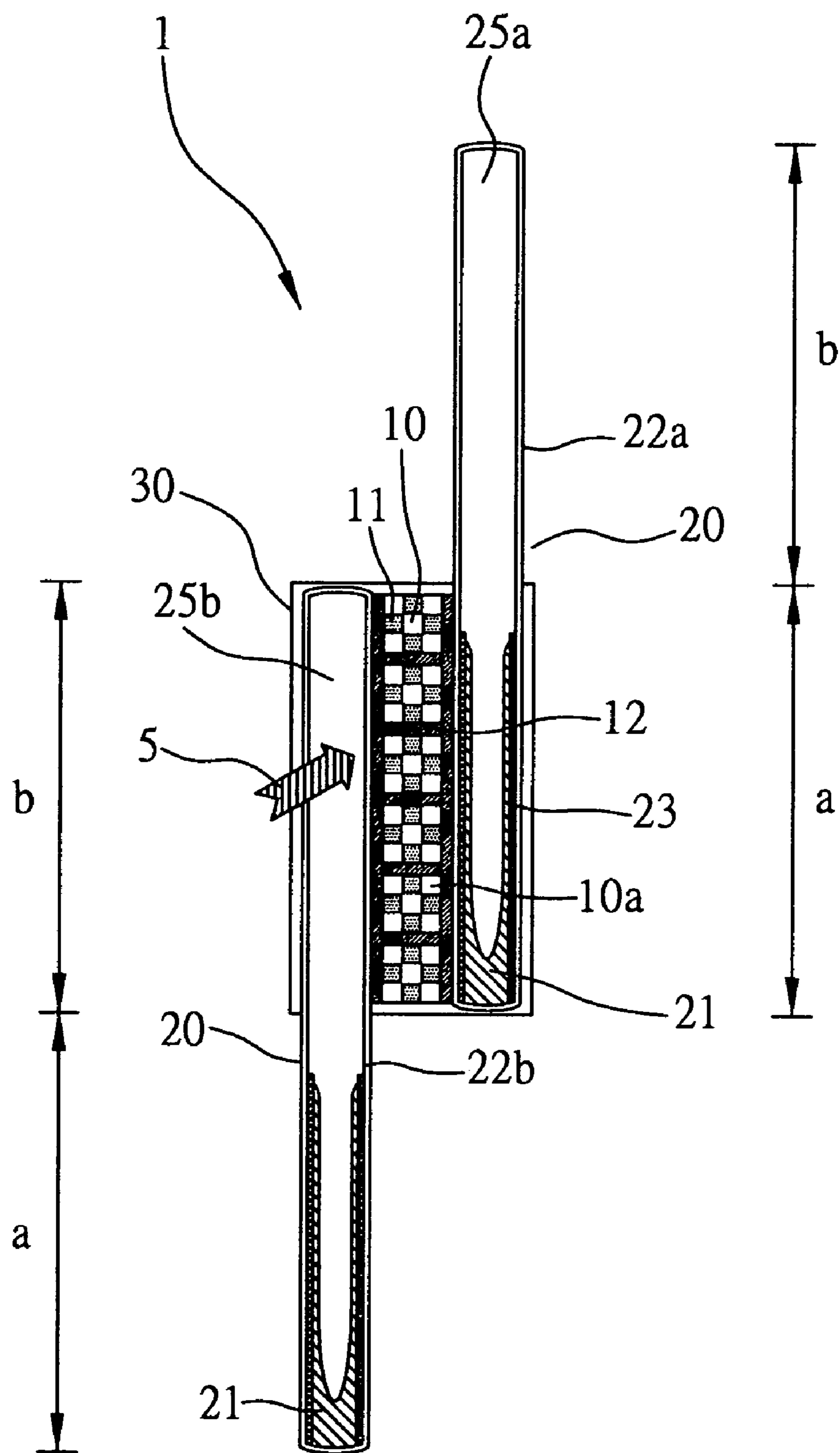

FIG. 2

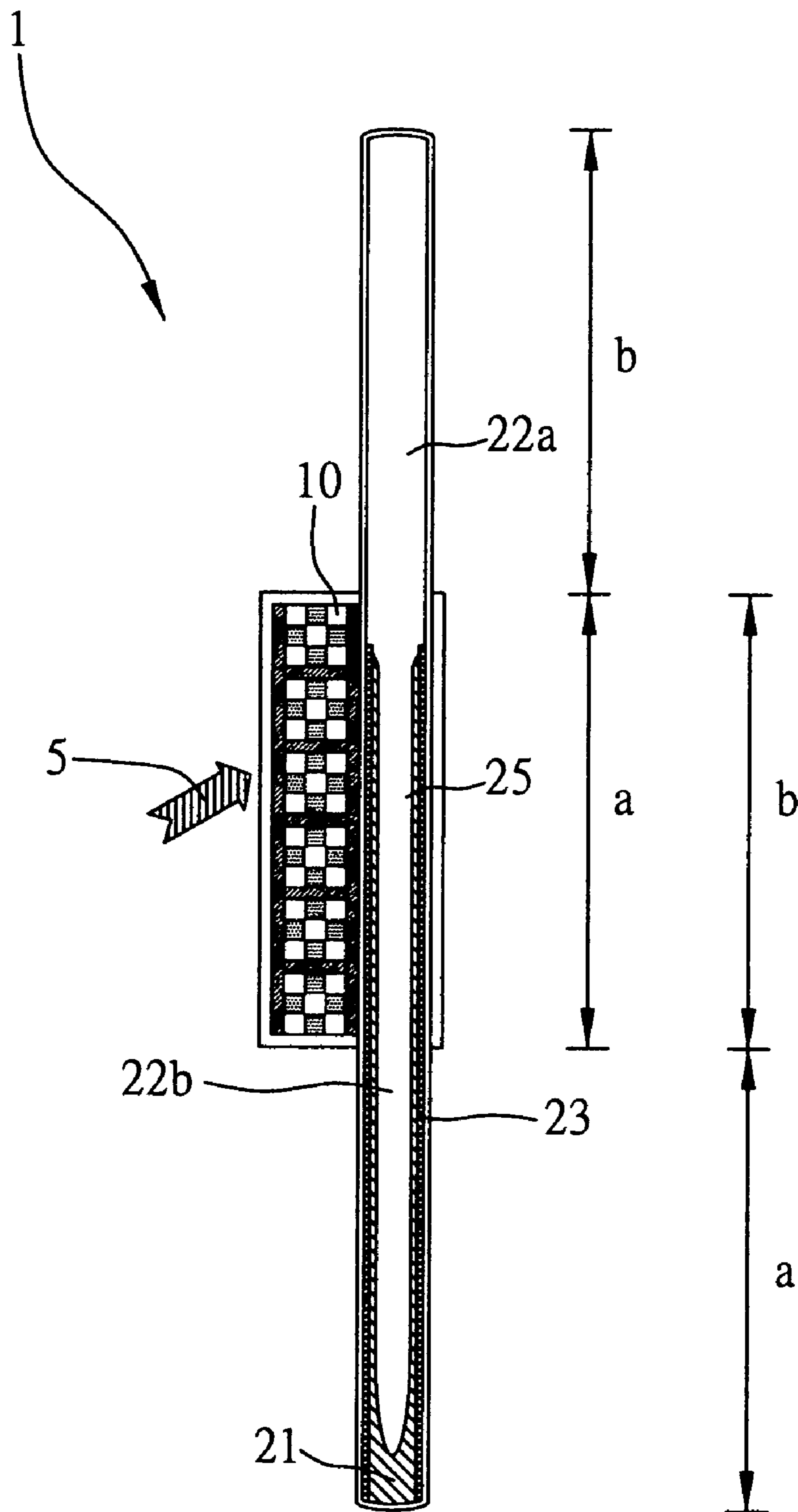

FIG. 3A

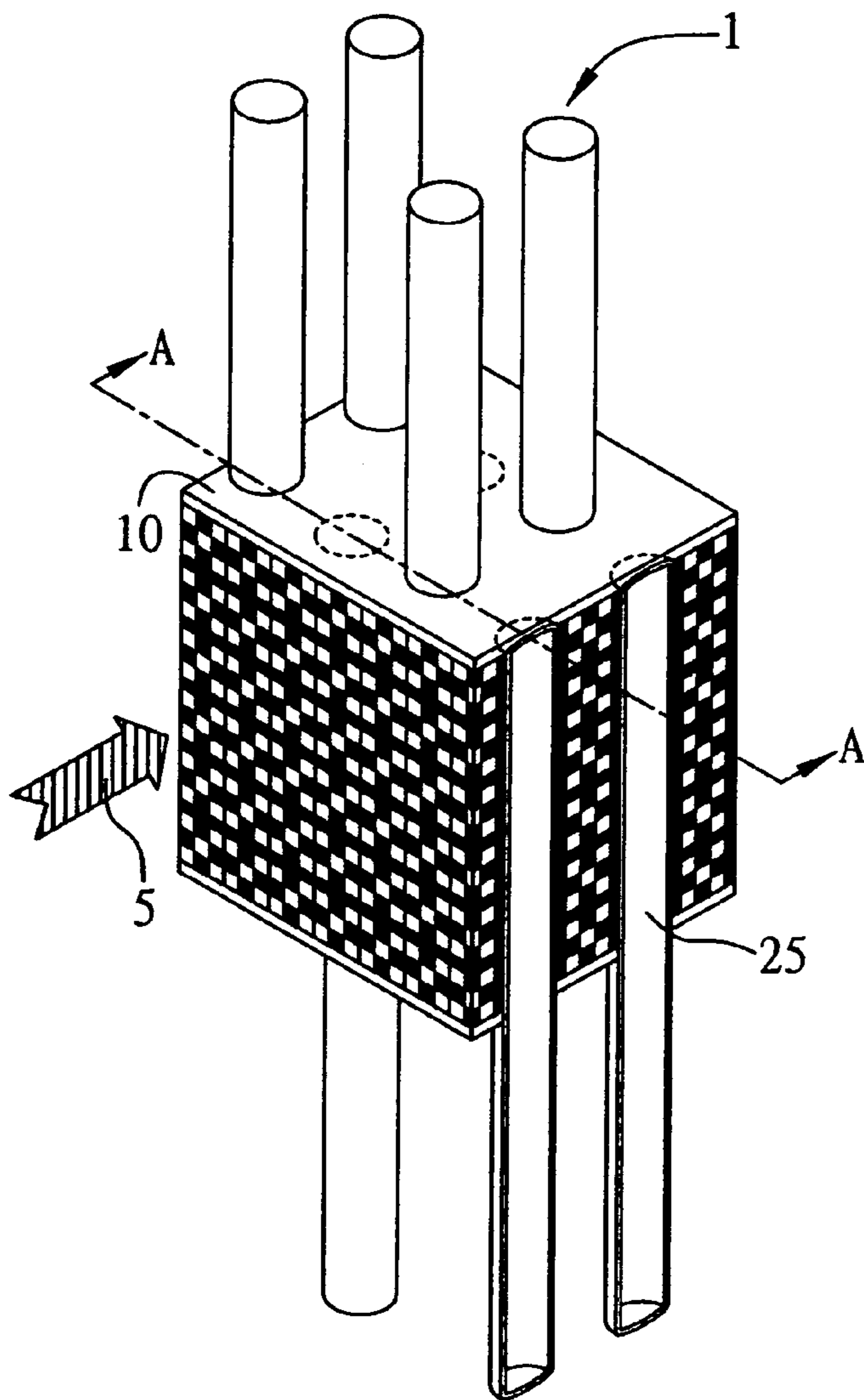

FIG. 3B

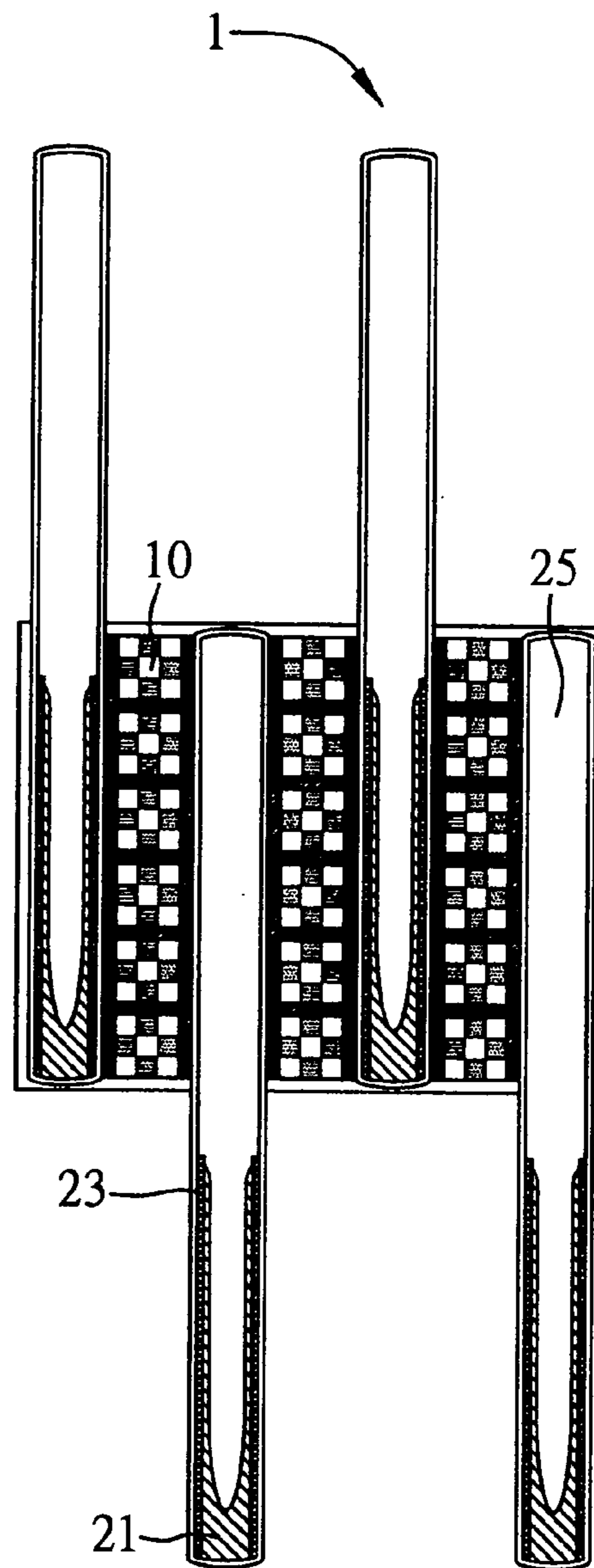

FIG. 4A

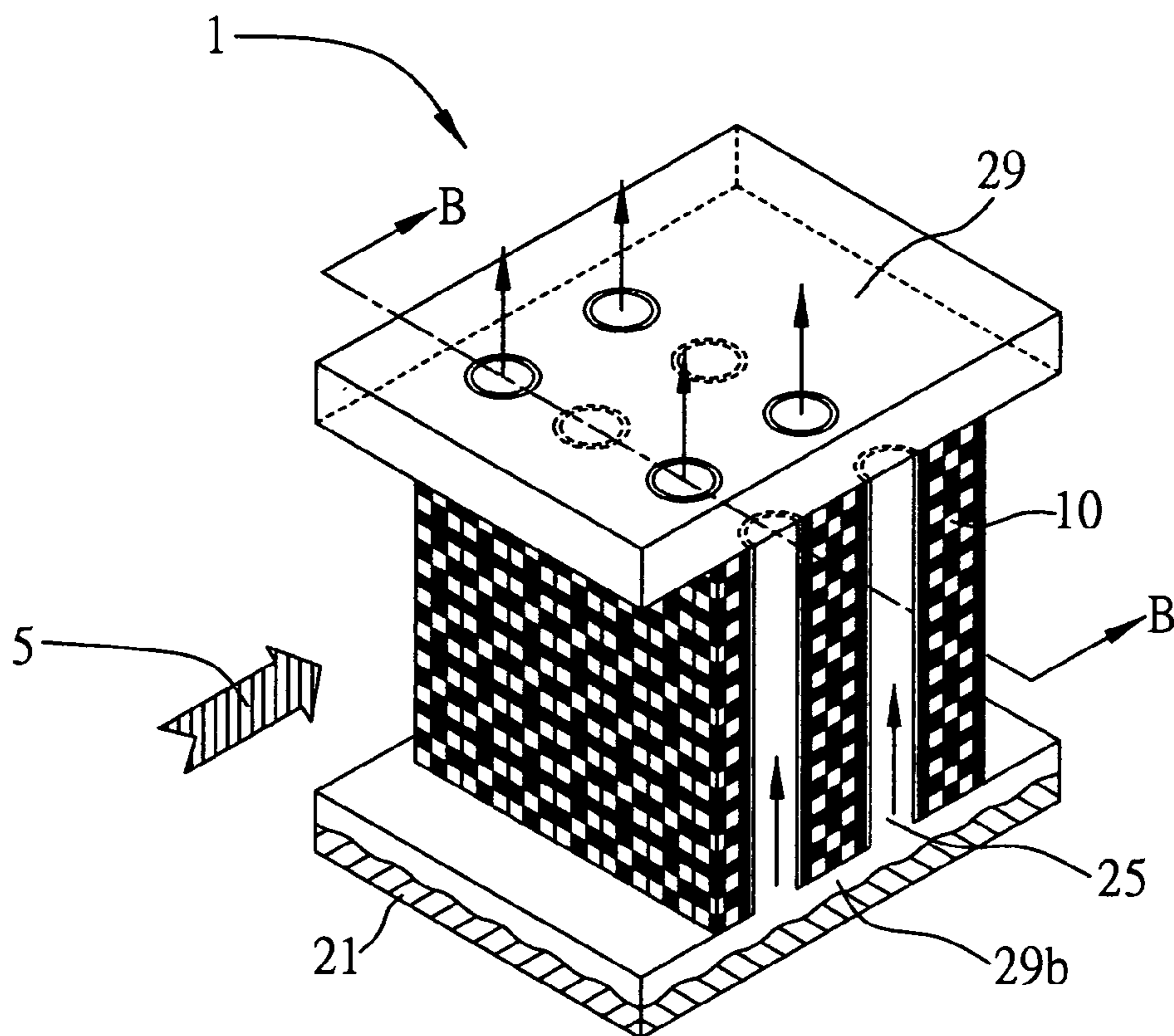

FIG. 4B

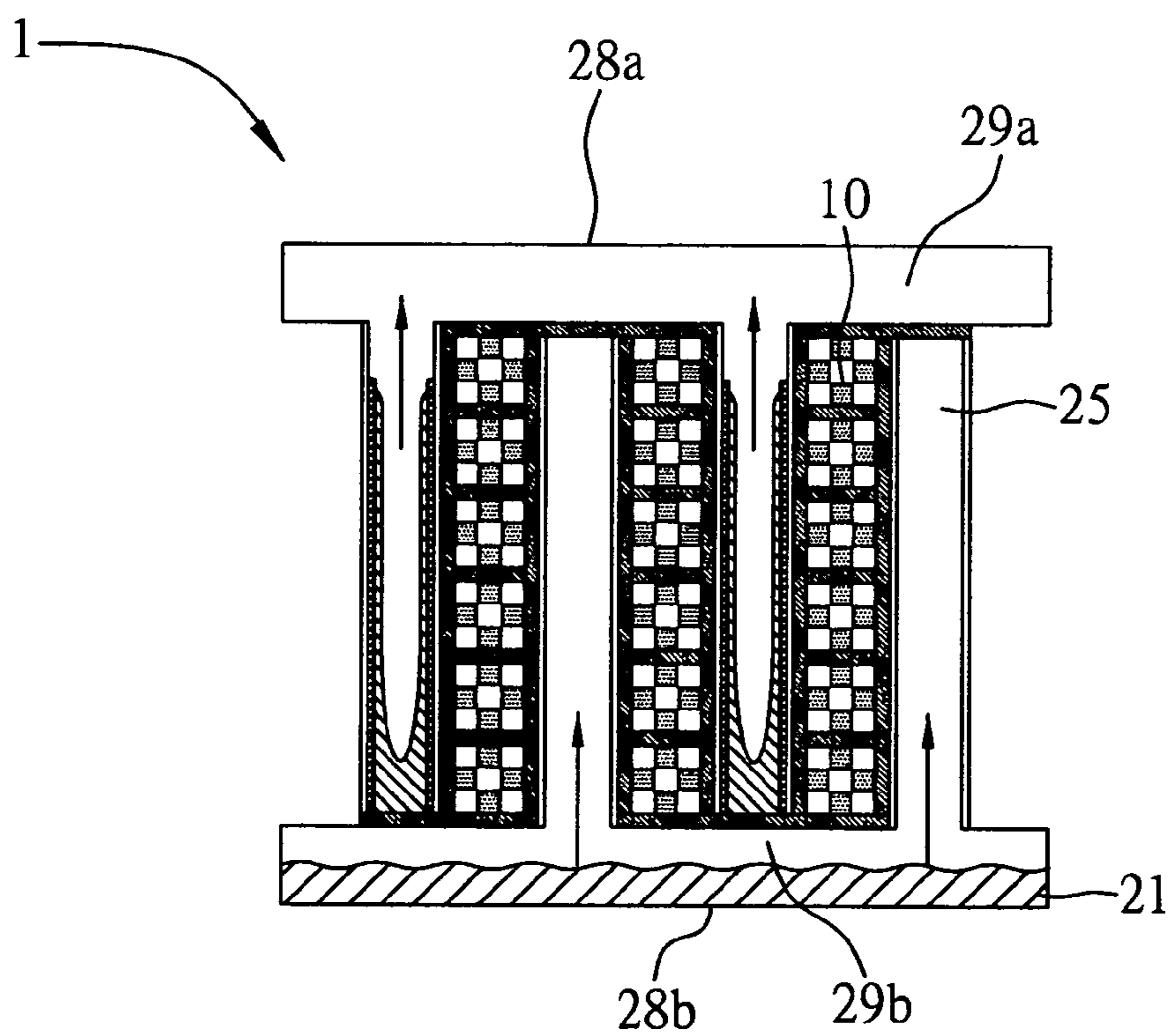

FIG. 5

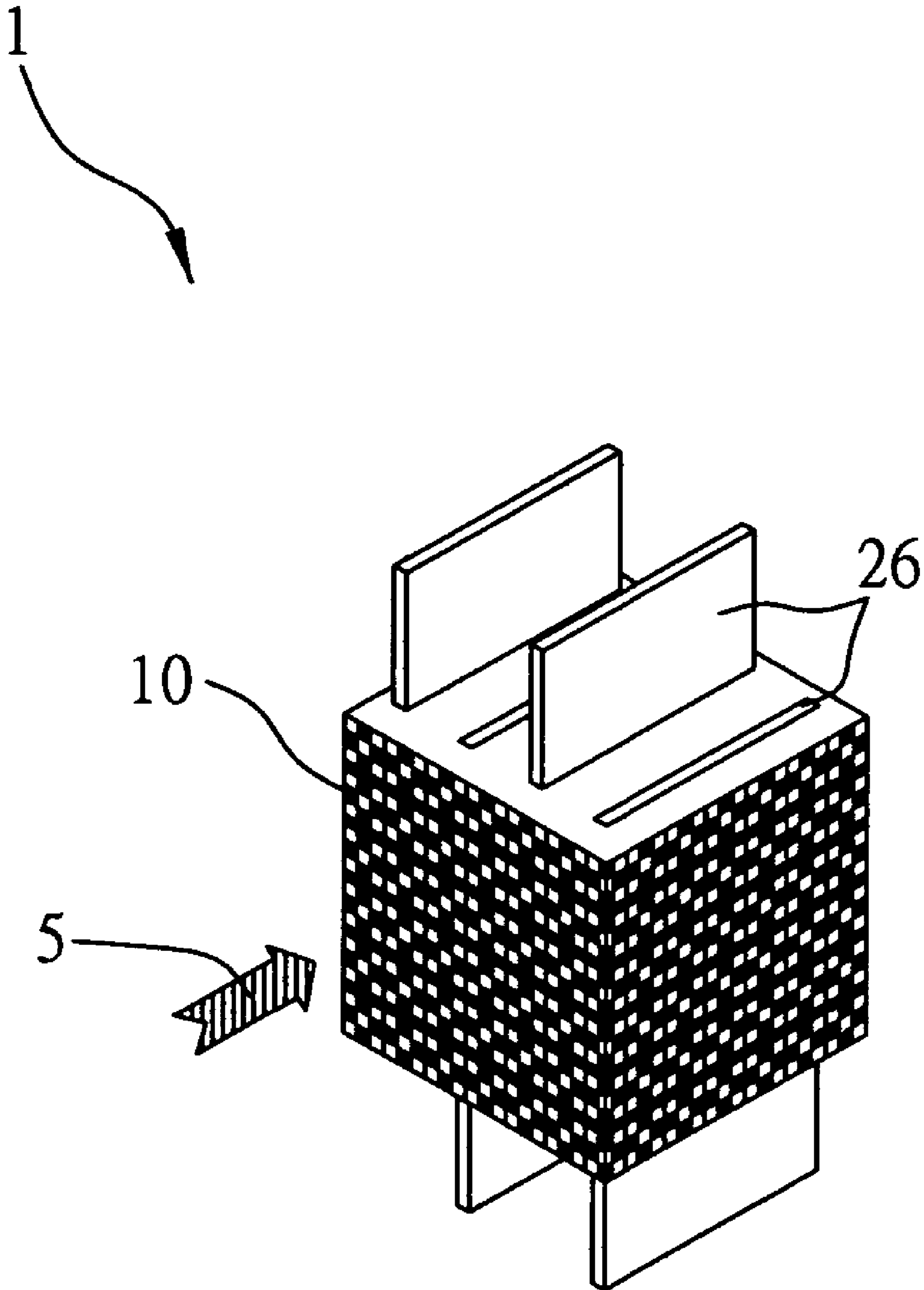

FIG. 6

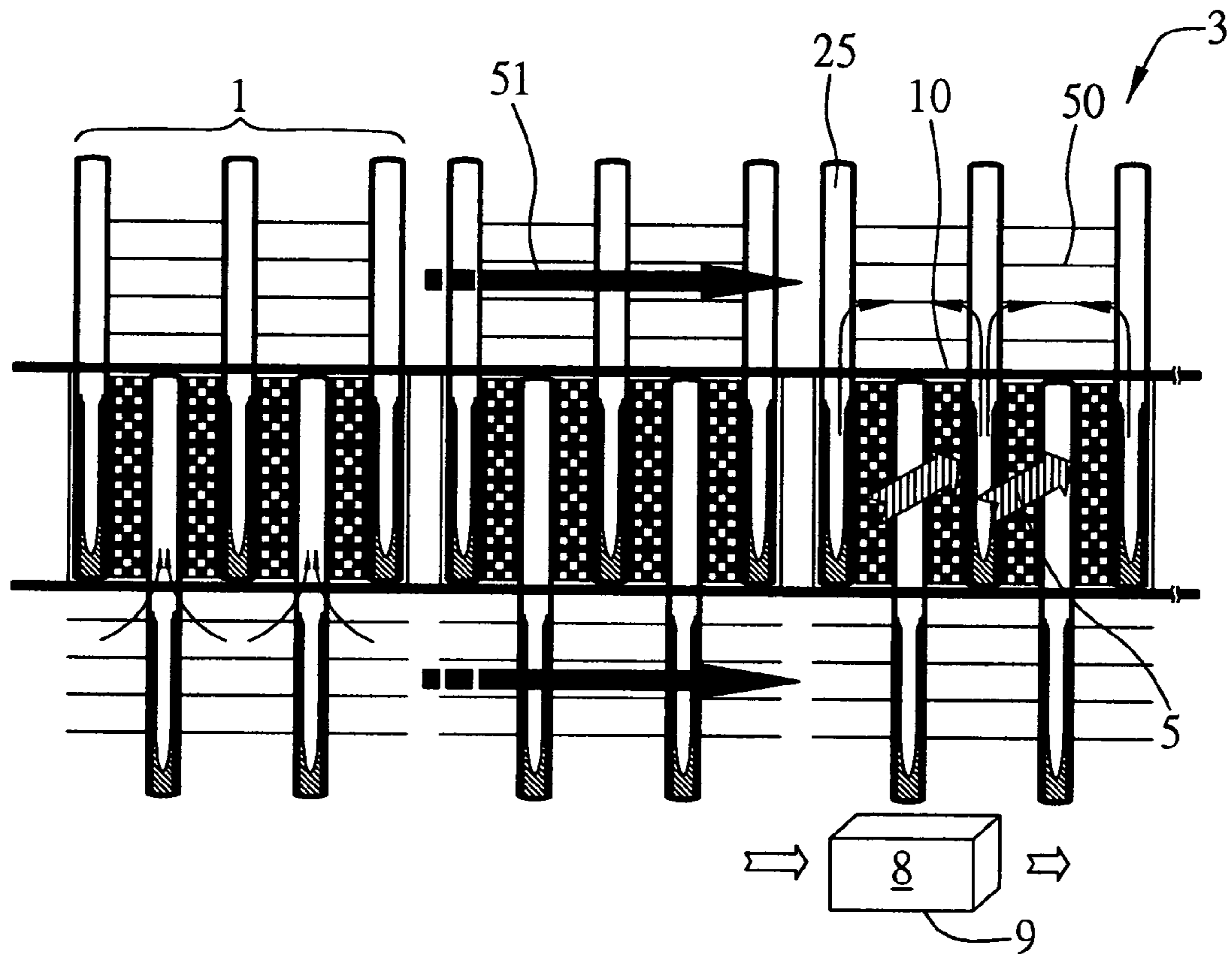

FIG. 7

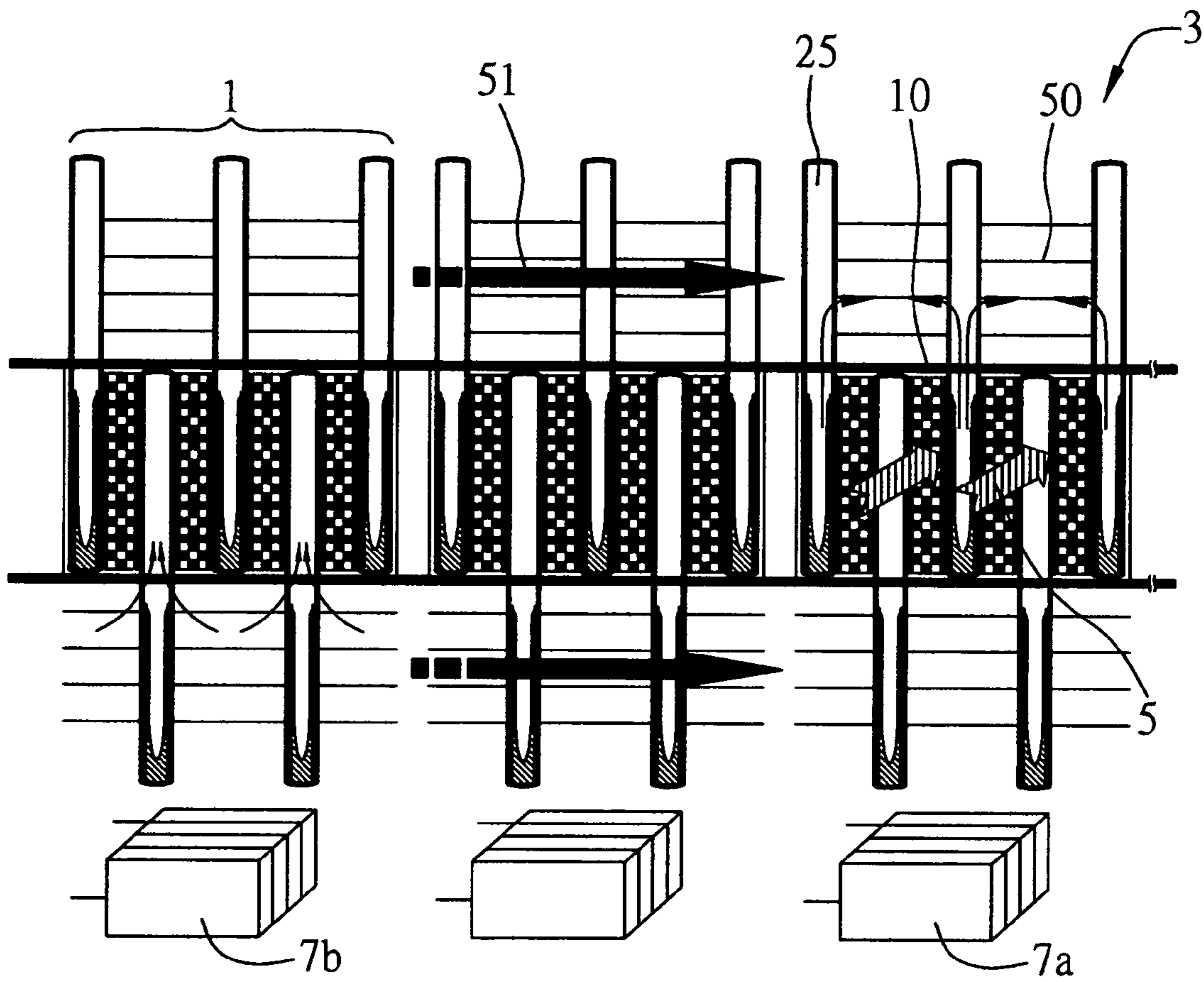

FIG. 8

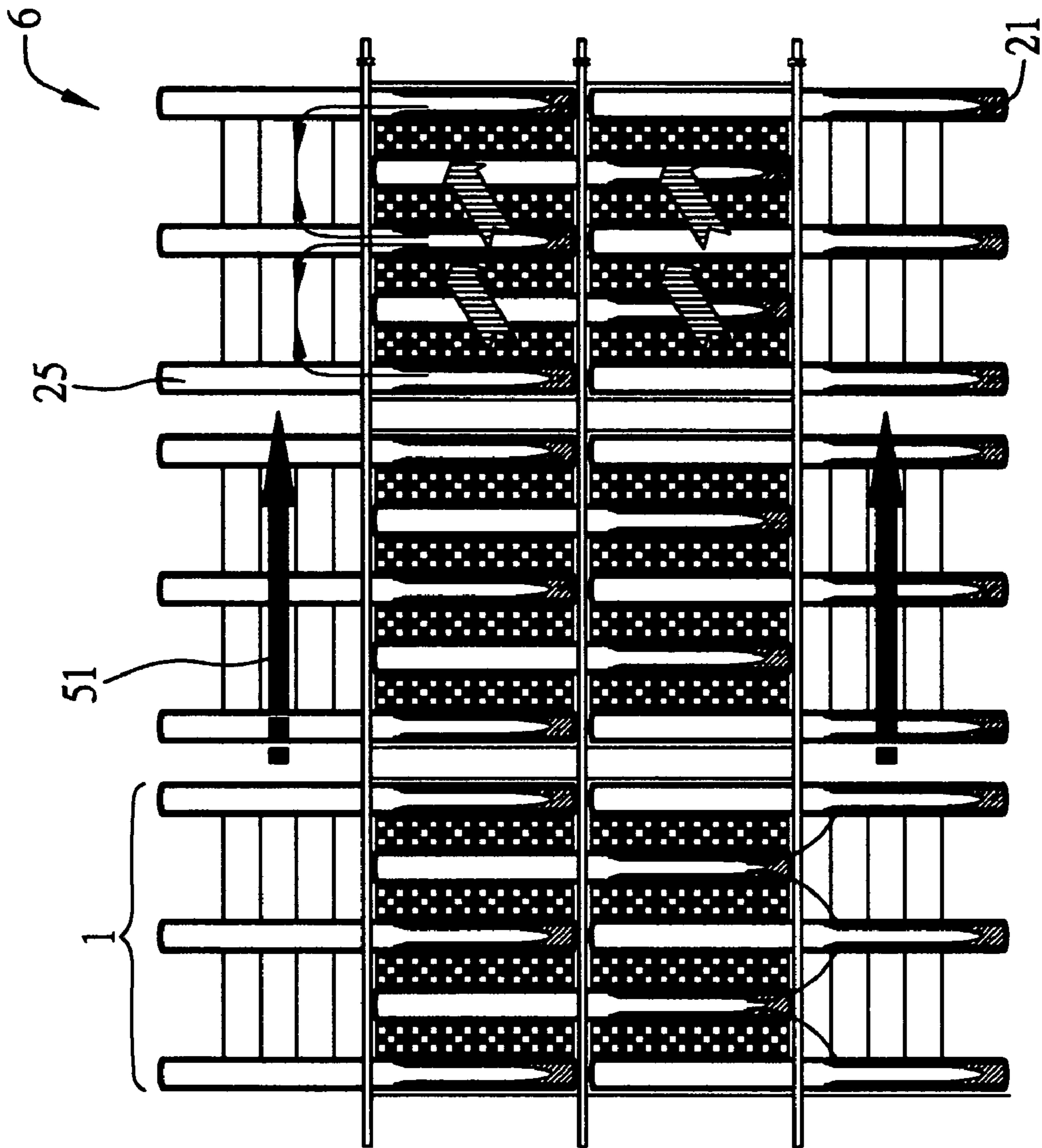

FIG. 9 (PRIOR ART)

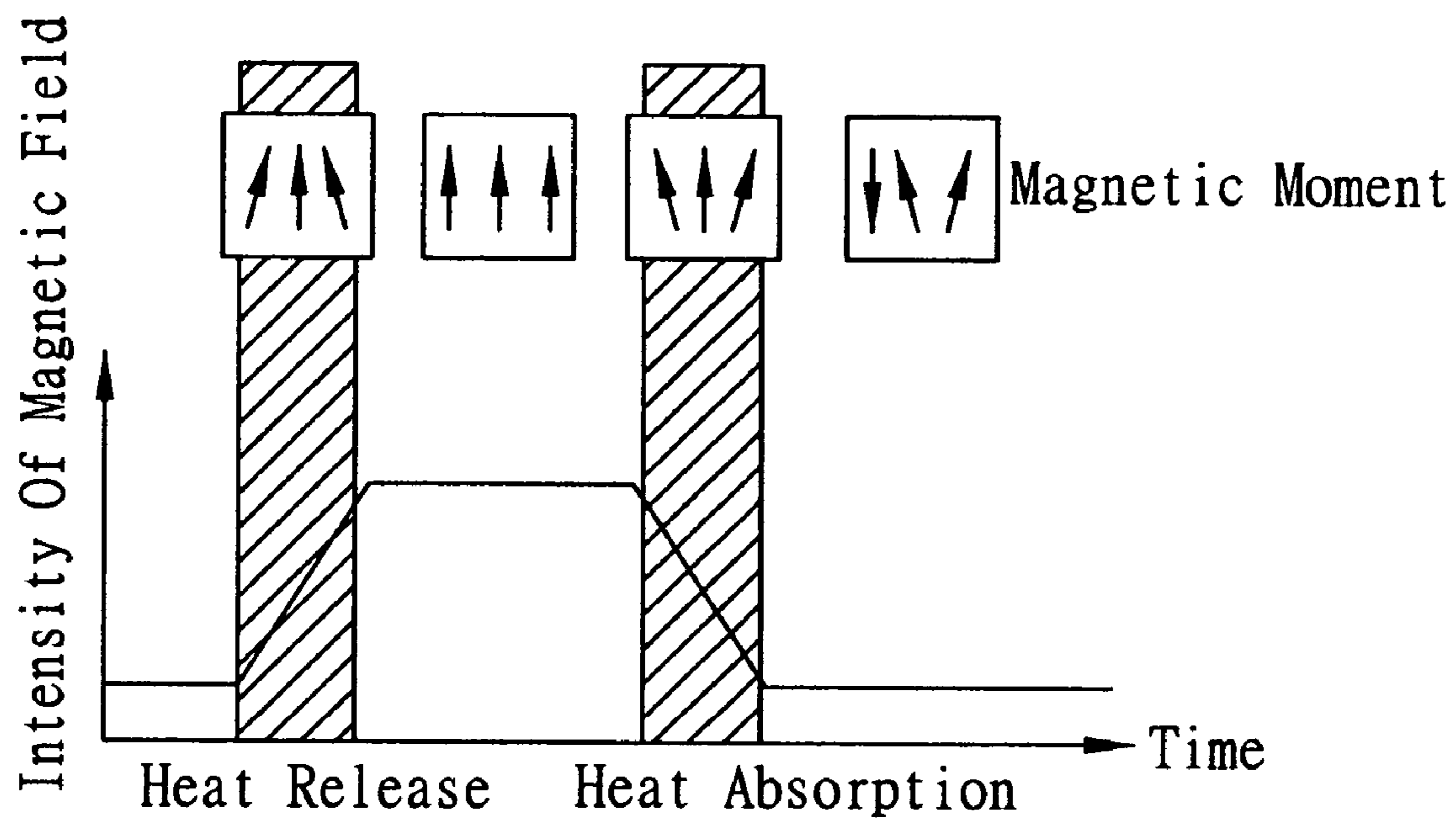

FIG. 10 (PRIOR ART)

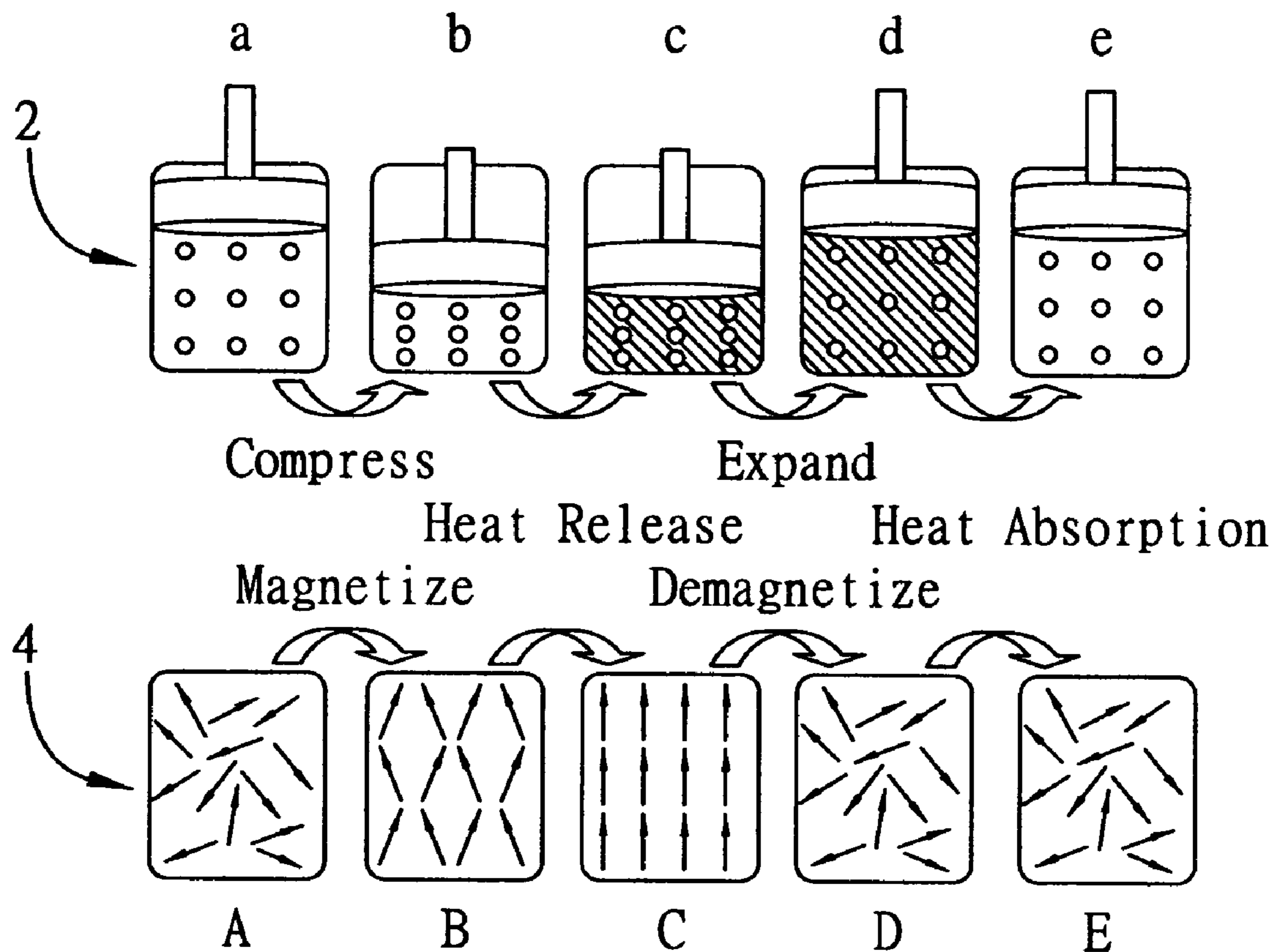

FIG. 11 (PRIOR ART)

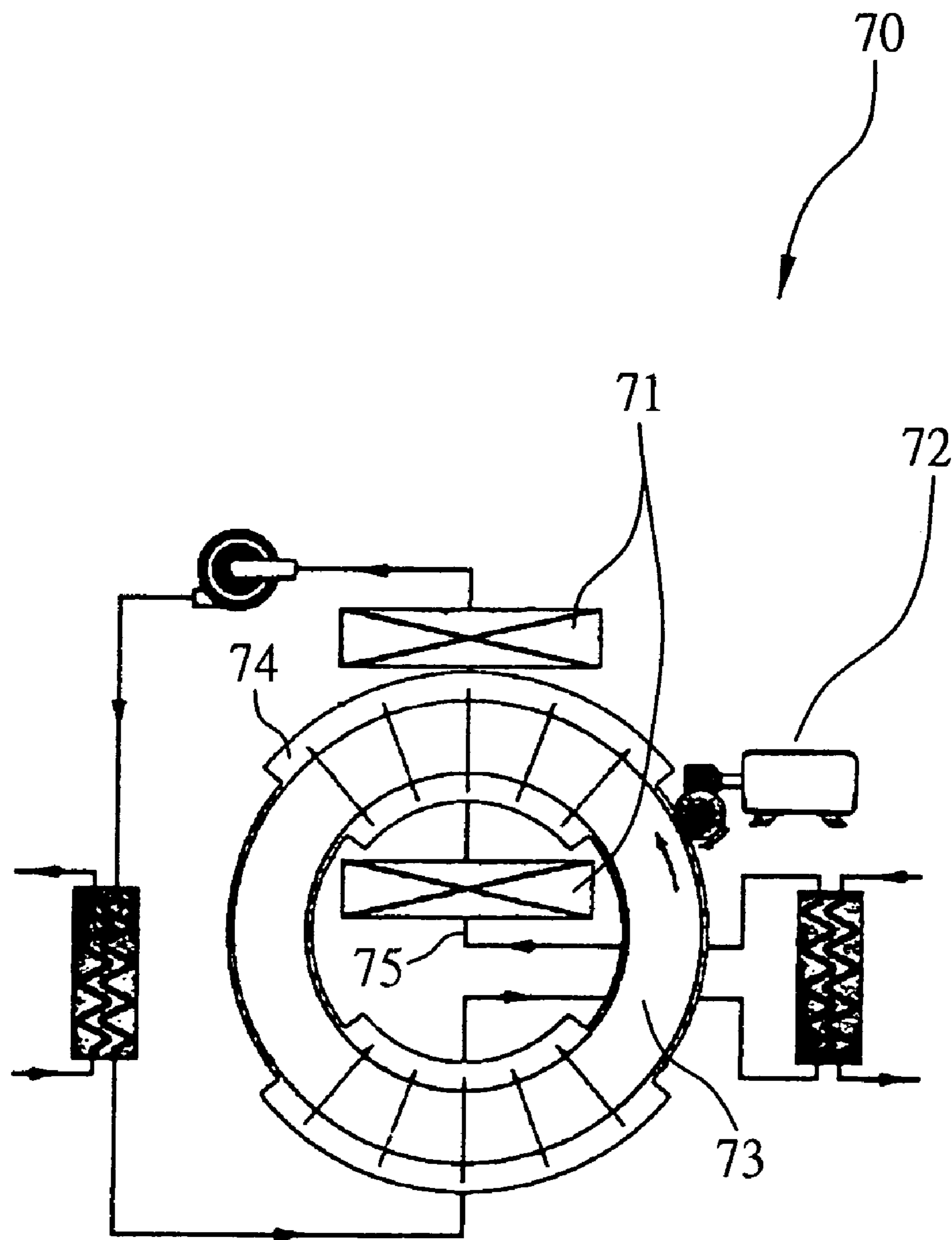
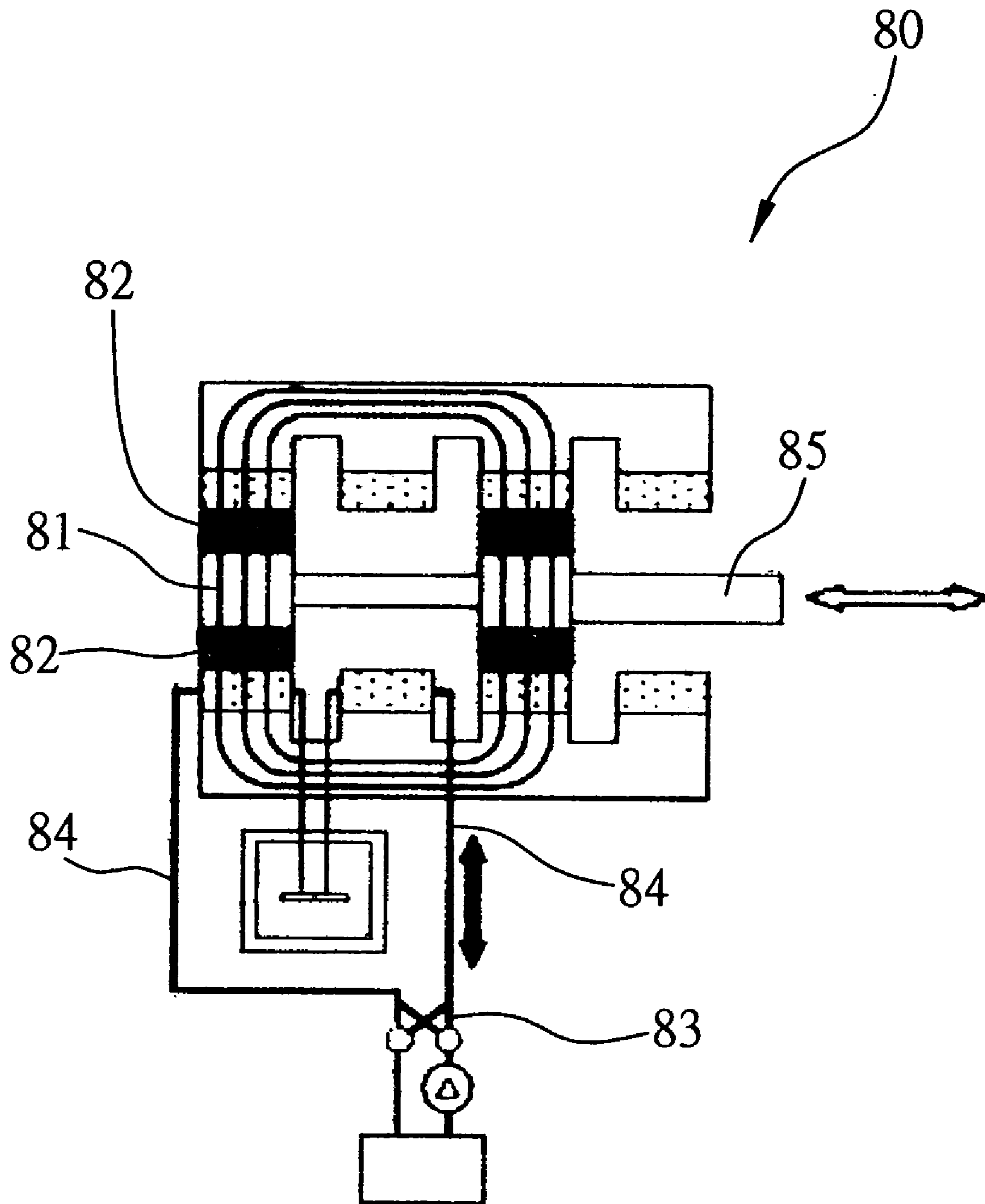

FIG. 12 (PRIOR ART)



MAGNETOCALORIC REFRIGERATION DEVICE

FIELD OF THE INVENTION

[0001] The invention relates to a magnetocaloric device, and more particularly, to a magnetocaloric device having a simplified structure, high performance, and economical manufacturing.

BACKGROUND OF THE INVENTION

[0002] A magnetocaloric effect (MCE) is caused from the magnetization/demagnetization of a ferromagnetic material such as a transition metal or a Lanthanide-series rare earth element. Specifically, electrons inside the material self-spin when subjected to an external magnetic field and are arranged in a regular way, which causes the reduction of a magnetic entropy of the material, resulting in an exothermal phenomenon due to the reduced randomness of the magnetic dipole arrangements. At this time, the temperature of the material increases. Similarly, when the magnetic field is removed, the magnetic dipoles in the ferromagnetic material are irregularly arranged, which increases the randomness of the dipole arrangements, absorbing thermal energy. At this time, the temperature of the material drops. FIG. 9 illustrates the process of the heat release and absorption known in the art.

[0003] To reduce the greenhouse effect caused by the discharge of a cooling medium (such as CFC used in most refrigerators) into the environment, and to eliminate noise generated by the compressor used in conventional cooling equipment, the magnetocaloric effect is usually implemented to replace the traditional gas-cycle in the conventional gas-compression type refrigerator. FIG. 10 is a schematic view that compares the conventional gas cycle 2 with the magnetocaloric cycle 4, illustrating the relationships respectively between pressure and the magnetic field, and the gas volume and the magnetization. In the gas cycle 2, the distribution of gas molecules is changed due to gas compression and expansion, which reduces the entropy of the gas. Specifically, the gas compression of step a) through step b) results in an exothermic effect and an increase in temperature. The gas expansion of step c) through step d) results in an endothermic effect and a decrease in temperature. In the magnetocaloric cycle 4 including two isothermal and isomagnetic field stages, an external magnetic field is applied to change the spin orientation of electrons inside the magnetic material and, thereby, reduce its entropy. At step A) through step B), when a magnetic field is applied to orderly arrange the dipoles inside the material, the temperature of the material increases, similar to the gas cycle stage where the gas is compressed. Conversely, at step C) through step D) where the magnetic field has been removed, the dipoles inside the material are irregularly arranged and thereby the temperature of the material drops, which draws ambient heat into the material. Although the two techniques have similarities, the reversibility of the dipole arrangements in the magnetocaloric cycle 4 is much greater than the reversibility of present levels in the gas cycle 2. The change in the dipole arrangement within the magnetocaloric cycle 4 is achieved through applying and removing the magnetic field. This superior characteristic of the magnetocaloric material allows a higher energy efficiency for the magnetocaloric cycle compared to gas cycle used in the conventional compression type refrigeration. An intensity of only a little

more than 5 Tesla (for a normal superconductive magnet) is required to achieve more than 50-60% of an ideal Carnot cycle. Furthermore, the temperature change in the magnetocaloric material is more uniform than that in the gas of the conventional compression type refrigerator.

[0004] Although refrigeration magnetocaloric has advantages such as high energy efficiency and low environmental pollution due to the lack of any cooling medium, its design and manufacture have some disadvantages. It is difficult to quickly move the magnetocaloric material in and out of the high-intensity magnetic field to dissipate the high thermal energy absorbed by the magnetocaloric material. Furthermore, the design of the heat exchange mechanism is critical to achieve the highest heat transfer efficiency in a magnetocaloric refrigerator. For example, a heat transfer fluid having a large contact area with the magnetocaloric material may be used and contained inside the refrigerator. Alternatively, a heat exchanger with a large heat dissipation area may be mounted in the refrigerator. Therefore, in order to optimize the magnetocaloric refrigerator, a magnetocaloric movement/rotation member, a magnetic field generating device, a heat transfer pipe and valve, and one or more heat exchangers have to be appropriately chosen, increasing the complexity of the construction as well as the manufacturing cost, and making it difficult to reduce the size of the device. Furthermore, the aggregation of all the constituent pieces (valves, etc.) may produce more noise and unstable operation than a conventional design, which presents serious obstacles in the development of this type of refrigerator.

[0005] The above disadvantages have been observed in practice with commercially available magnetocaloric refrigerators. Referring to FIG. 11, a rotary magnetocaloric refrigerator 70 is provided with a superconductive magnet 71. A rotation disk 73 made of the magnetocaloric material is controlled via a motor 72. Two fluid channels 74 are oppositely disposed along the periphery of rotation disk. As the rotation disk 73 moves in and out of the magnetic field while rotating, the increase and decrease of the temperature of the rotation disk 73 is caused by the magnetocaloric effect of the magnetocaloric material. The heat transfer fluid 75 is charged in the fluid channel 74 through a valve for heat exchange to induce refrigeration. The flow of the heat transfer fluid is controlled via appropriately setting the rotation speed of the rotation disk 73, for example, 10 rpm. However, the assembly of these constituting pieces and valves is complex and uneconomical. Furthermore, mechanical wear and operation noises are unavoidable problems.

[0006] In FIG. 12, a movable magnetocaloric refrigerator 80, manufactured by the TOSHIBA company, Japan, also exhibits the above problems. In this design, a linearly transverse reciprocating device 85 made of a movable permanent magnet 81 is located adjacent to a magnetocaloric working unit 82. As the linearly transverse reciprocating device 85 moves, the temperature in the magnetocaloric working unit 82 increases. Then, a heat transfer medium 84 is charged in under the precise control of a valve 83 for heat exchange. However, the conveyance of the heat transfer medium 84 and the operation of the valve 83 may result in energy loss, increasing the load. The linearly transverse reciprocating device 85 and the valve 83 not only tend to create the same drawbacks of the rotary magnetocaloric

refrigerator **70**, but they also reduce heat transfer efficiency and stability of the refrigeration system.

[0007] Therefore, there is a need to provide a magnetocaloric refrigeration device that overcomes the problems of the prior art, has a simplified and smaller structure, and is more economical to manufacture.

SUMMARY OF THE INVENTION

[0008] It is a primary object of the invention to provide a magnetocaloric refrigeration device that has high heat transfer efficiency.

[0009] It is another object of the invention to provide a magnetocaloric refrigeration device that has a simple structure.

[0010] It is another object of the invention to provide a magnetocaloric refrigeration device that is economical to manufacture.

[0011] It is another object of the invention to provide a magnetocaloric refrigeration device that can be used in a compact system.

[0012] Finally, it is another object of the invention to provide a magnetocaloric refrigeration device that can be used in a magnetic refrigerator, does not need valves and reciprocating devices.

[0013] To achieve the above and other objectives, the magnetocaloric refrigeration device of the invention placed in a controllable magnetic field comprises a heat release/absorption module, at least one first heat pipe and at least one second heat pipe. The heat/absorption module comprises a magnetocaloric working unit made of a magnetocaloric material. The temperature of the unit changes as a magnetic field is applied or removed to release or absorb heat respectively. The first heat pipe includes a first evaporation portion and a first condensation portion. The first condensation portion is connected on the magnetocaloric working unit and the first evaporation portion extends from a bottom of the magnetocaloric working unit. The second heat pipe has a second evaporation portion and a second condensation portion. The second evaporation portion is connected on the magnetocaloric working unit, and the second condensation portion extends from a top of the magnetocaloric working unit. When the controllable magnetic field is removed to allow heat absorption of the magnetocaloric working unit, the heat is subsequently transferred upward to the magnetocaloric working unit through the first evaporation portion and the first condensation portion via flow of a working medium through the first heat pipe. When the controllable magnetic field is applied on the magnetocaloric working unit to release heat, the heat is transferred to the second evaporation portion of the second heat pipe, and further to the outside through the second condensation portion via flowing of the working medium. Thereby, a magnetocaloric refrigeration system is accomplished.

[0014] The magnetocaloric material is composed of Gd, Si, and Ge in a relation of $Gd_5(Si_xGe_{1-x})_4$. The magnetocaloric material may be packed in a powder form in the magnetocaloric working unit. Alternatively, the magnetocaloric material may be deposited to form an alloy film for production of the magnetocaloric working unit.

[0015] The heat pipes are mounted on the magnetocaloric working unit. Heat absorption/release is achieved through the magnetization/demagnetization of the magnetocaloric material, using highly efficient heat-transfer pipes as a heat transfer mechanism. The flow of the working medium carries away heat to be dissipated. This system eliminates the need for highly polluting cooling mediums, such as those used in conventional gas-cycle compressors, and further reduces mechanical vibration, wear, and operating noise.

[0016] Furthermore, a plurality of magnetocaloric refrigeration devices can be ganged together to make a refrigeration system, in which a heat-exchanging medium flows through the heat release/absorption extensions of each heat pipe. The magnetocaloric refrigeration device can be used to construct a magnetic refrigerator without the need of any of the gears or valves that are necessary for a conventional refrigerator. Therefore, the operation stability and refrigeration effect of the whole system are improved.

[0017] To provide a further understanding of the invention, the following detailed description illustrates embodiments and examples of the invention, this detailed description being provided only for illustration of the invention.

BRIEF DESCRIPTION OF THE DRAWINGS

[0018] The drawings included herein provide a further understanding of the invention. A brief introduction of the drawings is as follows:

[0019] **FIG. 1** is a side view of a magnetocaloric refrigeration device according to a first embodiment of the invention;

[0020] **FIG. 2** is a side view of a magnetocaloric refrigeration device according to a second embodiment of the invention;

[0021] **FIG. 3A** and **FIG. 3B** are schematic views of a magnetocaloric refrigeration device according to a third embodiment of the invention;

[0022] **FIG. 4A** and **FIG. 4B** are schematic views of a magnetocaloric refrigeration device according to a fourth embodiment of the invention;

[0023] **FIG. 5** is a schematic view of a magnetocaloric refrigeration device according to a fifth embodiment of the invention;

[0024] **FIG. 6** is a schematic view of a magnetic refrigerator assembled with a magnetocaloric refrigeration device having a permanent magnet according to one embodiment of the invention;

[0025] **FIG. 7** is a schematic view of a magnetic refrigerator assembled with a magnetocaloric refrigeration device having an electromagnet according to one embodiment of the invention;

[0026] **FIG. 8** is a schematic view of a magnetic refrigerator assembled with a multi-layered magnetocaloric refrigeration device according to one embodiment of the invention;

[0027] **FIG. 9** (PRIOR ART) is a schematic view illustrating the process of heat release and absorption used by an embodiment of the invention;

[0028] FIG. 10 (PRIOR ART) is a schematic view that compares the conventional gas cycle with the magnetocaloric cycle;

[0029] FIG. 11 (PRIOR ART) is a schematic view of a conventional rotary magnetic refrigerator; and

[0030] FIG. 12 (PRIOR ART) is a schematic view of a conventional magnetic refrigerator having a movable magnet.

DETAILED DESCRIPTION OF THE EMBODIMENTS

[0031] Wherever possible in the following description, like reference numerals will refer to like elements and parts unless otherwise noted.

[0032] Referring to FIG. 1, a magnetocaloric refrigeration device 1 includes a magnetocaloric working unit 10 made of a material that has a magnetocaloric effect (hereafter referred to as a magnetic material). One-way heat transfer elements 20 are mounted on two opposite surfaces of the magnetocaloric working unit 10. One of the heat transfer elements 20 protrudes from a top of the magnetocaloric working unit 10, while the other heat transfer element 20 oppositely protrudes from a bottom of the magnetocaloric working unit 10. A working medium 21 fills each one-way heat transfer element 20. The heat transfer elements 20 respectively provided with the working medium 21 therein are placed in a metallic container 30. Thereby, the magnetocaloric working unit 10 is subjected to a controllable periodic magnetic field 5.

[0033] The magnetocaloric working unit 10 is made of a magnetocaloric material 11, such as an alloy of Gd, Si, and Ge at a composition ratio of $Gd_5(SixGe_{1-x})_4$, wherein x is optionally selected in order to adjust the magnetocaloric intensity of the alloy 11. Different composition of the alloy 11 influence the temperature range due to the change of its interior phase. Methods for forming the magnetocaloric working unit 10 include the use of the alloy 11 packed in a powder form according to a specific shape, and a film formation by a nanometer process. The magnetocaloric working unit requires a material that has the optimal magnetocaloric effect among the magnetocaloric materials known in the art. However, the magnetocaloric material suitable for the invention is not limited to any specific material. Other compounds such as GdNi, $Gd_5(Si_2)$, $Gd_3Ga_5O_{12}$, GdPd, and the like may also be adequate to form the magnetocaloric working unit 10.

[0034] The magnetocaloric working unit 10 is placed in the controllable magnetic field 5 with a working surface 10a of the magnetocaloric working unit 10 parallel to the magnetic field 5 to receive a maximal magnetic effect, i.e. highest magnetic flux (density) through the working surface 10a to obtain the highest heat transfer efficiency. Furthermore, as shown in FIG. 1, a sublevel 12 is mounted at a constant interval in the magnetocaloric working unit 10. The sublevel 12 is made of, for example, a resin.

[0035] In this embodiment of the invention, the one-way heat transfer elements 20, as shown in FIG. 1, are hollow closed heat pipes 25a, 25b. The heat is transferred upwardly to the working medium 21 in a bottom or on an inner wall of a bottom of the heat pipes 25a, 25b due to high specific heat and siphon/capillary attraction. The inner walls of the

heat pipes 25a, 25b respectively have wick structures at their lower sections, which enable one-way heat transfer preventing reverse heat transfer. At the upper sections, the inner walls are bare/featureless while the outer walls are provided with a plurality of fins (not shown) to increase the heat-transfer efficiency. According to another example, the heat pipes 25a, 25b may have bare inner walls along the whole section, or inner walls provided with a porous structure 23, which also achieves heat transfer.

[0036] The heat pipe can be made of copper, stainless steel, or tungsten, and the like. The working medium 21 can be among other things, water, silver solution, acetone, liquid nitrogen or ethanol. The working medium 21 is selected based on the heat transfer property needed by the refrigeration requirement. For example, if the working medium 21 is used at a normal temperature, then the working medium 21 can be water or ethanol. If the working medium is used at a temperature lower than the freezing point of water, then it may be liquid nitrogen. Different pipes may be packed with different mediums 21 therein or the same, as long as the working medium 21 can evaporate in the presence of heat as the magnetocaloric material magnetizes/demagnetizes.

[0037] The heat pipes 25a, 25b respectively mounted to the opposite sides of the magnetocaloric working unit 10 are located at different levels to respectively serve as a heat sink and a heat absorber. As illustrated, the heat pipe 25a is provided with an externally exposed heat release extension 22a protruding from a top of the magnetocaloric working unit 10. The heat pipe 25b is provided with an externally exposed heat absorption extension 22b protruding from a bottom of the magnetocaloric working unit 10. Thereby, the heat pipes 25a, 25b respectively dissipate heat from the magnetocaloric working unit 10 and absorb heat from an ambient environment as the magnetic field 5 is applied or removed. The exposed extensions 22a, 22b of the heat pipes 25a, 25b have a certain extension length so that for each pipe, there is a temperature difference respectively between the externally exposed extension and the pipe to increase the heat-exchange efficiency when the magnetocaloric working unit 10 operates.

[0038] The principle of operation of the magnetocaloric refrigeration device 1 is described hereafter. The magnetocaloric working unit 10 is subjected to the controllable periodic magnetic field 5. When the magnetocaloric working unit 10 moves in the magnetic field 5, the portion of each pipe that releases heat caused by the magnetocaloric effect is referred to as an evaporation portion "a". The portion of each pipe that absorbs the heat as the magnetocaloric working unit 10 moves out of the magnetic field 5 is referred to as a condensation portion "b". The control and frequency of the periodic magnetic field 5 are determined according to the device design. For example, a stationary electromagnet or superconductive magnet that alternately magnetizes and demagnetizes may be used. Alternatively, a back-and-forth movement/rotation member with a permanent magnet may be used to periodically pass through a fixed permanent magnet. In this case, the unit 10 is mounted on the back-and-forth movement/rotation member to pass through the periodic magnetic field 5. Therefore, when the magnetic field 5 magnetizes the magnetocaloric working unit 10, the entropy of the magnetocaloric material 11 changes to generate heat absorbed by the heat pipes 25a, 25b. The liquid working medium 21 in the evaporation portion "a" of the

heat pipe **25a** (either the bottom of the pipe or the wick structure **23**) evaporates producing cooling while the temperature at the upper section of the heat pipe **25b** increases. The evaporated working medium travels through the heat pipe **25a** to the condensation portion “b” of the externally exposed heat releasing extension **22a**. Optionally, receiver equipment may be externally mounted on a top of the magnetocaloric refrigeration device **1** to accelerate the conveyance of the evaporated working medium **21**. After the medium travels to the condensation portion “b” to release the heat or transmit the heat to the receiver equipment, the temperature of the working medium **21** progressively decreases until the working medium **21** condenses due to the external exposure of the condensation portion “b” away from the magnetocaloric working unit **10**. The condensed working medium **21** becomes liquid and flows back to the evaporation portion “a” along the bare inner walls of the condensation portion “b”. That is, the condensed working medium **21** flows down to the bottom of the heat pipe **25a** or adheres on the wick structure **23** at the upper section. Then, a new cycle of evaporation/condensation begins. On the other hand, the working medium **21** at the evaporation portion “a” of the bottom **22b** of the heat pipe **25b**, which downwardly protrudes from the magnetocaloric working unit **10**, does not evaporate immediately after the magnetic field **5** is applied. After the magnetic field **5** is removed and the magnetocaloric working unit **10** suddenly cools down, the working medium **21** at the evaporation portion “a” at the bottom **22b** of the heat pipe **25b** absorbs heat released from the refrigeration load and consequently evaporates. The evaporated working medium **21** travels upwardly in the heat pipe **25b**. A decrease in the temperature of the magnetocaloric working unit **10** draws the ambient heat (for example from the receiver equipment externally mounted on the bottom of the refrigeration device **1**) and the heat from the working medium **21** toward the magnetocaloric working unit **10** to achieve refrigeration. The working medium **21** condenses at the condensation portion “b” and loses its thermal energy. The condensed working medium **21** flows down along the inner wall of the heat pipe **25b** until it reaches the evaporation portion “a” at the bottom of the heat pipe **25b**. Then, another exothermal/endothermic cycle ensues, again involving evaporation/condensation of the working medium **21**. In the one-way heat transfer mechanism of the invention, the magnetocaloric working unit **10** absorbs heat from heat pipe **25b** and releases heat to the outside through heat pipe **25a**.

[0039] In this one-way heat transfer mechanism, the heat pipes **25a**, **25b** located at different levels and mounted with external extensions respectively operate as a heat release means and a heat absorption means. The working medium at the top and the bottom of the magnetocaloric refrigeration device **1** evaporates quickly and thus has high heating/refrigeration performance. The magnetocaloric refrigeration device **1** can be used in or mounted on a refrigeration system, according to the user’s requirements. For example, by flowing the working medium **21** through the top and the bottom of the magnetocaloric refrigeration device **1**, heat dissipation and cooling can be achieved at the same time. A plurality of fins are further mounted on the top and bottom of the magnetocaloric refrigeration device **1** to increase surface area for heat dissipation. Alternatively, if the working medium or a valve is not provided, the magnetocaloric refrigeration device **1** can be provided with a cooling or

heating receiver system. For example, an external cooling receiver system is connected to the bottom of the magnetocaloric refrigeration device **1** for further heat dissipation. The magnetocaloric refrigeration device **1** of the invention has a small structure, which facilitates mounting inside the heat dissipation assembly of an electronic device.

[0040] The implementation of the invention is not limited to the above embodiment. For example, the number and the locations of the one-way heat transfer units **20** are based on the design requirements. For example, the one-way heat transfer unit **20** may be mounted on a single side of the magnetocaloric working unit **10**. In a second embodiment of the invention as illustrated, the pipes **25** release and absorb heat when the magnetic field **5** respectively is applied and removed. That is, when the temperature of the magnetocaloric working unit **10** increases, the working medium **21**, adhered on the wick structure **23** and wetting a middle section of the heat pipes **25** due to siphon/capillary attraction, evaporates and thereby carries heat out of the heat pipes **25** from the tops of the heat pipes **25**. On the other hand, when the temperature of the magnetocaloric working unit **10** decreases, the working medium **21** serves as a heat absorber to carry heat from the bottoms of the heat pipes **25** to the magnetocaloric working unit **10**. The heat pipes **25**, as illustrated, protrude from the top and bottom of the magnetocaloric working unit **10** to provide improved heat release and absorption performance. The externally exposed heat release extension **22a** at the top of the magnetocaloric working unit **10** serves as the condensation portion “b” for heat release, while the externally exposed heat absorbing extension **22b** at the bottom of the magnetocaloric working unit **10** serves as the evaporation portion “a” for heat absorption. The middle section of the magnetocaloric working unit **10** contacting the heat pipes **25** respectively serves as the evaporation portion “a” when heat is released from the magnetocaloric refrigeration device, and as the condensation portion “b” when heat is absorbed by the magnetocaloric working unit **10**. In this embodiment, the heat pipes **25** operate to release and absorb heat in the same cycle, which may cause high heat loading.

[0041] In another embodiment of the invention, a plurality of magnetocaloric refrigeration devices **1** are assembled together to achieve improved heat efficiency by means of a large number of magnetocaloric working units **10** and heat pipes **25**. FIG. 3A is a perspective view of a heat transfer structure according to a third embodiment of the invention. FIG. 3B is a side view of a magnetocaloric refrigeration device from an angle of view taken along line A-A. Referring to FIG. 3A and FIG. 3B, four heat pipes **25** protrude from the top of the magnetocaloric refrigeration device **1**, and another set of four heat pipes **25** protrude from the bottom of the magnetocaloric refrigeration device **1**. Heat release and absorption are conducted according to the same way as described above.

[0042] FIG. 4A is a perspective view of a heat transfer structure according to a fourth embodiment of the invention. FIG. 4B is a side view of a magnetocaloric refrigeration device from an angle of view taken along line B-B. Heat is conveyed from the evaporated working medium **21** in the heat pipes **25** to a top connecting space **29a**. A bottom connecting space **29b** is further formed in the magnetocaloric refrigeration device **1**, having a smooth heat releasing surface **28a** and a smooth heat absorbing surface **28b**. The

smooth heat absorbing surface **28b** is connected to the cooling receiver device such as a heat sink of a semiconductor device. A weak magnetic field is externally applied to the magnetocaloric refrigeration device to further increase the heat-transfer efficiency.

[0043] In the magnetocaloric refrigeration device **1** of the invention, the one-way heat transfer unit **20** mounted inside or on the magnetocaloric working unit **10** is not limited to the above heat pipes **25**. Any heat transfer member that has heat transfer properties and conveys the working medium **21** can be used in the invention. **FIG. 5** illustrates a magnetocaloric refrigeration device according to a fifth embodiment of the invention. As shown, a plurality of heat pipes **26** can be used to conduct heat to and from the magnetocaloric working unit **10**. The heat pipes **26** are arranged alternately on and protrude from the top and bottom of the magnetocaloric refrigeration device **1**. The working medium **21** (not shown in **FIG. 5**) is contained in the bottom of the heat pipes **26** and conveyed by siphon/capillary attraction along the heat pipe **26**. Heat release and absorption are achieved by applying a periodic magnetic field **5**. A wick structure **23** (not shown in **FIG. 5**) is also formed on the inner walls of the bottoms of the heat pipes **26**, and is wetted by the working medium **21** to increase surface area for heat transfer. The externally exposed heat extensions of the heat pipe **26** can further connect with one another to form a heat space having a structure similar to that shown in **FIG. 4A** and **FIG. 4B**. The one-way heat transfer member is not limited to the heat pipe **25** and the heat pipe **26** described above. Any type of heat transfer member can be used, as long as its shape does not adversely affect the heat-transfer efficiency.

[0044] The invention can be applied in any type of heat circulation system, such as a magnetic refrigerator **3** as shown in **FIG. 6**. As illustrated, a plurality of magnetocaloric refrigeration devices **1** are arranged in series. One or more moving members **9** generating a magnetic field **5** of about 1 Tesla, are mounted adjacent to the devices **1**. The moving members **9** are permanent magnets **8**, and move along the magnetocaloric refrigeration devices **1** at a predetermined speed to generate periodic magnetic fields **5**. The heat pipes **25** are respectively provided with a heat exchanger and at least one fin **50**. A working medium **51** flows through the heat exchanger to provide a refrigeration effect similar to the prior art. Since the construction of the system is simple, control of the moving members **9** is easily achieved. Furthermore, no additional valve is needed to switch the working medium **51**, which greatly improves over on the conventional magnetocaloric refrigeration system.

[0045] In another embodiment of the invention, the external magnetic field **5** is generated in a manner different from the above description. A plurality of equally spaced electromagnets **7** are mounted near one side of the series-arranged magnetocaloric refrigeration devices **1**. A controller alternately magnetizes/demagnetizes the electromagnets **7** at a constant rate to respectively produce a magnetized electromagnet **7a** and a demagnetized electromagnet **7b**, which provides the same effect as the above movable permanent magnet **8**. A magnetic field **5** is applied to the magnetocaloric working unit **10** of the magnetocaloric refrigeration device **1**. The magnetic refrigerator **3** experiences a higher magnetic field **5** than that of the prior art and therefore provides higher refrigeration efficiency than in the prior art. Furthermore, all the constituting elements of the device **1** are

controlled electromagnetically (instead of by traditional mechanical control). Thereby, mechanical wear and noise can be eliminated, while operating stability and processibility of the whole device is increased.

[0046] Aside the above construction of magnetic refrigerator **3**, magnetocaloric refrigeration devices **1** can be arranged according to other assembly schemes. For example, the magnetocaloric refrigeration devices **1** may be stacked up to form a multi-layered refrigeration system **6**, as shown in **FIG. 8**. The magnetocaloric material **11** is used in different ratios in order to tolerate a temperature range larger than that of the prior art. In system **6**, a lower layer is made of an alloy of $Gd_5(SixG_{1-x})_4$ and an upper layer is made of $Gd_5(Si_{1.985}Ge_{1.985}Ga_{0.03})$. The heat from the medium to be cooled down is subsequently transferred outward through the lower and upper layers. Heat at temperatures between, for example, $3^\circ C.$ and $37^\circ C.$, is transferred through the multi-layers. The working medium **21** can be varied according to the material **11** of the heat pipe **25**. The arrangement and number of the material layers as well as the alloy composition ratio and type of the working medium can be appropriately chosen to obtain optimal heat-transfer efficiency depending on the system requirements.

[0047] The configuration of the magnetocaloric working unit **10** and the one-way heat transfer member **20**, and the way to generate the magnetic field **5**, are not limited to the above description. The application of the invention includes, but is not limited to, a magnet refrigerator **3**, a refrigeration circulation system, an electronic heat dissipation system, a microfluid system, and the production of low-temperature liquid nitrogen used in a fuel battery.

[0048] The magnetocaloric refrigeration device of the invention has advantages such as high heat-transfer efficiency, a simplified and smaller structure, a low production cost, low environmental pollution, stable operation and low energy-consumption. If the invention is implemented in a magnetocaloric refrigerator, the gears and valves that were necessary in the conventional refrigerator are eliminated, which thus reduces mechanical wear and noise produced during operation of the system, and increases the operation stability.

[0049] It should be apparent to those skilled in the art that the above description is only illustrative of specific embodiments and examples of the invention. The invention should therefore cover various modifications and variations made to the herein-described structure and operation of the invention, provided they fall within the scope of the invention as defined in the following appended claims.

What is claimed is:

1. A magnetocaloric refrigeration device for use in a controllable magnetic field, comprising a heat release/absorption module,

wherein the heat release/absorption module comprising:

a magnetocaloric working unit made of a magnetocaloric material, wherein the temperature of the magnetocaloric working unit changes as the magnetic field is alternately applied and removed; and

at least one heat pipe having an evaporation portion and a condensation portion, wherein at least one of the evaporation and condensation portions is connected to

the magnetocaloric working unit such that heat is transferred from the evaporation portion to the condensation portion by a working medium contained in the heat pipe responsive to the temperature change of the magnetocaloric working unit.

2. The magnetocaloric refrigeration device of claim 1, wherein the heat pipe is a one-way heat transfer element.

3. The magnetocaloric refrigeration device of claim 1, wherein the heat pipe is attached to an external surface of the magnetocaloric working unit.

4. The magnetocaloric refrigeration device of claim 1, wherein the heat pipe is inserted in the magnetocaloric working unit.

5. The magnetocaloric refrigeration device of claim 1, wherein if the heat release/absorption module has only one heat pipe, the evaporation and condensation portions of the heat pipe are both connected to the heat release/absorption module for heat release and heat absorption.

6. The magnetocaloric refrigeration device of claim 5, wherein the condensation portion of the heat pipe has an externally exposed heat release extension formed through a top of the magnetocaloric working unit, and the evaporation portion thereof has an externally exposed heat absorption extension formed through a bottom of the magnetocaloric working unit.

7. The magnetocaloric refrigeration device of claim 1, wherein if the heat release/absorption module has at least two heat pipes, the heat pipes are respectively a heat releasing pipe mounted on the magnetocaloric working unit via the evaporation portion thereof, and a heat absorbing pipe mounted on the magnetocaloric working unit via the condensation portion thereof.

8. The magnetocaloric refrigeration device of claim 7, wherein the condensation portion of the heat releasing pipe has an externally exposed heat release extension formed through a top of the magnetocaloric working unit, and the evaporation portion of the heat absorbing pipe has an externally exposed heat absorption extension formed through a bottom of the magnetocaloric working unit.

9. The magnetocaloric refrigeration device of claim 1, wherein the heat release extensions of the heat releasing pipes are spaced from or communicative with each other.

10. The magnetocaloric refrigeration device of claim 1, wherein the heat absorption extensions of the heat absorbing pipes are spaced from or communicative with each other.

11. The magnetocaloric refrigeration device of claim 1, wherein a wick structure is formed on an inner wall of the heat pipe.

12. The magnetocaloric refrigeration device of claim 1, wherein an inner wall of the heat pipe is bare and featureless.

13. The magnetocaloric refrigeration device of claim 1, wherein the magnetocaloric material is composed of Gd, Si and Ge in a relation of $Gd_5(Si_xGe_{1-x})_4$.

14. The magnetocaloric refrigeration device of claim 1, wherein the magnetocaloric working unit is filled with powders of the magnetocaloric material.

15. The magnetocaloric refrigeration device of claim 1, wherein the magnetocaloric working unit is made of an alloy film formed from a deposition of the magnetocaloric material.

16. The magnetocaloric refrigeration device of claim 1, wherein a plurality of resin layers are formed in the magnetocaloric working unit for partitioning the magnetocaloric material.

17. The magnetocaloric refrigeration device of claim 1, wherein the controllable magnetic field is formed by a stationary electromagnet that alternately magnetizes and demagnetizes.

18. The magnetocaloric refrigeration device of claim 1, wherein the controllable magnetic field is formed by a stationary superconductive magnet that alternately magnetizes and demagnetizes.

19. The magnetocaloric refrigeration device of claim 1, wherein the controllable magnetic field is formed by a movable permanent magnet.

20. The magnetocaloric refrigeration device of claim 1, further comprising a heat exchanger through which the working medium transfers the heat so as to form a magnetic refrigerator.

* * * * *