



(19) **United States**

(12) **Patent Application Publication**

Roth

(10) **Pub. No.: US 2004/0117032 A1**

(43) **Pub. Date:**

Jun. 17, 2004

(54) **DEVICES FOR LESS-INVASIVE INTRACARDIAC INTERVENTIONS**

(52) **U.S. Cl.** 623/23.72; 606/1

(76) **Inventor:** Alex T. Roth, Redwood City, CA (US)

(57) **ABSTRACT**

Correspondence Address:
PHILIP S. JOHNSON
JOHNSON & JOHNSON
ONE JOHNSON & JOHNSON PLAZA
NEW BRUNSWICK, NJ 08933-7003 (US)

Devices, systems, and methods are provided for accessing the interior of the heart and performing procedures therein while the heart is beating. In one embodiment, a tubular access device having an inner lumen is provided for positioning through a penetration in a muscular wall of the heart, the access device having a means for sealing within the penetration to inhibit leakage of blood through the penetration. The sealing means may comprise a balloon or flange on the access device, or a suture placed in the heart wall to gather the heart tissue against the access device. An obturator is removably positionable in the inner lumen of the access device, the obturator having a cutting means at its distal end for penetrating the muscular wall of the heart. The access device is preferably positioned through an intercostal space and through the muscular wall of the heart. Elongated instruments may be introduced through the tubular access device into an interior chamber of the heart to perform procedures such as septal defect repair and electrophysiological mapping and ablation. A method of septal defect repair includes positioning a tubular access device percutaneously through an intercostal space and through a penetration in a muscular wall of the heart, passing one or more instruments through an inner lumen of the tubular access device into an interior chamber of the heart, and using the instruments to close the septal defect. Devices and methods for closing the septal defect with either sutures or with patch-type devices are disclosed.

(21) **Appl. No.:** 10/719,034

(22) **Filed:** Nov. 21, 2003

Related U.S. Application Data

(63) Continuation of application No. 09/941,188, filed on Aug. 28, 2001, now Pat. No. 6,651,672, which is a continuation of application No. 08/662,119, filed on Jun. 12, 1996, now Pat. No. 6,346,074, which is a continuation-in-part of application No. 08/425,179, filed on Apr. 20, 1995, now Pat. No. 5,797,960, which is a continuation-in-part of application No. 08/163,241, filed on Dec. 6, 1993, now Pat. No. 5,571,215, which is a continuation-in-part of application No. 08/023,778, filed on Feb. 22, 1993, now Pat. No. 5,452,733.

Publication Classification

(51) **Int. Cl.⁷** A61F 2/02

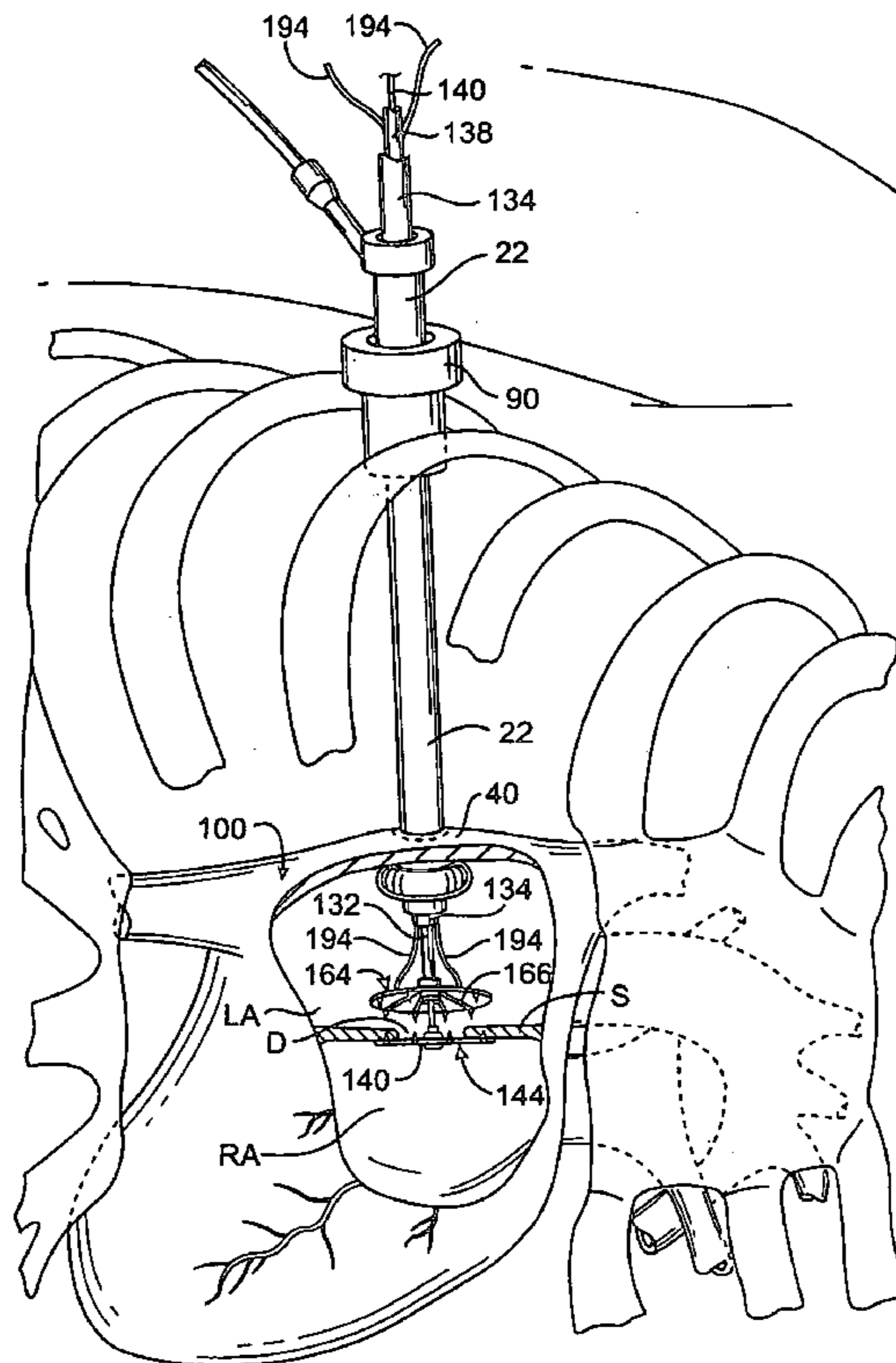

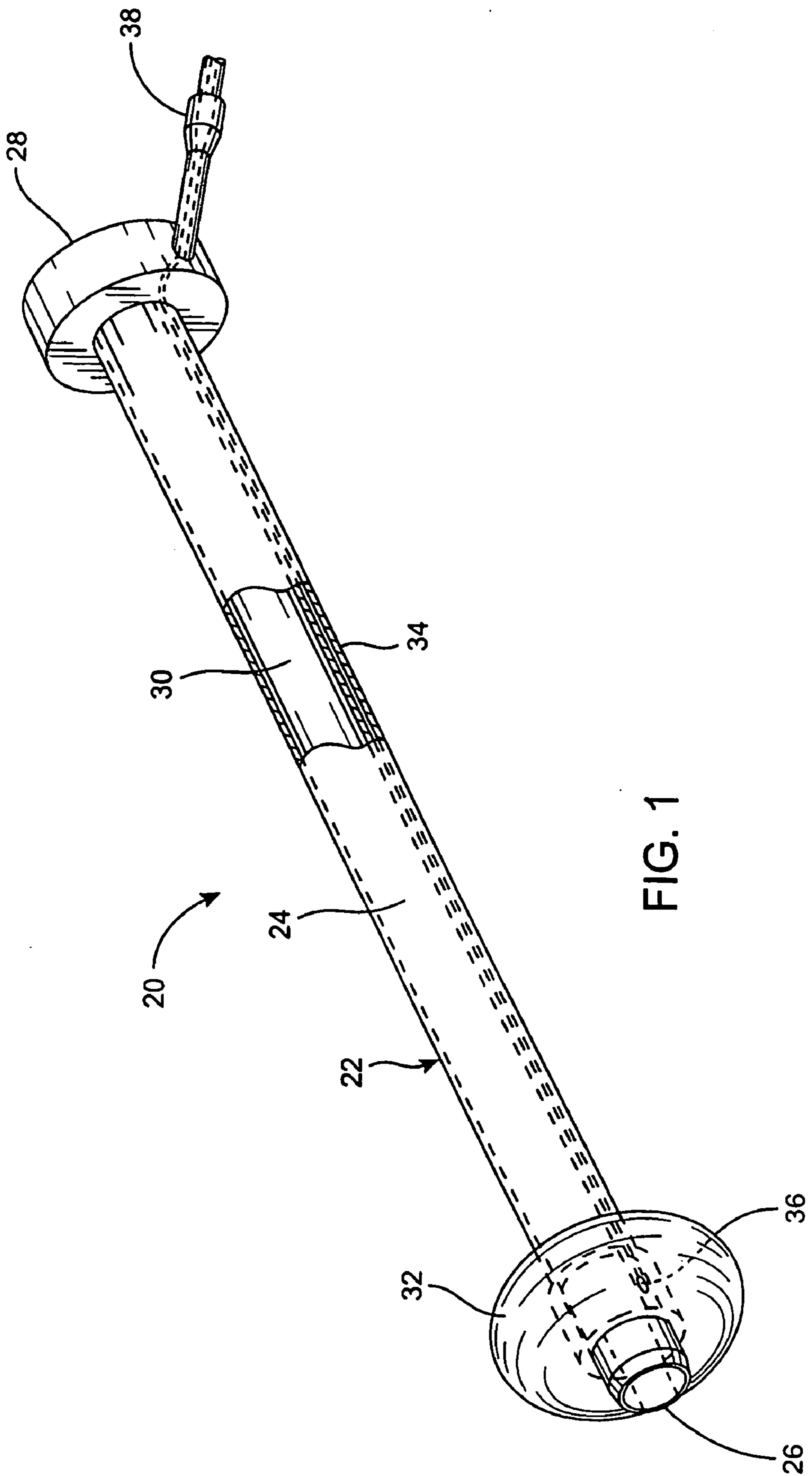

FIG. 1

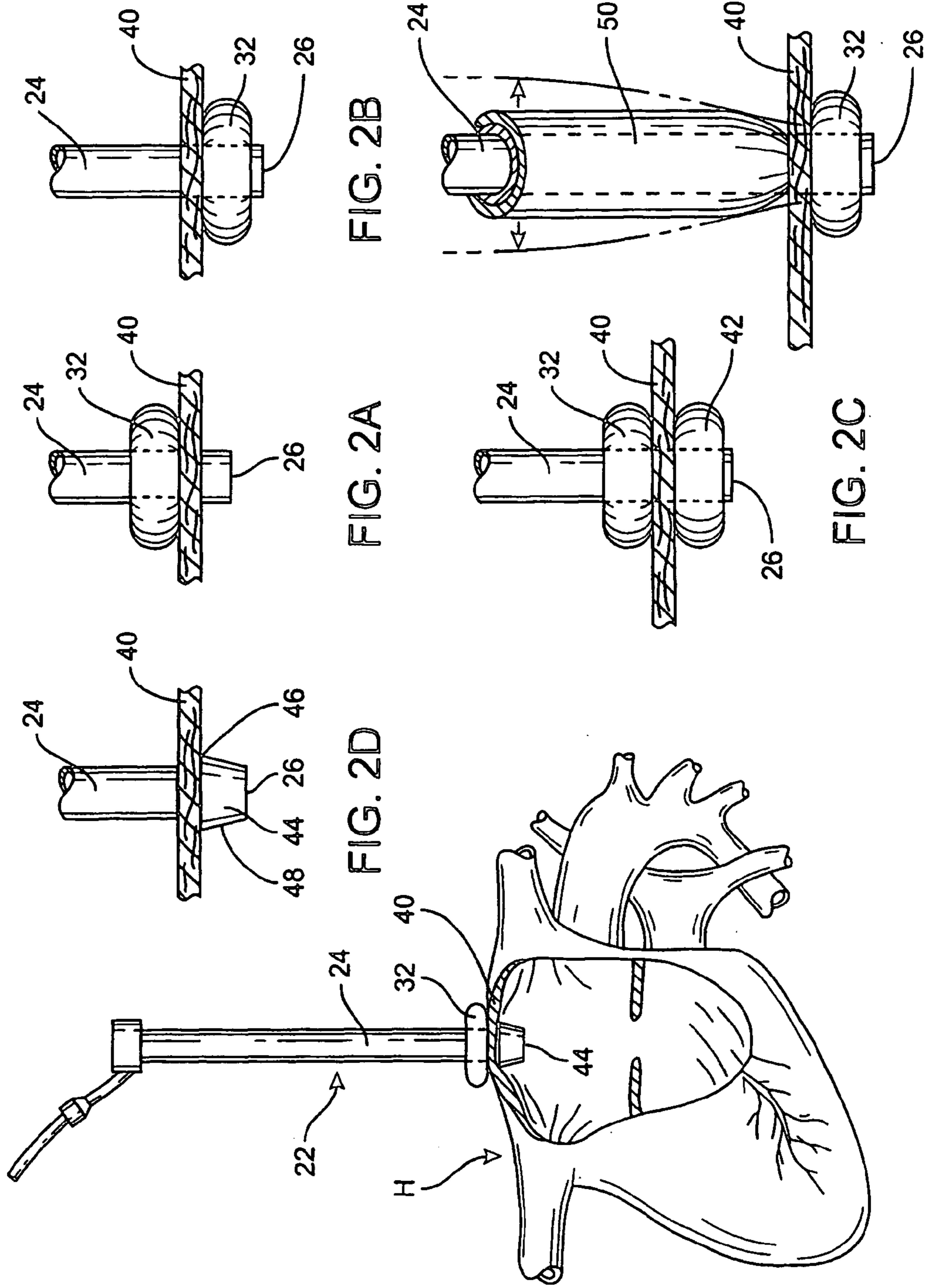

FIG. 2A

FIG. 2B

FIG. 2C

FIG. 2D

FIG. 2E

FIG. 2

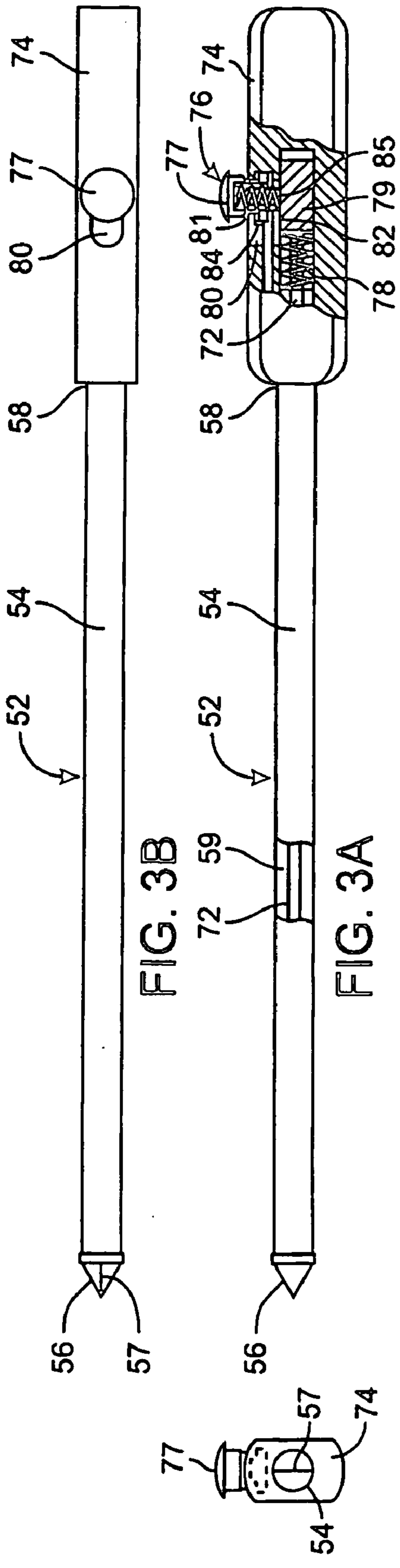

FIG. 3C

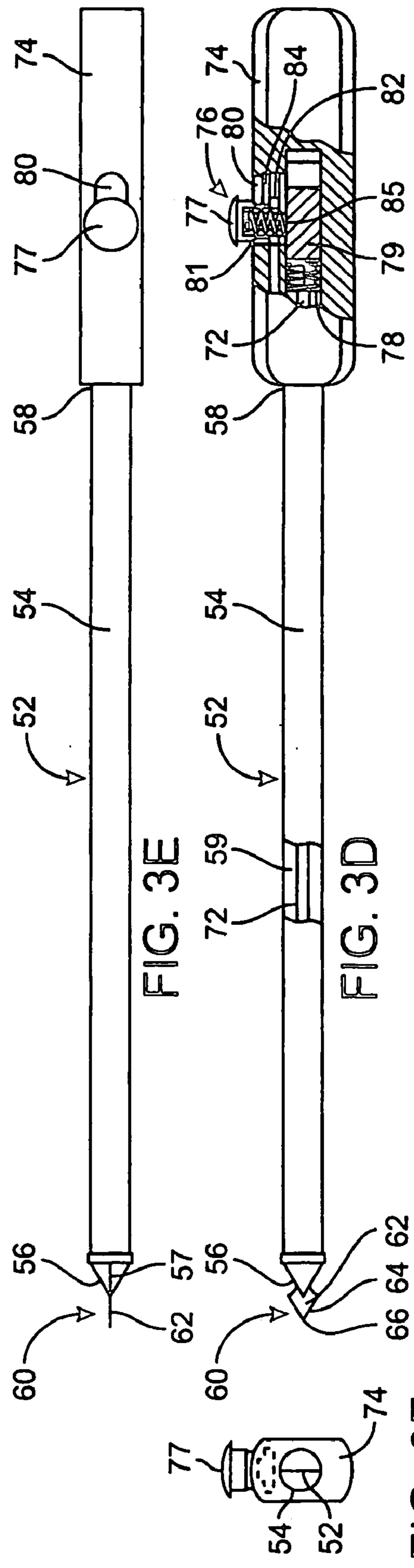

FIG. 3F

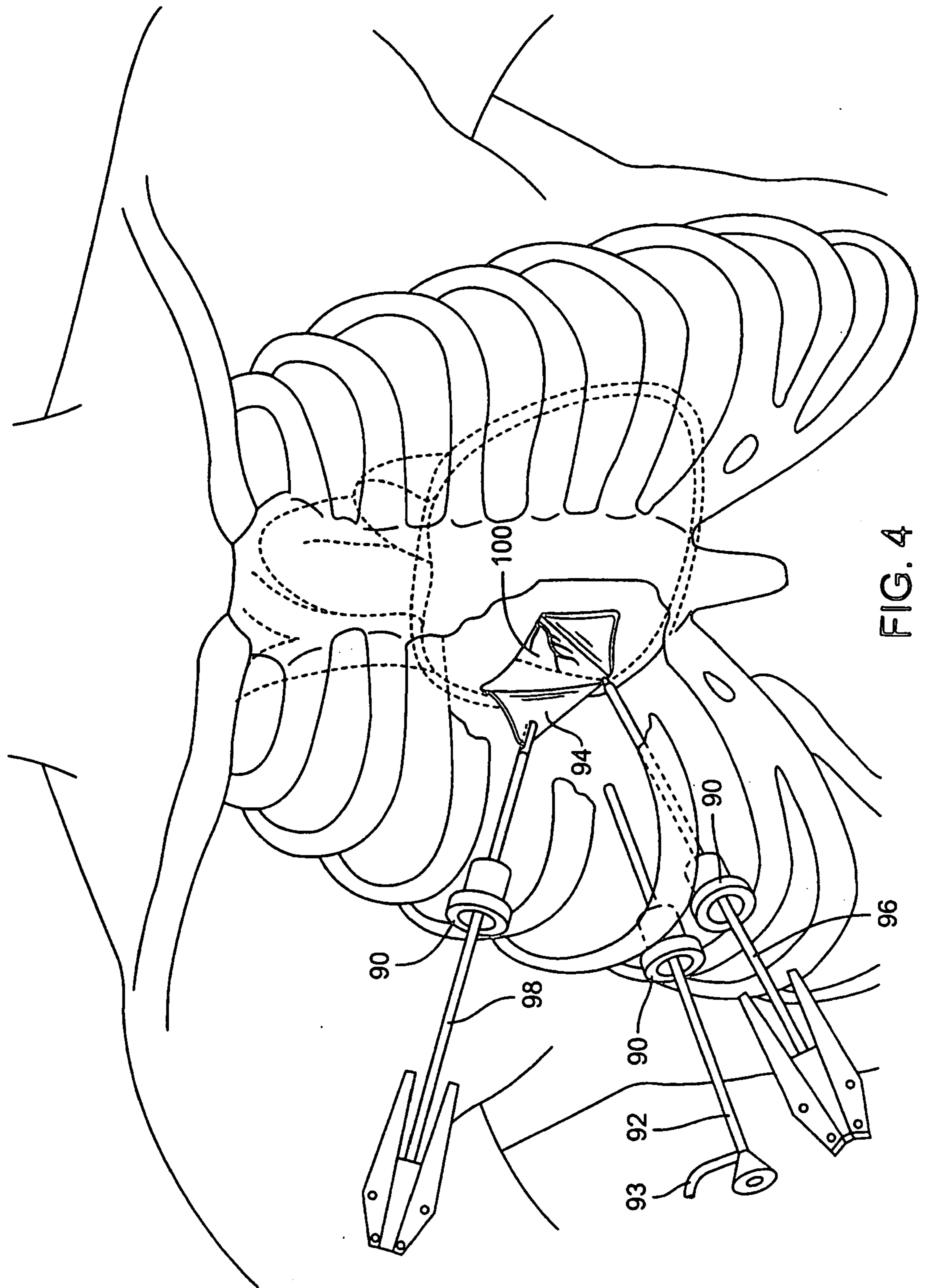

FIG. 4

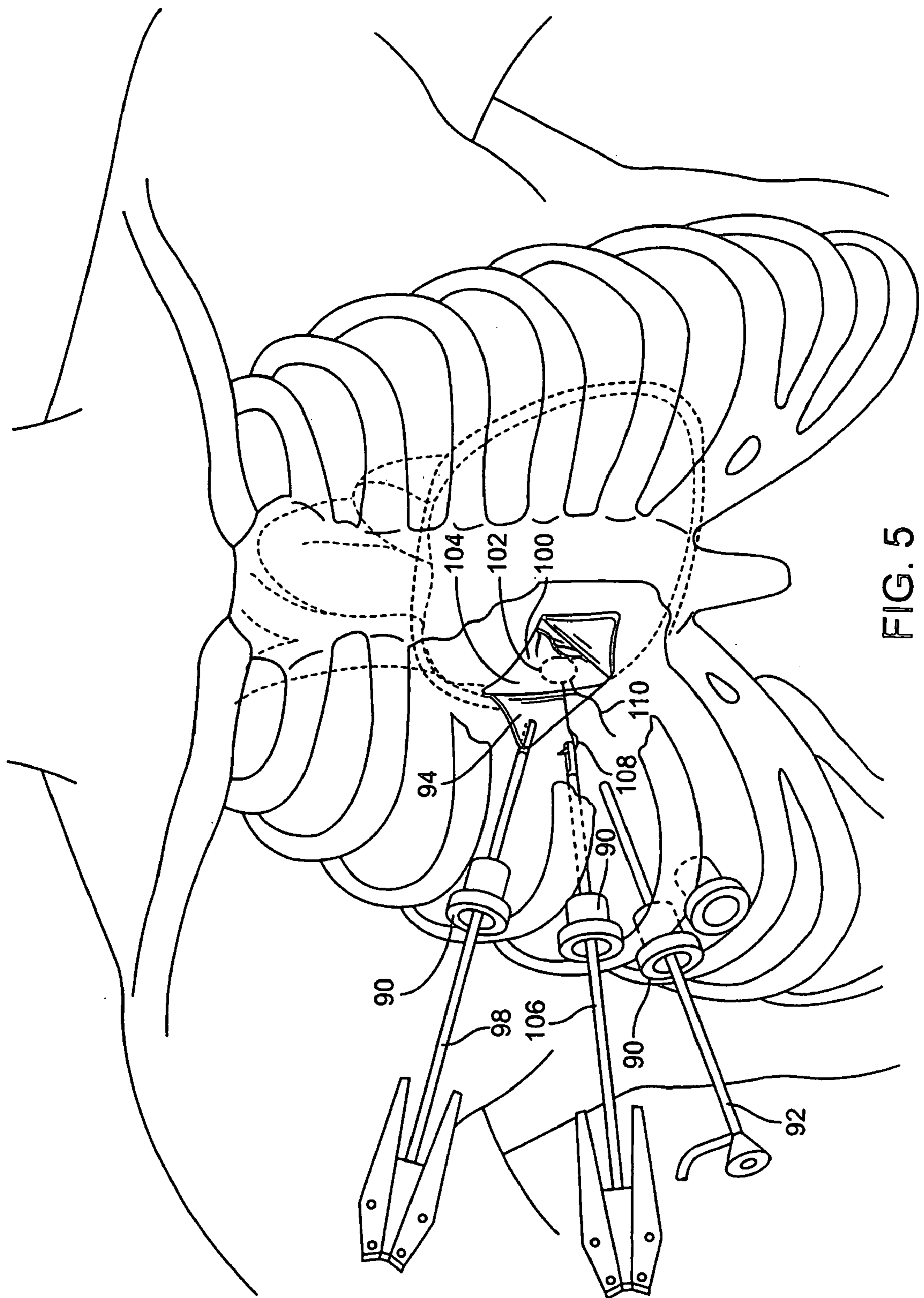
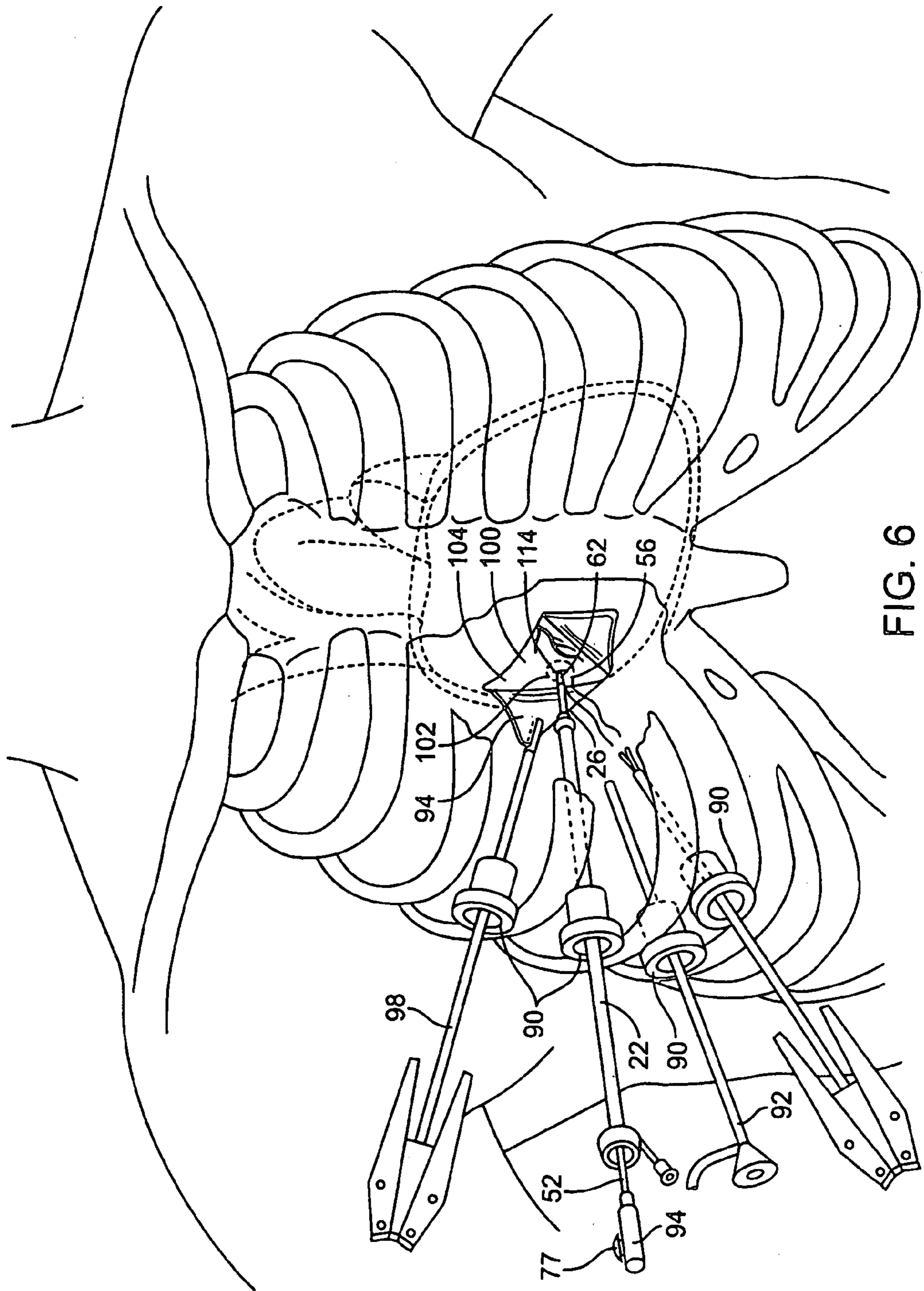

FIG. 5



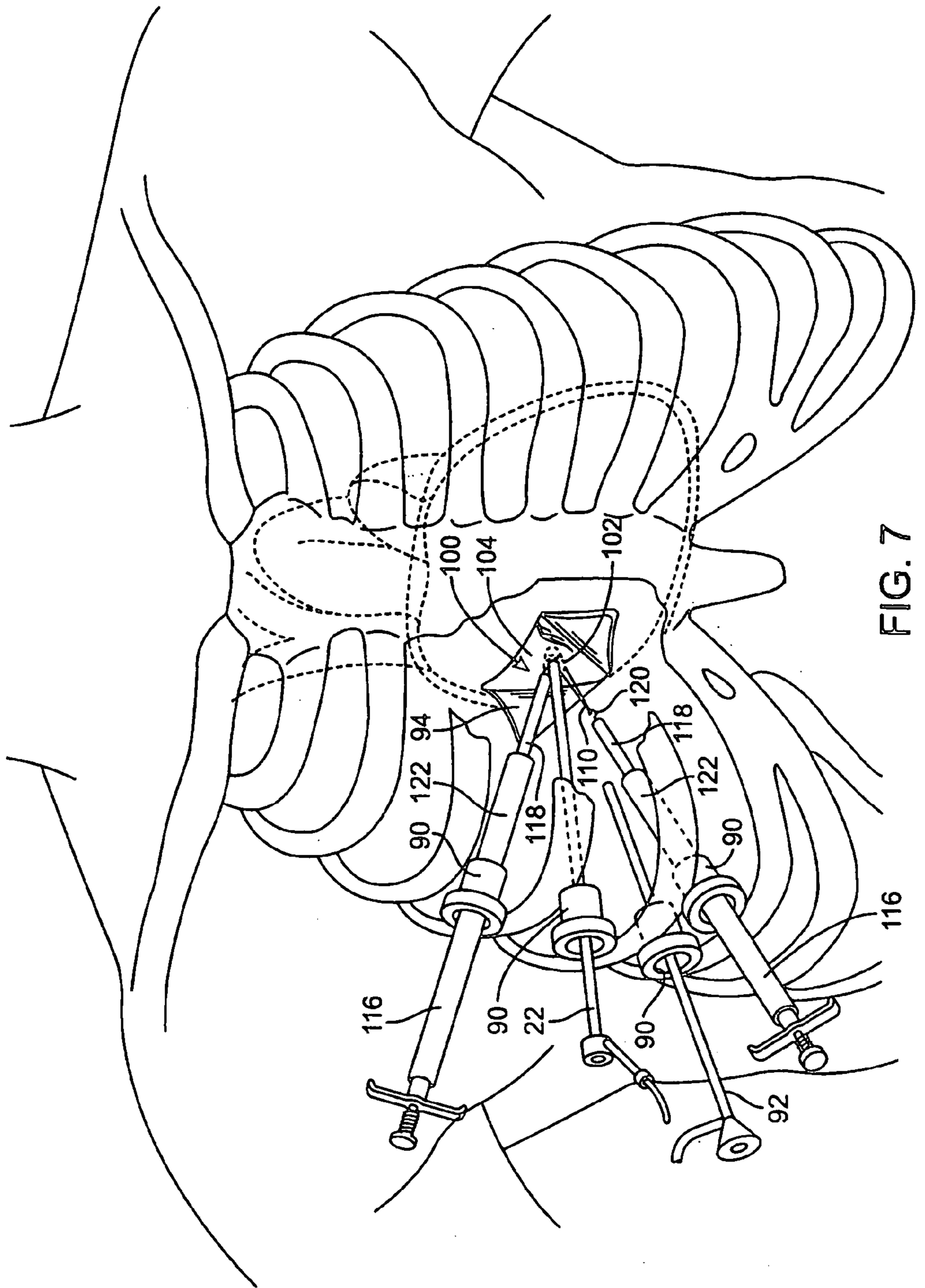

FIG. 7

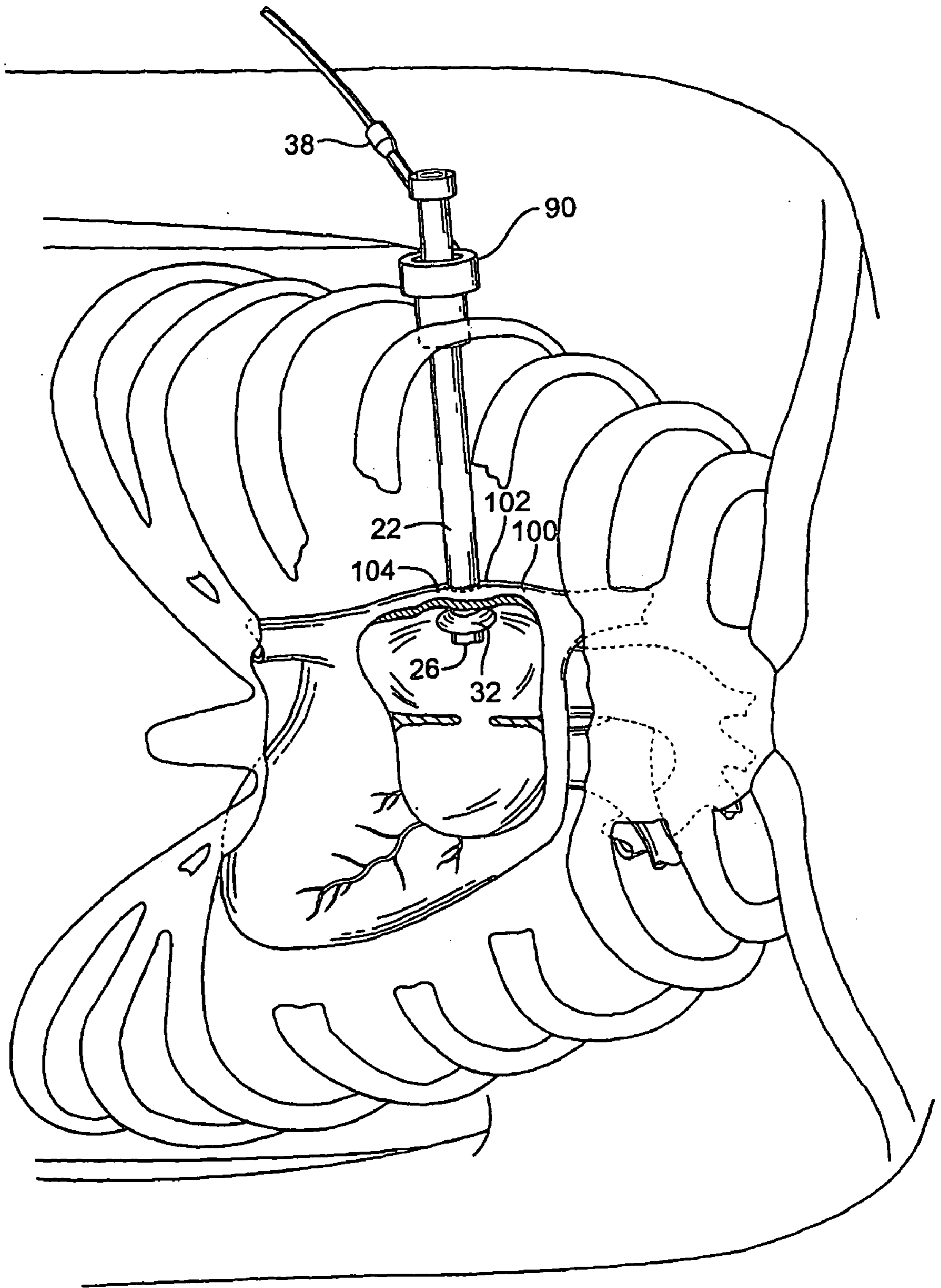

FIG. 8A

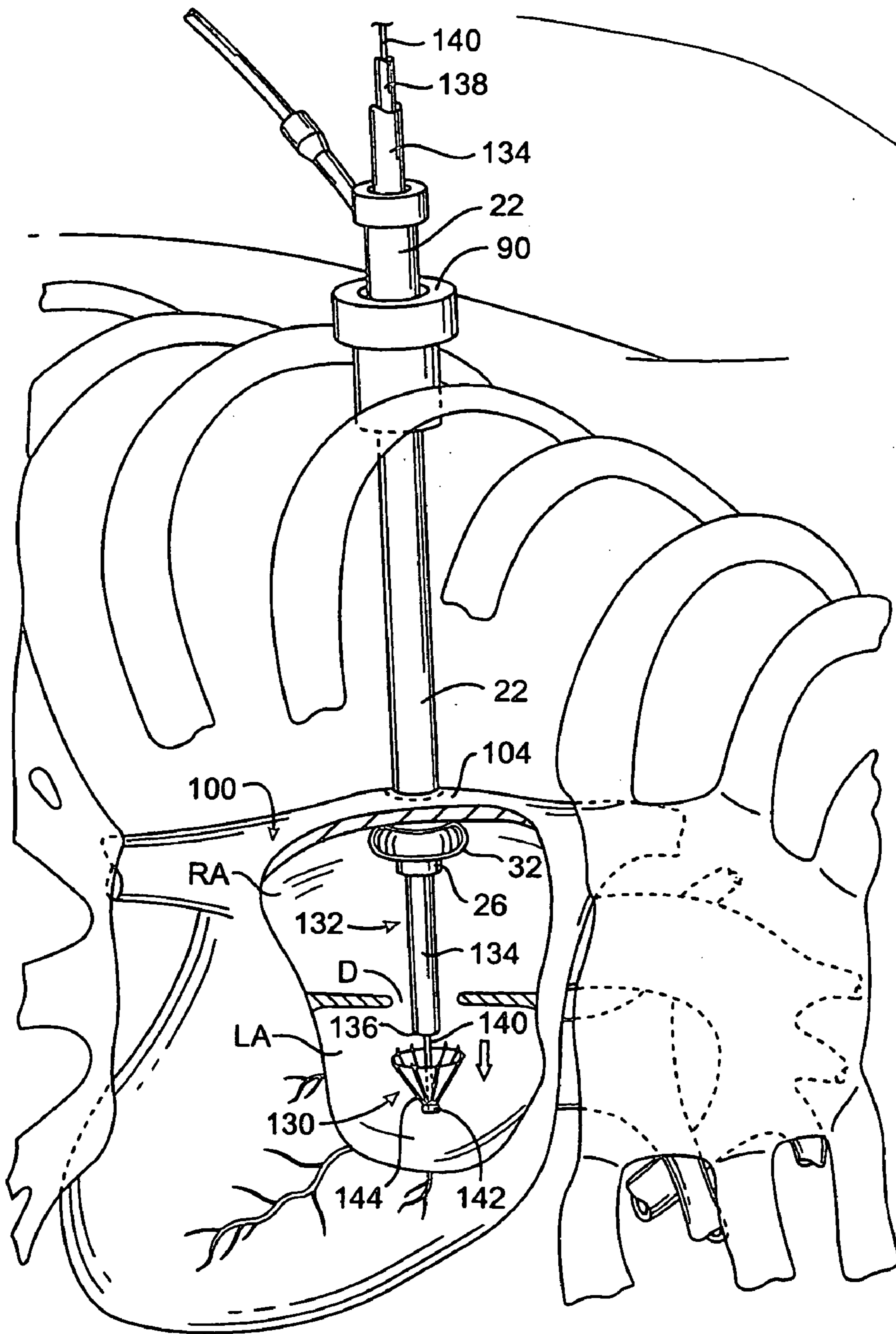

FIG. 9

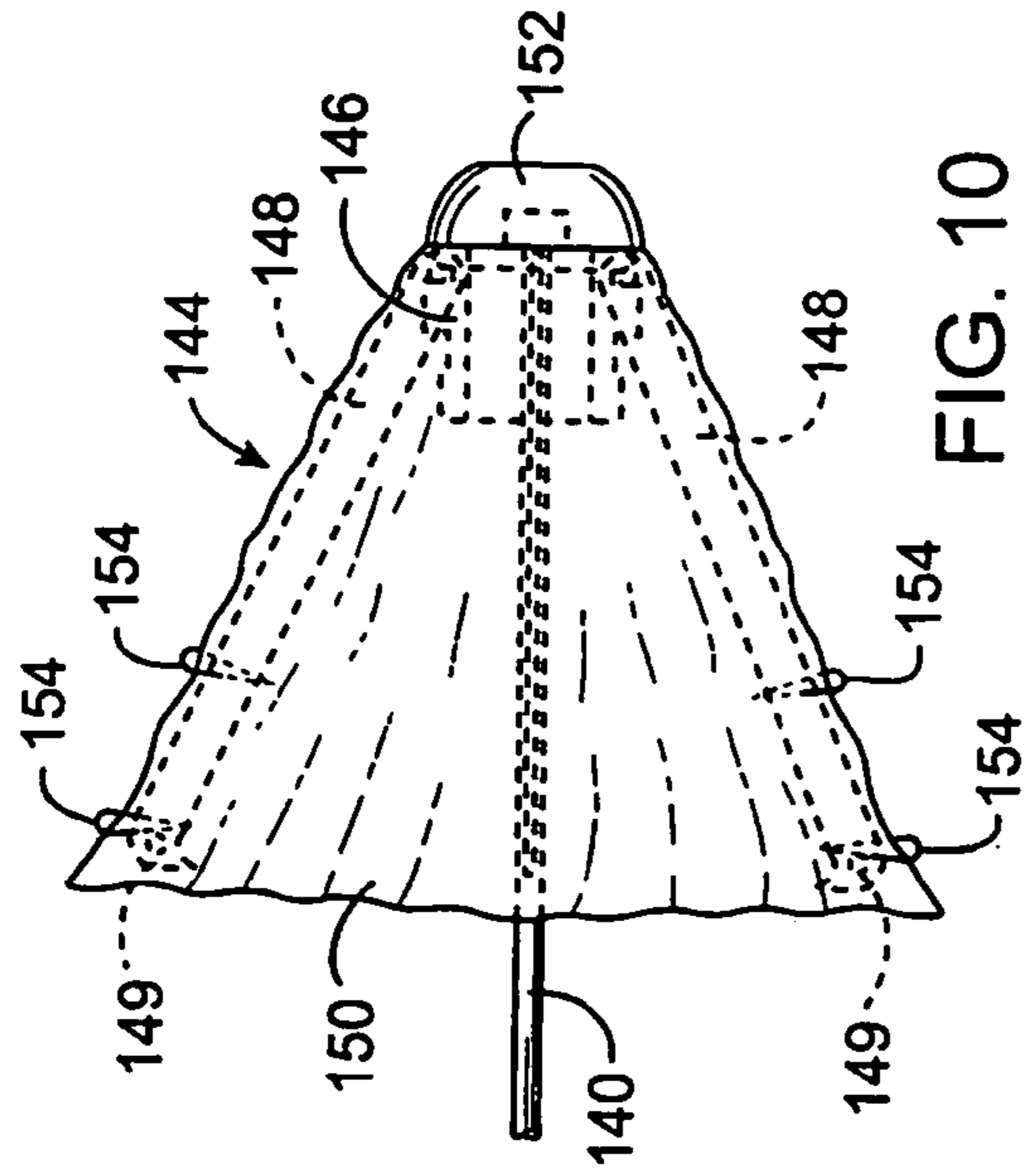

FIG. 10

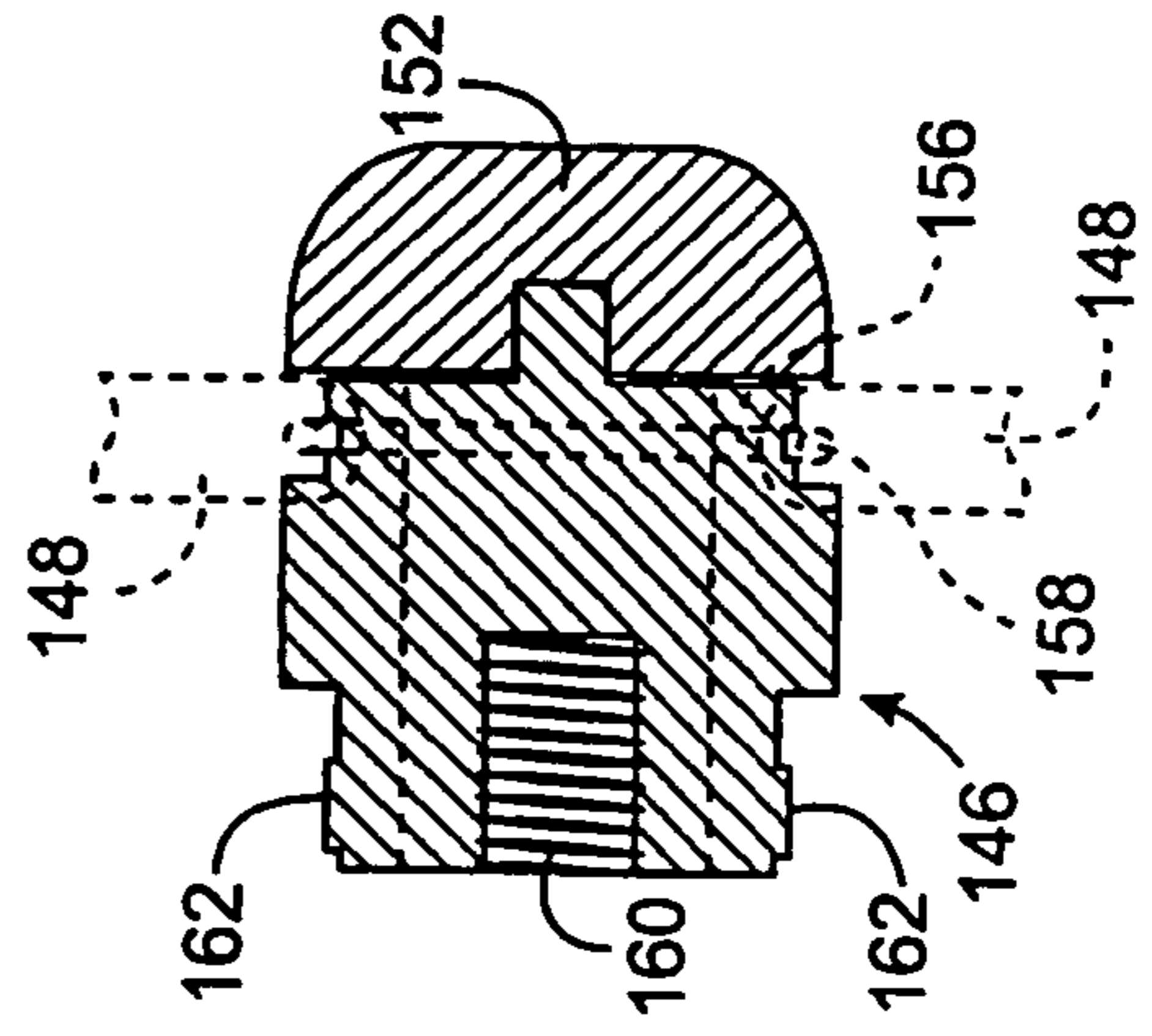

FIG. 11A

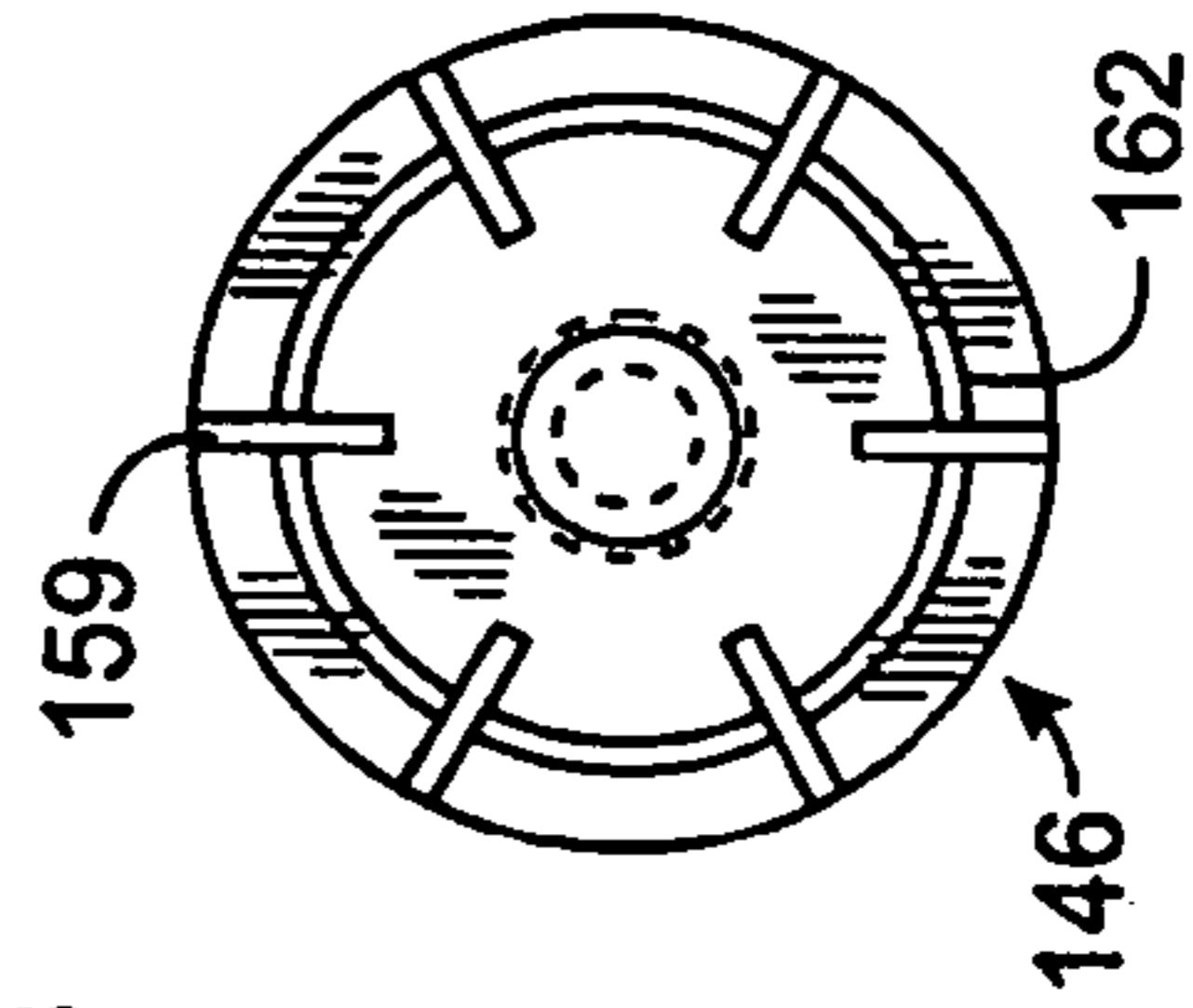

FIG. 11B

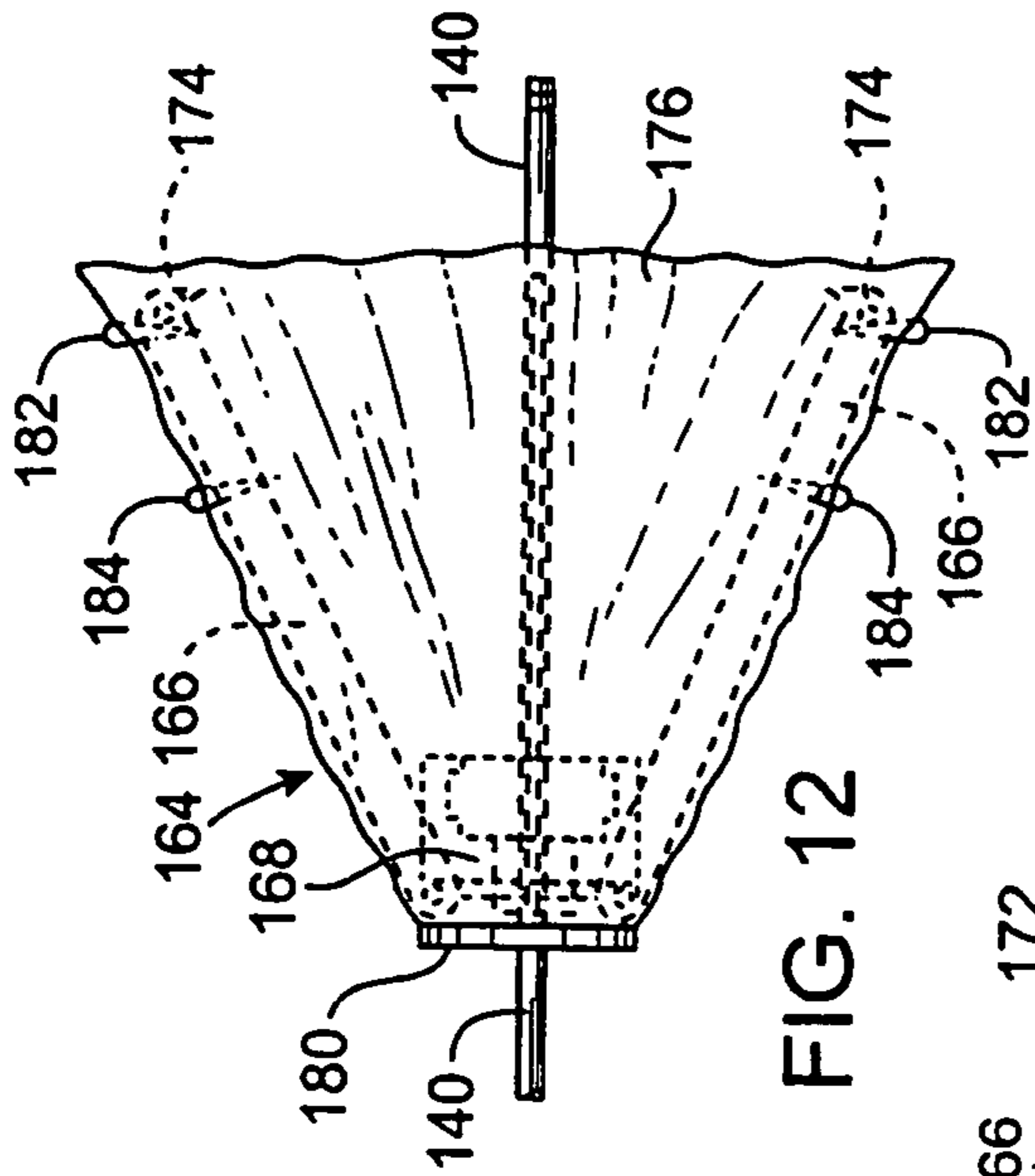

FIG. 12

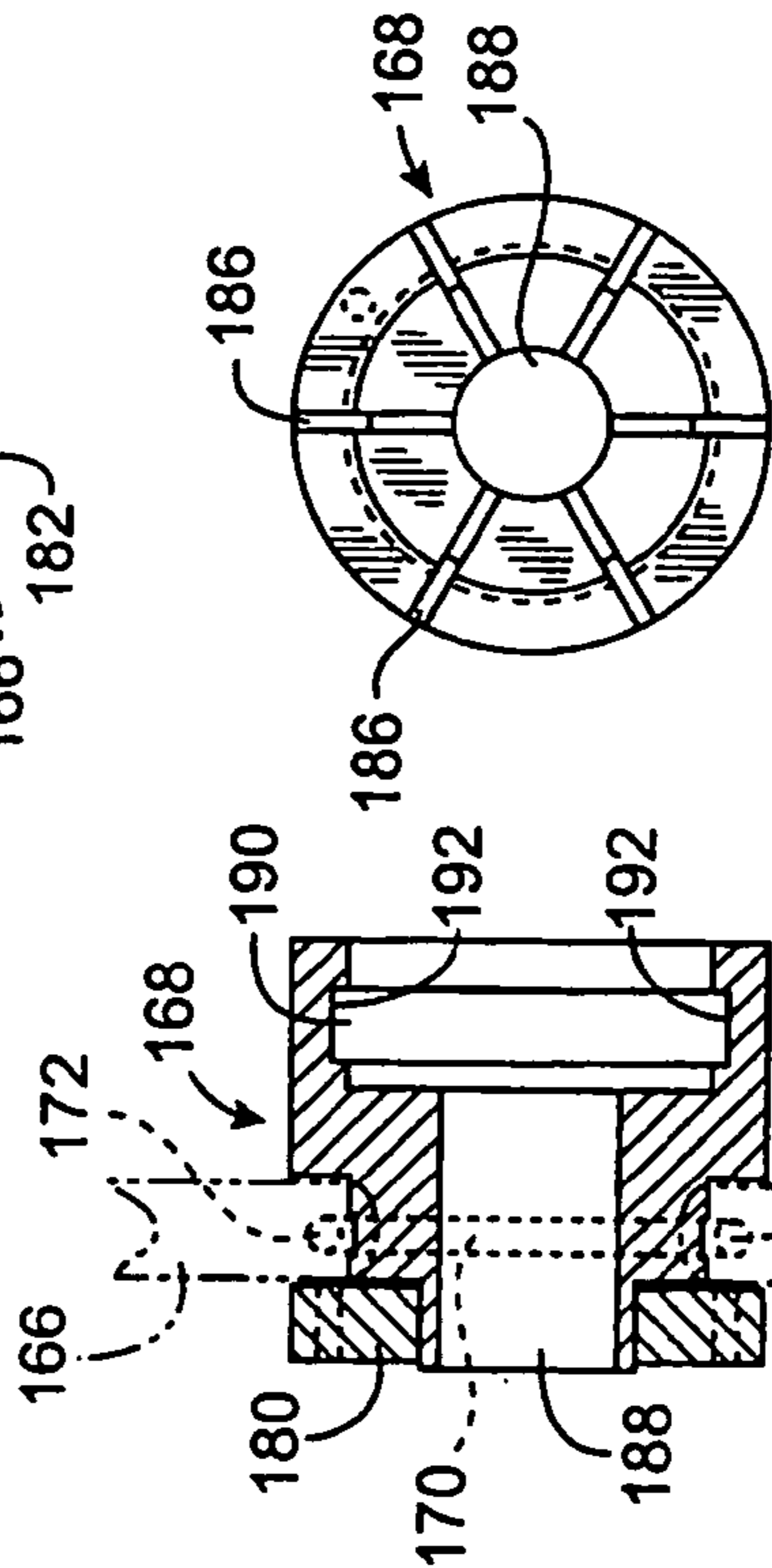

FIG. 13A

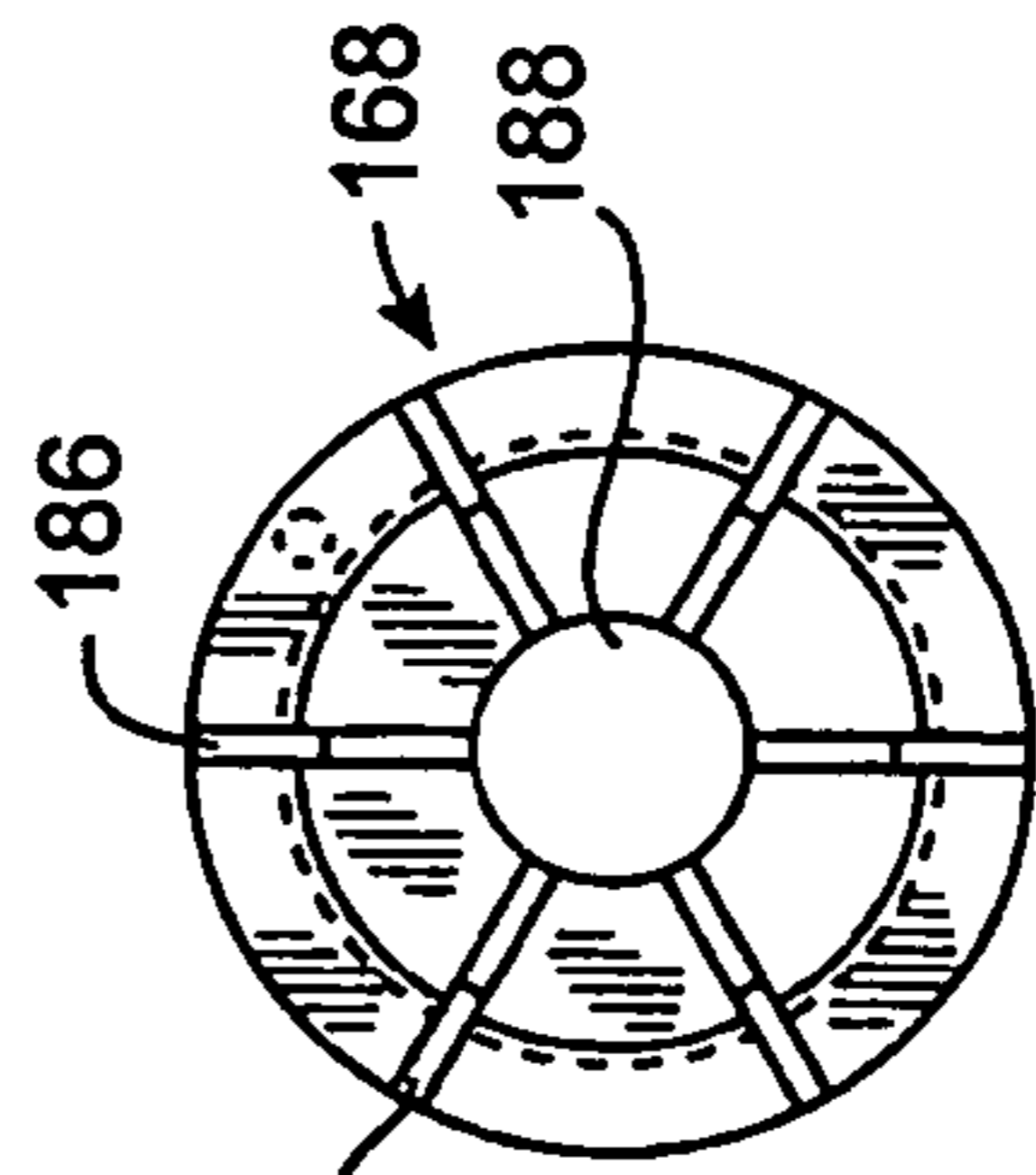

FIG. 13B

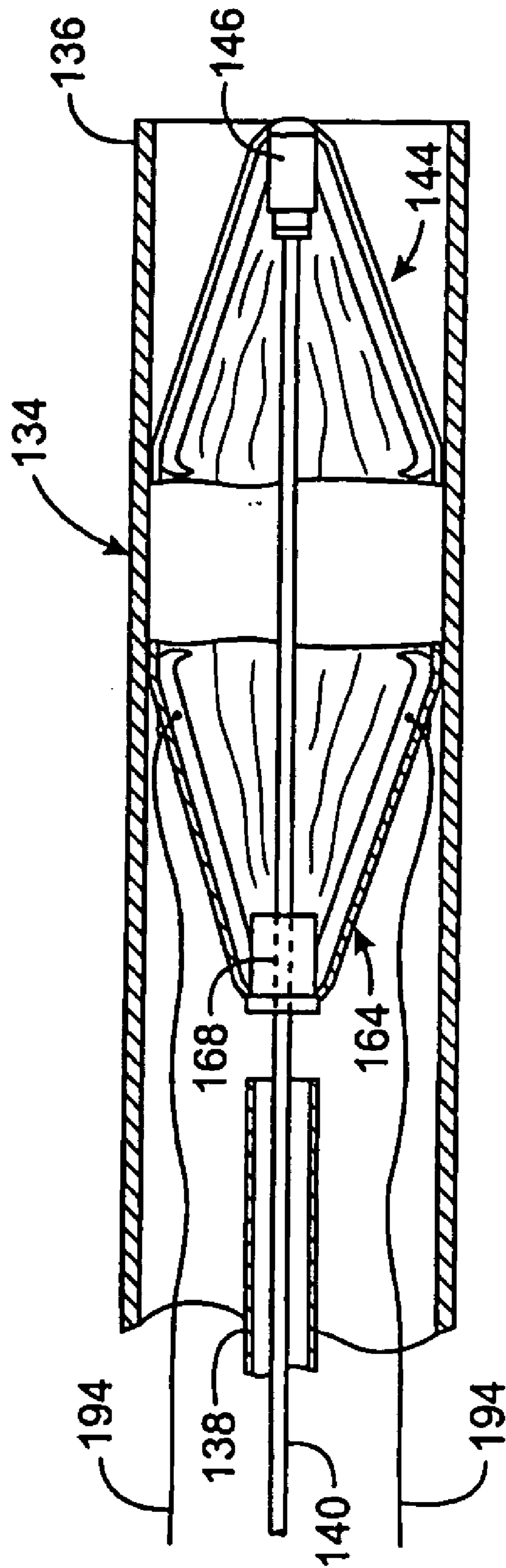

FIG. 14

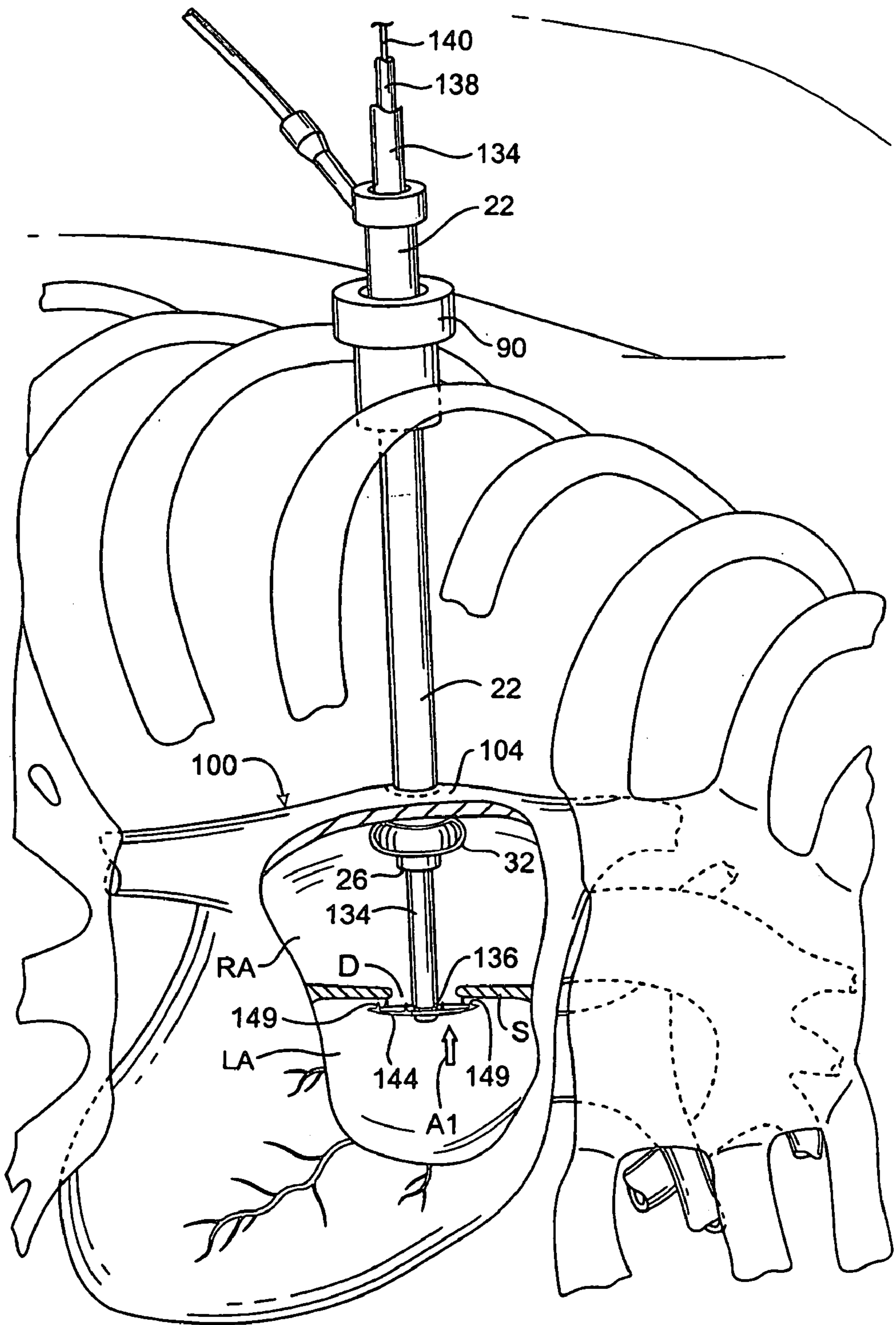

FIG. 15

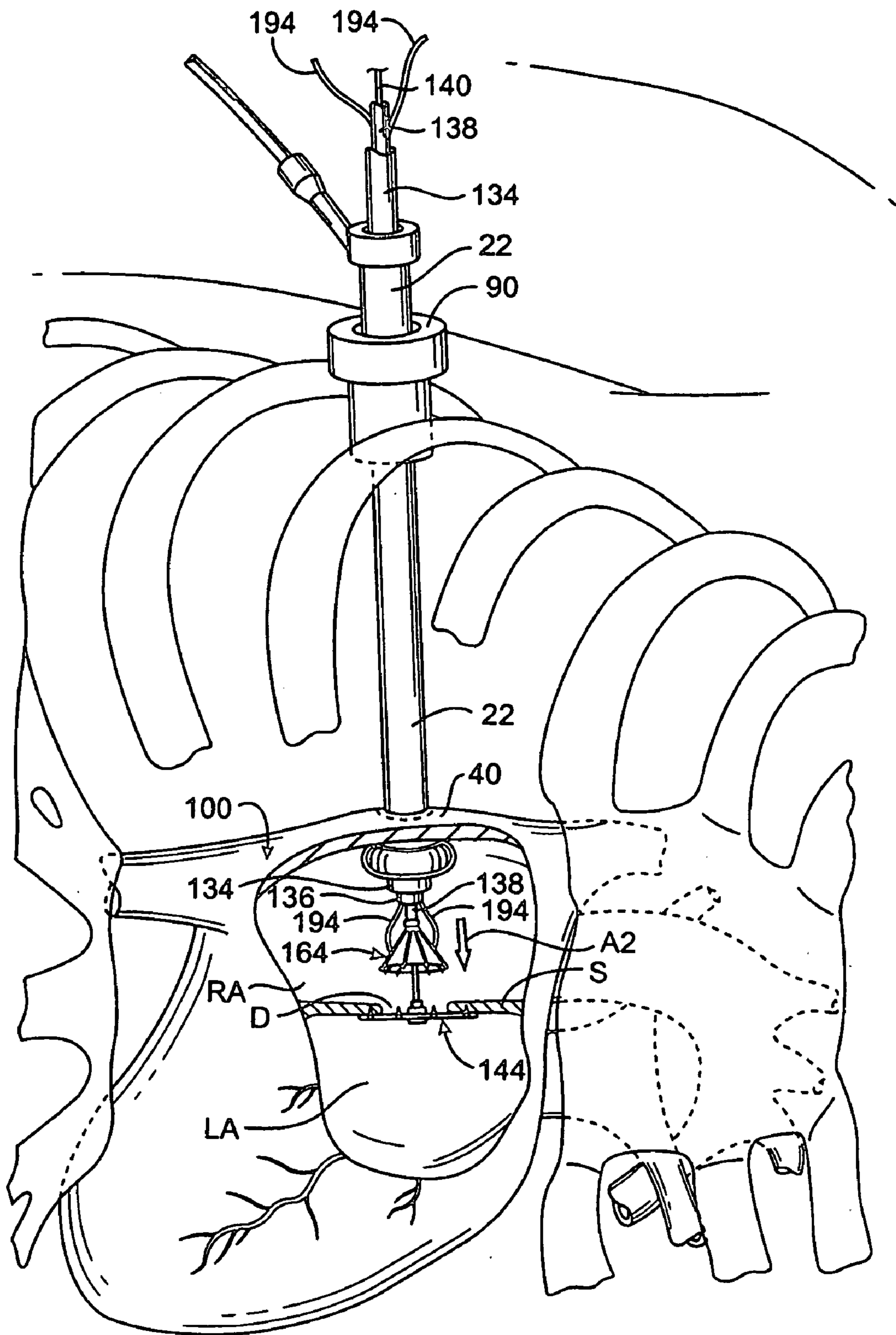

FIG. 16

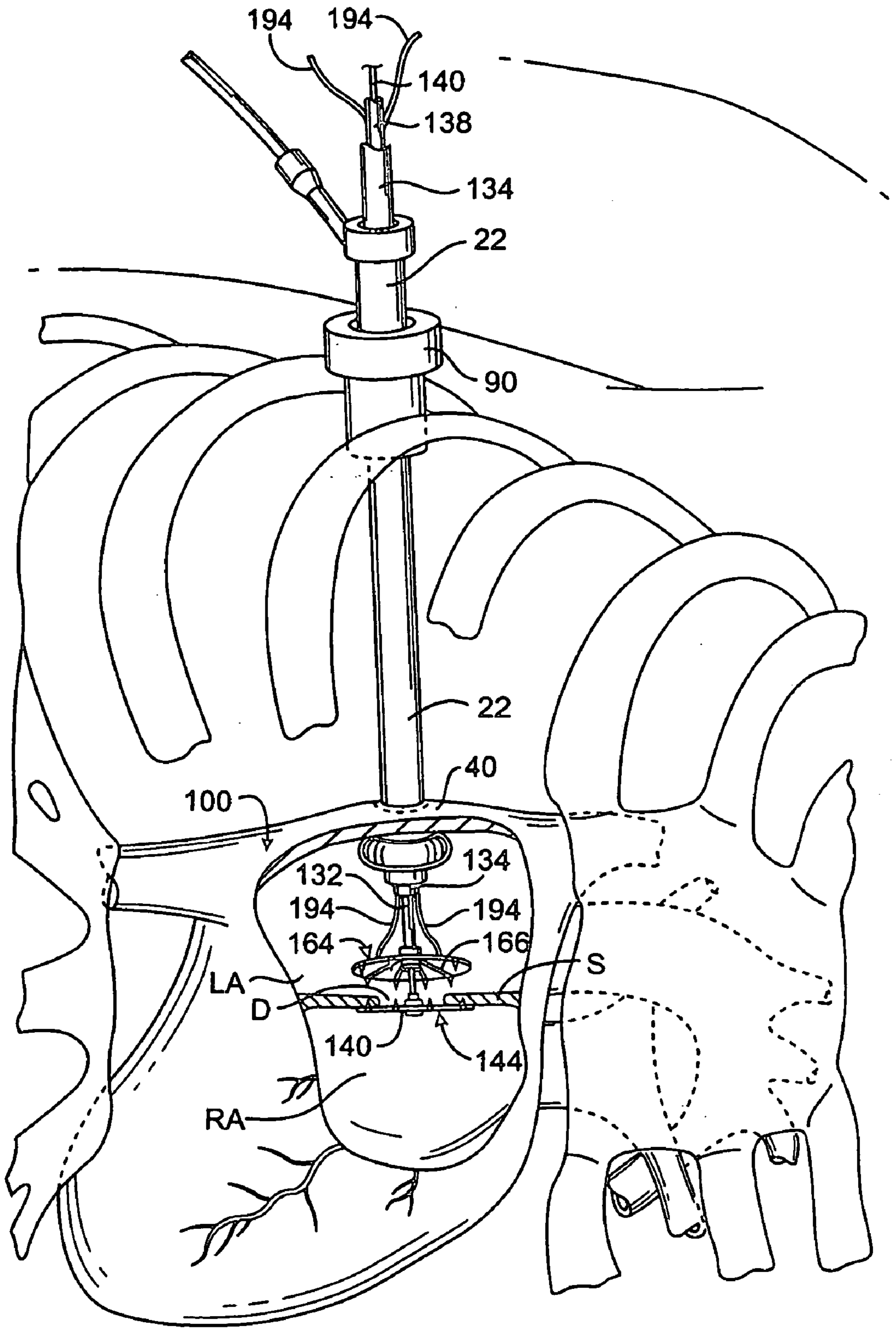

FIG. 17

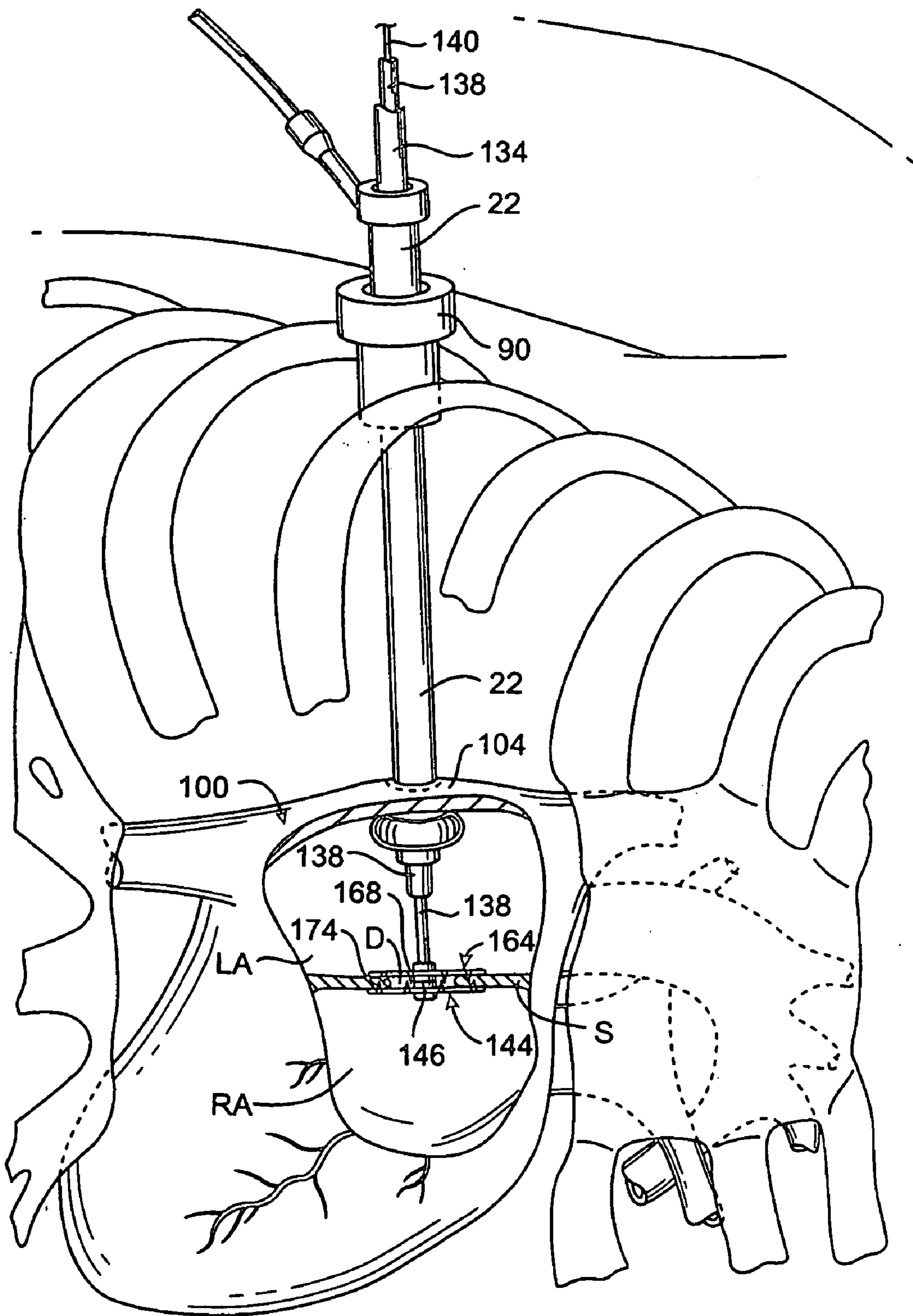

FIG. 18

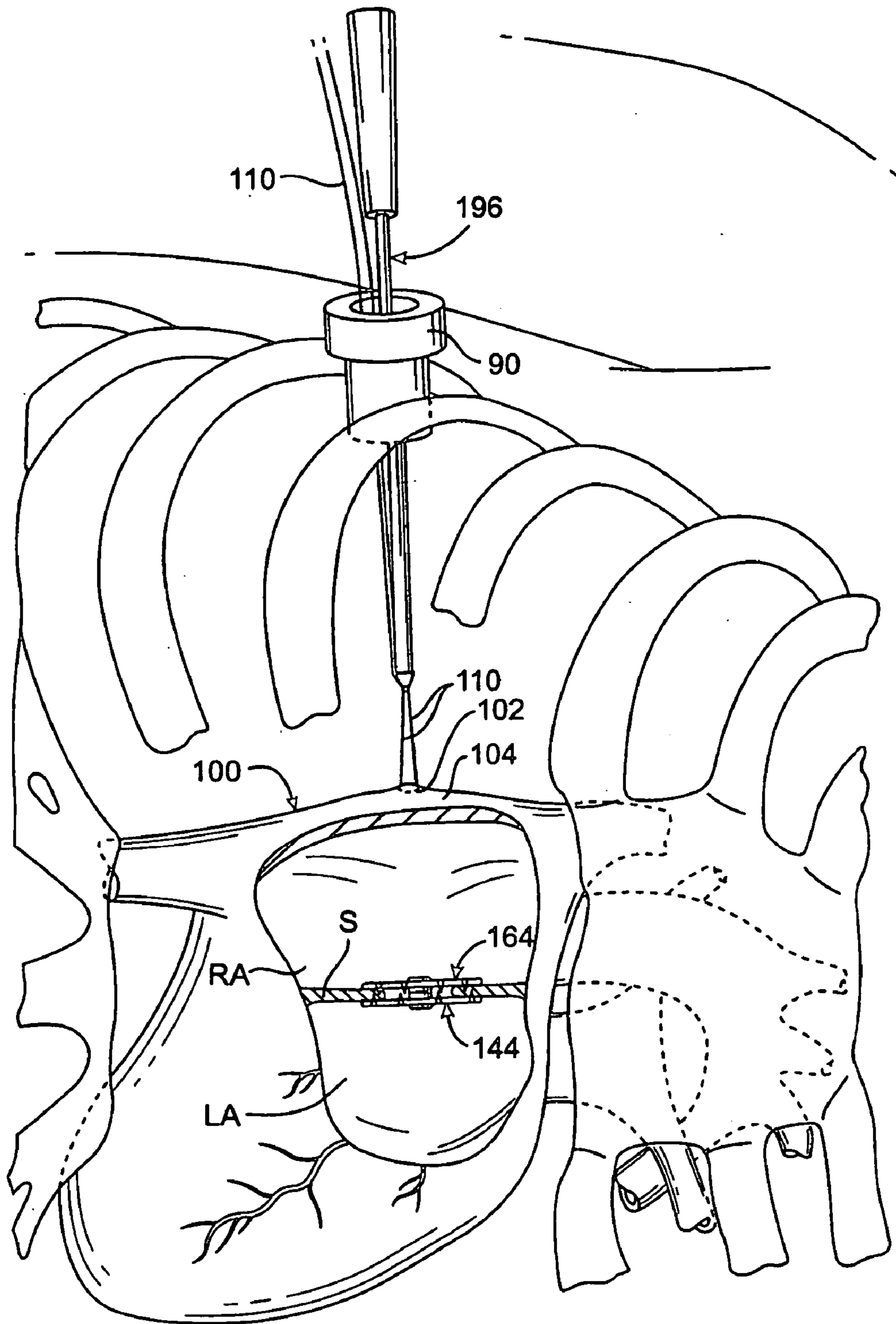
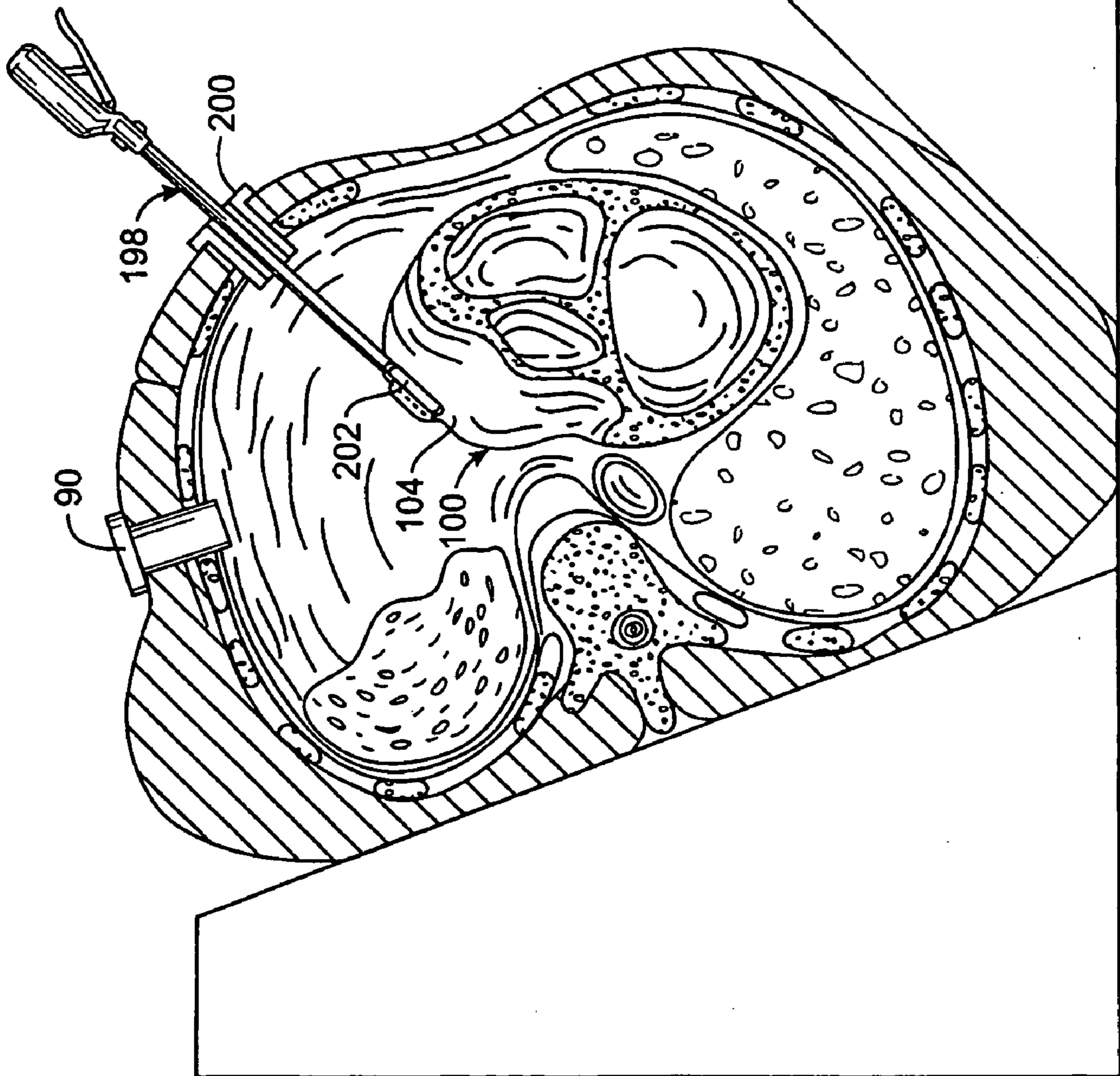

FIG. 19

FIG. 20



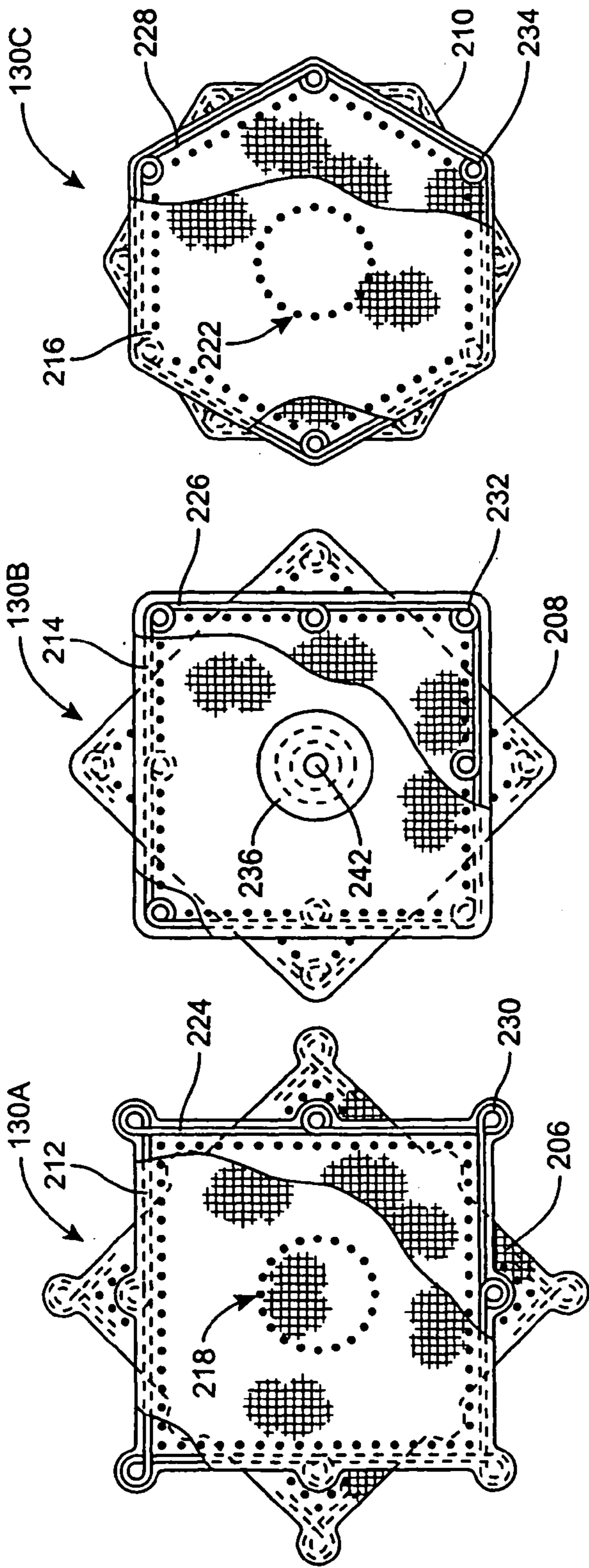

FIG. 21A

FIG. 22A

FIG. 23

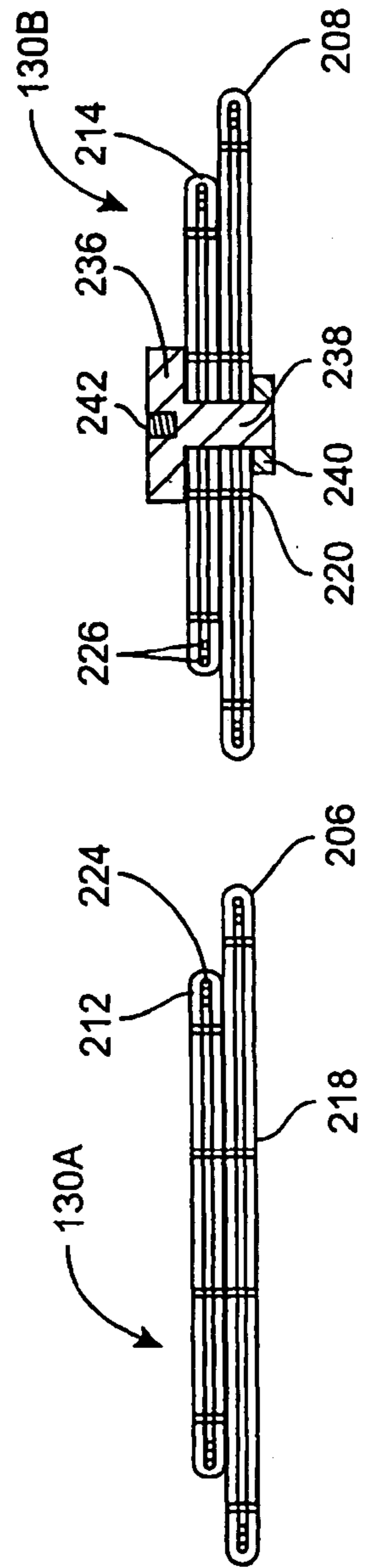

FIG. 21B

FIG. 22B

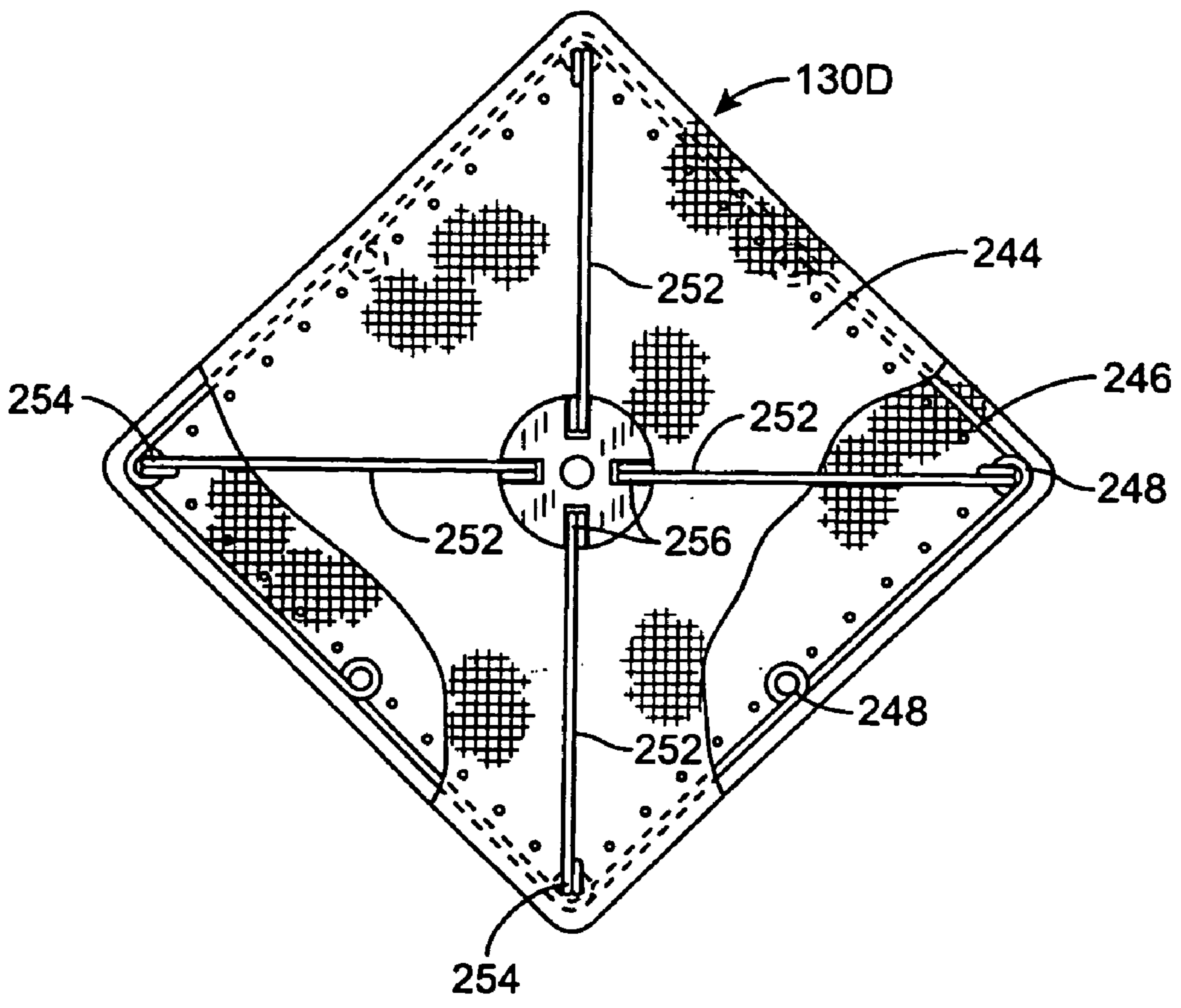

FIG. 24A

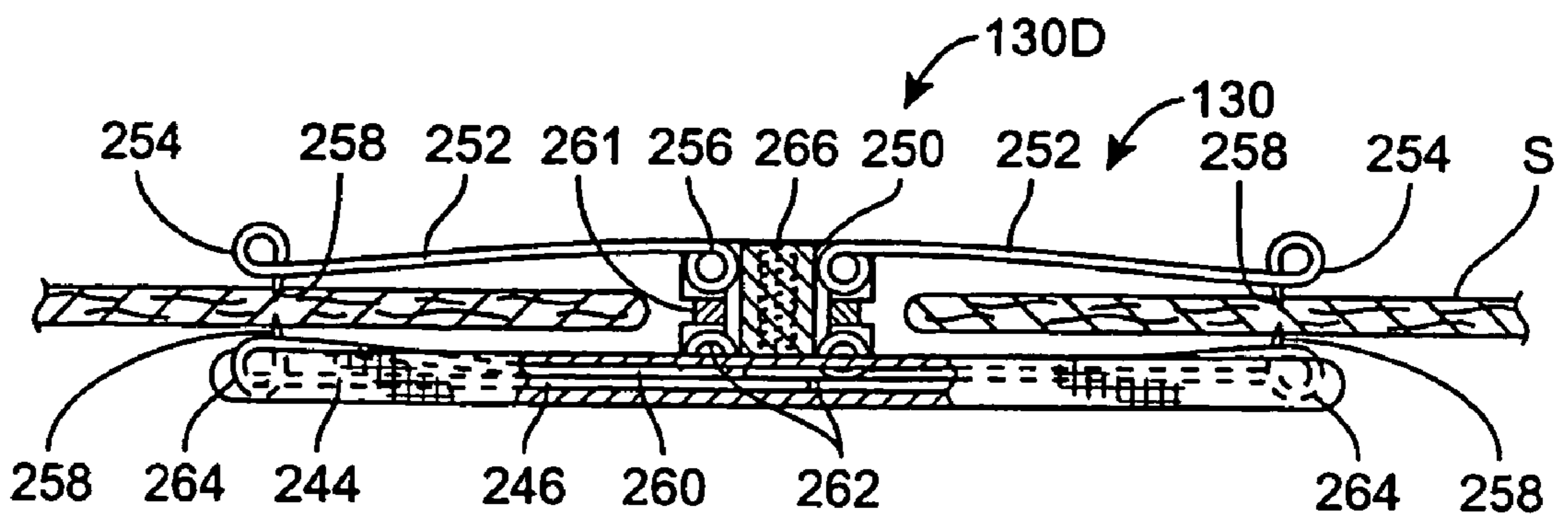

FIG. 24B

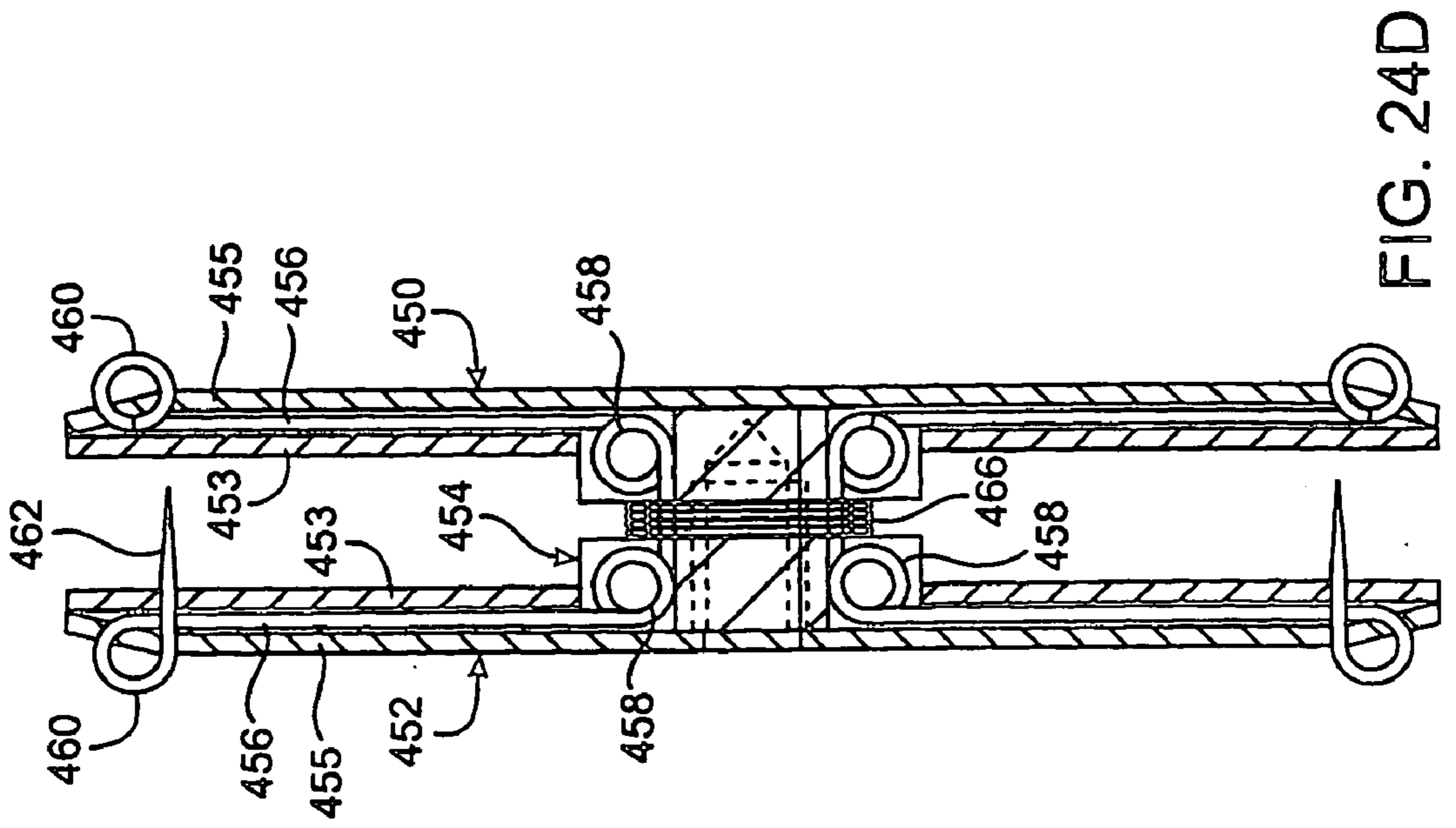

FIG. 24D

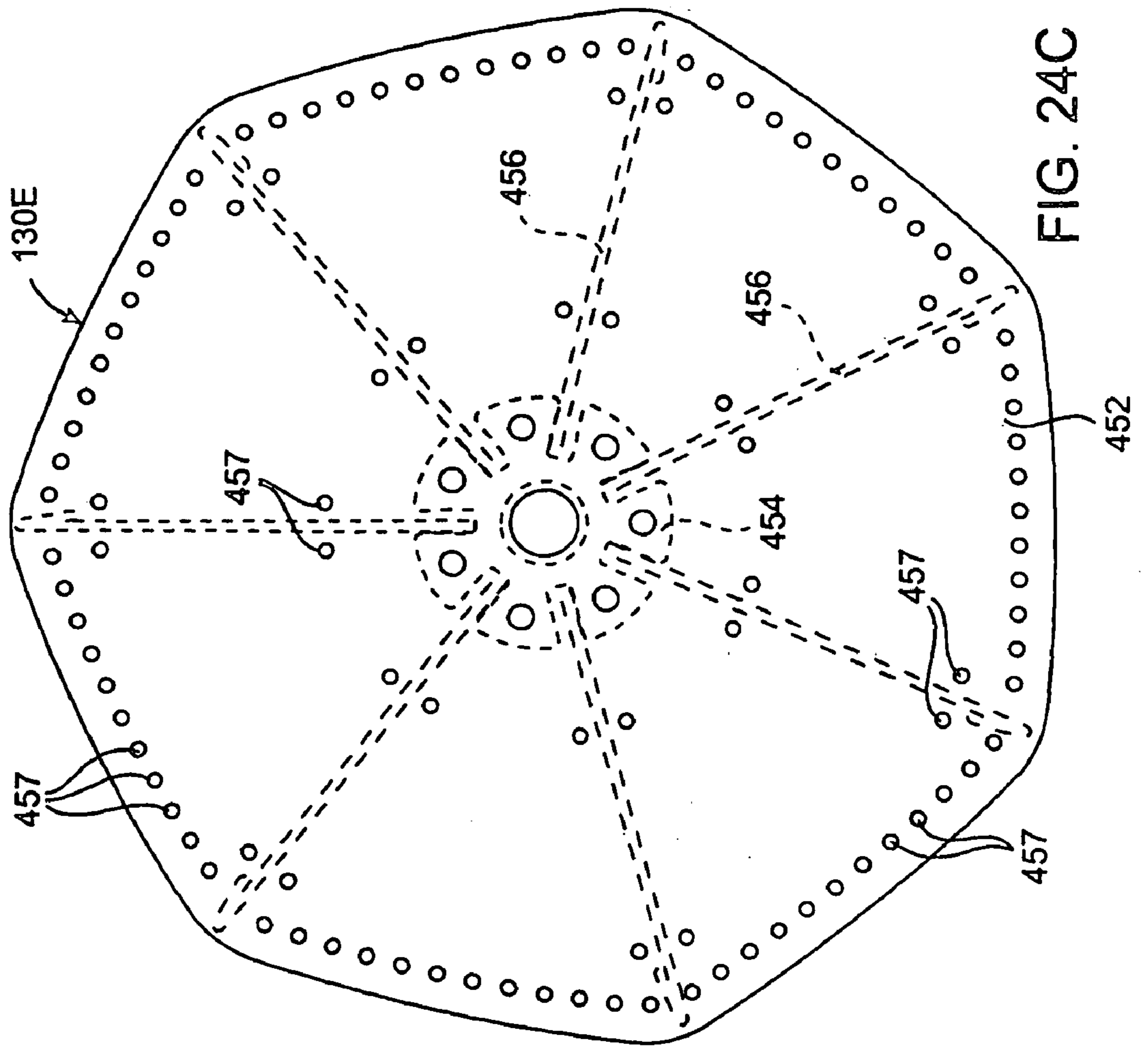
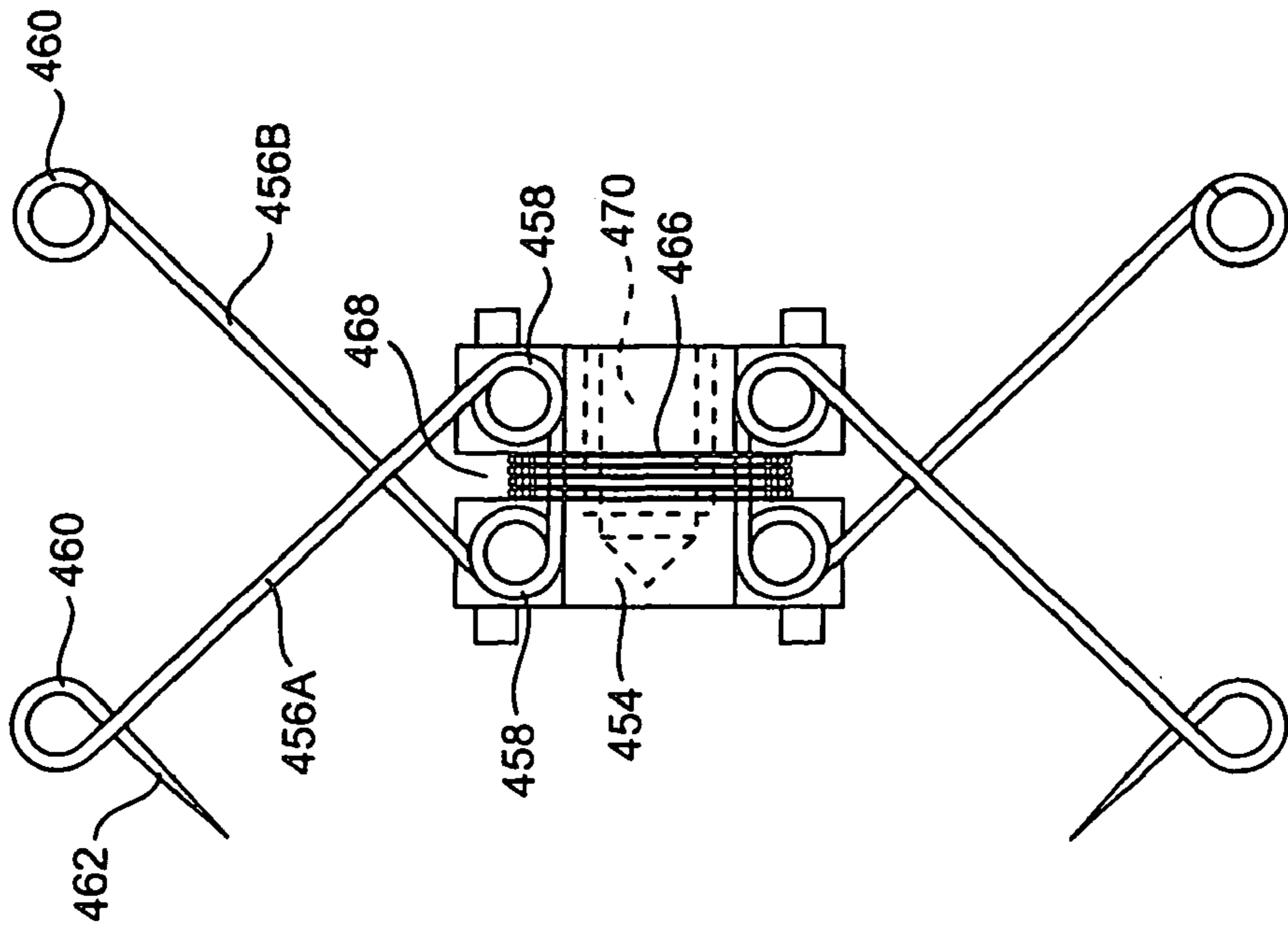
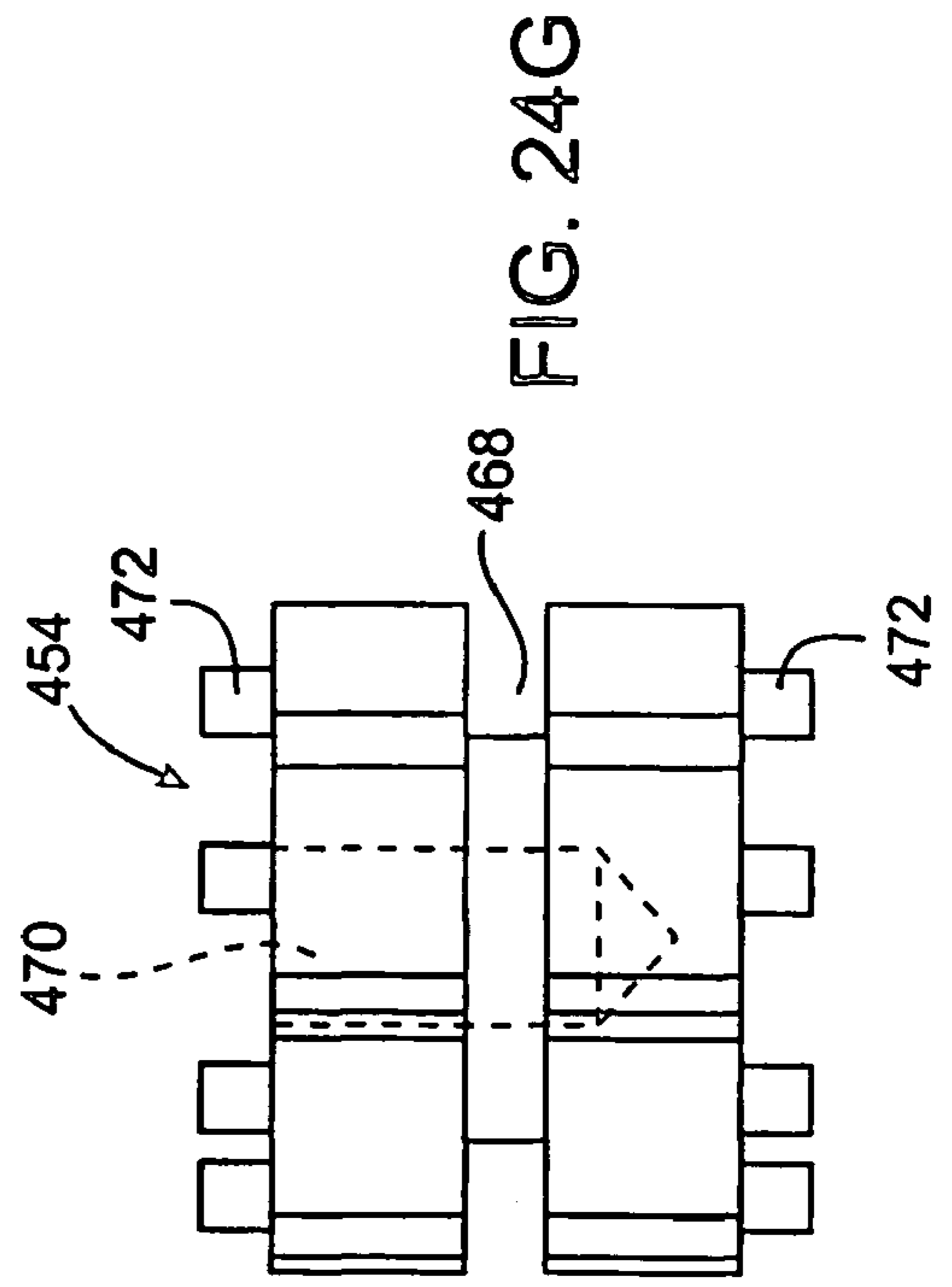
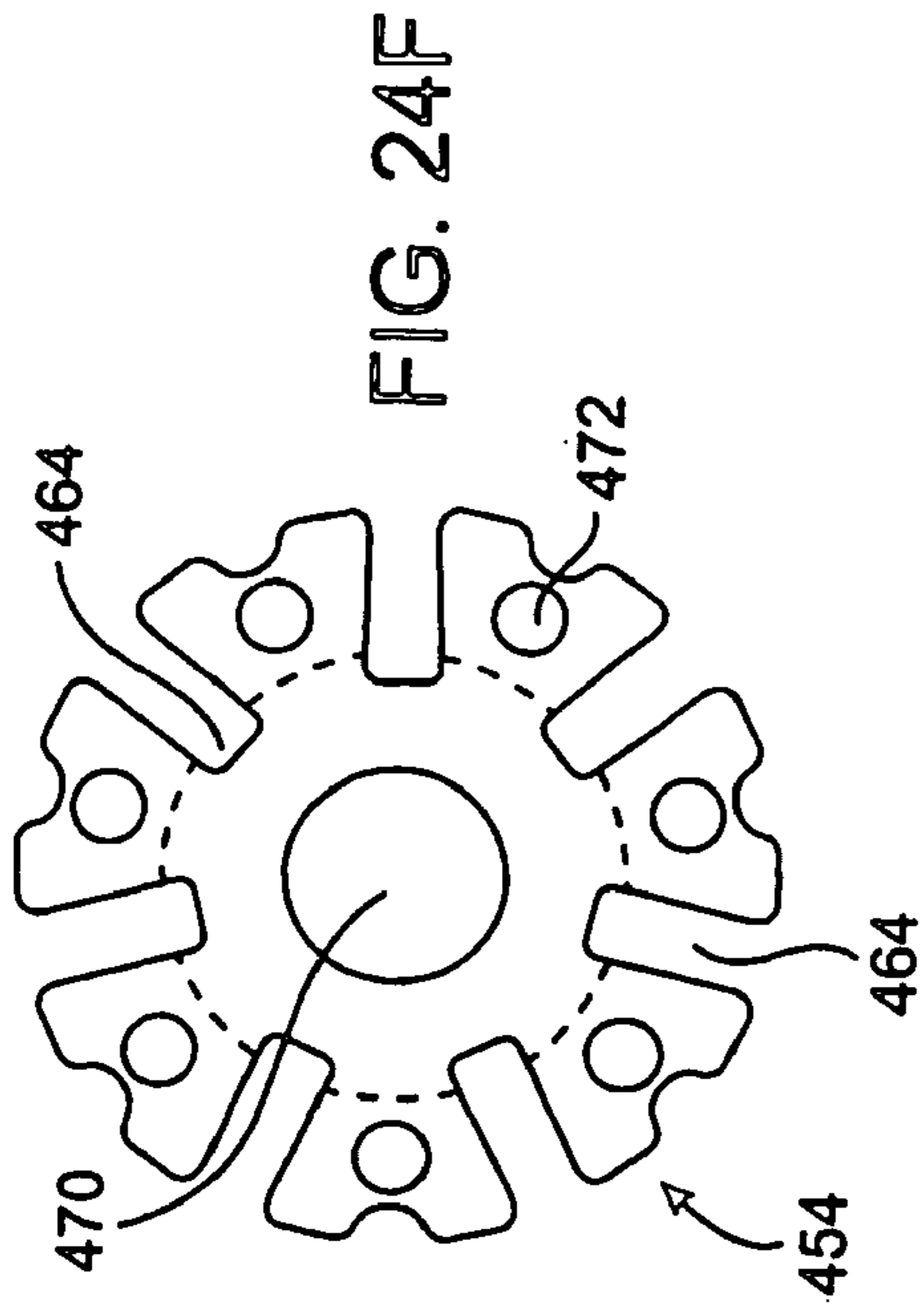

FIG. 24C



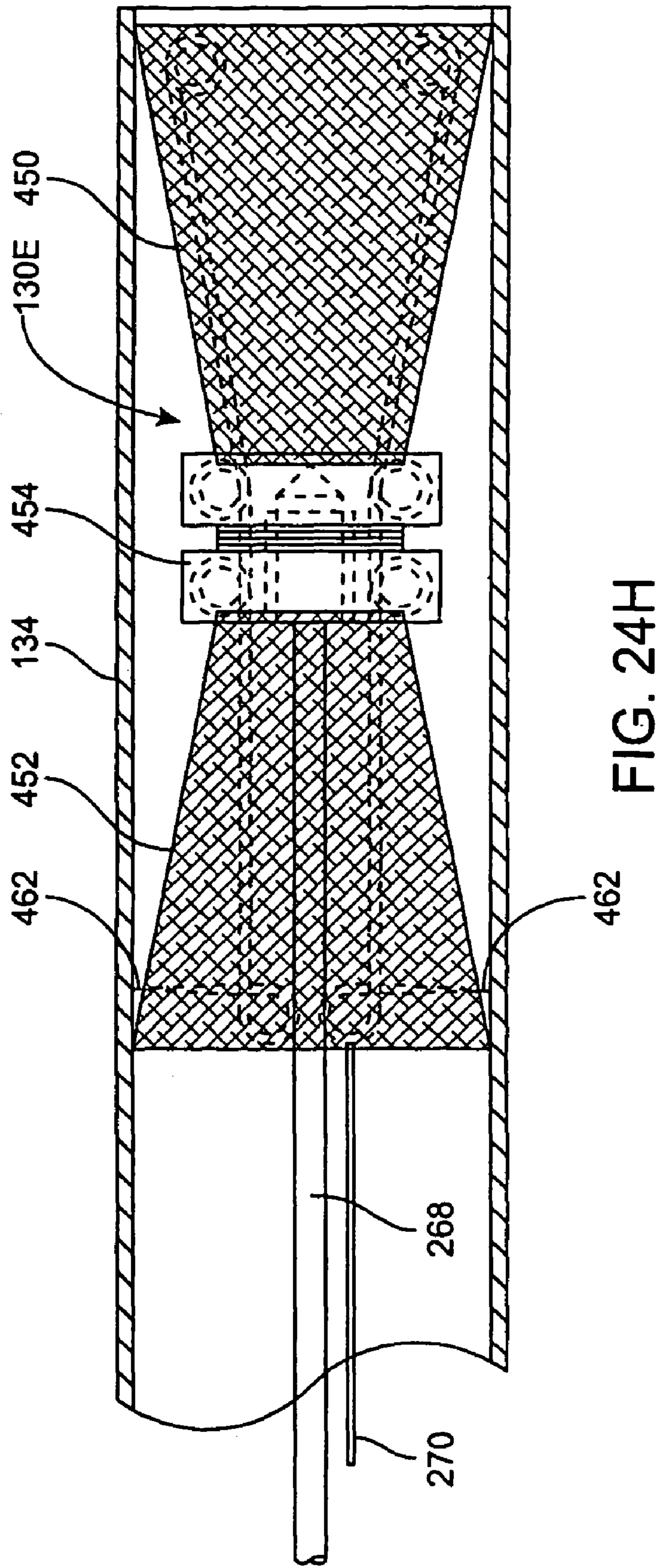

FIG. 24H

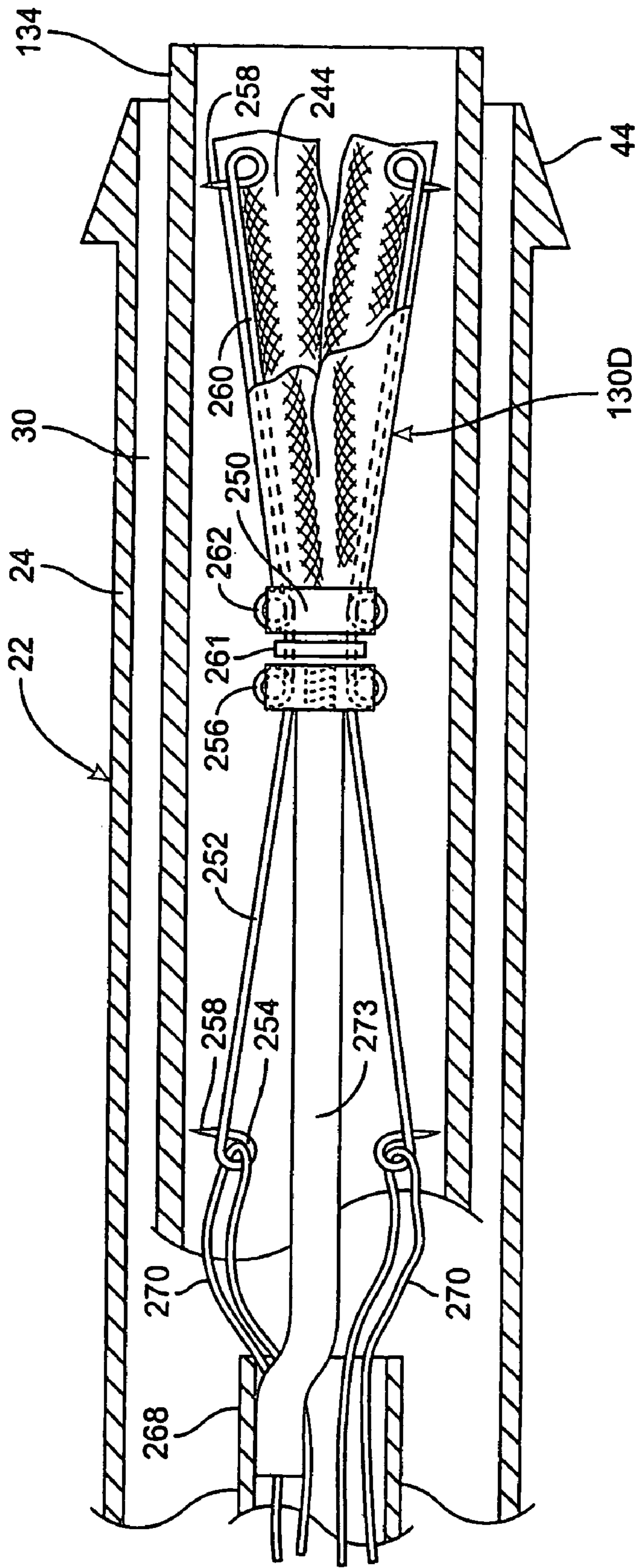
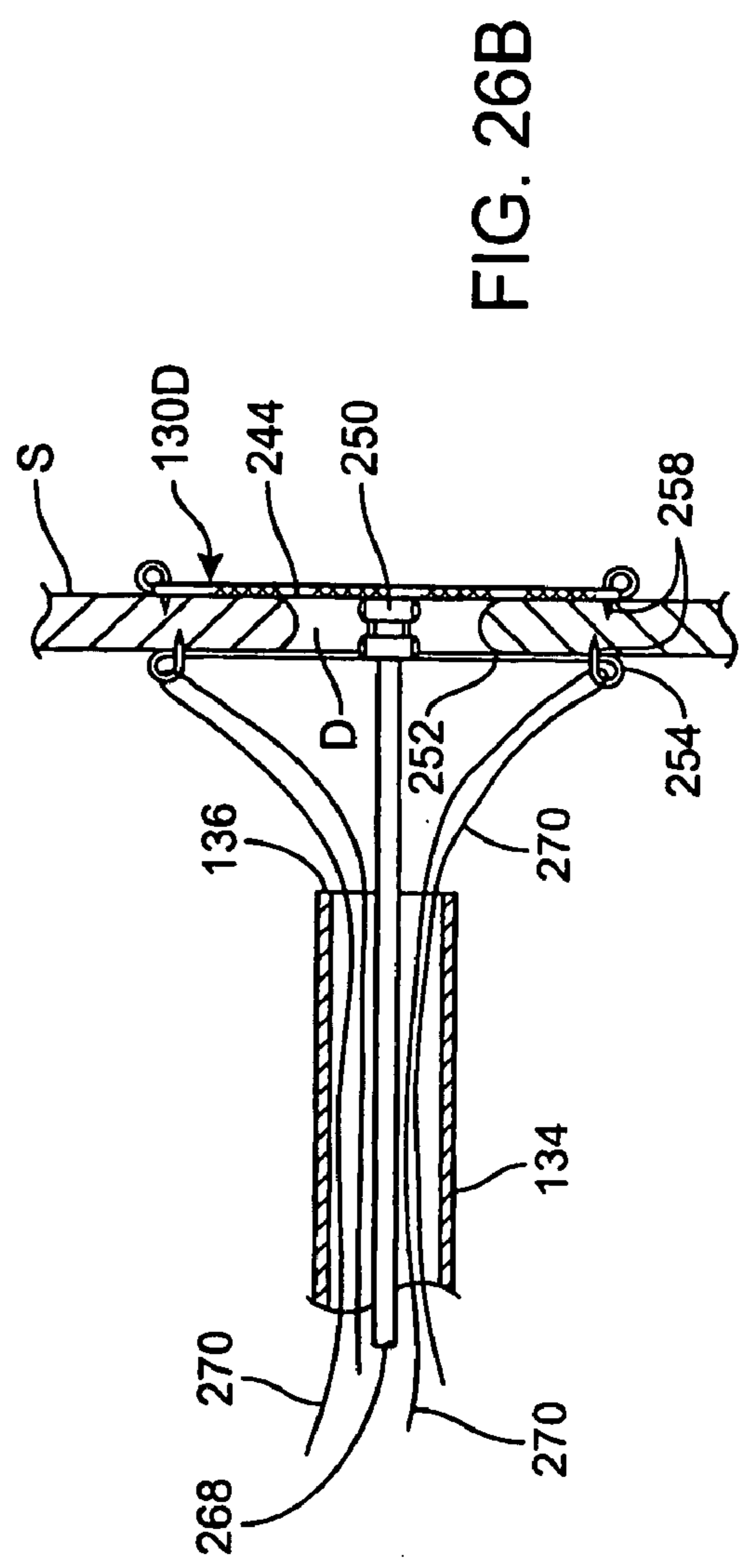
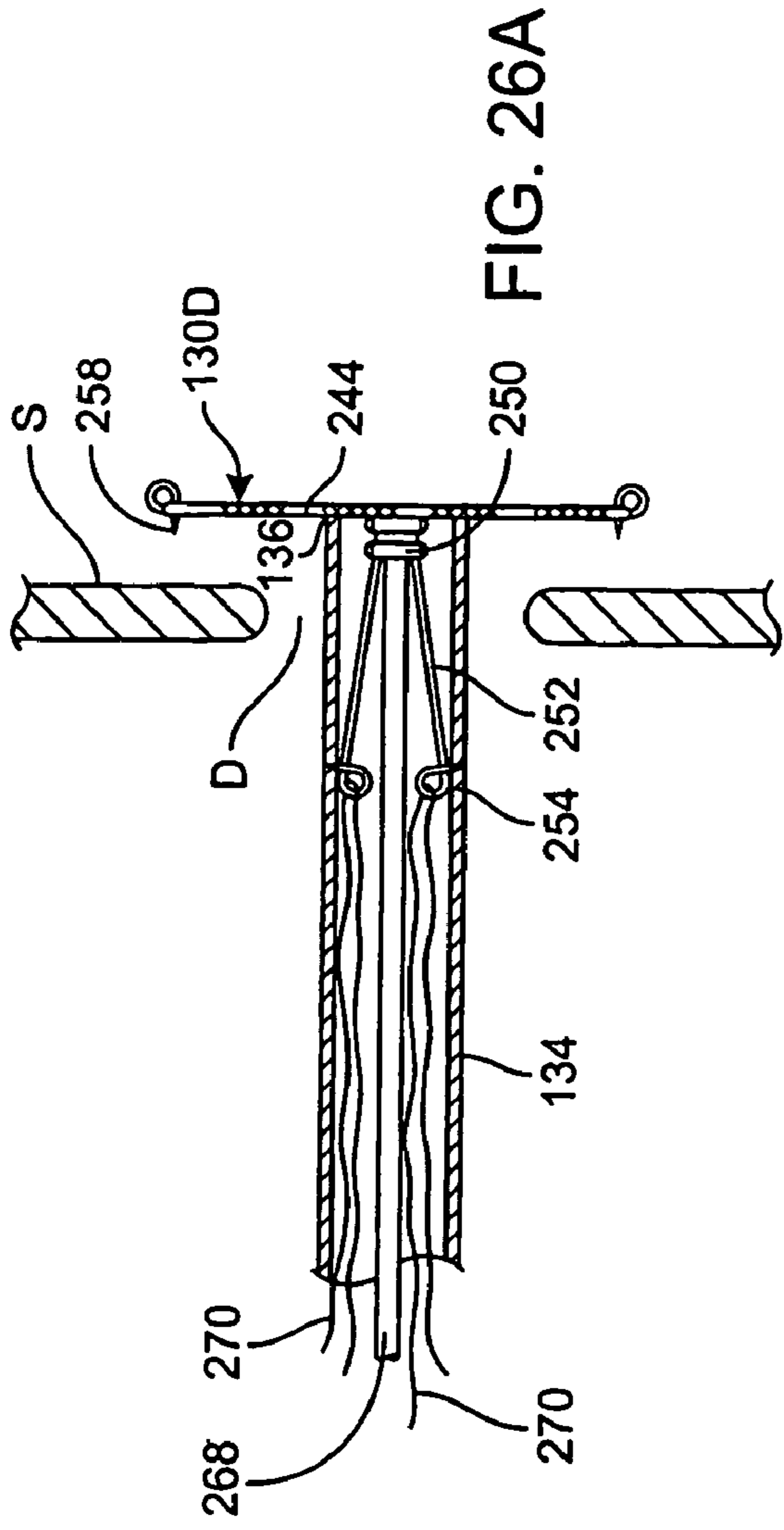

FIG. 25A



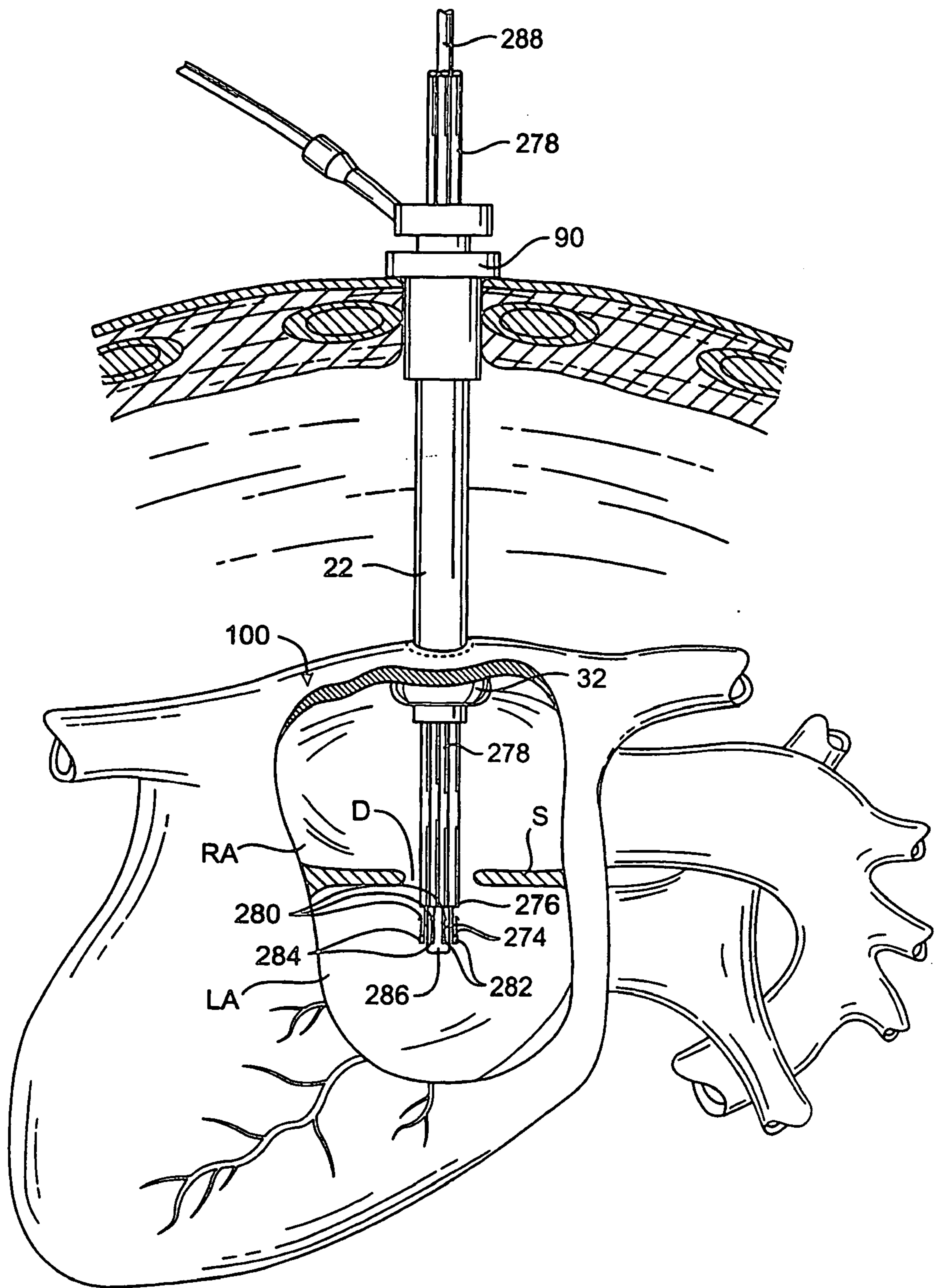

FIG. 27

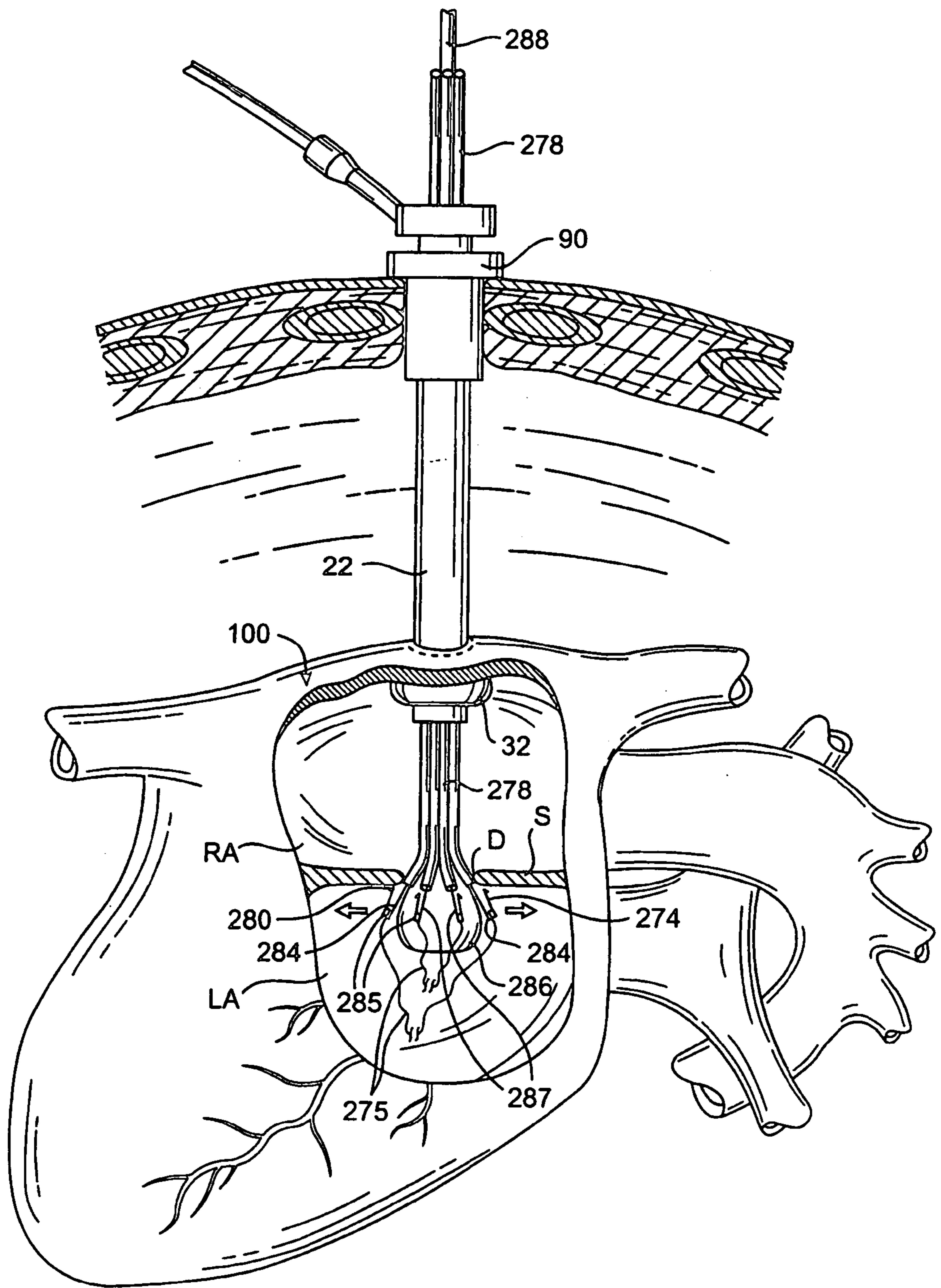

FIG. 28

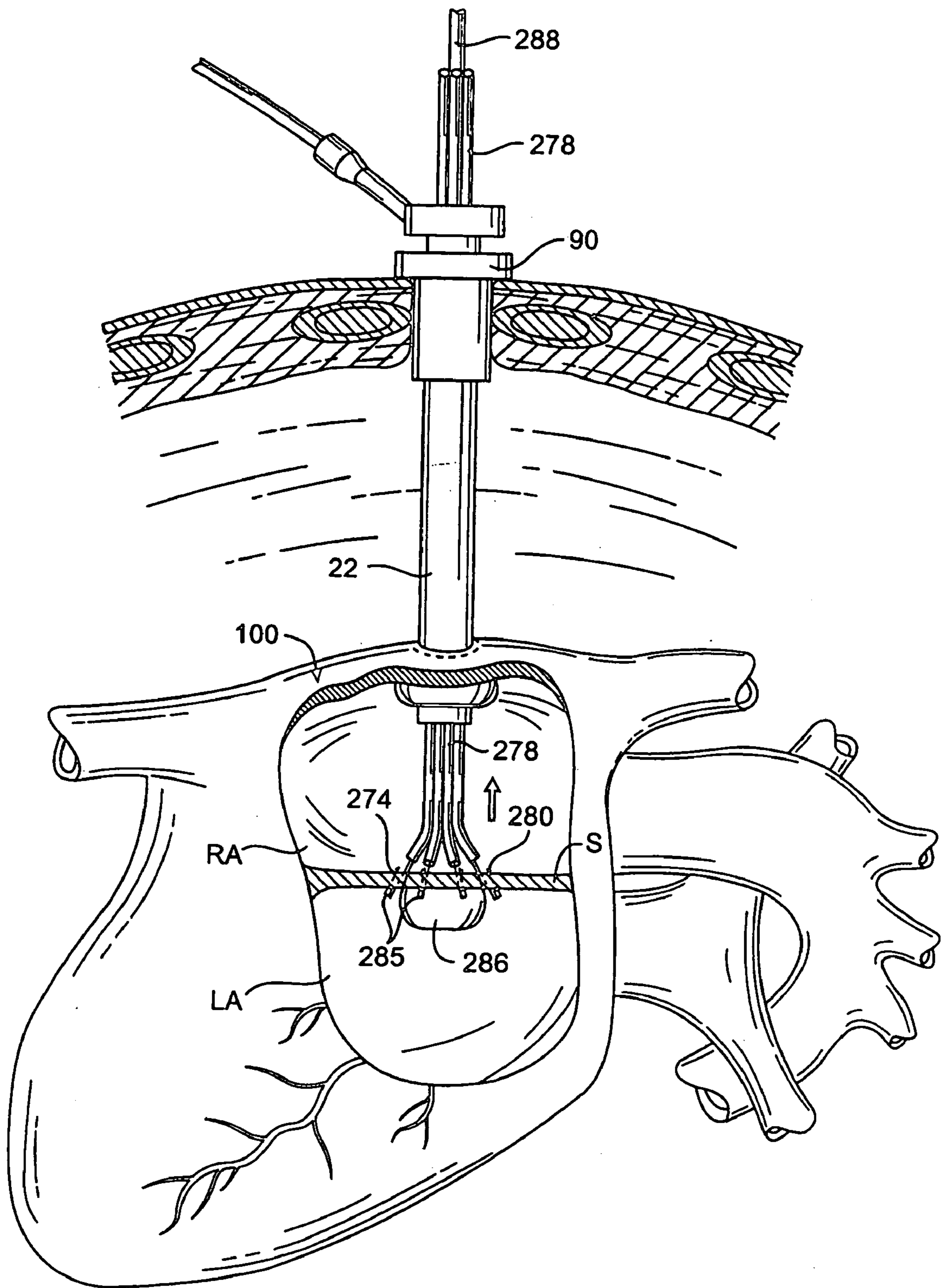

FIG. 29A

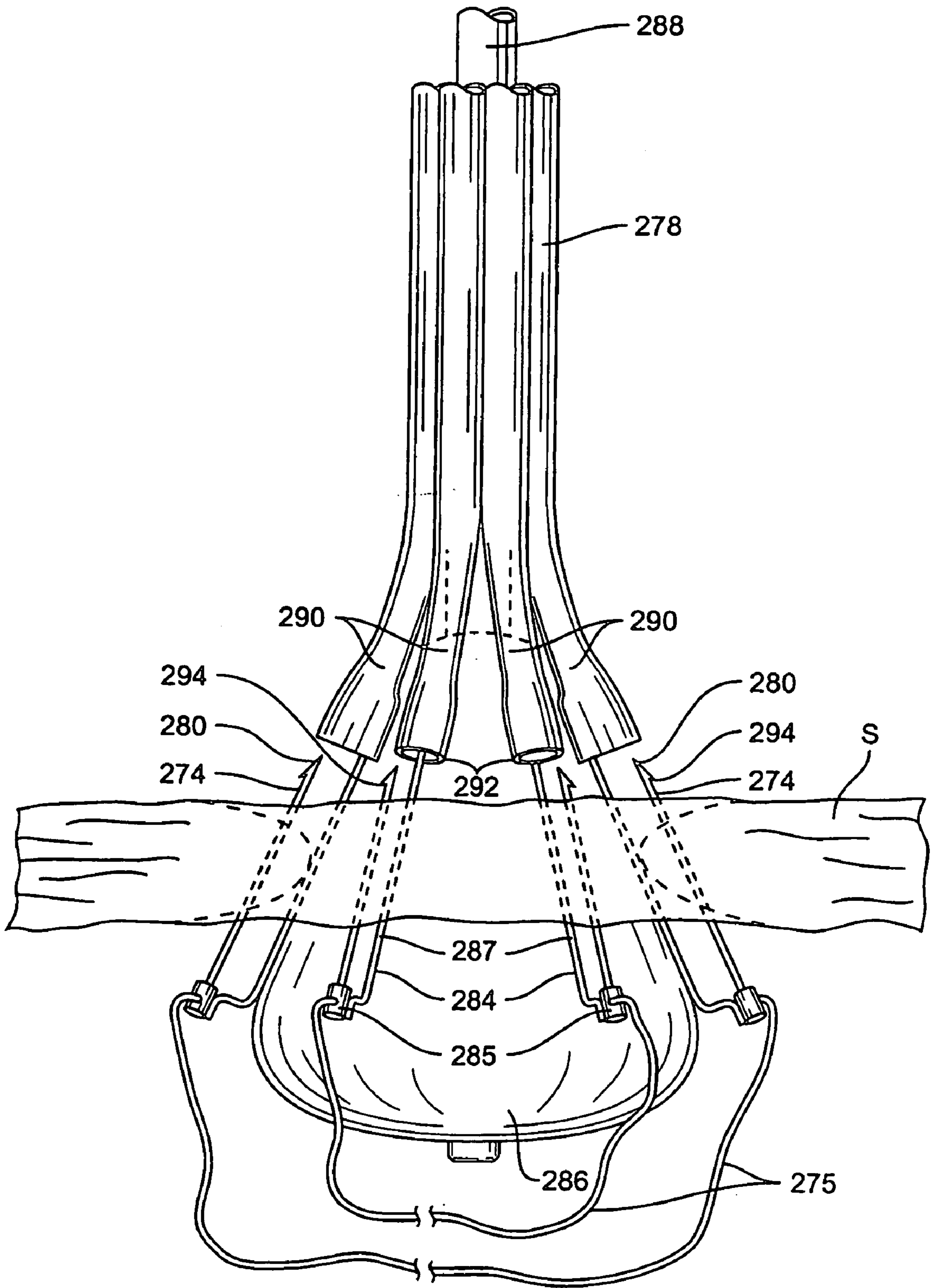

FIG. 29B

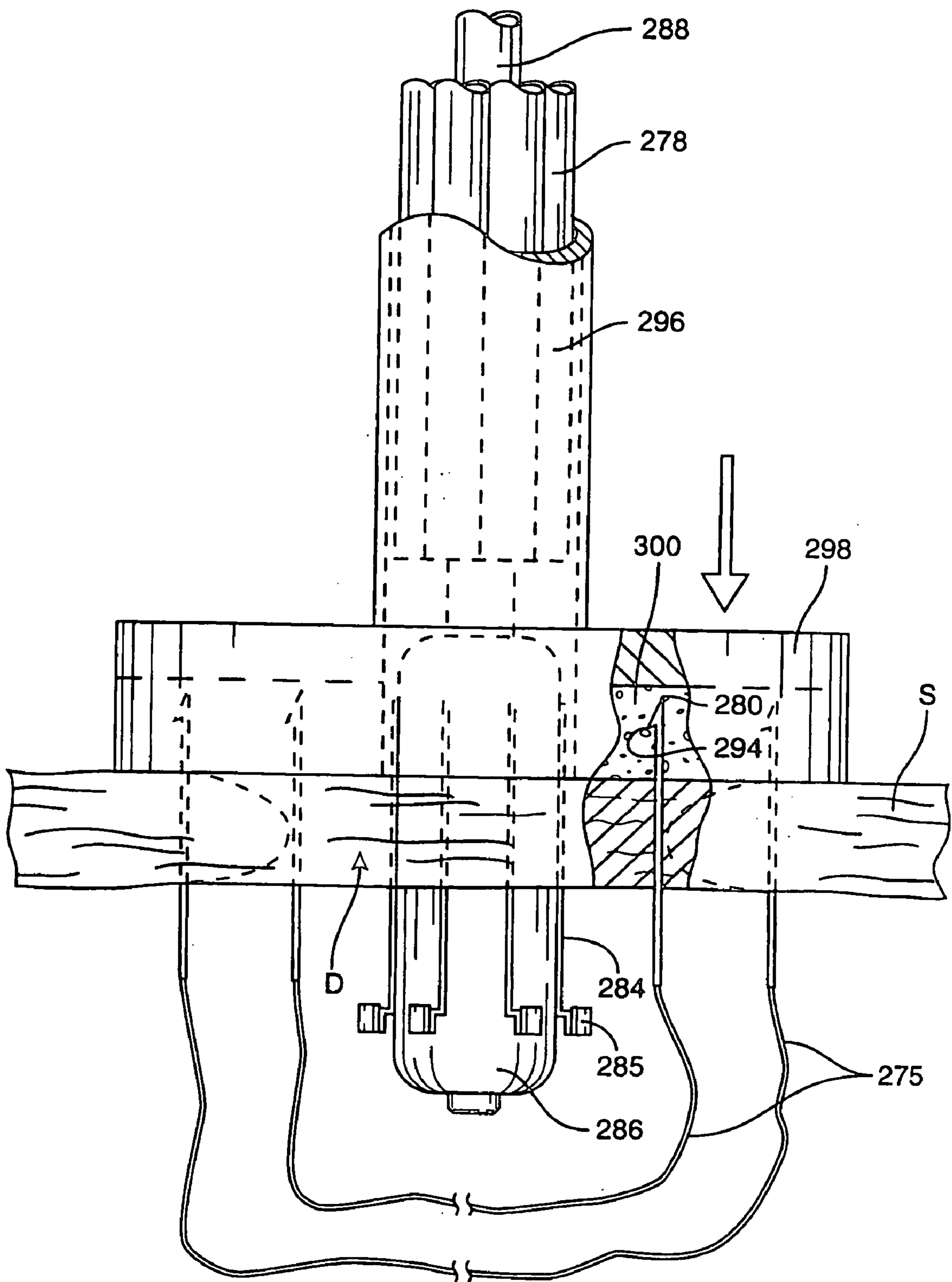

FIG. 30A

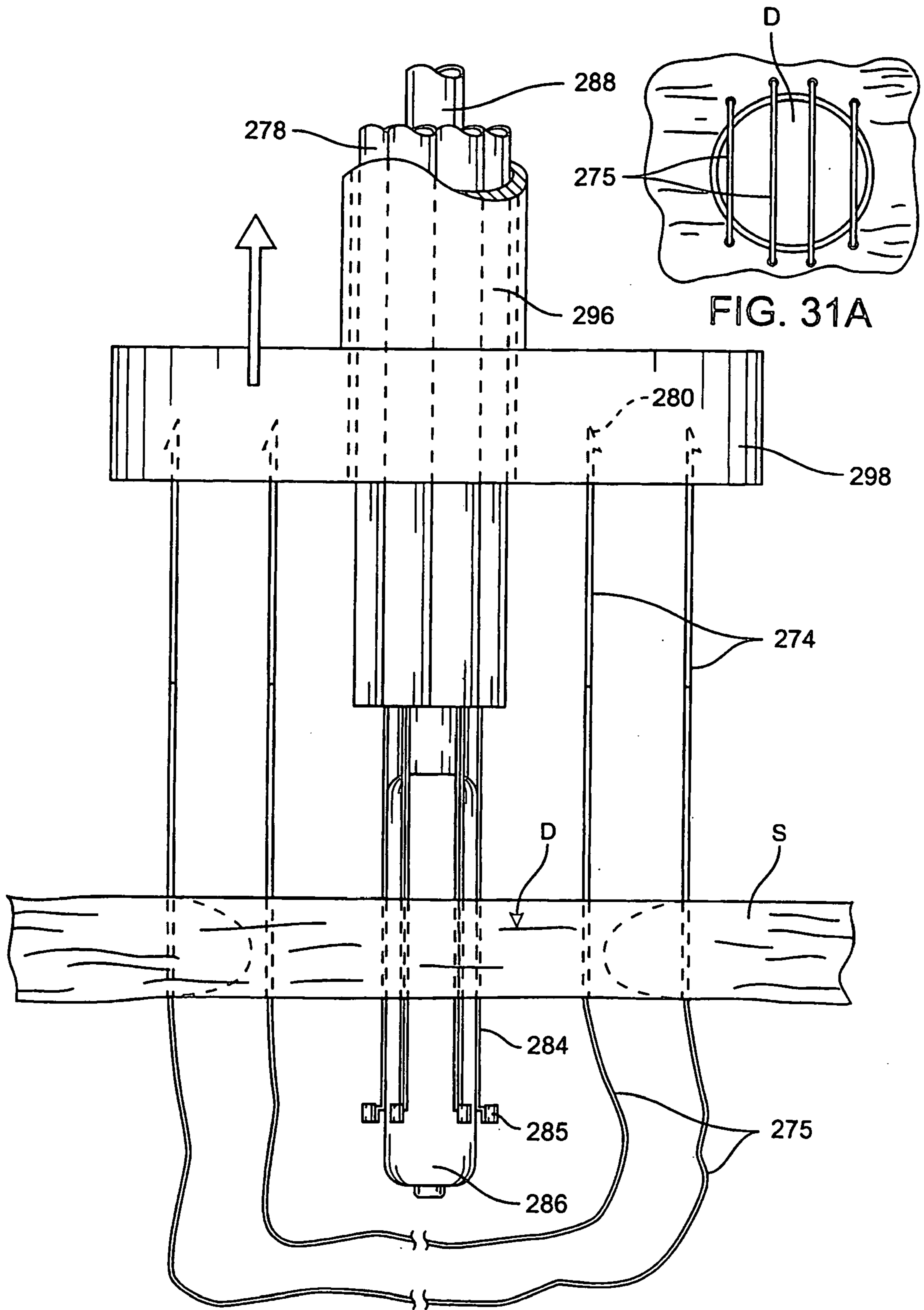

FIG. 30B

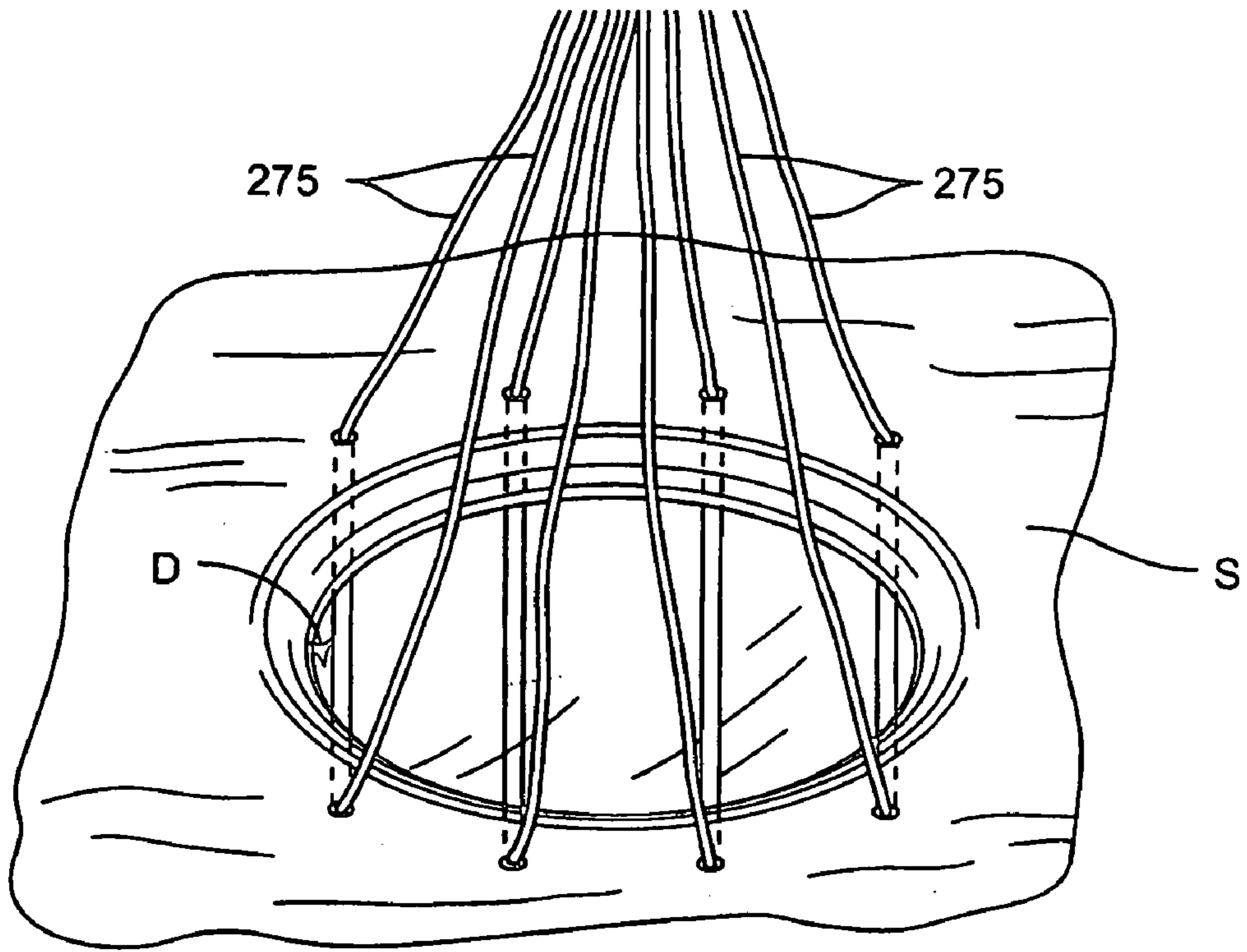

FIG. 31B

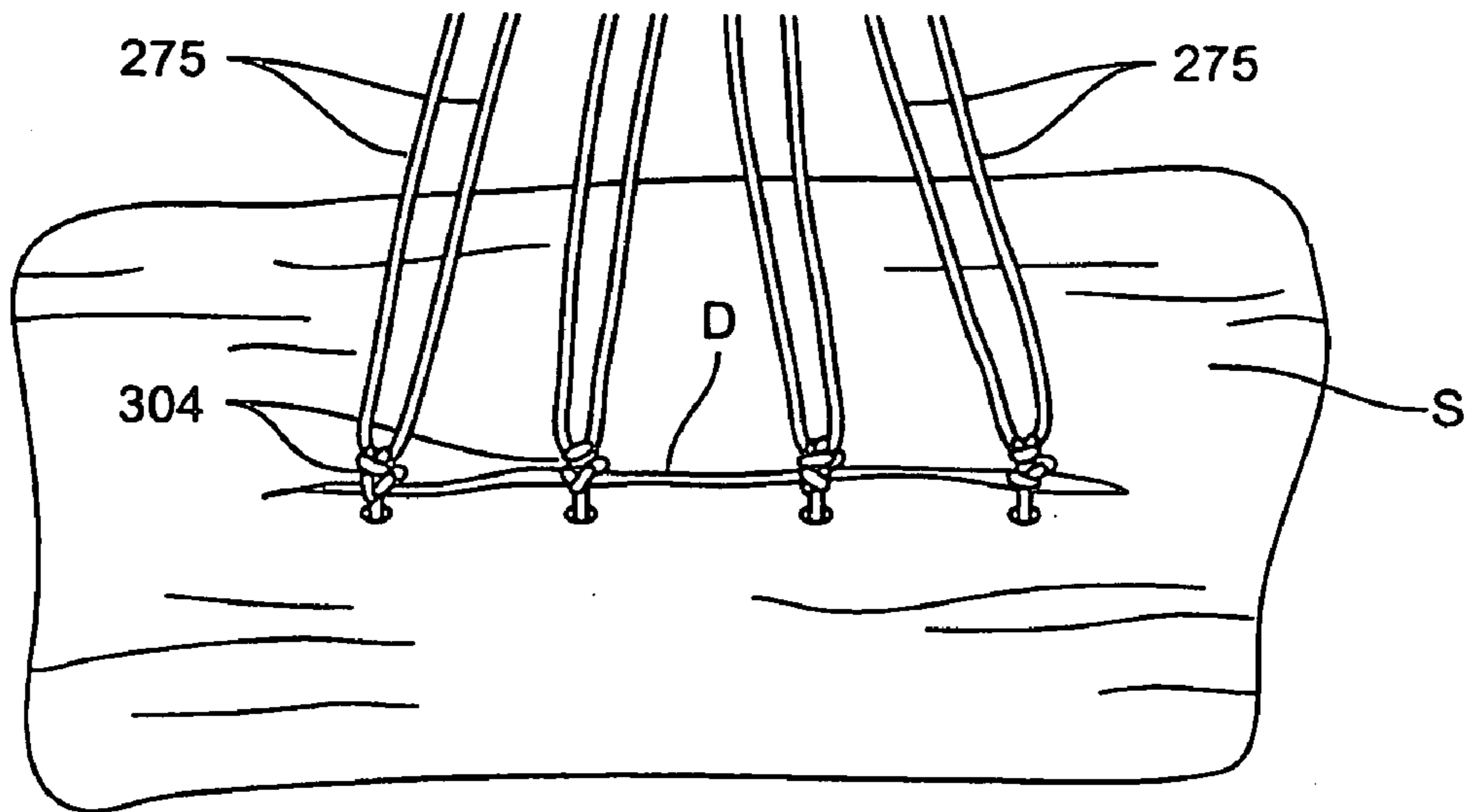

FIG. 31C

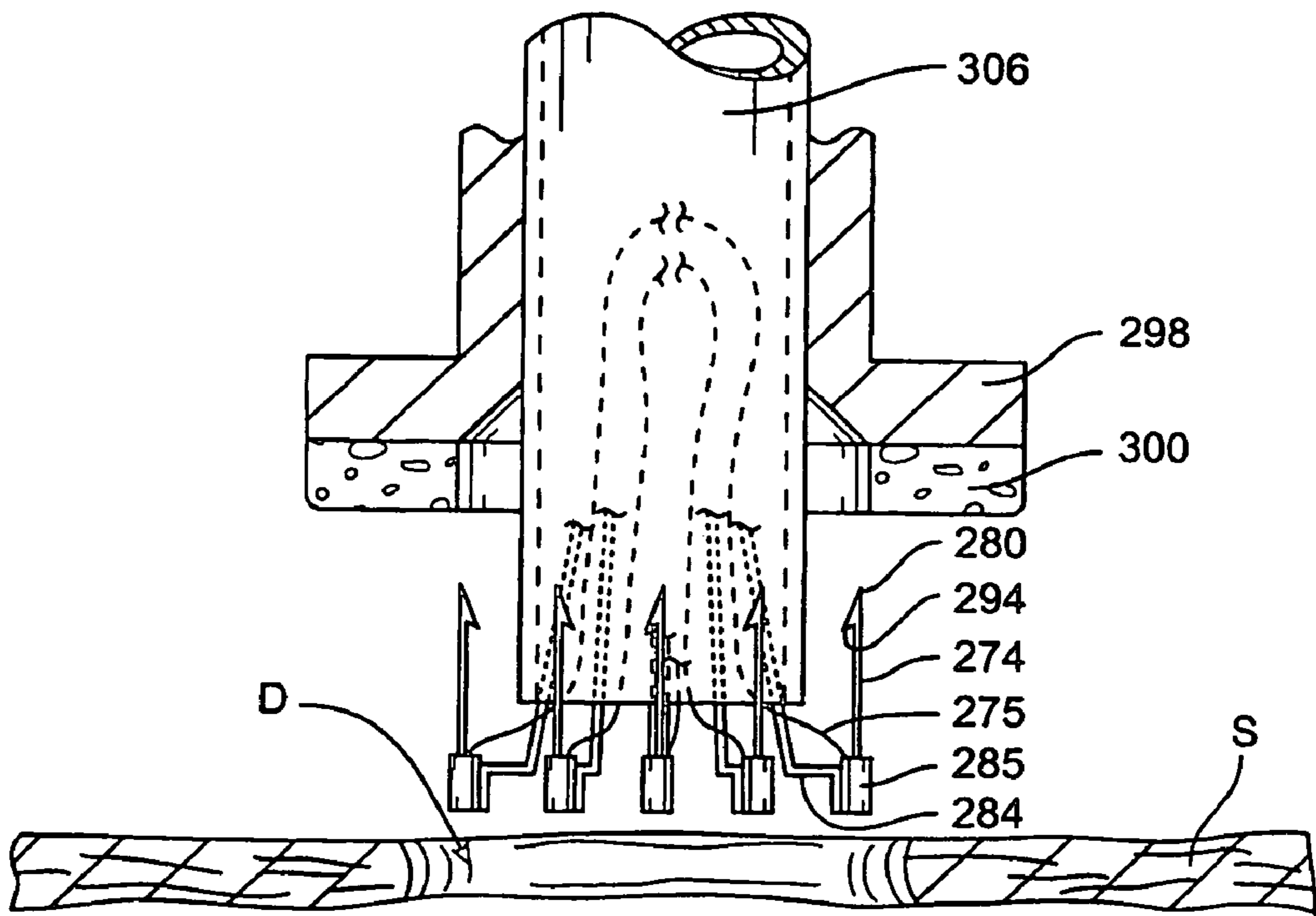

FIG. 32A

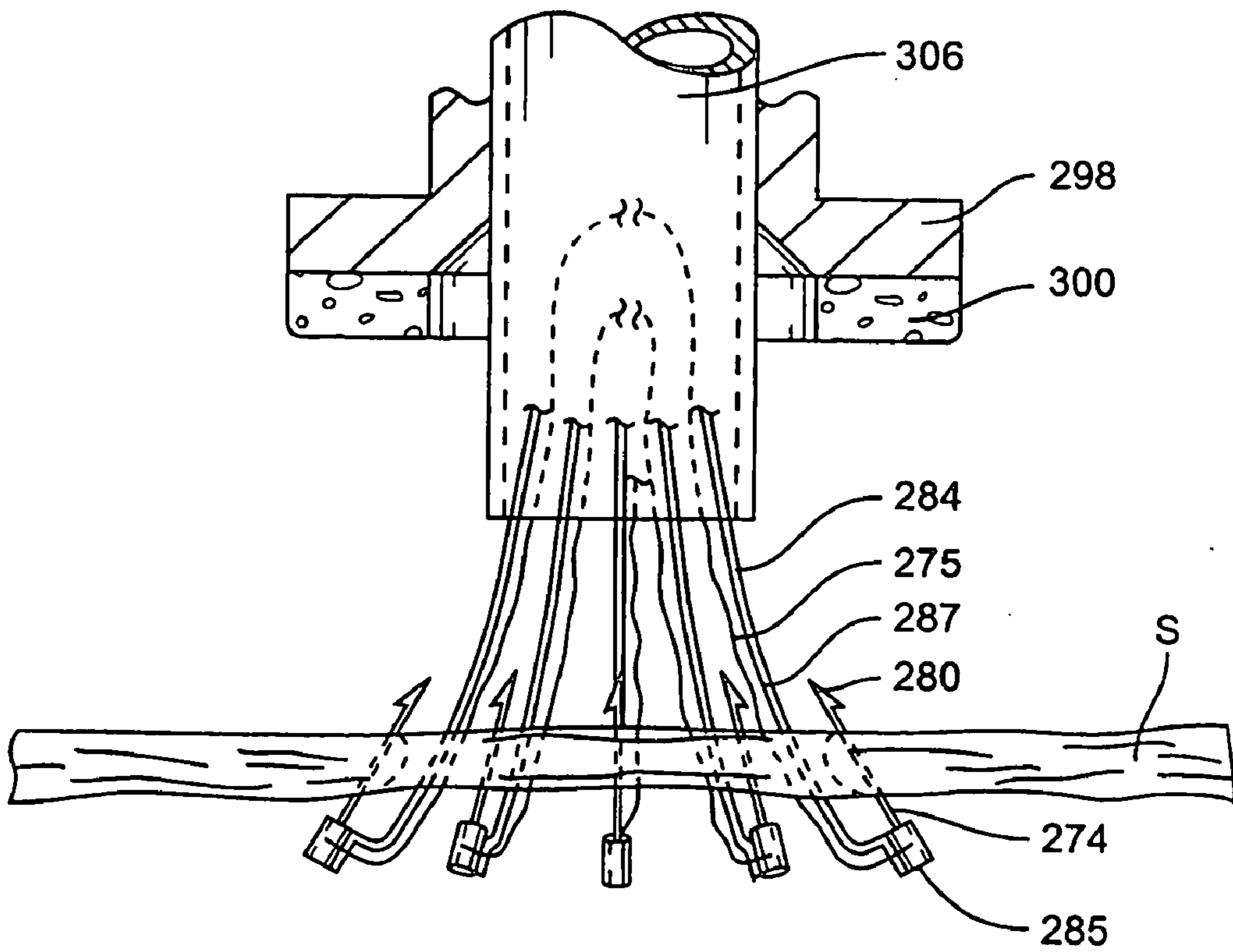

FIG. 32B

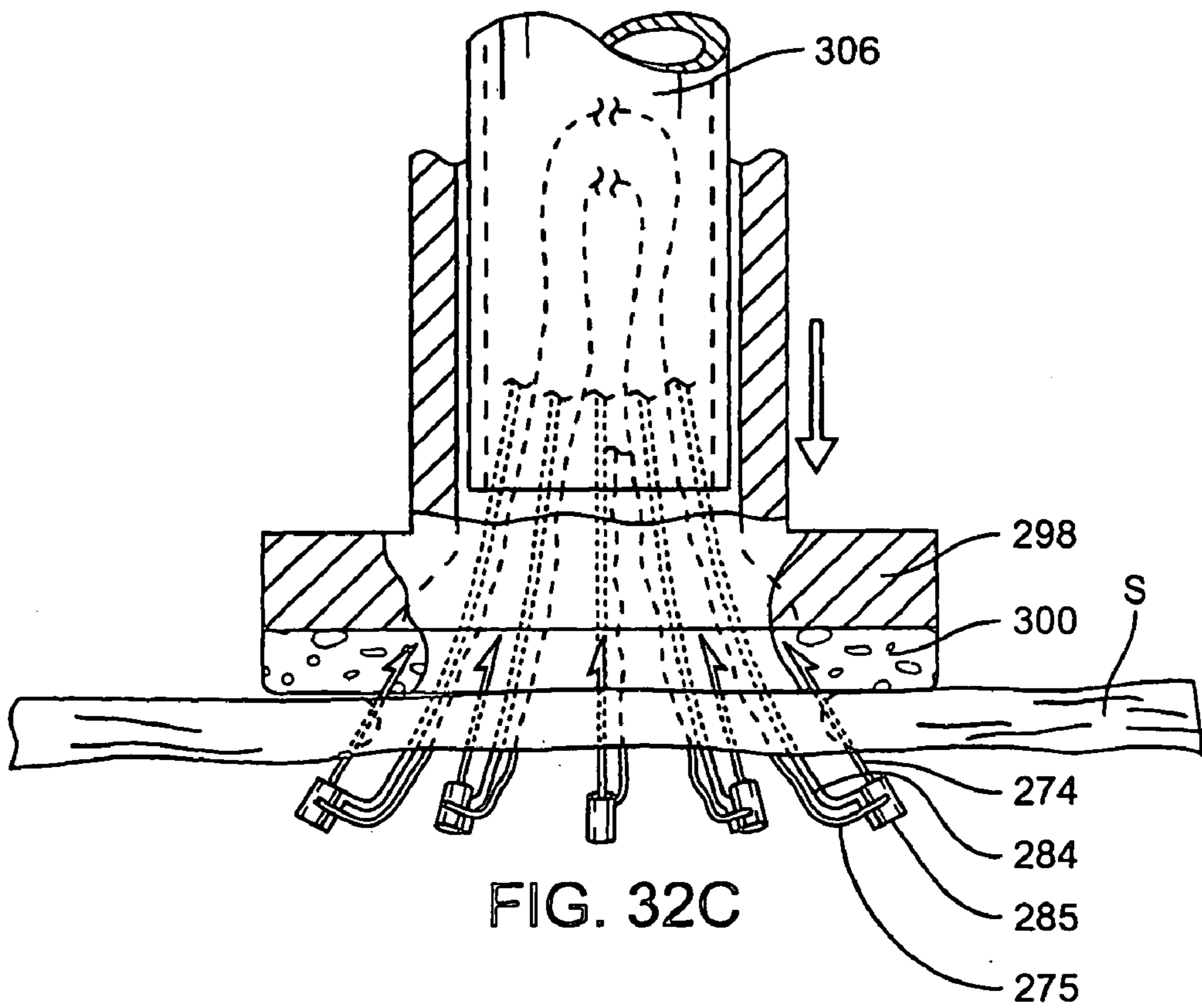

FIG. 32C

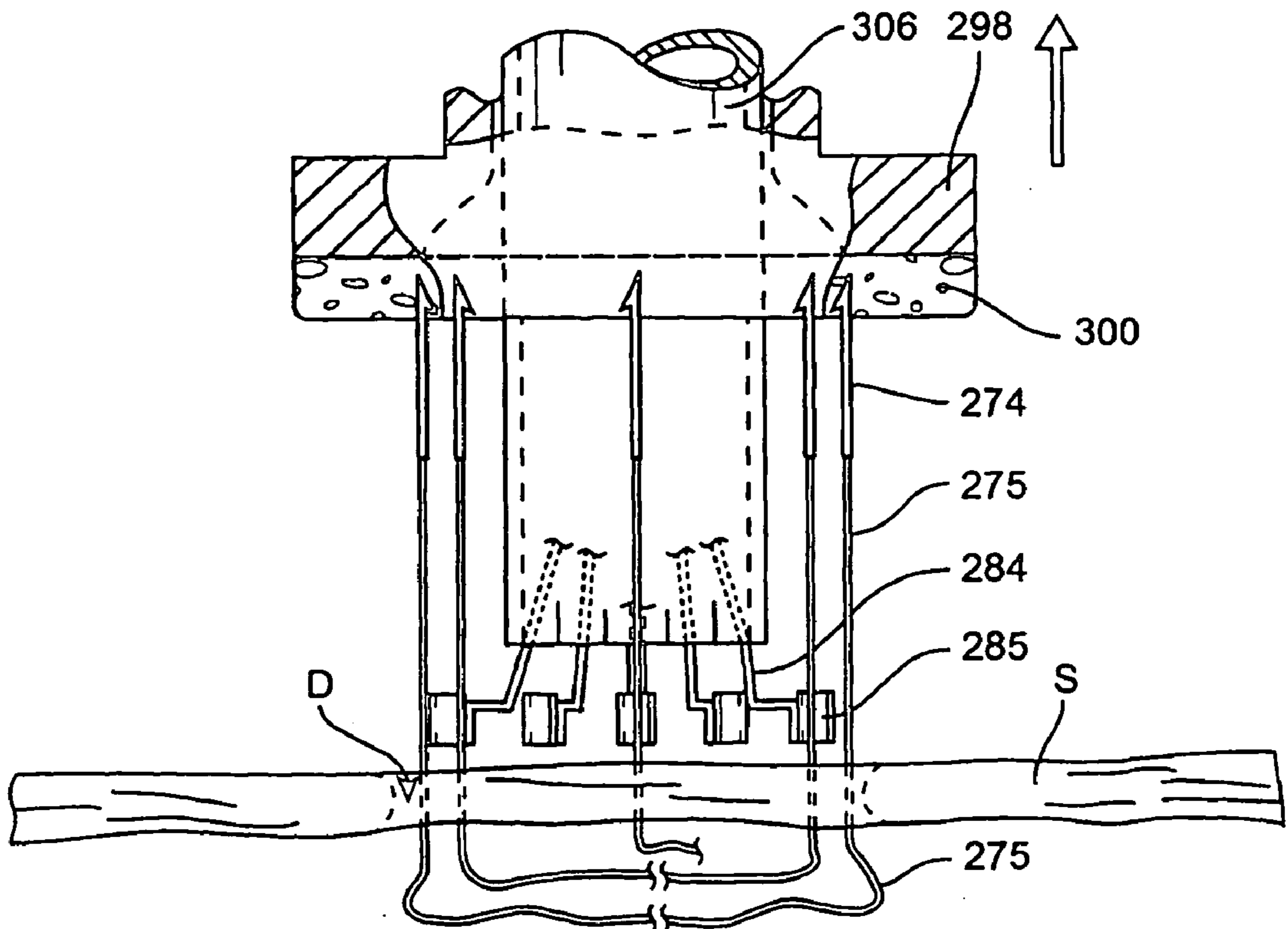
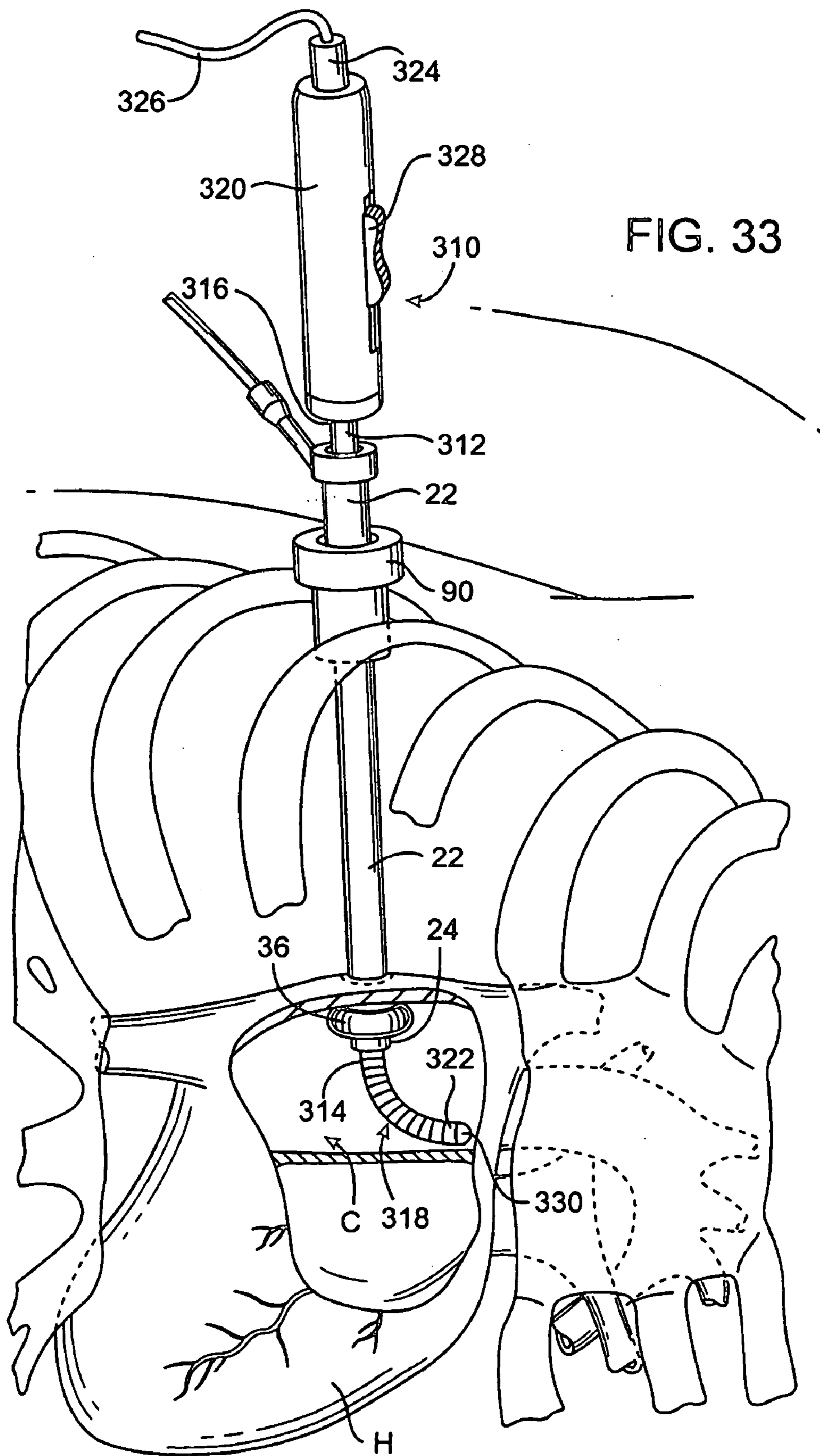
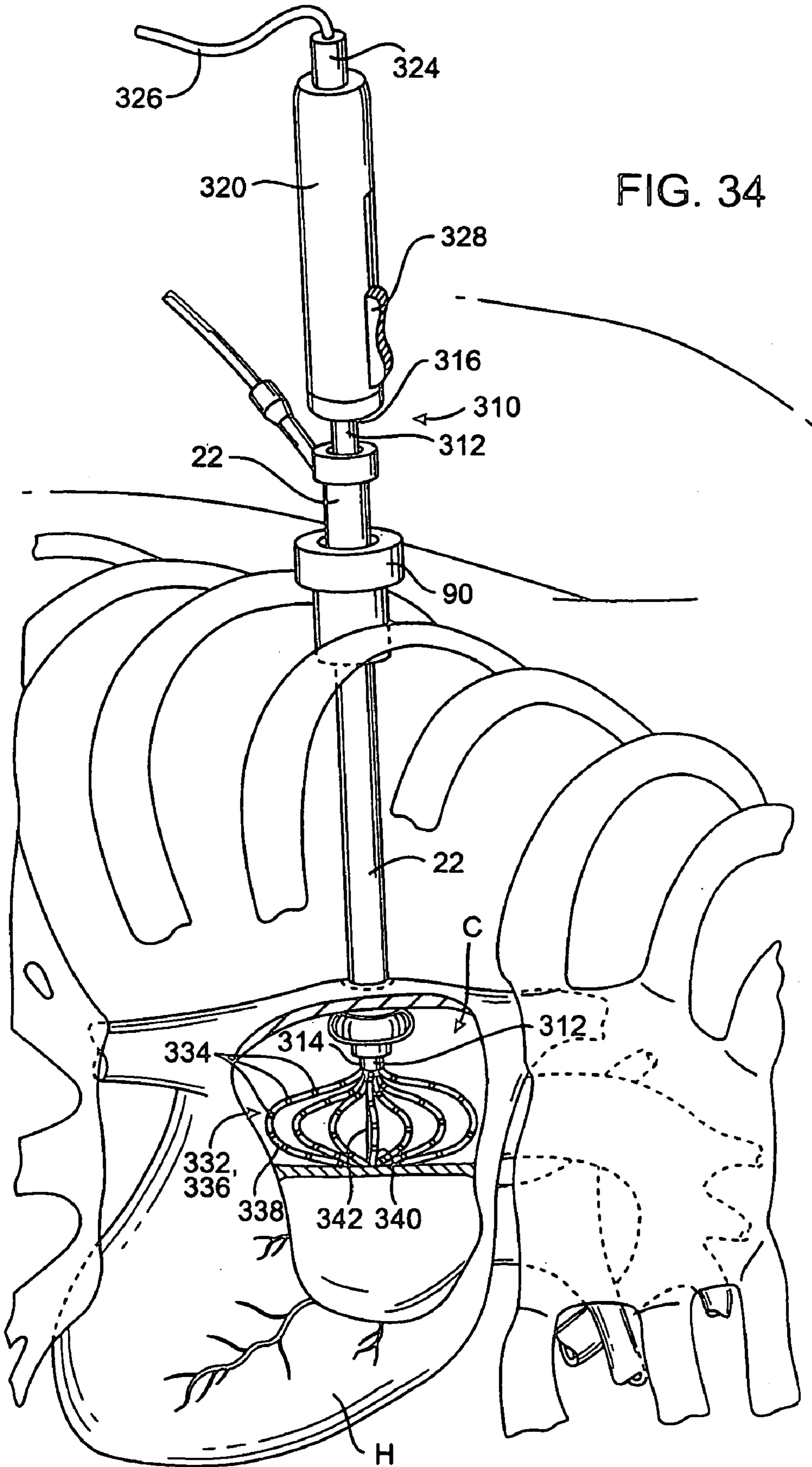

FIG. 32D





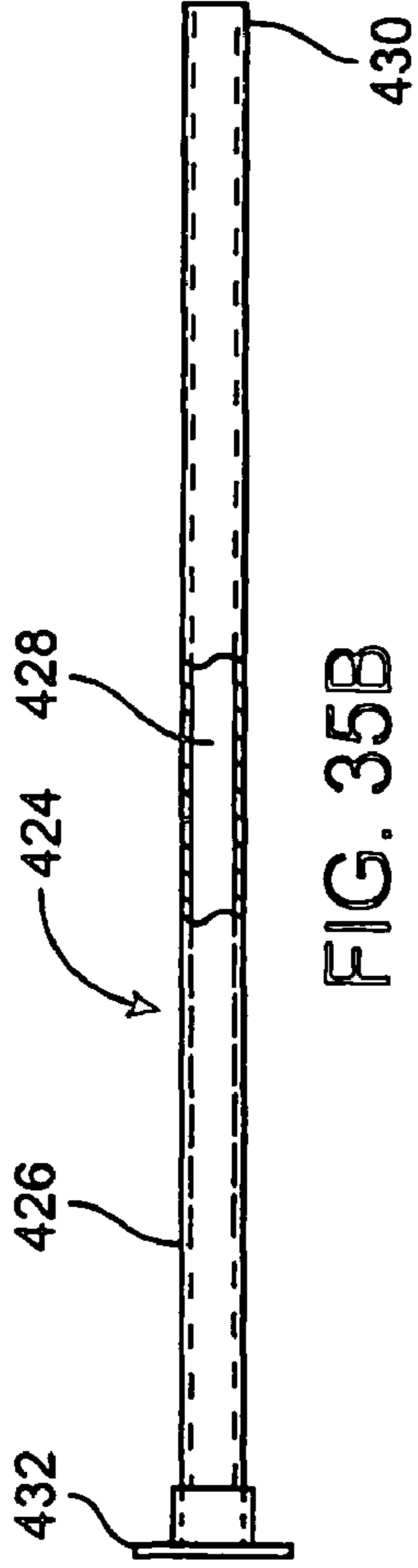

FIG. 35B

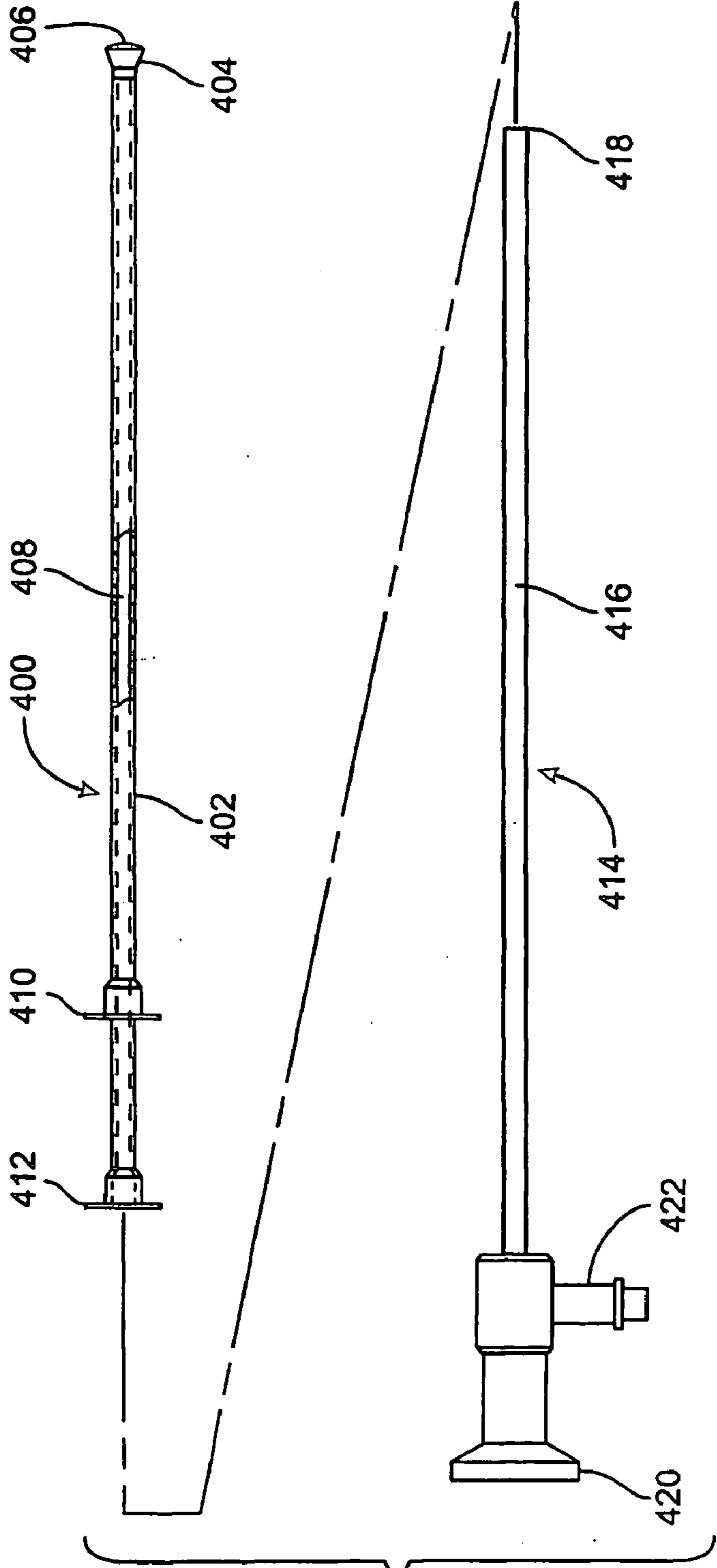

FIG. 35A

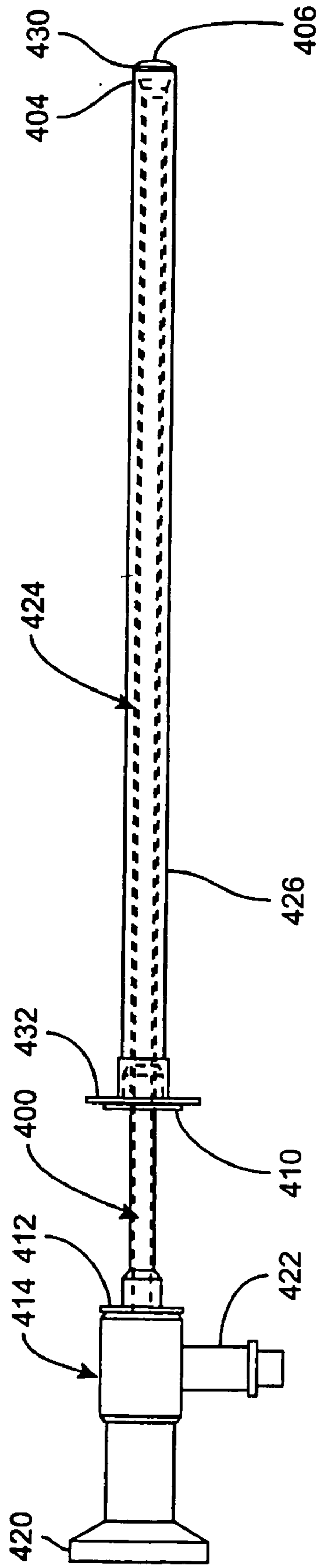

FIG. 35C

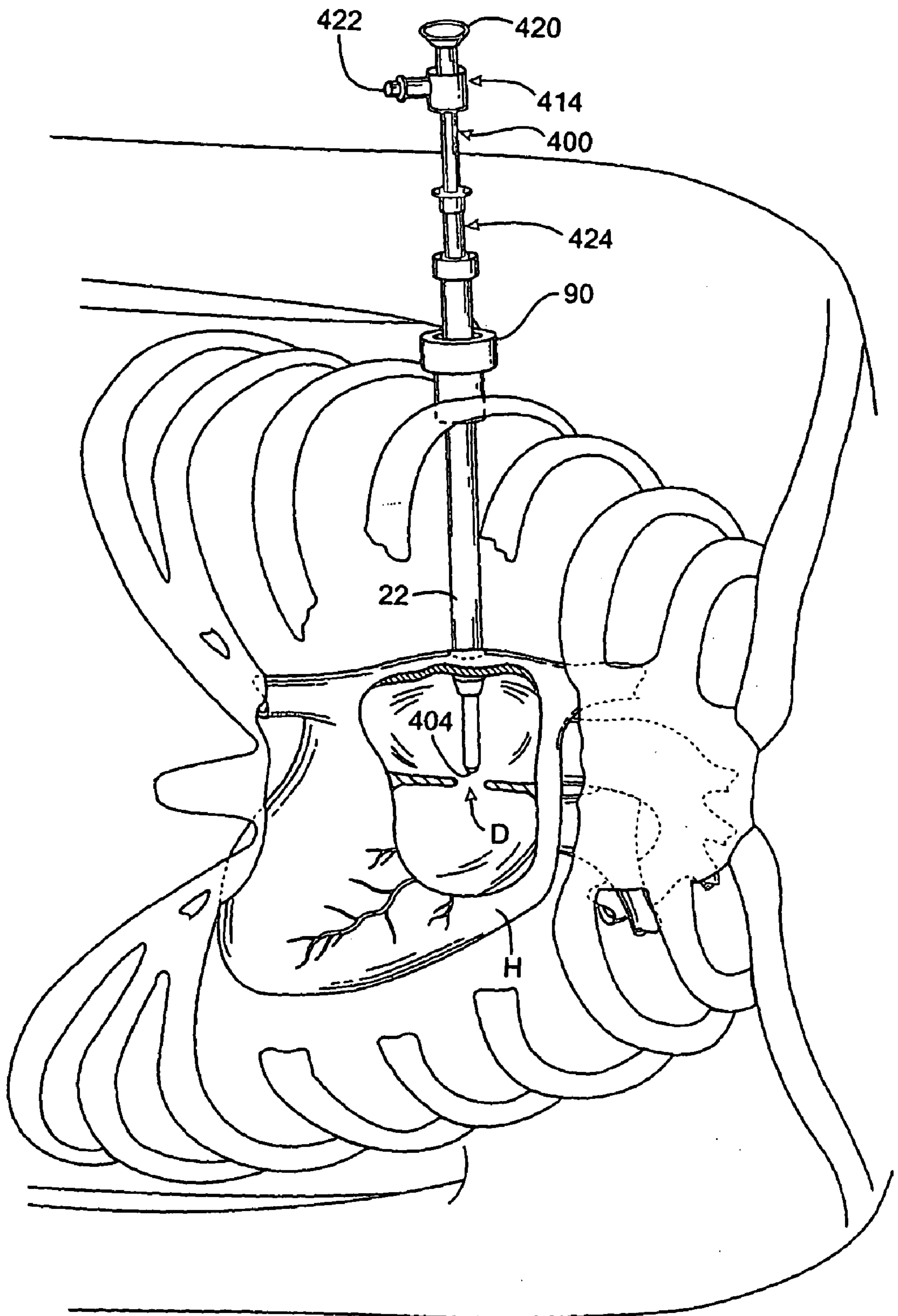

FIG. 36A

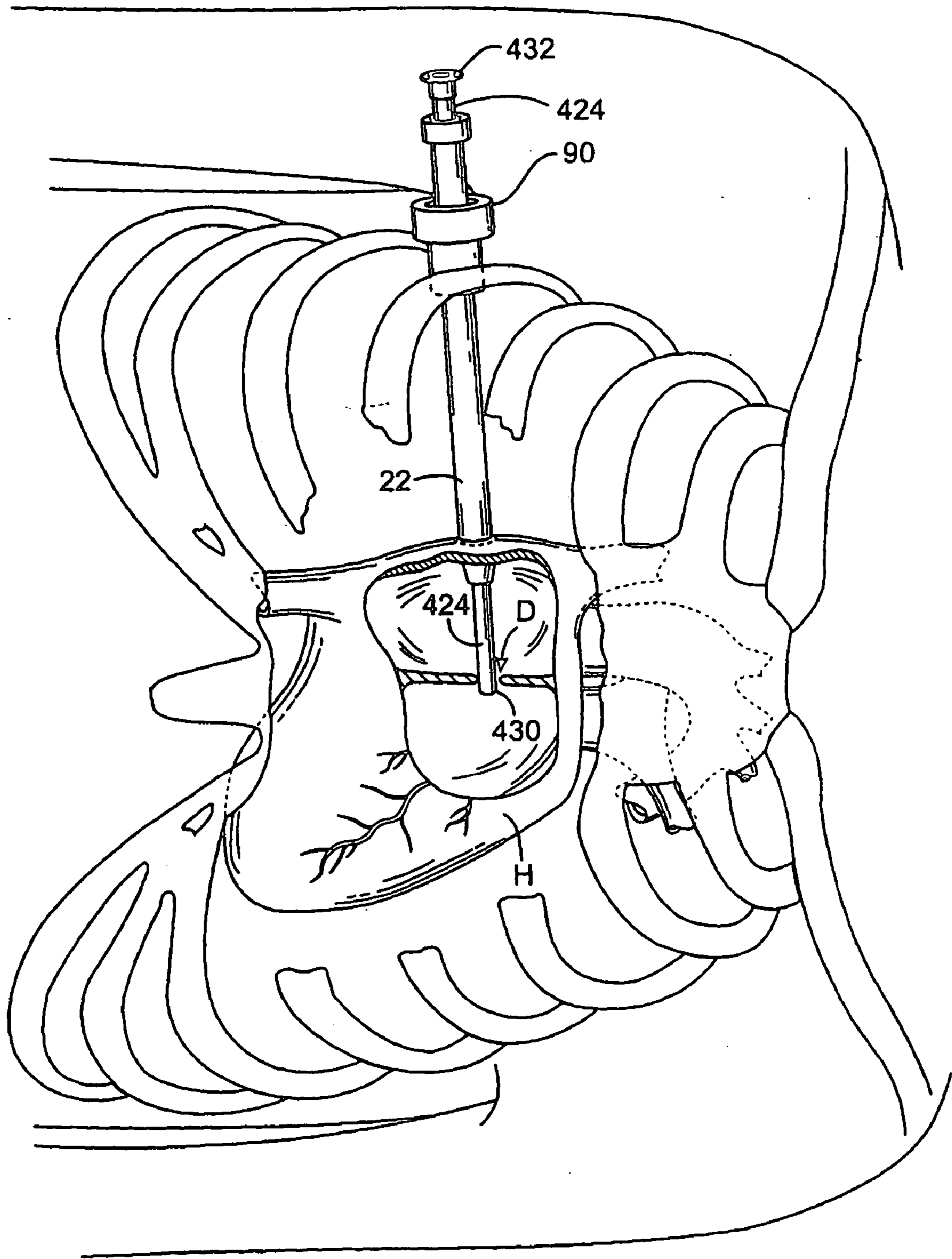

FIG. 36B

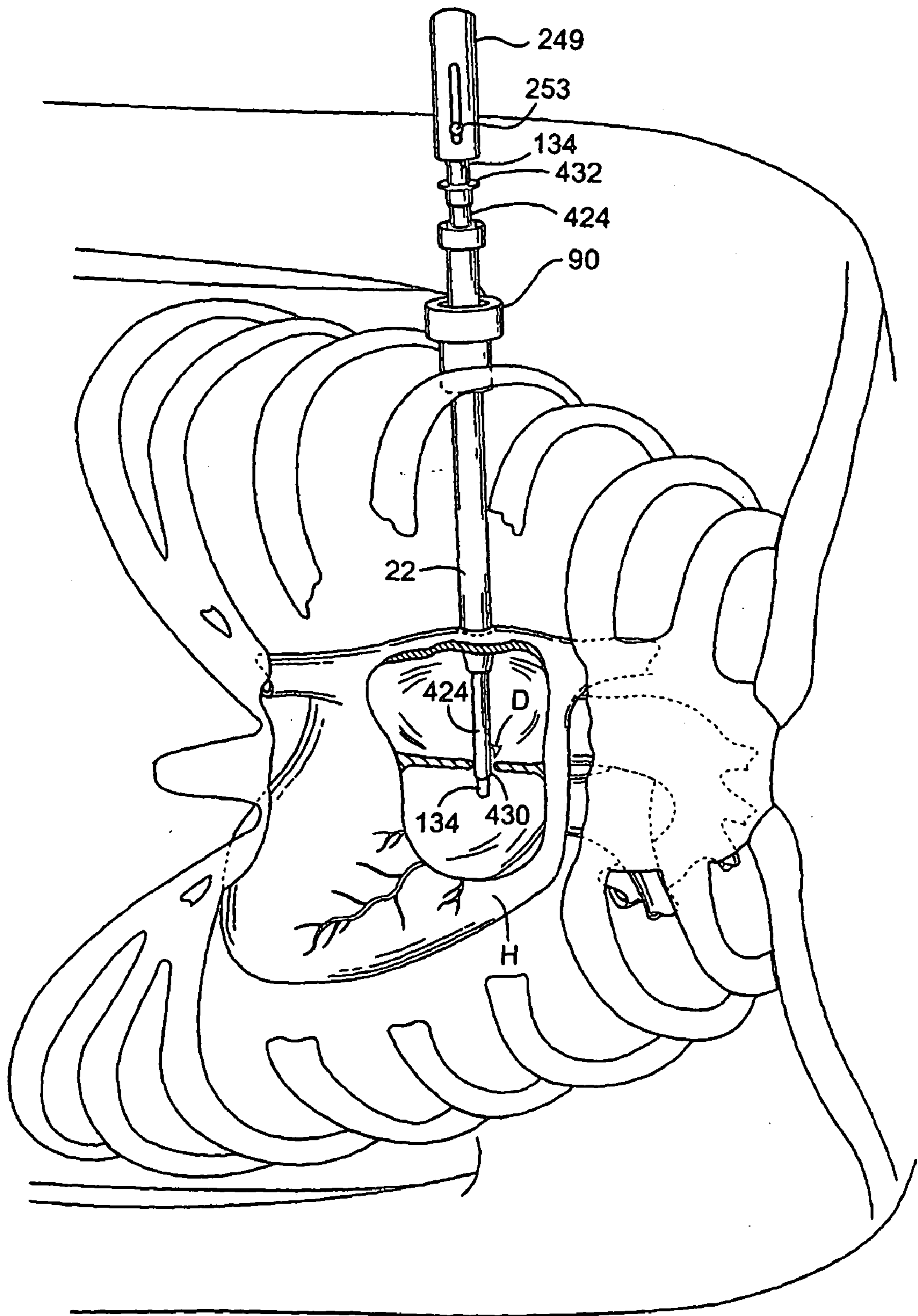

FIG. 36C

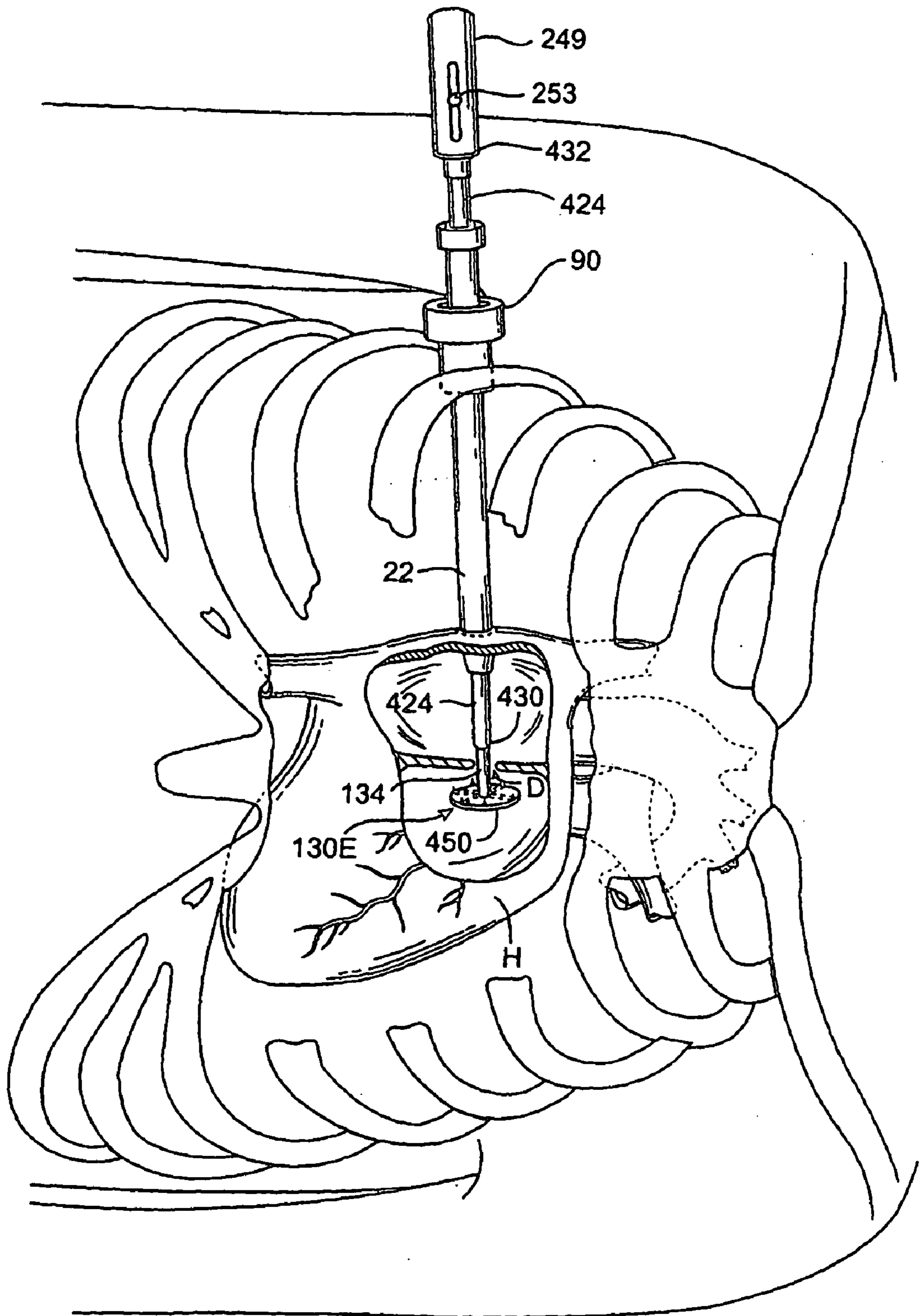

FIG. 36D

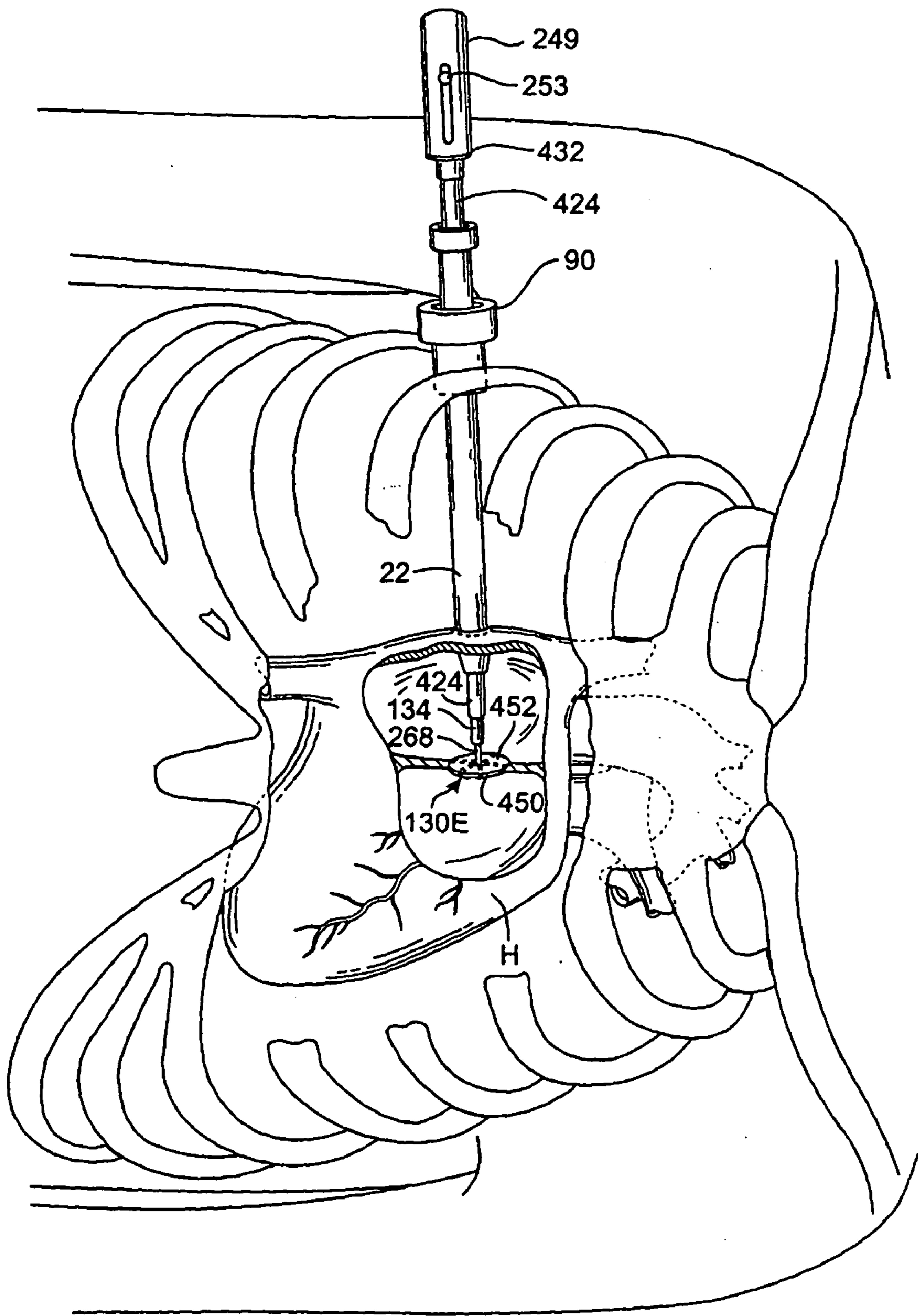

FIG. 36E

DEVICES FOR LESS-INVASIVE INTRACARDIAC INTERVENTIONS

CROSS-REFERENCE TO RELATED APPLICATIONS

[0001] This application is continuation-in-part of copending application Ser. No. 08/425,179, filed Apr. 20, 1995, which is a continuation-in-part of application Ser. No. 08/163,241, filed Dec. 6, 1993, which is a continuation in part of application Ser. No. 08/023,778, filed Feb. 22, 1993. The complete disclosures of all of these applications are hereby incorporated herein by reference for all purposes.

FIELD OF THE INVENTION

[0002] The present invention relates generally to less-invasive surgery of the cardiovascular system. More specifically, the invention relates to thoracoscopic devices and techniques for performing surgical procedures within the heart and great vessels while the heart is beating.

BACKGROUND OF THE INVENTION

[0003] Tens of thousands of people are born each year with congenital defects of the heart. Some of the more common types of congenital cardiac defects include atrial septal defect (ASD), ventricular septal defect (VSD), and patent ductus arteriosus (PDA). An ASD is a hole in the cardiac septum between the left and right atria, while a VSD is a hole in the septum between the left and right ventricles. Patent ductus arteriosus is incomplete closure of the opening between the pulmonary artery and the aorta that is present during fetal development. These conditions may cause blood to abnormally shunt from the right side of the heart to the left side of the heart without being properly oxygenated in the lungs, so that the body tissues supplied by the blood are deprived of oxygen. In addition, blood in the left side of the heart may shunt back to the right side through the defect rather than being pumped into the arterial system, causing abnormal enlargement of the right chambers of the heart.

[0004] ASD's, VSD's and PDA can frequently be surgically repaired with significant success. Smaller defects may be reparable by simply suturing the defect closed, while larger defects may require a patch of polyester, expanded polytetrafluoroethylene, or a portion of the patient's own pericardium to be sutured into the heart to cover and occlude the defect.

[0005] Ordinarily, such surgery is performed using open-chest techniques while the heart is under cardioplegic arrest and circulation is maintained by cardiopulmonary bypass. Using such techniques, a gross thoracotomy is created in order to gain access to the heart and great vessels, facilitating clamping and cannulation of the aorta for inducing cardioplegic arrest, and allowing instruments to be introduced into the chest cavity and into the heart to perform the surgical repair. The necessity of stopping the heart significantly heightens the risks attendant such procedures, particularly the risks of causing ischemic damage to the heart muscle, and of causing stroke or other injury due to circulatory emboli produced by aortic clamping and vascular cannulation. In addition, the creation of a gross thoracotomy produces significant morbidity and mortality, lengthens hospital stay and subsequent recovery, increases costs, and worsens the pain and trauma suffered by the patient. More-

over, many congenital defects are repaired in children under the age of ten years for whom the morbidity and mortality of open-chest surgery and cardioplegic arrest can be even greater than for older patients.

[0006] In an effort to avoid the necessity of grossly opening the chest and stopping the heart, a number of intravascular devices have been developed for repair of ASD's, VSD's, and PDA. For example, U.S. Pat. No. 3,874,388 to King et al. discloses an intravascular delivery catheter introduced intraluminally from a peripheral vein into the right side of the heart which can be used to position an artificial umbrella-like patch across a septal defect and to anchor the patch to the cardiac septum. Other intravascular delivery devices and artificial patches for the repair of septal defects can be seen in U.S. Pat. No. 5,334,217, U.S. Pat. No. 5,284,488, U.S. Pat. No. 4,917,089, U.S. Pat. No. 4,007,743, and PCT Application No. PCT/US92/10141.

[0007] While intravascular approaches to the repair of congenital defects may provide certain advantages, the most significant of which is the elimination of the need for gross thoracotomy and cardioplegic arrest, these techniques have suffered from a number of problems. One such problem is the difficulty in manipulating the artificial patches into position across a defect using only the proximal end of a long and flexible delivery catheter positioned through a tortuous arterial or venous lumen. Also problematic is the inadequacy of fixation of endovascularly-placed patches, creating a tendency of such patches to migrate or embolize after placement, which can allow blood to again shunt through the defect. In addition, once such a patch has been placed and the delivery catheter detached from the patch, relocating and repositioning the patch with the catheter is difficult, if not impossible, and may require open surgical correction. Moreover, in young children, the size of the peripheral vessels is extremely small, and damage to such vessels could have serious effects upon the growth of the child. Thus, the size of the devices which can be introduced through such vessels is greatly limited.

[0008] In addition to ASD, VSD, and PDA, various other types of cardiac disease also may be diagnosed and treated by intervention within the interior chambers of the heart. For example, some cardiac arrhythmias such as ventricular tachycardias, supraventricular tachycardias, and atrial fibrillation, may be diagnosed by obtaining access into an interior chamber of the heart and by performing electrophysiological mapping to identify abnormal conduction pathways. Once these abnormal conduction pathways are identified, in some cases the disease may be treated by ablating selected cardiac tissue using radiofrequency (RF) energy or a medical laser to eliminate the abnormal pathways. A number of endovascular approaches have been developed which attempt to allow intracardiac mapping and ablation using catheters introduced transluminally from peripheral vessels into the heart. Such devices are disclosed, for example, in U.S. Pat. Nos. 4,960,134, 4,573,473, 4,628,937, and 5,327,889. However, endovascular mapping and ablation devices suffer from many of the same problems suffered by endovascular septal defect repair devices, including a lack of control and precise positionability from the proximal end of these highly flexible and elongated devices, the significant size constraints of peripheral vessels, and the inability to position the devices in all potentially diseased sites within the heart.

[0009] What are needed, therefore, are devices and methods to enable the repair of ASD, VSD, PDA, and other congenital defects, as well as cardiac arrhythmias and other diseases of the heart, which eliminate the need for gross thoracotomy and cardioplegic arrest, but which overcome the forementioned problems with intravascular techniques. The devices and methods should facilitate a high level of control for precise manipulation within the heart. The devices and methods should produce a septal defect or PDA repair which is reliable and long-lasting, and should not be susceptible to migration, embolization, or reopening of a defect. The devices and methods for septal defect and PDA repair should allow the position of a repair patch to be inspected after initial placement and to be repositioned if necessary. Finally, the devices and methods should not risk damaging the peripheral vessels of the patient, nor should the size and configuration of the devices be limited by the size of the patient's peripheral vessels.

SUMMARY OF THE INVENTION

[0010] The invention provides devices and methods that facilitate thoracoscopic access into the interior of the heart whether or not the heart is beating. This intracardiac access can be used to perform a variety of diagnostic and treatment procedures within the heart without the need for a gross thoracotomy or cardioplegic arrest. The invention provides devices and methods for the performance of a number of different procedures including the repair of ASD, VSD, PDA, and other cardiac abnormalities, electrophysiologic mapping and ablation for the treatment of cardiac arrhythmias, as well as a variety of other intracardiac procedures that can be performed thoracoscopically on a beating heart.

[0011] In a first aspect of the invention, a tubular access device is provided for accessing an interior chamber of a patient's heart. The access device includes an elongated tubular body configured to extend percutaneously through an intercostal space between the ribs of the chest and through a muscular wall of the heart, and an inner lumen extending through the tubular body which provides an access channel into the heart. In an exemplary embodiment, the tubular access device has a length of at least 10 cm, and the inner lumen has a diameter of at least 5 mm. Preferably, the tubular access device is rigid to facilitate responsive and precise positionability from its proximal end.

[0012] In one embodiment, the access device includes means near a distal end thereof for sealing peripherally around a surrounding penetration in the muscular heart wall through which the access device is positioned. The sealing means may comprise one or a pair of inflatable balloons, a radially-expandable portion of the tubular body, or a flange at the distal end of the body. A purse string suture or other tissue-gathering means may be applied to the muscular heart wall surrounding the tubular body and tightened to prevent blood from flowing through the penetration around the access device.

[0013] The invention may further include an obturator positionable within an inner lumen of the tubular access device. The obturator may have means at its distal end for penetrating the muscular wall of the heart. The penetrating means may comprise a blade, radiofrequency electrode, or other type of cutting element. In a preferred embodiment, the obturator further includes means for selectively exposing

the penetrating means, which may include a movable actuator for extending and retracting the cutting means from the distal end of the obturator.

[0014] The access device may include a hemostasis valve in the inner lumen to prevent blood flow out of the heart through the inner lumen, and to allow instruments to be introduced through the inner lumen while maintaining hemostasis in the inner lumen. The hemostasis valve may be disposed at either the proximal end or the distal end of the access device. Alternatively, when the access device is utilized in the lower-pressure right atrium, right ventricle, or left atrium, the access device may be positioned in a generally vertical orientation so that blood flow through the inner lumen is prevented by the pressure head of blood within the inner lumen being greater than the pressure in the cardiac chamber, eliminating the need for a hemostasis valve. With the access device positioned through an intercostal space and through a wall of the heart, a straight and relatively large channel directly into the interior of the heart is available for the introduction of devices for diagnostic and treatment procedures.

[0015] The invention further provides an assembly for visualization and access within a body cavity, and particularly, for visualization and access into a patient's heart. The assembly includes a guide sleeve having a distal end, a proximal end, and a lumen therebetween. An endoscope is slidably positionable in the lumen, the endoscope having a shaft, a channel extending longitudinally through the shaft, at least one lens in the channel, and, usually, an eyepiece at the proximal end of the shaft. Alternatively, the endoscope may be of the type in which a video-imaging charge-coupled device (CCD) chip is mounted at the distal end of an elongated shaft and electronically coupled to a video processor which sends a video signal to a monitor. A transparent bulb is disposed at the distal end of the shaft outside of the channel and optically aligned with the lens. In this way, the transparent bulb serves to displace blood away from the distal end of the endoscope to allow the user to view the interior of the heart. Usually, the transparent bulb will be placed in contact with the intracardiac surface to be viewed, and the assembly then manipulated to inspect the surface or to identify a particular feature on the surface such as a septal defect.

[0016] The transparent bulb may be mounted to the distal end of the endoscope itself, or mounted to the end of a separate elongate sheath having a lumen in which the endoscope may be positioned with the distal end of the endoscope adjacent to the bulb. The use of a separate elongate sheath allows any of various commercially-available endoscopes to be utilized for intracardiac viewing without modification. The transparent bulb may also be mounted to a steerable endoscope having a deflectable end, or to a flexible sleeve in which a steerable endoscope may be positioned such that the sleeve may conform to the configuration of the endoscope.

[0017] In some embodiments, the transparent bulb is substantially rigid, being made of a clear, rigid polymer or glass. In other embodiments, the transparent bulb may be an expandable member such as an inflatable balloon, allowing the bulb to be collapsed into a small configuration for introduction into the heart, then expanded within the heart. The transparent bulb preferably has a transverse cross-

sectional area larger than the transverse cross-sectional area of the shaft, and may further have a convex distal surface, facilitating the viewing of an area within the heart that is wider than that seen through the endoscope alone.

[0018] The guide sleeve has a length sufficient to reach an interior of a patient's heart from outside the patient's chest, usually being at least about 15 cm for pediatric use, or at least about 20 cm for adult use. The entire assembly is positionable in the heart through the inner lumen of the access device described above, or may be directly positioned in the heart through a penetration in a wall of the heart and sealed by means of a purse-string suture. The guide sleeve usually has an outer diameter of less than about 12 mm, and is preferably rigid to facilitate positioning the guide sleeve by manipulation of its proximal end. The guide sleeve may alternatively be flexible, with rigidity being provided by the placement of a rigid obturator or the endoscope itself through the guide sleeve.

[0019] The access and visualization assembly is useful in various medical procedures, but will find particular utility in intracardiac procedures in which the heart is to remain beating, such as septal defect repair. In use, the guide sleeve and endoscope are positioned in the heart through the inner lumen of the access device of the invention or directly through a penetration in the heart wall. The transparent bulb is positioned in contact with the intracardiac surface to be viewed, such as the interatrial septum. The proximal end of the assembly is then manipulated from outside the chest to inspect the surface and identify the location of treatment, such as a septal defect. Once located, the distal end of the guide sleeve is positioned through the defect, and the endoscope and transparent bulb are then withdrawn from the guide sleeve. The guide sleeve thereafter provides a conduit directly to the septal defect from outside the heart without requiring further use of the endoscope or other visualization devices to locate the defect. Defect repair devices may then be positioned through the guide sleeve directly to the septal defect to achieve the repair.

[0020] The invention also provides systems and methods for repairing atrial and ventricular septal defects through the guide sleeve of the above-described access and visualization assembly. The septal defect repair system includes a closure device for closing or occluding the septal defect, and a delivery device for introducing the closure device through the guide sleeve and into the interior of the heart.

[0021] In a first embodiment, the closure device comprises a patch that may be attached to the cardiac septum to cover and occlude the septal defect. The patch includes a collapsible frame, and a flexible patch material attached to the frame. The flexible patch material may be an artificial biocompatible material such as polyester or expanded polytetrafluorethylene, or a portion of the patient's pericardium or other natural body membrane. The frame is configured to support the patch material at its outer edges in a generally flat configuration, and is sufficiently rigid to retain its shape against the pressure of blood within the heart, while having sufficient flexibility and resiliency to be collapsible for introduction through the inner lumen of the access device. In an exemplary embodiment the frame comprises a hub and a plurality of spokes extending radially outward from the hub. A circumferential wire or suture thread extending between the outer tips of the spokes may be provided to continuously

support the outer edges of the patch. The hub is a rigid material such as stainless steel, is small enough to fit within the inner lumen of the access device, and is configured to be detachably coupled to the distal end of an delivery shaft (described below). The spokes are flexible, resilient wires of Nitinol™ or other material exhibiting similar super-elastic characteristics. The patch may be mounted to the frame by sutures, heat welding, adhesive, or other means.

[0022] The patch includes a means for securing the patch to the cardiac septum. The securing means may comprise a second patch coupled to a central portion of the first patch and parallel thereto such that one patch may be positioned through the septal defect on the left side of the cardiac septum and the second patch positioned on the right side of the cardiac septum, with the outer edges of the two patches compressively engaging the cardiac septum between them. For example, in the hub and spoke embodiment describe above, two sets of spokes may be mounted to the hub and a patch mounted to each set of spokes so that the two patches are generally parallel to each other and spaced slightly apart. Alternatively, the securing means may comprise a plurality of flexible wire struts coupled to a central part of the frame such that the outer ends of the struts will compressively engage the cardiac septum on the side opposite that on which the patch is positioned. Like the patch, the securing means is collapsible to allow introduction through the inner lumen of the access device. To facilitate secure fixation to the septum, the frame or the securing means may include pins or spikes pointing generally perpendicular to the patch to partially penetrate the cardiac septum when the patch has been positioned across the defect, preventing migration of the patch.

[0023] The patch is introduced into the heart and positioned across the septal defect by means of a rigid delivery shaft which may be positioned through the guide sleeve. The delivery shaft includes an interior lumen or aperture at its distal end for receiving the patch and securing means in a collapsed configuration. The delivery shaft further includes a means for deploying the patch and the securing means, which may comprise a rod slidably disposed in a lumen through the delivery shaft. The rod includes means at its distal end for releasably coupling to the patch, such as a threaded extension which couples to a threaded hub in the patch frame. The rod may be advanced distally relative to the delivery shaft to deploy the patch from the aperture into the heart chamber on the side of the cardiac septum further away from the point of introduction, e.g., the left atrium if the device has been introduced into the heart through the right atrium. The patch is positioned against the septum, and the securing means is deployed on the side of the cardiac septum opposite the patch, e.g., the right atrium in the aforementioned case. The rod may then be decoupled from the patch and the delivery shaft is removed from the patient through the access device.

[0024] Advantageously, the delivery shaft and deployment means are configured to allow the patch to be re-collapsed and repositioned if the position of the patch is not satisfactory after initial deployment. In one embodiment, the rod is drawn proximally relative to the delivery shaft, whereby the patch is collapsed by engagement with the distal end of the delivery shaft. The patch securing means may be collapsed in a similar manner, or by a separate mechanism. In an exemplary embodiment, one or more wires or sutures extend

through a lumen in the delivery shaft and are coupled to the securing means, e.g. to the outer ends of the spokes or struts of the securing means. By exerting tension on the wires, the securing means is drawn proximally into a collapsed configuration to allow it to be received in the aperture in the delivery shaft. This allows the patch and securing means to be drawn back into the aperture in the delivery shaft and redeployed at the desired position.

[0025] In an alternative embodiment, the septal defect closure device comprises a suturing device for applying at least one suture across the septal defect. The suturing device includes a rigid delivery shaft suitable for introduction through the guide sleeve, and a plurality of needle holders mounted to the delivery shaft for releasably holding at least two needles connected by a suture thread. The needle holders are movable between a contracted position suitable for introducing the needles through the septal defect into the cardiac chamber on the opposite side of the septum, and an expanded position in which the tips of the needles are aimed proximally toward the cardiac septum on opposing sides of the septal defect. In one embodiment, the needle holders are mounted on opposing sides of a balloon which may be deflated during introduction through a septal defect and then inflated to move the needles into the expanded position. The needle holders are then pulled proximally so that the needles penetrate the cardiac septum. A means is mounted to the delivery shaft for capturing the distal tips of the needles after penetrating the septum. For example, the needles may have barbed tips which engage a porous fabric disk slidably mounted to the delivery shaft. The needle capture means is retracted to draw the needles through the septum and out of the heart through the inner lumen of the access device. In this way, a plurality of sutures may be applied to the cardiac septum simultaneously. Knots may then be tied in the sutures extracorporeally, and, using a long-handled endoscopic knot-pusher, pushed through the access device into the heart so as to tighten the sutures and draw the opposing sides of the septal defect together.

[0026] In a further aspect of the invention, a method of locating an opening in a patient's heart comprises the steps of positioning a visualization scope through a sleeve; positioning a distal end of the visualization scope into the heart through a penetration in a wall thereof; viewing the opening through the visualization scope; sliding the sleeve into the opening; and removing the visualization scope from the sleeve. The opening may comprise a septal defect, patent ductus arteriosus, or any of a variety of other intracardiac formations. The method may further include positioning the visualization scope in a sheath outside the heart such that a distal end of the visualization scope is adjacent to a transparent bulb on a distal end of the sheath; positioning the sheath in the heart through the sleeve; and viewing the opening through the transparent bulb.

[0027] If the opening is a septal defect or patent ductus arteriosus, the method may further include the steps of positioning a repair device through the sleeve while the sleeve is positioned through the opening; and closing the opening with the repair device. The repair device may comprise a patch which is secured across the opening, or a device for suturing the opening closed. In most embodiments, the visualization scope and the sleeve are positioned through an access device extending from outside the chest through the penetration in the wall of the heart.

[0028] While the method of the invention may find use in open-chest surgical procedures, it is preferably performed using thoracoscopic techniques, wherein the ribs and sternum remain intact and are not significantly retracted during each step of the procedure. Using such techniques, a working space may be created in the patient's chest cavity by collapsing one of the patient's lungs or using jet ventilation techniques. A viewing scope such as an endoscope or endoscopic surgical microscope may then be introduced through an intercostal space into the working space to view the exterior of the heart while the penetration is formed and the access device is introduced. The viewing scope may include a video camera to provide a video image of the heart for display on a monitor which can be viewed during the procedure. Alternatively, the heart may be viewed directly through a lens on the viewing scope or through a trocar sleeve positioned in an intercostal space. While it may be desirable to place the patient on cardiopulmonary bypass and arrest the heart during certain procedures, the invention facilitates the performance of a number of cardiac procedures while the heart is beating, without the need for cardiopulmonary bypass or cardioplegic arrest, and with significantly reduced risk of injury resulting from embolism.

[0029] Usually, the method will be performed in the right atrium, right ventricle, or left atrium, in which blood pressure is lower than in the left ventricle. Preferably, the access device is positioned in a vertical orientation, usually from a lateral side of the chest, with the distal end of the access device disposed in the interior chamber. In this way, the static pressure head of blood within the inner lumen is equal to the pressure within the interior chamber, preventing the flow of blood out of the interior chamber through the inner lumen. In an exemplary embodiment, small incisions and/or access ports are placed in the third, fourth, fifth, or sixth intercostal spaces on a lateral side of the chest. At least three such ports are usually required, one for introduction of the access device, one for introduction of a visualization device such as an endoscope, and one for introduction of other instruments for suturing, retraction, and other purposes.

[0030] In addition to the use of the assembly described above, visualization within the interior of the heart may be provided by various means. An ultrasonic probe may be positioned in the patient's esophagus, on the surface of the patient's chest, or in the chest cavity adjacent or in contact with the exterior of the heart to ultrasonically image the interior of the heart. An angioscope introduced into the heart endovascularly through a peripheral vessel may also be used for intracardiac visualization. Fluoroscopy is an additional technique for visualization.

[0031] The devices and methods of the invention may also be useful in other types of cardiac treatment procedures, including repair and replacement of cardiac valves, electrophysiological mapping and ablation, Cox "maze" surgical transection of the atrium, transmyocardial laser revascularization, pulmonary thrombectomy, intracardiac inspection, removal of growths, myxomas, neoplasms, hypertrophic obstructive cardiomyopathy and vegetations, and other diagnostic and treatment procedures.

[0032] The nature and advantages of the invention will become more apparent from the following detailed description of the invention when taken in conjunction with the accompanying exemplary drawings.

BRIEF DESCRIPTION OF THE DRAWINGS

- [0033] **FIG. 1** is a perspective view of an intracardiac access device according to the invention.
- [0034] **FIG. 2** is a front partial cut-away view of a patient's heart showing the intracardiac access device positioned through a wall thereof.
- [0035] **FIGS. 2A-2E** are side views of a distal portion of the intracardiac access device of **FIG. 1** showing various alternative types of sealing means.
- [0036] **FIGS. 3A-3C** are side, top, and end views, respectively, of the obturator of an intracardiac access device according to the invention with the cutting means retracted.
- [0037] **FIGS. 3D-3F** are side, top, and end views, respectively, of the obturator of an intracardiac access device according to the invention with the cutting means extended.
- [0038] **FIG. 4** is a front cut-away view of a patient's chest showing cutting the pericardium to expose the heart according to the method of the invention.
- [0039] **FIG. 5** is a front cut-away view of a patient's chest showing the placement of a purse-string suture in a muscular wall of the heart according to the method of the invention.
- [0040] **FIG. 6** is a front cut-away view of a patient's chest showing the penetration of the muscular wall of the heart according to the method of the invention.
- [0041] **FIG. 7** is a front cut-away view of a patient's chest showing the position of the access device of **FIG. 1** through the penetration in the muscular wall of the heart according to the method of the invention.
- [0042] **FIG. 8A** is a front cut-away view of a patient's chest showing the position of the access device of **FIG. 1** through the penetration in the muscular wall of the heart with a balloon-type sealing means expanded according to the method of the invention.
- [0043] **FIG. 8B** is a front cut-away view of a patient's chest showing the use of an endoscope having a balloon over its distal end in a method of visualizing the interior of the heart according to the invention.
- [0044] **FIG. 9** is a front cut-away view of a patient's chest showing the deployment of a distal patch of a septal defect repair device in a chamber of the heart according to the method of the invention.
- [0045] **FIG. 10** is a side elevational view of a partially-deployed distal patch of a septal defect repair device useful in the method of the invention.
- [0046] **FIGS. 11A-11B** are side cross-sectional and end views, respectively, of a hub of the distal patch of **FIG. 10**.
- [0047] **FIG. 12** is a side elevational view of a proximal patch of a septal defect repair device useful in the method of the invention.
- [0048] **FIGS. 13A-13B** are side cross-sectional and end views, respectively, of a hub of the proximal patch of **FIG. 12**.
- [0049] **FIG. 14** is a side cross-sectional view of the septal defect repair device of **FIGS. 10-13** positioned in a lumen of a delivery shaft according to the method of the invention.
- [0050] **FIG. 15** is a front cut-away view of a patient's chest showing the expansion of the distal patch of **FIG. 10** in the left side of the heart according to the method of the invention.
- [0051] **FIG. 16** is a front cut-away view of a patient's chest showing the deployment of the proximal patch of **FIG. 12** in the right side of the heart according to the method of the invention.
- [0052] **FIG. 17** is a front cut-away view of a patient's chest showing the expansion of the proximal patch of **FIG. 12** in the right side of the heart according to the method of the invention.
- [0053] **FIG. 18** is a front cut-away view of a patient's chest showing the attachment of the proximal patch to the distal patch to repair the septal defect according to the method of the invention.
- [0054] **FIG. 19** is a front cut-away view of a patient's chest showing the closure of the penetration in the muscular wall of the heart according to the method of the invention.
- [0055] **FIG. 20** is a transverse cross-sectional view of the patient's chest showing an alternative technique for closing the penetration in the muscular wall of the heart according to the method of the invention.
- [0056] **FIGS. 21A, 22A, and 23** are top partial cut-away views of alternative embodiments of a septal defect repair device according to the principles of the invention.
- [0057] **FIGS. 21B and 22B** are side cross-sectional views of the septal defect repair devices of **FIGS. 21A and 22A**, respectively.
- [0058] **FIG. 24A** is a top partial cut-away view of a further embodiment of a septal defect repair device according to the principles of the invention.
- [0059] **FIG. 24B** is a side partial cut-away view of the septal defect repair device of **FIG. 24A**.
- [0060] **FIG. 24C** is a front view of a further embodiment of a septal defect repair device according to the invention.
- [0061] **FIG. 24D** is a side cross-section of the septal defect repair device of **FIG. 24C**.
- [0062] **FIG. 24E** is a side view of the septal defect repair device of **FIG. 24C** with the patch material removed.
- [0063] **FIGS. 24F-G** are front and side views, respectively of a hub in the septal defect repair device of **FIG. 24C**.
- [0064] **FIG. 24H** is a side partial cross-section of the septal defect repair device of **FIG. 24C** in a collapsed configuration within a delivery shaft.
- [0065] **FIG. 25A** is a side cut-away view of the septal defect repair device of **FIGS. 24A-24B** positioned in a collapsed configuration within a delivery shaft.
- [0066] **FIG. 25B** is a side cut-away view of an actuator handle for deployment of the septal defect repair device of **FIGS. 24A-24B**.
- [0067] **FIGS. 26A-26B** is a side cross-sectional view showing the attachment of the septal defect repair device of **FIGS. 24A-24B** to a cardiac septum according to the method of the invention.

[0068] FIG. 27 is a front cut-away view of a patient's chest showing the introduction of a suturing device into the heart for repairing a septal defect in an alternative embodiment of the method of the invention.

[0069] FIG. 28 is a front cut-away view of a patient's chest showing the expansion of a plurality of needles at the distal end of the suturing device according to the method of the invention.

[0070] FIG. 29A is a front cut-away view of a patient's chest showing drawing the plurality of needles through the cardiac septum according to the method of the invention.

[0071] FIG. 29B is a side view of the cardiac septum in the patient's chest of FIG. 29A showing the position of the needles through the cardiac septum according to the method of the invention.

[0072] FIG. 30A is a side view of the cardiac septum of FIG. 29B showing capturing the needles in a capture disk according to the method of the invention.

[0073] FIG. 30B is a side view of the cardiac septum of FIG. 30A showing withdrawing the needles from the cardiac septum according to the method of the invention.

[0074] FIG. 31A is a top view of the cardiac septum of FIG. 30A showing the position of the sutures across the septal defect according to the method of the invention.

[0075] FIGS. 31B-31C are perspective views of the cardiac septum of FIG. 31A showing tensioning and tying the sutures to close the septal defect according to the method of the invention.

[0076] FIGS. 32A-32D are side views of an alternative embodiment of a suture-type septal defect repair device according to the invention, showing the deployment of the needles in the cardiac septum and the capture of the needles according to the method of the invention.

[0077] FIG. 33 is a front cut-away view of a patient's chest showing an electrophysiology device according to the invention positioned through the access device of FIG. 1 in a method of electrophysiological treatment according to the invention.

[0078] FIG. 34 is a front cut-away view of a patient's chest showing an alternative embodiment of an electrophysiology device according to the invention positioned through the access device of FIG. 1 in a method of electrophysiological treatment according to the invention.

[0079] FIGS. 35A-35C are side partial cut-away views of an intracardiac visualization and access device according to the invention.

[0080] FIGS. 36A-E are anterior views of a heart in a patient's chest schematically illustrating the use of the intracardiac visualization and access device of FIGS. 35A-C.

DETAILED DESCRIPTION OF SPECIFIC EMBODIMENTS

[0081] A first representative embodiment of an intracardiac access system according to the invention is illustrated in FIG. 1. The intracardiac access system 20 includes a tubular access device 22 comprising a rigid shaft 24 having a distal end 26, a proximal end 28, and an inner lumen 30

extending therebetween. Access device 22 includes a means near distal end 26 for hemostatically sealing a cardiac penetration through which shaft 24 is introduced, which may comprise a toroidal balloon 32. An inflation lumen 34 extends through shaft 24 and has an opening 36 in communication with the interior of balloon 32. An inflation fluid port 38 is mounted to shaft 24 at proximal end 28 in communication with inflation lumen 34 and is configured for connection to an inflation fluid delivery source such as a syringe or other balloon inflation device.

[0082] Access device 22 is configured to extend percutaneously through an intercostal space and through a muscular wall of the heart with distal end 26 positioned in an interior chamber of the heart and proximal end 28 positioned outside of the patient's chest cavity. In an exemplary embodiment, the tubular access device has a length of about 10 to 30 cm, preferably about 25 cm, and an outer diameter of less than about 15 mm, and preferably about 5-10 mm. To allow introduction of instruments for visualization and surgical intervention within the heart, inner lumen 30 has a diameter of at least about 5 mm. Preferably, access device 22 is a rigid material such as stainless steel, titanium, or a rigid polymer, with a minimum durometer of about 75 Shore A. Alternatively, shaft 24 of access device 22 may be all or partially flexible with a minimum durometer of about 35 Shore A, and may also include pull wires or other means for steering or deflecting distal end 26.

[0083] As illustrated in FIG. 2, distal end 26 of access device 22 is configured to be introduced through a penetration in cardiac wall 40 of heart H. The hemostatic sealing means, e.g. balloon 32, functions to seal the penetration around the exterior of shaft 24 to prevent leakage of blood through the penetration from the interior of heart H. As illustrated in FIGS. 2A-2E, a variety of hemostatic sealing means may be utilized. Balloon 32 may be mounted to shaft 24 spaced a short distance from distal end 26 so as to be positionable against the exterior surface of cardiac wall 40, as shown in FIG. 2A. Balloon 32 may alternatively be mounted close to distal end 26 so as to be positionable against the interior surface of cardiac wall 40 as shown in FIG. 2B. In addition, a pair of balloons 32, 42 may be mounted to shaft 24 spaced slightly apart to provide a seal on both sides of cardiac wall 40, as shown in FIG. 2C.

[0084] In a further alternative embodiment, not pictured, either or both of balloons 32, 42 of FIG. 2C may be replaced by expanding mechanical elements, such as moly-type fittings which are expanded under compression exerted by, for example, sliding a slidable sleeve axially over shaft 24 which engages the proximal ends of the fittings.

[0085] In a further embodiment, shown in FIG. 2D, shaft 24 may have a flange 44 disposed at distal end 26, flange 44 having a proximal end 46 with an outer diameter larger than that of shaft 24. When flange 44 is introduced through a cardiac penetration, proximal end 46 of flange 44 may be positioned so as to abut and seal against the interior surface of cardiac wall 40. Flange 44 preferably has tapered side walls 48 to facilitate introduction through the cardiac penetration. As shown in FIG. 2, balloon 32 may be mounted to shaft 24 spaced proximal to flange 44 to compress cardiac wall 40 between the balloon and the flange and seal the cardiac penetration both interiorly and exteriorly.

[0086] In another embodiment, illustrated in FIG. 2E, shaft 24 has a radially-expanding portion 50 near distal end

26 which may be selectively expanded when distal end **26** has been positioned through the cardiac penetration. Exemplary radially-expanding dilators and cannulae having a construction suitable for application to the present invention are disclosed in U.S. Pat. Nos. 5,183,464 and 4,921,479, which are incorporated herein by reference. A balloon **32** may also be mounted to shaft **24** distally of radially-expanding portion **50** to seal against the interior surface of cardiac wall **40**.

[0087] In each of the forementioned embodiments, it will frequently be advantageous to place a purse string suture in cardiac wall **40** or apply another means of gathering tissue around the cardiac penetration through which shaft **24** is introduced to enhance hemostasis. The placement of such a purse-string suture is described in detail below.

[0088] Referring now to FIGS. 3A-3C and 3D-3F, cardiac access system **20** further includes an obturator **52** removably positionable in inner lumen **30**. Obturator **52** comprises a tubular shaft **54** having a distal end **56**, a proximal end **58**, and an axial lumen **59**. Distal end **56** is conical in shape and has a transverse slot **57** in communication with axial lumen **59**. A cutting means **60** for forming a penetration in a heart wall is slidably received within slot **57**, and, in an exemplary embodiment, comprises a stainless steel blade **62** having a sharpened distal edge **64** tapering to a point **66**. Blade **62** is coupled to a linkage **72** slidably disposed in axial lumen **59**. A handle **74** is mounted to proximal end **58** of shaft **54**, and a sliding actuator **76** is mounted to handle **74**. Linkage **72** is coupled to actuator **76**, so that actuator **76** may be used to slide blade **62** distally to expose edge **64** and point **66**. A compression spring **78** is disposed within an aperture in handle **74** and engages a collar **79** on linkage **72** to bias blade **62** proximally so that it is protected within slot **57**.

[0089] Actuator **76** may be configured to lock in a distal position in which blade **62** is fully exposed, in a proximal position in which blade **62** is fully exposed, or in any other position between the two. In an exemplary configuration, actuator **76** comprises a button **77** having an upper portion **81** of smaller diameter which is slidable within a channel **80** in handle **74**, and having a lower portion **82** of larger diameter designed to seat within a detent **84** at the proximal end of channel **80**. Button **77** is biased upward by a spring **85** to automatically lock into detent **84** when aligned therewith. In this way, blade **62** is locked in the proximal position and is unlikely to be inadvertently exposed by the user. When exposure of blade **62** is desired, button **77** is pushed downward and distally. Release of pressure on button **77** causes blade **62** to retract automatically.

[0090] The length of shaft **54** is selected so that when obturator **52** is disposed within inner lumen **30**, cutting means **60** extends distally of distal end **26** of access device **22** and handle **74** is near or against proximal end **28** of access device **22**. In this way, blade **62** may be used to create a penetration in the heart wall while obturator **52** is positioned within access device **22**, allowing access device **22** to be introduced through the heart wall as or immediately after the penetration is formed, thereby minimizing blood loss through the penetration. Once access device **22** is introduced through the cardiac penetration, obturator **52** is withdrawn from inner lumen **30**.

[0091] As will be described more fully below, access device **22** is usually introduced into the right atrium, right

ventricle, or left atrium in a vertical or near-vertical orientation so that blood flow out of the heart through inner lumen **30** is prevented by gravity—i.e., the pressure head of blood in inner lumen **30** is equal to that in the cardiac chamber. In such cases, there is no need for a hemostasis valve within inner lumen **30**. However, in cases in which access device **22** is to be introduced into the higher pressure chamber such as the left ventricle, or in which access device **22** is to be positioned in an orientation in which blood might flow through inner lumen **30**, a hemostasis valve (not shown) may be provided within inner lumen **30**. The hemostasis valve may be positioned at the proximal end, the distal end, or a mid-position within inner lumen **30**, and will be configured to allow instruments to be introduced through inner lumen **30** with minimal blood loss. Suitable hemostasis valves are described, for example, in U.S. Pat. Nos. 4,000,739, 4,436,519, 5,154,701, 4,946,133, 5,000,745, 4,177,814, and 5,300,033, which are incorporated herein by reference.

[0092] A method of accessing the interior of the heart according to the invention will now be described with reference to FIGS. 4-8. The method will be described in relation to accessing a left or right atrium of the heart from the right side of the chest, but it should be understood that the principles described will be equally applicable to accessing the left or right ventricle and using any of a variety of approaches.

[0093] The patient is prepared for cardiac surgery in the conventional manner, and general anesthesia is induced. The patient is positioned on the patient's left side so that the right lateral side of the chest is disposed upward. Two to three small incisions 2-3 cm in length are made between the ribs, usually in the third, fourth, or fifth intercostal spaces. Thoracoscopic access ports **90** (e.g. trocar sleeves or other tubular cannulae), are positioned in each incision to retract away adjacent tissue and protect it from trauma as instruments are introduced into the chest cavity. Access ports **90** have an outer diameter which does not require retraction, cutting or removal of ribs, preferably less than 14 mm, and an axial passage with a diameter less than about 12 mm. Access ports **90** may also be non-circular in cross-section, or may be made of a flexible material to deform into a non-circular shape when introduced between two ribs. The right lung is deflated using conventional techniques, usually by introducing a tube through the patient's trachea into the right lung and applying a vacuum through the tube to deflate the lung. An endoscopic visualization device such as a thoracoscope **92** connected to a video monitor (not shown) by a cable **93** is introduced through one of access ports **90** to visualize the interior of the chest cavity. Atraumatic retraction instruments may be introduced through access ports **90** to assist in deflating and retracting the lung, thereby providing a working space within the chest cavity.

[0094] Referring to FIG. 4, in order to gain access to the heart, an opening is made in the pericardium **94** using thoracoscopic instruments introduced through access ports **90**, including thoracoscopic scissors **96** and thoracoscopic forceps **98**. Instruments suitable for use in this procedure are described in U.S. Pat. No. 5,501,698, which is incorporated herein by reference. An opening approximately 2 cm-8 cm square is formed in the pericardium, exposing the exterior of the heart **100**.

[0095] As shown in FIG. 5, a purse string suture **102** is then placed in the wall **104** of heart **100** around the site at

which it is desired to introduce access device **22**. This is accomplished by using thoracoscopic needle drivers **106** to introduce into the chest cavity a curved suture needle **108** attached to one end of a suture thread **110**, and to drive the needle through the heart wall to form a running stitch in a circular pattern approximately 12-14 mm in diameter. A double-armed suture may also be used, wherein the suture thread **110** has needles at both ends, allowing each needle to be used to form one semi-circular portion of the purse-string. Suture thread **110** may be long enough to allow both ends of the suture to be drawn outside of the chest cavity once purse-string suture **102** has been placed, or it may be shorter and manipulated within the chest cavity using thoracoscopic instruments. Suture needle **108** is then cut from thread **110** using thoracoscopic scissors.

[0096] Access device **22** may now be introduced into heart **100**. In some cases, it may be advantageous to first place the patient on cardiopulmonary bypass and to place the heart under cardioplegic arrest before introducing access device **22**. Preferably, however, heart **100** remains beating during the procedure to avoid the trauma and risks associated with cardioplegic arrest. Obturator **52** is positioned within inner lumen **30** of access device **22** so that distal end **56** of the obturator is exposed distally of distal end **26** of the access device. Access device **22** with obturator **52** positioned therein is introduced through an access port **90** into the chest cavity, and distal end **56** of the obturator is positioned against heart wall **104** centrally within the bounds of purse-string suture **102**. Button **77** on handle **94** of the obturator is then pressed downward and distally so as to extend blade **62** from distal end **56**, causing blade **62** to penetrate through heart wall **104**. A thoracoscopic grasping instrument (not shown) may be used to grasp the heart wall near purse string suture **102** to counter the insertion force of blade **62** and access device **22**. As blade **62** penetrates the heart wall, access device **22** is advanced distally in conjunction with obturator **52** so that both devices extend into the heart through the penetration **114** formed in heart wall **104**.

[0097] Once distal end **26** of access device **22**, including balloon **32** or flange **44** if used, is within the interior of heart **100**, purse-string suture **102** is cinched tightly to form a hemostatic seal around access device **22**, as shown in FIG. 7. One or a pair of thoracoscopic cinching devices **116** may be used for this purpose. Each cinching device **116** comprises a shaft **118** with a slidable hook **120** at its distal end which can be used to grasp a loop of purse-string suture **102**. Hook **120** may be retracted proximally to frictionally retain suture thread **110** against the distal end of shaft **118**. Loops on opposing sides of purse-string suture **102** may be grasped in this manner, and cinching devices **116** then withdrawn proximally to cinch purse-string suture **102** tightly, thereby gathering heart wall tissue against the exterior of access cannula **22** to form a hemostatic seal. Cinching devices **116** may be clamped in position to maintain tension on suture thread **110**. Alternatively, a slidable sleeve **122** may be provided around shaft **118**. Once a suture loop has been secured in hook **120**, slidable sleeve **122** may be slid distally relative to shaft **118** until it abuts against the surface of heart wall **104**. Shaft **118** is then pulled proximally relative to sleeve **122** to obtain the desired degree of tension on suture thread **110**. Sleeve **122** is configured to frictionally retain shaft **118** in position to maintain tension on the suture.

[0098] If a balloon or radially-expanding portion of access device **22** is used to enhance hemostasis, it is now activated. The use of a balloon **32**, described above in reference to FIG. 2B, is illustrated in FIG. 8A. Once distal end **26** of access device **22** is introduced into the interior of heart **100**, balloon **32** is inflated by introducing an inflation fluid such as saline through inflation lumen **34** (FIG. 1). A syringe or other commercially-available inflation device connected to inflation port **38** may be used for this purpose.

[0099] Obturator **52** is then withdrawn from inner lumen **30** of access device **22**. As described above, access device **22** is preferably positioned in a vertical orientation so that outflow of blood from the heart through inner lumen **30** is prevented by gravity—that is, the pressure head of blood within inner lumen **30** is equal to that in the cardiac chamber. In other cases, a hemostasis valve (not shown) is provided within inner lumen **30** to prevent blood flow from the heart, while allowing instruments to be introduced through the access device.

[0100] The patient has now been prepared for a diagnostic or treatment procedure to be carried out within heart **100** through access device **22**. Advantageously, the need for gross thoracotomy, cardiopulmonary bypass and cardioplegic arrest have been avoided, while providing a relatively large, straight, and hemostatically-sealed access passage directly into the interior of the heart.

[0101] Visualization within the heart may be accomplished in any of several ways. Trans-esophageal echocardiography may be used, wherein an ultrasonic probe is placed in the patient's esophagus or stomach to ultrasonically image the interior of the heart. An ultrasonic probe may also be placed through one of access ports **90** into the chest cavity and adjacent the exterior of the heart for ultrasonically imaging the interior of the heart.

[0102] Alternatively, as illustrated in FIG. 8B, an endoscope **121** having an optically transparent bulb such as an inflatable balloon **123** over its distal end **125** may be introduced through access device **22** into the interior of the heart. Balloon **123** may be inflated with a transparent inflation fluid such as saline to displace blood away from distal end **125** and may be positioned against a site such as septal defect D in septum S, allowing the location, shape, and size of defect D to be visualized. In one embodiment, endoscope **121** is a conventional, commercially-available endoscope such as a V. Mueller Model No. LA 7005 (V. Mueller, Inc, Deerfield, Ill.), having a tubular shaft **127** in which one or more lenses (not shown) are mounted, an eyepiece **129** at its proximal end for looking through tubular shaft **127**, and a connector **131** for connection to a light source which transmits light through optical fibers (not shown) extending through tubular shaft **127** to distal end **125**. Endoscope **121** is slidably positioned in an outer sleeve **133** having a distal end **135** to which balloon **123** is attached. Outer sleeve **133** has a luer connection **137** on its proximal end in communication with an inflation lumen (not shown) extending through outer sleeve **133** to an outlet port **139** at distal end **135** within the interior of balloon **123**. Luer connection **137** is adapted for connection to a syringe **141** for injecting a transparent inflation fluid such as saline into balloon **123** for inflation thereof. A tubular, compliant seal **143** is attached to a proximal end of outer sleeve **133** to provide a fluid-tight seal between endoscope **121** and outer

sleeve **133**. It will be understood to those of skill in the art that, instead of using separate outer sleeve **133**, balloon **123** could be mounted directly to distal end **125** of endoscope **121** and an inflation lumen provided in shaft **127** for inflation of the balloon.

[0103] In use, endoscope **121** is positioned in outer sleeve **133** outside of the patient, and the two are together introduced through inner lumen **30** of access device **22** with balloon **123** evacuated of fluid in a collapsed configuration. Once balloon **123** is within the heart, saline is injected into balloon **123** to inflate the balloon to a diameter of approximately 2-6 cm. Balloon **123** is then positioned against the site to be visualized, e.g., septum **S** around defect **D**. The size and location of the defect **D** may then be visualized by looking through eyepiece **129**. Additionally, endoscope **121** may include a video camera mount to allow video imaging and remote viewing of the interior of the heart on a video monitor.

[0104] Instead of a balloon or bulb over distal end **125**, saline may be injected under pressure through a lumen in endoscope **121** or in outer sleeve **131** and out of a port at or near distal end **125** to displace blood away from the distal end to provide a transparent field of view.

[0105] As a further visualization alternative, an endoscope may be utilized which employs a specialized light filter, so that only those wavelengths of light not absorbed by blood are transmitted into the heart. The endoscope utilizes a CCD chip designed to receive and react to such light wavelengths and transmit the image received to a video monitor. In this way, the endoscope can be positioned in the heart through access device **22** and used to see through blood to observe a region of the heart. A visualization system based on such principles is described in U.S. Pat. No. 4,786,155, which is incorporated herein by reference.

[0106] In still another alternative for visualization, particularly useful in imaging an atrial or ventricular septal defect, a very small-profile light source such as an optical fiber is positioned in the left atrium or left ventricle, opposite the right atrium or right ventricle in which access device **22** is positioned. The light source may be introduced through access device **22** and through the septal defect into the left side of the heart, or it may be introduced through a minute puncture in the left side of the heart. The puncture may be closed by a purse-string suture if needed. An endoscope is then positioned through access device **22** into the right side of the heart opposite the light source. The endoscope utilizes a CCD chip designed to receive and react to those light wavelengths transmitted through blood, as well as any light wavelengths transmitted through the interatrial or interventricular septum. This produces a shadow-like image of the septal defect, which is received by the CCD and displayed on a video monitor, thereby imaging the size, shape and location of the septal defect.

[0107] With access device **22** in position in the heart and a means of visualization in place, a number of intracardiac procedures may be performed. One such procedure is the repair of atrial septal defects, which will now be described with reference to FIGS. 9-32.

[0108] FIGS. 9-20 illustrate an exemplary embodiment of a system and method for repairing an atrial septal defect according to the invention. In these Figures, an umbrella-

type septal defect repair patch is shown which is similar to that that described in U.S. Pat. No. 3,874,388 to King, which is incorporated herein by reference. It should be understood, however, that any of a number of different septal defect repair patches may be utilized in conjunction with the system and method of the invention without departing from the principles hereof. Some of the septal defect repair patches which could be utilized are described, for example, in U.S. Pat. Nos. 4,007,743, 5,334,217, 4,917,089, 5,284,488, and 5,108,420, which are incorporated herein by reference. Another septal defect repair patch which could be used with the present invention is disclosed in PCI application No. PCI/US92/10141 to Pavcnik, published Jun. 10, 1993.

[0109] As shown in FIG. 9, the septal defect repair system of the invention includes, in addition to access device **22** described above, a defect repair device **130** and a delivery means **132**. Defect repair device **130** comprises, in this embodiment, a double umbrella-type patch similar to that described in the '388 patent to King. Delivery means **132** comprises a tubular delivery shaft **134** having a distal end **136** positionable through inner lumen **30** of access device **22**, and a proximal end (not illustrated in FIG. 9) which is used to manipulate delivery means **132** from outside of the chest cavity. An outer tubular control rod **138** is slidably disposed within delivery shaft **134**, and an inner control rod **140** is slidably disposed within outer control rod **138**. Inner control rod **140** has a distal end **142** detachably coupled to a distal patch **144** of defect repair device **130**.

[0110] Preferably, delivery shaft **134** is generally straight and rigid to facilitate introduction through access device **22** and manipulation of delivery means **132** from its proximal end. Delivery shaft **134** is thus stainless steel, titanium, another biocompatible metal, or a biocompatible polymer with a minimum durometer of 75 Shore A. Outer control rod **138** and inner control rod **140** are preferably also a rigid material such as stainless steel or titanium, although some flexibility may be tolerated in these members since they are supported exteriorly by delivery shaft **134**, so long as the inner and outer control rods have sufficient column strength to perform their respective functions, as described below.

[0111] The details of an exemplary embodiment of defect repair device **130** are illustrated in FIGS. 11, 12A-12B, 13 and 14A-14B, which show a double-umbrella device similar to that disclosed in the King patent. FIG. 11 illustrates distal patch **144**, which includes a central hub **146** to which a plurality, e.g. six, radially-extending struts **148** are coupled. Hub **146** and struts **148** are a rigid material such as stainless steel or a biocompatible polymer. Struts **148** include sharpened points **149** pointing generally perpendicular to the struts at their outer ends for penetrating the cardiac septum. A biocompatible flexible fabric **150** of a polyester such as Dacron™, an expanded polytetrafluoroethylene such as Gore-Tex® (W. L. Gore and Assoc., Inc.), silk, nylon, silastic, a portion of the patient's pericardium, or other biocompatible flexible material impervious to blood is attached to hub **146** by a keeper **152** and to struts **148** by sutures **154**.

[0112] As shown in FIGS. 11A-11B, struts **148** may be hingedly coupled to hub **146** by means of a hinge ring **156** which extends through an eyelet **158** at the end of each strut. Hinge ring **156** and struts **148** are retained on hub **146** by

keeper 152. Alternatively, struts 148 may be a resilient, flexible material and rigidly coupled to hub 146 so as to naturally assume a radially expanded configuration when unrestrained. A plurality of axial grooves 159 are provided on hub 146 to receive struts 148 when collapsed inward. Hub 146 further includes a threaded hole 160 on its proximal end into which the threaded distal end of inner control rod 140 may be threaded. A circumferential flange 162 is disposed about the proximal end of hub 146 for attachment to the proximal patch of the defect repair device, as described below.

[0113] Referring to FIGS. 12 and 13A-13B, defect repair device 130 further includes a proximal patch 164 having a construction much like distal patch 144. A plurality of struts 166 are hingedly coupled to a central hub 168 by means of a hinge ring 170 extending through eyelets 172 in the inner ends of the struts. Each strut 166 has an inwardly extending point 174 at its outer end for engaging the cardiac septum. A flexible fabric membrane 176 is attached to hub 168 by a keeper 180 and to struts 166 by sutures 182. Additional suture loops 184 are attached to struts 166 to allow attachment of tie wires for deployment of proximal patch 164, as described below.

[0114] As shown in FIGS. 13A-13B, hub 168 has a plurality of axial grooves 186 for receiving struts 166 in a collapsed configuration. Hub 168 also has an axial passage 188 of sufficient diameter to allow inner control rod 140 to extend slidably through it with minimal friction. On its distal end, hub 168 has a cavity 190 having an annular groove 192 for receiving circumferential flange 162 of hub 146 in a snap-fit relationship.

[0115] Referring to FIG. 14, during introduction through access device 22, distal patch 144 and proximal patch 64 are preferably positioned in a collapsed configuration within delivery shaft 134 near distal end 136. Inner control rod 140 is positioned slidably through outer control rod 138, through axial passage 188 in hub 168 of proximal patch 164, and threaded into hole 160 in distal patch 144. Tie wires 194 are attached to suture loops 184 and extend proximally through delivery shaft 134 out of the chest cavity. As shown in FIG. 9, delivery shaft 134 is introduced through the right atrium RA and into the left atrium LA through septal defect D. Inner control rod 140 is then advanced distally relative to delivery shaft 134 to deploy distal patch 144 out of delivery shaft 134 into left atrium LA.

[0116] As illustrated in FIG. 15, with distal patch 144 deployed in the left atrium, inner control rod 140 is pulled proximally relative to delivery shaft 134 until distal end 136 of the delivery shaft engages struts 148 (not shown in FIG. 15), urging struts 148 outward to a radially expanded position in which distal patch 144 is generally disk-shaped and parallel to cardiac septum S. Delivery shaft 134 and control rod 140 are then pulled proximally in the direction of arrow A1 until distal patch 144 engages septum S and points 149 of struts 148 partially penetrate septum S. This is done under visualization by TEE or one of the other techniques described above in order to ensure proper positioning of distal patch 144 so as to fully block blood flow across defect D. If, after initial placement, shunting of blood is detected across the defect, distal patch 144 may be repositioned by advancing delivery shaft 134 distally to disengage patch 144 from septum S, then manipulating delivery shaft

134 to position distal patch 144 in the desired location. The straightness, rigidity, and relatively short length of delivery shaft 134 provide the user a high degree of control and precision in placing the patch in the best possible position on septum S.

[0117] In some cases it may be desirable to have the capacity to re-collapse distal patch 144 and replace it within delivery shaft 134 for repositioning or removal from the patient. In such cases, tie wires may be provided which are coupled to the inner sides of struts 148 and extend through delivery shaft 134 out of the chest cavity. By tensioning the tie wires, struts 148 may be urged back into a collapsed position and distal patch 144 then pulled back into delivery shaft 134.

[0118] With distal patch 144 anchored in septum S, proximal patch 164 is next deployed in the right atrium RA, as illustrated in FIG. 16. This is accomplished by pulling delivery shaft 134 proximally to provide some space between its distal end 136 and septum S. Outer control rod 138 is then advanced distally relative to delivery shaft 134 to deploy proximal patch 164 out of delivery shaft 134 in the direction of arrow A2. Proximal patch 164 and outer control rod 138 slide relative to inner control rod 140, which is maintained in tension to keep distal patch 144 against septum S.

[0119] As shown in FIG. 17, tie wires 194 are then tensioned so as to urge struts 166 outward into a radially expanded position in which proximal patch 164 is generally disk-shaped and parallel to septum S. As illustrated in FIG. 18, outer control rod 138 and proximal patch 164 are then advanced distally over inner control rod 140 until hub 168 of the proximal patch engages and snaps into hub 146 of distal patch 144. Points 174 on the ends of struts 166 partially penetrate septum S to anchor the patch in position. Tie lines 194 are removed from proximal patch 164, by, for example, cutting the tie lines with a cutting instrument introduced through access device 22 after removal of delivery shaft 134. Alternatively, tie lines 194 may be looped through suture loops 184 on proximal patch 164 so that both ends extend out of the chest cavity, in which case one end of each tie line is simply pulled through the suture loop to remove the tie line.

[0120] It will be understood to those of ordinary skill in the art that a variety of different types of actuators of well-known construction may be employed at the proximal end of delivery means 132 to allow the user to selectively deploy defect repair device 130 in the heart. In one embodiment, not pictured, a handle is fixed to the proximal end of delivery shaft 134 which is suitable for being grasped in the user's hand. A pair of slidable buttons are mounted to the handle, one being coupled to the proximal end of the inner control rod 140 and the second being coupled to the proximal end of outer control rod 138. In this way, the user can independently deploy distal patch 144 and proximal patch 164 by sliding the respective buttons on the handle. A passage is also provided in the handle in communication with the interior of delivery shaft 134 to allow tie wires 194 to extend out of the delivery shaft outside of the patient's body.

[0121] Delivery shaft 134, along with inner control rod 140 and outer control rod 138, are then removed from the chest cavity through access device 22. If desired, the defect repair may be inspected by placing an endoscope with a

transparent bulb or balloon over its distal end through access device **22** into right atrium RA. The bulb or balloon is positioned against septum S and/or proximal patch **164** to inspect the position of the patch and to determine whether the septal defect has been completely occluded. Shunting of blood may also be detected using TEE or other ultrasonic technique. If patch position is satisfactory, access device **22** may be removed from the patient. Balloon **32** (if used) is deflated, and access device **22** is withdrawn from the penetration in heart wall **104**. As shown in **FIG. 19**, sutures **110** are pulled tight as access device **22** is withdrawn to close the penetration without significant loss of blood from the heart. Knots are tied in sutures **110**, usually extracorporeally, and slid into the chest cavity and against heart wall **104** using an endoscopic knot pusher **196** introduced through access port **90**. This may be done under visualization with an endoscope introduced through a separate access port **90** (not shown in **FIG. 19**). Sutures **110** are then trimmed off with a pair of endoscopic scissors.

[0122] An alternative method of closing the penetration in the heart wall is illustrated in **FIG. 20**. In this technique, an endoscopic staple applier is used to apply one or more staples to the heart wall across the penetration. A staple applier such as, for example, an AutoSuture™ Powered Multifire Endo TA60 device available from United States Surgical Corp. of Norwalk, Conn., may be utilized. Under visualization using an endoscope positioned in an access port **90**, stapler **198** is introduced through an access port **200** in the anterior wall of the patient's chest so that the anvils **202** are generally parallel to heart wall **104**. The heart wall around the penetration is pursed up using endoscopic forceps so that anvils **202** can be positioned around a portion of the myocardium that includes the penetration. The stapler is then actuated, applying a row of staples through the heart wall across the penetration to seal it closed.

[0123] With the penetration in heart wall **104** closed, the procedure is completed by removing all access ports **90** and closing all percutaneous incisions. The right lung is re-inflated, the endotracheal tube is removed, and the patient is recovered from anesthesia.

[0124] Additional embodiments of defect repair device **130** of the invention are illustrated in **FIGS. 21A-21B, 22A-22B, 23, and 24A-24B**. Defect repair devices **130A, 130B, 130C** of **FIGS. 21-23** each include a distal patch **206, 208, 210**, and a proximal patch **212, 214, 216**. The patches are a flexible, biocompatible, and blood impervious material, preferably conducive to endothelialization after implantation. Suitable materials include polyester mesh, knit fabrics of expanded polytetrafluoroethylene treated for low porosity, absorbable polyhydroxybutyrate, autologous pericardium, bovine or porcine pericardium, polyurethane and polypropylene mesh. The proximal and distal patches are attached together in a parallel relationship by an attachment means **218, 220, 222** forming a ring at the center of the patches. Attachment means **218** may comprise a single suture in a circular running stitch, a plurality of individual knotted suture loops, rivets, or other fasteners, or adhesive bonding, heat welding, or ultrasonic welding. A wire support frame **224, 226, 228** is attached around the outer edges of the distal and proximal patches, preferably by folding the outer edges of the patch around the frame and suturing or bonding the patch to itself, thereby enclosing the support frame within the patch material. On each patch, support frame **224,**

226, 228 is preferably a single continuous wire of Nitinol™, a superelastic nickel-titanium alloy available from Raychem Corporation, titanium, or stainless steel. Support frame **224, 226, 228** includes a plurality of loops **230, 232, 234** formed in the plane of each patch to allow for longitudinal flexing and bending of the frame to facilitate collapsing the patches during introduction. The loops may be formed outwardly to lie outside of the periphery of each side of the frame as illustrated in **FIG. 21A**, or inwardly to lie within the periphery of the frame as illustrated in **FIGS. 22 and 23**.

[0125] In the embodiment of **FIGS. 22A-22B**, defect repair device **130B** includes a central hub **236** attached to distal and proximal patches **208, 214**. Hub **236** has a post **238** extending through patches **208, 214**, and a retainer **240** threaded or press-fit onto the distal end of post **238**, thereby fixing hub **236** to the patches. Hub **236** also has a threaded hole **242** in its proximal end to which an introducer shaft may be threadably coupled. By allowing defect repair device **130** to be coupled to an introducer shaft via hub **236**, the user is given a higher degree of control in positioning and repositioning the patch, as described more fully below. It should be understood that any of the embodiments in **FIGS. 21A-21B and 23** may be provided with a hub like hub **236** of **FIG. 22**.

[0126] Patches **212, 214, 216** may have any of a variety of shapes including square or rectangular (**FIGS. 21 and 22**), hexagonal (**FIG. 23**), triangular, octagonal, pentagonal, circular, oval, or other shape. A defect repair device like those disclosed in U.S. Pat. No. 5,334,217 to Das, which is incorporated herein by reference, may also be utilized in conjunction with the present invention.

[0127] **FIGS. 24A-24B** illustrate still another embodiment of defect repair device **130**. In this embodiment, defect repair device **130D** has a distal patch **244** of a flexible, biocompatible material attached to a wire frame **246**, much like distal patches **206, 208, 210** of **FIGS. 21-23**. Wire frame **246** may be continuous wire of stainless steel, Nitinol™, or other biocompatible, resilient metal or polymer, and may include a plurality of loops **248** like those shown in **FIGS. 21-23**. Rather than being attached to a proximal patch like the above-described embodiments, however, distal patch **244** of **FIG. 24** is attached to a central hub **250**, to which are coupled a plurality of radially-extending struts **252** on the proximal side of patch **244** and parallel thereto. While defect repair device **130D** is pictured with four such struts in **FIGS. 24A-24B**, struts **252** may be between three and twelve in number. Struts **252** are Nitinol, stainless steel, or other flexible, resilient biocompatible metal or polymer, and are coupled to hub **250** in such a way that the outer ends **254** of struts **252** are biased toward patch **244** and deflectable away from patch **244** about an axis perpendicular to the central axis of hub **250**. An additional patch (not shown) may be attached to struts **252** to provide patches on both sides of septum S, although in most cases, a single patch on the higher pressure side of the septum (the left side of the heart) is sufficient to prevent interatrial or interventricular blood flow through a septal defect.

[0128] In the embodiment shown, the inner ends **256** of struts **252** are formed in a loop which acts as a torsion spring to bias the struts toward patch **244**. Alternatively, inner ends **256** may be straight and anchored directly to hub **250**,

wherein each strut 252 acts as a leaf spring biased toward patch 244. Optionally, distal struts 260 coupled to hub 250 may be provided adjacent to or attached to patch 244, distally and parallel to struts 252, so as to compressively engage septum S between the two sets of struts, as shown in FIG. 24B. In the embodiment shown, each of struts 252 is formed with one of distal struts 260 from a single continuous length of wire, with a first loop at the inner end 256 of each strut 252, and a second loop at the inner end 262 of each distal strut 260. A retainer 261, which may be a snap-ring, band, or loop of suture, retains struts 252 and distal struts 260 on hub 250. Struts 252, 260 may be round in cross-section, or rectangular so as to increase the moment of inertia in the transverse direction so that the struts tend to bend only about an axis perpendicular to the central axis of hub 250. Outer ends 254, 264 of struts 252 and distal struts 260 may include a sharp point 258 oriented generally perpendicular to the straight portion of the strut so as to partially penetrate septum S, as shown in FIG. 24B. Points 258 may alternatively be made long enough so that the points completely penetrate septum S, allowing visual inspection of strut deployment by observing emergence of each point on the opposite side of the septum. In one embodiment, outer ends 254 are formed in a 270° loop so that points 258 attain a perpendicular orientation. Hub 250 includes a threaded hole 266 which may be coupled to an introducer shaft.

[0129] Defect repair device 130D of FIG. 24A is shown in FIG. 25A in a collapsed configuration within delivery shaft 134 for introduction into the heart through access device 22. Hub 250 is threadably mounted to a rod 273 attached to the end of an elongated tubular introducer shaft 268 to facilitate deployment of repair device 130D within the heart. Patch 244 and distal struts 260 are collapsed together distally of hub 250, while struts 252 are collapsed together proximally of hub 250. Spring loops at the inner ends 256, 262 of struts 252, 260 bias the struts outwardly against the inner wall of delivery shaft 134. A retraction wire 270, which may be a length of suture or wire, is attached to the outer end 254 of each strut 252 and extend through the interior of introducer shaft 268. After deployment of repair device 130D, retraction wires 270 may be used to retract the device back into delivery shaft 134 to reposition or remove the device. By tensioning retraction wires 270 from outside of the patient's body, struts 252 are re-collapsed and repair device 130 may be pulled back into delivery shaft 134. Preferably, retraction wires 270 are looped through outer ends 254 of the struts so that both ends of the retraction wires extend out of the body through delivery shaft 134. In this way, once repair device 130D is deployed satisfactorily, retraction wires 270 may be removed by simply pulling one end. Short lengths of suture or wire (not shown) may also be connected between outer ends 254 of adjacent pairs of struts 252, and a retraction wire 270 then looped through each short length. This configuration helps to maintain spacing between struts 252 and prevent tangling. Alternatively, a single retraction wire may extend through all of the loops at the outer ends of struts 252, with both ends of the single retraction wire extending out of the patient's body through delivery shaft 134.

[0130] FIG. 25B illustrates an exemplary embodiment of an actuator handle 249 mounted to a proximal end of delivery shaft 134 for deploying repair device 130D. Delivery shaft 134 is slidably received within an axial bore 251 in

a distal end of actuator handle 249. An actuator button 253 is slidably mounted to a post 255 attached to a proximal end of delivery shaft 134, and is biased outwardly by a spring 257. Button 253 extends through an axial channel 259 in actuator handle 249, and has an enlarged inner portion 263 which is slidably received within detents 265 at spaced-apart positions along channel 259. In this way, button 253 is locked in position when enlarged inner portion 263 is received in detents 265, and to move delivery shaft 134, button 253 is pushed inward and either proximally (to deploy repair device 130D) or distally (to retract repair device 130D). Detents 265 are positioned so as to correspond respectively with repair device 130D being fully retracted within delivery shaft 134, distal patch 244 being deployed from delivery shaft 134, and struts 252 being deployed from delivery shaft 134. Introducer shaft 268 extends out of the proximal end of delivery shaft 134 and is rotatably mounted to the proximal end of actuator handle 249. A rotatable knob 267 is mounted near the proximal end of introducer shaft 268 and is exposed through a slot 269 in the side of actuator handle 249 to allow rotation of introducer shaft 268 for decoupling from repair device 130D. Retraction wires 270 extend through the interior of introducer shaft 268 and extend out of actuator handle 249 through a hole 271 in the proximal end thereof.

[0131] FIGS. 26A and 26B illustrate the deployment of defect repair device 130D of FIGS. 24A-24B. Repair device 130D is delivered through access device 22 (not shown) into the heart in the collapsed configuration of FIG. 25 within delivery shaft 134. In the case of an atrial septal defect, delivery shaft 134 is introduced so that its distal end 136 is on the left atrial side of septum S, as shown in FIG. 26A. Introducer shaft 268 is then advanced distally relative to delivery shaft 134 until patch 244 is deployed from the distal end 136 of the delivery shaft. Upon deployment, distal struts 260 and/or frame 246 (not shown) of patch 244 spring outwardly to an expanded configuration in which patch 244 is generally flat and parallel to septum S within the left atrium. Delivery shaft 134 and introducer shaft 268 are then pulled proximally so that patch 244 engages septum S and points 258 on distal struts 260 penetrate into septum S. Delivery shaft 134 is then pulled further proximally relative to introducer shaft 268 so that struts 252 are deployed from delivery shaft 134, allowing them to spring outwardly and toward septum S, anchoring patch 244 in position as shown in FIG. 26B.

[0132] If the position of patch 244 is not satisfactory, retraction wires 270 may be tensioned to retract struts 252 back into delivery shaft 136. Introducer shaft 268 may then be pulled proximally to retract patch 244 back into the delivery shaft, or introducer shaft 268 may be pushed distally to disengage patch 244 from septum S, then manipulated to reposition the patch at the desired location. Struts 252 are then re-deployed in the manner described above. Once patch 244 is positioned satisfactorily on septum S, retraction wires 270 are removed from struts 252, introducer shaft 268 is decoupled from hub 250, and the introducer shaft and delivery shaft 134 are removed from the heart. Access device 22 is then removed from the heart, the penetration in the heart wall is closed, and the procedure completed as described above.

[0133] It should be noted that in any of the foregoing embodiments of defect repair device 130, a portion of the

patient's own pericardium may be excised and mounted to the frame or struts of the defect repair device as a patch. In an exemplary embodiment, endoscopic scissors and graspers are introduced through access ports 90 and used to cut and remove a portion of pericardium of suitable size to cover the septal defect. Exterior to the chest cavity, the pericardial patch is then sutured onto a wire frame similar to frames 224, 226, 228 of FIGS. 21-23, or onto struts like struts 252, 260 of FIGS. 24-26. If desired, two pericardial patches may be mounted to two frames or two sets of struts interconnected by a hub to provide patches on both sides of the cardiac septum. Once the pericardial patch is attached to the frame or struts, the defect repair device is introduced into the heart through access device 22 and attached to the cardiac septum as described above. Advantageously, the use of the patient's own pericardium reduces the risk of biologic incompatibility and other potential complications of artificial patch materials.

[0134] A further embodiment of a septal defect repair device according to the invention is shown in FIGS. 24C-24H. Referring to FIGS. 24C-D, repair device 130E comprises a distal patch 450 and a proximal patch 452 connected to a central hub 454. A plurality of struts 456 are connected at their inner ends to hub 454 and extend radially outward therefrom. Struts 456 may be between 2 and 20 in number, more usually between 3 and 12 in number, and preferably between 4 and 9 in number, depending upon the shape and size of patches 450, 452. In the particular embodiment illustrated, patches 450, 452 are generally septagonal, with seven of struts 456 extending outwardly from hub 454 to the apices of the septagon for each of the patches.

[0135] Patches 450, 452 are made of a flexible biocompatible material suitable for implantation in the heart and conducive to endothelialization. Expanded polytetrafluoroethylene, polyester, or other man-made materials may be used, as well as bovine or porcine tissue, or autologous tissue such as a piece of the patient's pericardium. In a preferred embodiment, patches 450, 452 each consist of two layers, with struts 456 sandwiched between the two layers. The two layers are then attached to one another to attach patches to the struts. In an exemplary embodiment, each patch 450, 452 has an underlayer 453 made of a knitted polyester material such as Bard Style 6103 cardiovascular material, 0.20 mm in thickness, and an outer layer 455 of polyester velour such as Bard Style 6108 cardiovascular material, 0.44 mm in thickness. The soft and porous velour surface of outer layer 455 is disposed on that side of each patch which faces outward toward the cardiac chamber so as to promote endothelialization over the exposed surface of the patch that comes into direct contact with blood. Inner layer 453 and outer layer 455 are then attached together using thermal or ultrasonic welding, a suitable biocompatible adhesive, sutures, staples or other appropriate fasteners. In a preferred embodiment, outer layer 455 is ultrasonically welded to inner layer 453 at a plurality of weld points 457 around the periphery of the layers and along each side of struts 456. Outer layer 455 is attached to hub 454 in the manner described below.

[0136] Struts 456 are preferably relatively stiff to support patches 450, 452 against the pressures of blood flow within the heart, being made of stainless steel, Nitinol, or other biocompatible metal or polymer. At the same time, struts 456 are collapsible into a configuration suitable for posi-

tioning delivery device 130E within delivery shaft 134, as shown in FIG. 24H. Preferably, a single continuous piece of wire is used to form two opposing struts 456A, 456B positionable on opposite sides of the cardiac septum. As shown in FIG. 24E, wherein patches 450, 452 have not yet been attached to the device, each of struts 456A, 456B has a coiled section 458 at its inner end that allows the strut to deflect about an axis perpendicular to the axis of hub 454. Struts 456A are preferably biased toward the opposing struts 456B, and vice versa, as shown in FIG. 24E, so as to compress the cardiac septum between the two sets of struts, firmly maintaining the position of the device in the heart. At the outer ends of the struts, an additional loop 460 is formed, and preferably, on at least one side of the cardiac septum, the ends 462 of struts 456 are sharpened and oriented generally orthogonal to the radial section of the strut (perpendicular to the plane of patch 452) so as to penetrate the cardiac septum to anchor the device in position. In some embodiments, all of struts 456 will have right-angled, sharpened ends 462 to penetrate the cardiac septum. Loops 460 serve not only as a convenient technique for forming ends 462 in a right-angled configuration, but further provide an eyelet through which a suture or retraction wire may be inserted for retracting the proximal patch 452 after initial deployment, as described below.

[0137] Hub 454, illustrated in FIGS. 24F-G, is preferably a rigid biocompatible metal or plastic suitable for implanting in the heart. Inner loops 458 of struts 456 are disposed in axial slots 464 in hub 454. Struts 456 are maintained on hub 454 by means of a retaining ring 466 disposed about hub 454 in a circumferential recess 468. Retaining ring 466 may consist of several wraps of suture material tied around hub 454, or a metallic wire or snap ring. A threaded bore 470 in one side of hub 454 facilitates attachment to a rod for deployment of the device, as described below. Hub 454 further includes a means for connecting each patch 450, 452 to the hub, preferably comprising a plurality of energy directors 472 extending axially from each end of the hub. In this embodiment, hub 454 is made of a plastic suitable for thermal or ultrasonic welding to patches 450, 452. When assembling repair device 130E, energy directors 472 are contacted by a thermal or ultrasonic welding head which melts and compresses the energy directors against the end of hub 454 to weld the energy directors to the patch material, thereby fastening outer layer 455 to hub 454.

[0138] FIG. 24H illustrates repair device 130E in a collapsed configuration within delivery shaft 134. The threaded distal end of inner control rod 268 is attached to hub 454, and a suture or other flexible retraction wire 270 is threaded through outer loops 460 of struts 456. Struts 456 of distal patch 450 are rotationally deflected away from struts 456 of proximal patch 452 until patches 450, 452 may be inserted into the inner lumen of delivery shaft 134, with outer ends 462 engaging the inner surface of delivery shaft 134. In this way, upon deployment of each patch from the delivery shaft, struts 456 will spring back toward their unbiased configuration, shown in FIG. 24E, thereby expanding the patch to its fully expanded configuration of FIG. 24C. If, following initial deployment, it is desired to retract repair device 130E back into delivery shaft 134, retraction wire 270 is tensioned, thereby re-collapsing proximal patch 452. Delivery shaft 134 is then advanced distally over proximal patch 452 and over distal patch 450, which collapses as it is engaged

by the delivery shaft. The device may then be repositioned and redeployed across the septal defect.

[0139] FIGS. 35A-D illustrate a visualization device and guide sleeve useful in connection with the septal defect repair devices of the invention. As shown in FIG. 35A, a contact scope 400 includes a tubular sheath 402 having a transparent bulb 404 of glass or a clear plastic such as acrylic, polystyrene, or polycarbonate at its distal end. Bulb 404 has a convex distal surface 406 configured to provide a wide-angle view distally through bulb 404. An axial lumen 408 extends through sheath 402 and terminates within or just proximal to bulb 404. A pair of flanges 410, 412 are disposed at the proximal end of sheath 402 and are spaced axially apart from each other for reasons described below. Alternatively, bulb 404 may be an expandable balloon in communication with an inflation lumen extending through sheath 402, similar to that described above in connection with FIG. 8B.

[0140] Axial lumen 408 is dimensioned to receive an endoscope or thoracoscope 414, which may be any of a variety of commercially-available endoscopes or thorascopes, such as those described above in connection with FIG. 8B. Shaft 416 of thoracoscope 414 is inserted into lumen 408 and distal end 418 advanced up to the distal end of lumen 408, enabling the user to look through eyepiece 420 and view the body cavity through bulb 404. Optionally, a video camera may be connected to eyepiece 420 to allow the user to view the body cavity on a video monitor. A fiber optic connector 422 is also provided to facilitate connection of a light source which transmits light into the body cavity through optical fibers (not shown) extending longitudinally through shaft 416. In other embodiments, bulb 404 may be mounted directly to the distal end of thoracoscope 414, eliminating the need for separate sheath 402. Bulb 404 serves not only to provide a wide-angle view through thoracoscope 414, but further to displace blood away from the distal end of the thoracoscope to facilitate visualization within the blood-filled heart. Bulb 404 may be placed against the surface of the septum, and manipulated to identify the location of a septal defect.

[0141] FIG. 35B illustrates a guide sleeve 424 useful in conjunction with contact scope 400 to maintain contact with a septal defect once located. Guide sleeve 424 comprises a tubular shaft 426 preferably constructed of a fairly rigid material such as stainless steel or a rigid biocompatible polymer. A longitudinal channel 428 extends through shaft 426 and is configured to removably receive contact scope 400 such that bulb 404 may be positioned at the distal end 430 of shaft 426 with convex surface 406 protruding distally therefrom, as illustrated in FIG. 35C. In an exemplary embodiment, tubular shaft 426 is about 15-30 cm in length for adult use, about 10-20 cm for pediatric use, with an outer diameter of about 7-12 mm and an inner diameter of about 5-10 mm. A flange 432 is provided at the proximal end of shaft 426 which contacts flange 410 when contact scope 400 is properly positioned in guide sleeve 424. Because sheath 402 has sufficient length to extend over the full length of shaft 416 of endoscope 414, the axial spacing of flange 412 apart from flange 410 is selected to position the distal end of guide sleeve 424 proximate to the distal end of sheath 402 when the proximal end of the guide sleeve is against flange 410.

[0142] The use of contact scope 400 and guide sleeve 424 is illustrated in FIGS. 36A-36E. As shown in FIG. 36A, access device 22 is introduced through a trocar sleeve 90 and into the atrium or ventricle through an outer wall of the heart H in the manner described above. A purse string suture serves to seal the penetration in the wall of the heart to prevent blood loss. Thoracoscope 414 is inserted into contact scope 400 which is inserted into guide sleeve 424, and the assembly is introduced through access device 22 into the heart. The user may view the interior of the heart through eyepiece 420 and bulb 404 to locate the septal defect to be repaired. Usually bulb 404 will be placed in contact with the cardiac septum and manipulated until the defect is found. Once the defect is located, guide sleeve 424 is advanced distally until its distal end 430 is positioned through the septal defect D, as shown in FIG. 36B. Contact scope 400 and thoracoscope 414 are then removed from guide sleeve 424.

[0143] By positioning guide sleeve 424 in septal defect D, the user maintains contact with the defect and can relocate it easily without repeated use of contact scope 400. A defect repair device may then be inserted through guide sleeve 424 and used to close the defect. FIGS. 36C-E illustrate the placement of a patch-type defect repair device 130E like that described above with reference to FIGS. 24C-H. Delivery shaft 134 is inserted through guide sleeve 424 so that its distal end is positioned through defect D, as shown in FIG. 36C. Guide sleeve 424 may then be retracted proximally relative to delivery shaft 134. Actuator button 253 on handle 249 is then slid proximally so as to deploy distal patch 450 on that side of the defect further away from the user, shown in FIG. 36D. Handle 249 is then manipulated to bring distal patch 450 in contact with the septum around defect D. Actuator button is slid further proximally along handle 249 to deploy proximal patch 452.

[0144] At this point, patch placement can be checked by removing delivery shaft 134 while leaving control rod 268 and the retraction wire or suture (not shown in FIG. 36E) connected to repair device 130E. Contact scope 400 and thoracoscope 414 may be reinserted through guide sleeve 424 to inspect placement of the repair device. If repositioning is desired, delivery shaft 134 may be reinserted through guide sleeve 424 and repair device 130E retracted into the delivery shaft for redeployment. If placement is satisfactory, control rod 268 is decoupled from repair device 130E and delivery shaft 134 removed from the heart. Guide sleeve 424 is removed from access device 22, and the procedure completed as described above.

[0145] It will be understood that, while contact scope 400 and guide sleeve 424 have been described in conjunction with defect repair device 130E, the contact scope and guide sleeve of the invention will be useful with any of the defect repair devices described herein, including other configurations of patch-type devices as well as the suture-based closure devices described below.

[0146] In another embodiment of the invention, illustrated in FIGS. 27-33, an apparatus and method are provided for closure of septal defects using sutures, rather than patch-type defect repair devices. In this embodiment, a plurality of needles 274 are mounted to a distal end 276 of an introducer shaft 278. Needles 274 are held parallel to introducer shaft 278 in a generally circular arrangement coaxial with the

introducer shaft. Needles 274 may be between 2 and 12 in number, and preferably are 4, 6, or 8 in number, depending upon the size of the defect to be closed. A length of suture thread 275 (best seen in FIG. 28) extends between each pair of needles 274, each pair having one needle on opposite sides of an imaginary line separating needles 274 into two equal groups.

[0147] Introducer shaft 278 is preferably a rigid material such as stainless steel for optimum control in manipulating and positioning needles 274 from outside of the chest cavity. Alternatively, all or a distal portion of introducer shaft 278 may be a flexible material and may include means for deflecting or steering distal end 276, such as pull wires anchored internally to distal end 276 and extending through the introducer shaft to an actuator at the proximal end for selectively tensioning the pull wires. Introducer shaft 278 may be used to introduce needles 274 through access device 22 into the right atrium RA, and through septal defect D into left atrium LA, as illustrated in FIG. 27. Needles 274 have sharp distal tips 280 oriented so as to point in a proximal direction toward septum S from left atrium LA, and are held removably at their proximal ends 282 in needle holders 284 extending distally from the distal end of introducer shaft 278. Needle holders 284 comprise flexible rods of stainless steel, titanium, Nitinol® (Raychem Corp.), or a biocompatible polymer, having a needle holding cup 285 (seen more clearly in FIGS. 28-29) at their distal ends in which needles 274 are inserted.

[0148] An expandable element 286 is disposed concentrically within the space surrounded by needles 274 distal to introducer shaft 278. Expandable element 286 may comprise an inflatable balloon having an interior in communication with an inflation tube 288 extending through an inner lumen in introducer shaft 278. Alternatively, expandable element 286 may comprise a rigid camming element such as a disk, cylinder, or ball fixed to the end of a movable shaft 288.

[0149] As illustrated in FIG. 28, expandable element 286 is expanded by, e.g., introducing an inflation fluid through inflation tube 288. Expandable member 286 urges needle holders 284 outward so that distal tips 280 are pointed toward septum S around the periphery of defect D.

[0150] With needle holders 284 in a radially-expanded position, introducer shaft 278 is drawn proximally relative to access device 22 so that needle distal tips 280 penetrate septum S, as shown in FIGS. 29A-29B. It can be seen that cups 285 on needle holders 284 are held in an offset relationship to flexible rods 287 so that when rods 285 engage septum S at the periphery of defect D, needles 274 are spaced outwardly a predetermined distance from the edge of the defect to ensure adequate spacing and "bite" on the septal tissue. Preferably, each needle 274 penetrates septum S about 1-3 mm from the edge of defect D.

[0151] As best seen in FIG. 29B, introducer shaft 278 may comprise a plurality of axial tubes 290 in which needle holders 284 are disposed. Needle holders 284 are slidable within tubes 290 so that needles 274 may be moved proximally relative to tubes 290 until distal tips 280 enter the open distal ends 292 of tubes 290. A distal portion of tubes 290 may be flared or widened to facilitate receiving needles 274. A means for capturing needles 274 (not shown) is provided within tubes 290 near distal ends 292, such as a porous mesh or screen of a biocompatible material such as Gore-Tex®,

cotton, or Dacron, which may be penetrated by distal tips 280 of needles 274. A barb 294 is provided on needles 274 just proximal to distal tips 280 which may be caught in the needle capturing means within tubes 290 to retain needles 274 therein. Once needles 274 are captured within tubes 290, introducer shaft 278 is drawn proximally relative to needle holders 284, pulling needles 274 through septum S. Expandable member 286 may then be deflated, and expandable member 286 along with needle holders 284 are then pulled proximally through defect D. Introducer shaft 278 (to which needles 274 are attached at distal ends 290), introducer shaft 278, and inflation tube 288 are then withdrawn from the heart through access device 22.

[0152] In an alternative embodiment, illustrated in FIGS. 30A-30B, the means for capturing needles 290 comprises an outer sleeve 296 slidably disposed over introducer shaft 278. Outer sleeve 296 has a capture disk 298 on its distal end which has a penetrable outer layer 300 comprising a porous mesh, sponge, or screen of a biocompatible material such as Gore-Tex®, cotton, or Dacron. To capture needles 274, as shown in FIG. 30A, expandable member 286 is deflated, and outer sleeve 296 is slid distally over introducer shaft 278 until distal tips 280 of needles 274 penetrate outer layer 300 of capture disk 298. Barbs 294 are caught in the porous material of outer layer 300. Outer sleeve 296 may then be drawn proximally relative to introducer shaft 278 as shown in FIG. 30B, pulling needles 274 through septum S. Expandable member 286 and needle holders 284 are then withdrawn through defect D. Outer sleeve 296 (to which needles 274 are attached), introducer shaft 278, and inflation tube 288 are then withdrawn from the heart through access device 22.

[0153] Capture disk 298 may be a flexible foam or solid material such as natural or synthetic rubber (e.g. silicone), thermoplastic elastomer, or polyurethane so as to be collapsible for introduction and removal from the heart through access device 22. Alternatively, capture disk 298 may be an expandable member such as an inflatable balloon or expandable basket which allows introduction and removal through access device 22 in a collapsed state, and expansion into an expanded state within the heart for capturing needles 274. In either case, capture disk 298 has sufficient rigidity when expanded to allow needles 274 to penetrate outer layer 300 without the capture disk over-flexing or collapsing.

[0154] As a further alternative technique for capturing needles 274 after they have penetrated septum S, needles 274 are removed from cups 285 by pushing distally on needle holders 284. Expandable member 286 is then deflated and withdrawn through defect D along with needle holders 284. Introducer shaft 278, inflation tube 288 and needle holders 284 are then withdrawn from the heart through access device 22, leaving needles 274 extending through septum S. An elongated endoscopic needle driver (not shown) may then be introduced through access device 22 into the heart, and, under visualization with ultrasound, an endoscope, or fluoroscope, the needle driver is used to grasp each needle 274 and pull it through septum S and out of the heart through access device 22.

[0155] When needles 274 have been withdrawn from the heart, at least one, and usually two to six loops of suture (depending upon the number of needle pairs used), will have been formed across defect D, as illustrated in FIGS. 31A-

31B. Suture threads **275** are long enough, usually at least about 30 cm in length, to extend across defect D and through septum S, with both ends extending out of the heart and chest cavity through access device **22**. In this way, sutures **275** may be tensioned to draw defect D closed, and knots formed extracorporeally and pushed into the heart through access device **22** using an elongated endoscopic knot pusher. As shown in **FIG. 31C**, a plurality of knots **304** are formed in each suture **275** and pushed against septum S to ensure tight closure of defect D. Sutures **275** are then trimmed using elongated endoscopic scissors introduced through access device **22**. Complete closure and absence of shunting is verified using transesophageal echocardiography or one of the other visualization techniques outlined above.

[**0156**] An alternative embodiment of a septal defect repair device according to the invention is illustrated in **FIGS. 32A-32D**. This embodiment of defect repair device **130** is in many respects similar to that described above in connection with **FIGS. 27-30**, the major difference being that needle holders **284** are pre-shaped so as to be biased outward into the radially-expanded configuration shown in **FIG. 32B**. Needle holders **284** may be stainless steel, a shape-memory alloy such as nickel-titanium, or another flexible and resilient metal or polymer. Needle holders **284** may be long enough to extend entirely out of the body cavity through access device **22**, or they may be attached to an introducer shaft (not shown) as in the above embodiments. As shown in **FIG. 32A**, a restraining sleeve **306** is slidably positioned over needle holders **284** and may be advanced distally relative to the needle holders to urge needle holders **284** inward into a collapsed position for introduction through access device **22** and through defect D. A distal portion of needle holders **284** is pre-shaped in an outward bend or curve so that, when restraining sleeve **306** is retracted, needle holders **284** return to a radially-expanded position in which needles **274** are positioned outside of a circle defined by the diameter of defect D. As in previous embodiments, needle holding cups **285** are offset relative to rods **287** of needle holders **284** so that needle holders **284** move outward until rods **287** engage septum S at the periphery of defect D. Needles **274** are then positioned at a predetermined spacing from the edge of defect D to ensure adequate "bite" into septal tissue.

[**0157**] The embodiment of the defect repair device of **FIGS. 32A-32D** is otherwise similar to the embodiments of **FIGS. 27-31** described above. As shown in **FIGS. 32C-32D**, after needles **274** have been drawn through septum S around defect D, the needles are captured by means of a capture disk **298** with a porous outer layer **300**, or by another means such as endoscopic needle drivers introduced through access device **22**, as described above. After capture of needles **274**, restraining sleeve **306** is advanced distally to collapse needle holders **284** inward, and needle holders **284**, restraining sleeve **306**, capture disk **298**, and needles **274** are withdrawn from the heart through access device **22**. This leaves sutures **275** extending across defect D as shown in **FIGS. 31A-31B**; sutures **275** are then tensioned, knots are formed in sutures **275** extracorporeally, and the knots are pushed into the heart and against septum S using an endoscopic knot pusher, closing defect D as illustrated in **FIG. 31C**. A suitable knot pusher is disclosed in copending application Ser. No. 08/288,674, entitled "Surgical Knot Pusher and Method of Use," filed Aug. 10, 1994, the disclosure of which is hereby incorporated herein by reference.

[**0158**] It should be noted that while the method of the invention has been described in connection with the repair of atrial septal defects, it will be understood to those of ordinary skill in the art that the invention will be equally applicable to repair of ventricular septal defects, patent ductus arteriosus, and other defects of the heart. Access device **22** may also be introduced through a wall of the right ventricle, left atrium, pulmonary artery, or pulmonary vein rather than the right atrium. Alternatively, access device **22** may be introduced into the right atrium as previously described, with access to the right ventricle or pulmonary artery obtained from the right atrium through the tricuspid valve. Devices and techniques similar to those described above for atrial septal defects may be used for repairing ventricular defects and patent ductus arteriosus. Other repair devices designed specifically for ventricular septal defects and patent ductus arteriosus which are useful in the method of the present invention are described in U.S. Pat. No. 3,874,388, which has been incorporated herein by reference. The defect repair devices of the invention may also be used to repair the penetration in the heart wall made by access device **22**, and to repair other types of defects, holes, incisions, or punctures in other organs and tissue structures.

[**0159**] In addition to repair of atrial and ventricular septal defects and patent ductus arteriosus, the devices and methods of the invention also facilitate various other intracardiac interventions, including electrophysiological mapping and ablation. **FIGS. 33 and 34** illustrate two embodiments of an electrophysiological device according to the invention. In the embodiment of **FIG. 33**, an electrophysiology device **310** is introduced through access device **22** into a chamber C of the heart H. Electrophysiology device **310** includes a rigid shaft **312** having a distal end **314** and a proximal end **316**. Usually, at least one inner lumen (not shown in **FIG. 33**) extends through shaft **312** between distal end **314** and proximal end **316**. A flexible and pre-shaped or deflectable tip **318** is attached to distal end **314**. A handle **320** is attached to proximal end **316**. A plurality of conductive electrode bands **322** are mounted to deflectable tip **318**, each electrode band being separately electrically coupled by means of wires (not shown) within shaft **312** to a connector **324** on handle **320**. Connector **324** is adapted to be coupled to a cord **326** which is connected to a radiofrequency generator or electrocardiography machine (not shown) used in conventional mapping and ablation procedures. An actuator **328** is slidably coupled to handle **320** and is connected to deflectable tip **318** by at least one pull wire (not shown) extending slidably through an inner lumen in shaft **312** and attached internally to deflectable tip **318** near its distal end **330**. In this way, sliding actuator **328** proximally on handle **320** deflects deflectable tip **318** into a curved configuration, as illustrated in **FIG. 33**. Of course, various types of actuators may be used for deflection of deflectable tip **318**, including shapable or deflectable handles, joy-sticks, levers, pistol grips, and the like. In addition, shaft **312** may be rotatably coupled to handle **320**, and a rotator knob (not shown) may be attached to shaft **312** near proximal end **316** to allow deflectable tip **318** to be rotated about the longitudinal axis of shaft **312**. Exemplary mechanisms for actuation and deflection of deflectable tip **318** and other features which may be incorporated into electrophysiology device **310** are disclosed in U.S. Pat. Nos. 4,960,134, 5,318,525, 5,368,592, 5,364,351, and 5,313,943, which are incorporated herein by reference. While these patents disclose highly flexible, endovascular

electrophysiology catheters for introduction transluminally from a peripheral vessel into the heart, it will be understood to those of ordinary skill in the art that any of the features of endovascular electrophysiology devices may be easily incorporated into the more rigid, thoracoscopic electrophysiology device of the invention.

[0160] Shaft **312** has a length which is long enough to extend from within chamber C of heart H through access device **22** outside of the patient, usually being 20-30 cm in length. Shaft **312** is preferably rigid, usually being made of stainless steel (with insulated electrodes and wires) or of a rigid biocompatible polymer, so as to facilitate precise and controllable positioning of deflectable tip **318** from outside of the chest cavity using handle **320**. Deflectable tip **318** is a non-conductive, flexible and biocompatible polymer such as polyurethane, silicone, thermoplastic elastomer, polyolefin, polyamide, or a fluoropolymer.

[0161] In an alternative embodiment, illustrated in **FIG. 34**, electrophysiology device **310** includes, rather than a deflectable tip **318** as in the previous embodiment, an expandable electrode array **332** attached to distal end **314** of shaft **312**. In a preferred embodiment, electrode array **332** comprises a plurality of electrode bands **334** mounted in spaced-apart positions to an expandable basket **336**. Expandable basket **336** includes a plurality of axially-oriented beams **338**, which are preferably a non-conductive, flexible and resilient polymer such as a polyolefin or polyamide, or a metal such as stainless steel or nickel-titanium alloy with an insulative coating to electrically isolate each of electrode bands **334**. Beams **338** are coupled together at their distal ends **340**, and at their proximal ends are attached to shaft **312**. In one embodiment, shaft **312** is a polymeric tubular extrusion, and beams **338** are formed integrally with shaft **312** as part of the same extrusion, by, for example cutting axial slits in a distal portion of shaft **312**. As in the embodiment of **FIG. 33**, each of electrode bands **334** is independently electrically coupled to connector **324** by a wire extending through an inner lumen in shaft **312**.

[0162] Expandable basket **336** is movable between a collapsed configuration suitable for introduction through access device **22** and an expanded configuration in which electrode bands **334** are spread apart into a three-dimensional array, positioned at various distances both radially outward from and distal to shaft **312**, as shown in **FIG. 34**. In this way, electrode bands **334** may be simultaneously positioned at a number of locations around the interior wall of chamber C. To move expandable basket **336** between the collapsed and expanded configurations, a variety of different mechanisms may be utilized. In one embodiment, a pull wire **342** is coupled to distal ends **340** of beams **338**, and extends slidably through a lumen in shaft **312** for attachment to actuator **328**. In this way, actuator **328** may be slid in a proximal direction to exert a compressive force on beams **338**, causing beams **338** to bow outward into the expanded configuration. When pressure is released from actuator **328**, beams **338** recoil to their unstressed, straight configuration.

[0163] In addition to the embodiment illustrated, various types of structures may be used for electrode array **332**, including those disclosed in U.S. Pat. Nos. 4,699,147, 4,660,571, 4,628,937, 4,522,212, 5,313,943, and 5,327,889, which are incorporated herein by reference. Although these patents describe endovascular electrophysiological catheters, it will

be understood to those of ordinary skill in the art that the electrode array configurations, structures and deployment mechanisms disclosed may be easily adapted to the larger diameter, shorter and more rigid thoracoscopic electrophysiology device of the present invention.

[0164] Electrophysiology device **310** may be used for either mapping or ablation of conduction pathways in the heart. In use, electrophysiology device **310** is introduced into chamber C of heart H through inner lumen **30** of access device **22**. Chamber C may be the left or right ventricle, or left or right atrium, depending upon where the target site for mapping or ablation is located. If the target site is in the higher pressure left side of the heart, access device **22** is provided with a hemostasis seal in inner lumen **30** to allow introduction of electrophysiology device **310** without significant leakage of blood. For the device of **FIG. 33**, deflectable tip **318** is substantially straight and undeflected during introduction. For the device of **FIG. 34**, expandable basket **336** is in a collapsed state in which beams **338** are substantially straight and aligned with shaft **312** during introduction. Once introduced into chamber C, deflectable tip **318** is deflected (in the embodiment of **FIG. 33**) or expandable basket **336** is expanded into an expanded configuration (in the embodiment of **FIG. 34**) by sliding actuator **328** on handle **320**. Under visualization using transthoracic echocardiography or one of the other techniques described above, electrodes **322**, **334** are positioned at the desired location against the wall of chamber C by manipulating the device with handle **320**. The relatively short distance between the user and the interior of chamber C, as well as the rigidity of shaft **312**, facilitate exceptionally controllable and precise manipulation of the device relative to endovascular catheter-based electrophysiology devices.

[0165] When electrodes **322**, **334** have been positioned at the desired site in chamber C, conduction pathways can be mapped by measuring the electrical potential between selected electrodes with sensitive electrocardiographic equipment. When aberrant pathways are found, they may be ablated by applying radiofrequency current from a radiofrequency generator through a selected electrode or electrodes on electrophysiology device **310** to the myocardial tissue. These techniques may be used to diagnose and/or treat ventricular tachycardias, ventricular fibrillation, supraventricular tachycardias such as Wolff-Parkinson-White Syndrome, atrial fibrillation, and other conduction-related diseases. Ablation may also be performed using a medical laser transmitted through an optical fiber introduced into the heart through access device **22**, by techniques analogous to the endovascular laser ablation techniques disclosed in U.S. Pat. No. 5,104,393, which is incorporated herein by reference.

[0166] In addition, thoracoscopic, endovascular, or open surgical devices and techniques may be used in conjunction with the devices and methods of the present invention. For example, electrophysiology device **310** may be used to ablate selected cardiac tissue within the heart based on mapping information generated using endovascular mapping catheters or thoracoscopic mapping devices. Alternatively, electrophysiology device **310** may be used for mapping conduction pathways in the heart, which are then treated by means of thoracoscopic, endovascular, or open-chest techniques. Such a technique could be used for treatment of ventricular and supraventricular tachycardias. Simi-

larly, to treat atrial fibrillation, after intracardiac mapping has been performed using the electrophysiology device of the invention and/or endovascular mapping techniques, mechanical, laser, or RF cutting devices may be introduced through access device **22**, and precise incisions or ablation lines may be made in the myocardium to create a directed conduction pathway between the sinoatrial node and the atrioventricular node to perform a Cox "maze" procedure.

[0167] After the electrophysiology procedure is completed, deflectable tip **318** is returned to its straightened configuration or expandable basket **336** is collapsed so that beams **338** are again straight and aligned with shaft **312**. Electrophysiology device **310** is then removed from the chest cavity through access device **22**.

[0168] In addition to repair of atrial and ventricular septal defects and cardiac mapping and ablation, the devices and techniques of the invention are useful in a variety of other intracardiac procedures. Low-profile, elongated instruments may be introduced through access device **22** to inspect and repair the mitral, tricuspid, pulmonary or aortic valves. Commissurotomy may be performed, for example, by introducing a cutting instrument and incising the valve commissures to separate the valve leaflets. A collapsible valve prosthesis, such as those described in U.S. Pat. No. 5,370,685, or 5,411,552, which are incorporated herein by reference, could be introduced into the heart through access device **22** to replace a diseased heart valve. Transmyocardial laser revascularization may be performed by introducing a laser-transmitting optical fiber through access device **22** and using the laser to drill new blood-carrying conduits into the myocardium from within the heart chambers. Cutters, graspers, biters, and the like may be introduced through access device **22** to cut and remove unwanted tissue or other material from the heart and great vessels, such as thrombus (e.g. pulmonary thrombectomy), myxomas, neoplasms, vegetations, calcifications, and tissues affected by hypertrophic obstructive cardiomyopathy. Catheters may also be introduced through access device **22** for positioning in the pulmonary artery, coronary sinus, or other locations for perfusion, drug delivery, fluid venting, and other purposes. Advantageously, many of these procedures can be performed while the heart is beating, without the need to place the patient on cardiopulmonary bypass and to induce cardioplegic arrest. In addition, these procedures can be performed without the need for a median sternotomy or other gross thoracotomy, reducing greatly the pain, recovery time, morbidity, and mortality associated with open heart surgery.

[0169] While the above is a complete description of the preferred embodiments of the invention, it will be understood to one of ordinary skill in the art that certain modifications, substitutions, improvements and additions may be made without departing from the scope thereof, which is defined by the appended claims.

What is claimed is:

1. An assembly for visualization and access within a body cavity comprising:

a sleeve having a distal end, a proximal end, and a lumen therebetween;

a scope having a shaft with a distal end and a proximal end, the shaft being slidably positionable in the lumen,

a channel extending longitudinally through the shaft, and a lens in the channel near the distal end,

a transparent bulb disposed at the distal end of the shaft outside of the channel and optically aligned with the lens.

2. The assembly of claim 1 wherein the transparent bulb is mounted to the distal end of the shaft.

3. The assembly of claim 1 wherein the transparent bulb is mounted to an elongate sheath having a proximal end, a distal end, and a lumen therebetween, the shaft being positionable in the lumen with the distal end of the shaft adjacent to the bulb.

4. The assembly of claim 1 wherein the transparent bulb is substantially rigid.

5. The assembly of claim 1 wherein the transparent bulb is made of a material selected from glass, acrylic, polystyrene, and polycarbonate.

6. The assembly of claim 1 wherein the transparent bulb has a transverse cross-sectional area larger than the transverse cross-sectional area of the shaft.

7. The assembly of claim 1 wherein the transparent bulb has a distal surface, the distal surface being convex.

8. The assembly of claim 1 wherein sleeve has a length sufficient to reach an interior of a patient's heart from outside the patient's chest.

9. The assembly of claim 8 wherein the sleeve has a length of at least about 15 cm.

10. The assembly of claim 1 wherein the transparent bulb comprises an expandable member, the assembly further comprising an inflation lumen in communication with the expandable member for delivering an inflation fluid thereto.

11. The assembly of claim 1 wherein the sleeve is substantially rigid.

12. A contact scope for visualization within a body cavity comprising:

an elongate sheath having a distal end, a proximal end, a lumen therebetween, and a transparent bulb mounted to the distal end aligned with the lumen; and

a scope slidably positionable in the lumen, the scope having a shaft with a distal end, a proximal end and a channel therebetween, and a lens mounted in the channel near the distal end;

wherein the distal end of the shaft may be positioned within the lumen adjacent to the transparent bulb to allow viewing through the lens and the bulb.

13. The contact scope of claim 12 wherein the transparent bulb is substantially rigid.

14. The contact scope of claim 12 wherein the transparent bulb is made of a material selected from glass, acrylic, polystyrene, and polycarbonate.

15. The contact scope of claim 12 wherein the transparent bulb has a transverse cross-sectional area larger than the transverse cross-sectional area of the shaft.

16. The contact scope of claim 12 wherein the transparent bulb has a distal surface, the distal surface being convex.

17. The contact scope of claim 12 wherein the transparent bulb comprises an expandable member, the sheath further comprising an inflation lumen in communication with the expandable member for delivering an inflation fluid thereto.

18. The contact scope of claim 12 further comprising a sleeve having an axial lumen, the sheath being removably positionable in the axial lumen.

19. A repair system for repairing a septal defect in a patient's heart, the repair system comprising:

a sleeve having a distal end, a proximal end, and a lumen therebetween;

a scope having a shaft with a distal end and a proximal end, the shaft being slidably positionable in the lumen, a channel extending longitudinally through the shaft, and a lens in the channel near the distal end,

a transparent bulb disposed at the distal end of the shaft optically aligned with the lens; and

a septal defect closure device positionable through the lumen of the sleeve.

20. The repair system of claim 19 wherein the septal defect closure device comprises a delivery shaft having a distal end, a proximal end, and a patch releasably held at the distal end, the patch having a deployed configuration for positioning across a septal defect and a collapsed configuration for positioning through the lumen in the sleeve.

21. The repair system of claim 19 wherein the septal defect closure device is configured to apply a suture to the cardiac septum.

22. The repair system of claim 19 wherein the transparent bulb is mounted to the distal end of the shaft.

23. The repair system of claim 19 wherein the transparent bulb is mounted to an elongate sheath having a proximal end, a distal end, and a lumen therebetween, the shaft being positionable in the lumen with the distal end of the shaft adjacent to the bulb.

24. The repair system of claim 19 wherein the transparent bulb is substantially rigid.

25. The repair system of claim 19 wherein the transparent bulb comprises an expandable member, the assembly further comprising an inflation lumen in communication with the expandable member for delivering an inflation fluid thereto.

26. The repair system of claim 19 wherein the transparent bulb has a transverse cross-sectional area larger than the transverse cross-sectional area of the shaft.

27. The repair system of claim 19 wherein the transparent bulb has a distal surface, the distal surface being convex.

28. The repair system of claim 19 wherein sleeve has a length sufficient to reach an interior of a patient's heart from outside the patient's chest.

29. The repair system of claim 28 wherein the sleeve has a length of at least about 15 cm.

30. The repair system of claim 19 wherein the sleeve has an outer diameter of less than about 12 mm.

31. The repair system of claim 19 wherein the sleeve is substantially rigid.

32. The repair system of claim 19 further comprising an access cannula having a distal end positionable through a wall of the heart, a proximal end, and an access channel therebetween, the sleeve being slidably positionable through the access channel into the heart.

33. The repair system of claim 32 wherein the access cannula has a flange on a distal end thereof for engaging an interior wall of the heart.

34. The repairs system of claim 32 further comprising an obturator removably positionable in the access channel.

35. The repair system of claim 34 wherein the obturator has a distal end configured to penetrate the wall of the heart.

36. A method of locating an opening in a patient's heart, comprising:

positioning a visualization scope through a sleeve;

positioning a distal end of the visualization scope into the heart through a penetration in a wall thereof;

viewing the opening through the visualization scope;

sliding the sleeve into the opening; and

removing the visualization scope from the sleeve.

37. The method of claim 36 further comprising the steps of:

positioning the visualization scope in a sheath outside the heart such that a distal end of the visualization scope is adjacent to a transparent bulb on a distal end of the sheath; and

positioning the sheath in the heart through the sleeve;

viewing the opening through the transparent bulb.

38. The method of claim 36 further comprising:

positioning a repair device through the sleeve while the sleeve is positioned through the opening; and

closing the opening with the repair device.

39. The method of claim 38 wherein the repair device comprises a patch which is secured across the opening.

40. The method of claim 36 wherein the visualization scope and the sleeve are positioned through an access cannula extending from outside the chest through the penetration in the wall of the heart.

41. The method of claim 36 wherein the heart remains beating during each of said steps.

42. The method of claim 36 wherein the opening comprises a septal defect.

* * * * *