



(19) **United States**

(12) **Patent Application Publication**
Sullivan et al.

(10) **Pub. No.: US 2004/0020206 A1**

(43) **Pub. Date: Feb. 5, 2004**

(54) **HEAT ENERGY UTILIZATION SYSTEM**

(52) **U.S. Cl. 60/670**

(76) **Inventors: Timothy J. Sullivan, Dublin, OH (US);
William T. Hanna, Gahanna, OH (US);
Donald Anson, Worthington, OH (US);
David A. Ball, Westerville, OH (US)**

(57) **ABSTRACT**

Correspondence Address:
Killworth, Gottman, Hagan & Schaeff, L.L.P.
Suite 500
One Dayton Centre
Dayton, OH 45402-2023 (US)

A power generation system includes a prime mover subsystem and a Rankine-cycle heat energy utilization subsystem. The waste heat stream from the prime mover subsystem provides sufficient thermal content to power the heat energy utilization subsystem. The heat energy utilization subsystem can include a hermetically sealed scroll device, which can expand the working fluid through a single or dual scroll pair configuration. The heat energy utilization subsystem may also include a load-splitting controller, quick-start features and a capacity control module to facilitate rapid response to variable load conditions, as well as provide stand-alone operational capability. The load-splitting controller may incorporate a fuzzy logic controller to coordinate operation between the two subsystems. Energy generated by the heat energy utilization subsystem can be in the form of heat for various domestic and process needs, or can provide supplemental electric current.

(21) **Appl. No.: 10/139,988**

(22) **Filed: May 7, 2002**

Related U.S. Application Data

(60) **Provisional application No. 60/289,072, filed on May 7, 2001.**

Publication Classification

(51) **Int. Cl.⁷ F01K 13/00; F01K 1/00**

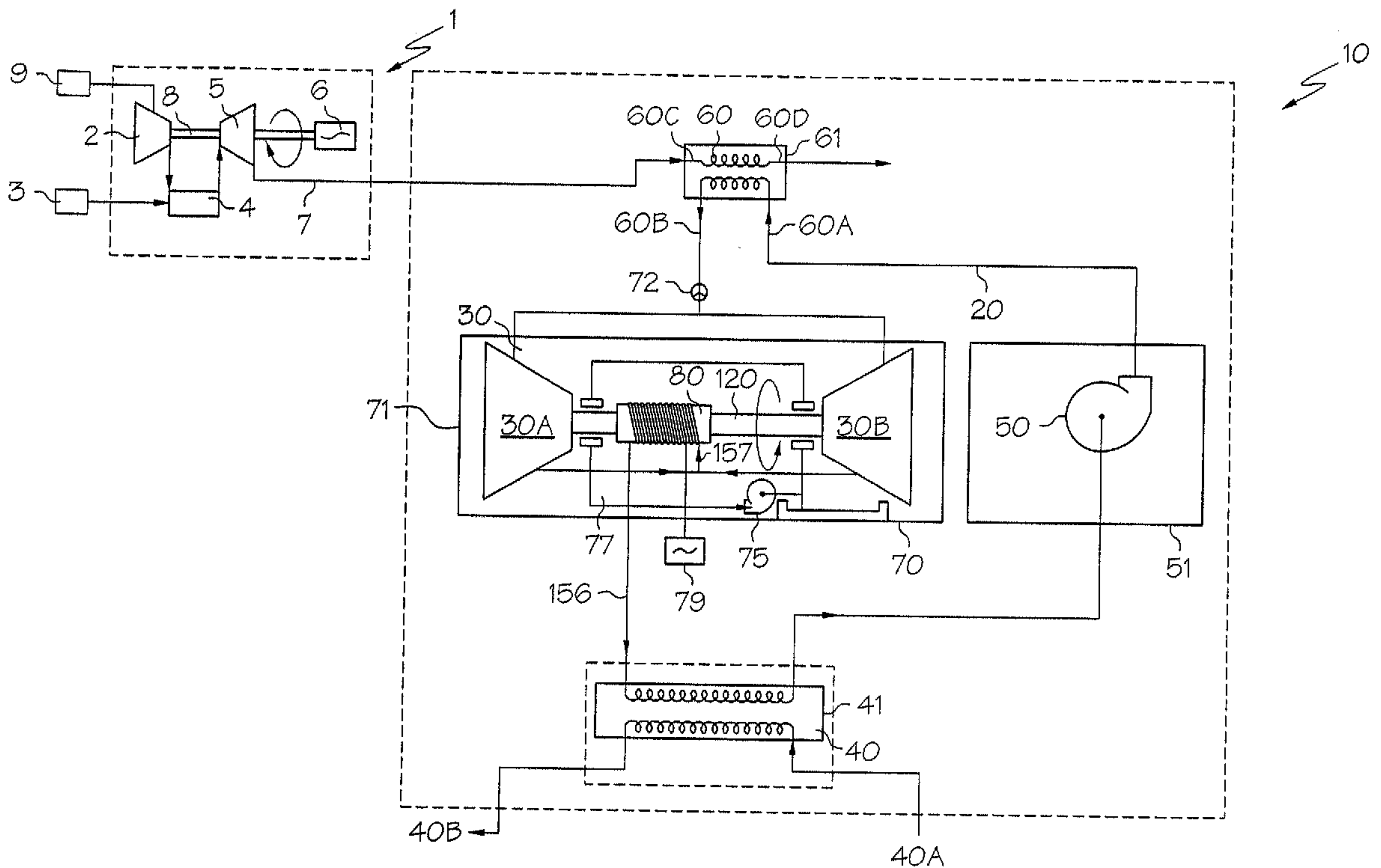

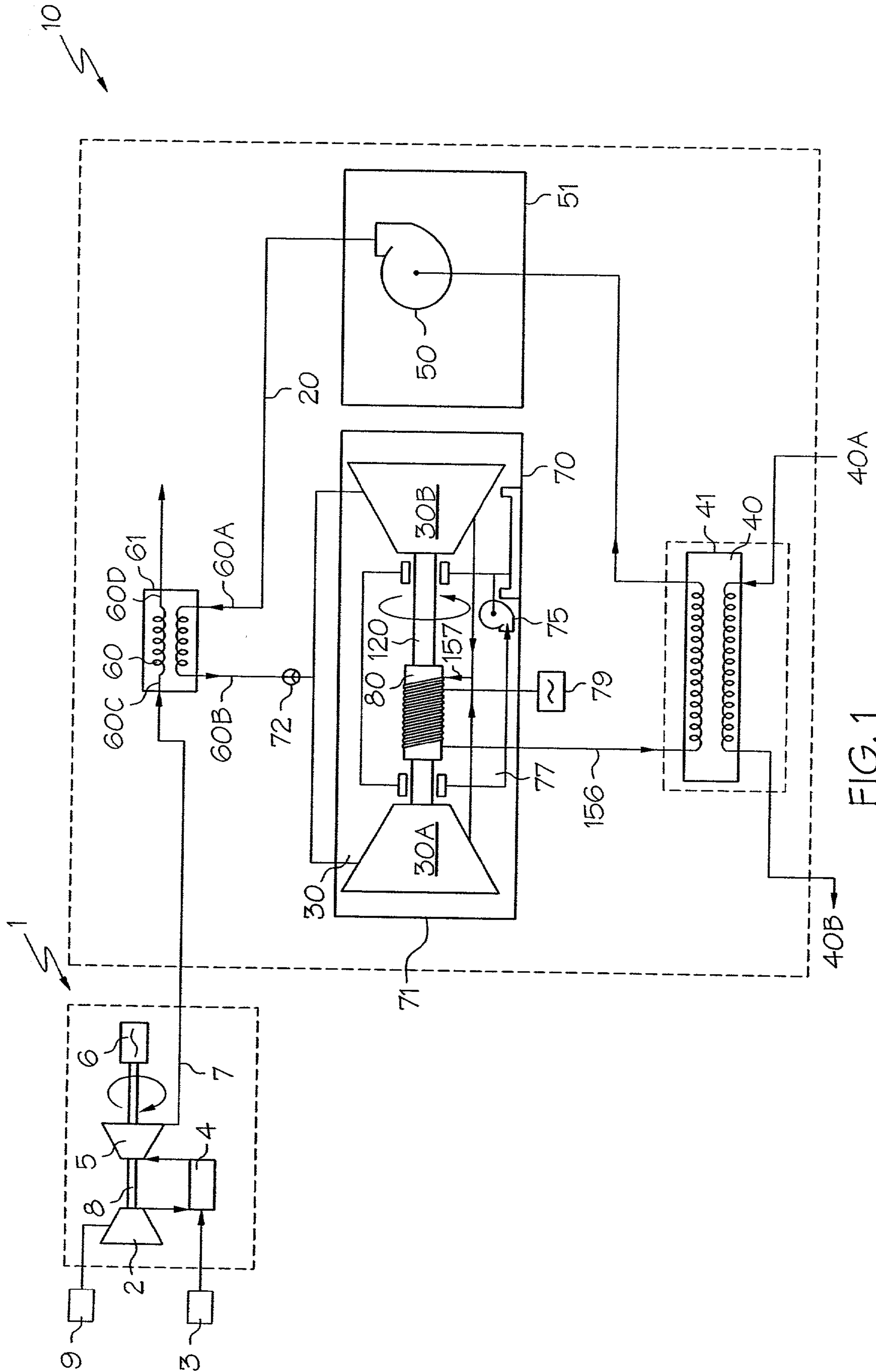

FIG. 1

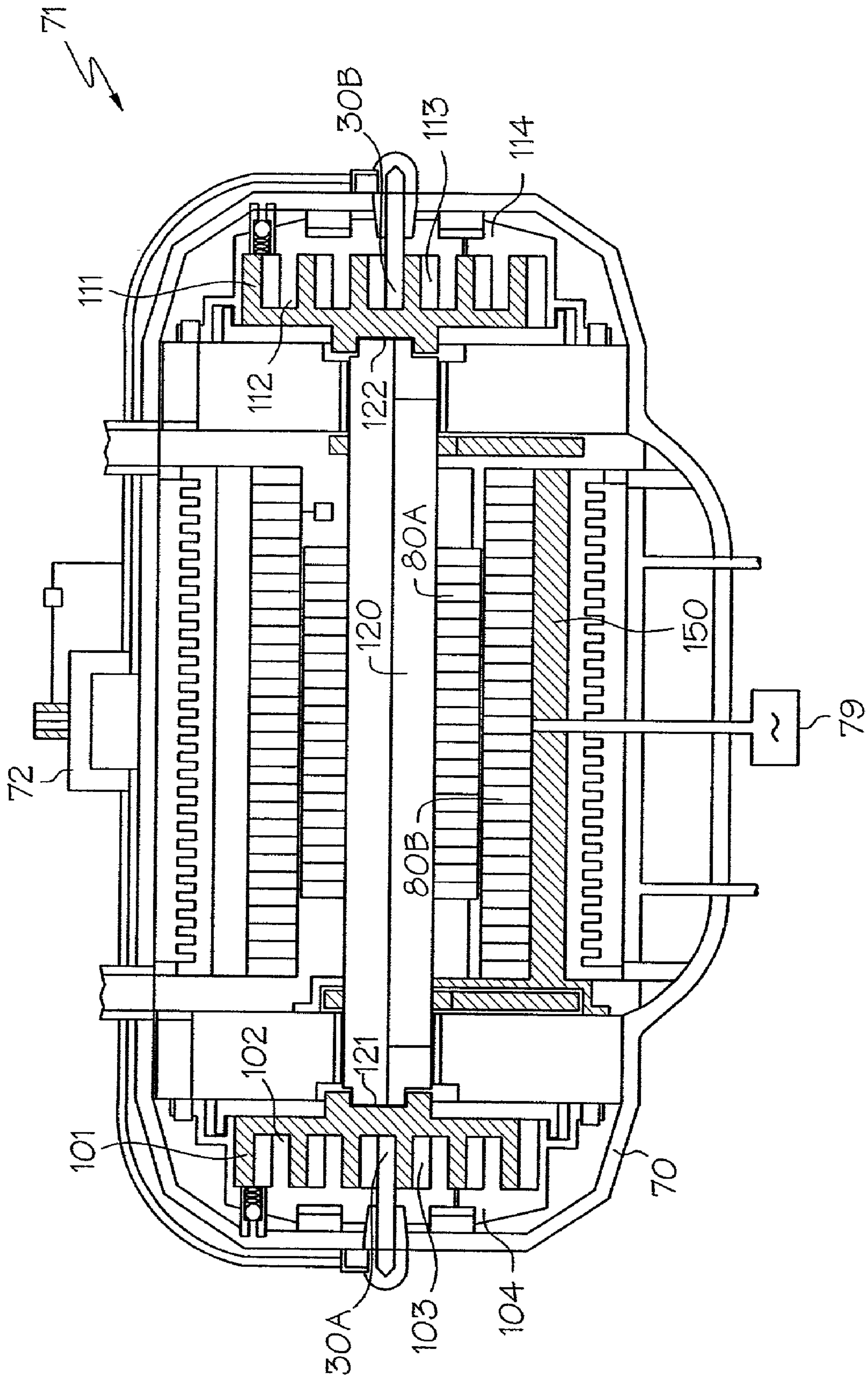

FIG. 2

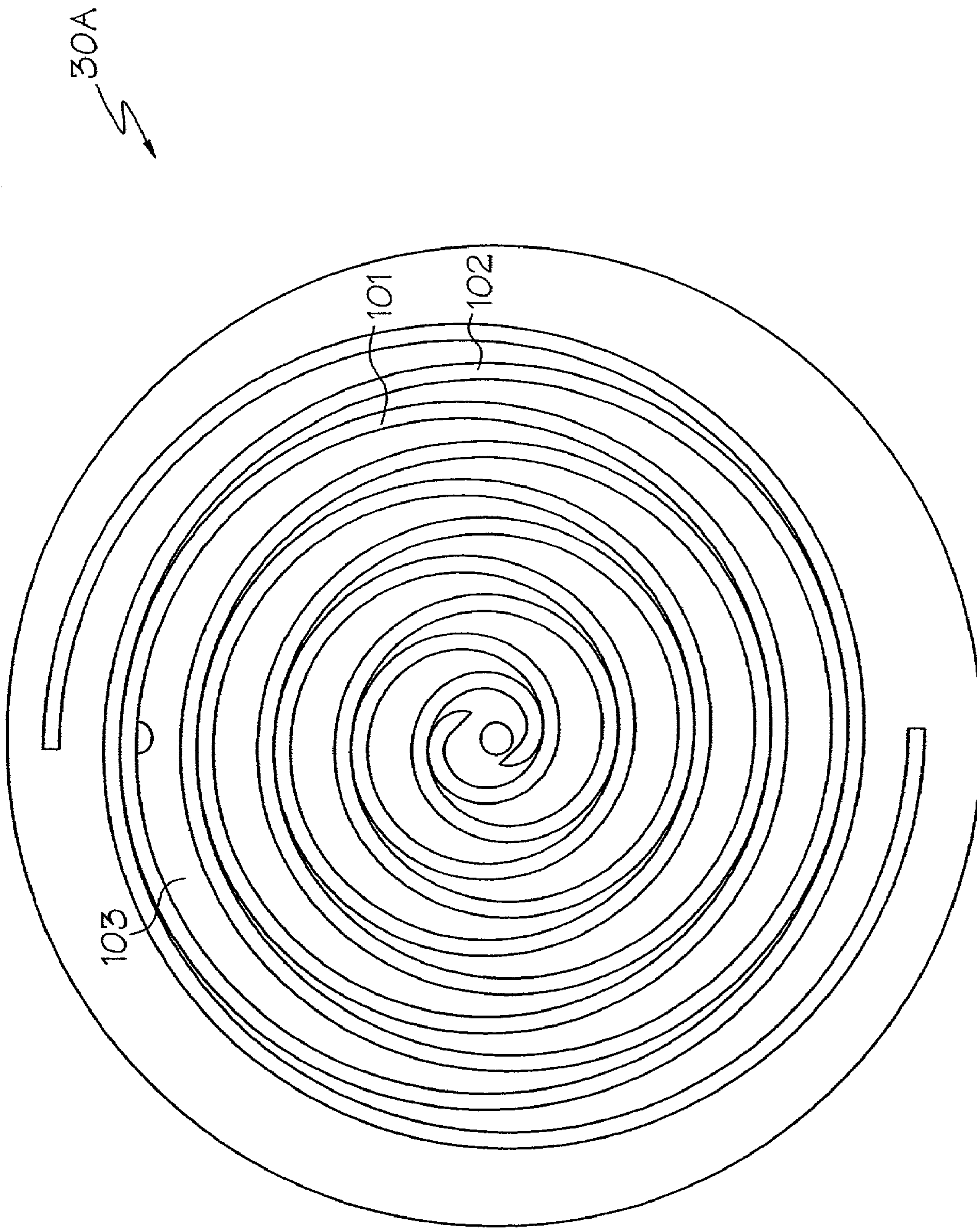

FIG. 3A

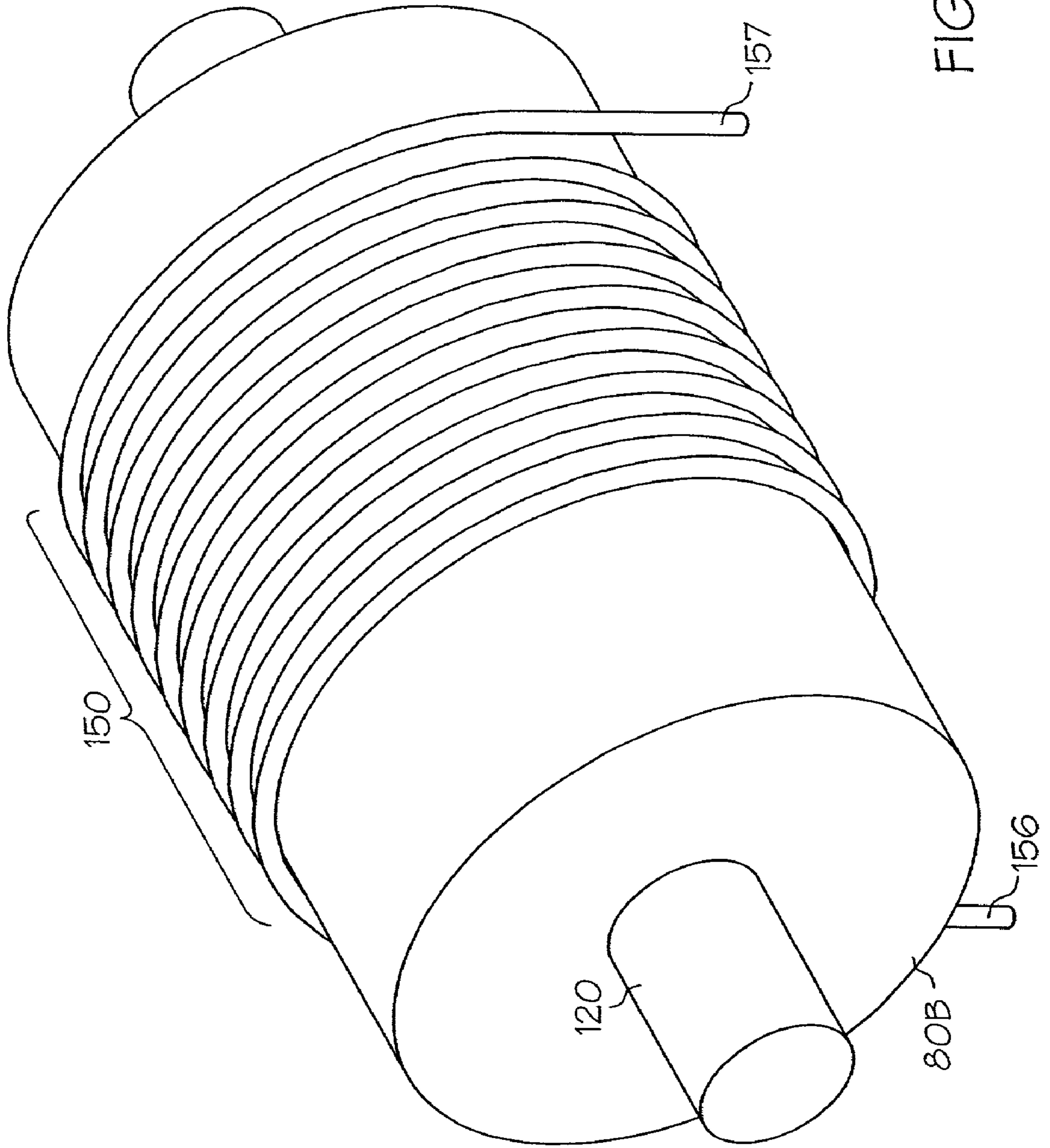

FIG. 3B

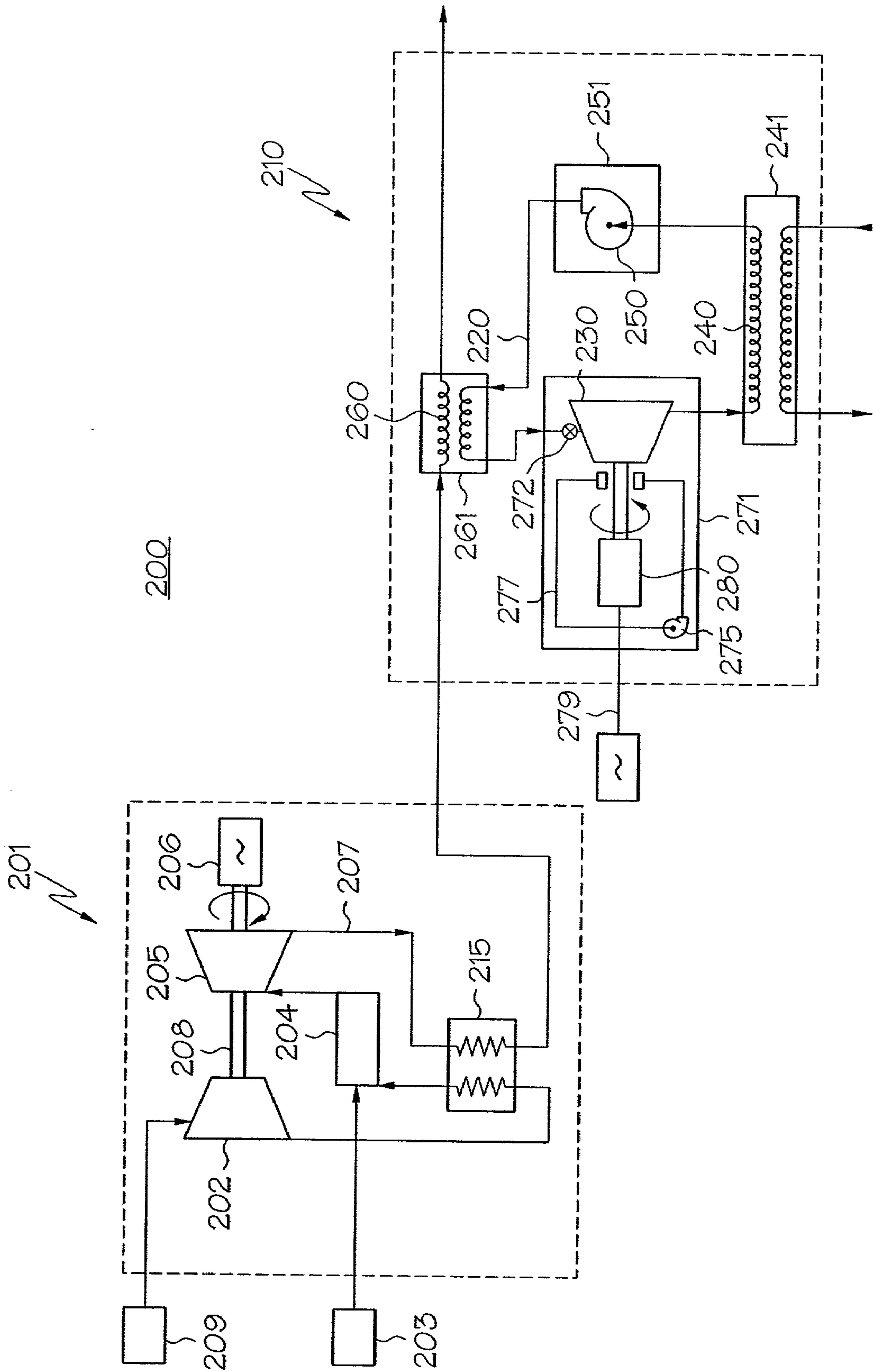

FIG. 4

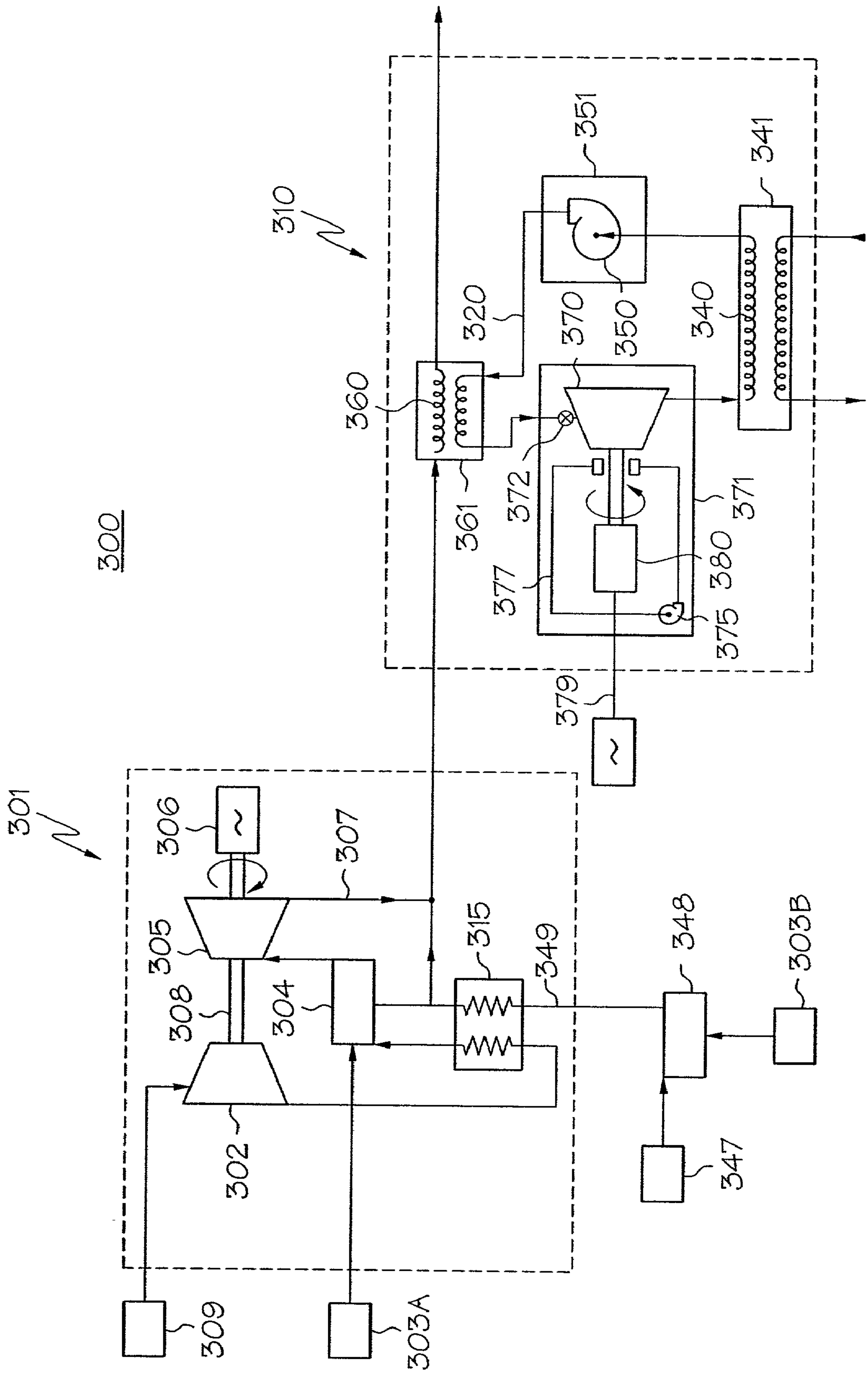

FIG. 5

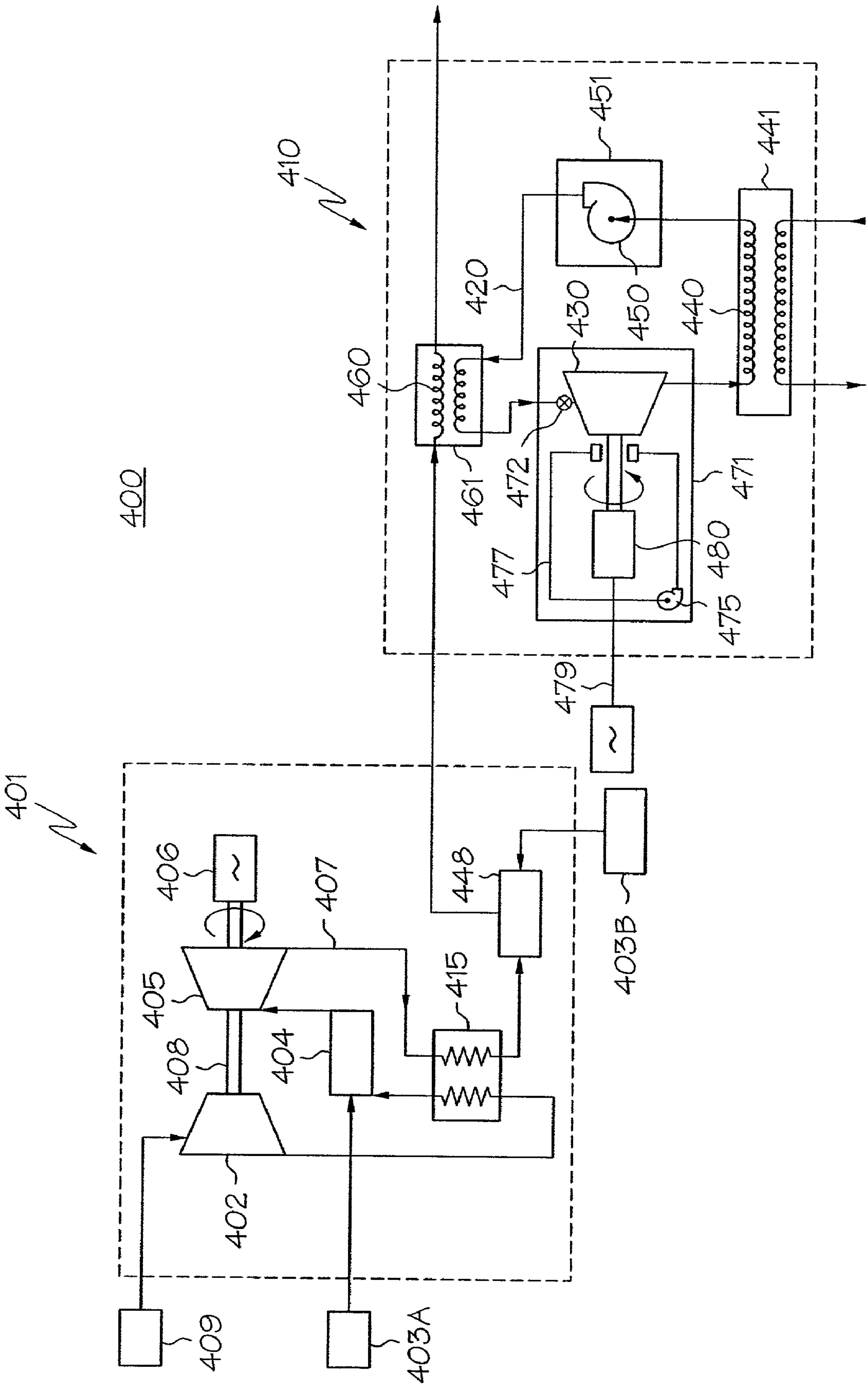

FIG. 6

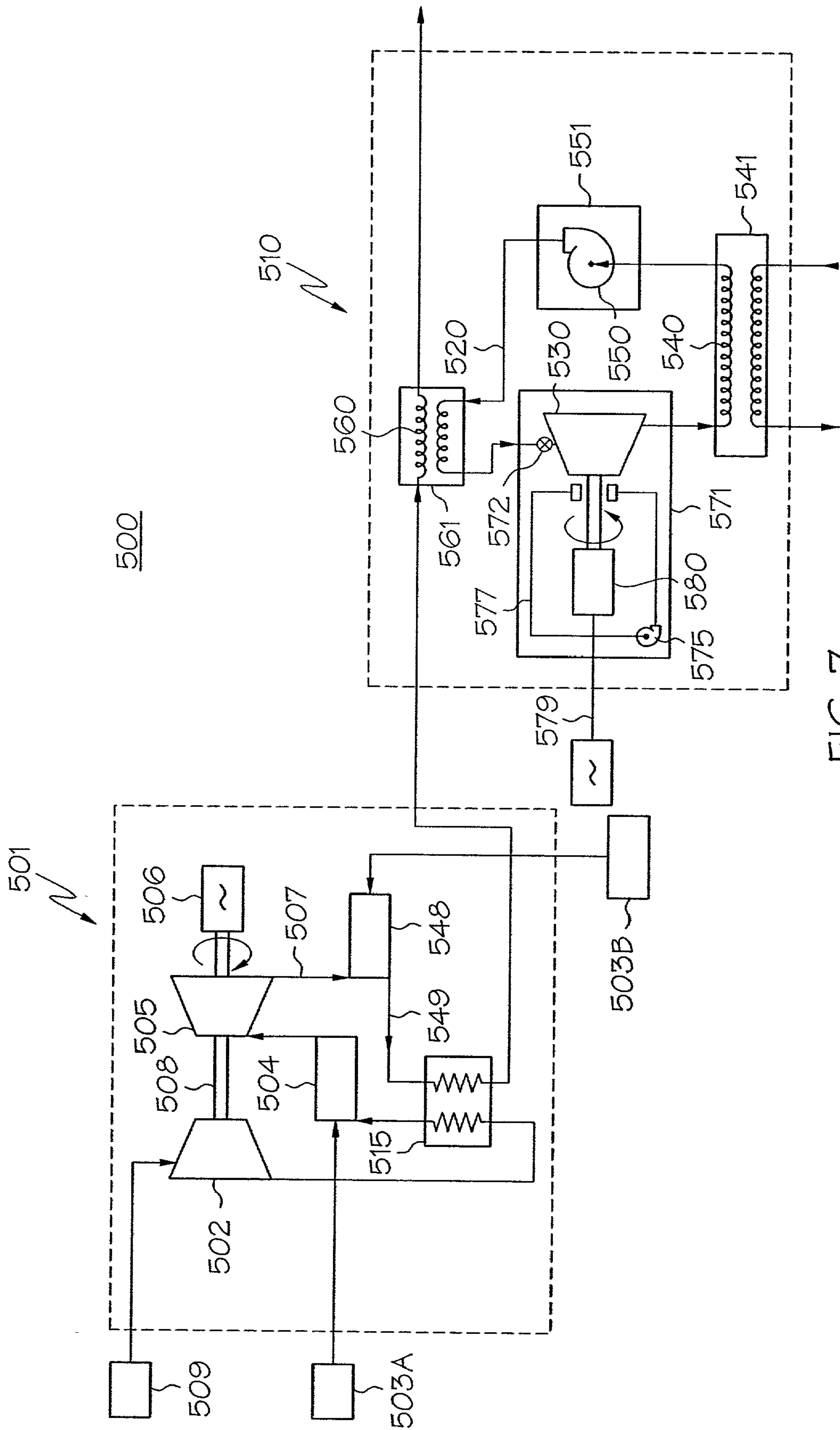

FIG. 7

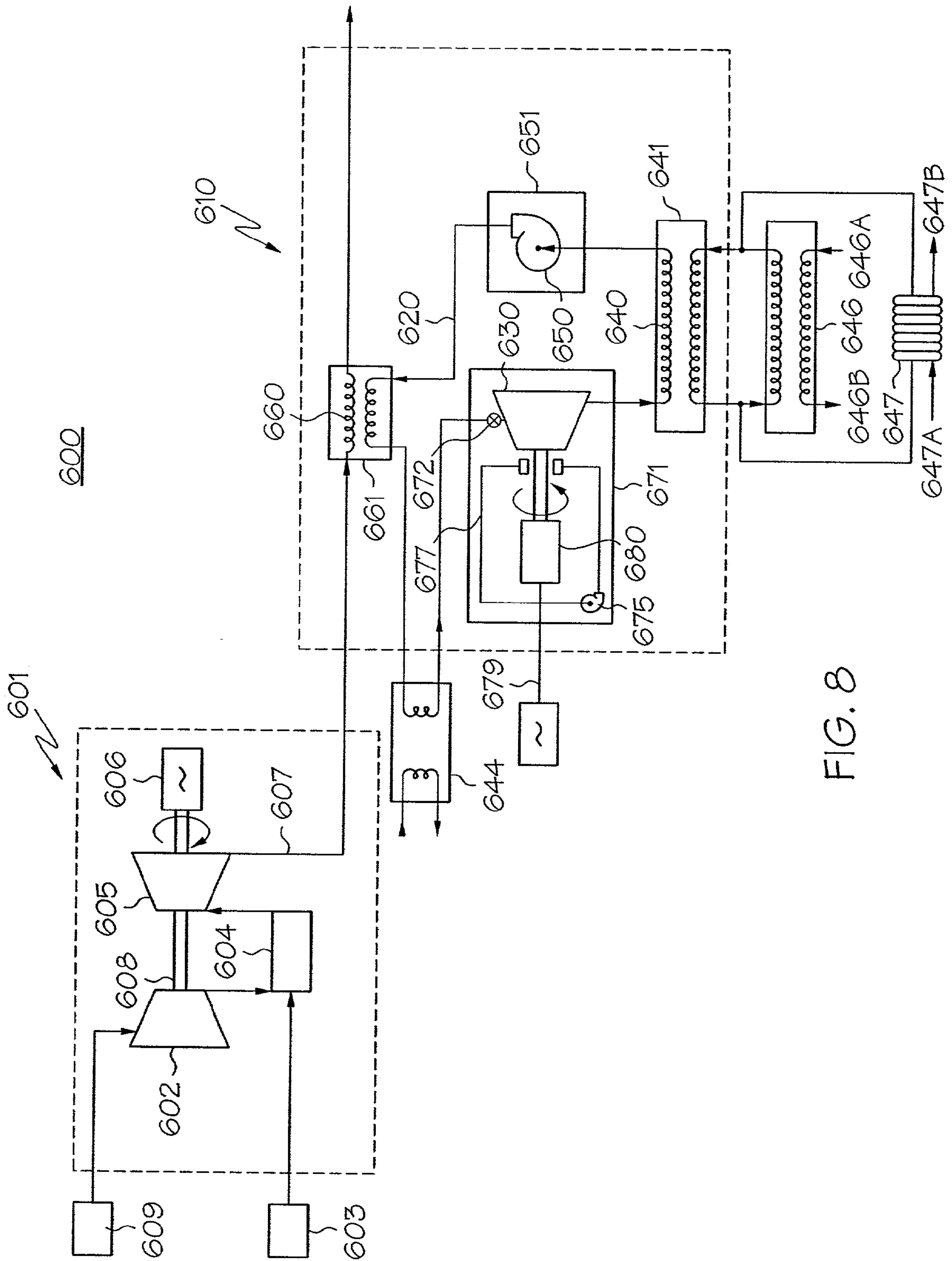

FIG. 8

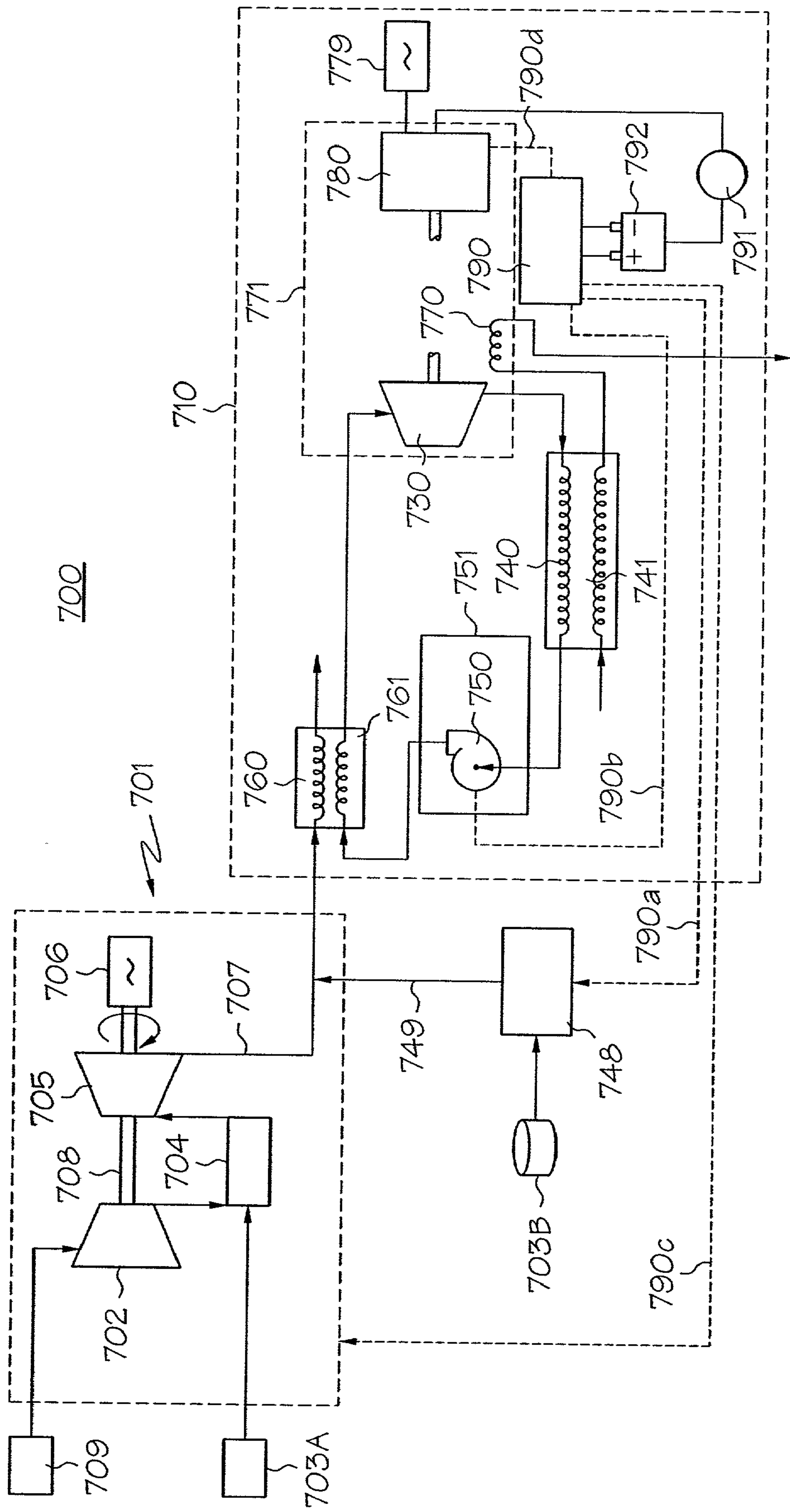

FIG. 9

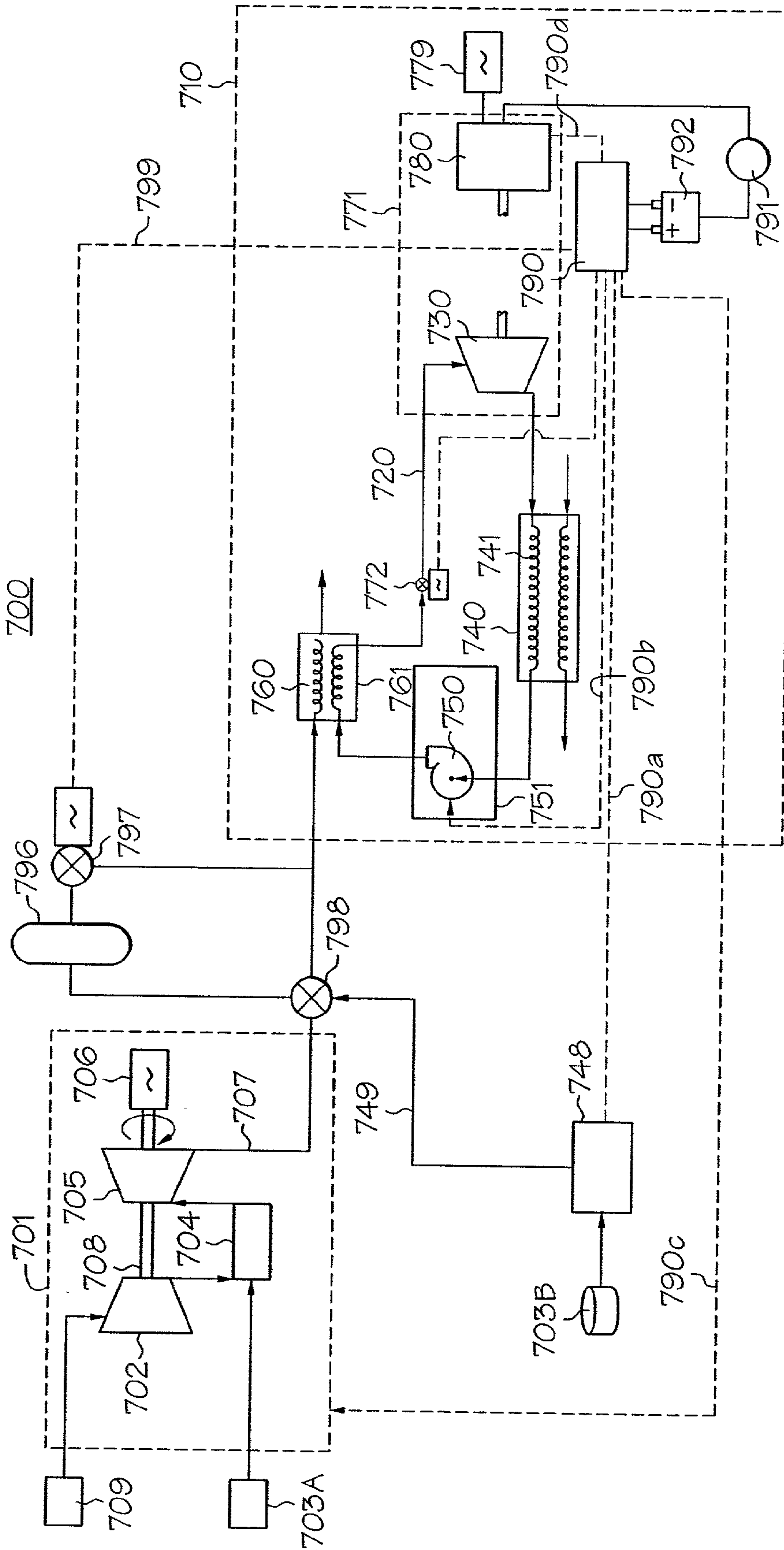

FIG. 10

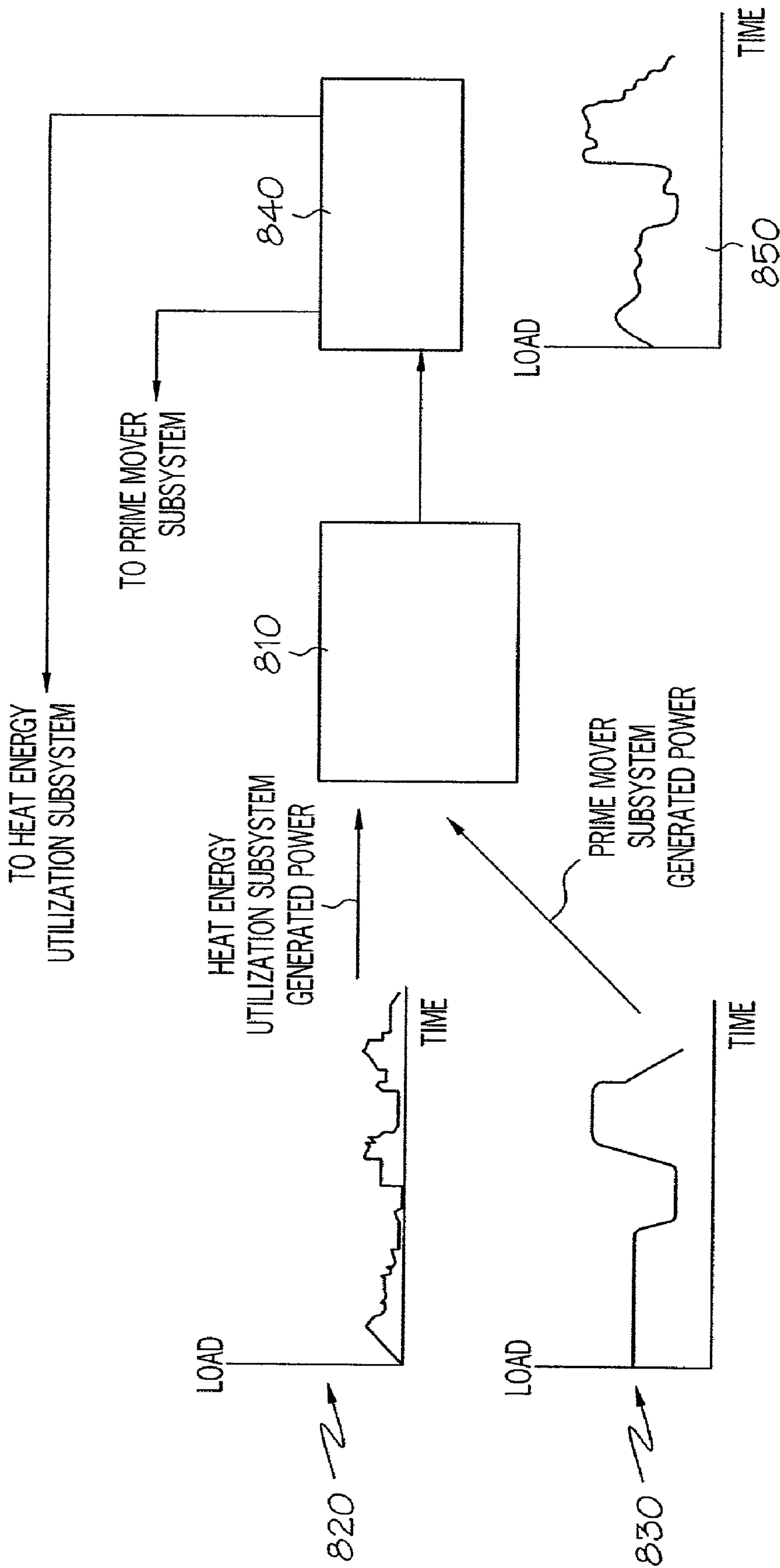

FIG. 11

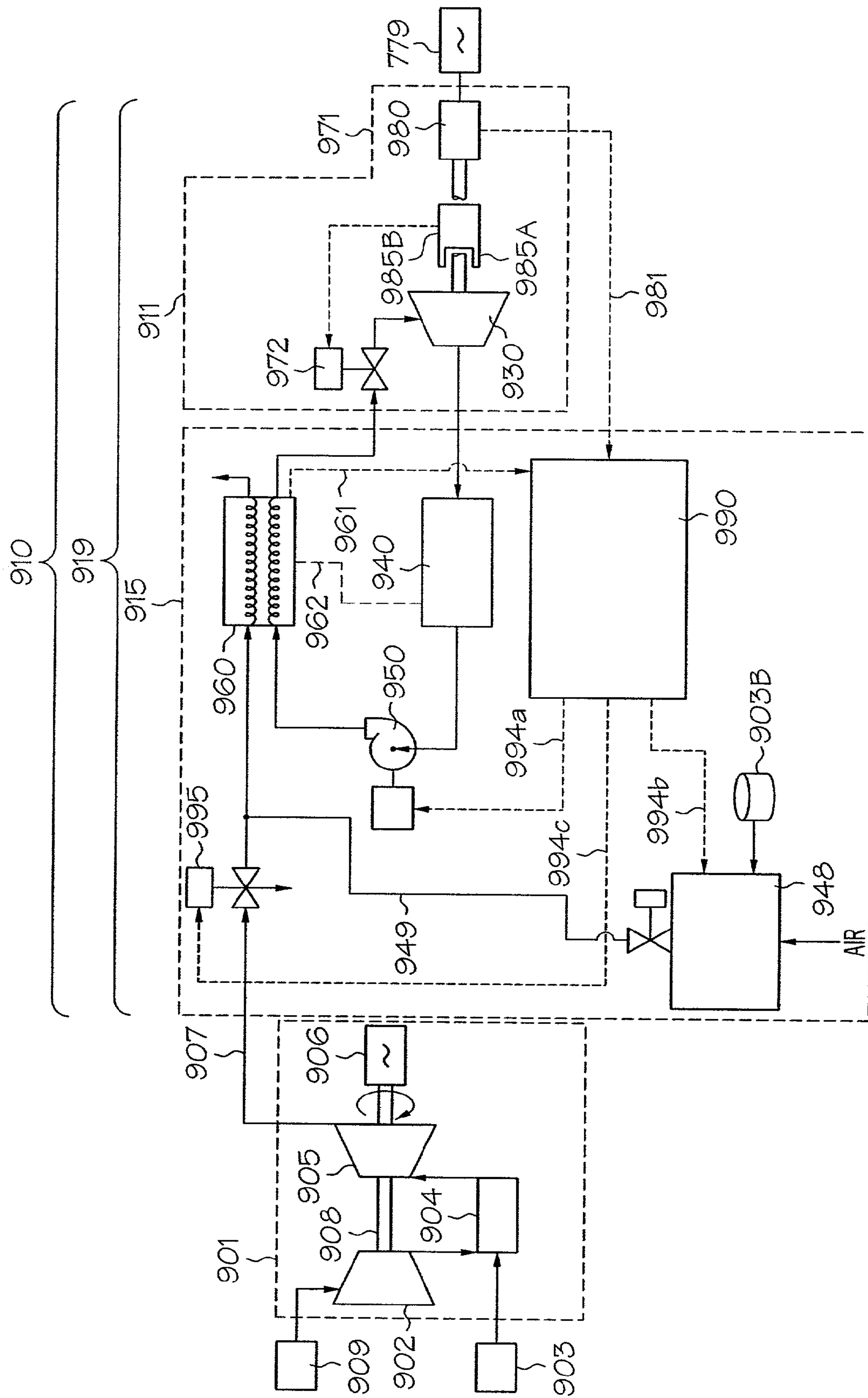

FIG. 12

HEAT ENERGY UTILIZATION SYSTEM

BACKGROUND OF THE INVENTION

[0001] The present invention relates generally to a power generation system capable of providing dual-mode (cogeneration) power demands, and more particularly to the use of a Rankine-cycle heat energy utilization subsystem in conjunction with a prime mover subsystem, wherein the otherwise unusable waste heat from the prime mover's exhaust stream is routed through the heat energy utilization subsystem for the production of supplemental mechanical or electrical power. Such combination yields a cogeneration system that can provide control over varying power demands and increase overall cycle efficiency, thereby reducing unwanted emissions.

[0002] Many commercial and industrial concerns, as well as residential users, consume widely disparate levels of electricity during the course of daily or seasonal operation. When such electricity is supplied over the grid, these concerns are often at the mercy of circumstances beyond their control, including emergency and planned service outages, as well as brownouts or blackouts stemming from heavy usage by others on the grid. In such circumstances, the electricity supplier (normally a utility company) must themselves purchase electricity from other suppliers on the grid, usually at a dramatically inflated price. This extra price is then typically passed on to the end user. In addition, even in periods where power is uninterrupted, the costs of the same quantum of electricity can be considerably higher during peak periods, which often coincides with normal business operating hours, thus rendering the option of operating during off-peak hours to get the lower electric rate unfeasible.

[0003] One way to meliorate the uncertainty of off-site electricity generation is for the using concern to generate the power on-site. The simultaneous production of electric power and useable heat from a common fuel or energy source is known as cogeneration, or combined heat and power (CHP). While large industrial entities have long been engaged in cogeneration through steam-producing boilers or reciprocating engines, the bulkiness, as well as the level of support and maintenance, of establishing such a system is prohibitive in smaller operations, such as private residences, restaurants, small commercial and light duty industrial businesses, or in geographic locations where the transmission and distribution infrastructure is inadequate or doesn't exist.

[0004] Even in circumstances where on-site generation is physically possible, the cost of installation and operation can be formidable, where new systems are extremely costly, and older systems require dedicated service and maintenance, often by skilled, highly paid specialists. In addition, the generation of energy can also carry with it hidden or hitherto unforeseen costs. Perceived impacts to the environment, in the form of gaseous, liquid and solid byproducts of the power generation cycle, such as SO_x , CO, NO_x , thermal pollution of cooling water sources, and increased ash (in the case of coal fired generators) have come under increasing levels of government and private scrutiny. Traditional power generation systems require additional effluent treatment equipment to bring air- and water-borne pollutants down to acceptable levels. The additional costs associated with installing and maintaining such equipment, as well as the cost of monitoring and compliance with strict pollution requirements, is manifest.

[0005] Microturbine technology is a relatively new field that finds its roots in conventional gas turbine engines for auxiliary power units and transportation applications. It is also part of a growing trend in electric power production, namely that of distributed generation (DG), which arose out of a need to provide alternatives to traditional grid-based power sources for small to medium-sized users. Microturbines are generally much more compact than steam-based, or even central gas turbine power units, and can provide cleaner, lower maintenance power than traditional reciprocating engines at a reasonable cost per kilowatt-hour. In addition, the relative compactness of microturbines, with or without a Rankine-cycle heat energy utilization subsystem, readily lends itself to increased system modularity, portability and upgradeability.

[0006] Configurationally, a microturbine has much in common with other gas turbine engines, including an engine housing, one or more rotating shafts, a generator, compressor, combustor, turbine, and exhaust duct. In some microturbines, the compressor, generator and turbine are coupled to a single shaft, and rotate as a unit. Normally, the shaft itself is mostly or entirely contained within and coupled to the housing, often through a bearing-mount-strut-frame arrangement well known to those skilled in the art. In a typical gas turbine system, ambient air enters through a generator section and into a compressor, which typically pressurizes the air from three- to ten-fold. From the compressor, it next goes into an optional recuperator, where the air can be preheated prior to entering the combustor to increase overall cycle efficiency. The preheating of the compressed air in the recuperator arises out of a heat exchange process with hot exhaust gas from the turbine discharge. Higher preheated air temperature leads to higher cycle efficiency, which can have dramatic impacts on life-cycle fuel usage. In addition, preheated air has the requisite temperature to facilitate a form of combustion, known as catalytic combustion (discussed below), which has been identified as a promising way to prevent the onset of NO_x formation, which is becoming a major concern in urban airsheds. After the warmed, compressed air exits the recuperator, it enters the combustor, where the air mixes with high pressure fuel, with the resulting mixture burned in a combustion chamber. The hot gas next enters the turbine section and impinges on the turbine rotor, so that as the gas expands through one or more stages of the turbine section, it causes the rotor to spin, which in turn drives the compressor. A generator may also be driven by that rotor, or by a second turbine rotor driven from the exhaust of the first rotor. Upon leaving the turbine section, the hot exhaust gas gives up some of its excess heat in the aforementioned recuperator to heat up the incoming air. Finally, the exhaust gas is ducted through an exhaust into the atmosphere.

[0007] While microturbines are particularly well-suited to providing prime mover power in a cogeneration system, it is not necessary that the prime mover be a microturbine. For example, conventional gas turbines, steam boilers (powered by burners fired by natural gas, coal, oil, or possibly even nuclear reactors), diesels, fuel cells, thermoelectric, thermophotovoltaic and even renewable sources, such as solar energy and combustible biomass all provide viable alternatives. These cogeneration approaches are part of a larger class of power plants often referred to as "combined cycle", where a higher-temperature thermodynamic cycle rejects its heat to a lower-temperature thermodynamic cycle that typi-

cally utilizes a different working fluid. The two cycles making up a combined cycle are typically known as topping and bottoming cycles, with the topping cycle often referred to as a prime mover subsystem, and the bottoming cycle as a waste heat recovery, or energy utilization, subsystem. Combined cycle operation is common in larger size units, such as systems with a power output of 10 megawatts (MW) or greater. These systems often employ a gas turbine topping cycle and a steam turbine Rankine bottoming cycle, where the high temperature exhaust gas from the prime mover subsystem is used to drive a waste heat steam turbine. However, when the prime mover subsystem is a smaller unit, such as a microturbine, the addition of a similar steam turbine system results in a degree of complexity that sacrifices many of the microturbine's modular features, as well as paving the way for significant cost growth, both in initial purchase price and the higher cost of maintenance. Moreover, the use of conventional steam based systems with which to exploit the waste heat's useful energy necessitates the use of high vacuum condensers and cooling towers. In addition, steam systems and many other heat energy utilization systems are not hermetically sealed, thus exposing the user to increased mess and maintenance issues. In either case, such configurations present unacceptable situations to small commercial and residential users.

[0008] Accordingly, there exists in the art a need for a system which can provide compact, clean, inexpensive, reliable, low maintenance, on-demand power with flexibility to tailor electrical or mechanical power output to the users' particular needs.

SUMMARY OF THE INVENTION

[0009] The present invention satisfies the aforementioned need by providing a means by which heat from a prime mover subsystem is used to drive a secondary subsystem that generates additional power.

[0010] According to an embodiment of the present invention, a heat energy utilization system includes a heat engine that is made up of at least a thermal circuit, a pump, a power module and a pair of heat exchangers. As defined herein, a "thermal circuit" is piping or ducting designed to carry fluid through a path that interconnects the various heat energy utilization system components. Similarly, the term "pump" includes any device that can be used to increase the fluid flow rate or pressure. The power module is itself made up of at least an expander and a load absorbing device. The load absorbing device can be another pump, gearing, generator or similar energy conversion apparatus. The heat energy utilization system is designed to be run as either a stand-alone power generation source, or as an optional bottoming cycle for a larger system such that it extracts heat from the heat stream of a prime mover such as an exhaust gas waste heat stream, or a dedicated heat producer. In either configuration, when the heat energy utilization system is operational, it generates useable work via vapor expansion of a working fluid through the thermal circuit. In the present context, the term "useable work" is that which is capable of producing a tangible mechanical or electrical effect, such as rotating or reciprocating motion in a shaft or related device against a resistance (in the case of mechanical work) or an electric current flow and potential (in the case of electric work). As such, the mere creation of any non-recoverable work is excluded from the instant definition of "useable work", and

that the operation of all thermodynamic cycles produces at least some heat that is non-useable. Nevertheless, the present inventors have discovered that the waste heat or exhaust gases emitted from a microturbine are capable of performing additional useable work, as they are well-suited to powering a Rankine-cycle subsystem to recover and reuse the exhaust gas energy as additional power, thus further enhancing the efficiency of the overall power generation cycle. The present inventors have also recognized that while the heat energy utilization system can be of either open or closed variety, the preferred configuration is closed, comprising a continuous loop requiring no external fluid makeup, save that associated with normal system losses occurring over long periods. The chief advantage of the closed system is that it is self-contained, and therefore more adaptable to modular uses, as well as uses where maintenance and cleanliness/neatness issues are important. In the present closed cycle heat energy utilization system, the working fluid can be any number of compounds, such as organic refrigerants, water, ammonia, propane or N-butane. The pump pressurizes the working fluid, which is then routed to a first of the heat exchangers (such as an evaporator) that boils the working fluid by absorbing heat from an external heat stream. From the evaporator, the working fluid passes to an expander in the power module. The expanding working fluid can then impart work to the expander, which can then turn a coupled shaft to produce mechanical, or, if attached to a generator, electrical, work. After passing through the expander, the working fluid is cooled and condensed in the second heat exchanger (typically a condenser) so that it can return to the pump and start the cycle all over again.

[0011] The inventors have recognized that a primary advantage of the heat energy utilization system of the present invention is that key components, including pumps, expanders, heat exchangers and electric generators can be contained within individual hermetically sealed modules in the heat energy utilization system. This is especially relevant to a power module where the expander is coupled to an electric generator. Thus, for example, a "hermetically sealed" expander would have self-contained moving parts, including bearings, orbiting shafts, rotating shafts and disks, armature coils and optionally heat exchange and lubricant-circulating devices that are contained within a module shell so as to be sealed from the external environment. Thus, save fluid inlet and outlet ports, and possibly an access port through which additional working fluid or lubricant may be added to periodically replenish that lost during normal operation, and electrical connectors to carry electricity to or from the generator, the power module operates in complete autonomy, thus avoiding maintenance issues and the mess associated with lubricants, leaky seals and noisy machinery. In addition to permitting application in places where cleanliness is paramount, such as around people, foodstuffs, sensitive electronic equipment and damage-susceptible chattels, the system exploits its inherent modularity to permit it to be moved or upgraded as requirements demand.

[0012] One way the power module is able to remain hermetically sealed is through the use of a scroll expander. While hermetic operation is not unique to scroll configurations, the present inventors recognize that, by virtue of the low number of moving parts (with attendant reduction in maintenance) in a scroll device, its configuration is an especially good fit with the limited access inherent in sealed environments. In a scroll (also known as an involute spiral

wrap) device, which can be operated as either an expander or compressor, one or more pairs of meshed axially extending involute spiral wrap members, one fixed to the housing, the other attached to and orbiting with a shaft, are axially meshed to define a plurality of crescent-shaped chambers which, by virtue of the orbital motion of one wrap member relative to the other changes the shape and size of the crescents, which in turn changes the pressure of the fluid contained therein. In an expansion mode, the fluid enters through a central port, and proceeds circuitously in a radially outward direction, causing the crescent chambers to move, which, through an anti-rotation mechanism (such as an Oldham link or a ball coupling ring assembly), consequently turns an eccentric linkage, coupled to the orbiting scroll. The linkage is attached to a rotating shaft with an offset functionally equal to the radial distance from the rotational axis of the shaft, thereby transforming the scroll orbital motion into rotating motion in the shaft. Conventional needle bearings can be placed in the eccentric aperture to reduce friction between the linkage and the orbiting scroll.

[0013] As mentioned above, the scroll expander could further incorporate two scroll pairs, each disposed on opposing ends of a common rotating shaft. Each pair is in turn made up of the aforementioned pair of meshed axially extending involute spiral wrap members for symmetric bearing loading, annular cooling channels, an optional external armature for supplemental electrical power generation, and axial compliance features to avoid thermal expansion mismatches. This dual scroll configuration is especially valuable in providing a third, hybrid operational mode, where one of the spiral wrap members can be operated in expansion mode while the other concurrently operates in compressor mode. This and additional features of the scroll device with an integral field-generating rotor are described in copending application, U.S. Ser. No. 09/681,363, INVOLUTE SPIRAL WRAP DEVICE, filed Mar. 26, 2001, by Sullivan et al., herein incorporated by reference. Regardless of being configured as a single or dual scroll device, the scroll of the present invention is a low maintenance device largely due to the rolling versus sliding contact of the scroll wall flanks, the elimination of dynamic seals, and the elimination of valves. The inventors have recognized that the use of a scroll expander in the present invention heat energy utilization system has significant advantages over traditional bottoming cycle devices. The small number of parts associated with the scroll design, coupled with its inherently simple motion ensures a low maintenance part that can be placed in an infrequently-accessed sealed container. The hermetic sealing unique to this approach facilitates an entirely integrated, modular power generation system. Additionally, the compact nature of the expander can be made even more diametrically compact through the use of dual opposed scroll wrap members, such as those described in the aforementioned copending application. Many significant advantages of the scroll machine have been proven with the successful use of scroll compressors in the refrigeration and air conditioning industry.

[0014] In the case where the desired power output is electrical, the load-absorbing device can be a generator made up of a field-generating rotor situated around the periphery of a rotating shaft. A stator coil in inductive proximity to the field rotor could be affixed to the outer portion of the scroll housing, but still within the module's larger hermetic seal shell. When the scroll device is oper-

ating in expansion mode, alternating current electricity could be passed from the generator, through the hermetic shell via electrical conductors, and to attached electrical connectors. Thus, power output can be effected without having to pass a shaft (and attendant sealing mechanisms) through the hermetic housing, thereby alleviating concerns over seal boundaries and leakage/contamination paths.

[0015] Another option to the heat energy utilization system is the inclusion of one or more process heat utilization modules that can extract heat from the thermal circuit for various process needs, while still providing supplemental power from the heat energy utilization system's power module. Preferably, the heat recovery modules include at least a low temperature unit to provide for lower temperature process requirements (such as warming air in dwelling spaces occupied by people, referred to as space heat), and a high temperature unit to provide higher temperature process requirements, such as domestic hot water or steam. This feature has the advantage of accommodating additional user needs, beyond just electricity requirements, to provide hot water, heated air or steam, among others.

[0016] Another option includes a heat energy utilization system quick-start module. The quick-start module permits the heat energy utilization system to either pre-start prior to the operation of an optionally attached prime mover, thus speeding up its response time, or to operate as the sole provider of power in dynamic (i.e.: rapidly fluctuating) or lower power modes where operating a prime mover would be impractical. All modern power generation systems, including microturbines, require initiation, or start-up, of their operating sequence. Typically, this is effected by a logic and control module that is capable of sending control signals to the various components within the system. An energy storage (or auxiliary power) unit, such as an electrical battery, of sufficient size is included to power the logic and control module and related equipment. A recharging module can be disposed between the load absorbing device and the energy storage unit such that extra power generated by the load absorbing device can be used to keep the energy storage device fully charged. The sequence of using the quick-start operation includes igniting an auxiliary burner and powering the pump to increase the pressure and temperature of the working fluid, which can then pass through the expander to generate power and thereafter render the system self-sustaining. The quick-start feature allows the less cumbersome heat energy utilization system to start with minimal stored energy, thus reducing the size of the energy storage unit. Once started, the heat energy utilization system can provide sufficient power to the prime mover to allow for a complete start, or, if necessary, as the sole provider of power in low or dynamic power situations, thus comprising a self-sufficient system rather than as a subsystem to a larger combination. An optional variant of the quick-start mechanism includes a high-pressure accumulator connected through one or more control and isolation valves between the evaporator and the expander. Upon cessation of normal power generation system operating conditions, the accumulator collects high thermal and pressure content working fluid. Under the quick-start mode, a control valve is opened, allowing the high pressure and temperature working fluid to boil off and enter the thermal circuit such that it can expend its excess energy in the expander. Optional pre-start activation of the auxiliary burner ensures that the working fluid will contain adequate thermal and pressure properties upon quick-start.

An isolation valve can be used to direct heat from the auxiliary burner directly to the accumulator during the starting sequence. The chief advantage of the start-up module without the high pressure accumulator is in its simplicity. The optional high pressure accumulator, on the other hand, while requiring a separate function in the control module to synchronize pump, valve and burner sequencing, will result in a more rapid response from the expander, leading to shorter start-up sequences.

[0017] According to another embodiment of the present invention, a heat energy utilization subsystem is adapted to be coupled to a prime mover subsystem, where the output of the heat energy utilization subsystem is electric potential. The heat energy utilization subsystem includes a thermal circuit, pump, hermetically sealed power module with a plurality of scroll pairs and a coupled generator to produce the electric output, a throttle valve to regulate working fluid flow into the power module, and first and second heat exchangers. The prime mover subsystem can be any power source that includes some form of thermal energy in a heat stream. In this regard, prime movers that provide an exhaust gas from a combustion process (including gas turbines and their subset of microturbines), steam (from natural gas, coal, oil or nuclear powered devices), chemical reaction (including fuel cells) as well as solar, thermophotovoltaic and thermoelectric sources are all considered valid examples that can be coupled to the heat energy utilization subsystem.

[0018] According to another embodiment of the present invention, a power generation system for providing a primary and secondary source of output power is disclosed. The primary source of output power comes from a prime mover subsystem, and the secondary source of power comes from a heat energy utilization subsystem similar to that of the first embodiment. As with the first embodiment, the subsystem may include one or more scroll pairs, as well as features capable of providing heat energy utilization subsystem quick-start, such as a control and logic module, an energy storage device, an accumulator, or an auxiliary burner in thermal communication with the heat stream. An optional throttle valve may be included to regulate the flow of working fluid to the power module.

[0019] In addition to these and the other options associated with the earlier embodiments, two additional features that could be included in the present embodiment are a capacity control module that uses proportional integral differential (PID) logic, and a load splitting module that includes a fuzzy logic controller. The first, the capacity control module, permits the heat energy utilization subsystem to respond to changes in subsystem power levels based on the analysis of control signals coming to and going from the control module. Accordingly, the capacity control module, which includes a rapid response portion and a slow response portion, is used to determine power requirements of the heat energy utilization subsystem in response to loads set on it from elsewhere (such as from the below-described load-splitting module). The PID-based controller combines the instantaneous response of proportional control with the offset correction features of integral control and the rapid response to error signals of derivative control. In applications where both the primary and secondary power output is electrical, the inventors of the present device are not aware of any prior art that allows for splitting of the electrical load between the uniform and dynamic components to be applied

to a combined multiengine thermodynamic system. Components making up the capacity control module include a speed sensor coupled to the expander, a feed-back controller operatively responsive to a signal from the speed sensor so as to actuate the valve that isolates the accumulator, a bypass valve disposed within the heat stream to control heat stream flow into the first heat exchanger module, a plurality of sensors disposed in the thermal circuit to measure the temperature and pressure of the working fluid, and a proportional integral differential logic controller to control the bypass valve, pump and auxiliary burner based on first heat exchanger sensor input signals. Additionally, the speed sensor and feed-back controller can also be incorporated within the power module hermetic shell.

[0020] The second, the load splitting module, can be used to isolate the prime mover subsystem from rapid-response dynamic loads by using a fuzzy logic controller to set loads for each of the two power generating subsystems. The load-splitting module analyzes electrical use requirements in order to set the load on each of the two power generating subsystems. The optional fuzzy logic controller is used to determine the substantially uniform load (also known as a "quasi-steady state" load, typically associated with the prime mover subsystem) component, and the dynamic load component (typically associated with the heat energy utilization subsystem). The practical applications of fuzzy logic have been on the rise in recent years, providing rule-based ways of determining continuous, intermediate truth values from vague or incomplete data sets such that a result, processable by digital computers, can be obtained. As such, fuzzy logic-based inference engines and controllers are well-suited to process-driven events, where quick, accurate monitoring of; and active feedback to, a dynamic environment can provide improvements in system response, efficiency and overall operability. Thus, with the fuzzy logic-based load splitting module, a composite electric generation profile, comprising component contributions from both the prime mover and heat energy utilization subsystems, can be produced based on an interactive controller such that the efficiency of the overall generation of electricity is maximized.

[0021] Optionally, the prime mover subsystem can be a microturbine, either without or with a recuperator. In the first instance, since the turbine exhaust gas does not have to give up its thermal content in a recuperator to preheat the compressed air going into the combustor, full exploitation of the exhaust gas can occur at the heat energy utilization subsystem's evaporator. Thus, the non-recuperated variant has the advantage of having the simplest interconnection and operation, as well as the smallest, least obtrusive footprint, thus maximizing its affordability. Specific power, a common metric expressed as the ratio of power output to either weight or displaced volume of the system, is also maximized in the non-recuperated subsystem. In the second instance, the microturbine-based prime mover subsystem employs a recuperator, which is essentially a dual-loop heat exchanger connected between the compressor discharge and the combustor inlet for the first loop, and between the turbine exhaust and ambient for the second loop. The turbine exhaust gas, after giving up its heat in the recuperator to raise the temperature of the air coming out of the compressor, will have a lower energy content than that for the non-recuperated device of the previous embodiment, and therefore will have less energy to give up to the Rankine-

cycle heat energy utilization subsystem. To make up this difference, the recuperated subsystem variant can also include a separate prime mover auxiliary burner which could be included with, but external to, the modules of the heat energy utilization subsystem for situations requiring high efficiency. The prime mover auxiliary burner could be placed at various locations in or around the prime mover to optimize its effectiveness, such as either upstream or downstream of the recuperator, or in a mixing relationship with the fluid directly leaving the turbine exhaust. The benefits of incorporating the recuperated subsystem features include the aforementioned easy start-up due to the presence of low pressure pre-start components, as well as not requiring a high efficiency recuperator to achieve suitable overall system performance.

[0022] The higher prime mover combustor inlet temperatures made possible through the use of a recuperator would also permit a catalytic combustor to be utilized in place of the conventional combustor. The use of a catalytic combustor permits combustion byproducts that would otherwise be discharged as gaseous or particulate pollutants to be burned, or chemically altered to less objectionable species, thus providing the dual benefit of generating additional power while simultaneously reducing airborne pollutants. With a catalytic combustor, when exhaust gases and particulate come in contact with a noble metal coated ceramic core, chemical changes occur in the byproducts that permit them to ignite at relatively low temperatures, thus promoting more complete combustion, even in lower temperature operating regimes. To be effective, the air entering the catalytic combustor must itself be substantially preheated to promote the chemical reaction. The inventors of the present invention have recognized that a recuperator and a catalytic combustor can be placed in series with a supplemental, low pressure burner to reheat a turbine exhaust stream prior to introduction of that stream into the heat energy utilization subsystem's evaporator. In addition, multistaged turbines and compressors could be employed to add more flexibility to the design, effecting decisions on how much supplemental burner heating is necessary. From such a configuration, bleed or discharge ducts could route exhaust streams of appropriate pressure and temperature to any of several desired locations. The advantage of this feature is that the coupling of the catalytic combustor and recuperator, as part of this flexible embodiment, is particularly well-suited to extremely low emissions operation, and is in keeping with the overall system's flexibility features.

[0023] In accordance with still another embodiment of the present invention, the prime mover and heat energy utilization subsystems are integrated to provide both a primary and secondary source of power. In the present context, the term "integration" means more than the mere interconnection of disparate subcomponents, as true integration is an engineering solution designed around the proper interrelationship of these subcomponents, especially on how variations in the performance of one effects not just another, but the system as a whole. To that end, the system of the present invention includes, among other factors, considerations of size, load dynamics isolation and load splitting, heat energy utilization subsystem capacity control, durability, flow rates, quick-start sequencing, temperatures, pressures, acquisition and life-cycle costs, pollution minimization and aesthetics. The approach of this embodiment is especially beneficial when the prime mover is a microturbine, which can furthermore be

either non-recuperated or recuperated. This allows system designers the flexibility of accommodating varying combustor and emissions requirements, such as the use of a catalytic combustor, into the overall power generating system. In addition to a microturbine prime mover, the system of the present embodiment includes a heat energy utilization subsystem, which in turn includes a closed loop thermal circuit, pump, first heat exchanger, hermetically sealed power module with scroll expander and load absorbing device, and a second heat exchanger. The invention described herein represents a practical and cost-effective approach to achieving a microturbine combined cycle (MTCC) at a much smaller scale than gas turbine combined cycle (GTCC) power plants currently in use.

[0024] The system of the present embodiment may be outfitted with the same options as that of the heat energy utilization system of the first embodiment, as well as the optional load-splitting module and the capacity control module of the previous embodiment. In the present embodiment, these additions are now integral features the combination of which can provide a total power generation package. The advantage of the integrated system is the resulting turn-key approach to providing solutions to a user's power requirements, including automated system operation modes. For example, the load-splitting module will continually monitor actual electrical load dynamic characteristics and adjust the load split between the prime mover and heat energy utilization subsystems through the use of optional sophisticated fuzzy logic that can mimic a variety of operational parameters without the need for user intervention. Similarly, the capacity control module will monitor various parameters (such as evaporator pressure and vapor superheat temperature) with a distributed network of pressure and temperature transducers. The capacity control module's smart controller automatically analyzes evaporator pressure and temperature dynamics to provide rapid response and control to the pump, valves, and auxiliary burner firing rate.

[0025] The use of the integrated approach to incorporating the heat energy utilization subsystem herein described is well-suited to situations involving low thermal energy heat streams from the prime mover, where, by adding a low pressure auxiliary burner to energize the prime mover heat stream, sufficient heat exchange can take place within the heat energy utilization subsystem's evaporator. This approach is especially useful in gas turbine prime movers, where recuperators can be used to heat prime mover incoming air. Similarly, in non-recuperated prime mover subsystems, where preheated air for the prime mover subsystem's main combustor is not required, the heat energy utilization subsystem can be run directly off the turbine exhaust of the prime mover, thus removing the need for a burner to reheat the exhaust gas. In such a system, higher initial compression of the air entering the prime mover could provide sufficient thermal content to abrogate the recuperator. The combination of portable, modular features inherent in both subsystems is further exploited to ensure that a complete power generation package is available to the user, and can be adapted to myriad parametric requirements. By tailoring the needs of the heat energy utilization subsystem with the capabilities of the heat stream provided by a prime mover, a system optimized for size, power and emissions output and cost can be effected.

[0026] In accordance with another embodiment of the present invention, a method for producing power by using a power generation system made up of a prime mover subsystem and a heat energy utilization subsystem comprises the steps of operating the prime mover to turn a first electric generator, arranging the components of the heat energy utilization subsystem such that at least an evaporator is in a heat exchange relationship with the heat stream generated by the prime mover, an exchange of heat between the waste heat stream and the evaporator such that heat is transferred to a working fluid flowing through a thermal circuit that maintains fluid communication between the components of the heat energy utilization subsystem, regulating the flow of the working fluid with a throttle valve, expanding the working fluid in an expander that is coupled to a second electric generator, condensing the expanded working fluid, and then pressurizing the working fluid.

[0027] Optionally, the method could also include additional attributes and steps. For example, a throttle valve can be included to help regulate the flow of working fluid to the expander. In addition, either or both of the load absorbing devices can be a generator to generate electricity. Both the expander and second load absorption device can be hermetically sealed, while the expander is preferably a scroll device (which itself can comprise single or dual scroll pairs). A lubricant pump and a lubricant droplet separator may be used in situations requiring separation of the working fluid from the lubricating fluid, and both the pump and separator can be disposed within the hermetically sealed power module. Another optional step could include operating a desuperheating heat exchanger such that the high temperature working fluid exiting the expander can pass through the heat exchanger; the heat exchanged therein could be used for a DHW or SH loop. As previously discussed, a microturbine can be used as the prime mover subsystem. Furthermore, at least one process heat utilization module can be placed in thermal communication with the working fluid such that heat can be extracted from the working fluid and directed to the process heat utilization module. Similarly, the process heat utilization module can be placed in thermal communication with the thermal circuit to provide process heat. Another step includes using an accumulator to receive and store elevated temperature and pressure working fluid such that the accumulator can smooth out system operation during certain conditions. For example, the accumulator can be used to provide alternate steps to initiate a start-up sequence in the heat energy utilization subsystem, as can an auxiliary burner. A load splitting module can be incorporated to coordinate steady-state and dynamic load requirements in the system, while providing a capacity control module will assist in promoting better response within the heat energy utilization subsystem. The load splitting module may further be based on a fuzzy logic controller that can sense various instantaneous and historical data to provide output instructions to the prime mover and heat energy utilization subsystems.

[0028] In accordance with yet another embodiment of the present invention, a method of operating a heat energy utilization system is disclosed. The method includes the steps of arranging at least a pump, first heat exchanger, expander and second heat exchanger to be in fluid communication with one another via circulated working fluid routed through a thermal circuit. In addition, an auxiliary burner, fuel supply and auxiliary burner exhaust line are arranged

such that the auxiliary burner exhaust line is placed in thermal communication with the thermal circuit. Next, a start-up sequence is initiated in the heat energy utilization system by providing electric current to the control module so that it in turn can send start-up signals to one or more of the heat energy utilization subsystem components such that the heat produced in the auxiliary burner and routed through the auxiliary burner exhaust line exchanges its heat with the first thermal circuit such that a working fluid flowing through the thermal circuit enables the operation of the heat energy utilization system to be self-sustaining. The control of the power level in the heat energy utilization system is effected in the present method by regulating the flow of the working fluid to the expander with a throttle valve disposed within the first thermal circuit. After passing through the throttle valve, the working fluid goes through an expander such that the energy released by the expansion process turns the coupled generator, which in turn produces electricity. After passing through the expander, the working fluid is routed to a condenser for cooling, and a pump for circulating throughout the first thermal circuit. By this entire method, the heat energy utilization system is capable of sustained, stand-alone operation.

[0029] Optional steps in the method include hermetically sealing the expander and generator in a power module, as well as utilizing a scroll device in the power module's expander, as well as placing a lubrication system within the hermetic shell, and removing excess heat from the expander through a desuperheating heat exchanger, both of the last two in a fashion similar to that used in the previous method. Additional steps that may be embodied in the current method further include utilizing a microturbine as the prime mover system, and utilizing either or both high and low temperature heat recovery modules in thermal communication with the condenser of the heat energy utilization system, such that the heat recovery module can extract heat, thereby producing process heat in addition to, or in place of a secondary electric generation output. Also, in addition to operating the heat energy utilization system with quick-start features, the method can incorporate load-splitting and capacity control, both as described in conjunction with the previous embodiment.

[0030] Other objects and advantages of the invention will be apparent from the following description, the accompanying drawings, and the appended claims.

BRIEF DESCRIPTION OF THE DRAWINGS

[0031] FIG. 1 is a schematic illustration of the basic components of one embodiment of the present invention including a microturbine prime mover subsystem integrated with a heat energy utilization subsystem;

[0032] FIG. 2 is a simplified illustration of a scroll expander-based power module according to an embodiment of the present invention, illustrating the use of dual spiral wrap members to drive a rotating electrical generator rotor by means of an orbiting shaft;

[0033] FIG. 3A is an end view of the one of the dual spiral wrap members of the scroll expander and annular heat exchanger;

[0034] FIG. 3B is a perspective view of a heat exchanger disposed in relation to an electric generator stator coil;

[0035] FIG. 4 is a schematic illustration of another embodiment of the present invention including a catalytic combustor and recuperator;

[0036] FIG. 5 is a schematic illustration of another embodiment of the present invention including a secondary atmospheric-pressure combustor augmented device;

[0037] FIG. 6 is a schematic illustration of a variation of the embodiment shown in FIG. 5;

[0038] FIG. 7 is a schematic illustration of a variation of the embodiment shown in FIG. 5;

[0039] FIG. 8 is a schematic illustration of a variation of the embodiment of FIG. 1, including high temperature and low temperature heat recovery modules;

[0040] FIG. 9 is a schematic illustration of a variation of the embodiment of FIG. 1, including details of a first quick-starter element;

[0041] FIG. 10 is a schematic illustration of a variation of the embodiment of FIG. 1, including details of a second quick-starter element;

[0042] FIG. 11 is a general flow diagram showing the use of a load-splitting module between the prime mover and heat energy utilization subsystems; and

[0043] FIG. 12 is a schematic illustration of a capacity control feature of the heat energy utilization subsystem.

DESCRIPTION OF THE PREFERRED EMBODIMENTS

[0044] Referring now to FIG. 1, a prime mover subsystem 1 and heat energy utilization subsystem 10 are shown. While the preferred source for the prime mover is a microturbine, it will be appreciated by those skilled in the art that other devices, such as conventional small gas turbines and reciprocating internal combustion engines, can be used as a means for generating a primary source of power. Other previously discussed prime movers, although not shown, are also within the ambit of the present invention. The prime mover subsystem 1 comprises generally a compressor 2, external fuel source 3, combustor 4, turbine 5, alternator 6 and turbine exhaust 7. As will also be appreciated by those skilled in the art, all the embodiments shown notionally in the drawings are equally applicable to single-stage and multi-stage compressor and turbine devices. Compressor 2, turbine 5 and alternator 6 are shown in the figure on a common shaft 8. Ambient air 9 enters the compressor 2, and by the rotation imparted on the rotor (not shown) from the turning shaft 9, becomes pressurized. Upon discharge from the compressor 2, the air 9 enters combustor 4, where it is mixed with fuel from the fuel source 3, and then burned. The now high-temperature, high-pressure combustion gas enters the turbine 5, where the gas imparts its energy on the turbine rotor (not shown), which turns the rotor and connected shaft 8, which causes the compressor 2 to turn, thereby pressurizing the incoming air 9 in a continuous cycle. After passing through and giving up a significant part of its energy to the turbine 5, the heat stream 7, in the form of exhaust gas, is discharged through the exhaust (not shown). The turning of shaft 8 causes the shaft-mounted alternator 6 to produce electricity.

[0045] To take full advantage of the energy produced in the prime mover subsystem 1, the heat energy utilization

subsystem 10 is provided. The basic components of the heat energy utilization subsystem 10 include a working fluid routed through a thermal circuit 20, an expander 30 (shown notionally as a dual expander with split expansion members 30A and 30B), condenser 40, pump 50 and evaporator 60. The first thermal circuit 20 is in fluid communication with expander 30, condenser 40, pump 50 and evaporator 60 to define a closed loop. Many of these individual components can be housed within separate shells or containers for the purpose of isolating the components from ambient conditions. For example, power module 71, the particulars of which are discussed in extensive detail in the aforementioned copending application, includes a hermetic housing (or shell) 70 encasing expander 30 and generator 80. Other load absorbing devices besides generator 80 are possible. For example, a rotating shaft could be used to provide mechanical power to a motor or pump. Throttle valve 72, which controls the amount of working fluid allowed to flow through first thermal circuit 20, may be either encased within, or positioned on, hermetic housing 70. In addition to power module 71, condenser module 41, pump/motor module 51 and evaporator module 61 can be hermetically-sealed and individually housed to maximize system modularity. Lubrication of the rotating components within the various hermetically sealed modules can be accomplished through the addition of an autonomous closed-cycle loop. An example, shown representatively in power module 71 (but equally applicable to any of the hermetically sealed modules), includes a lubricant pump 75 providing lubricant (not shown) through lubricant circuit 77. When the load absorbing device is a generator 80, the output from the power module 71 is carried through electrically conductive lines 79. The electric output through lines 79 is in addition to that produced in alternator 6, thus resulting in a dual source of electrical power from the two subsystems 1 and 10.

[0046] Fluid in thermal circuit 20 absorbs heat from the heat stream 7 of the prime mover in the first heat exchanger, which is preferably an evaporator 60. Heat exchanger first inlet 60A and first outlet 60B permit thermal interaction between thermal circuit 20 and heat stream 7, which passes through heat exchanger second inlet 60C and second outlet 60D. In either the dual electric or CHP mode, condensed working fluid, which may be an organic-based refrigerant, such as R22, R123, propane, N-butane, or the like is transported by pump 50 through thermal circuit 20 to complete the preferably closed-cycle working fluid loop. The use of such working fluids is desirable within the context of the instant application because through their use, the size of the thermal circuits carrying them is reduced, which is important in space-limited applications.

[0047] Preferably, power module 71 includes expander 30, which is an involute spiral wrap, or scroll device, and a load absorber, preferably in the form of electric generator 80. A detailed side view of power module 71 is shown in FIG. 2 and a simplified end view in FIG. 3A. While the involute spiral wrap device shown in FIG. 2 as a dual scroll device, having two spiral wrap member pairs 30A and 30B disposed at opposing ends of common shaft 120, it will be appreciated by those skilled in the art that a single spiral wrap member pair could also be employed. As previously mentioned, throttle valve 72 may be located within the power module, which may be hermetically sealed by enclosure in housing 70; by so doing the need for additional seals, such as actuator shaft seals, is eliminated. Throttle valve 72 regulates the

amount of fluid flowing through the first thermal circuit **20**, thereby acting as the primary control mechanism for varying the speed of expanders **30A**, **30B** in response to changes in requirements of the load absorbing device. The main features of the expanders **30A**, **30B** as a scroll device are the orbiting scrolls **101** and **111**, and stationary scrolls **102** and **112**. The high pressure working fluid traversing first thermal circuit **20** gives up its energy via expansion in crescent shaped translatable chambers **103** and **113** defined by the orbiting and stationary scrolls. Due to the relationship between the orbiting and stationary scrolls, where the orbiting scrolls **101** and **111** are mounted to eccentric, or offset, ends **121** and **122** (preferably in the form of axially extending pins) of shaft **120** and secured by a conventional coupling device, such as a ball-ring assembly or Oldham coupling (neither of which are shown), they orbit, rather than rotate, about the stationary scrolls **102** and **112**, which are fixed to end walls **104** and **114**. The linkage between the scrolls, eccentric ends, coupling and shaft permits the shaft to convert the scroll orbital motion into rotational motion in the shaft **120**. The rotational movement in shaft **120** can be used to turn a field-generating rotor **80A** of electric generator **80**, where rotor **80A** could be either mounted directly to shaft **120**, as shown in the figure, or to a disk (not shown), which in turn is mounted to shaft **120**. A complimentary stator coil **80B** is mounted in inductive proximity to the field-generating rotor **80A** such that when the field-generating rotor **80A** moves with respect to the stator coil **80B**, an electric current is set up in the windings of the coil **80B**, thereby generating a secondary source of electrical power. In a preferred embodiment, the stator coil **80B** is mounted on an internal surface of hermetically sealed power module **71**, and is electrically connected to an external current carrier through electrically conductive lines **79**. As specifically shown in **FIG. 3B**, a heat exchange passage **150** with fluid inlet **157** and outlet **156** is mounted adjacent stator coil **80B** such that the two are in thermal communication with one another for keeping the stator coil **80B** from overheating. The use of this arrangement is especially warranted when the expander **30A**, **30B** is enclosed within a hermetic shell, where normal convective cooling routes are either minimal or nonexistent. The working fluid is shown in **FIG. 1** as the coolant for the stator coil, but other fluids could be utilized given inlet and outlet ports through the hermetic shell. For example, cooling water passing through condenser **40** via inlet **40A** and outlet **40B** could be routed in place of the working fluid.

[0048] In an alternative embodiment **200** of the invention, as shown in **FIG. 4**, in addition to compressor **202**, fuel supply **203**, turbine **205**, generator **206**, turbine exhaust duct **207**, and shaft **208**, the prime mover subsystem **201** includes a catalytic combustor **204** to promote low emission burning of the fuel/air mixture. The catalytic combustor **204** requires the air entering into it from the compressor **202** to be of sufficiently high temperature to promote the catalysis of combustion byproducts by a noble metal-coated ceramic combustion core (not shown). Thus, a recuperator **215** is added between the turbine exhaust duct **207** and heat energy utilization subsystem evaporator **260** to preheat the compressed air going from compressor **202** to catalytic combustor **204**. Recuperator **215** is essentially a two-circuit heat exchanger that accepts, on its first circuit, inlet from the compressor **202** discharge, and on its second circuit, exhaust gas from the turbine exhaust duct **207**. By way of example,

the temperature entering into the catalytic combustor needs to be between 900° F. and 1000° F. to promote adequate catalysis of the combustion byproducts. The recuperator **215** can be used to supply these needs while at the same time utilizing otherwise wasted exhaust gas from the prime mover subsystem **201**. Heat energy utilization subsystem **210** includes, in a configurational arrangement similar to previous embodiment **10**, a working fluid traversing first thermal circuit **220** that passes through expander **230** (represented notionally in the figure by a single spiral wrap member pair), condenser **240**, pump **250** and evaporator **260**. Throttle valve **272** regulates the amount of working fluid that enters the scroll of expander **230**. The present embodiment may further include hermetically sealed power, condenser, pump and evaporator modules **271**, **241**, **251** and **261**, respectively, as well as dedicated lubrication loop with pump **275** and circuit **277**, in a manner configurationally similar to that depicted in **FIG. 1**. Power output **279** is shown as electric potential coming off a load absorbing device **280**, which is preferably in the form of a generator.

[0049] An alternate embodiment **300** of the system shown in **FIG. 4** with catalytic combustor and recuperator is shown in **FIG. 5**. One of the requirements peculiar to the system including a recuperator to heat up a catalytic combustor is that the heat stream used to charge the working in[] fluid in the heat energy utilization subsystem could benefit from additional thermal content, as the recuperator depletes the energy available from that heat stream or during start-ups. This can be accomplished through the addition of an auxiliary burner **348** and blower **347**, which are placed upstream of the recuperator **315** to provide both preheated intake air into the catalytic combustor **304** as well as a high thermal content heat stream to the heat energy utilization subsystem **310** through auxiliary burner exhaust line **349**. Auxiliary burner **348** mixes low pressure fuel at line pressures typical of small commercial applications (approximately 5 to 20 in. water column) from secondary fuel supply **303B** with exhaust gas from the turbine exhaust **307** to create high temperature air to exchange heat in the evaporator **360** with the working fluid flowing through first thermal circuit **320**. One advantage of the system shown in the present figure is that the size of the recuperator **315** can be reduced, as the added thermal content from auxiliary burner **348** can provide adequate energy to evaporator **360**, even after giving up some of its heat in recuperator **315**. Another advantage relates to the use of the blower itself, which can enhance overall system flexibility by providing sufficient airflow to the heat energy utilization subsystem **310**, even if the prime mover **301** is not operative, which can occur during stand-alone operation of heat energy utilization subsystem **310**. In other regards, the configuration of the elements in the prime mover subsystem **301**, including compressor **302**, primary fuel supply **303A**, catalytic combustor **304**, turbine **305**, generator **306**, turbine exhaust **307**, shaft **308**, recuperator **315**, as well as the elements in the heat energy utilization subsystem **310**, including working fluid traversing first thermal circuit **320**, expander **330**, condenser **340**, pump **350**, evaporator **360** and throttle valve **372**, are similar to that of previous embodiment **200**. Hermetically sealed power, condenser, pump and evaporator modules **371**, **341**, **351** and **361**, respectively, are shown in a manner configurationally similar to that depicted in **FIGS. 1 and 4**.

[0050] In still another embodiment **400** of the invention, as shown in **FIG. 6**, it can also be seen that the turbine

exhaust **407**, in a path similar to that of embodiment **200**, passes through both a recuperator **415** and auxiliary burner **448**. In contrast with the previous embodiment, the auxiliary burner **448** does not exchange any of its heat in the recuperator **415**, instead injecting increased thermal content downstream and entirely in series with the heat stream leaving the recuperator **415**. This configuration has the advantages that a smaller auxiliary burner **448** can be used, and that no additional blower (such as was shown in the previous embodiment) is required. This method of adding thermal content to the prime mover heat stream requires sufficient oxygen content in the heat stream to support combustion. As before, the configuration of the elements in the prime mover subsystem **401**, including compressor **402**, primary fuel supply **403A**, catalytic combustor **404**, turbine **405**, generator **406**, turbine exhaust **407**, shaft **408**, recuperator **415**, as well as the elements in the heat energy utilization subsystem **410**, including working fluid traversing first thermal circuit **420**, expander **430**, condenser **440**, pump **450**, evaporator **460** and throttle valve **472**, are similar to that of previous embodiments. As with the previous embodiments, the heat energy utilization subsystem includes a power module **471**, evaporator module **461**, pump module **451** and condenser module **441**.

[0051] The embodiment **500** is shown in FIG. 7, and is a variation of the embodiment shown in FIG. 6. The major difference between the two embodiments relates to the placement of auxiliary burner **548**, which is now upstream of the recuperator **515** such that it is disposed between turbine **505** and recuperator **515**. As with the previous embodiment, the series relationship between the recuperator **515** and the auxiliary burner **548** obviates the need for a separate blower, while the heat generated in auxiliary burner exhaust line **549** can provide a heat stream to add to that of turbine exhaust **507**. An advantage of this approach, similar to that of the embodiment shown in FIG. 5, is that by adding heat to one of the heat exchange circuits passing through the recuperator **515**, the size of the recuperator **515** can be reduced.

[0052] Referring now to FIG. 8, a variation on the embodiment of FIG. 1 is shown, wherein the output from expander **630** could be routed to one or more heat recovery modules **644**, **646**, **647** which in CHP operation could provide heated water, air or other fluid medium for related process and thermal transport requirements. The modules of the CHP configuration can be used individually or in combination with one another. The first, high temperature heat recovery module **644** (in effect a condenser), is connected to thermal circuit **620** downstream of evaporator **660**, but prior to an expander **630**, in order to extract heat from the working fluid at its generally hottest condition. The high temperature heat recovery module **644**, which can be configured as a simple co-flow heat exchanger, could be for handling very hot water for sterilization, such as may be used as at a restaurant or laundry. It can also be configured as a coil in a storage water tank, such that it could also be used for DHW. The second, low temperature heat recovery module **646** connects to the thermal circuit **620** after the working fluid has given up a portion of its energy to the expander **630** in power module **671**, and can be placed either upstream of the condenser **641**, or, as shown in the figure, connected to the cold side circuit. Low temperature heat recovery module **646** can be, for example, a DHW storage tank, in which cold water enters through inlet **646A** and hot water exits through

outlet **646B**. The third heat recovery module **647** can be connected in parallel to low temperature heat recovery module **646** to act as an SH heat exchanger, such as a radiator, where heat from the secondary circuit of condenser **640** can thermally interact with a fluid in the SH loop that enters via inlet **647A** and exits via outlet **647B**.

[0053] Referring now to FIGS. 9 and 10, an embodiment of the heat energy utilization subsystem **710** is shown with two variants of quick-start features incorporated therein. In the first variant, shown in FIG. 9, an energy storage device, such as an electric battery **792**, is electrically connected to a logic and control module **790**, which in turn is signally connected to each of an auxiliary burner **748**, pump **750**, prime mover subsystem **701** and load absorption device, preferably in the form of a generator **780**, via signal carriers **790a-d**. Power module **771** is made up of at least expander **730**, desuperheating heat exchanger **770** and generator **780**. To initiate heat energy utilization subsystem **710** operation, battery **792** is turned on to energize the logic and control module **790**, which in turn sends current through one or more signal carriers **790a-d** to start the pump **750**, auxiliary burner **748** and generator **780** in accordance with user-defined power requirements. In addition, logic and control module **790** can send control instructions to the prime mover subsystem **701** to ensure coordination between the two subsystems. The auxiliary burner **748**, upon initiation, burns fuel to generate a heat stream that is introduced into turbine exhaust **707** and expander **760** through auxiliary burner exhaust line **749**. After initiation of heat energy utilization subsystem **710** operation, either the prime mover subsystem **701** operation can be commenced, or the auxiliary burner **748** can continue to provide sufficient heat stream thermal content through a heat energy utilization subsystem stand-alone mode of operation. Note that although the presently shown embodiment does not have the heat stream generated by the auxiliary burner **748** cooperating with a recuperator (as shown in FIGS. 5-7), such configuration is within the scope of the present invention. In addition to generating useful work **779** (shown in the figures as electric potential), generator **780** provides, through recharging module **791**, the ability to recharge the battery **792**. One advantage of the quick-start approach is that the benefits of the heat energy utilization subsystem **710** can be realized immediately, rather than waiting for it to catch up with the already-operating prime mover subsystem **701**. A second advantage of the quick-start feature is that in low-power and rapidly fluctuating dynamic power requirements, where it would be impractical to start the prime mover subsystem **701**, the heat energy utilization subsystem **710** could be the sole provider of power. Desuperheating heat exchanger **770** is fluidly connected to the outlet of the secondary circuit of condenser **740** to provide additional heat output from the system and provide a lower temperature environment around the generator **780** windings. The heat output from condenser **740** and desuperheating heat exchanger **770** is potentially useful for SH or DHW (neither of which are presently shown). The desuperheating heat exchanger **770** can provide a higher temperature output from the overall system compared to a condenser-only configuration. The quantity of heat may well be the same in both configurations, but by separating the heat exchange process into two pieces, (desuperheater and condenser), a higher fluid temperature may result. Desuperheating heat exchanger **770** must be in heat exchange communication with the vapor leaving the expander **730**,

possibly by having desuperheating heat exchanger **770** situated inside the shell of power module **771** and having open flow from the exit port of the expander **730** into the power module **771** shell.

[0054] In the second variant, shown in **FIG. 10**, an accumulator **796** and accumulator control valve **797** (which could be a conventional solenoid-based valve) are added upstream of the evaporator **760** in turbine exhaust **707**. Isolation valve **798** is placed in front of evaporator **760** such that during heat energy utilization subsystem **710** startup, the hot exhaust coming from auxiliary burner **748** can be routed to accumulator **796** to charge it prior to normal heat energy utilization subsystem **710** operation. Alternatively, accumulator **796** may be precharged during the previous system shut-down such that it retains this heat until the next start-up sequence of heat energy utilization subsystem **710**. The residual heat and pressure content of the fluid in the accumulator **796** can thus function as a power delivery smoothing device, in that it can be used in place of the auxiliary burner **748** or the prime mover **701** for brief intervals, thus saving on fuel and wear and tear on the equipment that would otherwise be continuously cycled. Logic and control module **790** has, in addition to signal carriers **790a-d**, an additional electrical connection **799** to the accumulator control valve **797** to control the flow of working fluid in first thermal circuit **720**. Thus, accumulator control valve **797** and isolation valve **798** are used to control heating fluid flow during subsystem **710** starting, while the throttle valve **772** controls working fluid flow during normal operation of subsystem **710**. Partial actuation of valves **797** and **798** allow both power generation and recharging of accumulator **796**. The inclusion of the accumulator **796** and related valves **797** and **798** permits even more rapid heat energy utilization subsystem **710** starting, which improves overall power generation subsystem **700** efficiency.

[0055] Referring now to **FIG. 11**, a block diagram of the load-splitting module **810** for the integrated power generation system is shown. Load-splitting module **810** continually monitors the status of the power generation patterns **820** and **830** from both the heat energy utilization subsystem (not shown) and the prime mover subsystem (not shown). Active feedback features in the load-splitting module **810** compare the power generation pattern information to predetermined load parameters, and adjust as needed the output between the two power-generating subsystems to promote load dynamics isolation. Plot **850** is a representation of an optimized composite electric generation profile under load-splitting module operation. The heart of the load-splitting module is a fuzzy logic controller **840**, that incorporates multivalued logic to process sensed values, then provides active feedback control features to set the load requirements in the prime mover and heat energy utilization subsystems so that the electrical end user is delivered power in the most efficient, cost effective manner. The fuzzy logic controller **840** has as its primary functions the separation of an electrical load into two parts (a steady portion and a dynamic portion), and the outputting of two power control signals (a slow response signal and a fast response signal).

[0056] Fuzzy logic controller **840** responds to instantaneous values of load and to recent average values of load to form a likely history of loads that can be generalized according to factors such as load current, load voltage, power factor, input of basic system characteristics (such as

a table of information for system set-up parameters), and history of recent loads, seasonal (calendar) and time-of-day attributes, or the like so that future loads can be anticipated to a useful extent. Once the fuzzy logic controller **840** of load-splitting module **810** generates the likely value of steady load for the next interval of time, it can then determine how much load can be apportioned to each of the heat energy utilization and prime mover subsystems. The nature of the two cooperative subsystems is such that the prime mover subsystem is relatively more efficient but slower in response to load fluctuations, while the heat energy utilization subsystem is more rapidly responsive, although less efficient. The load the system responds to includes a base component that changes slowly, if at all, and a dynamic component. To maximize efficiency of operation of the overall system, the prime mover should be operated as often as possible, but not so much that it must make frequent changes to its output. A first output from the fuzzy logic controller **840** can function as the throttle setting for the prime mover such that the torque, but not the speed, voltage, or frequency of the prime mover are varied. A second output from the controller **840** can be coupled to the fast response heat energy utilization subsystem such that speed control is maintained by adjusting the throttle. In situations where the two power generators are both generating electric output, and are connected in parallel with the same load, they will stay synchronized with one another as they follow the load. The controller **840** can be programmed so that it would always maximize the load on the more efficient prime mover generator, consistent with the need to not make any rapid load changes on it, but also protective against situations leading to overload of the entire system. Through the fuzzy algorithm, the most efficient steady load distribution is produced, while the unsteady load swings of the lesser efficient but more rapidly controllable heat recovery subsystem are kept to a level that is always within the capability of that system. Either artificial intelligence or user preprogramming can be used to assist the fuzzy logic controller **840** to anticipate load changes in both extent and timing.

[0057] Although the basics of the fuzzy logic controller **840** were first developed for use with the heat energy utilization system in this application, the characteristics of controller **840** make it potentially applicable to a power and heat system using a fuel cell and a thermally driven engine of any sort which provides more rapid response to load changes than does a fuel cell. Fuel cells often have waste heat which can be utilized in many ways; however, fuel cells tend to be slow to respond to load changes, which can be very rapid in practical applications. While batteries, flywheels or the like may be used to smooth normal load changes for a fuel cell system, these add-on technologies have their own limitations, in addition to contributing to overall system cost and complexity. By coupling a fast response generator as part of the heat energy utilization system to the fuel cell, the system can achieve the significant response advantages associated with the aforementioned load-smoothing devices, without the negative impacts on system compactness, operating time, weight, cost or maintenance. As with a system that employs a microturbine-based prime mover, the fuzzy logic controller **840** can be used to parse out the loads among the two subsystems, a fuel cell that can only be loaded and unloaded slowly, and the supplemental heat energy utilization subsystem capable of fast load changes. The controller **840** takes data on recent

load profiles and outputs two load signals, a relatively steady one to the fuel cell and the other which has all the rapid load changes to the heat energy utilization subsystem acting in its peaking capacity. The controller **840** limits the load on the peaking system to loads which are likely to be within its capacity, thus placing as much of the load as possible on the more efficient fuel cell.

[0058] Referring now to **FIG. 12**, capacity control is achieved with heat energy utilization subsystem **910** that includes two separate controllers made up of speed-throttle control under rapid response portion **911** and evaporator-pump-waste gate valve control under slow response portion **915**. Together, rapid and slow response portions **911**, **915** respectively, comprise capacity control module **919**. In the rapid response portion **911**, shaft speed coming off expander **930** of power module **971** is sensed by sensors **985A** in close-coupled control mechanism **985**, which sends a signal via feed-back controller **985B** to throttle valve **972** to adjust valve position, thus effecting rapid and robust shaft speed correction and control to the dynamic load being imposed on the heat energy utilization subsystem **910**. In the slow response portion **915**, a PID logic controller **990**, which, in response to pressure and temperature signals **961**, **962** corresponding to evaporator **960** conditions (collectively known as superheat), sends out actuation signals **994a-c** to control the pump **950**, auxiliary burner **948** (with secondary fuel supply **903B**) and prime mover turbine exhaust **907** through waste heat bypass valve **995** coming from the prime mover subsystem **901**. By actively adjusting the flow rate through pump **950** and waste gate valve **995** position, as well as optional firing of the auxiliary burner **948** and introduction into auxiliary burner exhaust line **949** of additional heat, the slower, system-level control of slow response portion **915** promotes the acquisition and maintenance of an equilibrium point for heat energy utilization subsystem **910** by smoothly adjusting individual component settings with the PID logic controller **990**. In addition, time rate of change information from generator **980** can be fed through power signal **981** into the PID controller **990**, thus providing additional control logic capability to the heat energy utilization subsystem **910**. Considerable increases in both heat energy utilization subsystem **910** as well as overall system **900** flexibility can be realized by permitting the heat energy utilization subsystem **910** to respond to volatile load changes, thereby increasing the efficiency of the prime mover subsystem **901**. In addition, fuzzy logic controller **940** can be used in a manner similar to that of the previous embodiment, to ensure adequate load splitting among the heat energy utilization and prime mover subsystems, **910** and **901** respectively.

[0059] While the embodiments and systems discussed herein have been directed to particular embodiments of a prime mover subsystem coupled with a heat energy utilization subsystem, it is within the scope of the present invention to provide an adaptable operating system incorporating features responsive to varying user demands. Furthermore, although the preferred embodiments incorporate a microturbine prime mover as the heat stream generating source, it is within the scope of the invention to adapt the heat energy utilization subsystem to fit with any prime mover, including conventional reciprocating, steam and gas turbine engines, as well as non-combustion based and renewable prime mover sources, so long as the prime mover heat stream possesses sufficient thermal content. Thus, having described

the present invention in detail and by reference to the embodiments thereof, it will be apparent that modifications and variations are possible without departing from the scope of the invention in the following claims.

What is claimed is:

1. A heat energy utilization system comprising:
 - a thermal circuit;
 - a pump to circulate a working fluid through said thermal circuit;
 - a power module comprising:
 - an expander; and
 - a load absorption device coupled to said expander such that at least a portion of the energy produced by the expansion of said working fluid in said expander operates said load absorption device;
 - a first heat exchanger including:
 - a first inlet and a first outlet together in fluid communication with said thermal circuit; and
 - a second inlet and a second outlet together in heat exchange relationship with said thermal circuit; and
 - a second heat exchanger, wherein said pump, power module, first heat exchanger and second heat exchanger are connected via said thermal circuit so as to be in fluid communication with one another such that, upon exchange of heat in said first heat exchanger, the increase in energy content in said working fluid is converted to useable work in said load absorption device.
2. A heat energy utilization system according to claim 1, wherein said second inlet in said first heat exchanger is configured to accept an externally supplied heat stream.
3. A heat energy utilization system according to claim 2, wherein said power module is hermetically sealed.
4. A heat energy utilization system according to claim 3, further comprising:
 - a lubricant pump disposed within said power module and operatively responsive to said expander; and
 - a lubricant circuit in fluid communication with said lubricant pump, said lubricant circuit including a lubricant droplet separator, such that upon operation of a lubricant pump, said lubricant circuit can circulate a lubricant within said power module.
5. A heat energy utilization system according to claim 4, further comprising a desuperheating heat exchanger disposed within said power module, said desuperheating heat exchanger in thermal communication with said expander, whereby said desuperheating heat exchanger reduces the thermal content of fluid exiting said expander.
6. A heat energy utilization system according to claim 5, wherein said load absorption device is a generator comprising:
 - a field-generating rotor; and
 - a stator coil mounted to said hermetically sealed power module so that upon movement of said field-generating rotor, it electrically interacts with said stator coil to produce an electric potential.

7. A heat energy utilization system according to claim 6, wherein said thermal circuit is a closed loop.

8. A heat energy utilization system according to claim 1, wherein said working fluid is an organic refrigerant.

9. A heat energy utilization system according to claim 6, wherein said expander is a scroll device defined by a scroll housing, said scroll device including at least one scroll pair comprising a pair of involute spiral wrap members and a rotatable shaft coupled to said at least one scroll pair such that the expansion of said working fluid through said at least one scroll pair causes said rotatable shaft to rotate.

10. A heat energy utilization system according to claim 9, wherein said field-generating rotor is rotatably coupled to said rotatable shaft.

11. A heat energy utilization system according to claim 9, further comprising a second scroll pair coupled to said first pair through said rotatable shaft.

12. A heat energy utilization system according to claim 11, further including at least one process heat utilization module in thermal communication with said thermal circuit, said process heat utilization module configured to provide process heat to an external user.

13. A heat energy utilization system according to claim 12, wherein said at least one process heat utilization module includes a first process heat utilization module and a second process heat utilization module, said first process heat utilization module configured to extract higher temperature energy than said second process heat utilization module.

14. A heat energy utilization system according to claim 1, further comprising an auxiliary burner in thermal communication with said heat stream.

15. A heat energy utilization system according to claim 14, further comprising:

a logic and control module in signal communication with each of said load absorption device, auxiliary burner, pump, and adapted to be in signal communication with said heat stream;

an energy storage device in electrical communication with said logic and control module; and

a recharging module in electrical communication with said load absorption device and said energy storage device such that said logic and control module is configured to initiate a start-up sequence for said heat energy utilization subsystem, and said recharging module recharges said energy storage device during normal operation of said heat energy utilization system.

16. A heat energy utilization system according to claim 15, wherein said energy storage device is an electrical battery.

17. A heat energy utilization system according to claim 16, further comprising:

an accumulator in fluid communication with said first heat exchanger and expander to collect and store at least a portion of excess energy from said heat stream;

a control valve in fluid communication with said accumulator; and

an isolation valve disposed within said thermal circuit, said isolation valve to be used to selectively isolate said first heat exchanger from said expander,

whereby, upon initiation and subsequent operation of said heat energy utilization system, it is capable of sustained operation.

18. A heat energy utilization system adapted to be coupled to a heat source, said heat energy utilization system comprising:

a thermal circuit;

a pump to circulate a working fluid through said thermal circuit;

a hermetically sealed power module operating as a scroll expander, said hermetically sealed power module comprising:

a scroll housing;

a plurality of scroll pairs mounted in said scroll housing, each of which includes a pair of meshed axially extending involute spiral wrap members;

a rotatable shaft coupled to said plurality of scroll pairs such that the expansion of said working fluid through said plurality of scroll pairs causes said rotatable shaft to rotate;

a throttle valve disposed in said thermal circuit to permit a predetermined amount of said working fluid to enter said scroll expander; and

a generator operatively responsive to said rotatable shaft to produce work;

a first heat exchanger including:

a first inlet and a first outlet together in fluid communication with said thermal circuit; and

a second inlet and a second outlet together in heat exchange relationship with said first inlet and outlet; and

a second heat exchanger, wherein said pump, first heat exchanger, expander and second heat exchanger are connected via said thermal circuit so as to be in fluid communication with one another such that, upon exchange of heat between said first inlet and outlet and said second inlet and outlet, the increase in energy content in said working fluid is converted to electric potential in said generator.

19. A power generation system for providing a primary and secondary source of output power comprising:

a prime mover subsystem including:

means for generating a primary source of power; and

means for generating a heat stream; and

a heat energy utilization subsystem for coupling to said prime mover subsystem, said heat energy utilization subsystem including:

a thermal circuit;

a pump to circulate a working fluid through said thermal circuit;

a power module comprising:

an expander;

a load absorption device coupled to said expander such that at least a portion of the energy produced by the expansion of said working fluid operates to produce power;

a first heat exchanger including:

a first inlet and a first outlet together in fluid communication with said thermal circuit; and

a second inlet and a second outlet together in heat exchange relationship with said first inlet and outlet; and

a second heat exchanger for cooling said working fluid,

wherein said pump, first heat exchanger, expander and second heat exchanger are connected via said thermal circuit so as to be in fluid communication with one another such that, upon introduction of said heat stream from said prime mover, at least a portion of the increase in energy content in said working fluid produces useable work in said load absorbing device.

20. A power generation system according to claim 19, further including a throttle valve disposed in said thermal circuit to permit a predetermined amount of working fluid to enter said expander.

21. A power generation system according to claim 20, wherein said power module is hermetically sealed in a hermetic shell.

22. A power generation system according to claim 21, further comprising an auxiliary burner in thermal communication with said heat stream to augment the thermal content of said heat stream.

23. A power generation system of claim 22, further comprising:

a logic and control module in electrical communication with each of said generator, auxiliary burner, pump, and means for generating a primary source of power;

an energy storage device in electrical communication with said logic and control circuit; and

a recharging module in electrical communication with said generator and said energy storage device such that said logic and control module can initiate a start-up sequence for said heat energy utilization subsystem, and said recharging module recharges said energy storage device during normal operation of said power generation system.

24. A power generation system according to claim 23, wherein said energy storage device is an electrical battery.

25. A power generation system according to claim 24, further comprising:

an accumulator in fluid communication with said first heat exchanger and expander to collect and store at least a portion of excess thermal energy from said heat stream;

a control valve in fluid communication with said accumulator; and

an isolation valve disposed within said thermal circuit, said isolation valve to be used to selectively isolate said first heat exchanger from said expander.

26. A power generation system according to claim 25, further comprising a capacity control module to facilitate the responsiveness of said heat energy utilization subsystem, said capacity control module comprising:

a speed sensor coupled to said expander;

a feed-back controller operatively responsive to a signal from said speed sensor so as to actuate said isolation valve;

a bypass valve disposed within said heat stream to control the flow of said heat stream into said first heat exchanger module;

a plurality of sensors disposed in said thermal circuit to measure said working fluid temperature and pressure; and

a proportional integral differential logic controller to control said bypass valve, said pump and said auxiliary burner based on first heat exchanger sensor input signals.

27. A power generation system according to claim 26, wherein said speed sensor and feed-back controller are packaged within said hermetic shell of said power module.

28. A power generation system according to claim 27, further comprising a load splitting module to analyze and respond to varying load conditions such that it causes said prime mover subsystem and said heat energy utilization subsystem to provide substantially uniform and dynamic load components, respectively, to the composite electric generation profile.

29. A power generation system according to claim 28, wherein said load splitting module includes a fuzzy logic controller.

30. A power generation system according to claim 19, further comprising:

a lubricant pump disposed within said power module and operatively responsive to said expander; and

a lubricant circuit in fluid communication with said lubricant pump, said lubricant circuit including a lubricant droplet separator, such that upon operation of said lubricant pump, said lubricant circuit can circulate a lubricant within said power module.

31. A power generation system according to claim 19, further comprising a desuperheating heat exchanger disposed within said power module, said desuperheating heat exchanger in thermal communication with said expander, whereby said desuperheating heat exchanger reduces the thermal content of said working fluid exiting said expander.

32. A power generation system according to claim 19, wherein said load absorption device is a generator comprising:

a field-generating rotor; and

a stator coil mounted to said hermetically sealed power module so that upon movement of said field-generating rotor, it electrically interacts with said stator coil to produce an electric potential.

33. A power generation system according to claim 19, wherein said thermal circuit is a closed loop.

34. A power generation system according to claim 19, wherein said working fluid is an organic refrigerant.

35. A power generation system according to claim 19, further including at least one process heat utilization module

in thermal communication with said thermal circuit, said process heat utilization module configured to provide process heat to an external user.

36. A power generation system according to claim 35, wherein said at least one process heat utilization module includes a first process heat utilization module and a second process heat utilization module, said first process heat utilization module configured to extract higher temperature energy than said second process heat utilization module.

37. A power generation system according to claim 19, wherein said prime mover subsystem is a fuel cell.

38. A power generation system according to claim 19, wherein said prime mover subsystem is a microturbine.

39. A power generation system according to claim 38, where said microturbine further comprises a recuperator in thermal communication with said means for generating a heat stream, said recuperator adapted for preheating air prior to combustion of said air in said prime mover subsystem.

40. A power generation system according to claim 39, wherein said combustion takes place in a catalytic combustor.

41. A power generation system according to claim 19, wherein said expander of said heat energy utilization subsystem is a scroll device, and includes a scroll housing that contains at least one pair of meshed axially extending involute spiral wrap members and a rotatable shaft coupled to said at least one scroll pair such that the expansion of said working fluid through said at least one scroll pair causes said rotatable shaft to rotate.

42. A power generation system according to claim 41, further comprising a second scroll pair of meshed axially extending involute spiral wrap members coupled to the first scroll pair of said at least one scroll pair.

43. An integrated power generation system for providing a primary and secondary source of power, comprising:

- a microturbine subsystem configured to generate a heat stream; and

- a heat energy utilization subsystem coupled to said microturbine, providing said secondary source of power, including:

- a closed-loop thermal circuit;

- a pump to circulate a working fluid through said thermal circuit;

- a first heat exchanger including:

- a first inlet and outlet for said closed-loop thermal circuit;

- a second inlet and outlet in heat exchange relationship with said first inlet and outlet, said second inlet and outlet in fluid communication with said heat stream;

- a hermetically sealed power module comprising:

- a scroll expander to convert the energy in said working fluid discharged from said first heat exchanger; and

- a load absorption device coupled to said scroll expander such that at least a portion of the energy produced by the expansion of said working fluid in said scroll expander operates said load absorption device to produce work; and

- a second heat exchanger in fluid communication with said scroll expander, wherein said pump, first heat exchanger, expander and second heat exchanger are connected via said thermal circuit so as to be in fluid communication with one another such that, upon introduction of said heat stream into said second inlet and outlet, the increase in energy content in said working fluid is converted to useable work in said load absorbing device.

44. An integrated power generation system according to claim 43, further including a throttle valve disposed in said thermal circuit to permit a predetermined amount of working fluid to enter said expander.

45. An integrated power generation system according to claim 43, wherein said load absorbing device is a generator rotatably responsive to said rotatable shaft to produce an electric potential.

46. An integrated power generation system according to claim 43, where said microturbine subsystem further comprises a recuperator in thermal communication with said heat stream such that during microturbine operation, said recuperator preheats air prior to combustion of said air in said microturbine subsystem.

47. An integrated power generation system according to claim 46, wherein said microturbine subsystem includes a catalytic combustor.

48. An integrated power generation system according to claim 43, wherein said heat energy utilization subsystem further comprises an auxiliary burner in thermal communication with said heat stream to augment the thermal content thereof.

49. An integrated power generation system according to claim 43, further comprising:

- a lubricant pump disposed within said power module and operatively responsive to said expander; and

- a lubricant circuit in fluid communication with said lubricant pump, said lubricant circuit including a lubricant droplet separator, such that upon operation of said lubricant pump, said lubricant circuit can circulate a lubricant within said power module.

50. An integrated power generation system according to claim 43, further comprising a desuperheating heat exchanger disposed within said power module, said desuperheating heat exchanger in thermal communication with said expander, whereby said desuperheating heat exchanger reduces the thermal content of fluid exiting said expander.

51. An integrated power generation system according to claim 43, further comprising a second pair of meshed axially extending involute spiral wrap members mechanically coupled to said first scroll pair.

52. An integrated power generation system according to claim 43, further including at least one process heat utilization module in thermal communication with said thermal circuit, said process heat utilization module configured to provide process heat to an external user.

53. An integrated power generation system according to claim 52, wherein said at least one process heat utilization module includes a first and second process heat utilization modules, said first process heat utilization module configured to extract higher temperature energy than said second process heat utilization module.

54. An integrated power generation system according to claim 48, further comprising a quick-start mechanism in the heat energy utilization subsystem, said quick-start mechanism comprising:

- a logic and control module in electrical communication with each of said generator, auxiliary burner, pump, and microturbine subsystem;
- a battery in electrical communication with said logic and control module; and
- a recharging module in electrical communication with said generator and said battery such that said logic and control module is configured to initiate a start-up sequence for said heat energy utilization subsystem, and said recharging module recharges said battery during normal operation of said heat energy utilization subsystem.

55. An integrated power generation system according to claim 54, further comprising:

- an accumulator in fluid communication with said first heat exchanger and expander to collect and store at least a portion of excess thermal energy from said heat stream;
- a control valve in fluid communication with said accumulator; and
- an isolation valve disposed within said thermal circuit, said isolation valve to be used to selectively isolate said first heat exchanger from said expander, whereby, upon initiation and subsequent operation of said heat energy utilization system, it is capable of sustained operation.

56. An integrated power generation system according to claim 54, further comprising a capacity control module to facilitate the responsiveness of said heat energy utilization subsystem, said capacity control module comprising:

- a speed sensor coupled to said expander;
- a feed-back controller operatively responsive to a signal from said speed sensor so as to actuate said isolation valve;
- a bypass valve disposed within said heat stream to control the flow of said heat stream into said first heat exchanger module;
- a plurality of sensors disposed in said thermal circuit to measure said working fluid temperature and pressure; and
- a proportional integral differential logic controller to control said bypass valve, said pump and said auxiliary burner based on first heat exchanger sensor input signals.

57. An integrated power generation system according to claim 56, further comprising a load splitting module to analyze and respond to varying load conditions such that it causes said prime mover subsystem and said heat energy utilization subsystem to provide substantially uniform and dynamic load components, respectively, to the composite electric generation profile.

58. An integrated power generation system according to claim 57, wherein said load splitting module includes a fuzzy logic controller.

59. A method of producing power by using a power generation system that has a prime mover subsystem and a secondary power generation subsystem, the method comprising the steps of:

operating said prime mover subsystem to energize a first load absorption device;

arranging at least a pump, first heat exchanger, expander and second heat exchanger to be in fluid communication with one another via circulated working fluid routed through a thermal circuit as part of said secondary power generation subsystem, whereby said first heat exchanger is placed in thermal communication with said prime mover subsystem;

exchanging heat between said prime mover subsystem and said first heat exchanger;

transferring at least a portion of the thermal content of said heat in said first heat exchanger to said working fluid, thereby producing an increase in temperature of said working fluid;

regulating the flow of said working fluid to said expander;

coupling said expander to a second load absorption device;

expanding said working fluid in said expander such that the energy released by said expansion energizes said second load absorption device;

condensing at least a portion of said expanded working fluid in a second heat exchanger; and

pressurizing the condensed portion of said working fluid with a pump coupled to said expander.

60. A method according to claim 59, wherein a throttle valve is used in said step of regulating the flow of said working fluid to said expander.

61. A method according to claim 59, wherein said second load absorbing device is an electric generator.

62. A method according to claim 59, further comprising the step of hermetically sealing said expander and said second load absorption device in a power module.

63. A method according to claim 62, wherein the expander is a scroll expander.

64. A method according to claim 63, wherein said scroll expander includes a plurality of scroll pairs.

65. A method according to claim 59, further comprising the additional step of operating a lubricant pump and a lubricant droplet separator in fluid communication with said lubricant pump, both disposed within said power module and operatively responsive to said expander such that, upon operation of said lubricant pump, a lubricant circulates within said power module.

66. A method according to claim 59, further comprising the additional step of operating a desuperheating heat exchanger disposed within said power module, said desuperheating heat exchanger in thermal communication with said expander such that said desuperheating heat exchanger reduces the thermal content of fluid exiting said expander.

67. A method according to claim 59, wherein the prime mover subsystem comprises a microturbine.

68. A method according to claim 67, comprising the additional step of arranging an auxiliary burner to be in thermal communication with said first heat exchanger.

69. A method according to claim 59, further comprising the additional steps of:

arranging at least one process heat utilization module to be in thermal communication with said working fluid;

extracting at least a portion of the thermal content of said working fluid from said thermal circuit; and

heating a fluid medium in said at least one process heat utilization module with said extracted thermal content.

70. A method according to claim 69, wherein said process heat utilization module is in thermal communication with said working fluid at a location between where said working fluid is discharged from said first heat exchanger and expanded in said expander.

71. A method according to claim 70, wherein said process heat utilization module is in thermal communication with said working fluid at a location between where said working fluid is expanded in said expander and where it enters said second heat exchanger.

72. A method according to claim 71, wherein a first of said at least one process heat utilization module is in thermal communication with said working fluid at a location between where said working fluid is discharged from said first heat exchanger and expanded in said expander, and a second of said at least one heat recovery module is in thermal communication with said working fluid at a location between where said working fluid is expanded in said expander and where it enters said second heat exchanger.

73. A method according to claim 72, further comprising the additional steps of:

inserting elevated temperature and pressure working fluid into an accumulator; and

storing said elevated temperature and pressure working fluid in said accumulator.

74. A method according to claim 68, further comprising the additional step of initiating a start-up sequence in said secondary power generation subsystem by:

providing electric current to a control module;

sending start-up signals from said control module to at least one of said auxiliary burner, said pump, said first heat exchanger or said first load absorption device; and

energizing said thermal circuit by operating said auxiliary burner such that the thermal content produced by said combustor enables the self-sustaining operation of said heat energy utilization subsystem.

75. A method according to claim 68, further comprising the additional step of initiating a start-up sequence in said heat energy utilization subsystem by:

providing electric current to a control module;

sending start-up signals from said control module to at least one of said auxiliary burner, said pump, said isolation valve, said first heat exchanger or said first load absorption device; and

energizing said thermal circuit by releasing said elevated temperature and pressure working fluid stored in said accumulator.

76. A method according to claim 68, further comprising the additional steps of:

providing a load-splitting module that accumulates, through a load-splitting controller, the steady-state and dynamic load requirements of an end-user; and

sending out signals to determine what portion of the supplied power will be supplied by said heat energy

utilization subsystem, and what portion will be supplied by said prime mover.

77. A method according to claim 76, further comprising the additional step of providing a capacity control module that, based on temperature and pressure data gathered from said first heat exchanger, calculates said heat energy utilization subsystem response to changes in power requirements.

78. A method according to claim 76, further comprising the additional step of incorporating a fuzzy logic controller into said load-splitting module, said fuzzy logic controller configured to provide output signals to said prime mover and secondary power generation subsystems.

79. A method of operating a heat energy utilization subsystem using a quick-start mechanism, the method comprising the steps of:

arranging at least a pump, first heat exchanger, expander and second heat exchanger to be in fluid communication with one another via circulated working fluid routed through a thermal circuit;

arranging an auxiliary burner, fuel supply and an auxiliary burner exhaust line such that said auxiliary burner exhaust line is placed in thermal communication with said thermal circuit;

initiating a start-up sequence in said heat energy utilization subsystem by:

providing electric current to a control module;

sending start-up signals from said control module to at least one of said auxiliary burner, said pump, said first heat exchanger or said first load absorption device; and

energizing said thermal circuit by operating said auxiliary burner such that the thermal content produced by said auxiliary burner enables the self-sustaining operation of said heat energy utilization subsystem;

transferring at least a portion of the thermal content of said auxiliary burner exhaust line to said working fluid, said transfer of said thermal content producing an increase in temperature of said working fluid;

regulating the flow of said working fluid to said expander;

expanding said working fluid in an expander such that the energy released by said expansion turns said load absorbing device;

condensing said expanded working fluid in a condenser; and

pressurizing said working fluid with a pump coupled to said expander, whereby said heat energy utilization subsystem is capable of sustained, stand-alone operation.

80. A method according to claim 79, wherein a throttle valve disposed within said first thermal circuit is used in said step of regulating the flow of working fluid to said expander.

81. A method according to claim 79, further comprising the step of hermetically sealing said expander and said first load absorption device in a power module.

82. A method according to claim 81, wherein the expander is a scroll expander.

83. A method according to claim 82, wherein said step of expanding said working fluid is through a plurality of scroll pairs.

84. A method according to claim 82, further comprising the additional step of operating a lubricant pump and a lubricant droplet separator in fluid communication with said lubricant pump, both disposed within said power module and operatively responsive to said expander such that, upon operation of said lubricant pump, a lubricant circulates within said power module.

85. A method according to claim 81, further comprising the additional step of operating a desuperheating heat exchanger disposed within said power module, said desuperheating heat exchanger in thermal communication with said expander such that said desuperheating heat exchanger reduces the thermal content of fluid exiting said expander.

* * * * *