



US 20030093132A1

(19) **United States**

(12) **Patent Application Publication**  
**Eckmiller**

(10) **Pub. No.: US 2003/0093132 A1**

(43) **Pub. Date: May 15, 2003**

(54) **RETINAL IMPLANT WITH IMPROVED  
IMPLANTATION AND WORKING  
PROPERTIES**

**Publication Classification**

(51) **Int. Cl.<sup>7</sup> ..... A61N 1/18**

(52) **U.S. Cl. .... 607/54**

(76) **Inventor: Rolf Eckmiller, Neuss (DE)**

Correspondence Address:  
**VENABLE, BAETJER, HOWARD AND  
CIVILETTI, LLP  
P.O. BOX 34385  
WASHINGTON, DC 20043-9998 (US)**

(57) **ABSTRACT**

The invention relates to a retinal implant having at least one functional unit 4 positioned internally inside an eye and at least one functional unit (2) positioned externally outside the eye and at least one functional unit 8 positioned outside the eye, which are separably connected to one another via a signal path (5, 6, 7, 15, 16, 17; 10, 11, 12, 15, 16, 17) in a manner designed for signal or data transmission. The patient's residual vision which may still remain is preserved because the signal path extends through the sclera (9) of the eye and does not incorporate the anterior eye section.

(21) **Appl. No.: 10/056,208**

(22) **Filed: Jan. 28, 2002**

(30) **Foreign Application Priority Data**

Nov. 9, 2001 (DE)..... 10154700.5

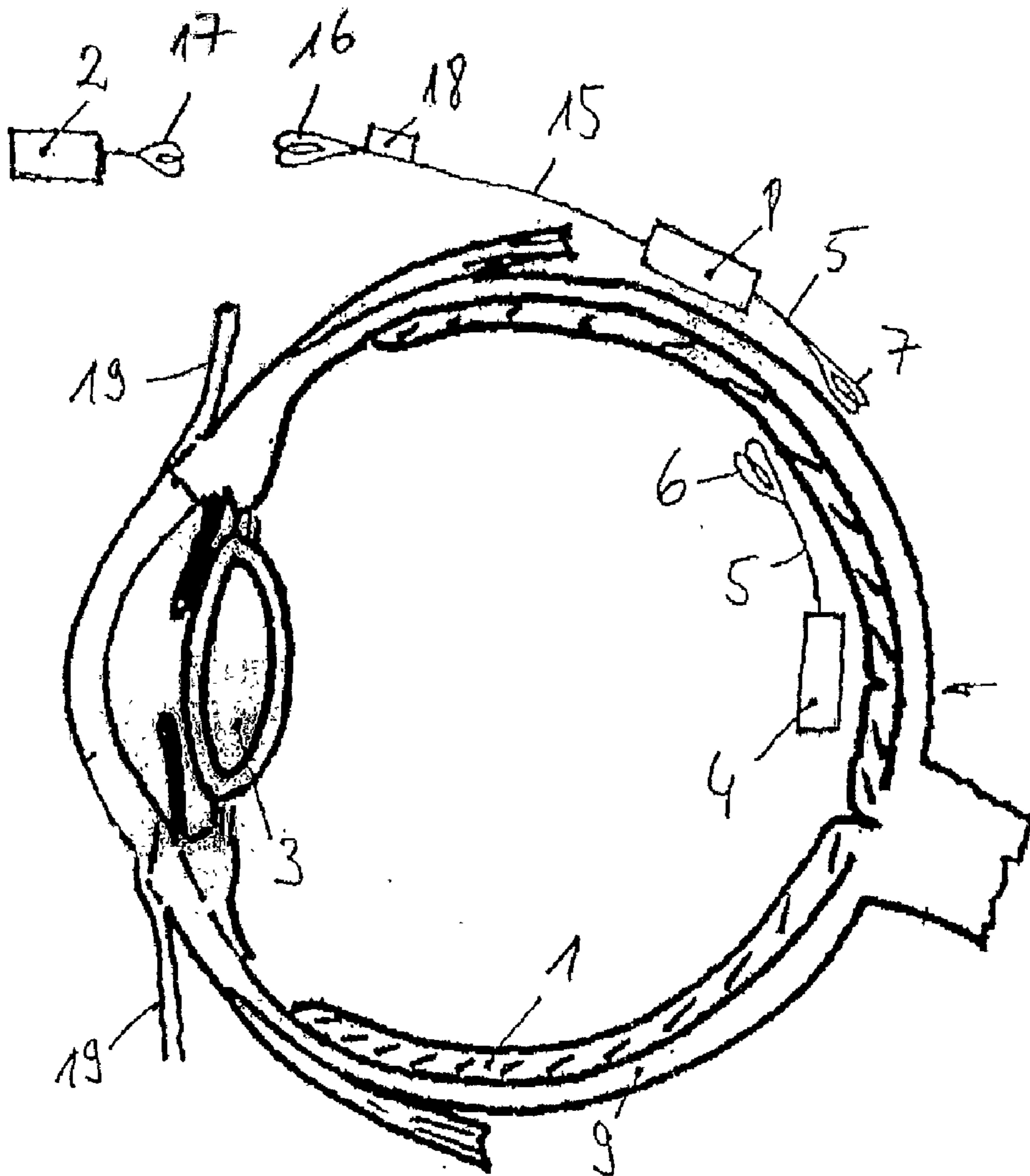

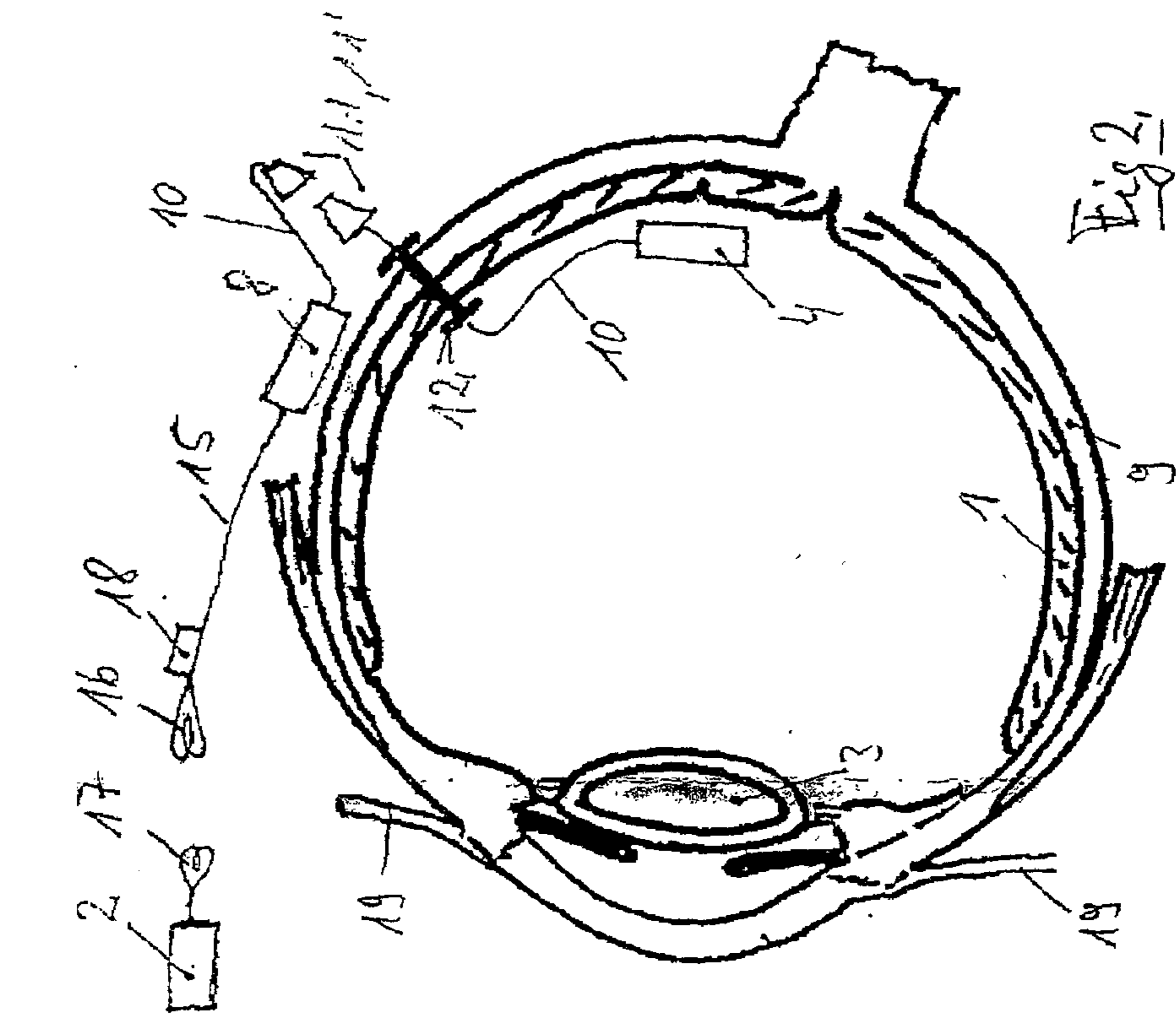

Fig. 1

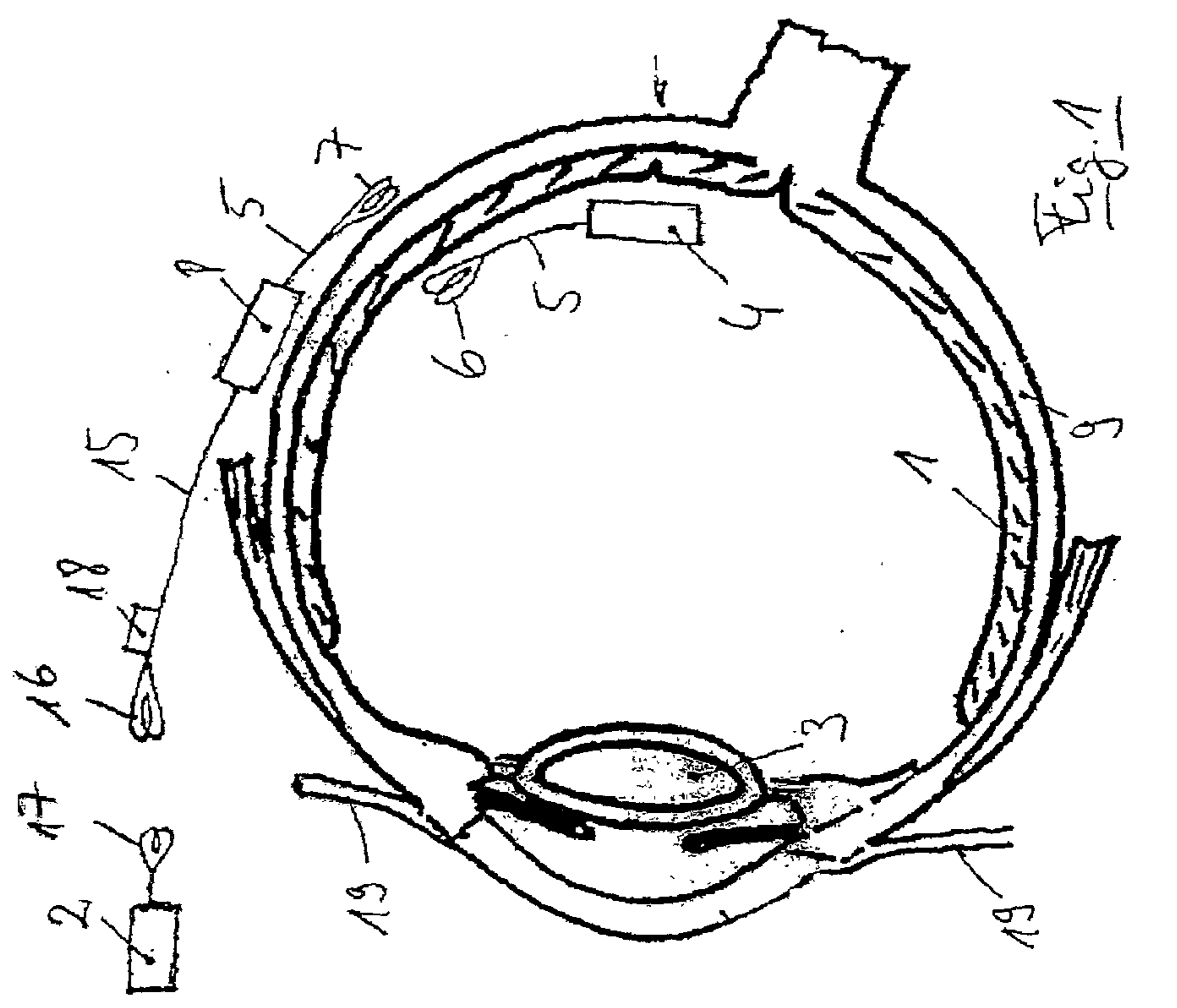

Fig. 2

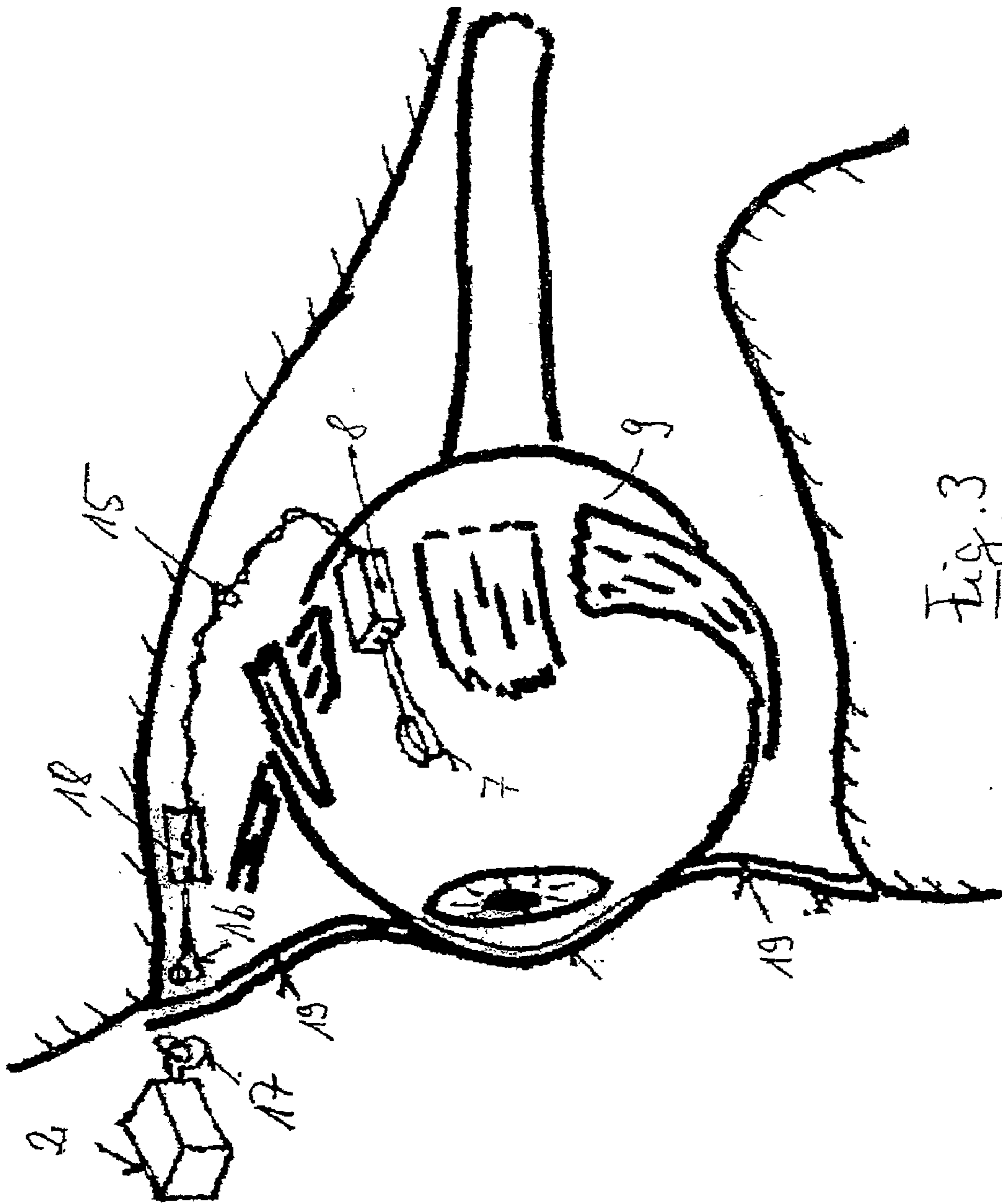

Fig. 3



### RETINAL IMPLANT WITH IMPROVED IMPLANTATION AND WORKING PROPERTIES

[0001] The present invention relates to a retinal implant having the features of the precharacterising clause of claim 1.

[0002] An implant according to the generic type is known from U.S. Pat. No. 5,935,155. This document proposes that a functional unit (IGF) positioned inside the vitreous chamber be connected to an externally positioned functional unit (EPF) via wireless coupling of two coils. The coil of the internal functional unit is in this case arranged in the lens behind the iris.

[0003] In addition to the surgical intervention on the vitreous body for implanting the functional unit (IGF) positioned inside the vitreous chamber, a second surgical intervention is necessary in the anterior eye section for implanting the coil or a second functional unit (AGF) positioned outside the vitreous chamber (especially in the lenticular capsule in place of the intraocular lens (IOL), which needs to be removed before-hand).

[0004] The second functional unit (AGF), which is implanted in the lenticular capsule and is provided, in particular, in the case of various retinal implants, is mechanically connected to the IGF via a microcable and, in currently available versions, cannot be temporarily separated and re-connected. Technical solutions for this are, however, available. This mechanical connection makes the surgical interventions significantly more difficult since, when implanting the AGF in the lenticular capsule envelope, it is also necessary to make an opening in the lenticular capsule wall and to transfer the IGF, with the microcable connection, through this opening into the vitreous chamber. This entails additional risk factors such as: mechanical destabilisation of the lenticular capsule envelope by the additional opening; mechanical stress on the implant components, including the microcable; lengthening of the implantation time; increase in the risk of future pathological tissue changes, which may make the implant function or further surgical interventions (such as e.g. re-implantation) difficult or impossible.

[0005] Positioning the AGF in the anterior eye segment significantly restricts optical access to the retina and to the IGF. This can have a detrimental effect both on the function of the implant system and on sight, as well as on the medical inspectability of the vitreous chamber.

[0006] Externally positioned functional units (EPF) located outside the body are positioned immediately in front of the eye, in the normal field of view of the eye, in place of a spectacle lens or a contact lens, and hence impede any partial sight which may still remain (e.g. in subjects with macular degeneration and remaining extrafoveal vision).

[0007] As the signal processing effort rises, especially in the case of retinal implants, when the number of microcontacts increases, the mass and energy demand of the micro-electronic components rises significantly, so that in this context a limit for intraocularly implantable functional units is rapidly reached and the desired functional quality of the implant is thereby substantially restricted.

[0008] It is therefore an object of the present invention to provide a retinal implant in which the connection between the internal functional unit IGF and at least one external

functional unit (AGF, EPF) does not interrupt the optical path between the lens and the extrafoveal region of the retina, and in which this connection is wireless or can be mechanically separated during implantation.

[0009] This object is achieved by a retinal implant having the features of claim 1. Because the signal path extends through the sclera of the eye, inside the eye socket bounded by the conjunctiva, the optical path from the lens to the retina outside the foveal region remains free. The separability of the signal path permits separate implantability of the component implanted inside the eye and the component implanted outside the eye in the eye socket.

[0010] Advantageous embodiments are given in the dependent claims.

[0011] Two exemplary embodiments of the present invention will be described below with reference to the drawing, in which:

[0012] **FIG. 1** shows an implant with a wireless inductive connection between the internal functional unit and a second functional unit implanted outside the eye;

[0013] **FIG. 2** shows a similar implant to **FIG. 1**, with a separable plug connection between the internal functional unit and a second functional unit implanted outside the eye; and

[0014] **FIG. 3** shows a perspective representation of the implant according to **FIG. 1**

[0015] **FIG. 1** represents a retinal implant or patients having a degenerative disease of the retina **1**, in which the functional unit (EPF) **2** present outside the body is positioned in the head region (e.g. on the side of a spectacle frame with normal spectacle function), in such a way that the optical beam path between viewed objects and the retina **1** is impaired neither by functional units directly in front of the eye nor by functional units in the anterior eye segment, including the intraocular lens (IOL) **3**, and in such a way that, in particular, patients can thereby use their residual vision which may still remain (e.g. in the extrafoveal field of view in the case of macular degeneration), in addition to the implant function.

[0016] In a retinal implant according to the invention, the functional unit IGF **4** positioned inside the vitreous chamber is designed as a microcontact foil having associated microelectronics, a microcable **5** and at least one coil **6**, and is fastened close to the retina in a suitable way. Via this coil **6** as part of the IGF **4** and at least one corresponding coil **7** as part of the AGF **8** inside the eye socket, a communication connection is made inductively through the sclera **9**. Since the signal path through the sclera **9** of the eye extends inside the eye socket bounded by the conjunctiva **19**, the optical path from the lens to the retina outside the foveal region remains free. The separability of the signal path permits separate implantability of the component implanted inside the eye and the component implanted outside the eye in the eye socket.

[0017] **FIG. 2** illustrates another embodiment of a retinal implant according to the invention. In this case, the trans-scleral connection between the IGF **4** and the AGF **8** is made galvanically via a microcable **10**, the microcable being mechanically separated at a plug connection **11** during implantation, and the connection being made subsequently.



Such a microcable connection **10** which can be made subsequently between the IGF **4**, which e.g. performs only retinal stimulation, and an AGF **8** which undertakes decoder and/or demultiplexing functions, and which is implanted but located outside the eye, may preferably be configured in such a way that, according to the ophthalmological state of the art, a suitable transscleral cannula **12** is permanently implanted, the microcable **10** is fed through it, and the passage is sealed afterwards. The subsequent microcable connection **10** may furthermore be designed in such a way that the two ends to be galvanically connected (corresponding to a male or female plug connector) carry an equal number of complementarily shaped metal contacts (e.g. as pins at one cable end and as sockets at the other cable end) which, during the separate implantation of the IGF **4** and the AGF **8**, are covered with an insulating thin plastic film for protection against the effect of fluids.

[0018] In a preferred embodiment, the microcable connection is established in that the pin part **11** and the socket part **11'** are positioned flat facing one another while aligning the rows of pins and corresponding sockets, and in that the pin part and the socket part can thereupon be pressed cleanly against one another in such a way that, on the one hand, the insulating film is pierced and, on the other hand, securely insulated galvanic connections of the corresponding microcable lines **10** are made even under wet environment constraints

[0019] In a preferred embodiment, this microcable connection can subsequently be re-separated by a suitable separating tool.

[0020] This separable microcable connection, consisting of the pin part **11** and the socket part **11'**, can preferably be produced both outside the eyeball in the eye socket (see FIG. 2) and inside the vitreous chamber (no image).

[0021] In likewise advantageous embodiments, the wireless transscleral communication is produced optoelectronically or by ultrasonic transmitter and receiver pairs on both sides of a circumscribed scleral zone.

[0022] In another embodiment, a cannula **12** is arranged in the wall of the sclera **9** according to the ophthalmological state of the art, and is shut off by a permeable film in the manner of a closed window.

[0023] In another embodiment, the AGF **8** is fastened sclerally to the outer wall of the bulb according to the ophthalmological state of the art (adhesive bonding, pinning or suturing) and has, in addition to a microcable **5** and at least one primary coil **7** fastened sclerally facing the respective corresponding coil **6** in the vitreous chamber, a further microcable **15** for connection to the functional unit (EPF) **2** located outside the body.

[0024] In a preferred embodiment, the connection between the AGF **8** in the eye socket and the external EPF **2** is made inductively via a coil pair **16, 17** and associated transmission and reception electronics **18**, this coil pair **16, 17** being separated by a skin region in the head area (e.g. on the

forehead) and the microcable **15** from the AGF **8** to the secondary coil **16** and the reception electronics **18** of this preferably transcutaneous inductive connection being laid under the skin according to the surgical state of the art.

[0025] In another possible version, the connection between the AGF **8** in the eye socket and the external EPF **2** is made via a suitable catheter structure and/or cable structure (not shown).

[0026] In an advantageous embodiment, in order to set up a function outside the normal implant operation, optical and/or optoelectronic communication is produced between a functional unit located outside the body and the IGF **4** in the vitreous chamber.

[0027] The external functional unit **2**, which may comprise an encoder as well as camera means, may also, in one embodiment according to the invention, be worn by the patient in a manner other than with the conventional spectacle-type arrangement. For instance, the requisite components may also be arranged in a cap or a headband, which make it possible to avoid wearing spectacles which may be uncomfortably heavy. This furthermore permits the use of larger components, which are suitable for processing a larger number of optical channels or pixels.

1. Retinal implant having at least one functional unit **4** positioned internally inside an eye and at least one functional unit **2** positioned externally outside the eye, which are connected to one another via a signal path (**5, 6, 7, 15, 16, 17; 10, 11, 12, 15, 16, 17**) in a manner designed for signal or data transmission, characterised in that the transscleral signal-path segment between the functional units (**4, 8**) can be separated, and in that the signal path between the functional units (**2, 4**) does not incorporate the anterior eye section, including the cornea and intraocular lens.

2. Implant according to claim 1, characterised in that the signal path comprises a wireless inductive connection (**6, 7**) which has a respective transmission and reception element inside (**6**) and outside (**7**) the eye, which are arranged facing one another, the sclera (**9**) lying between the transmission and reception elements (**6, 7**).

3. Implant according to claim 1, characterised in that the signal path comprises a galvanic connection (**10, 11, 11'**) which passes through the sclera.

4. Implant according to claim 3, characterised in that the galvanic connection (**10, 11, 11'**) can be connected after implantation, and preferably disconnected, at mutually complementary contact elements (**11, 11'**).

5. Implant according to one of the preceding claims, characterised in that the sclera (**9**) is penetrated by a cannula (**12**) which is used for feeding an electrical cable (**10**) through.

6. Implant according to one of the preceding claims, characterised in that a functional unit (**8**) implanted outside the eye, which is designed to carry out signal processing functions, is provided.

\* \* \* \* \*