



US 20020123163A1

(19) **United States**

(12) **Patent Application Publication**
Fujii

(10) **Pub. No.: US 2002/0123163 A1**

(43) **Pub. Date: Sep. 5, 2002**

(54) **EDGE-EMITTING LIGHT-EMITTING SEMICONDUCTOR DEVICE AND METHOD OF MANUFACTURE THEREOF**

Publication Classification

(51) **Int. Cl.⁷ H01L 21/00**

(52) **U.S. Cl. 438/26**

(76) **Inventor: Takehiro Fujii, Kyoto (JP)**

Correspondence Address:
HOFFMANN & BARON, LLP
6900 JERICHO TURNPIKE
SYOSSET, NY 11791 (US)

(21) **Appl. No.: 10/019,508**

(22) **PCT Filed: Apr. 23, 2001**

(86) **PCT No.: PCT/JP01/03488**

(30) **Foreign Application Priority Data**

Apr. 24, 2000 (JP) 2000-122255
May 8, 2000 (JP) 2000-134159
May 24, 2000 (JP) 2000-152249

(57) **ABSTRACT**

A side-emission type semiconductor light-emitting device **10** includes a substrate **12**, and the substrate **12** is provided with a case **14** formed of a resin having opacity and reflectivity. The substrate **12** is formed, on its surface, with electrodes **18a** and **18b** onto which an LED chip **20** is bonded. A transparent or translucent resin **16** is charged between the substrate **12** and the case **14** whereby the LED chip **20** is molded. A light-emitting surface of the side-emission type semiconductor light-emitting device **10** includes surfaces **16a**, **16b** and a surface opposite to the surface **16b** which are formed of the transparent or translucent resin **16**. Furthermore, the light-emitting surface is formed by a roughened surface. Due to this, a light outputted from the LED chip and a light reflected from the case **14** is scattered by the light-emitting surface.

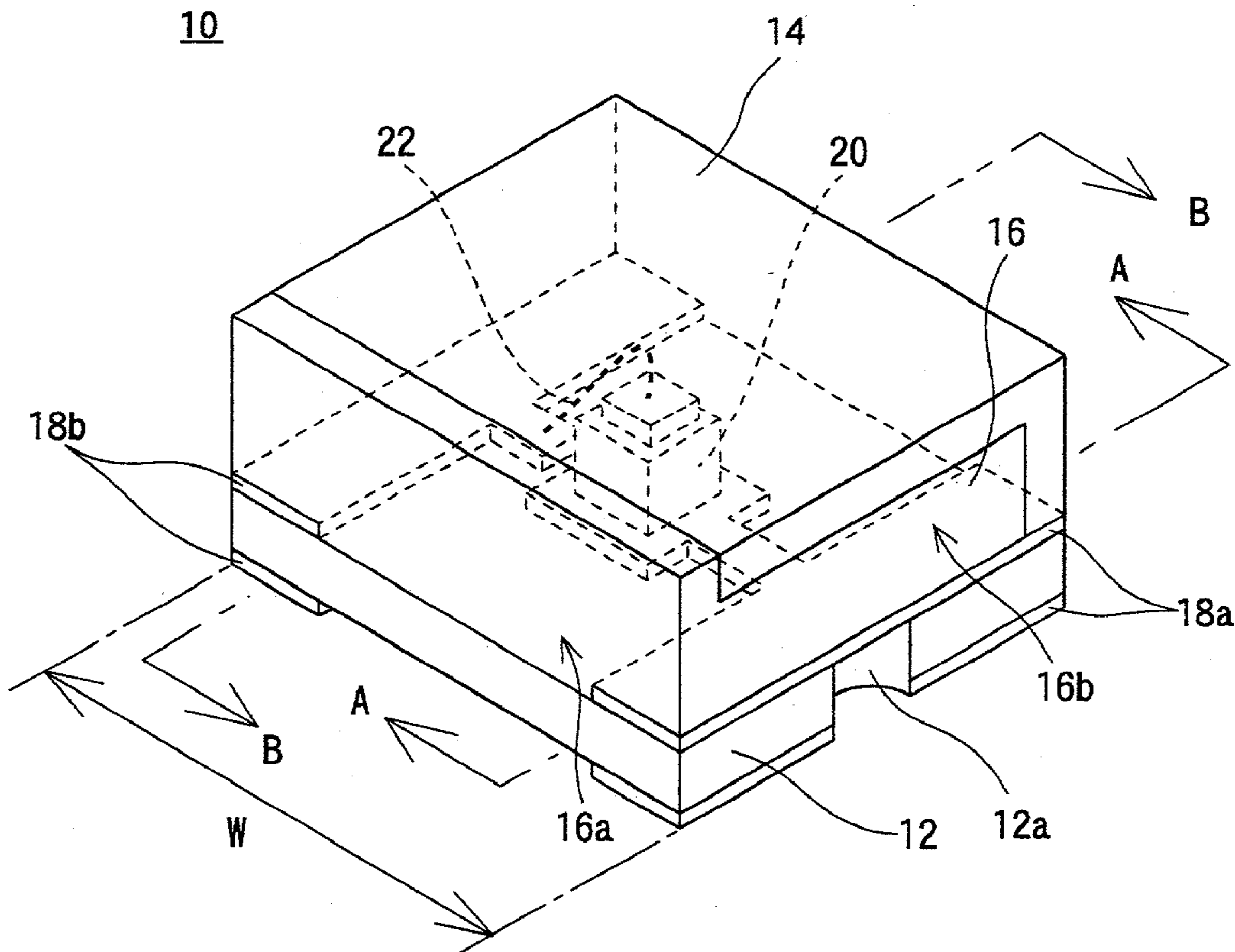

FIG. 1

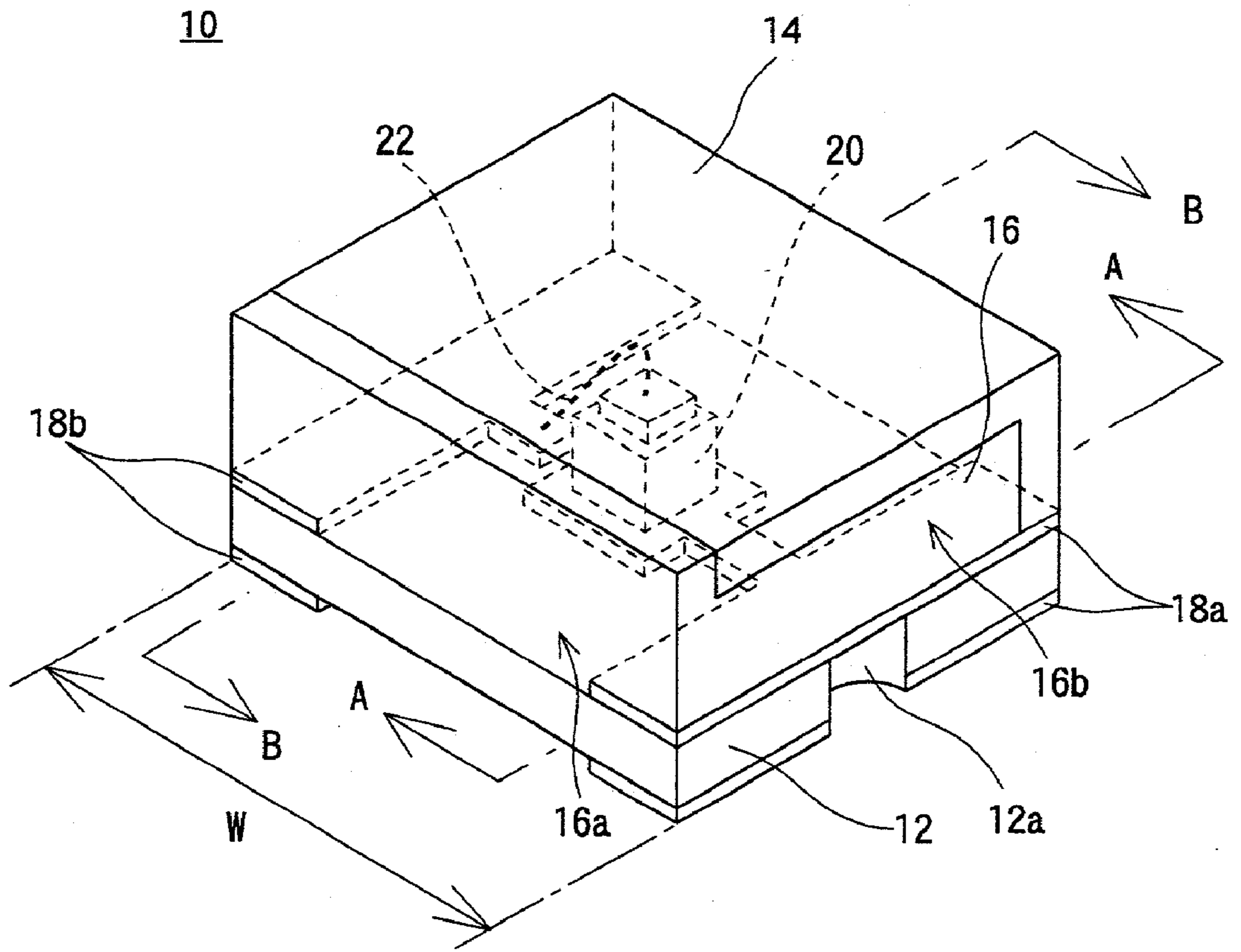

FIG. 2(A)

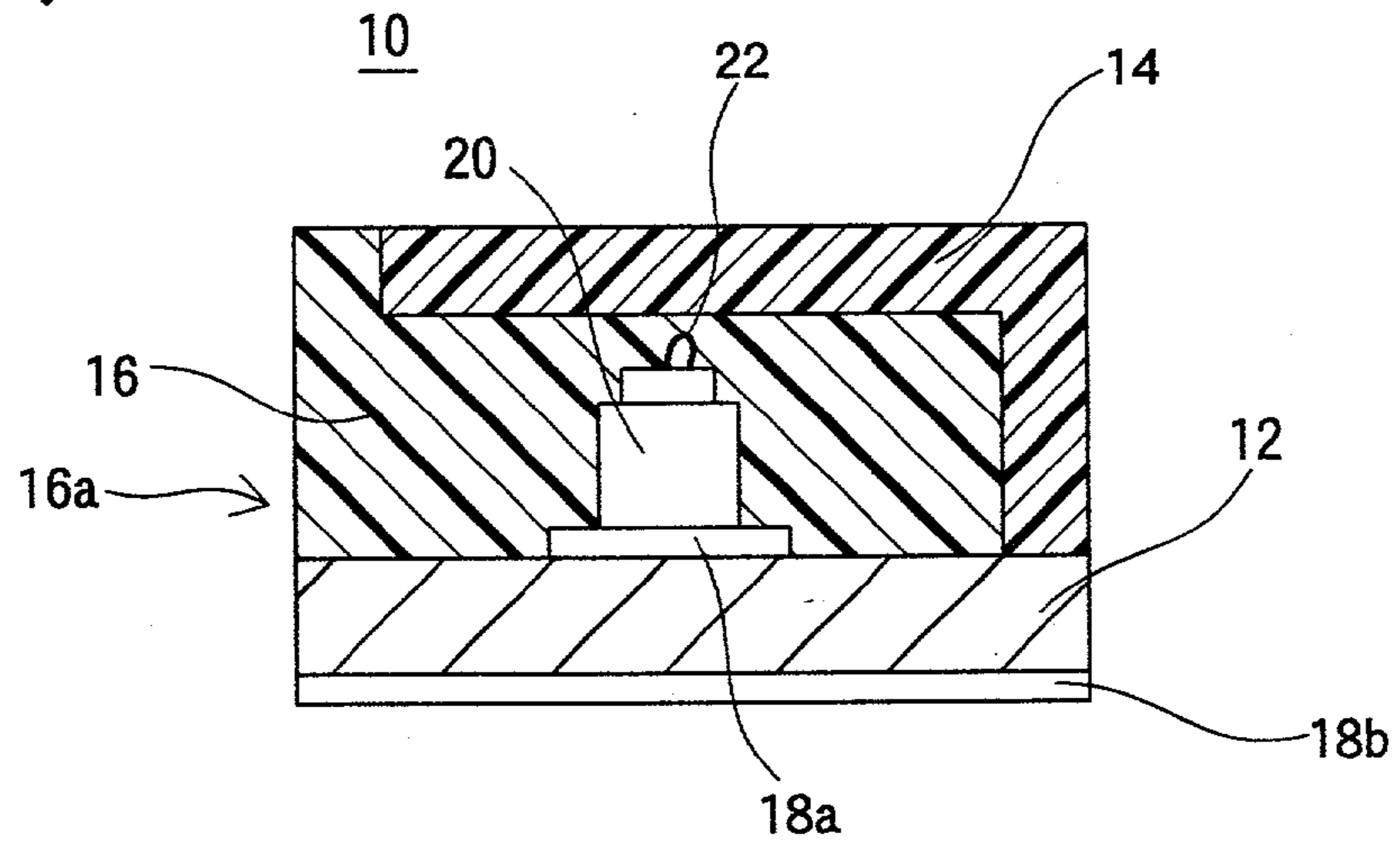

FIG. 2(B)

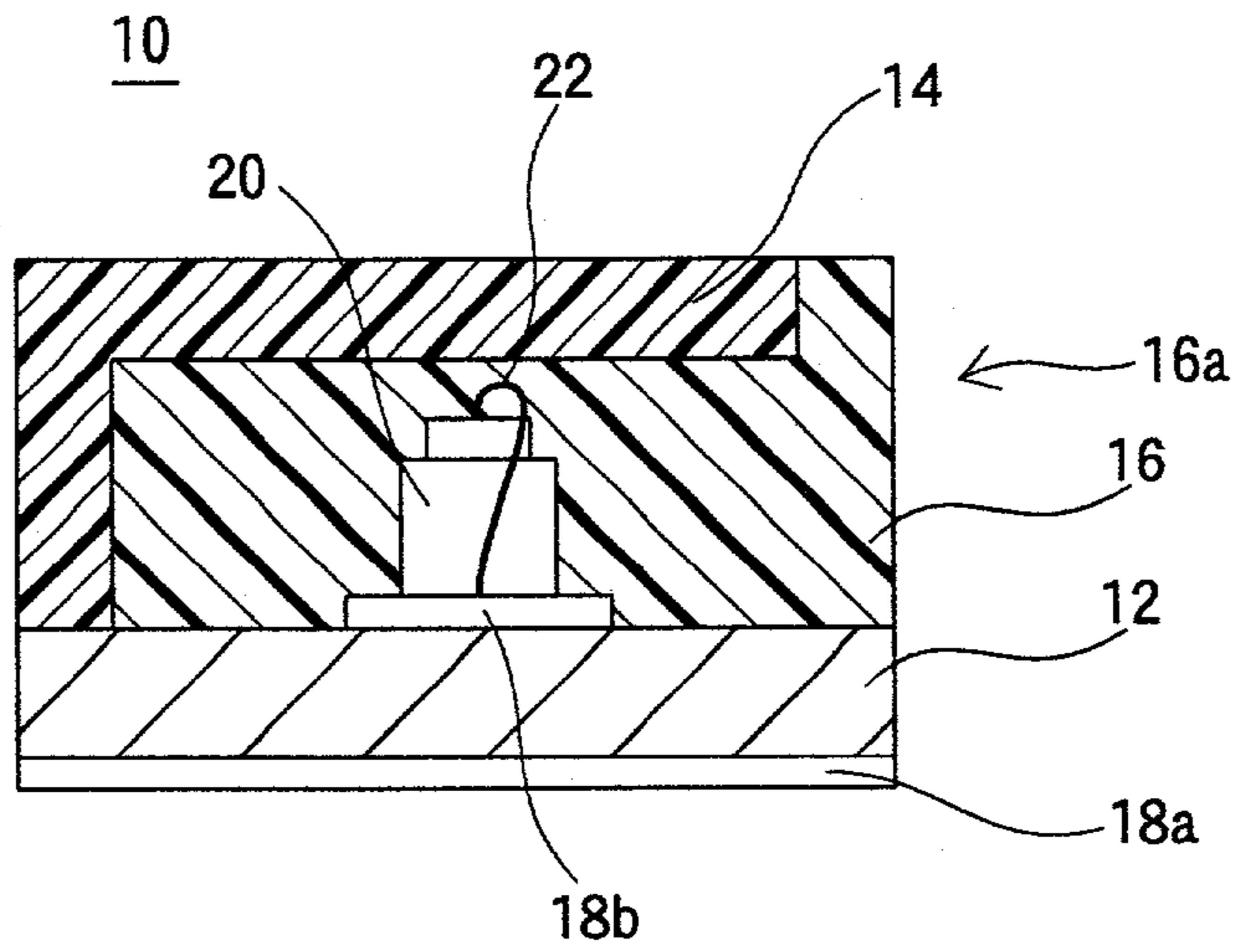

FIG. 3(A)

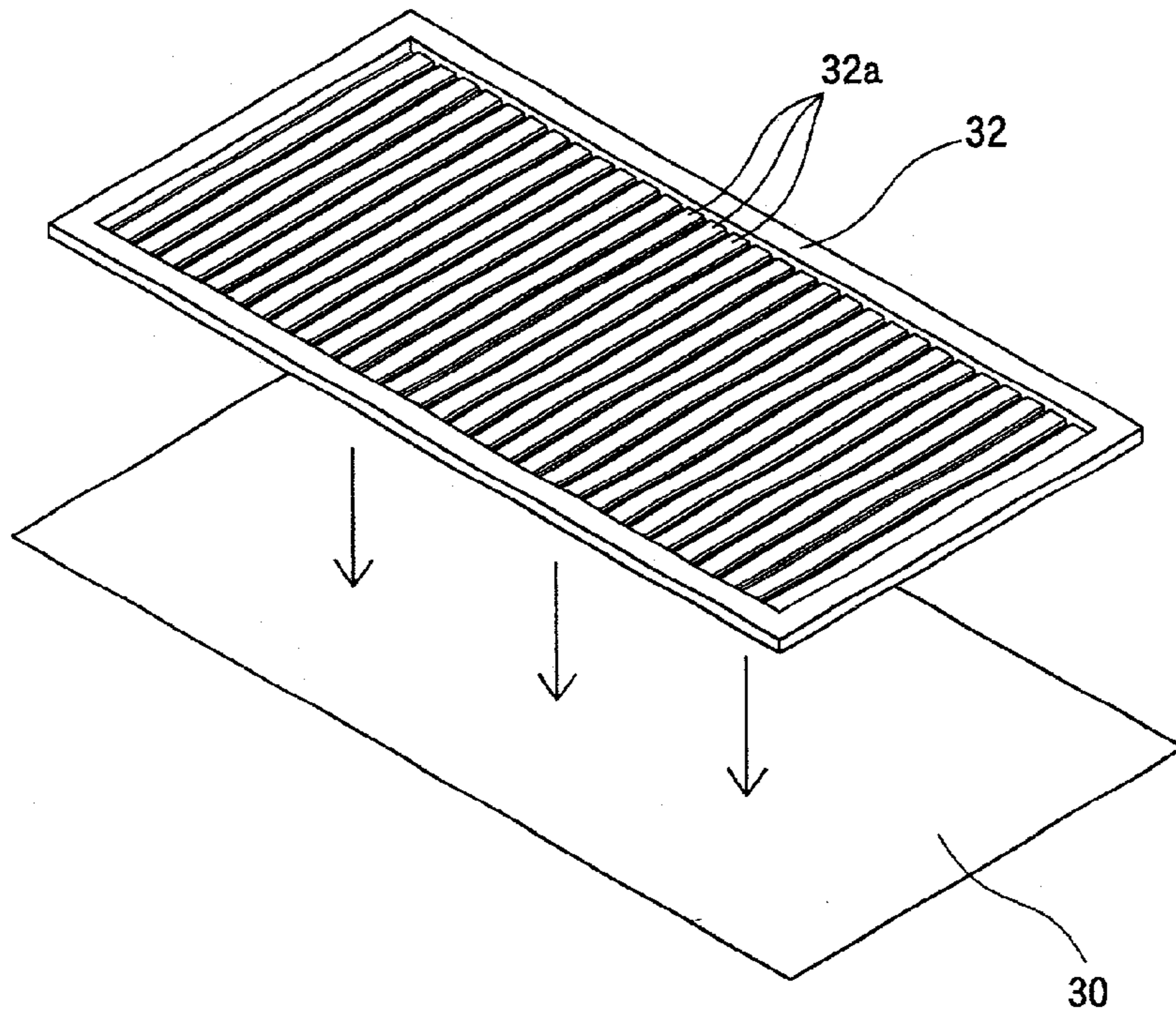

FIG. 3(B)

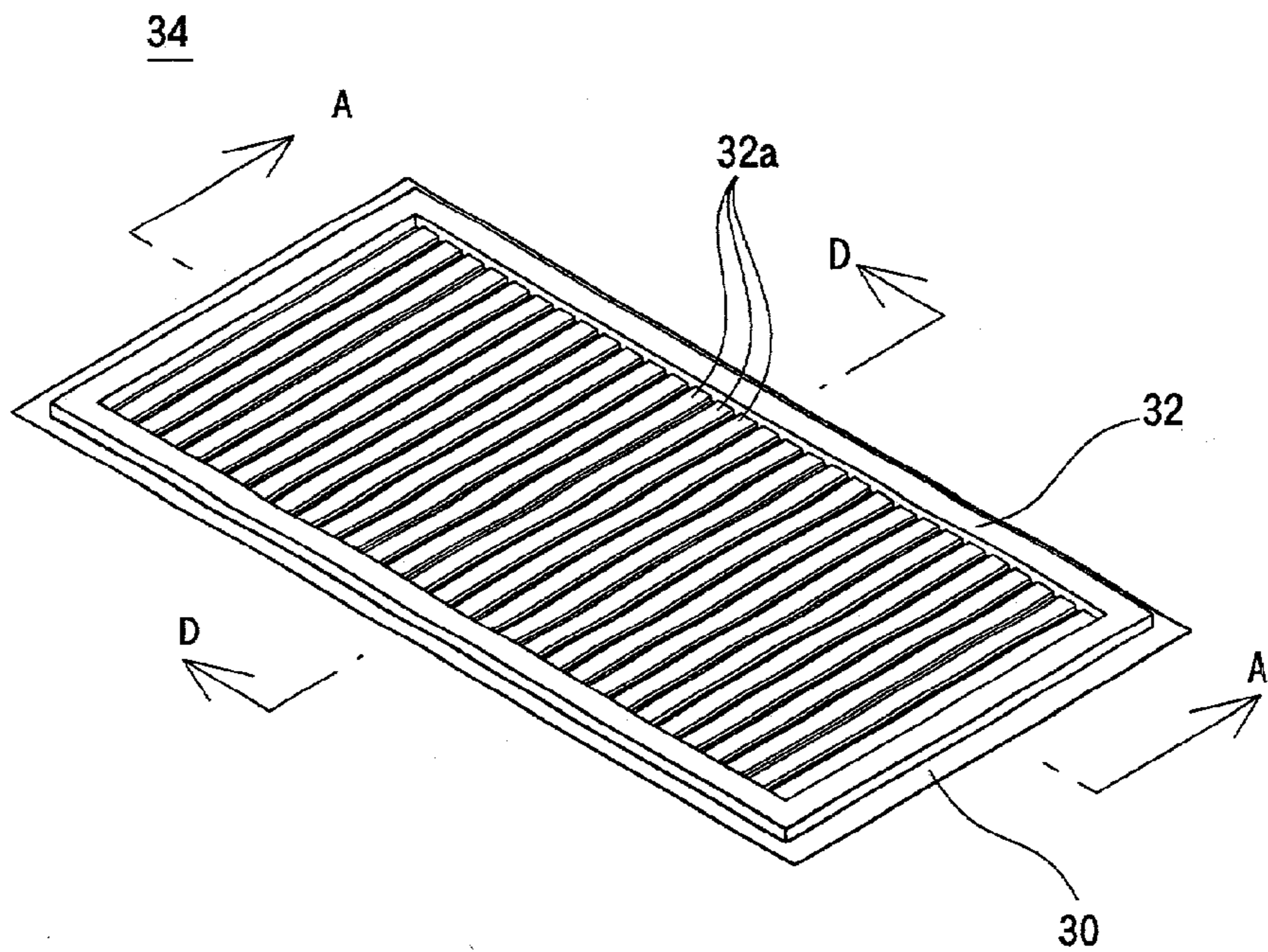

FIG. 4(A)

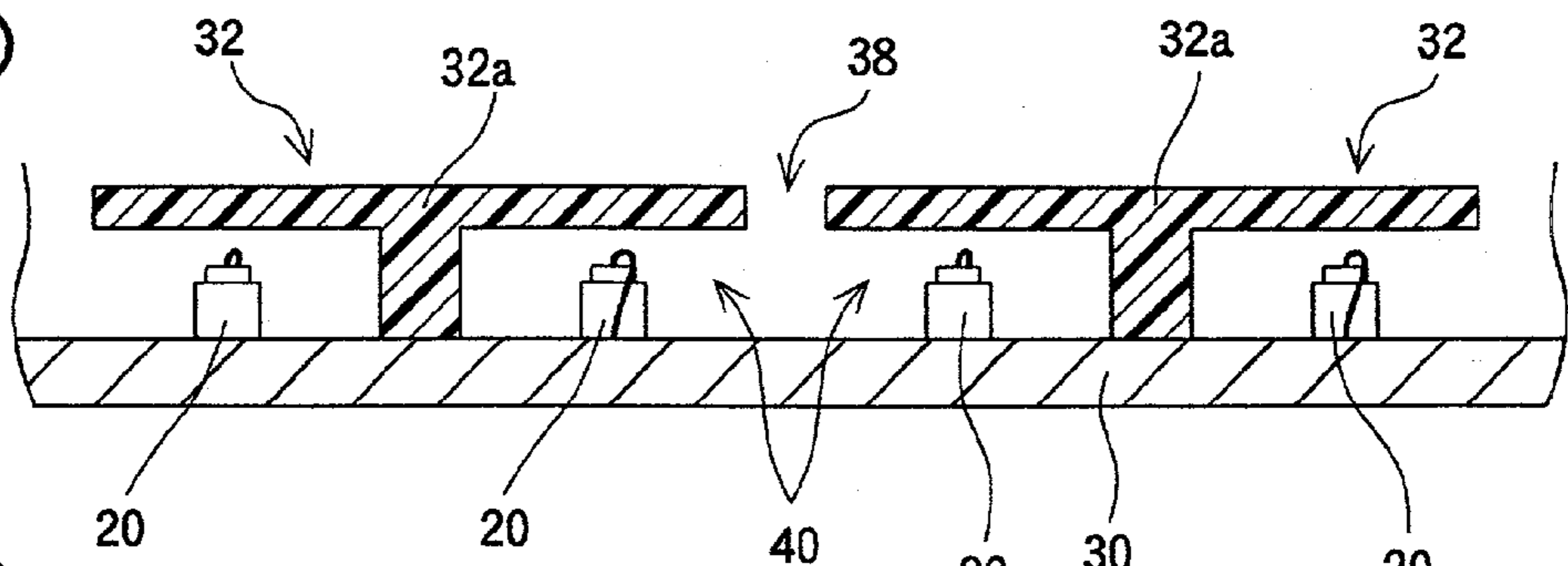

FIG. 4(B)

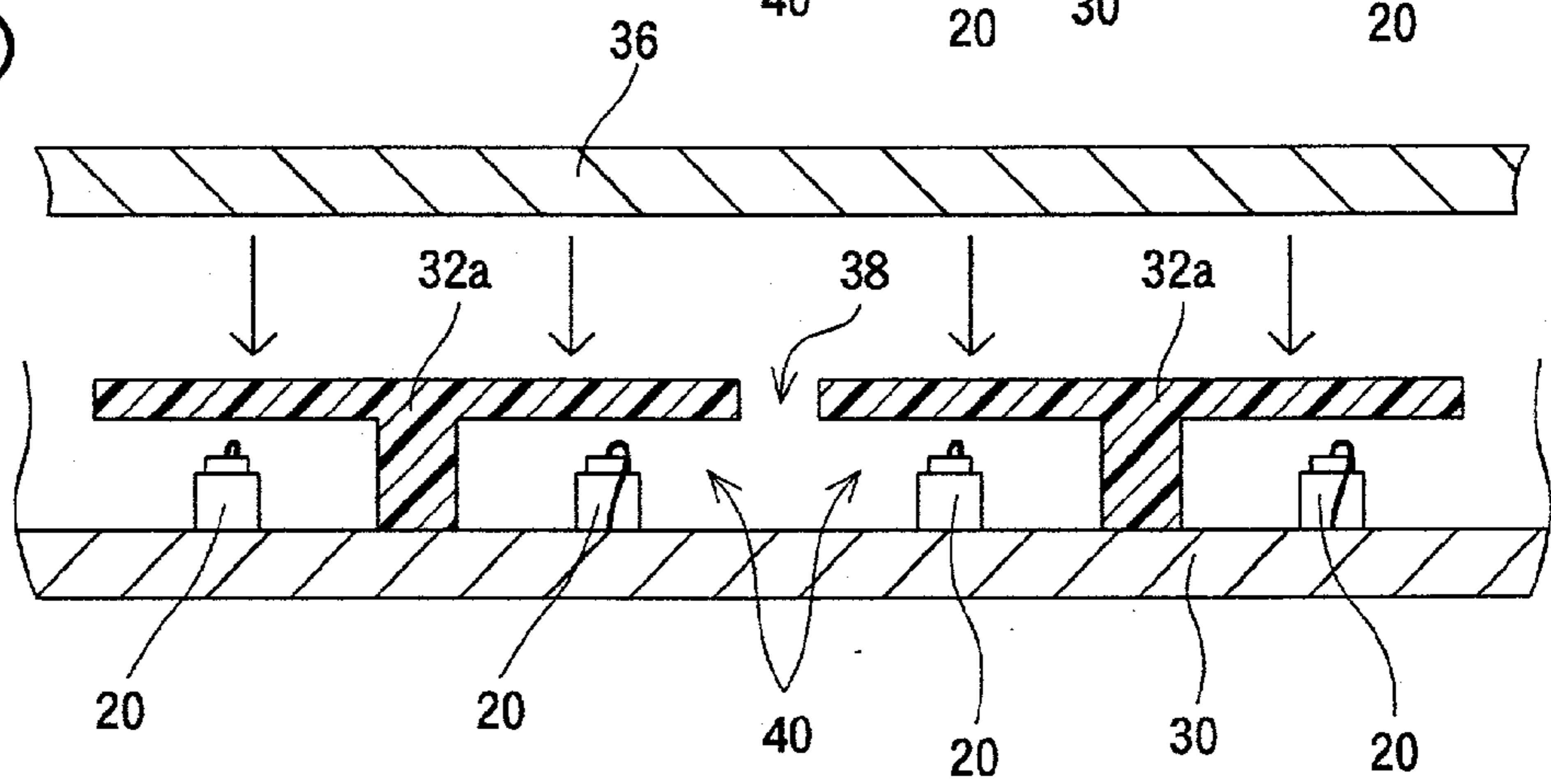

FIG. 4(C)

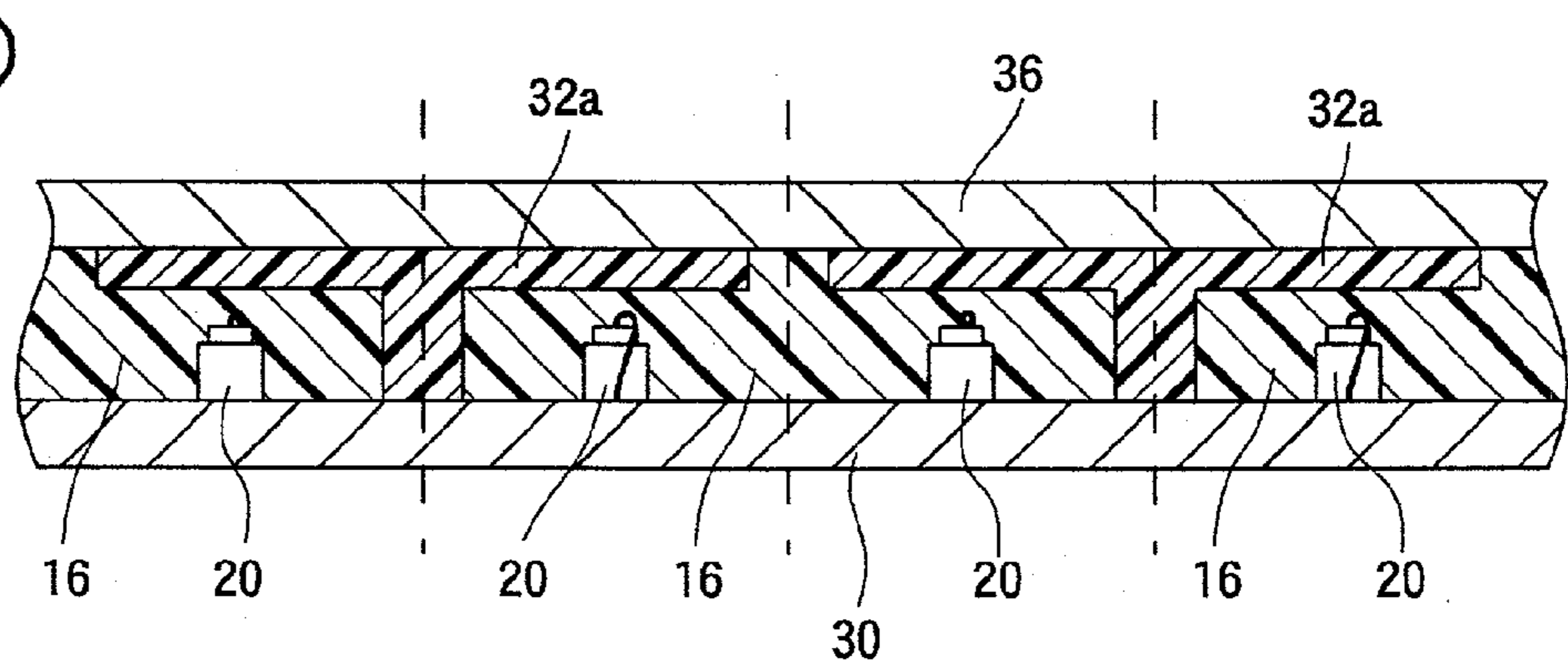

FIG. 4(D)

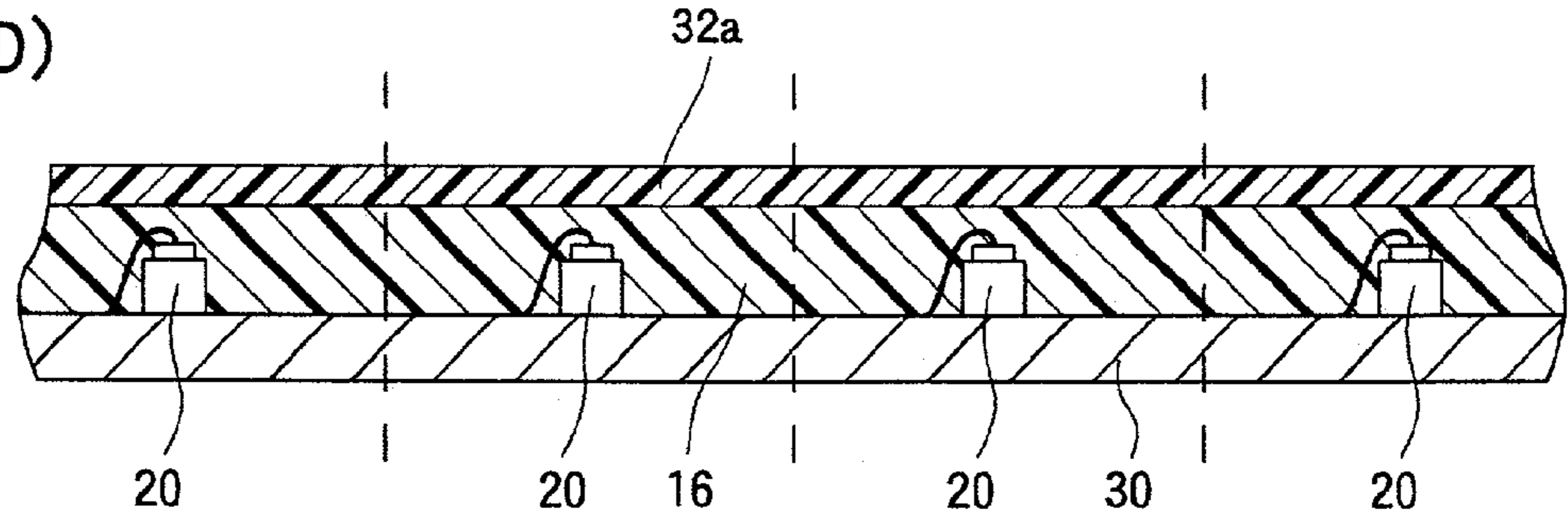

FIG. 5

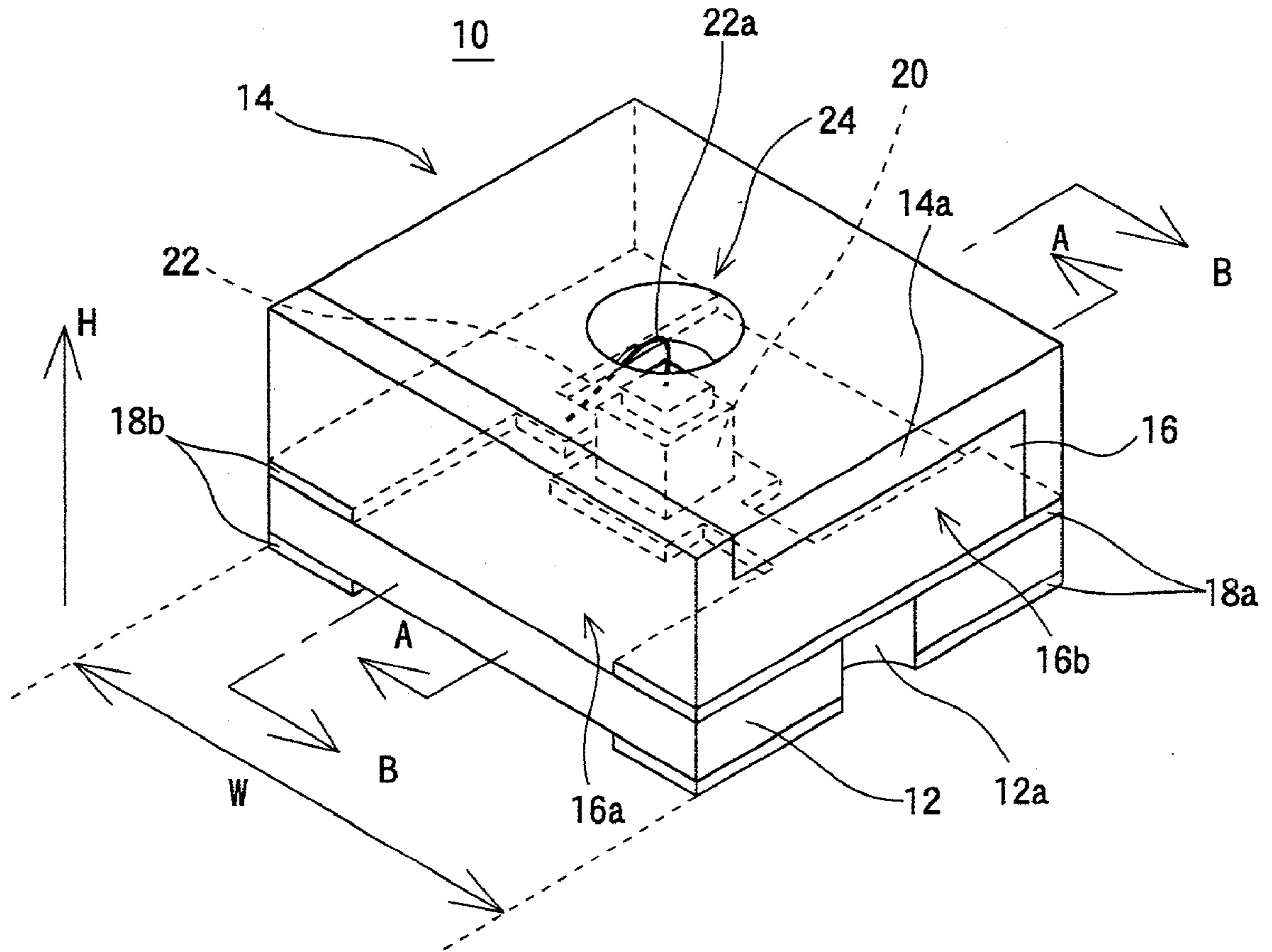

FIG. 6(A)

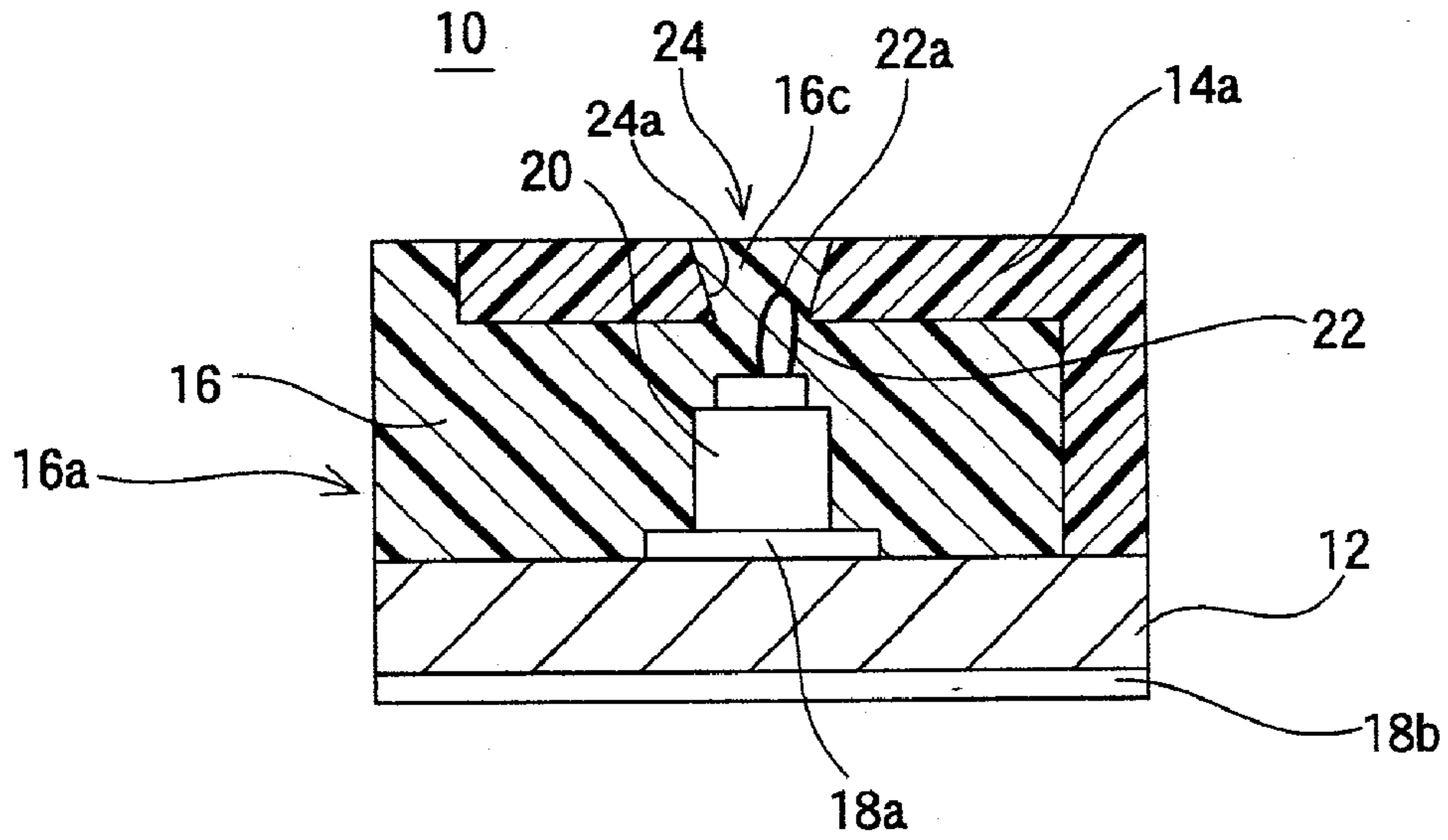

FIG. 6(B)

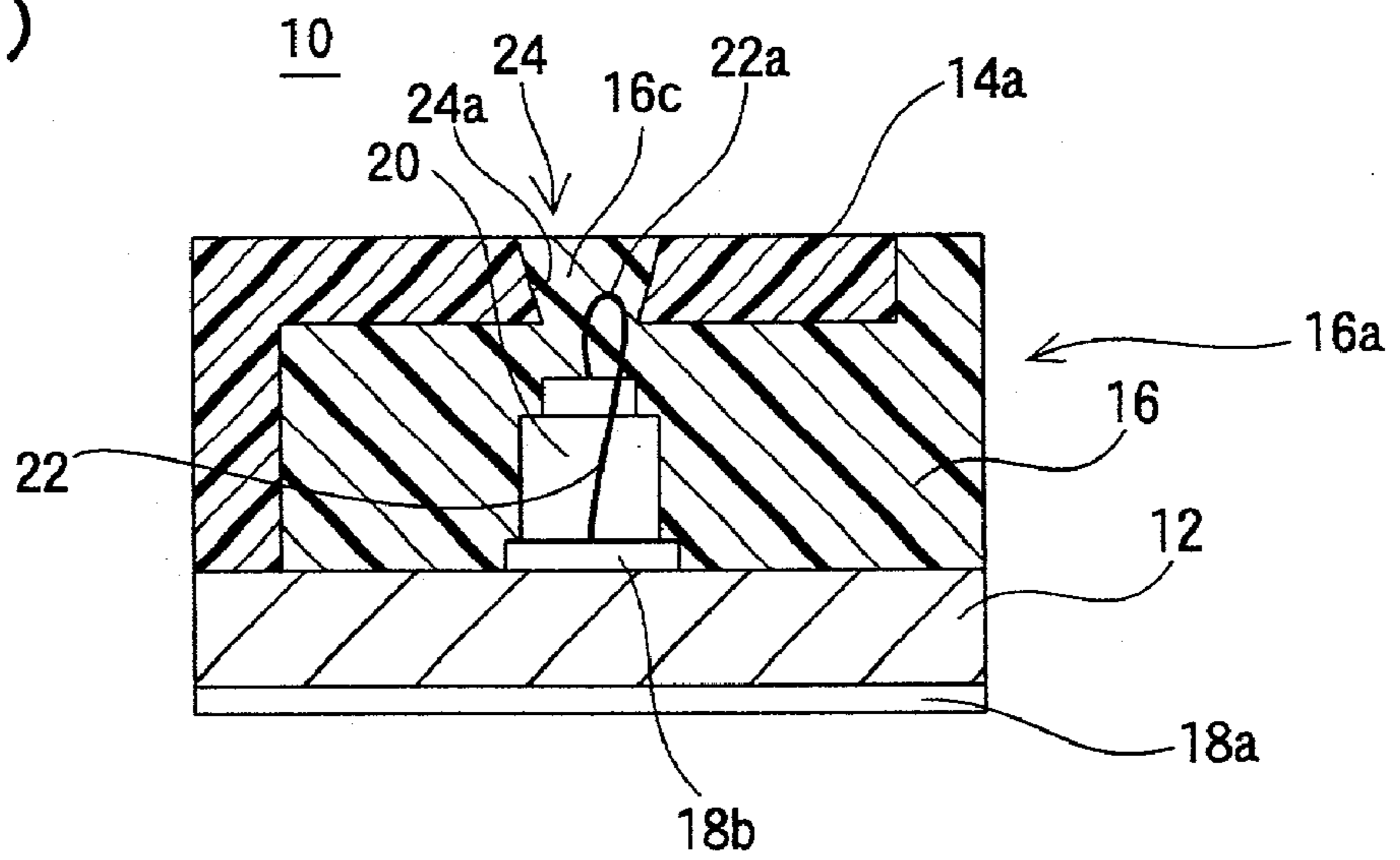

FIG. 7(A)

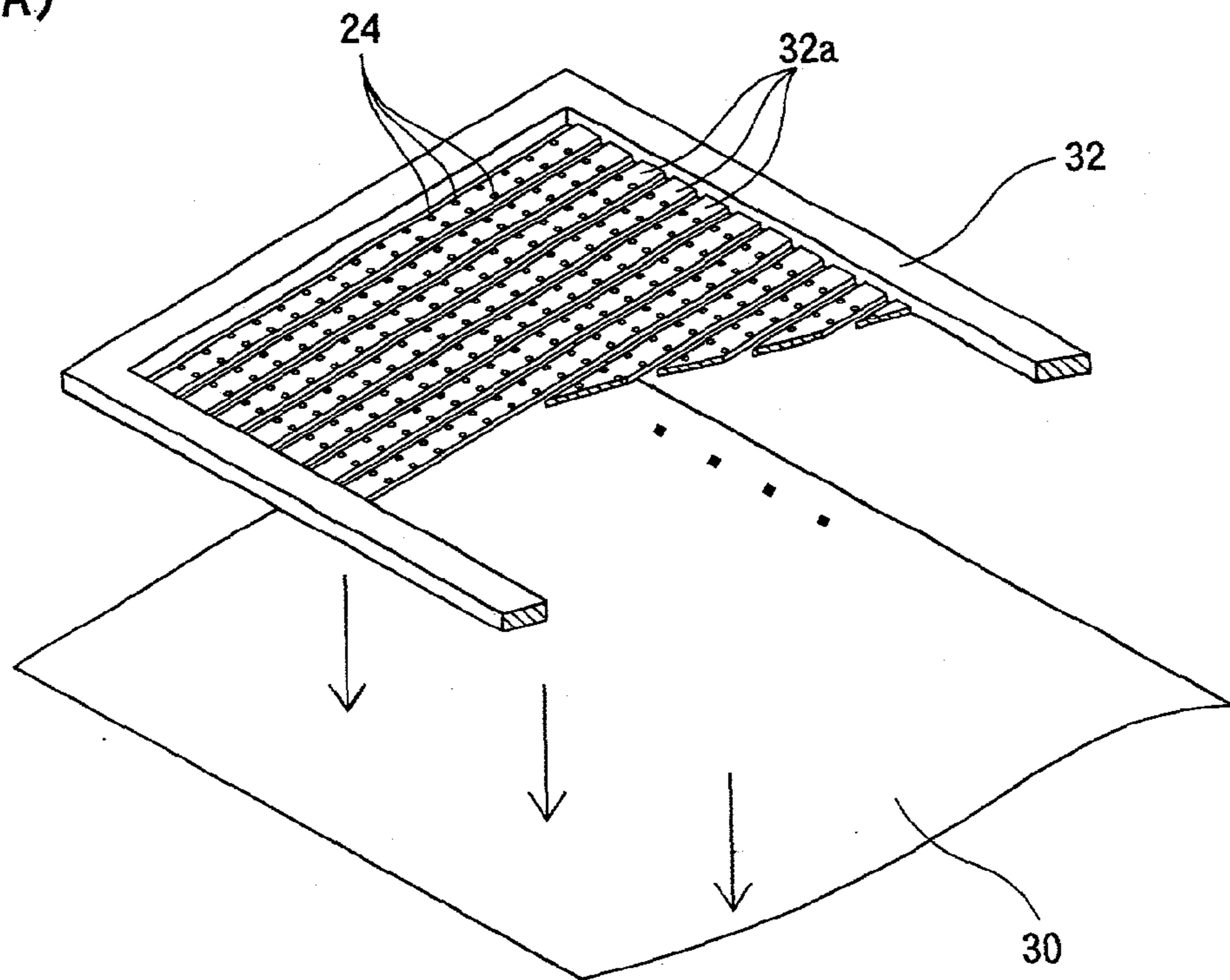

FIG. 7(B)

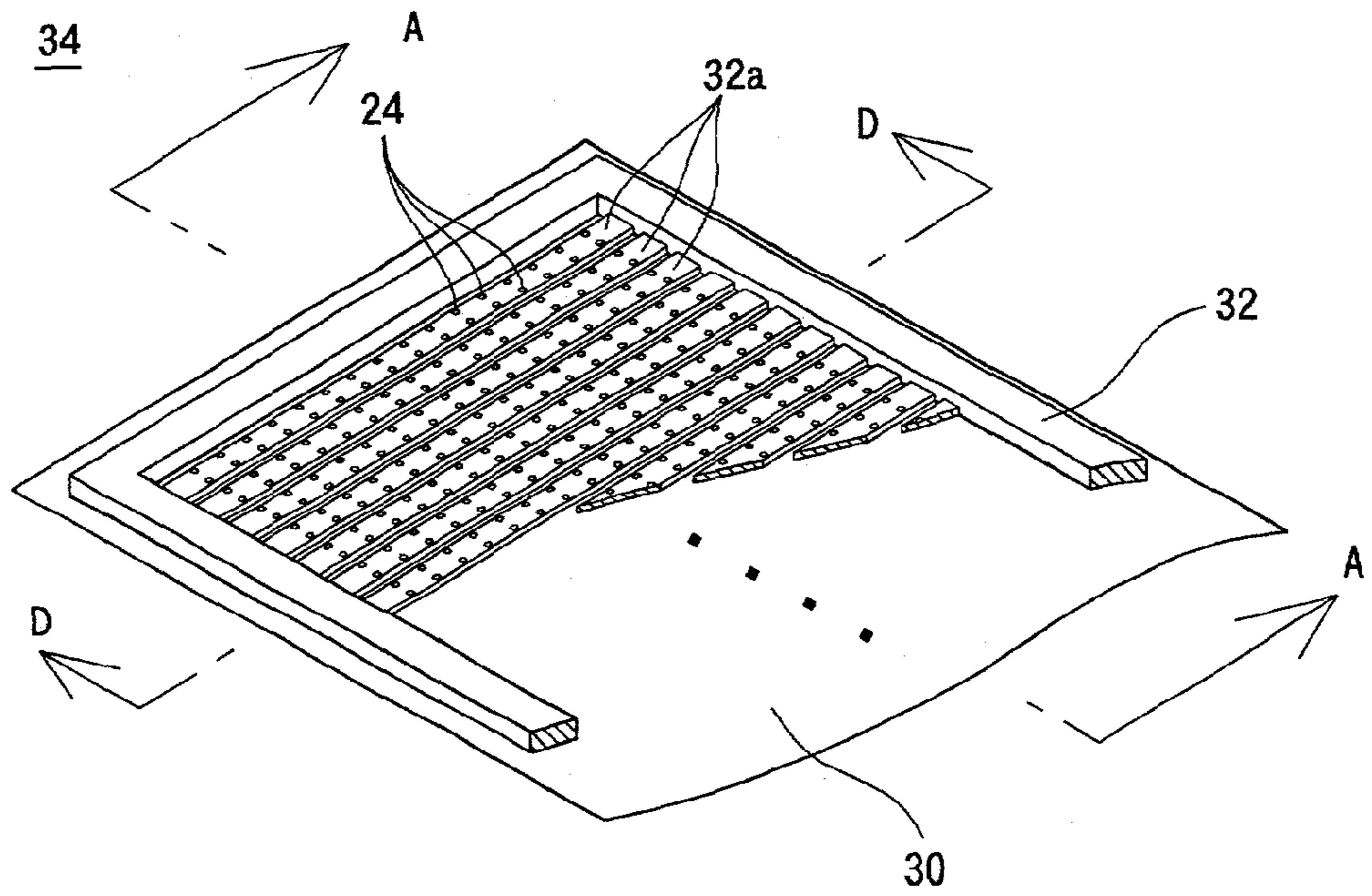

FIG. 8(A)

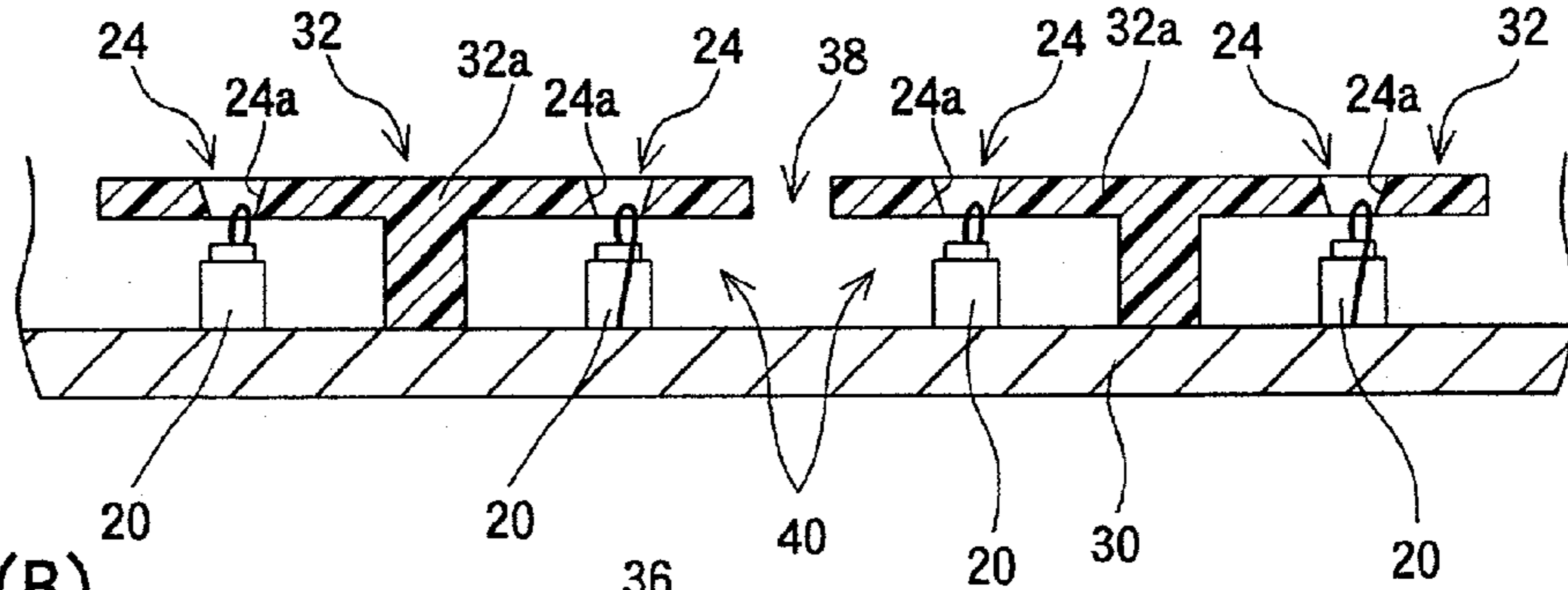

FIG. 8(B)

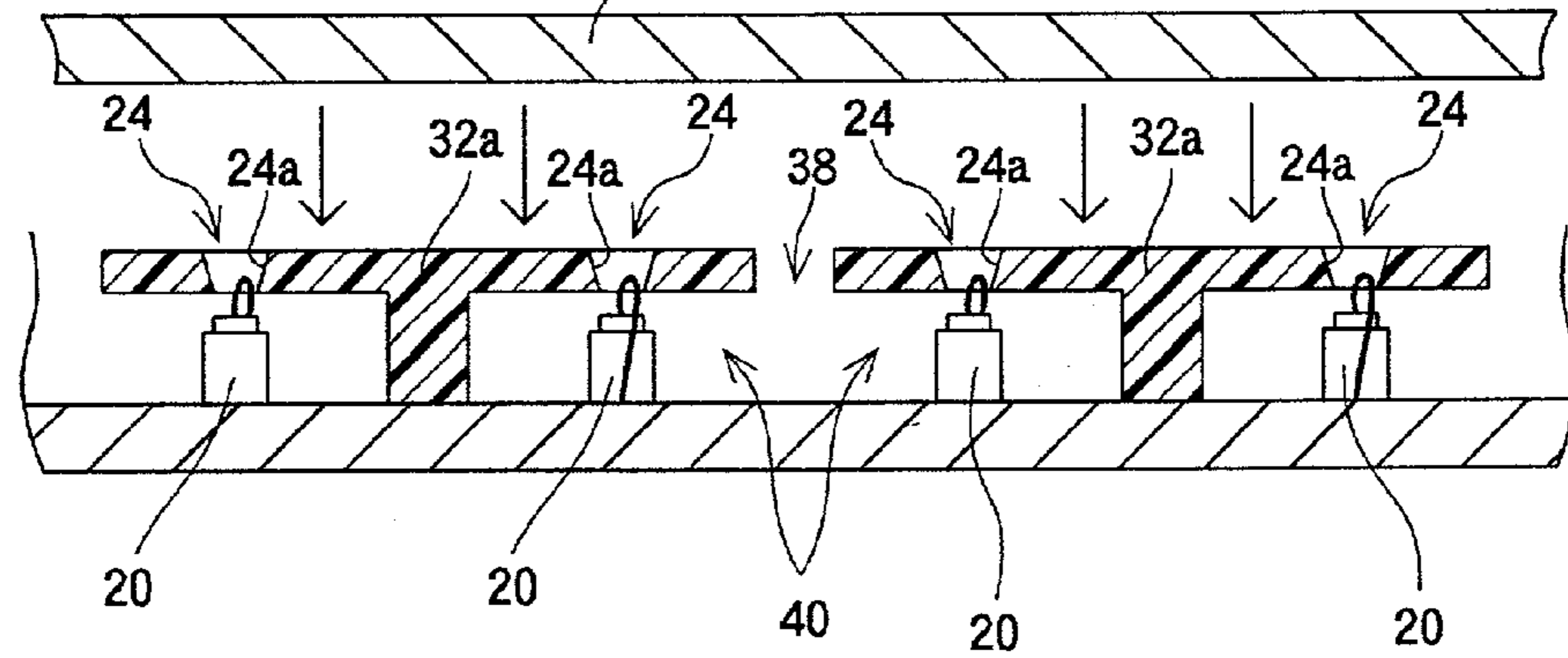

FIG. 8(C)

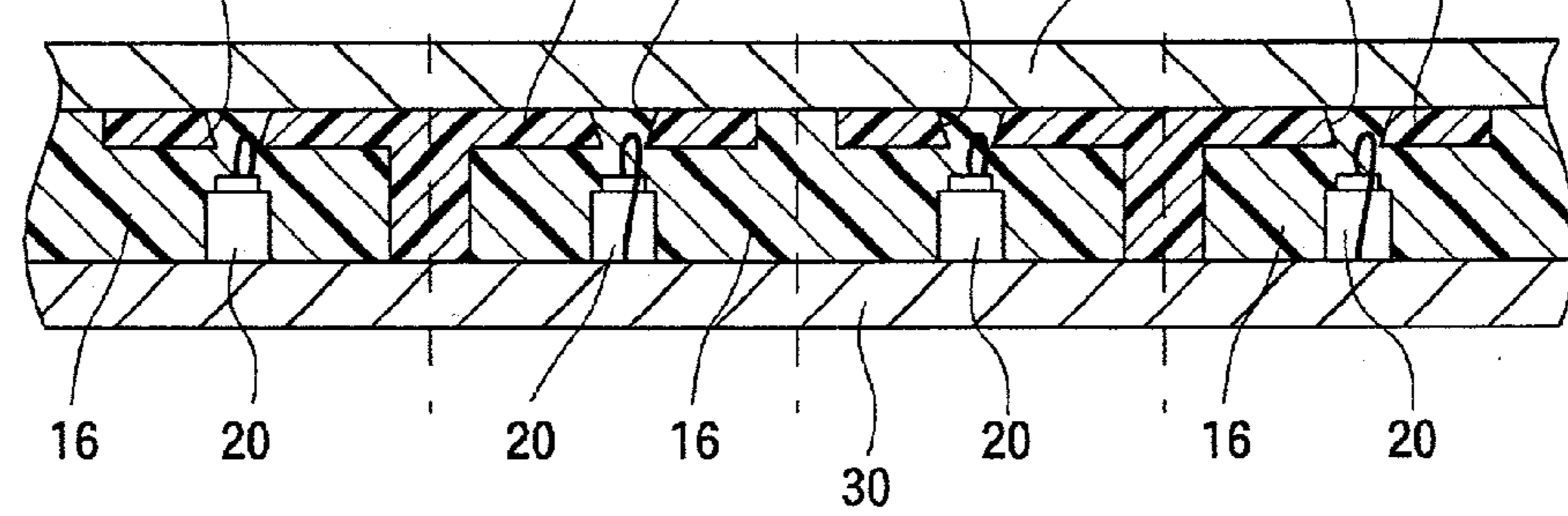

FIG. 8(D)

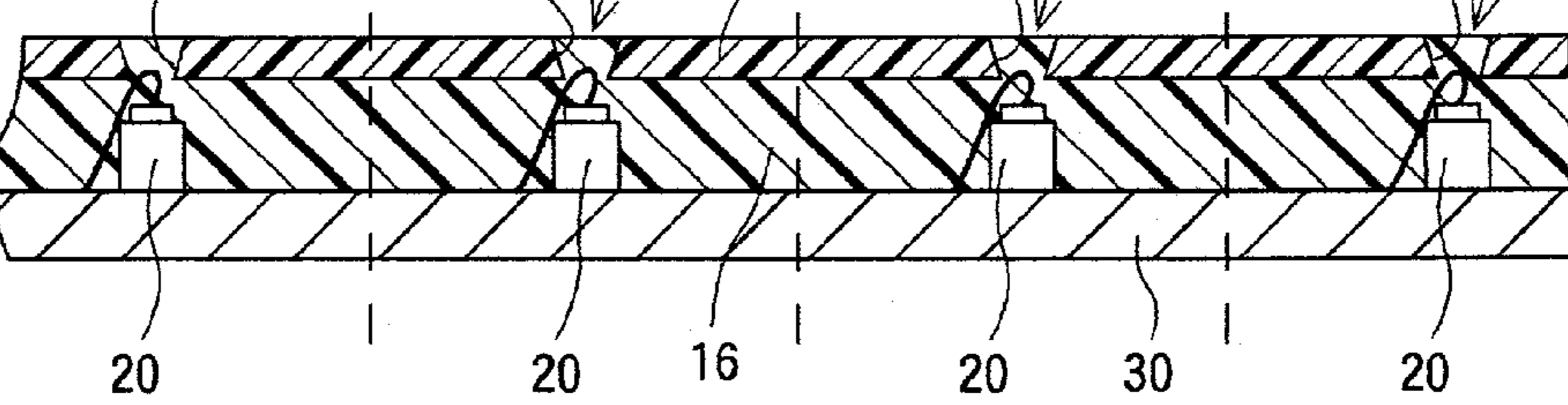

FIG. 9

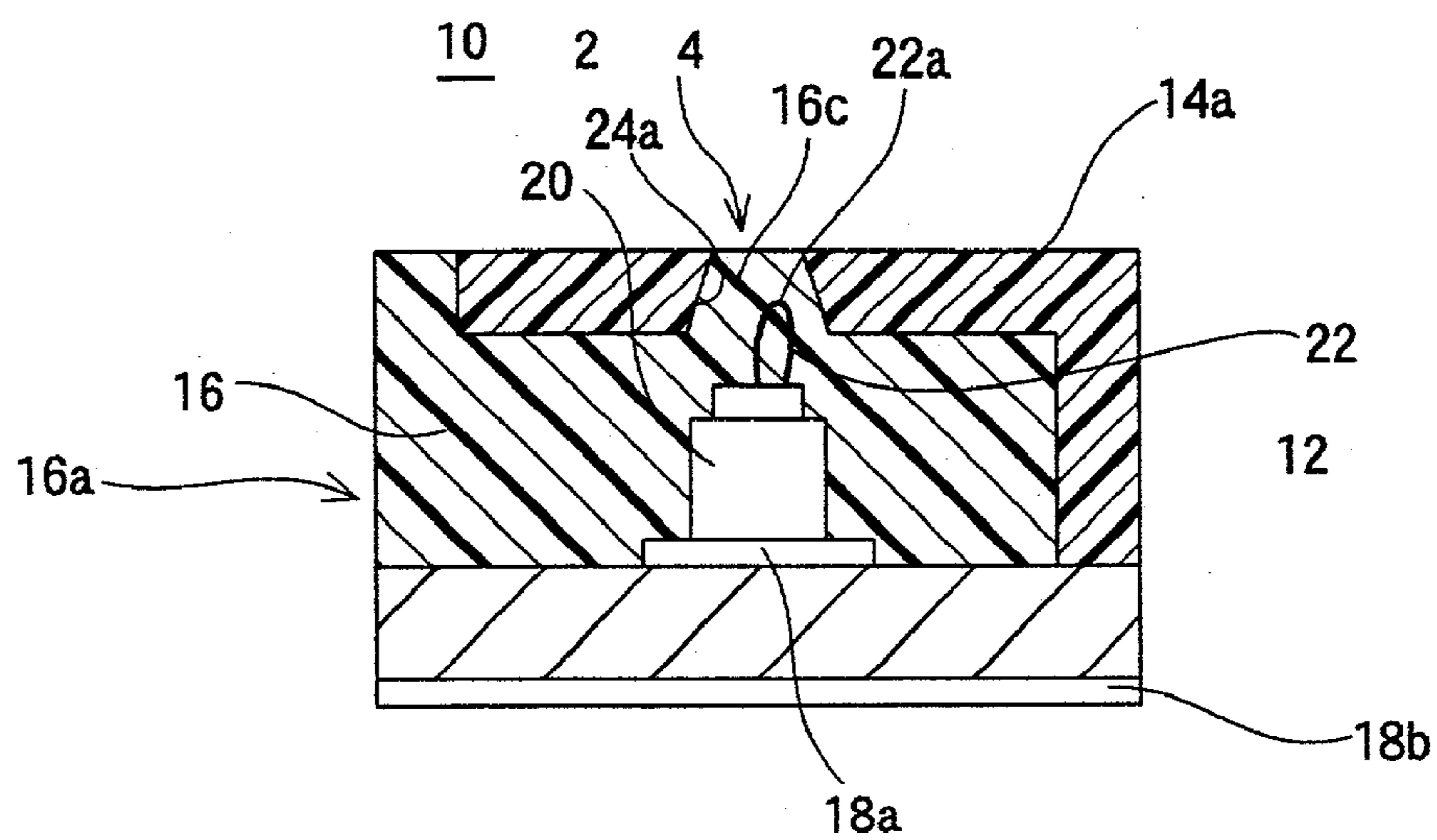

FIG. 10

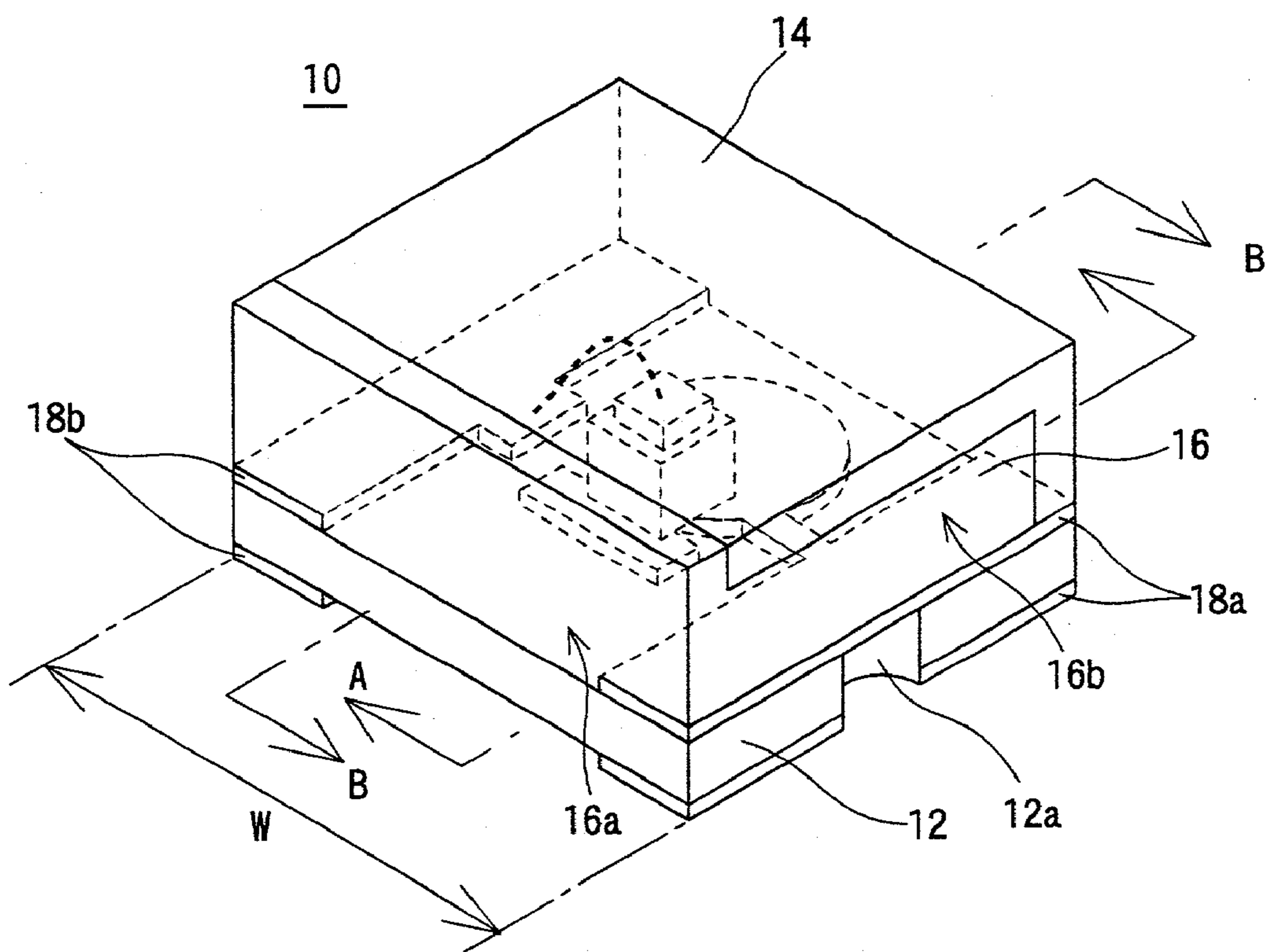

FIG. 11(A)

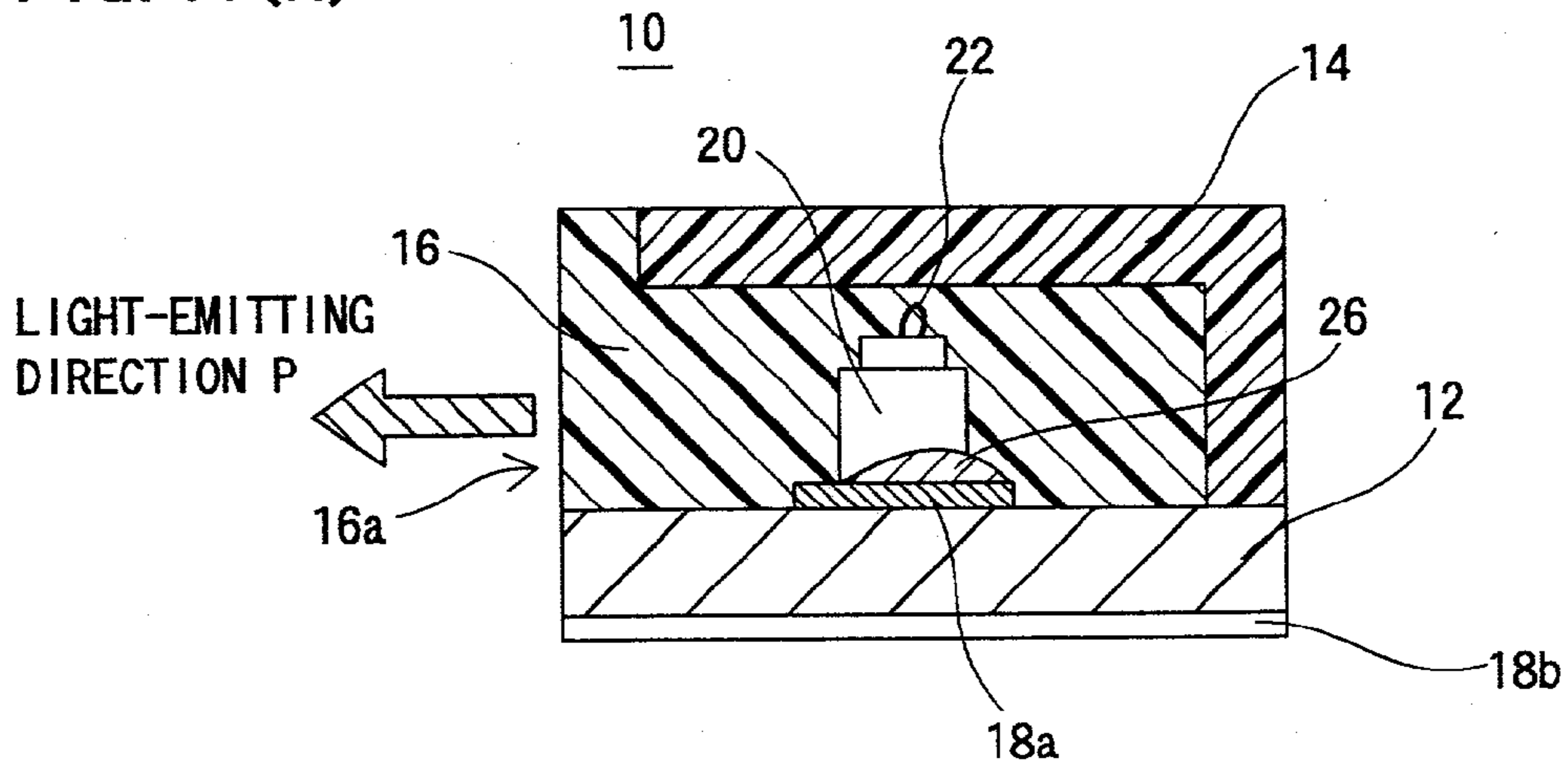

FIG. 11(B)

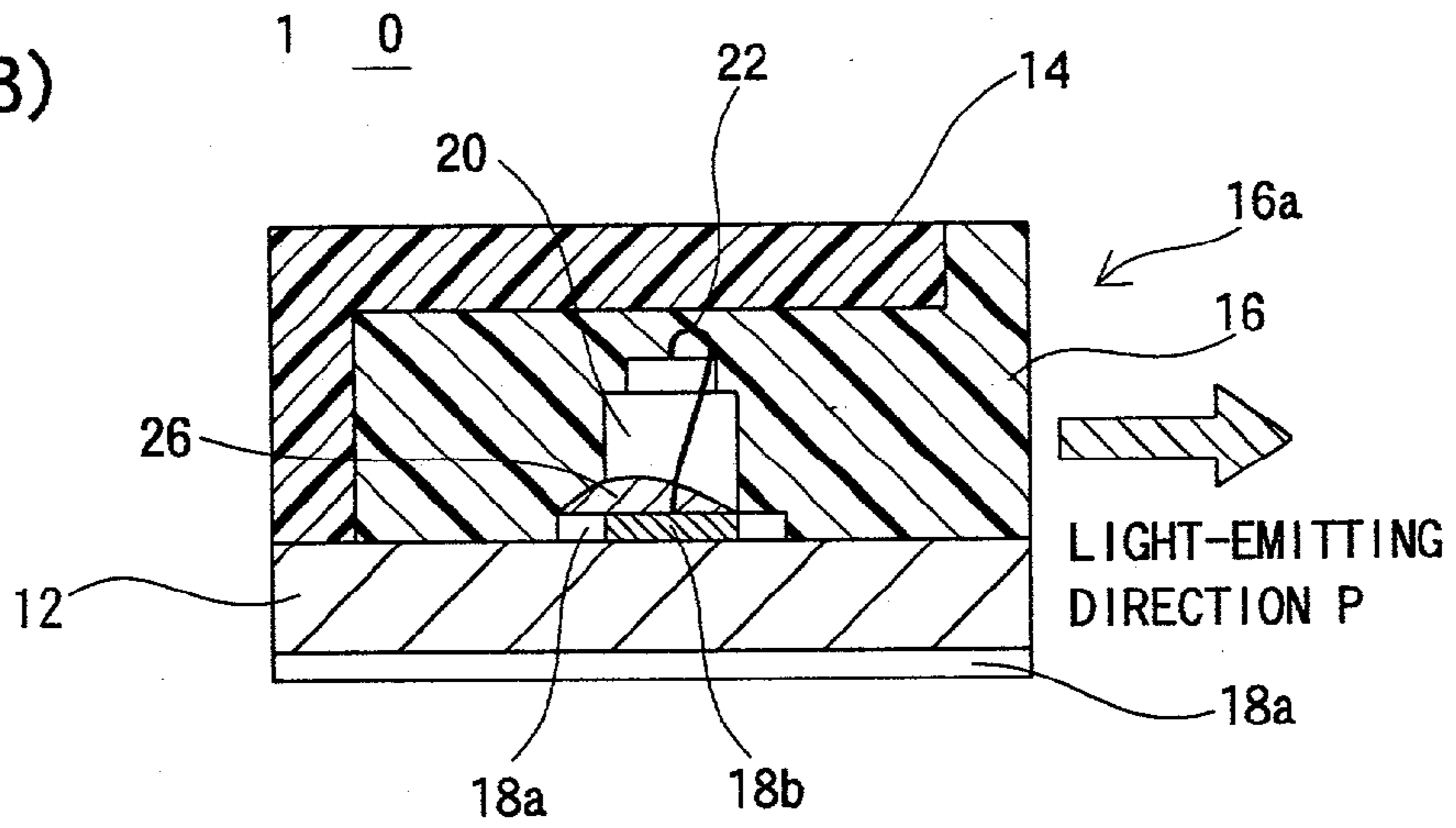

FIG. 12

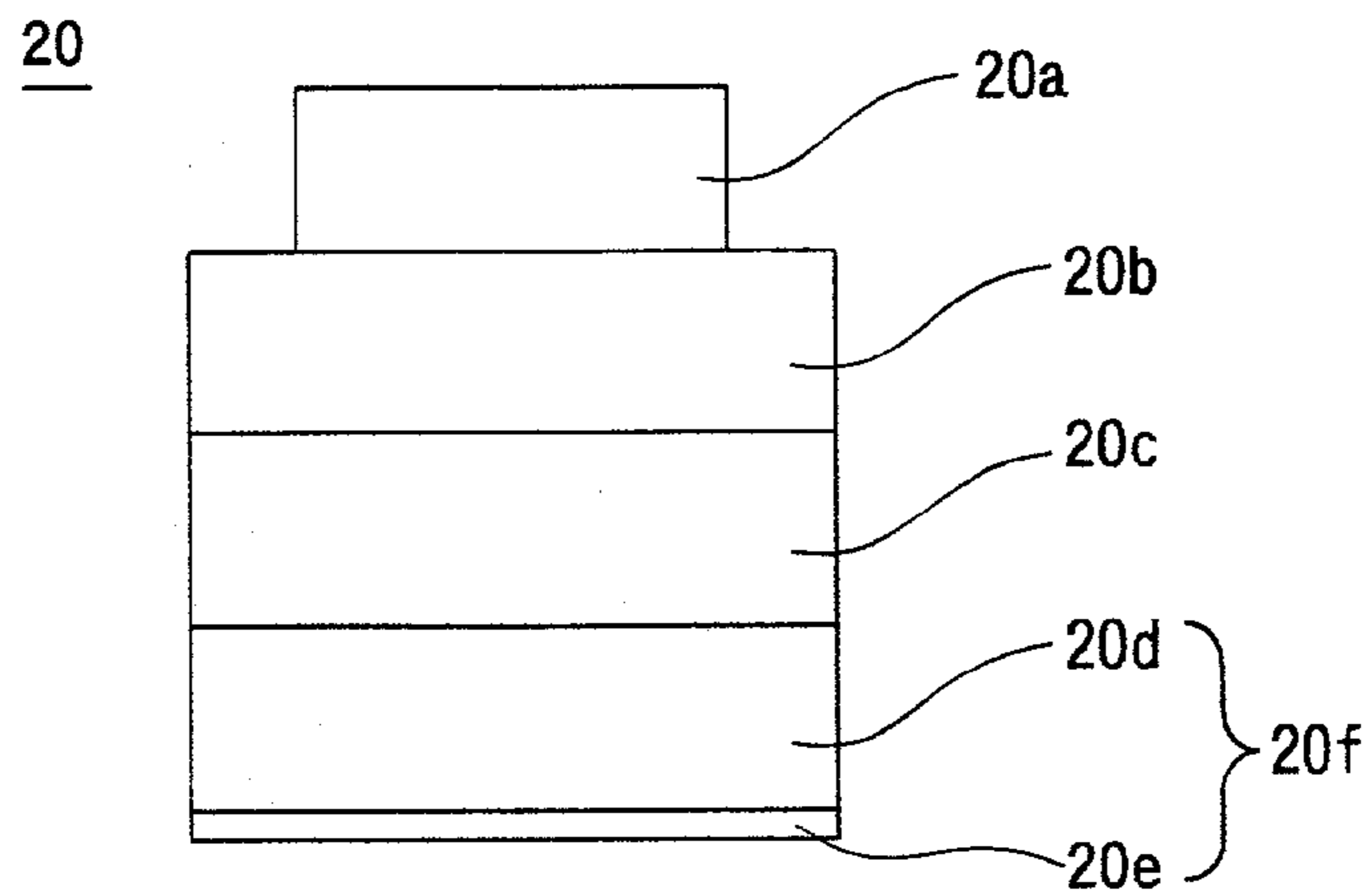

FIG. 13(A)

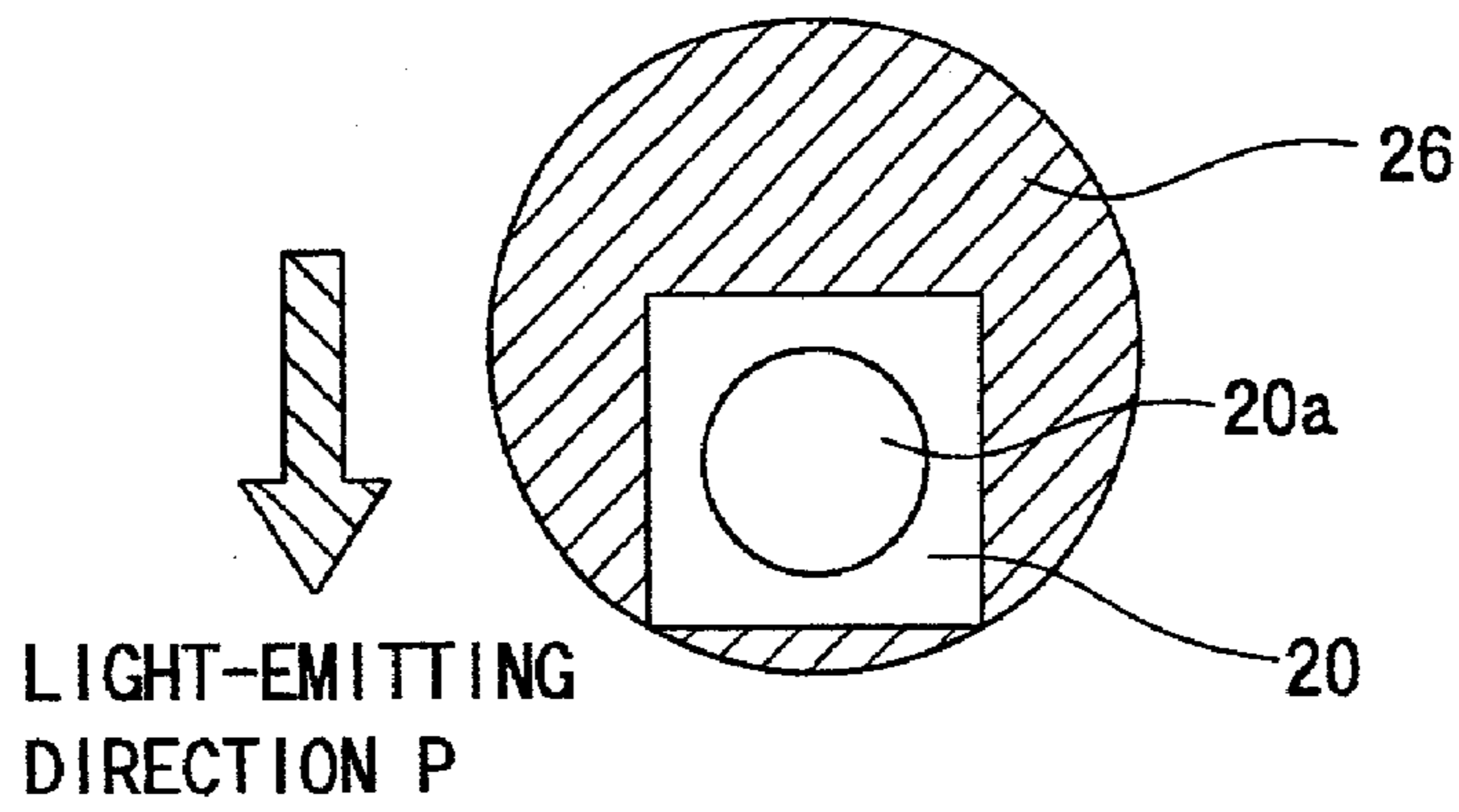

FIG. 13(B)

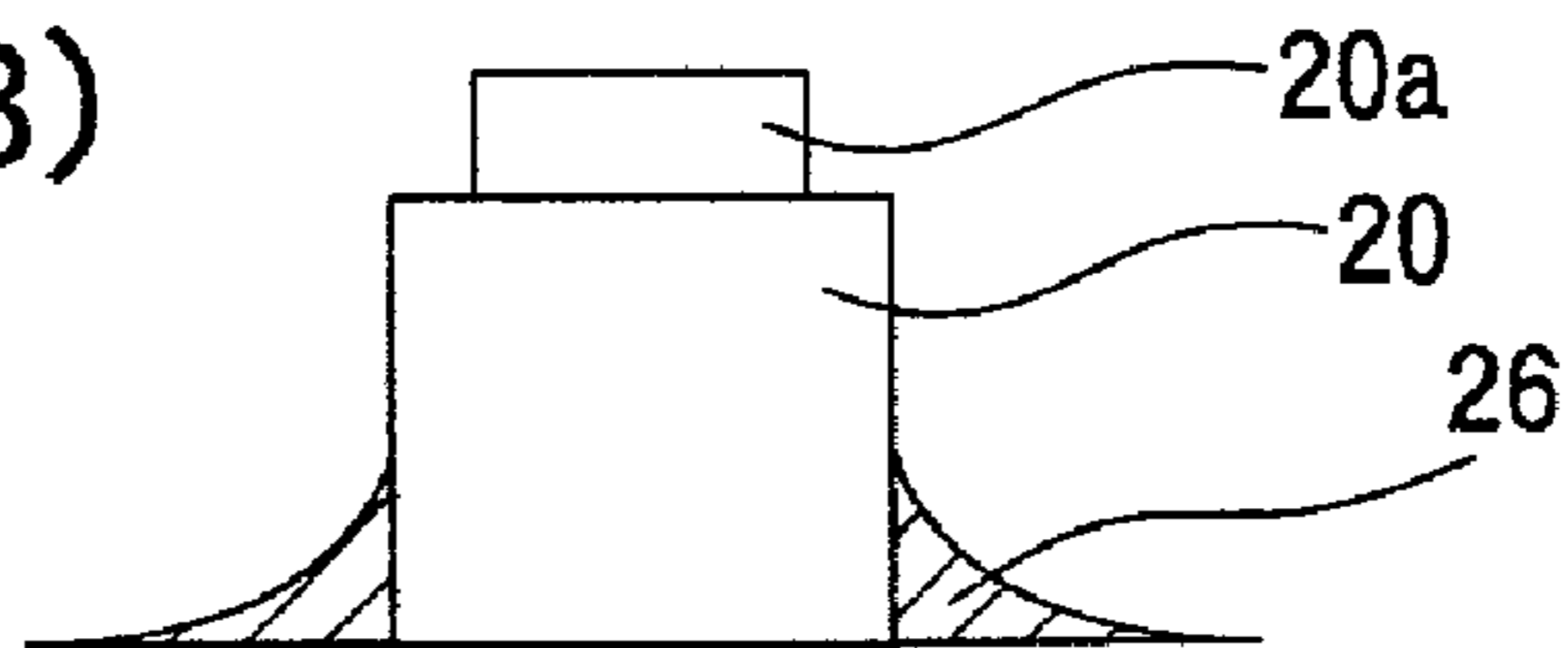

FIG. 13(C)

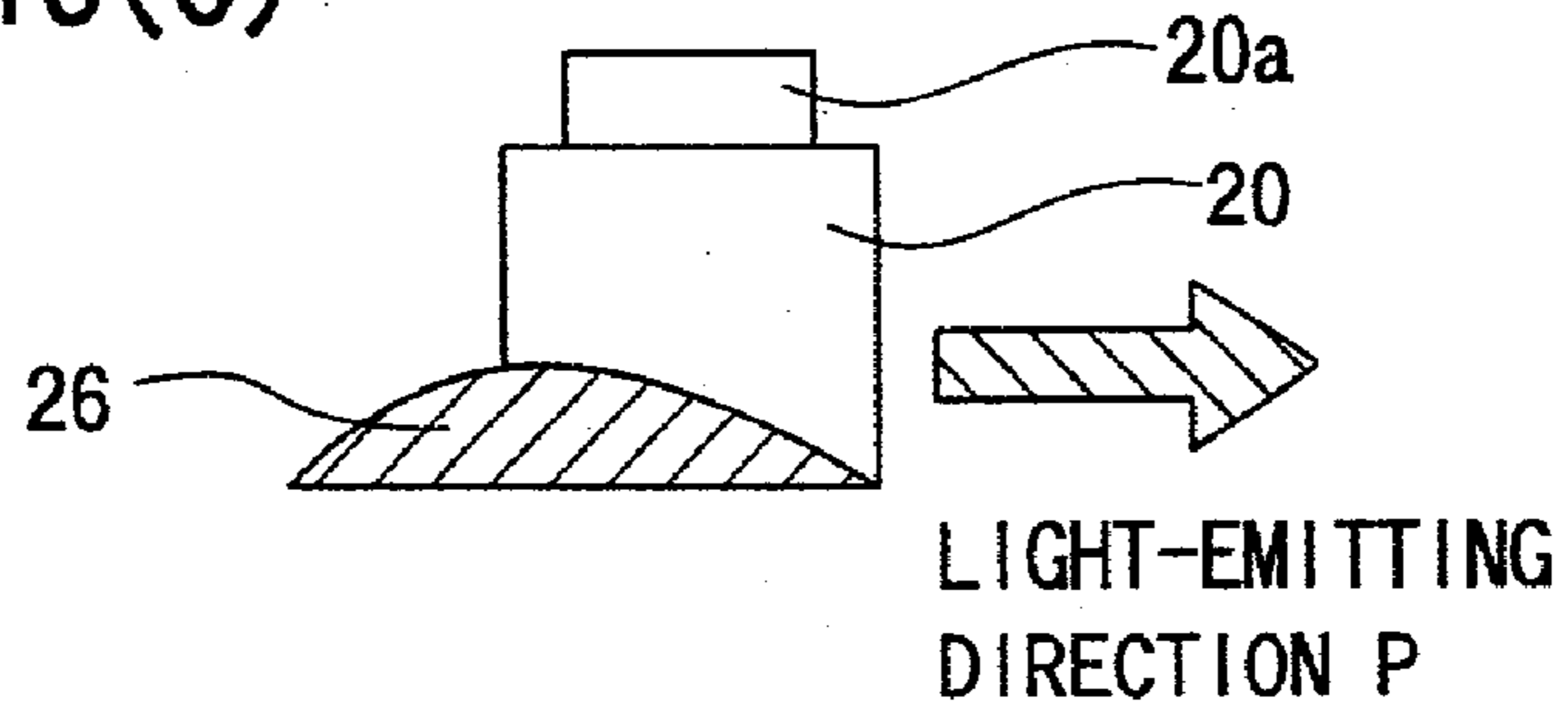

FIG. 13(D)

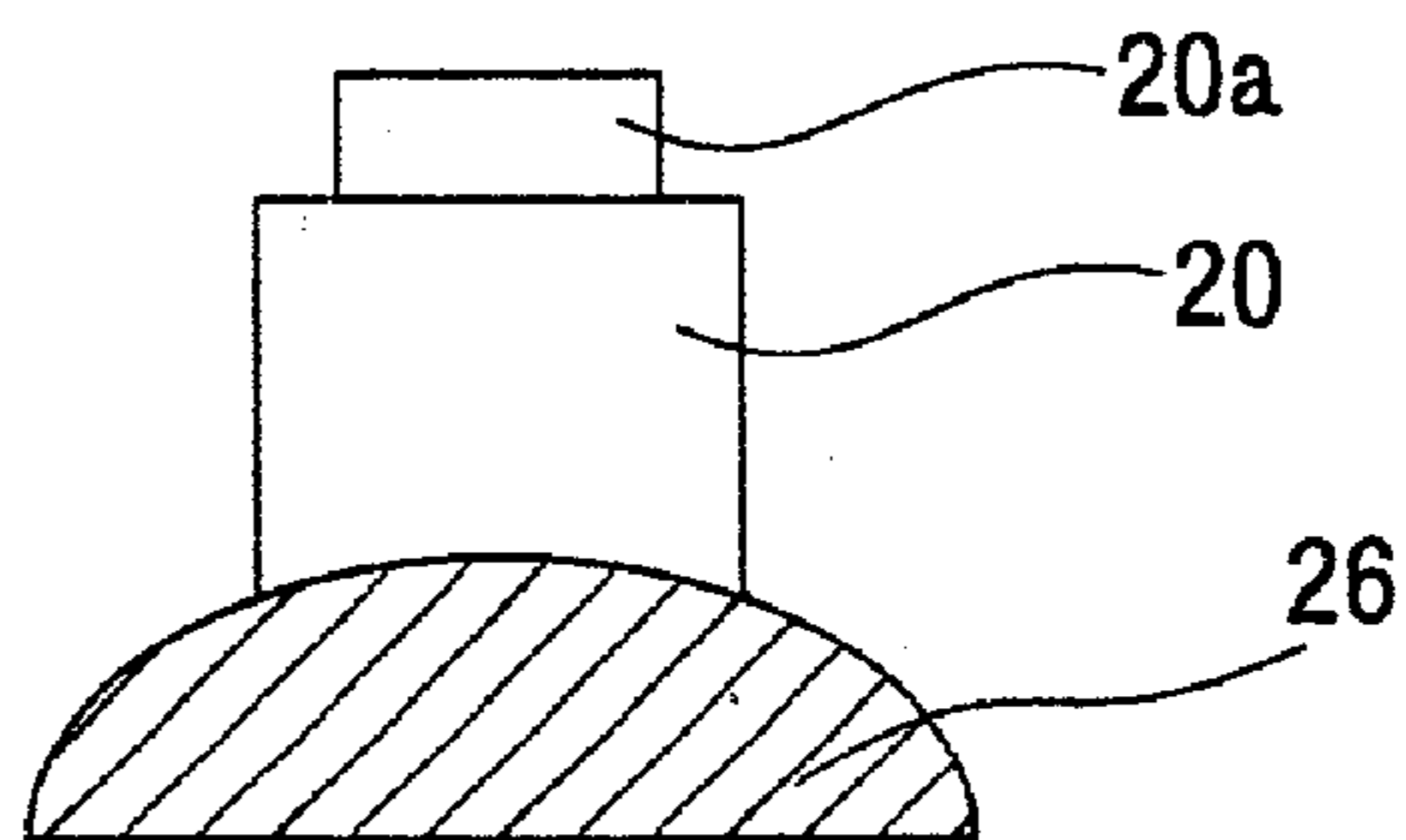

FIG. 14(A)

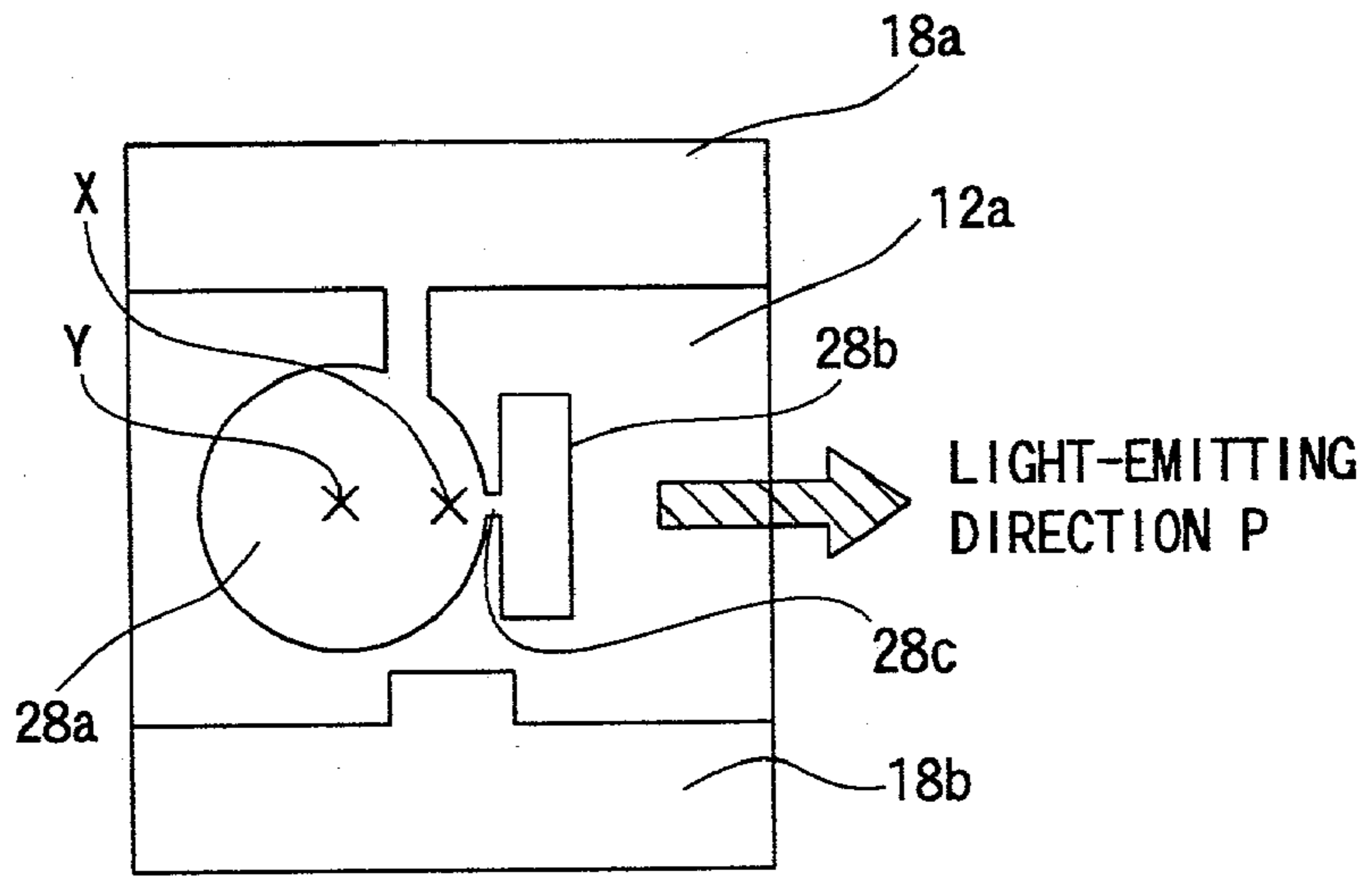

FIG. 14(B)

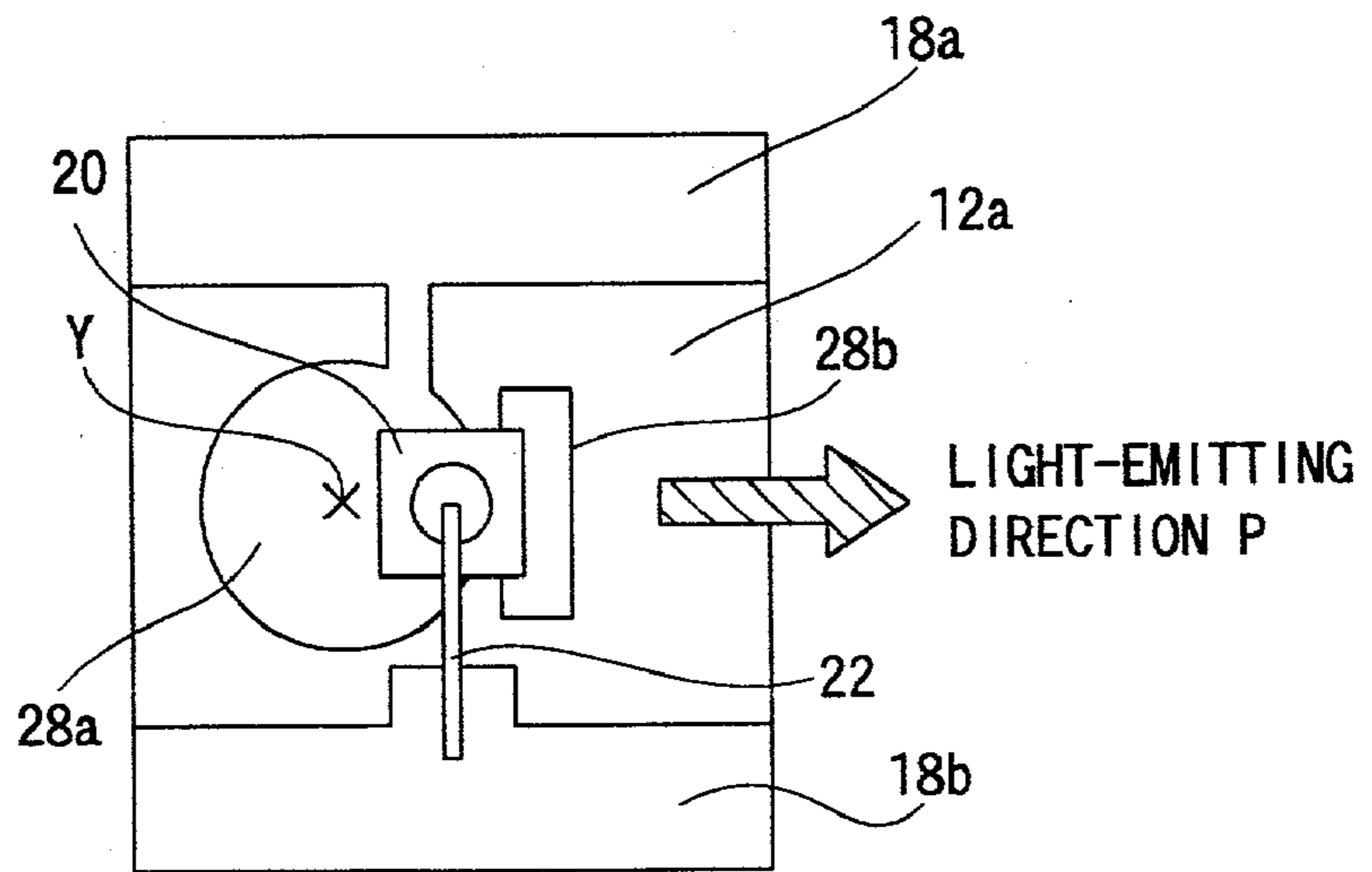

FIG. 15(A)

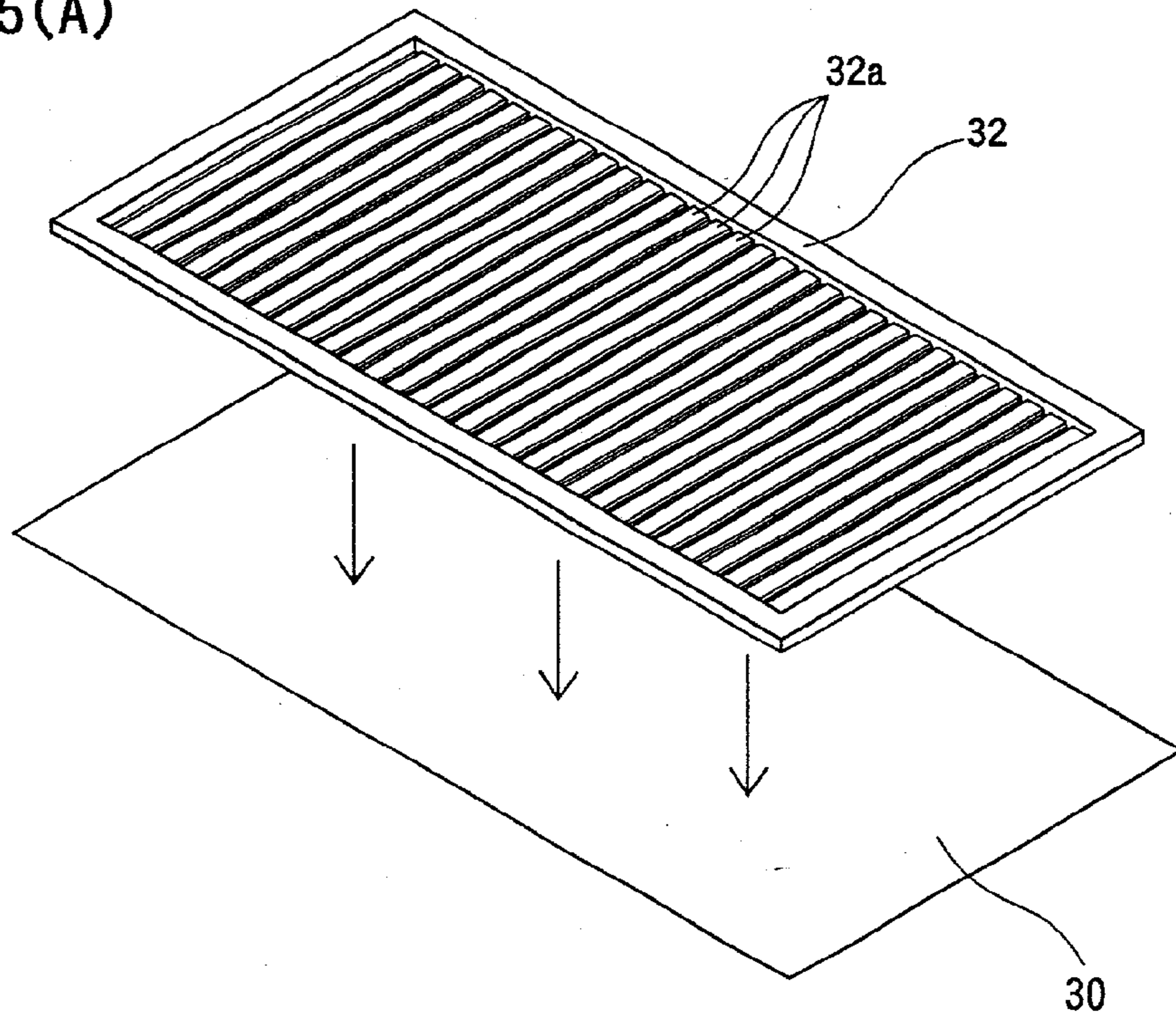
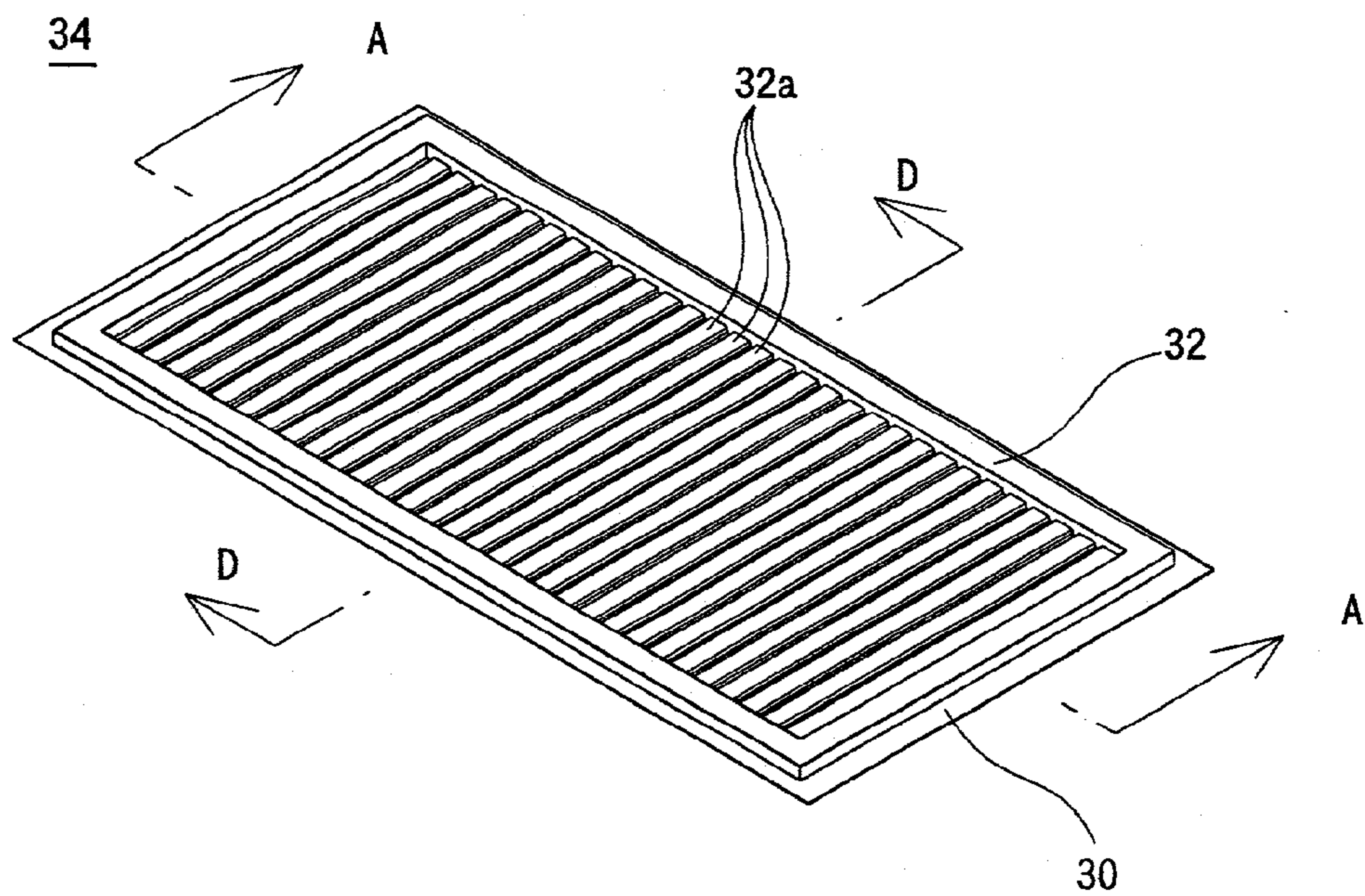

FIG. 15(B)



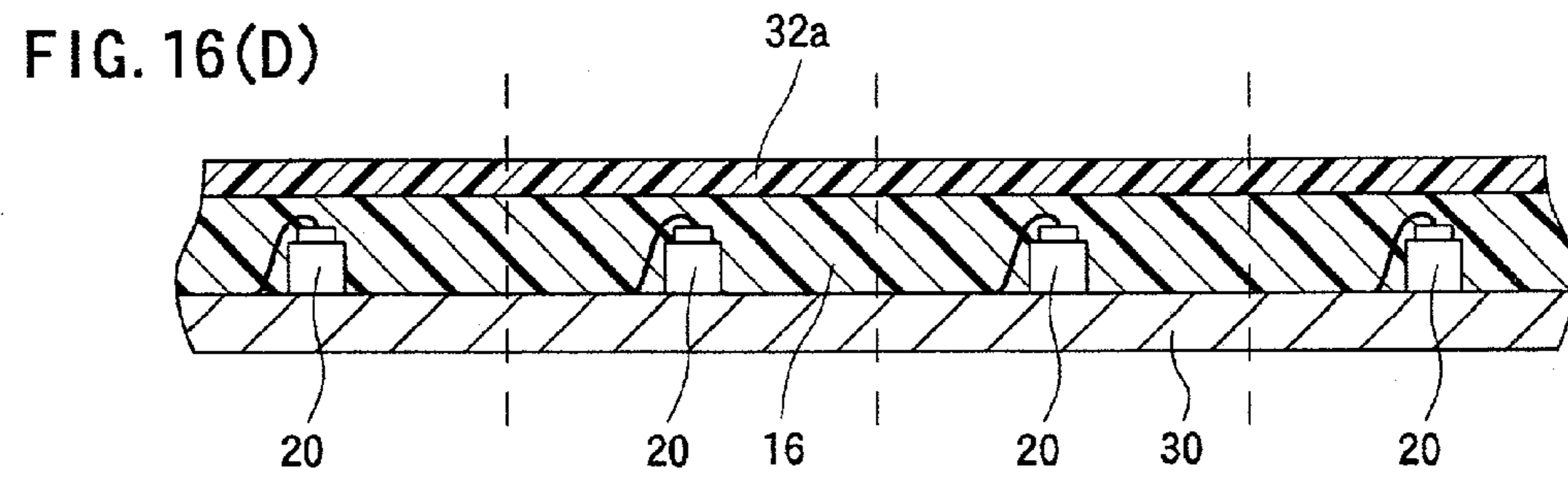
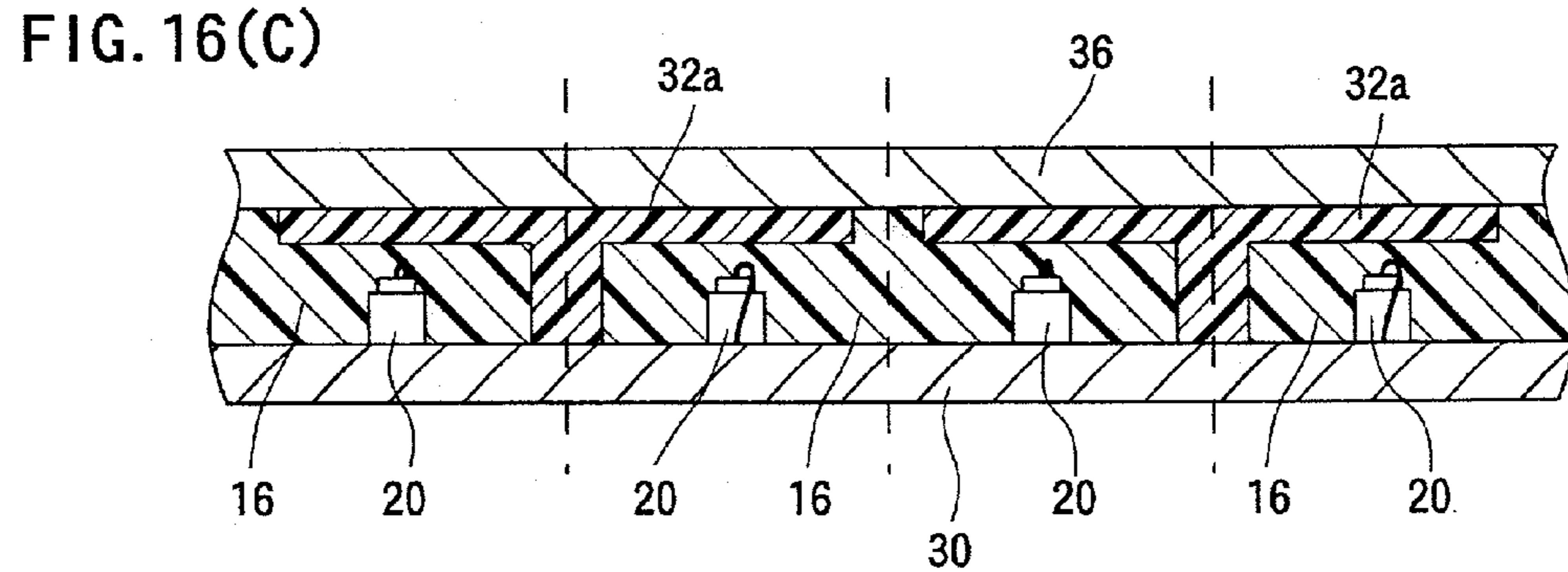
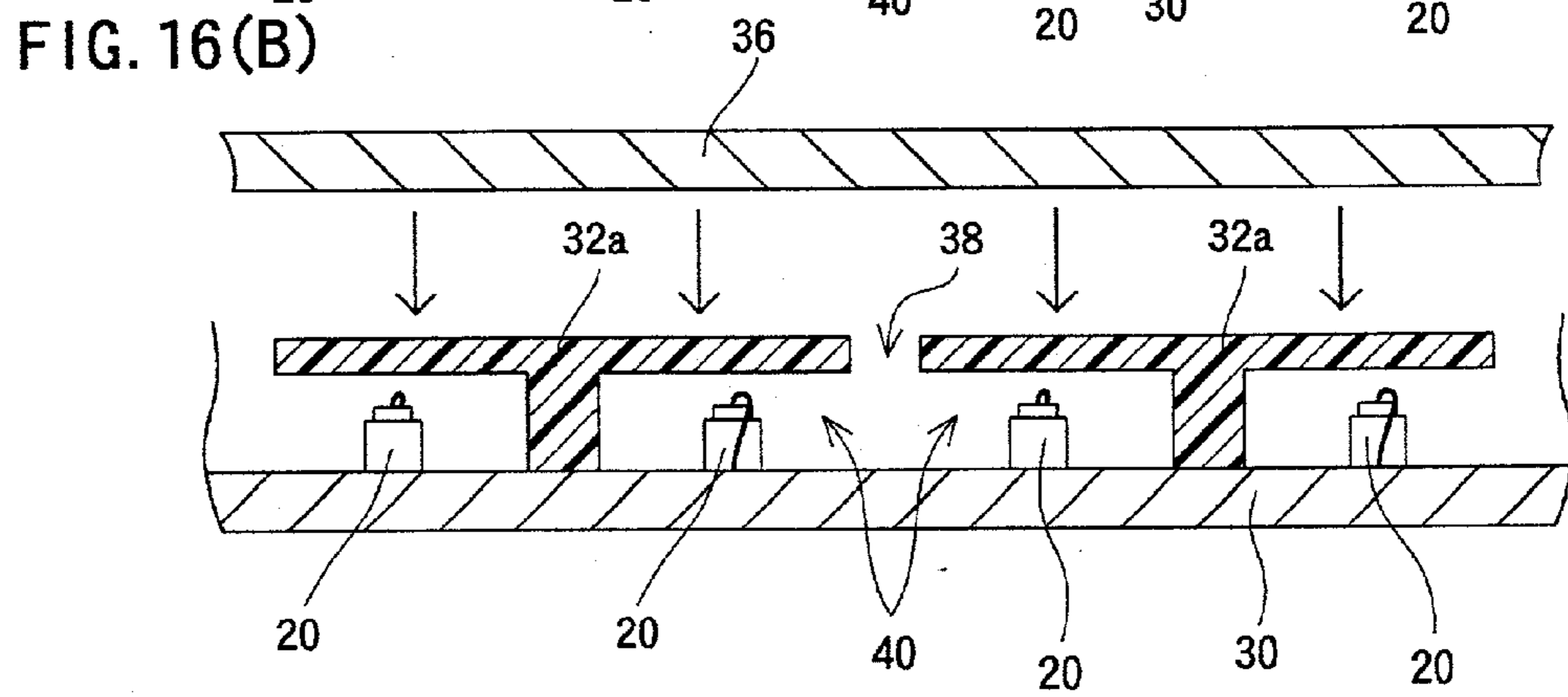
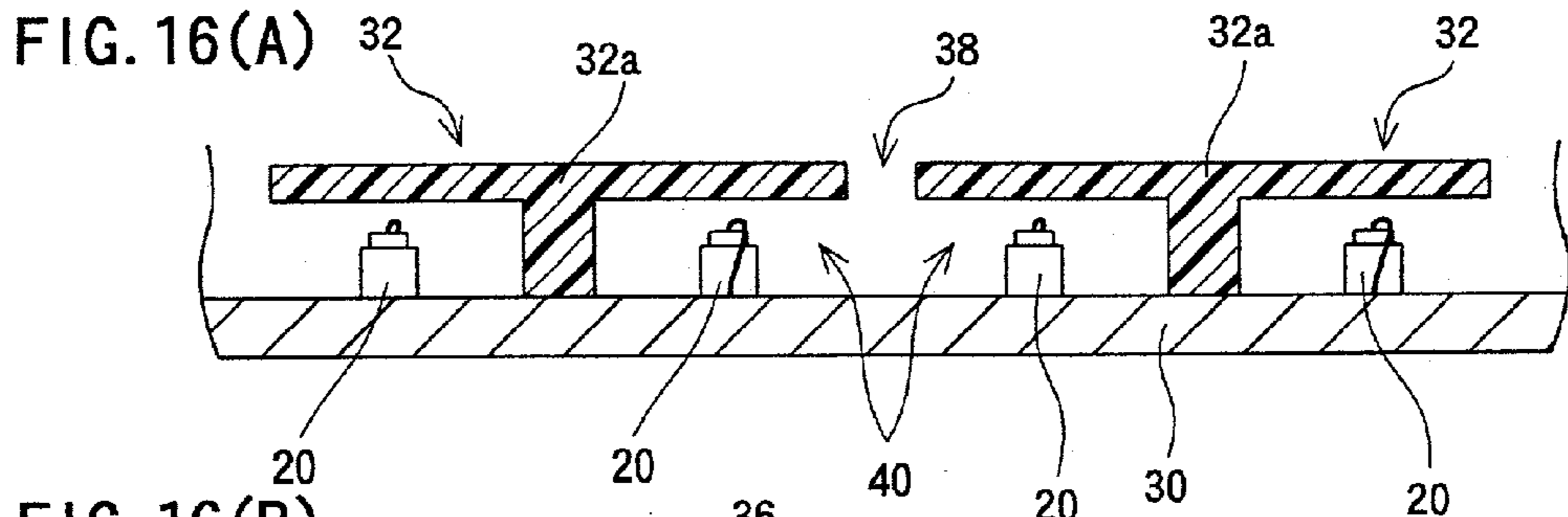

FIG. 17(A)

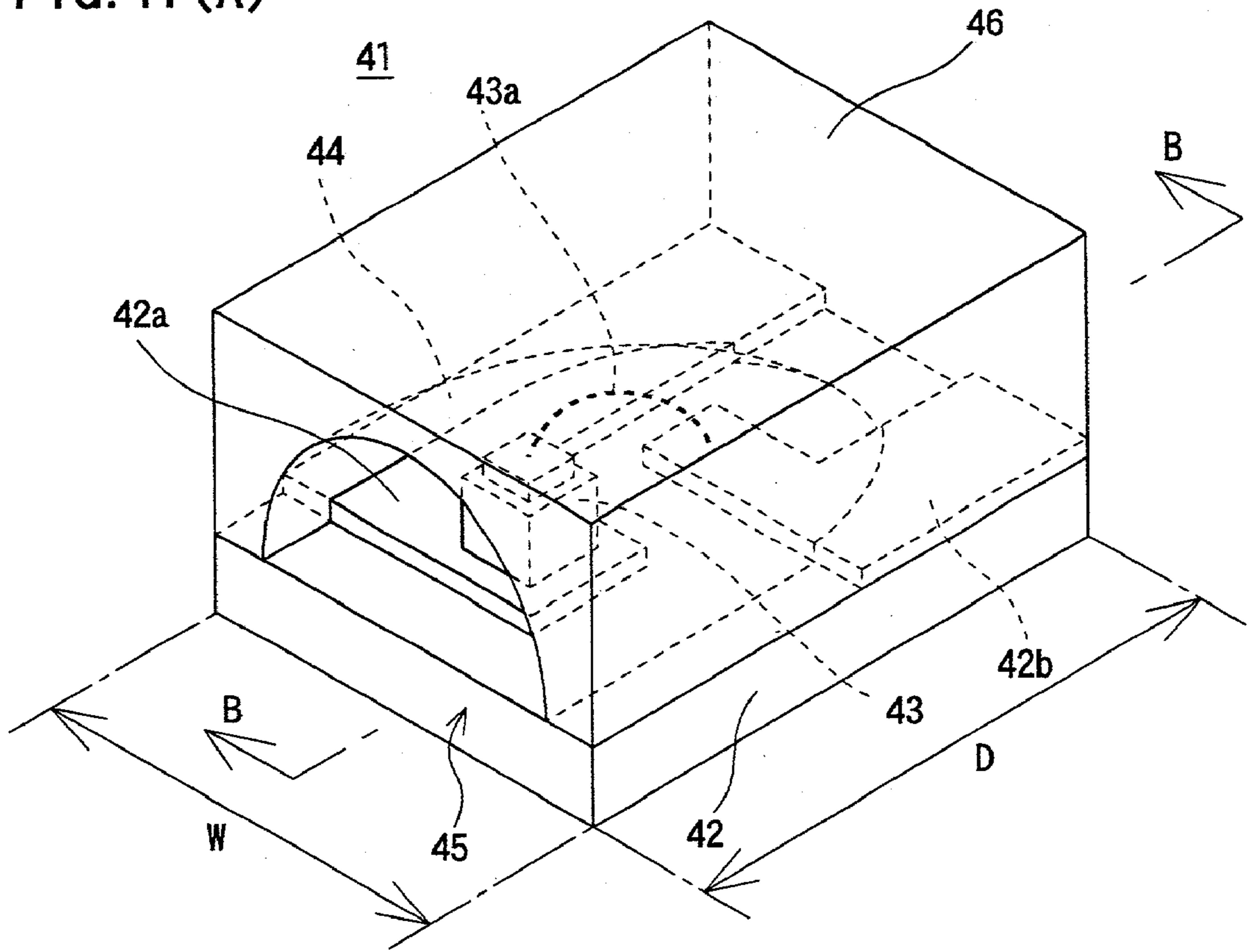

FIG. 17(B)

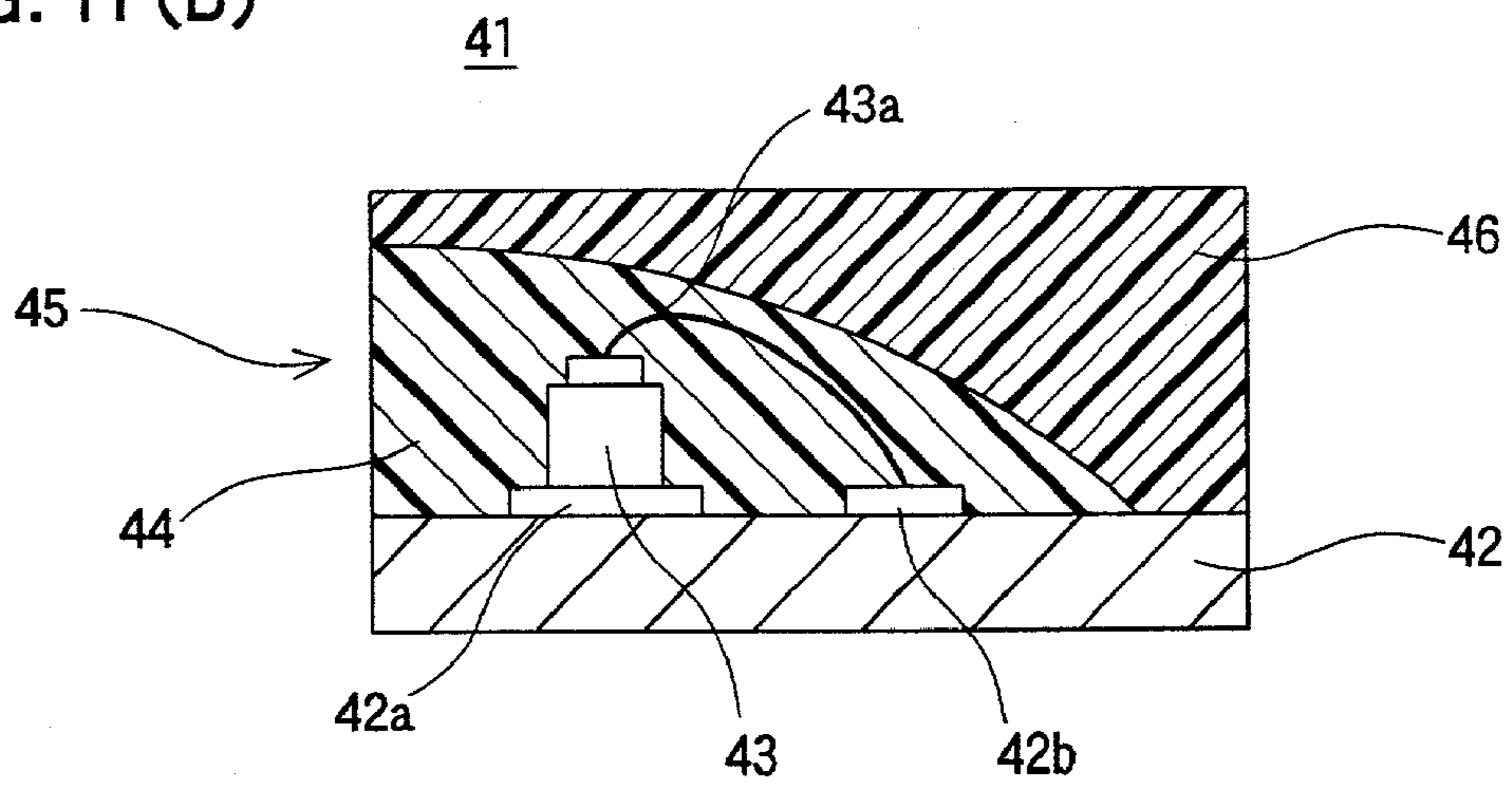

FIG. 18(A)

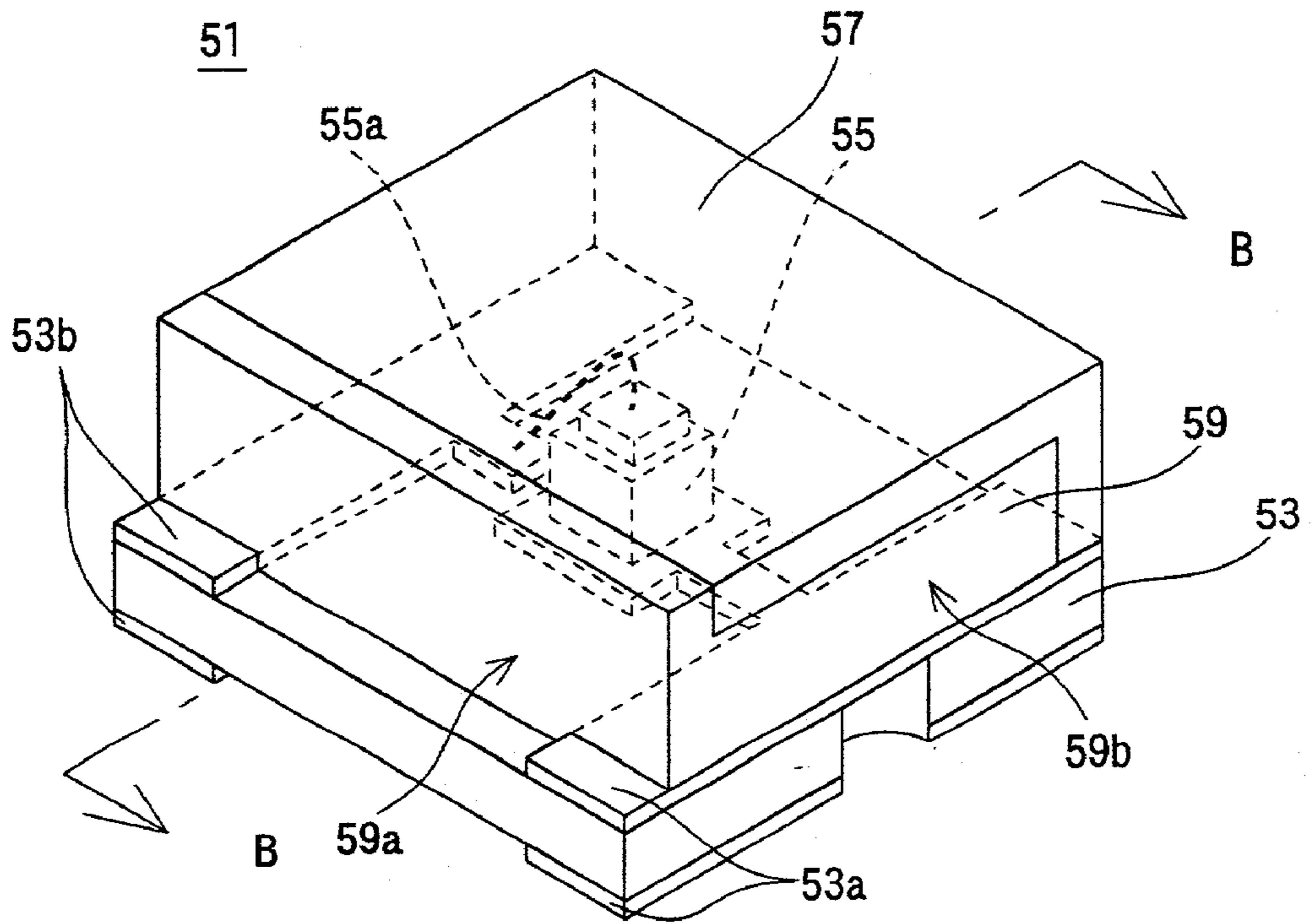

FIG. 18(B)

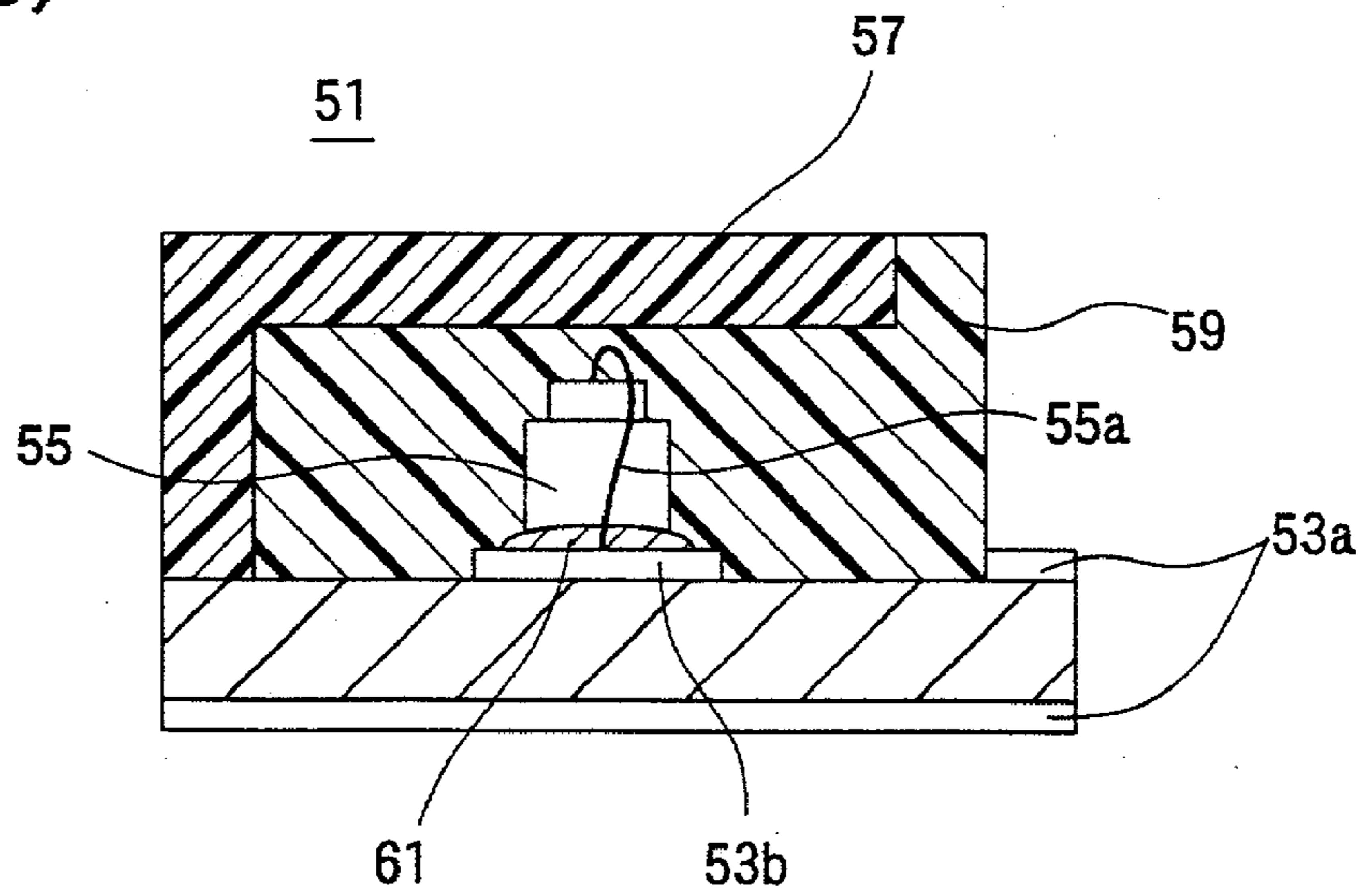

FIG. 19(A)

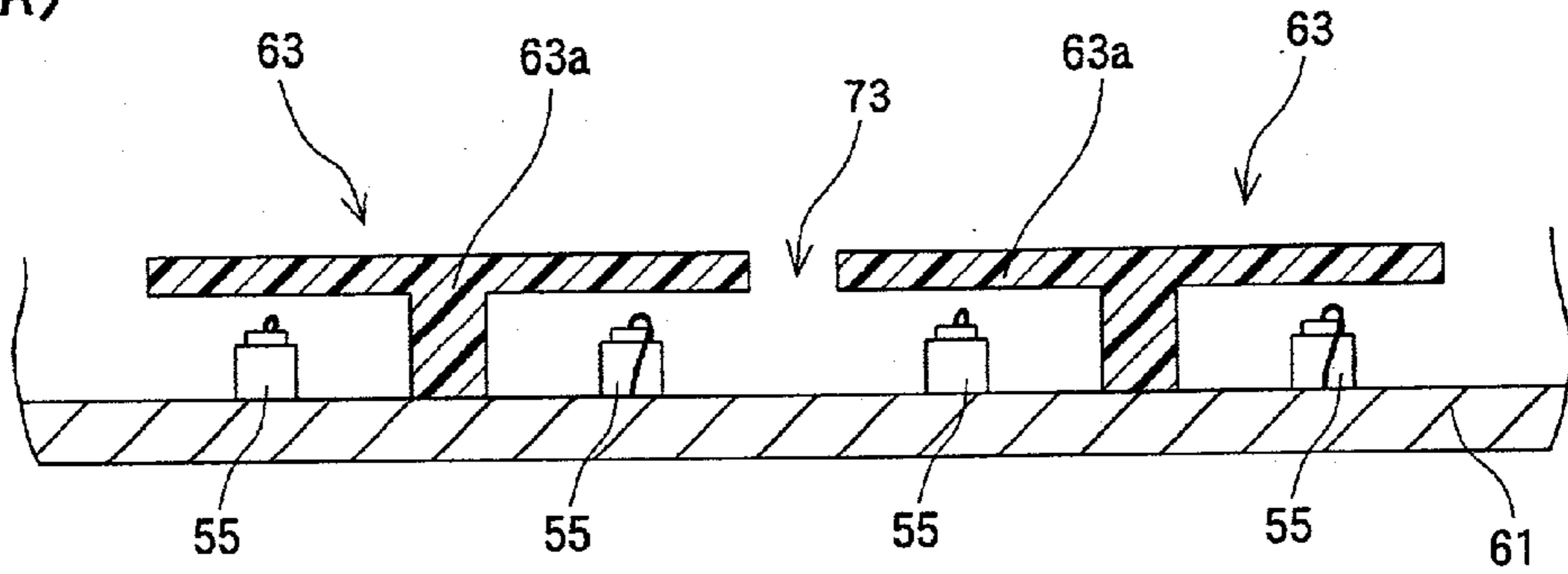

FIG. 19(B)

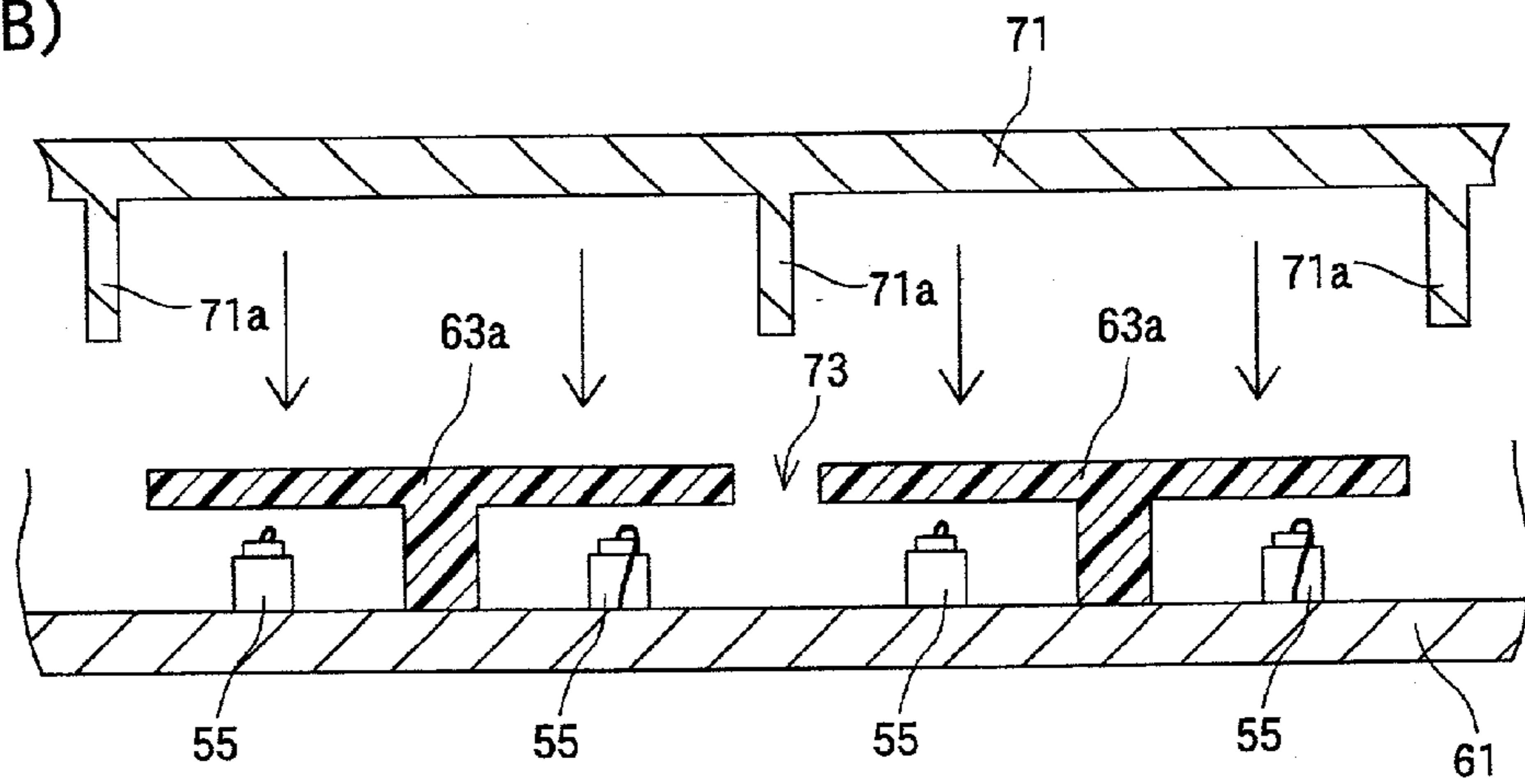
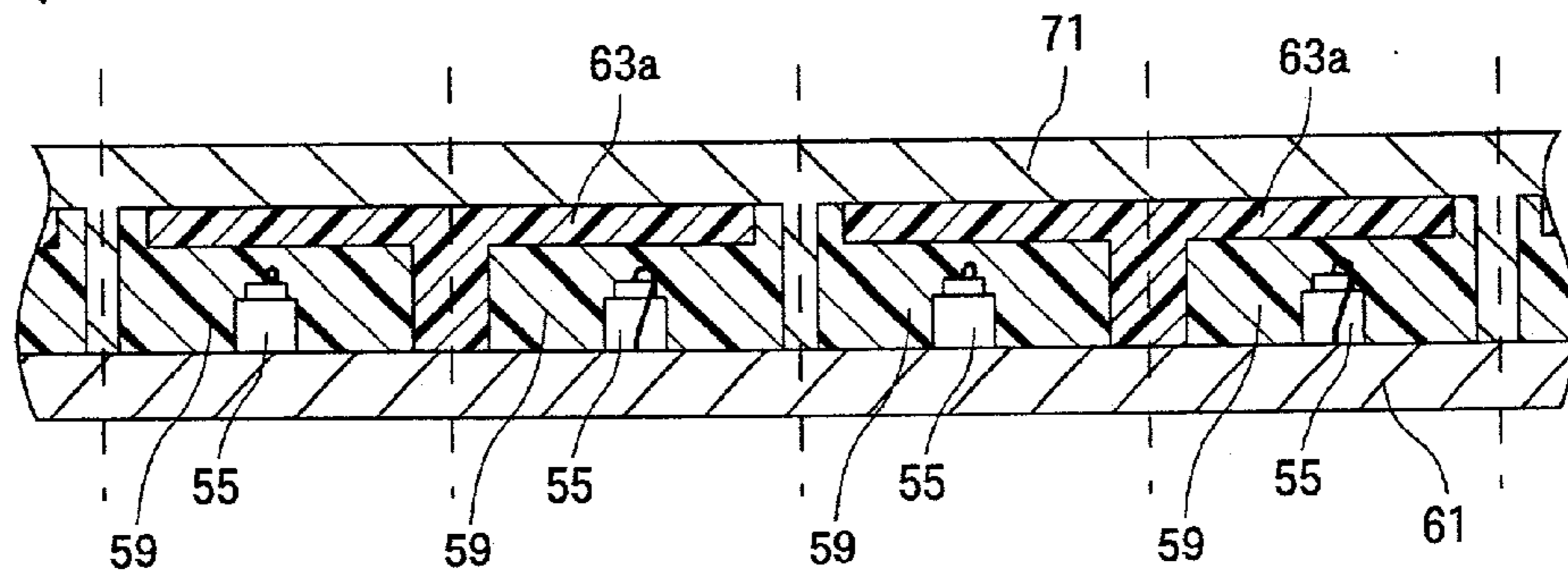

FIG. 19(C)



**EDGE-EMITTING LIGHT-EMITTING
SEMICONDUCTOR DEVICE AND METHOD OF
MANUFACTURE THEREOF**

TECHNICAL FIELD

[0001] The present invention relates to a side-emission type semiconductor light-emitting device and a manufacturing method thereof. More specifically, the present invention relates to a side-emission type semiconductor light-emitting device in which an LED chip is bonded onto an electrode on a substrate, and a manufacturing method thereof.

PRIOR ART

[0002] An example of this kind of a conventional side-emission type semiconductor light-emitting device and a manufacturing method thereof is disclosed in a Japanese Patent Laying-open No.5-315651 [H01L 33/00] laid-open on Nov. 26, 1993. A side-emission type semiconductor light-emitting device **1** manufactured in the disclosed manufacturing method is shown in FIG. 17(A). According to FIG. 17(A), an LED chip **43** is bonded onto electrodes **42a** and **42b** formed on a substrate **42**. A transparent or translucent synthetic resin **44** is formed so as to cover the LED chip **43**. As can be understood from FIG. 17(B) of a cross-sectional view at a line XVIB-XVIB in FIG. 17(A), the transparent or translucent synthetic resin **44** has a smooth upper surface and a bulge toward a light-emitting surface **45**. Furthermore, a cover body **46** having a concave portion into which the transparent or translucent synthetic resin **44** is fitted is formed so as to cover the transparent or translucent synthetic resin **44**. The cover body **46** is formed of a resin having opacity and reflectivity, and a light emitted from the LED chip **43** to the direction different from the light-emitting surface **45** is reflected by the cover body **46**. Accordingly, the reflected light is also outputted from the light-emitting surface **45**, and a light-emitting efficiency in the side surface direction is thus improved.

[0003] However, since in the above-described prior art a gold wire (bonding wire) **43a** for electrically connecting between the LED chip **43** and the electrode **42b** is bonded in a vertical direction with respect to the light-emitting surface **45**, a length **W** in a width direction of the semiconductor light-emitting device **1** is shorter than a length **D** in a depth direction thereof. Furthermore, the light-emitting surface **45** is formed on only a part of one side surface of the semiconductor light-emitting device **1** and therefore a light-emitting area becomes narrow. Due to this, when the semiconductor light-emitting device **1** is utilized as a backlight for a liquid crystal display (LCD) of electrical equipment such as a mobile phone and etc., there is a need to prevent an occurrence of a so-called dark portion by providing a relatively large number of semiconductor light-emitting devices **1** on a light guide plate.

[0004] For avoiding this, the applicant of the present invention has proposed a chip-type light-emitting device **51** as shown in FIG. 18(A) in a previous patent application No. 11-124410, i.e. Japanese Patent Laying-open No.2000-315825 laid-open on Nov. 14, 2000. According to FIG. 18(A), a substrate **53** is formed with electrodes **53a** and **53b**, and an LED chip **55** is bonded onto the electrodes **53a** and **53b**. In other words, as can be understood from FIG. 18(B) of a cross-sectional view at a line XVIIIB-XVIIIB in FIG.

18(A), the LED chip **55** is die-bonded onto the electrode **53a** by a bonding paste (hereinafter referred merely to as "DB paste") **61** and is wire-bonded onto the electrode **53b** by a bonding wire **55a**. A reflector (case) **57** formed of a resin having opacity and reflectivity is provided on the substrate **53** so as to enclose the LED chip **55**, and an opening portion formed by the substrate **53** and the case **57** is filled with a transparent or translucent resin **59**.

[0005] As can be understood from FIG. 18(B), the bonding wire **55a** is bonded in approximately parallel to a width direction of the chip-type semiconductor light-emitting device **51**, whereby a light-emitting surface is made larger. It is noted that in FIG. 18(A), surfaces **59a** and **59b** and a surface opposite to the surface **59b** which are formed of the transparent or translucent resin **59** shall be the light-emitting surface. However, although the chip-type semiconductor light-emitting device **51** can make the light-emitting surface larger, a mirror finish of the surface **59a** makes it difficult to manufacture the light-emitting device.

[0006] More specifically, when manufacturing the chip-type semiconductor light-emitting device **51**, a successive substrate **61** successively formed with the substrates **53** and a successive case **63** successively formed with the cases **57** are utilized so as to manufacture about a thousand of chip-type semiconductor light-emitting devices at a time. First, the successive substrate **61** and the successive case **63** are adhered to each other, a cross section is shown in FIG. 19(A). In FIGS. 19(A) to 19(c), although the successive substrate **61** is shown so as to extend only in a lateral direction, the successive substrate **61** also extends in a direction perpendicular to the paper sheet. Meanwhile, members **63a** included in the successive case **63** are formed with predetermined intervals in a lateral direction, and a cross section of the member **63a** is formed in a T-character form. Furthermore, the successive case **63** extends in a direction perpendicular to the paper sheet similarly to the successive substrate **61**. In other words, the member **63a** is formed in a stick form so that a cross section thereof becomes a T-character form. It is noted that the members **63a** are connected to each other at an end portion not shown, and the successive case **63** is thus formed.

[0007] After the successive substrate **61** and the successive case **63** are adhered to each other, a metal mold **71** is attached thereto as shown in FIG. 19(B), and the transparent or translucent resin **59** is, in turn, injected as shown in FIG. 19(C). When the transparent or translucent resin **59** is hardened, the metal mold **71** is detached, and then, dicing is performed at a portion shown by a dotted line in FIG. 19(C). Meanwhile, dicing is performed at every width of the device in a direction parallel to the paper sheet. Thus, a plurality of chip-type semiconductor light-emitting devices **51** can be obtained. The surface **59a** forming the light emitting surface is subjected to a mirror finish by a metal surface of a convex portion **71a** of the metal mold **71**.

[0008] However, since there is a need to fit the convex portion **71a** of the metal mold **71** into a space **73** of approximately 0.3 to 0.5 mm between respective members **63a**, it makes difficult to position the metal mold **71**. Furthermore, the convex portion **71a** is so thin that it is liable to be damaged. In addition, the metal mold **71** needs to be removed after the transparent or translucent resin **59** is hardened, and a friction makes it difficult to pull out the

metal mold 71. Since the surface 19a shown in FIG. 18(A) is subjected to the mirror finish, the light outputted from the LED chip 55 is refracted therefrom, and a light-emitting intensity in the side surface direction is thus decreased.

[0009] Furthermore, as can be understood from FIGS. 18(A) and 18(B), because the case 57 has a small area to be brought into contact with the substrate 53, and they are formed of different materials, it causes a decrease in adhesion between the case 57 and the transparent or translucent resin 59. Due to this, the case 57 can be separated by external shock with ease. In addition, since the LED chip 55 is die-bonded onto the electrode 53a by the DB paste 61, the lower part (base) of the LED chip 55 is covered by the DB paste 61. Therefore, the light outputted from the base portion of the LED chip 55 is blocked by the DB paste 61, and a light-emitting efficiency is thus decreased.

SUMMARY OF THE INVENTION

[0010] Therefore, it is a primary object of the present invention to provide a side-emission type semiconductor light-emitting device capable of improving a light-emitting intensity, and a manufacturing method thereof.

[0011] It is another object of the present invention to provide a side-emission type semiconductor light-emitting device capable of preventing a case from being separated, and a manufacturing method thereof.

[0012] It is another object of the present invention to provide a side-emission type semiconductor light-emitting device capable of improving a light-emitting efficiency in a desired light-emitting direction.

[0013] A side-emission type semiconductor light-emitting device according to the present invention comprises: a substrate formed with an electrode; an LED chip bonded onto the electrode; and a transparent or translucent resin with which the LED chip is molded, wherein the transparent or translucent resin has a light-emitting surface formed by a roughened surface being perpendicular to the substrate. Forming the light-emitting surface perpendicular to the substrate by a roughened surface, a light outputted by the LED chip is scattered by the light-emitting surface, whereby light-emitting intensity is improved. It is preferable dicing is utilized to form the light-emitting surface.

[0014] A manufacturing method of a side-emission type semiconductor light-emitting device according to the present invention comprises the following steps of: (a) mounting two reflectors having openings opposed with each other on a substrate mounted with an LED chip; (b) injecting a transparent or translucent resin at an opposing portion of the openings; and (c) dicing the transparent or translucent resin being hardened and the substrate at the opposing portion. In the side-emission type semiconductor light-emitting device manufactured, a dicing surface of the transparent or translucent resin shall be a light-emitting surface. Dicing makes the light-emitting surface a roughened surface, whereby a light outputted from the LED chip is scattered from the light-emitting surface. Due to this, the light-emitting intensity is improved.

[0015] A side-emission type semiconductor light-emitting device according to the present invention comprises: a substrate formed with an electrode; an LED chip bonded onto the substrate; a transparent or translucent resin with

which the LED chip is molded; and a reflector which reflects a light emitted from the LED chip, wherein the transparent or translucent resin has a convex portion, and the reflector has a concave portion to be fitted into the convex portion. By fitting the convex portion into the concave portion, the transparent or translucent resin and the reflector are integrated to each other, and the reflector is thus never separated with ease.

[0016] If the concave portion is made as a throughhole becoming larger from one main surface to other main surface of the reflector, even if an external force from the one main surface to the other main surface is applied to the reflector, the reflector is not easily fallen. Preferably, the one main surface is a surface brought into contact with the transparent or translucent resin, and the other main surface is a surface exposed to the outside. In a case the LED chip has a bonding wire extending from an upper surface of the chip, by forming the concave portion directly above the LED chip, the bonding wire can be housed in the concave portion, and therefore, it is possible to restrain the height of the side-emission type semiconductor light-emitting device.

[0017] A manufacturing method of a side-emission type semiconductor light-emitting device according to the present invention comprises the following steps of: (a) mounting a reflector formed with a concave portion on a substrate; (b) removing an organic matter adhering on a surface, including an inner surface of the concave portion, of the reflector; and (c) injecting a transparent or translucent resin between the reflector and the substrate up to the concave portion. By removing the organic matter, the transparent or translucent resin is easily entered into the concave portion, and adhesion between the reflector and the transparent or translucent resin is thus increased. By integrating the reflector with the transparent or translucent resin, it is possible to prevent the detachment of the reflector. It is preferable that a UV cleaning is utilized to remove the organic matter.

[0018] A side-emission type semiconductor light-emitting device according to the present invention comprises: a substrate formed with an electrode; and an LED chip bonded onto the electrode by a bonding paste, wherein the LED chip has a transparent or translucent base and a light-emitting layer formed thereon, and is mounted at a position deviated from an application position of the bonding paste to a light emitting surface side. A light outputted from the light-emitting layer is outputted from the light-emitting surface through the transparent or translucent base. Since the LED chip is bonded onto the position deviated from the application position of the bonding paste to the light-emitting surface side, the base is not covered by the bonding paste, and a light-emitting efficiency is thus improved.

[0019] It is preferable that the electrode includes an application area having a center deviated from a mounted position of the LED chip to an opposite direction of the light-emitting surface, whereby it is possible to determine the application position of the bonding paste with ease. More preferably, the electrode includes an auxiliary area formed closer to the light-emitting surface side than the application area and a narrow connecting portion connecting the application area and the auxiliary area. By forming the auxiliary area, the LED chip is securely bonded onto the electrode. Furthermore, by connecting the application area and the

auxiliary area with the narrow connecting portion, the bonding paste applied to the application area never enters the auxiliary area with ease. If the center of the application area is deviated from the center of the substrate to the opposite direction, the mounted position of the LED chip can be made at the same position as conventional position.

[0020] The above described objects and other objects, features, aspects and advantages of the present invention will become more apparent from the following detailed description of the present invention when taken in conjunction with the accompanying drawings.

BRIEF DESCRIPTION OF THE DRAWINGS

[0021] FIG. 1 is an illustrative view showing one embodiment of the present invention;

[0022] FIG. 2(A) is a cross-sectional view of a light-emitting device at a line IIA-IIA shown in FIG. 1;

[0023] FIG. 2(B) is a cross-sectional view of the light-emitting device at a line IIB-IIB shown in FIG. 1;

[0024] FIG. 3(A) is an illustrative view showing a successive substrate and successive case used for manufacturing the light-emitting device shown in FIG. 1;

[0025] FIG. 3(B) is an illustrative view showing a laminated body in which the successive case adheres to the successive substrate;

[0026] FIG. 4(A) is an illustrative view showing a step to manufacture the laminated body;

[0027] FIG. 4(B) is an illustrative view showing a step to apply a metal mold to the laminated body;

[0028] FIG. 4(C) is an illustrative view showing a step to inject a transparent or translucent resin into the laminated body applied with the metal mold;

[0029] FIG. 4(D) is an illustrative view showing a step to make dicing on the laminated body;

[0030] FIG. 5 is an illustrative view showing another embodiment of the present invention;

[0031] FIG. 6(A) is a cross-sectional view of the light-emitting device at a line VIA-VIA shown in FIG. 5;

[0032] FIG. 6(B) is a cross-sectional view of the light-emitting device at a line VIB-VIB shown in FIG. 5.

[0033] FIG. 7(A) is an illustrative view showing a successive substrate and a successive case used for manufacturing the light-emitting device shown in FIG. 5;

[0034] FIG. 7(B) is an illustrative view showing a laminated body in which the successive case adheres to the successive substrate;

[0035] FIG. 8(A) is an illustrative view showing a step to manufacture the laminated body;

[0036] FIG. 8(B) is an illustrative view showing a step to apply a metal mold to the laminated body;

[0037] FIG. 8(C) is an illustrative view showing a step to inject a transparent or translucent resin into the laminated body applied with the metal mold;

[0038] FIG. 8(D) is an illustrative view showing a step to making dicing on the laminated body;

[0039] FIG. 9 is a cross-sectional view showing a modified example of the light-emitting device shown in FIG. 5;

[0040] FIG. 10 is an illustrative view showing another embodiment of the present invention;

[0041] FIG. 11(A) is a cross-sectional view of the light-emitting device at a line XA-XA shown in FIG. 10;

[0042] FIG. 11(B) is a cross-sectional view of the light-emitting device at a line XB-XB shown in FIG. 10;

[0043] FIG. 12 is an illustrative view showing an LED chip shown in FIG. 11;

[0044] FIG. 13(A) is an illustrative view when the LED chip and a DB paste bonded onto an electrode are viewed from the upper side;

[0045] FIG. 13(B) is an illustrative view when the LED chip and the DB paste bonded onto the electrode are viewed from a light-emitting surface (front side);

[0046] FIG. 13(C) is an illustrative view when the LED chip and the DB paste bonded onto the electrode are viewed from the side surface;

[0047] FIG. 13(D) is an illustrative view when the LED chip and the DB paste bonded onto the electrode are viewed from an opposite side (back surface) of the light-emitting surface;

[0048] FIG. 14(A) is an illustrative view showing one example of the electrode formed on the substrate;

[0049] FIG. 14(B) is an illustrative view showing a state that the LED chip is mounted on the electrode;

[0050] FIG. 15(A) is an illustrative view showing a successive substrate and a successive case utilized in the light-emitting device shown in FIG. 10;

[0051] FIG. 15(B) is an illustrative view showing a laminated body in which the successive case adheres to the successive substrate;

[0052] FIG. 16(A) is an illustrative view showing a step to manufacture the laminated body;

[0053] FIG. 16(B) is an illustrative view showing a step to apply a metal mold to the laminated body;

[0054] FIG. 16(C) is an illustrative view showing a step to inject a transparent or translucent resin into the laminated body applied with the metal mold;

[0055] FIG. 16(D) is an illustrative view showing a step to make dicing on the laminated body;

[0056] FIG. 17(A) is an illustrative view showing one example of a conventional side-emission type semiconductor light-emitting device;

[0057] FIG. 17(B) is a cross-sectional view of the side-emission type semiconductor light-emitting device at a line XVIB-XVIB shown in FIG. 17(A);

[0058] FIG. 18(A) is an illustrative view showing one example of a side-emission type semiconductor light-emitting device as a background art of the present invention;

[0059] FIG. 18(B) is a cross-sectional view of the side-emission type semiconductor light-emitting device at the line XVIIIB-XVIIIB shown in FIG. 18(A);

[0060] FIG. 19(A) is an illustrative view showing a step to bond a successive case to a successive substrate when manufacturing the side-emission type semiconductor light-emitting device shown in FIG. 18(A);

[0061] FIG. 19(B) is an illustrative view showing a step to apply a metal mold to the successive case bonded to the successive substrate; and

[0062] FIG. 19(C) is an illustrative view showing a step to inject a transparent or translucent resin into the successive case applied with the metal mold.

BEST FORM FOR PRACTICING THE INVENTION

[0063] Referring to FIG. 1, a side-emission type semiconductor light-emitting device (hereinafter referred merely to as "light-emitting device") 10 of this embodiment includes an insulating substrate (hereinafter referred merely to as "substrate") 12 formed of a glass epoxy or the like. On the substrate 12, a reflector (case) 14 formed of a resin having opacity and reflectivity is provided. The substrate 12 is provided with electrodes 18a and 18b, and as can be understood from FIG. 2(A) of cross-sectional view at a line IIA-IIA in FIG. 1, a semiconductor light-emitting element (LED chip) 20 is die-bonded onto the electrode 18a by a DB paste (not shown). Meanwhile, as can be understood from FIG. 2(B) of a cross-sectional view at a line IIB-IIB in FIG. 1, the electrode 18b and the LED chip 20 are electrically connected with each other by a bonding wire 22 such as a gold wire and etc.

[0064] The electrode 18a is formed to extend from a front side to a backside of the substrate 12 via a throughhole 12a provided on a side surface of the substrate, and is structured to be directly mounted on the printed board (not shown) so as to be electrically connected thereto. Although not illustrated, the electrode 18b is structured in the same or similar manner. A space between the substrate 12 and the case 14 is charged or filled with a transparent or translucent resin 16 such as an epoxy resin or the like with which the LED chip 20 is molded.

[0065] It is noted that although each of the electrodes 18a and 18b is shown with a thickness in FIG. 1 and FIGS. 2(A) and 2(B), they are actually formed in a thin-film form. Meanwhile, as shown in FIG. 1, the throughhole 12a is covered by the electrode 18a at the front side of the substrate 12, whereby it is possible to prevent the transparent or translucent resin 16 from flowing into the backside of the substrate 12 during molding. Although not shown, the electrode 18b is structured in the same or similar manner.

[0066] As can be understood from FIGS. 2(A) and 2(B), the bonding wire 22 is bonded in a direction approximately parallel to a width direction W of the light-emitting device 10. Meanwhile, light-emitting surfaces are surfaces 16a, 16b and a surface opposite to the surface 16b, and are formed of the transparent or translucent resin 16. Furthermore, the light-emitting surfaces are perpendicular to the substrate 12, and each of which is formed by a roughened surface. Due to this, a light outputted from the LED chip 20 and a light reflected by the case 14 are scattered by the light-emitting surfaces. In other words, a light-emitting area is substantially enlarged, and a light-emitting intensity is improved.

[0067] Referring to FIG. 3(A), a successive substrate 30 is a substrate which is formed with a plurality of substrates 12

successively, and a successive case 32 is a case which is formed with a plurality of cases 14 successively. These successive substrate 30 and successive case 32 are utilized to manufacture the light-emitting device 10. The successive substrate 30 is, although not shown, formed with sets of the electrodes 18a and 18b in correspondence to the number of light-emitting devices 10 (approximately one thousand as in this embodiment) to be manufactured, and is bonded with the LED chips 20 in correspondence to the number of light-emitting devices 10 to be manufactured.

[0068] The successive case 32 is laminated on the successive substrate 30 as shown in FIG. 3(B), and a laminated body 34 can be thus obtained. As can be understood from FIG. 4(A) of a cross sectional view at a line IVA-IVA in FIG. 3(B), a cross section of a member 32a included in the successive case 32 is formed in a T-character form, and a plurality of members 32a are formed in a lateral direction with predetermined intervals. Meanwhile, the member 32a is formed to be successive in a direction perpendicular to the paper sheet. That is, the member 32a is formed in a stick form so that a cross section is a T-character form. It is noted that as can be understood from FIG. 3(A), respective members 32a are connected at their end portions, whereby a single successive case 32 is formed. Furthermore, the successive case 32 is adhered to the successive substrate 30 at a portion corresponding to a base or bottom of a vertical line of T-character.

[0069] When the laminated body 34 is obtained, the successive case 32 is subjected to a UV cleaning. More specifically, an ultraviolet ray is radiated for a predetermined time period (e.g. 3 minutes) in a state that the successive case 32 is adhered to the successive substrate 30. Such the UV cleaning can remove organic matter adhered to a surface of the successive case 32 (case 14), and can improve adhesion between the case 14 and the transparent or translucent resin 16. In other words, a bonded state between the organic matter and the case 14 is released, and it makes easy to connect or combine the transparent or translucent resin 16 injected and the case 14. After finishing the UV cleaning, the transparent or translucent resin 16 is injected into a portion (opposed portion) 38 that openings 40 each being formed by the successive substrate 30 and the successive case 32 are opposite to each other.

[0070] More specifically, a metal mold 36 formed in a flat plate form as shown in FIG. 4(B) is applied or attached to a top surface of the successive case 32, and the transparent or translucent resin 16 is injected into the opposed portion 38 as shown in FIG. 4(C). After finishing the injection, the transparent or translucent resin 16 is hardened, and the metal mold 36 is, in turn, removed from the successive case 32. The laminated body 34 being charged or filled with the transparent or translucent resin 16 is subjected to dicing by a dicing saw (not shown) at a position indicated by a dotted line in FIG. 4(C). As can be understood from FIG. 4(D) of a cross-sectional view at a line IVD-IVD of FIG. 3(B) which illustrates a state the transparent or translucent resin 16 has injected, the laminated body 34 is subjected to dicing every width of the case 14 (light-emitting device 10), whereby the light-emitting device 10 shown in FIG. 1 can be obtained in plural. Since a light-emitting surface of the light-emitting device 10 is formed by dicing, a light-emitting surface is formed with minute concavity and convexity in correspondence to roughness of a blade of the dicing saw. A

light outputted from the LED chip **20** is scattered from the light-emitting surface by the minute concavity and the convexity.

[0071] According to this embodiment, since a light-emitting surface improved in scattering of light is formed by dicing, it is possible to improve a light-emitting intensity with ease. Accordingly, in a case the light-emitting device is applied to a backlight of an LCD provided on electrical equipment and etc., it is possible to decrease the number of the light-emitting devices. In addition, since the metal mold utilized in injecting the transparent or translucent resin is in a flat plate form, it is easy to manufacture a metal mold.

[0072] Referring to **FIG. 5**, since a light-emitting device **10** of another embodiment is the same or similar to the device shown by **FIGS. 1 to 4** except for that a throughhole (hereinafter referred merely to as "hole") **24** is provided on an upper surface of the case **24**, a duplicated description will be omitted here as much as possible. As can be understood from **FIG. 5** and **FIGS. 6(A)** and **6(B)**, the case **14** is formed with the throughhole **24** on its top plate **14a**. The hole **24** has a shape that a truncated cone is turned upside down, and a diameter thereof becomes larger from a lower surface to an upper surface of the top plate **14a**. In addition, the hole **24** is charged or filled with the transparent or translucent resin **16**, and the case **14** and the transparent or translucent resin **16** are thus integrated to each other. In other words, the transparent or translucent resin **16** and the case **14** are integrated with each other in such a manner that a convex portion formed on the resin **16** is fitted into a concave portion formed on the case **14** (i.e. hole **24**), whereby both of them are integrated to each other.

[0073] Such the light-emitting device **10** is manufactured in the same or similar manner to the embodiments of **FIGS. 1 to 4**. Specifically, as shown in **FIG. 7(A)**, a successive case **32** formed with a plurality of holes **24** is laminated on a successive substrate **30**, whereby a laminated body **34** shown in **FIG. 7(B)** is formed. At this time, as can be understood from **FIG. 8(A)** of a cross-sectional view at a line VIII A-VIII A in **FIG. 7(B)**, a top portion of a bonding wire **22** is housed in the hole **24**. When the laminated body **34** is obtained after a UV cleaning for a predetermined time, a metal mold **36** is applied to the successive case **32** as shown in **FIG. 8(B)**, and then, a transparent or translucent resin **16** is injected into the successive case **32** as shown in **FIG. 8(C)**. When the resin **16** is hardened, the laminated body **34** is subjected to dicing as shown in **FIG. 8(D)**, and a plurality of light-emitting devices **10** are thus obtained.

[0074] According to this embodiment, by forming the hole **24** on the case **14** and by injecting the transparent or translucent resin **16** into the hole **24**, the case **14** and the transparent or translucent resin **16** are integrally formed. Due to this, even if a force is applied to the case **14** in the width direction **W** of the light-emitting device **10** shown in **FIG. 5**, the convex portion **16c** of the transparent or translucent resin **16** functions as a stopper, and detachment of the case **14** is thus prevented. Furthermore, since the diameter of the hole **24** is made larger toward upper direction, even if a force is applied in an upper direction **H** in **FIG. 5**, the case **14** is never separated.

[0075] In addition, although the diameter of the hole **24** is made larger toward the upper surface of the top plate **14a** so that it makes difficult to enter the transparent or translucent

resin **16** into the hole **24**, because of the improvement in adhesion between the transparent or translucent resin **16** and the case **14** by UV cleaning, the transparent or translucent resin **16** is easily intruded into the hole **24**.

[0076] Furthermore, since the hole **24** is formed directly above the LED chip **20**, a top **22a** of the bonding wire **22** extending from the upper surface of the chip is housed within the hole **24**. Due to this, even if the height of the case **14** is made lower, the bonding wire **22** is never brought into contact with the case **14**, and therefore, it is possible to prevent disconnection of the bonding wire **22** when attaching the case **14**. In addition, since the light-emitting device **10** can be formed in a thin type (thinner than above-described light-guide plate), the light outputted from the LED chip **20** is efficiently incident on the light-guide plate.

[0077] Furthermore, since a light outputted through the hole **24** to outside enables lighting test of the light-emitting device **10**, a lighting test apparatus for an upper-emission type semiconductor light-emitting device can be applied to the light-emitting device **10** of this embodiment. In other words, there is no need to provide another test apparatus, and there is no need to change positions of optical sensors provided on the test apparatus. In the lighting test, an amount of the light-emission from the light-emitting surface (side surfaces) may be evaluated by multiplying a ratio of an area of the light-emitting surface and an area of the hole **24** by an amount of the light-emission from the hole **24**.

[0078] It is noted that in this embodiment the hole is formed in a shape that a truncated cone is turned upside down, but such a hole may be formed in a shape that a truncated cone is put upside up, i.e. in upward direction as shown in **FIG. 9**. In other words, a diameter of the hole may be made smaller toward the upper direction. In a case a hole has a form shown in **FIG. 5** embodiment, when a large force is applied in the upper direction **H**, a convex portion of a transparent or translucent resin is broken, and therefore, there is a fear disconnection of a wire might occur. In contrast, when a hole is formed to become smaller toward the upper direction, even if a case is separated by a large force in the upper direction, the disconnection of a bonding wire can be avoided.

[0079] Furthermore, if it is required only the adhesion between the case and the transparent or translucent resin is improved, the hole may be formed in a cylindrical form. However, when detaching the metal mold for forming the case, since friction of a portion brought into contact with the hole becomes larger, it is difficult to pull out the metal mold, and there is a fear that the successive case might be damaged. Accordingly, in this embodiment, a hole of tapered form that a diameter becomes larger toward the upper direction is formed in order to solve these problems.

[0080] In addition, in this embodiment, although the UV cleaning is made on the case (successive case), plasma cleaning and sputtering cleaning may be used to remove the organic matter; however, in the examination performed by the inventor, the UV cleaning made adhesion best, and in addition, the plasma cleaning and the sputtering cleaning have a problem that a vacuum system is needed, and thus the cleaning apparatus itself is expensive.

[0081] Furthermore, although a whole surface of the case (successive case) including an inner surface is cleaned in

this embodiment, if at least the inner surface of the hole is cleaned, it is possible to enter or intrude the transparent or translucent resin into the hole.

[0082] Referring to FIG. 10, since a light-emitting device 10 of another embodiment is the same or similar to that of FIGS. 1 to 4 except that an electrode 18a is formed as shown in FIG. 14(A), a duplicate description will be omitted as much as possible. It is noted since in this embodiment a relative position between a DB paste and an LED chip has a special significance, and therefore, a DB paste is particularly illustrated by giving a reference numeral "26". The DB paste 26 is illustrated by utilizing slant lines in FIG. 11(A), FIG. 11(B), FIG. 12, and FIGS. 13(A) to 13(D), but it is noted that the slant lines never show a cross-section.

[0083] As shown in FIG. 12, the LED chip 20 includes a p-type electrode (bonding pad) 20a to be connected to the bonding wire 22 and an n-type electrode 20e to be connected to the electrode 18a. The n-type electrode 20e is formed by a thin film similarly to the electrodes 18a and 18b. The LED chip 20 includes a p layer 20b, a light-emitting layer 20c and an n layer 20d which are laminated on the n-type electrode 20e in an order of the n layer 20d, the light-emitting layer 20c and the p layer 20b. Each of the p layer 20b and the n layer 20d is formed of a translucent or transparent semiconductor GaAs. Furthermore, the n-type electrode 20e is formed of a copper thin film or the like having reflectivity. Due to this, a light emitted from the light-emitting layer 20c is outputted to an outside of the LED chip 20 through the p layer 20b and the n layer 20d. Furthermore, a light emitted below the light-emitting device 20c is reflected from a surface of the n-type electrode 20e and outputted to the outside of the LED chip 20 via the n layer 20d.

[0084] Accordingly, in a case the LED chip 20 is die-bonded onto the electrode 18a by the DB paste 26, a base 20f including the n layer 20d and the n-type electrode 20e is covered with the DB paste 26, and the light outputted through the n layer 20d is thus blocked by the DB paste 26. For avoiding this, in this embodiment by die-bonding the LED chip 20 onto the position shown in FIGS. 13(A) to 13(D), a light in a light-emitting direction P can be utilized at maximum.

[0085] In other words, as shown in FIG. 13(A), the LED chip 20 is die-bonded onto the electrode 18a in a state that it is deviated from a center of the DB paste 26 to the downward direction (light-emitting direction P). Accordingly, when viewing the LED chip 20 from the side of the light-emitting surface 16a, a portion covered by the DB paste 26 is decreased at the light-emitting direction P side of the LED chip 20. Meanwhile, when viewing the LED chip 20 from a side opposing to the surface 16b, as shown in FIG. 13(C), an amount of the DB paste 26 is continuously decreased from the center of the DB paste 26 toward the light-emitting direction P. Furthermore, when viewing the LED chip 20 from a side opposing to the surface 16a, as shown in FIG. 13(D), the base 20f of the LED chip 20 is covered with the DB paste 26. This is because the surface opposing to the light-emitting surface 16a is closer to the center of the DB paste 26, and the DB paste 26 increases in amount.

[0086] In this manner, since the LED chip 20 is mounted in a state that it is deviated from the center of the DB paste 26 to the light-emitting surface 16a side, the electrode 18a

shown in FIG. 14(A) is formed. According to FIG. 14(A), the electrode 18a includes an application area 28a to which the DB paste 26 is to be applied and an auxiliary area 28b. The application area 28a is circular in shape, and a center Y is deviated from a center X of the substrate 12 toward the left (direction opposite to the light-emitting direction P). Meanwhile, the auxiliary area 28b is vertically-long rectangular in shape and formed at a right side (light-emitting direction P) of the application area 28a. Furthermore, the application area 28a and the auxiliary area 28b are connected to each other with a narrow connecting portion 28c.

[0087] When the DB paste 26 is dropped on the center Y of the application area 28a, the DB paste 26 spreads in approximately circular. As shown in FIG. 14(B), the LED chip 20 is mounted on the center X of the substrate 12. Due to this, a surface at a side of the light-emitting surface 16a of the LED chip 20 is never covered with the DB paste 26, and it is possible to prevent the light outputted to the light-emitting direction P from being blocked by the DB paste 26. Furthermore, by providing the auxiliary area 28b, it is possible to reliably connect the LED chip 20 to the electrode 18a. It is noted that in FIGS. 14(A) and 14(B), illustration of the DB paste 26 will be omitted to simply show the electrode 18.

[0088] A size of the application area 28a depends on an application amount and viscosity of the DB paste 26, and as the size of the application area 28a is determined, the position (center Y) of the application area 28a is also determined. Since the application area 28a and the auxiliary area 28b are connected (jointed) by the connecting portion 28c, it is possible to prevent the DB paste 26 from entering the auxiliary area 28b. That is, it is possible to decrease the amount of the DB paste 26 at the side of the light-emitting surface 16a.

[0089] Such the light-emitting device 10 is manufactured in the same or similar manner to the embodiment of FIGS. 1 to 4. That is, as shown in FIG. 15(A), the successive case 32 is laminated on the successive substrate 30, and the laminated body 34 shown in FIGS. 15(B) and 16(A) is, in turn, formed. When the laminated body 34 is formed, after UV cleaning for a predetermined time period, the metal mold 36 is applied to the successive case 32 as shown in FIG. 16(B), and the transparent or translucent resin 16 is injected into the successive case 32 as shown in FIG. 16(C). When the transparent or translucent resin 16 is hardened, the laminated body 34 is subjected to dicing at a portion shown by a dotted line in FIG. 16(D), and a plurality of light-emitting devices 10 are thus obtained.

[0090] According to this embodiment, since the mounted position of the LED chip 20 is deviated from the center Y of the DB paste 26 to the light-emitting surface 16a side, the light-emitting side of the LED chip 20 is never covered with the DB paste 26. In other words, because a light outputted to a desired direction is never blocked by the DB paste, it is possible to improve a light-emitting efficiency.

[0091] It is noted that an electrode is not limited to the shape shown in FIG. 14(A), and it is appropriate that a shape can determine an application position of the DB paste uniquely. Furthermore, if an electrode is formed as in FIG. 14(A) and an application position of a DB paste is changed, it is possible to manufacture the light-emitting device of this embodiment utilizing a conventional manufacturing device.

[0092] Although the present invention has been described and illustrated in detail, it is clearly understood that the same is by way of illustration and example only and is not to be taken by way of limitation, the spirit and scope of the present invention being limited only by the terms of the appended claims.

What is claimed is:

1. A side-emission type semiconductor light-emitting device, comprising:

- a substrate formed with an electrode;
- an LED chip bonded onto said electrode; and
- a transparent or translucent resin with which said LED chip is molded, wherein
 - said transparent or translucent resin has a light-emitting surface formed by a roughened surface being perpendicular to said substrate.

2. A side-emission type semiconductor light-emitting device according to claim 1, wherein said light-emitting surface is formed by dicing.

3. A manufacturing method of a side-emission type semiconductor light-emitting device, comprising the following steps of:

- (a) mounting two reflectors having openings opposed with each other on a substrate mounted with an LED chip;
- (b) injecting a transparent or translucent resin at an opposing portion of said openings; and
- (c) dicing said transparent or translucent resin being hardened and said substrate at said opposing portion.

4. A side-emission type semiconductor light-emitting device, comprising:

- a substrate formed with an electrode;
- an LED chip bonded onto said substrate;
- a transparent or translucent resin with which said LED chip is molded; and
- a reflector which reflects a light emitted from said LED chip, wherein said transparent or translucent resin has a convex portion, and said reflector has a concave portion to be fitted into said convex portion.

5. A side-emission type semiconductor light-emitting device according to claim 4, wherein said concave portion is a throughhole having a diameter which becomes larger from one main surface to other main surface of said reflector.

6. A side-emission type semiconductor light-emitting device according to claim 5, wherein said one main surface

is a surface brought into contact with said transparent or translucent resin, and said other main surface is a surface exposed to outside.

7. A side-emission type semiconductor light-emitting device according to any one of claims 4 to 6, wherein said LED chip has a bonding wire extending from a top surface, and said concave portion is formed directly above said LED chip.

8. A manufacturing method of a side-emission type semiconductor light-emitting device, comprising the following steps of:

- (a) mounting a reflector formed with a concave portion on a substrate;
- (b) removing an organic matter adhering to a surface, including an inner surface of said concave portion, of said reflector; and
- (c) injecting a transparent or translucent resin between said reflector and said substrate up to said concave portion.

9. A manufacturing method of a side-emission type semiconductor light-emitting device according to claim 8, wherein said reflector is subjected to UV cleaning in the step (b).

10. A side-emission type semiconductor light-emitting device, comprising:

- a substrate formed with an electrode; and
- an LED chip which is bonded onto said electrode by a bonding paste, wherein
 - said LED chip has a transparent or translucent base and a light-emitting layer formed thereon, and is mounted on a position deviated from an application position of said bonding paste to a light emitting surface side.

11. A side-emission type semiconductor light-emitting device according to claim 10, wherein said electrode includes an application area having a center deviated from a mounted position of said LED chip to an opposite direction of said light-emitting surface.

12. A side-emission type semiconductor light-emitting device according to claim 11, wherein said electrode further includes an auxiliary area formed closer to said light-emitting surface side than said application area and a narrow connecting portion connecting said application area and said auxiliary area.

13. A side-emission type semiconductor light-emitting device according to claim 11 or 12, wherein a center of said application area is deviated from a center of said substrate to said opposite direction.

* * * * *