



US 20020017612A1

(19) **United States**

(12) **Patent Application Publication**

Yu et al.

(10) **Pub. No.: US 2002/0017612 A1**

(43) **Pub. Date: Feb. 14, 2002**

(54) **ORGANIC DIODES WITH SWITCHABLE PHOTSENSITIVITY USEFUL IN PHOTODETECTORS**

provisional of provisional application No. 60/073,346, filed on Feb. 2, 1998.

**Publication Classification**

(76) Inventors: **Gang Yu**, Santa Barbara, CA (US);  
**Yong Cao**, Goleta, CA (US)

(51) **Int. Cl.<sup>7</sup> ..... G01T 1/24**

(52) **U.S. Cl. .... 250/370.11; 257/40**

Correspondence Address:

**E I DU PONT DE NEMOURS AND COMPANY**

**LEGAL DEPARTMENT - PATENTS**

**1007 MARKET STREET**

**WILMINGTON, DE 19898 (US)**

(57) **ABSTRACT**

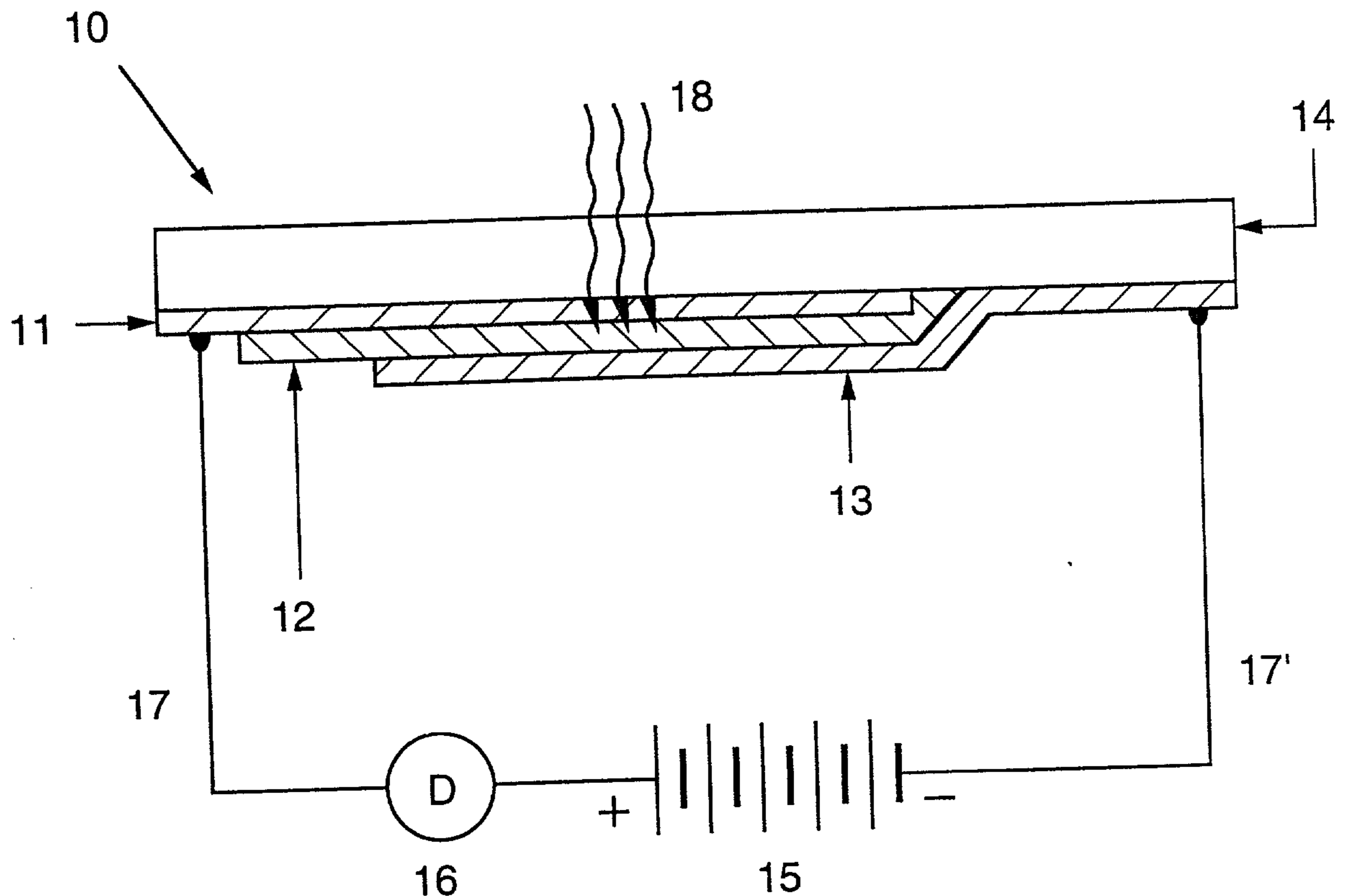
Organic photodetectors with switchable photosensitivity are achieved using organic photoactive layers in electrode/organic/electrode structures. The photosensitivity can be switched on and off by the biasing voltage across the detectors. The photocurrent can be probed with a read-out circuit in the loop. These photodetectors can be arranged in linear arrays or in two-dimensional matrices that function as high performance, linear or two-dimensional image sensors. These image sensors can achieve fill color or selected color detection capability.

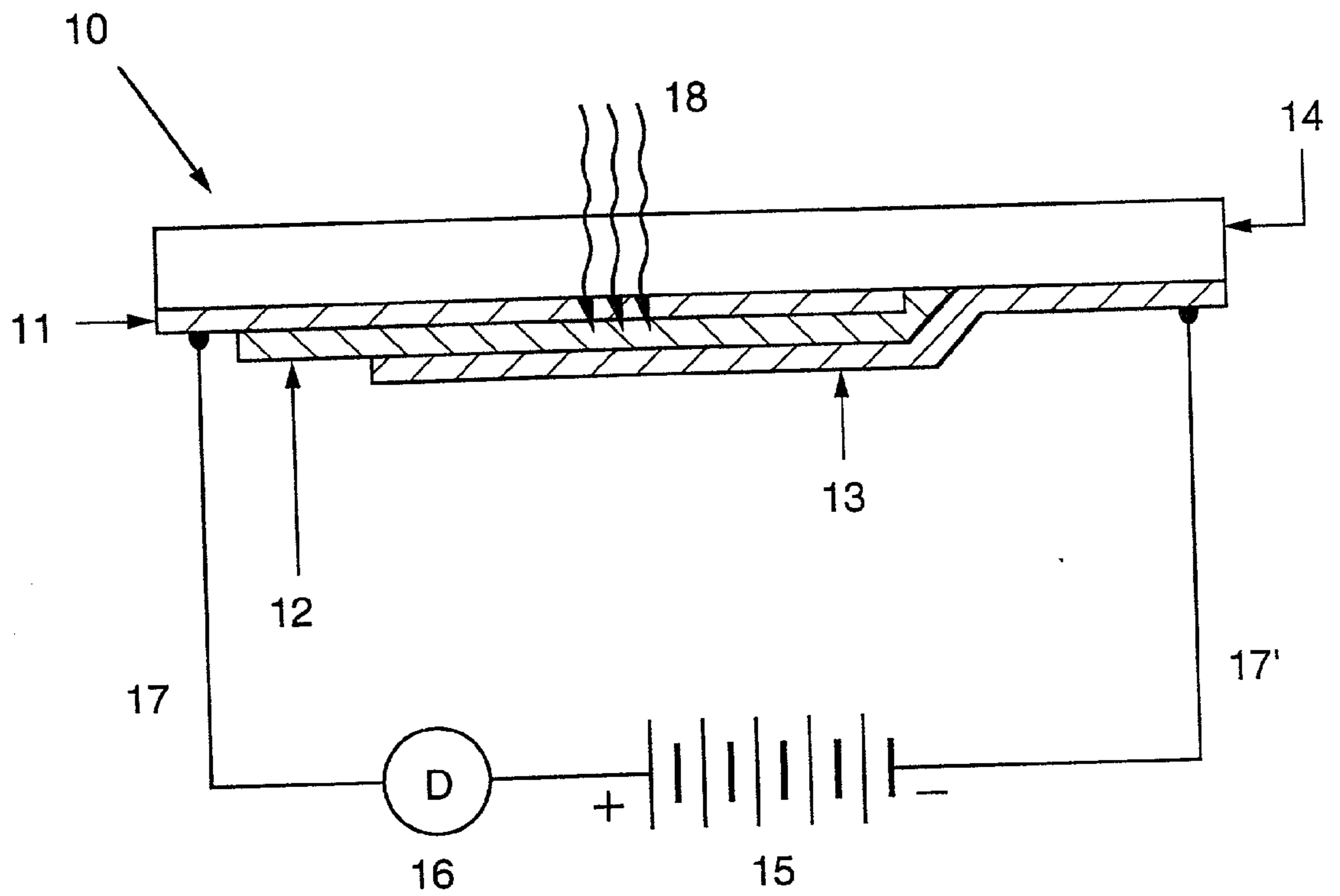
(21) Appl. No.: **09/930,771**

(22) Filed: **Aug. 16, 2001**

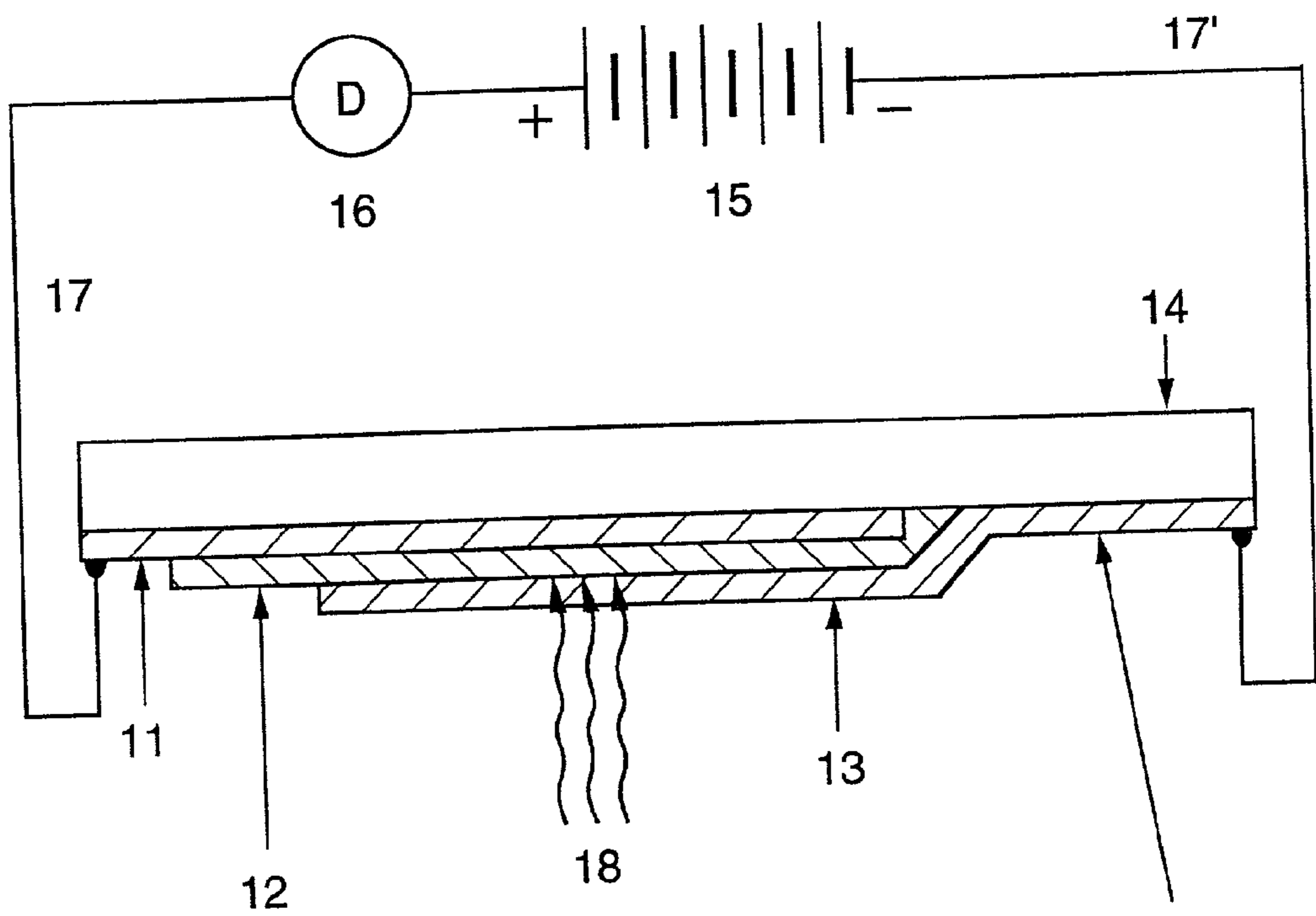
**Related U.S. Application Data**

(60) Division of application No. 09/241,660, filed on Feb. 2, 1999, now Pat. No. 6,303,943, which is a non-

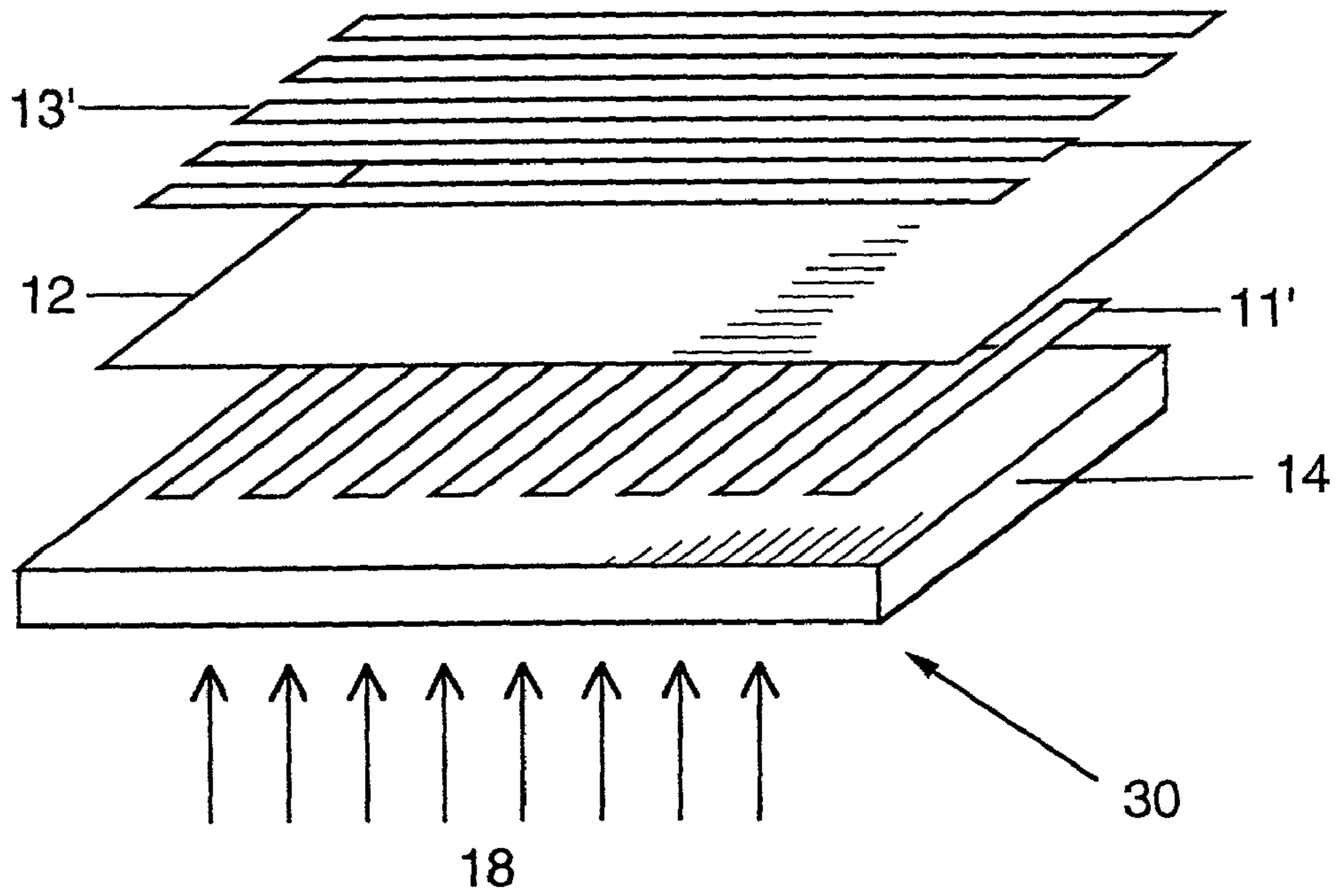




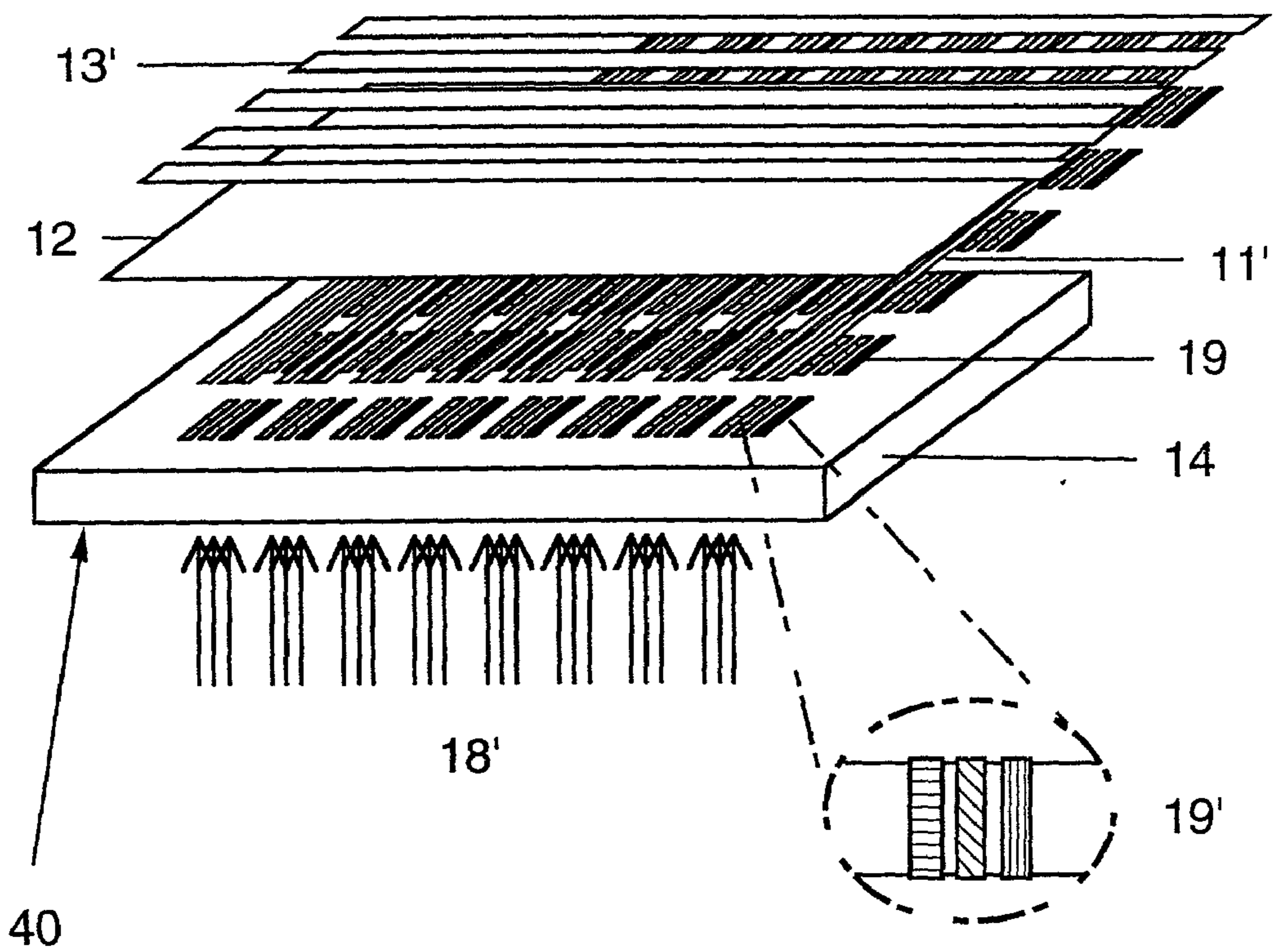
**FIG. 1**



**FIG. 2**



**FIG. 3**



**FIG. 4**

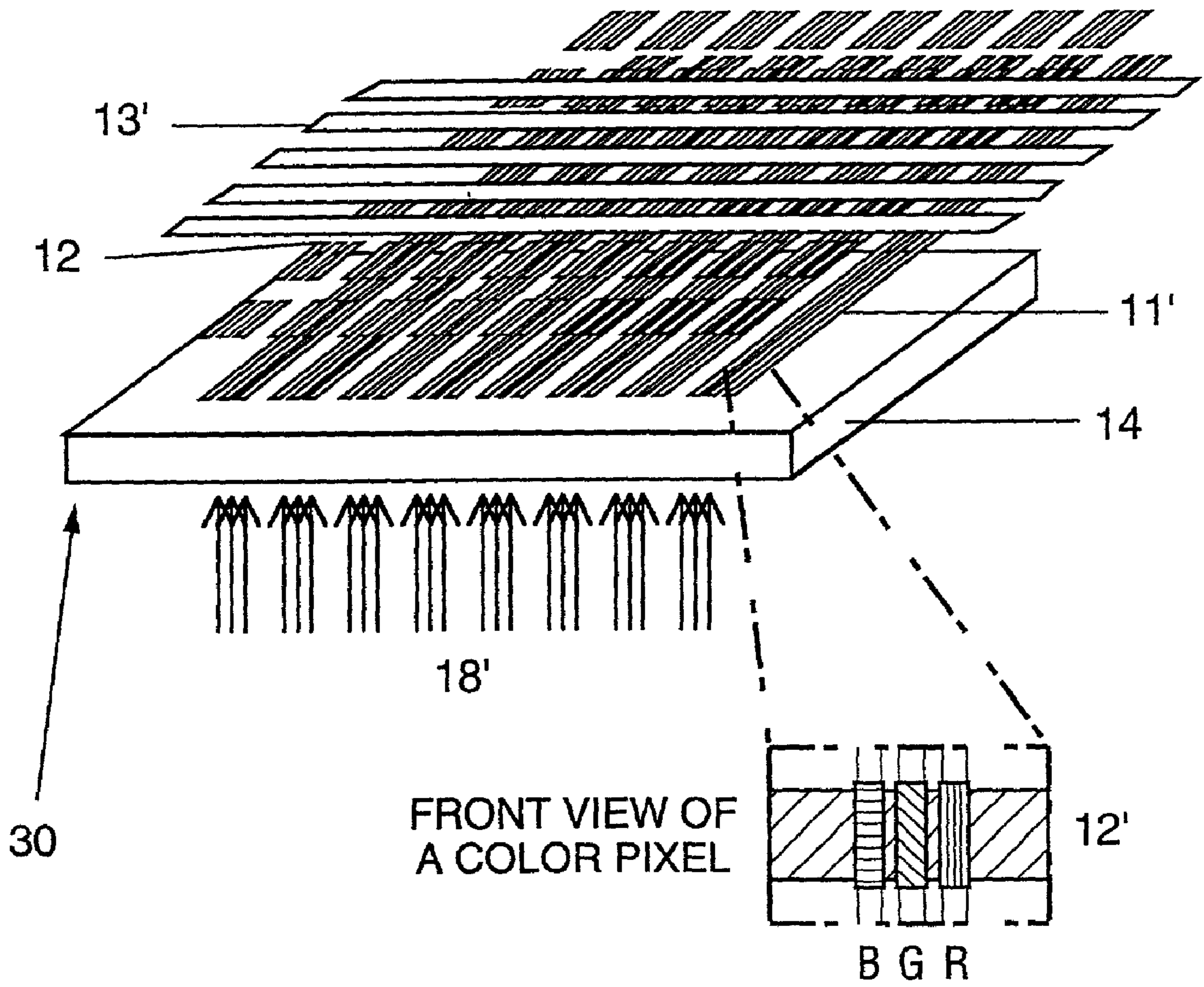
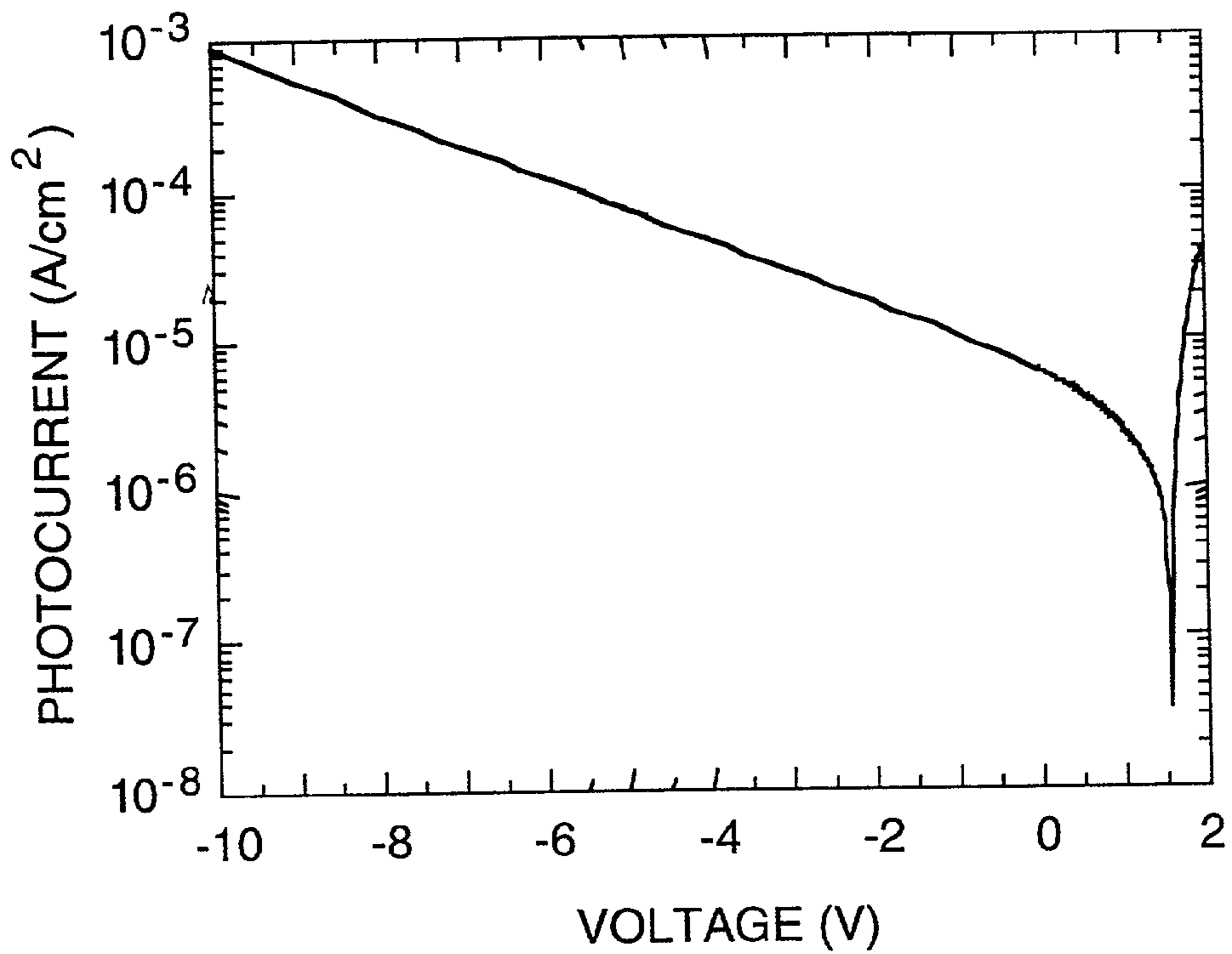
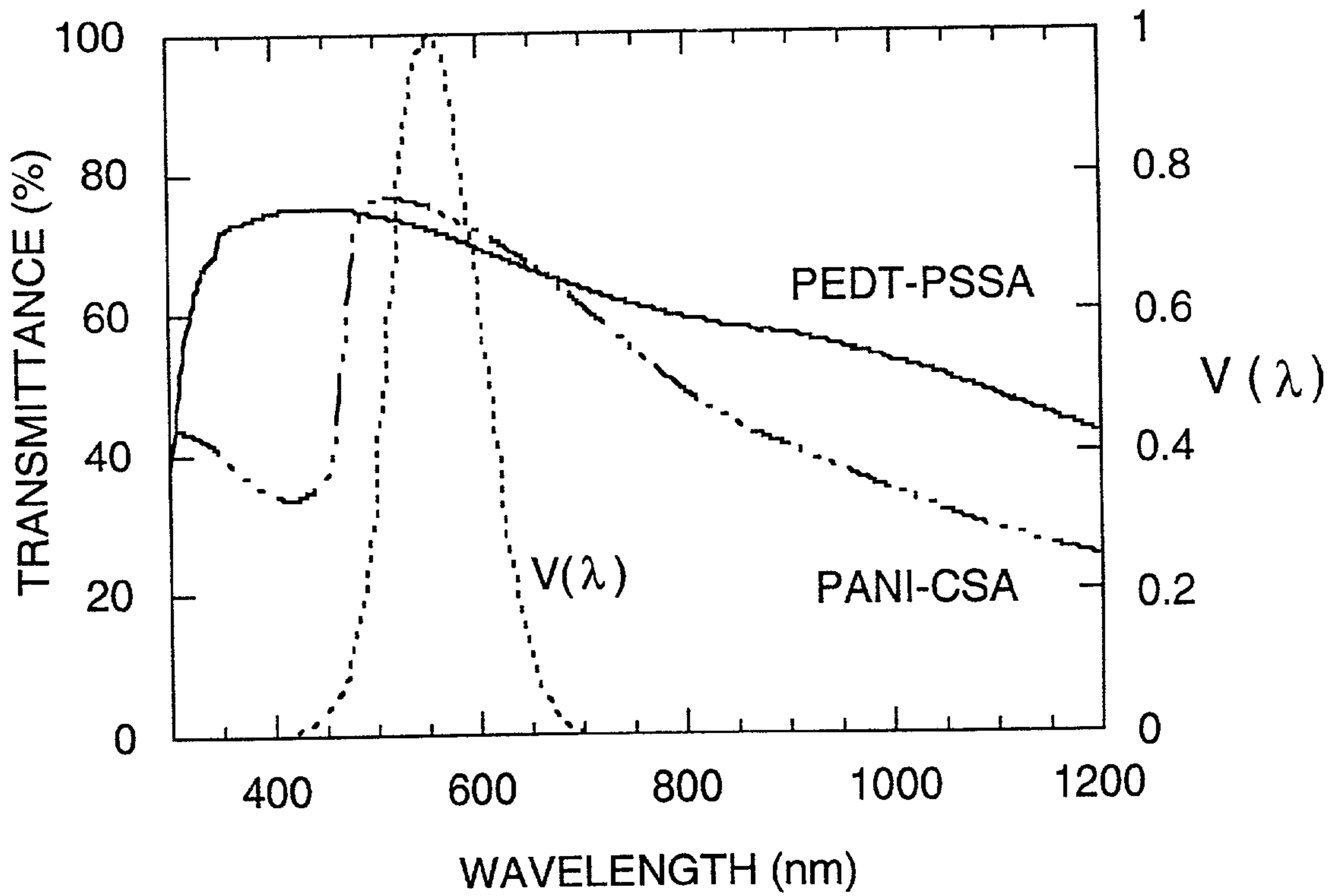


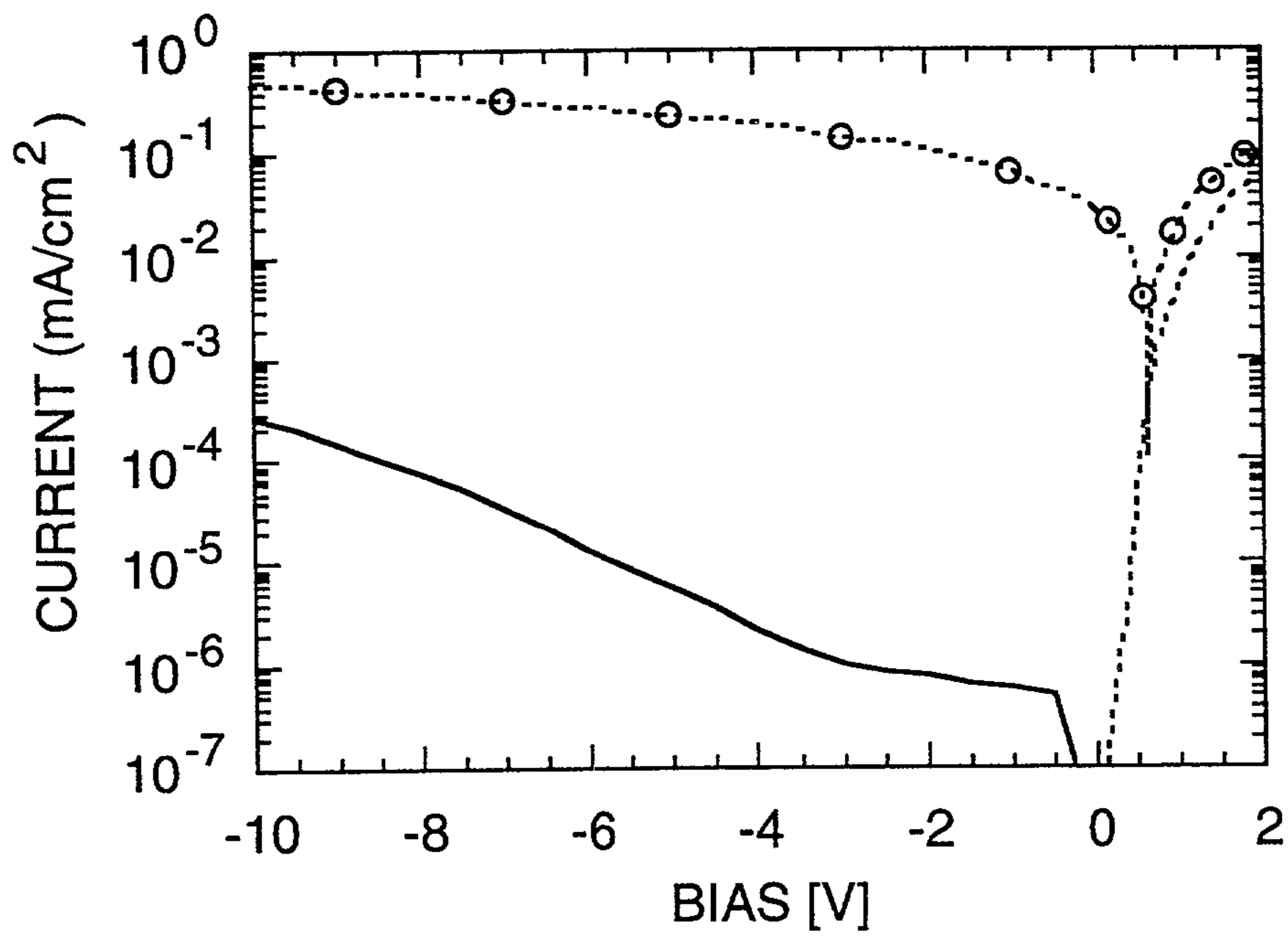
FIG. 5



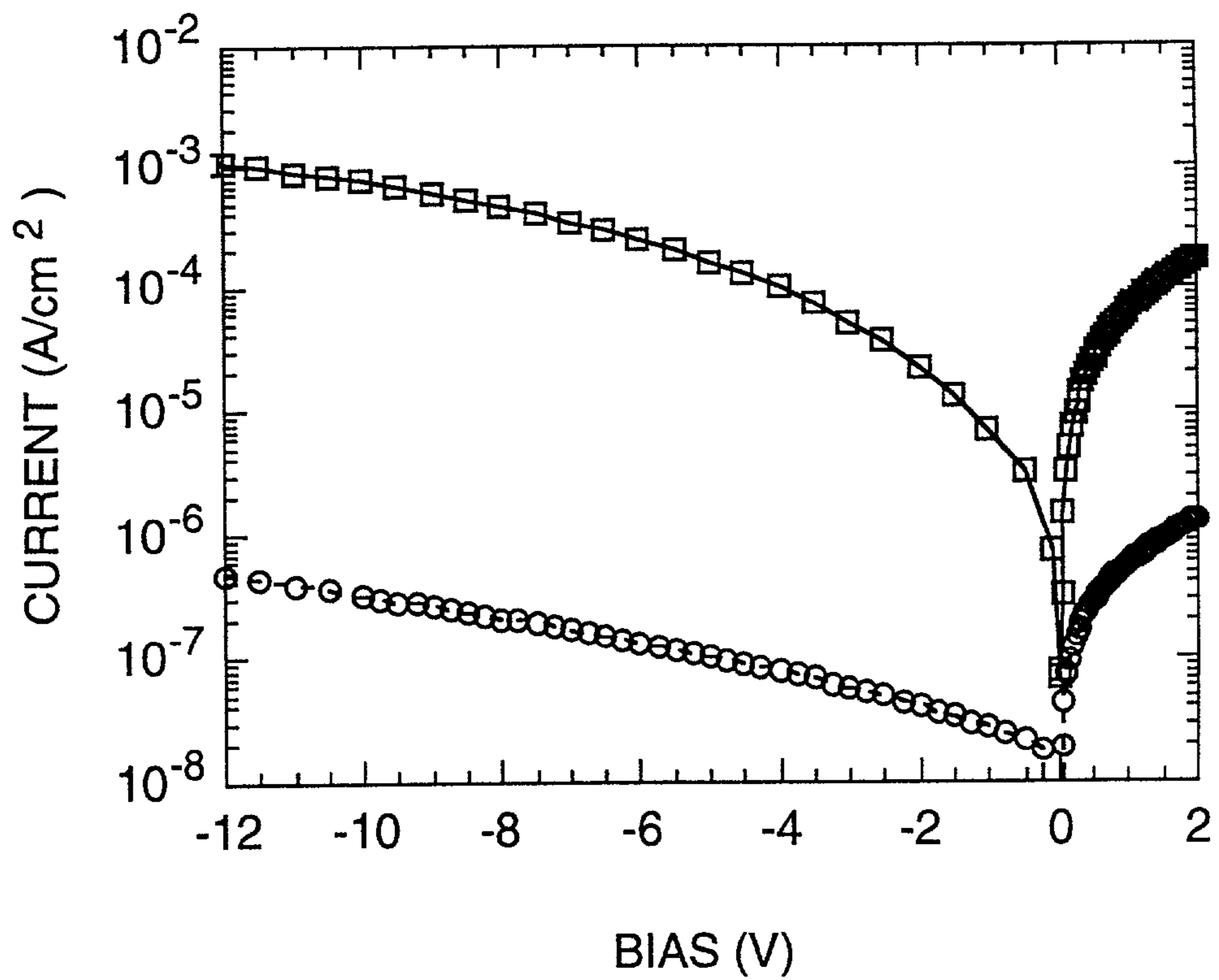
**FIG. 6**



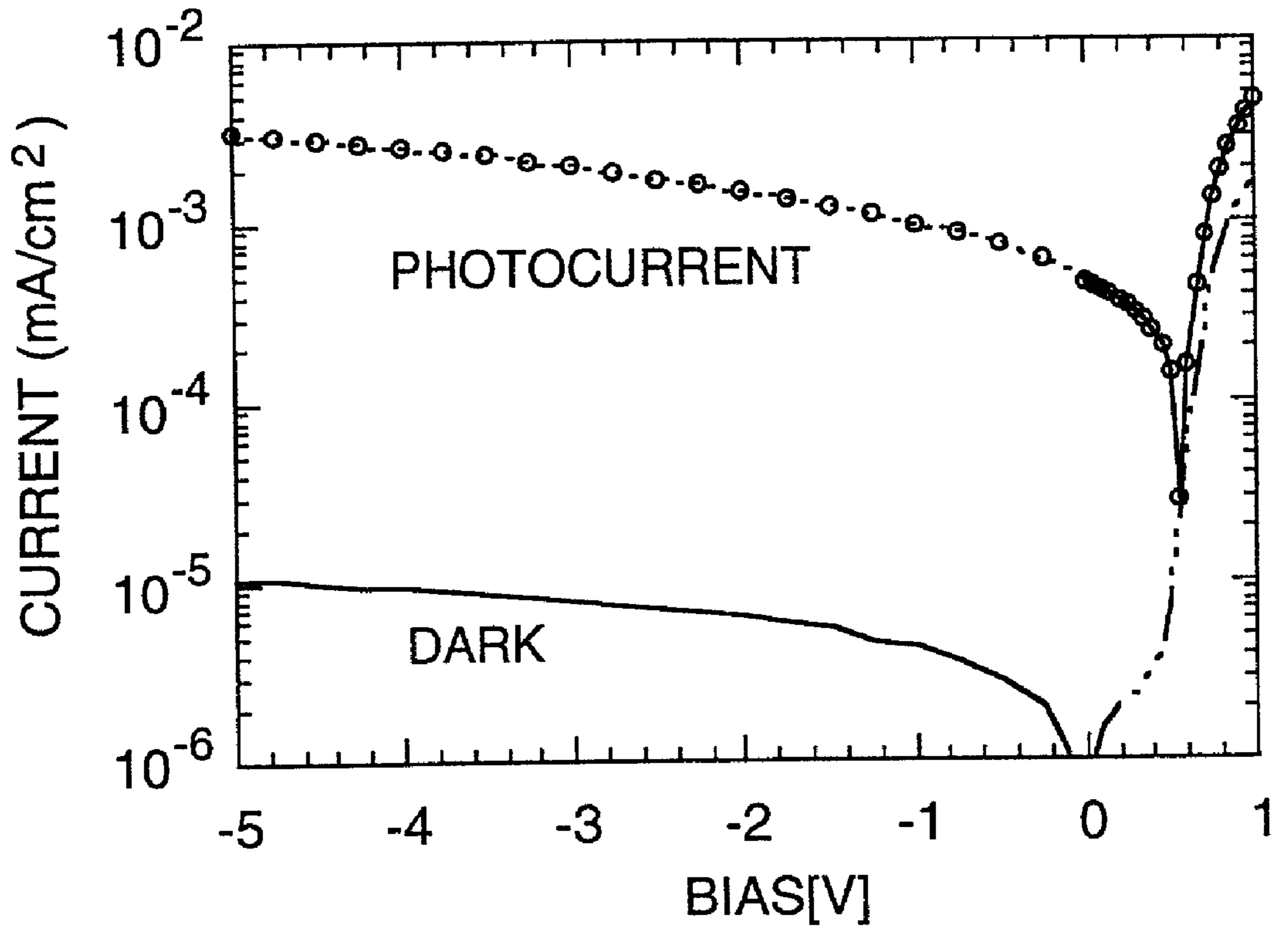
**FIG. 7**



**FIG. 8**



**FIG. 9**



**FIG. 10**

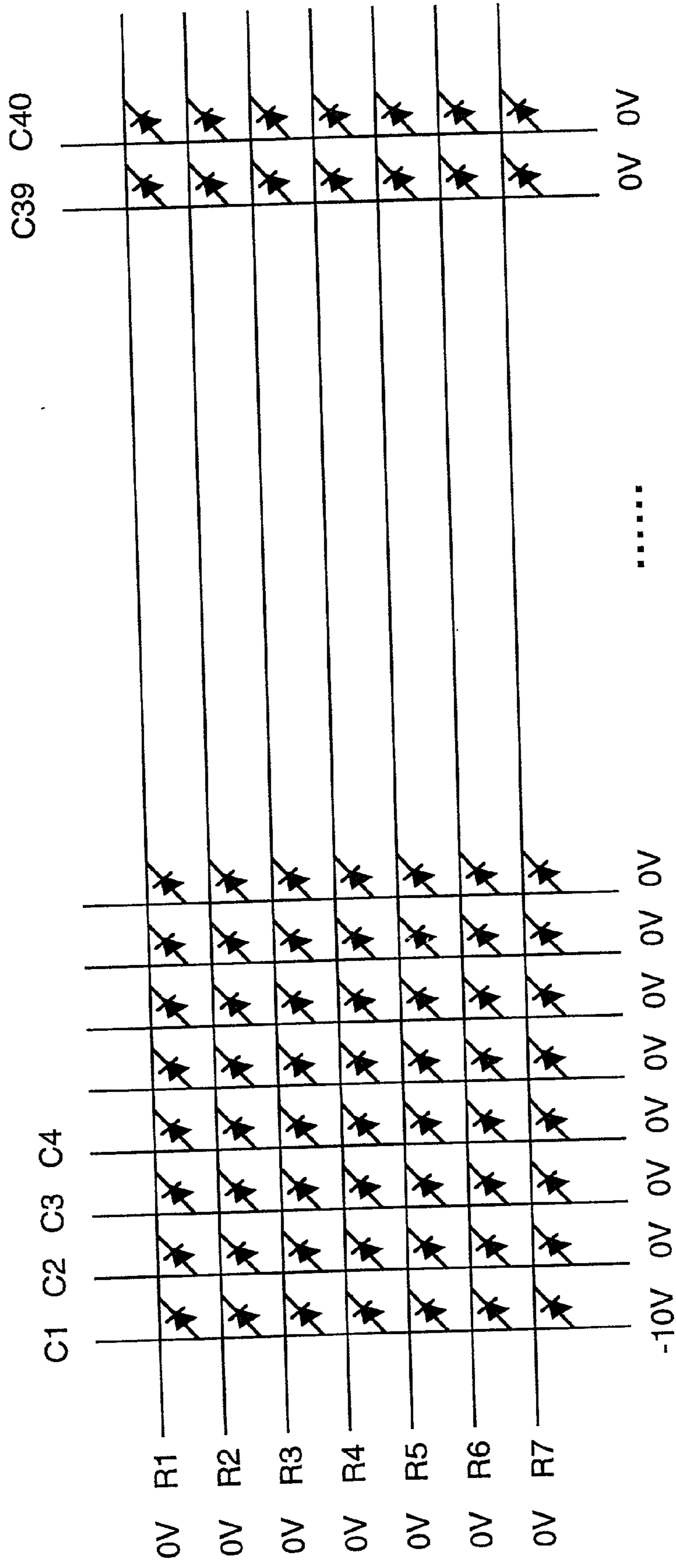
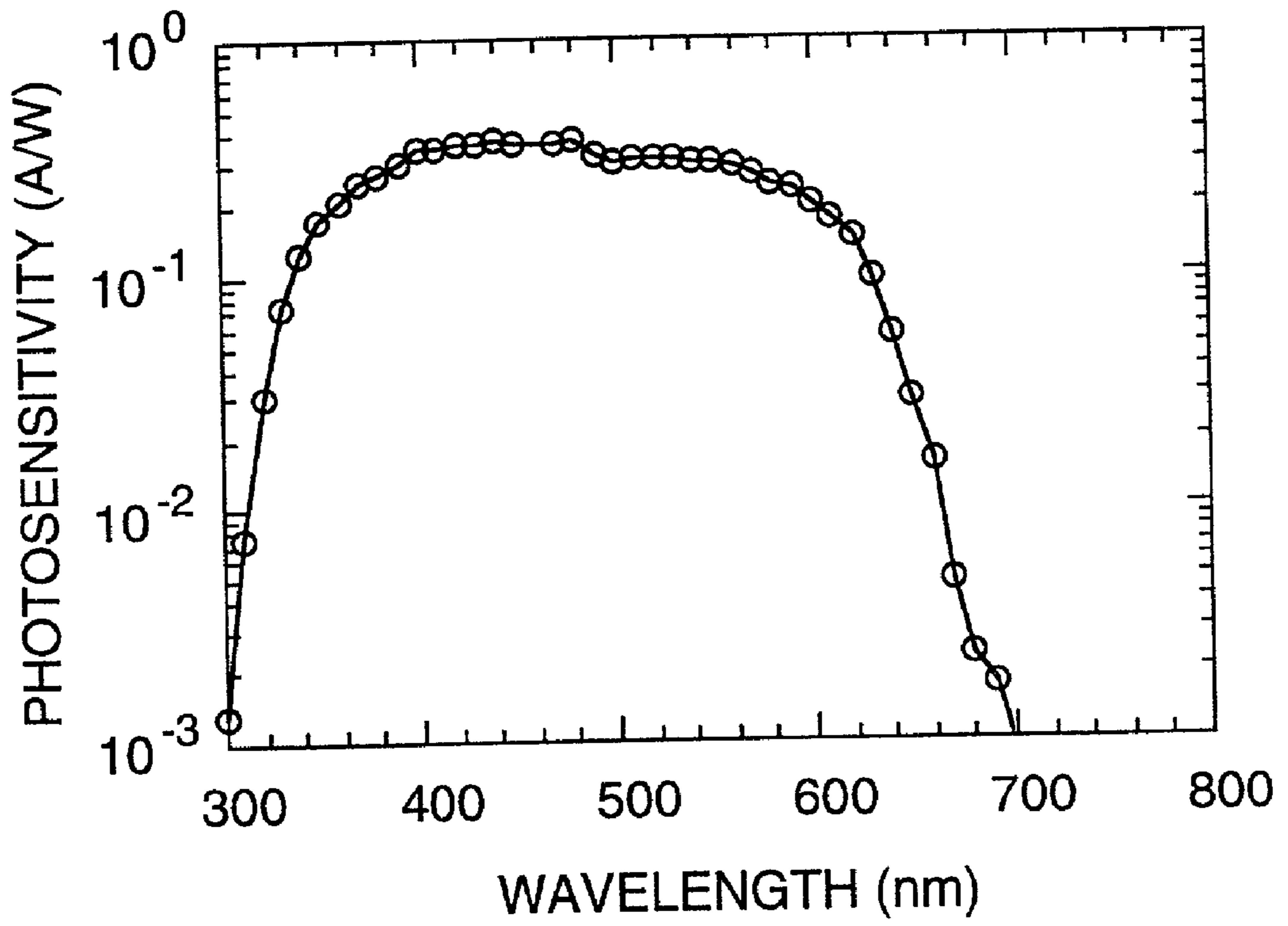
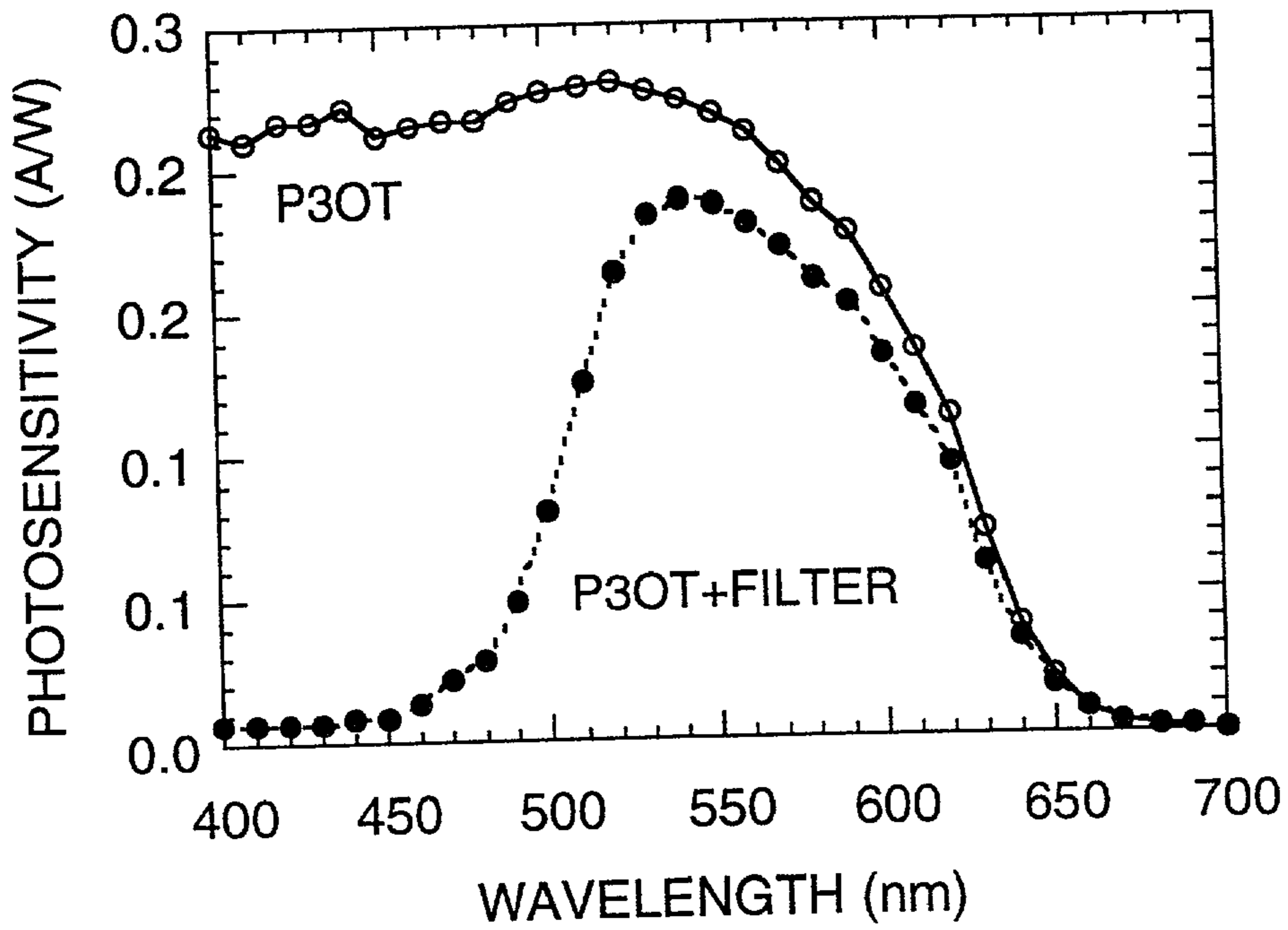


FIG. 11

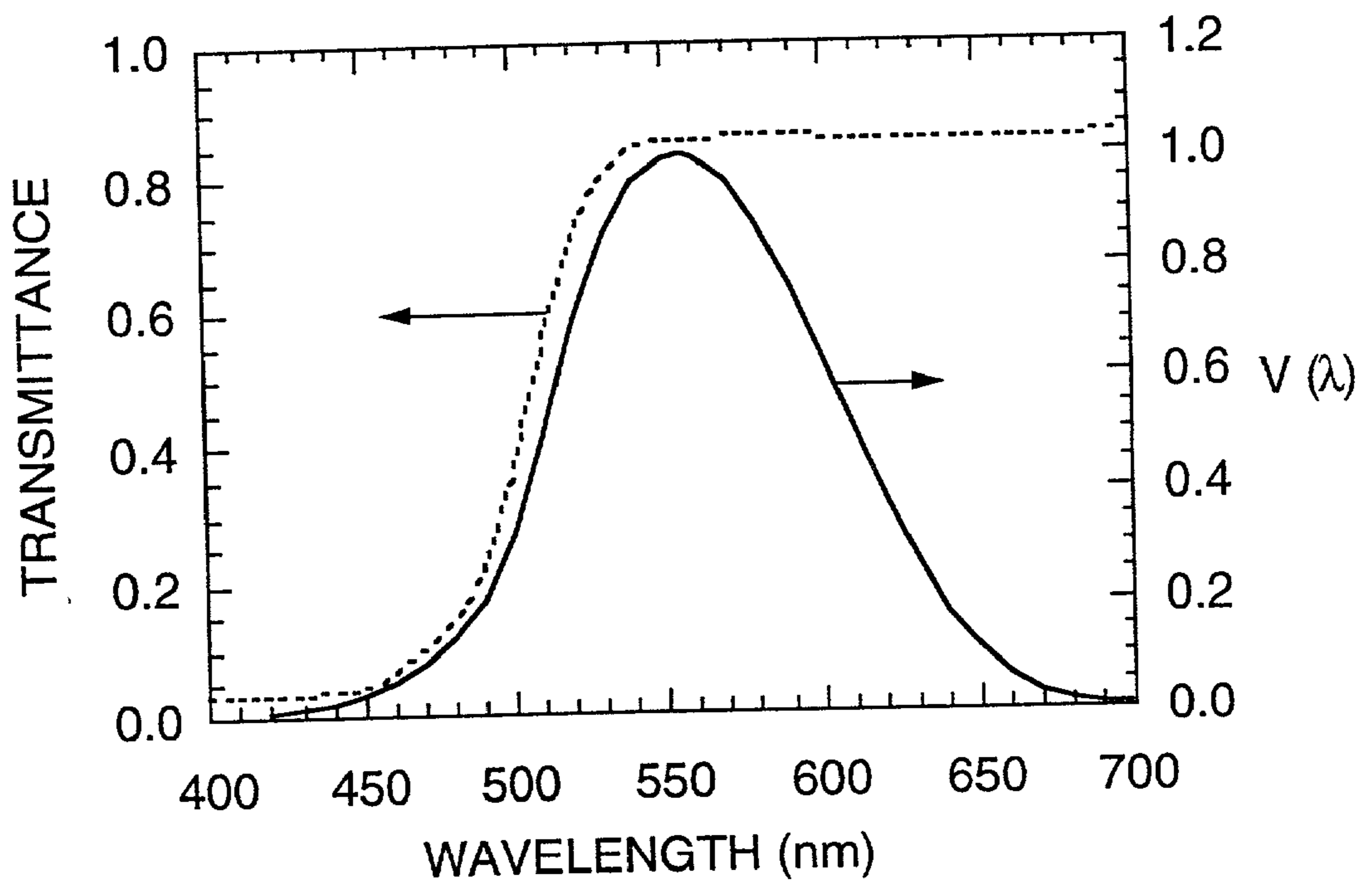




**FIG. 12**



**FIG. 13A**



**FIG. 13B**

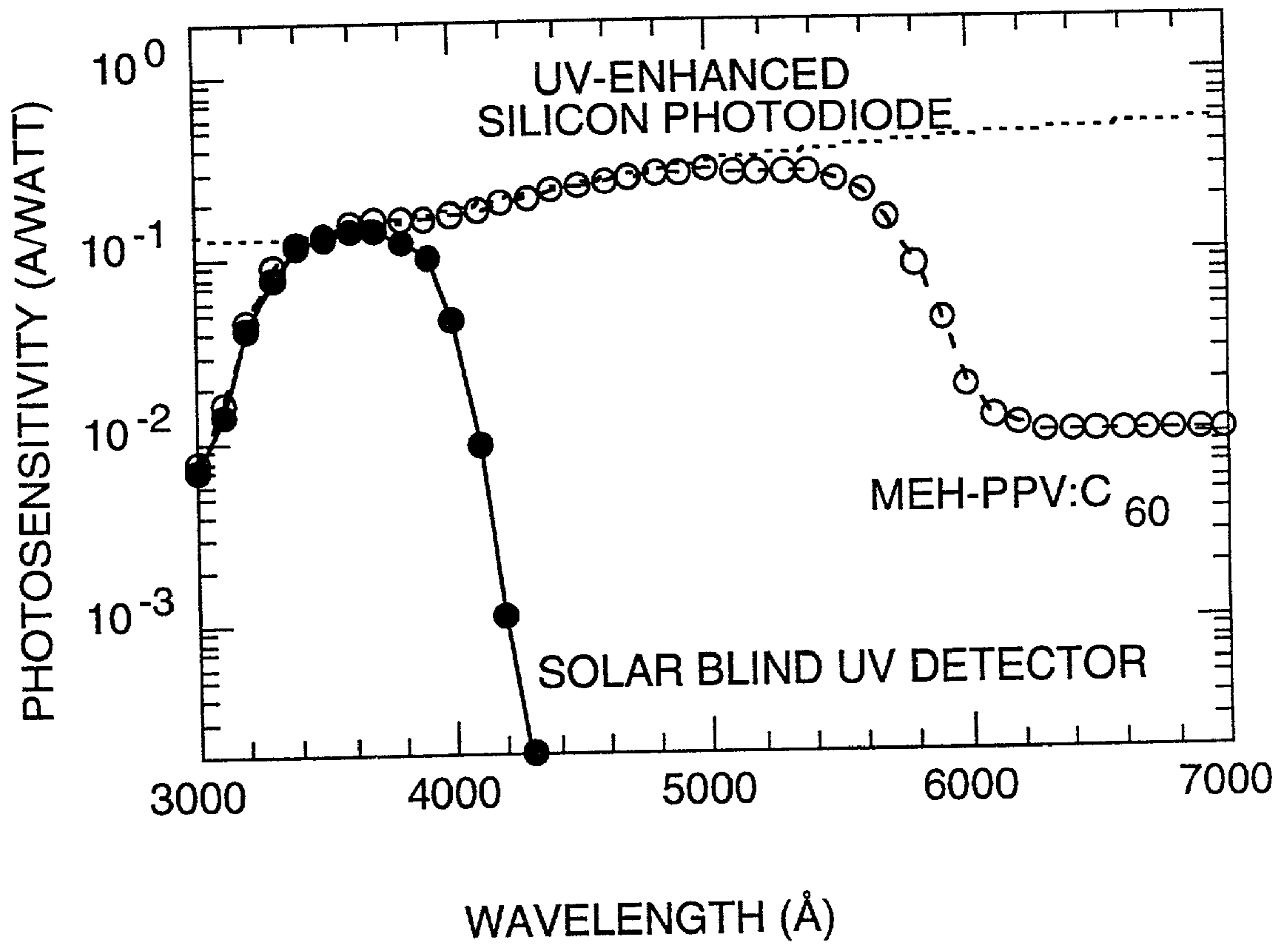


FIG. 14

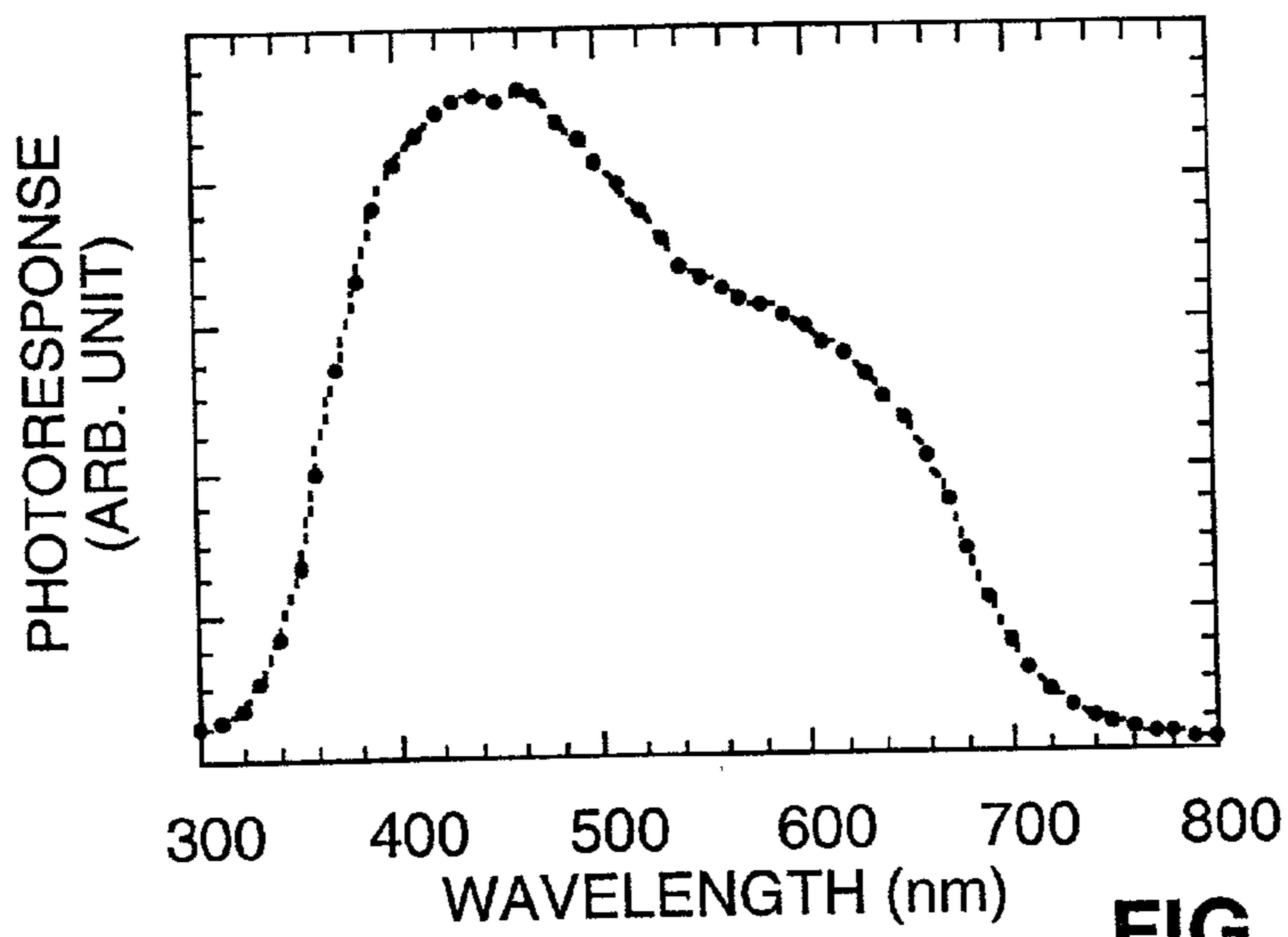


FIG. 15A

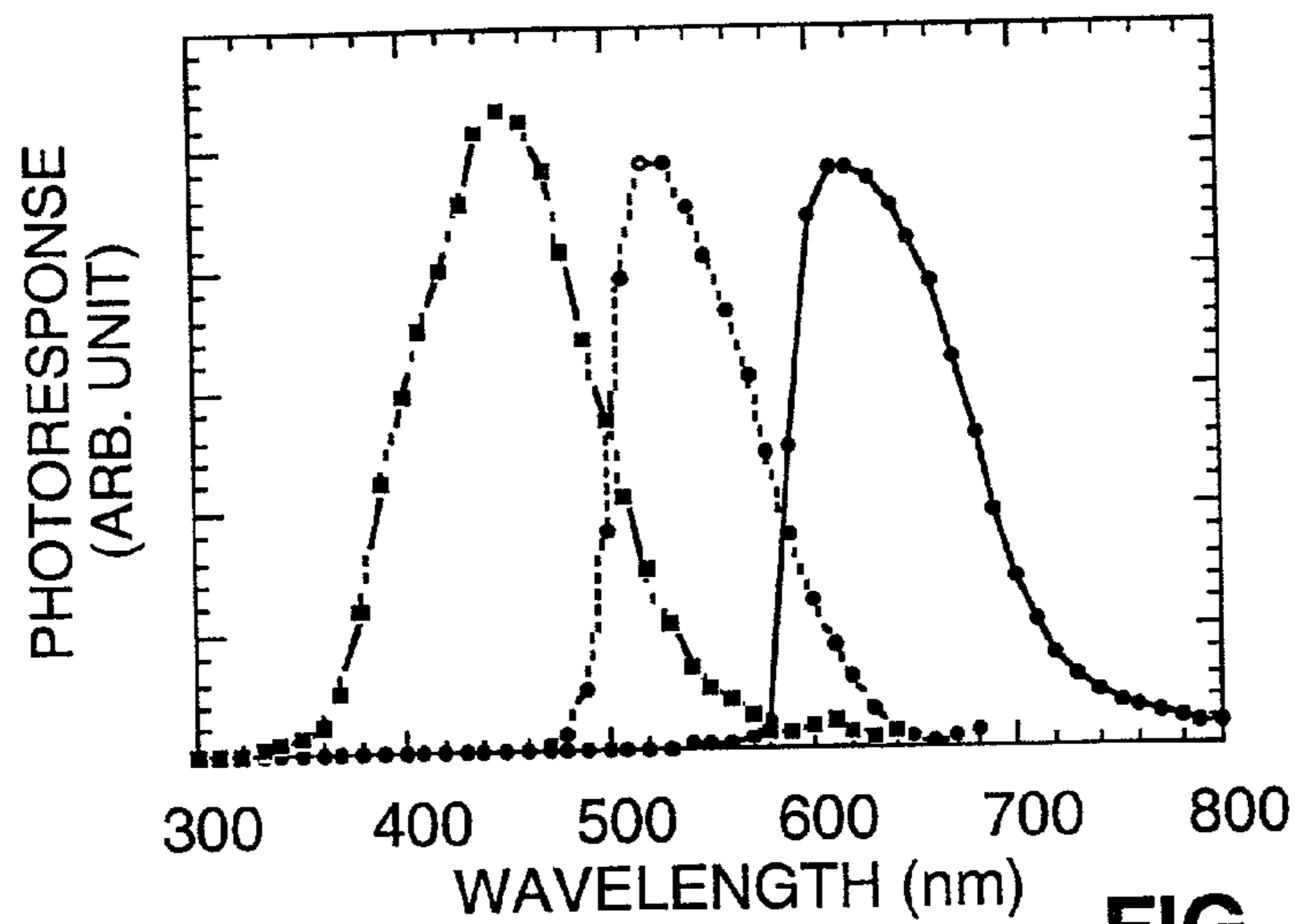


FIG. 15B

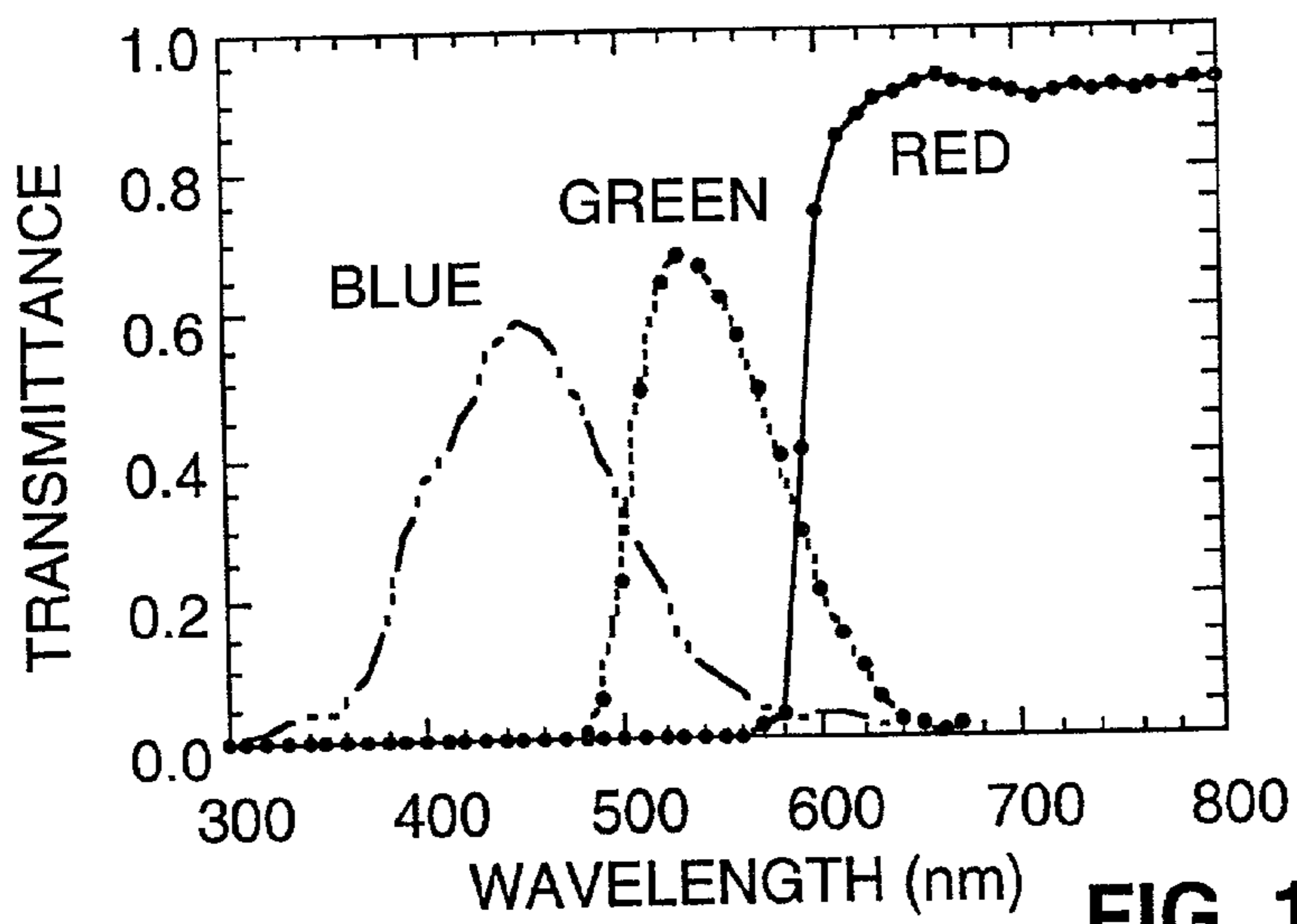
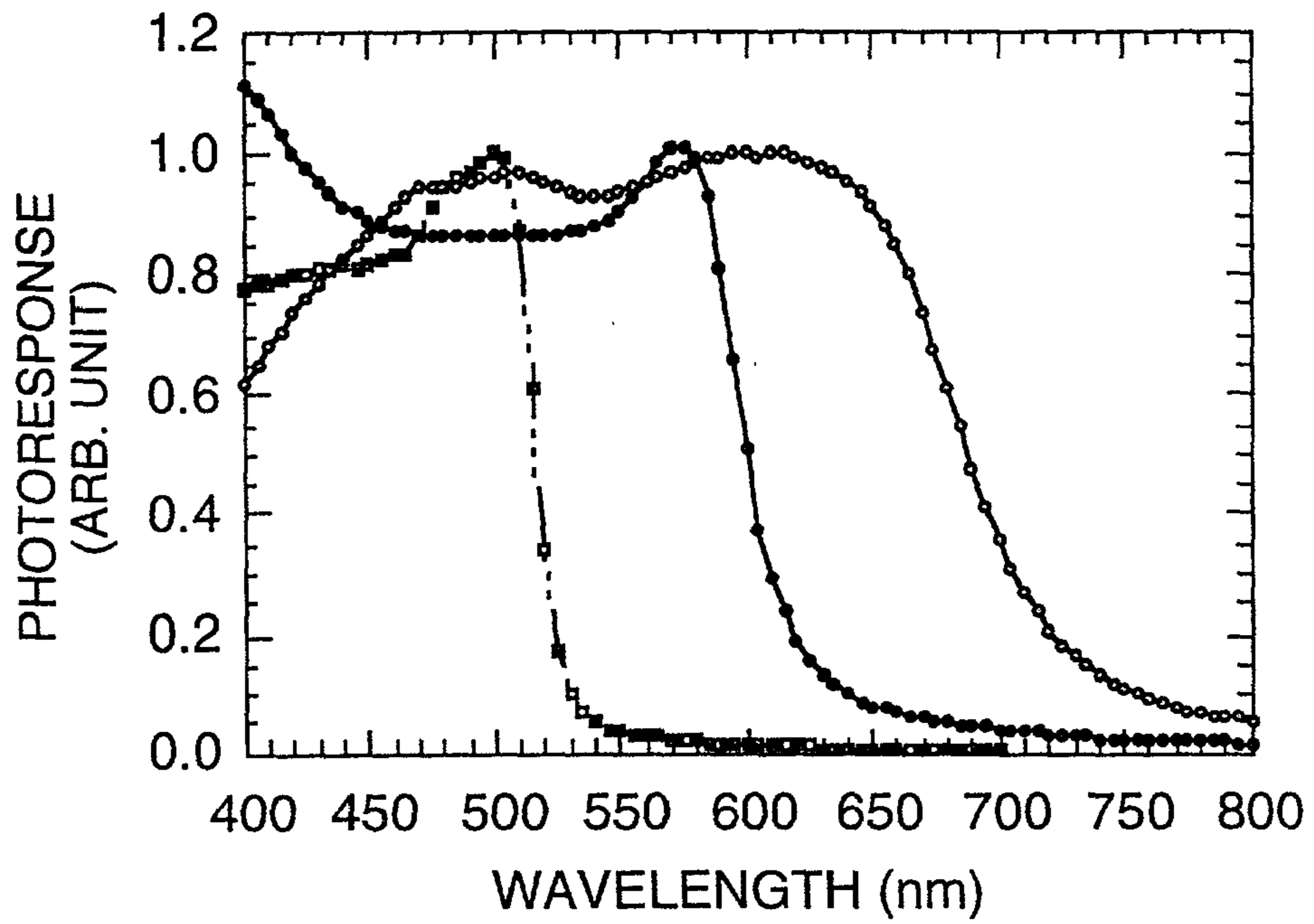
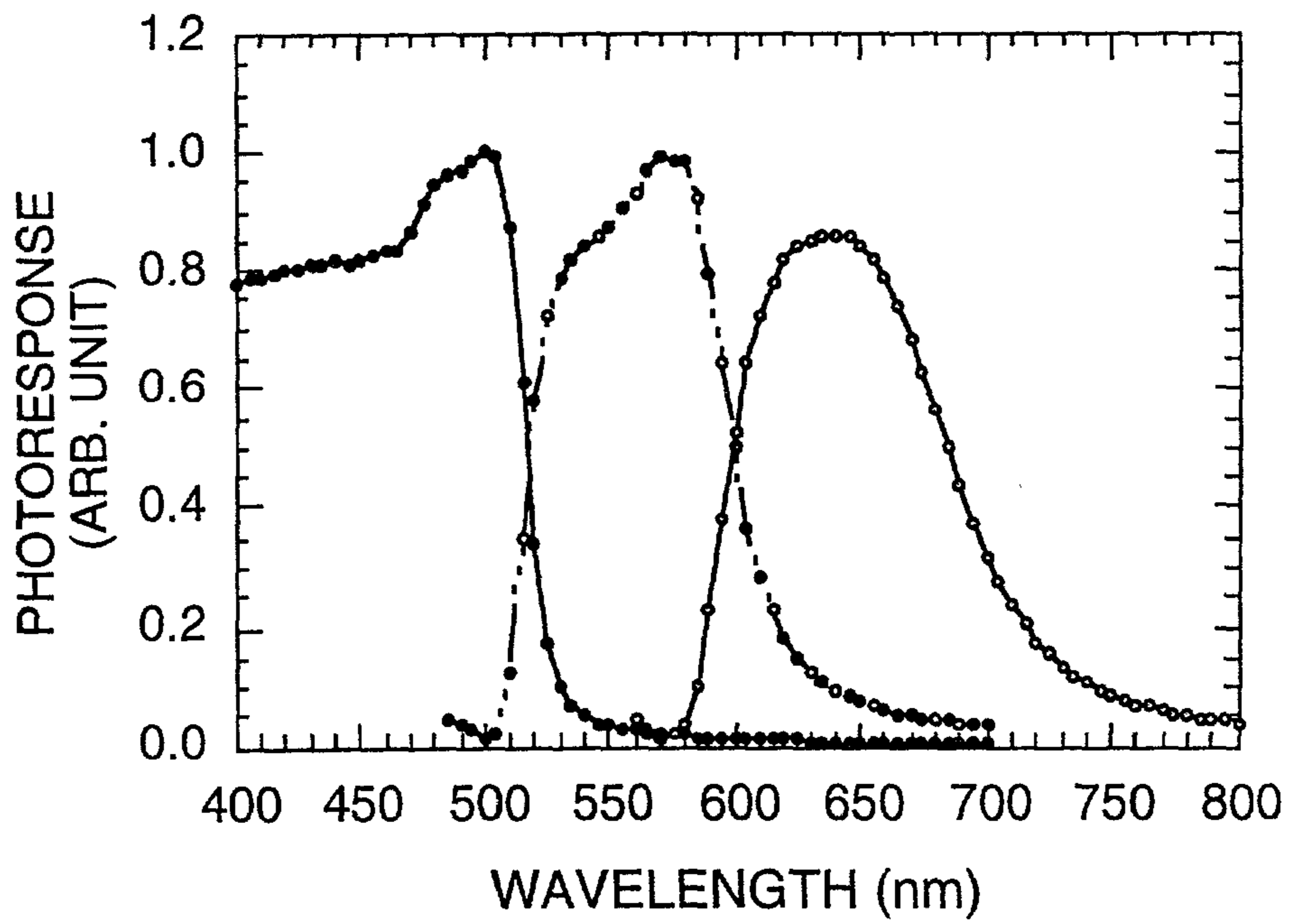


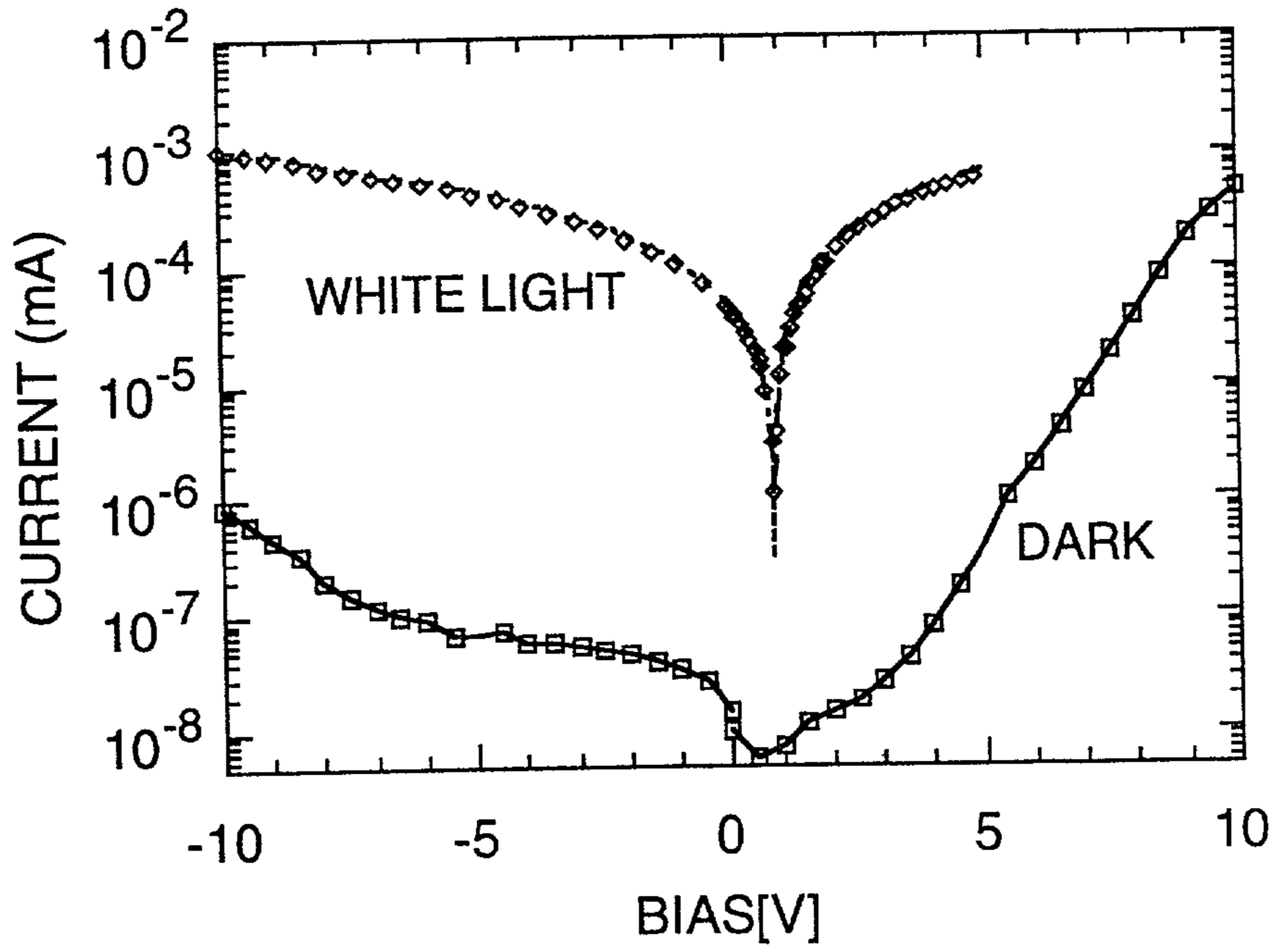
FIG. 15C



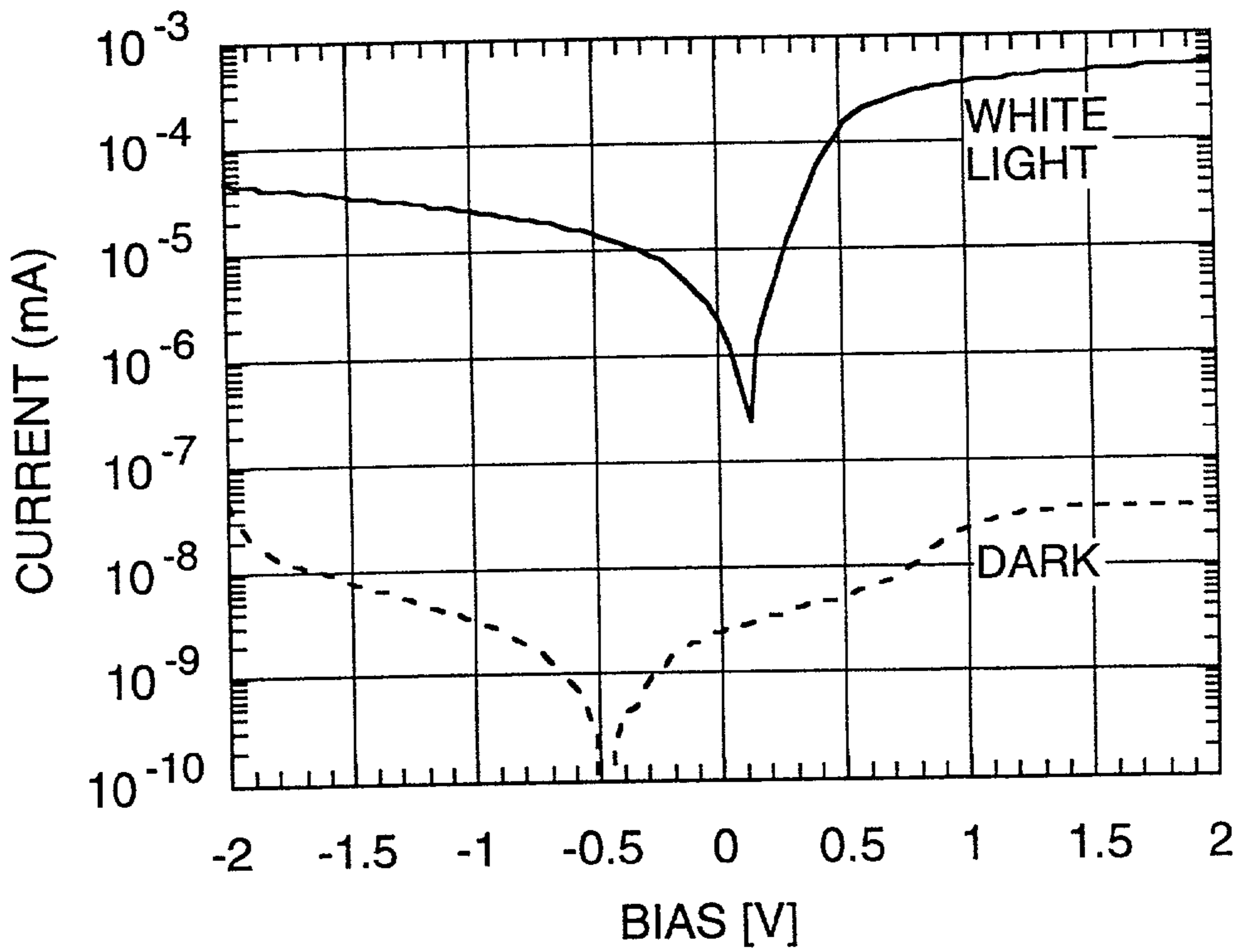
**FIG. 16A**



**FIG. 16B**



**FIG. 17**



**FIG. 18**

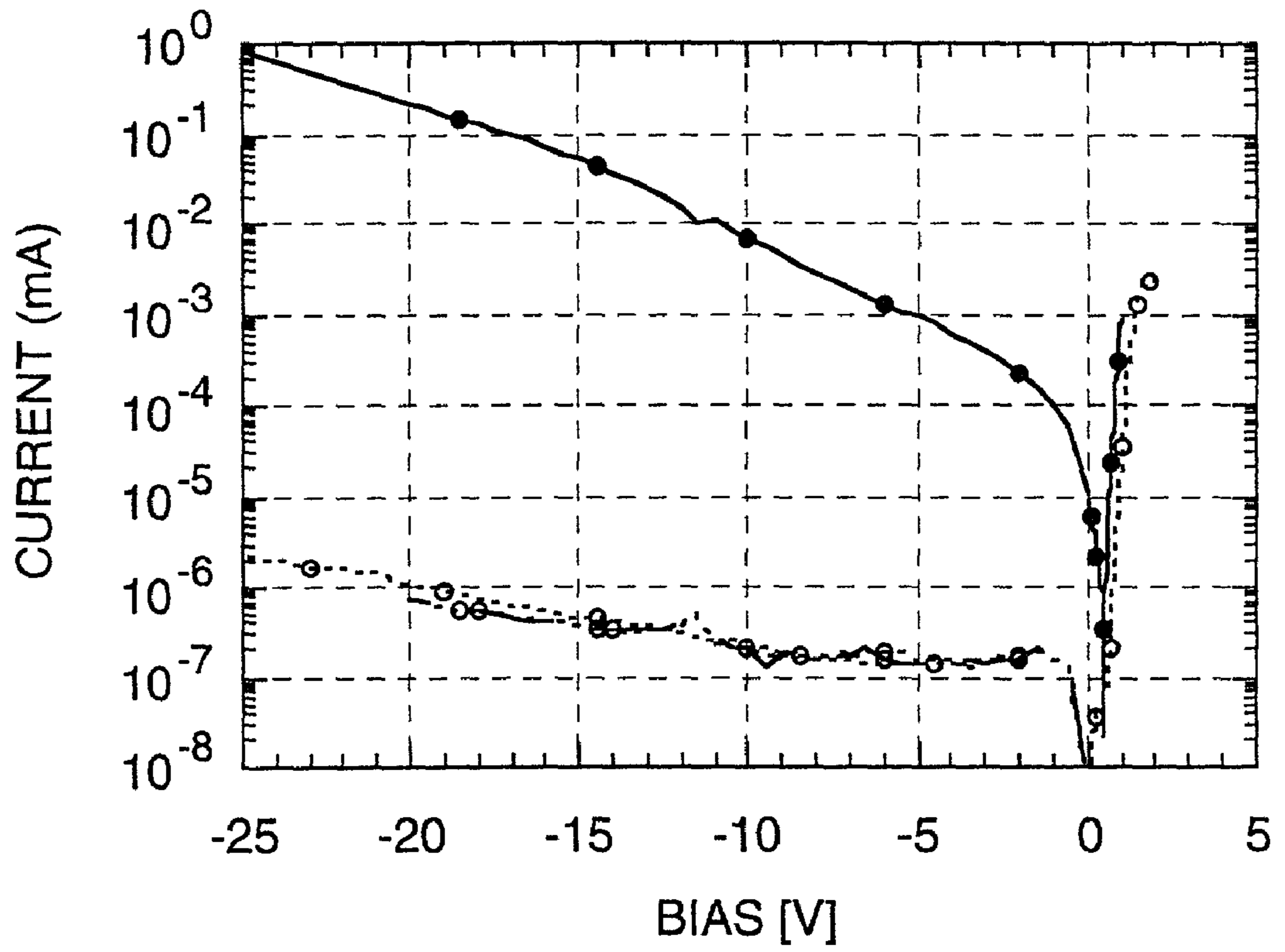


FIG. 19

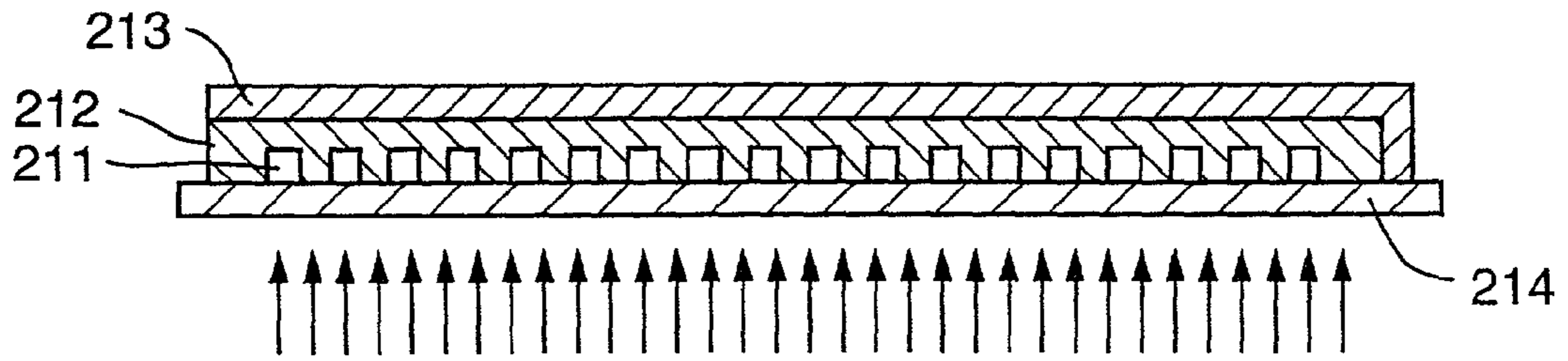


FIG. 20A

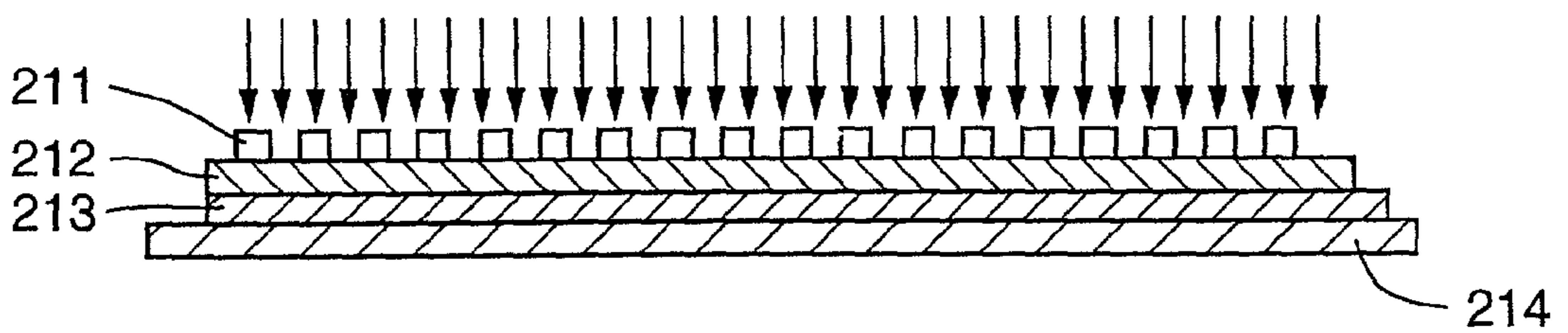


FIG. 20B

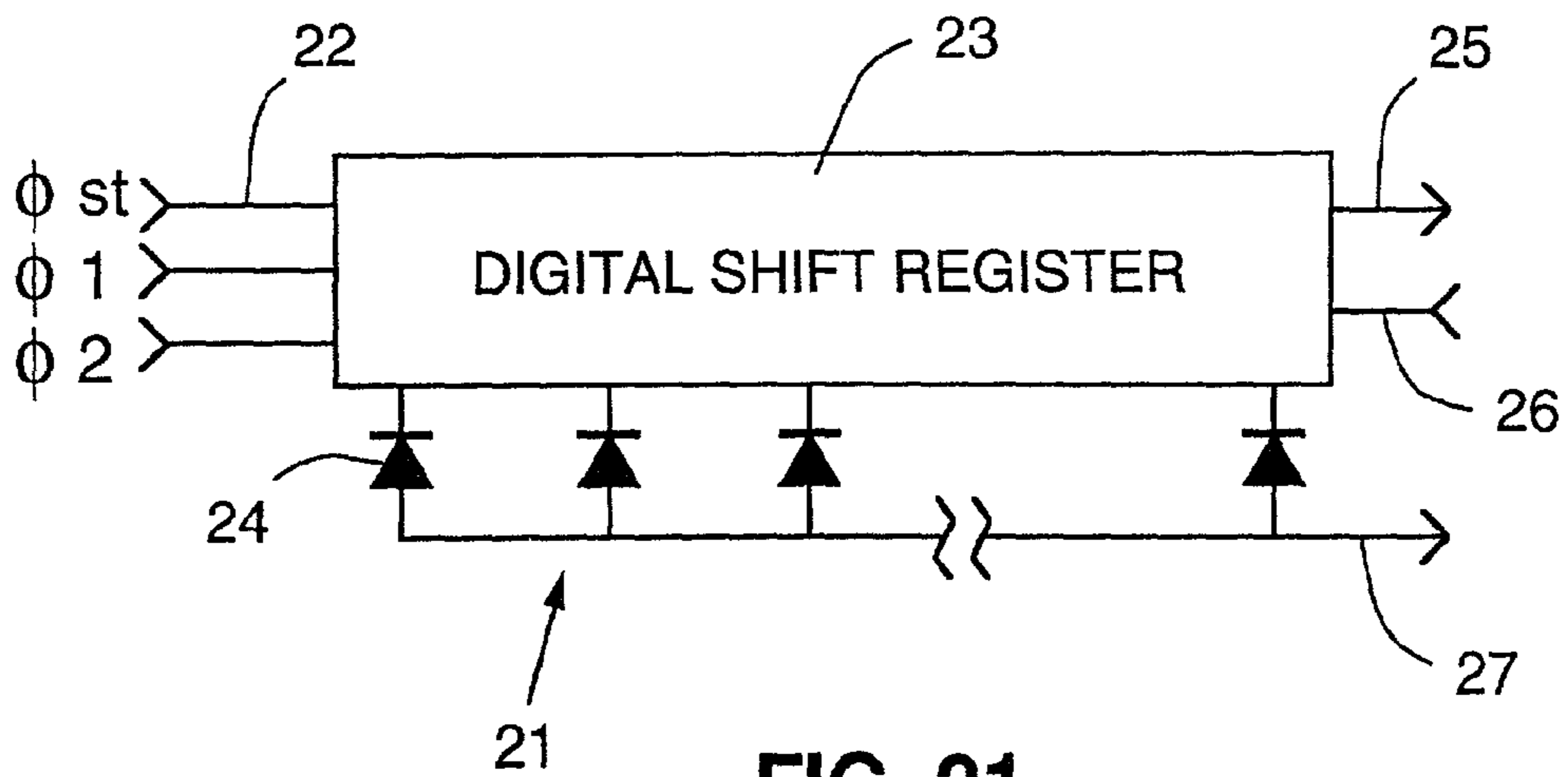
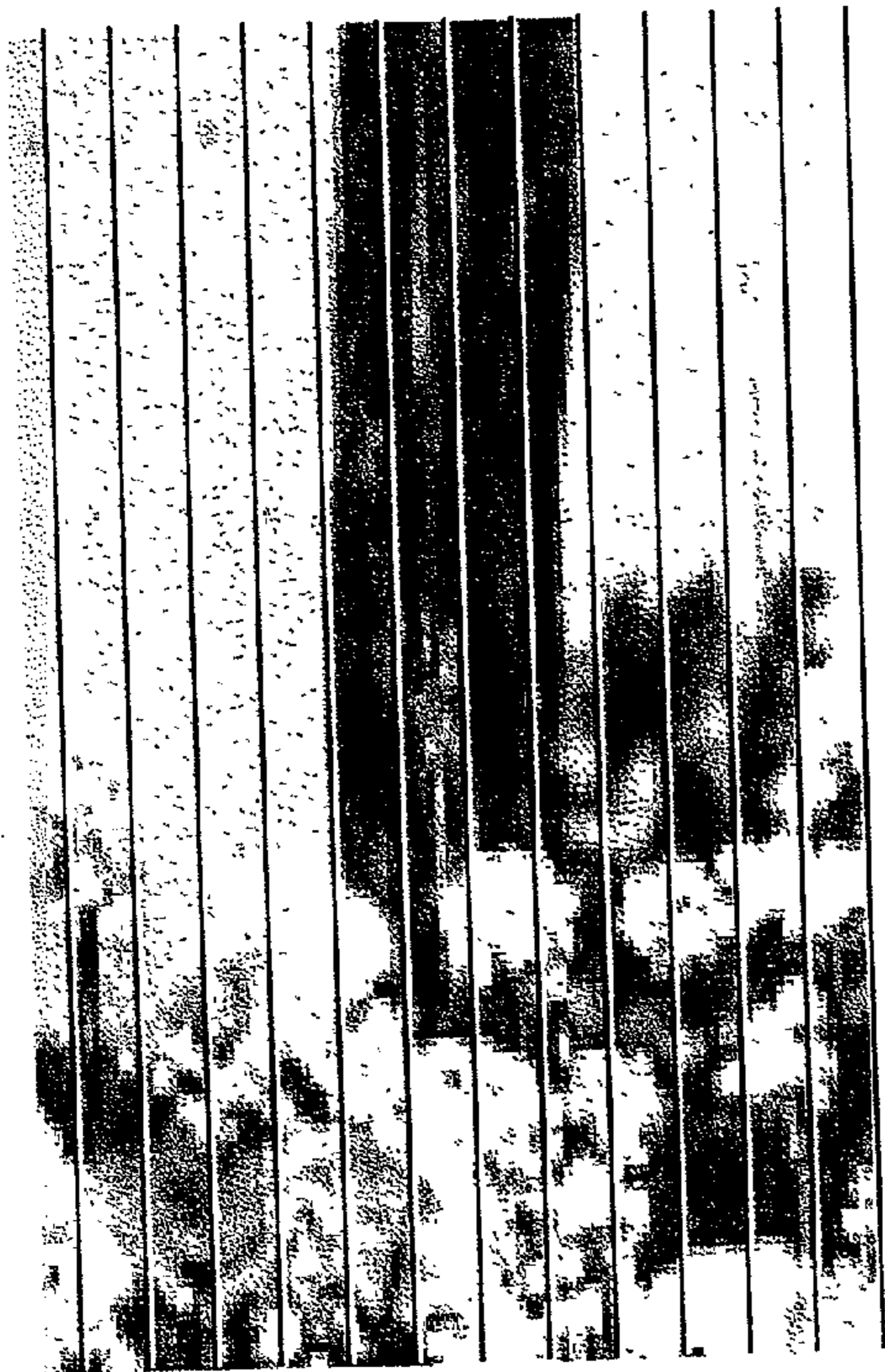
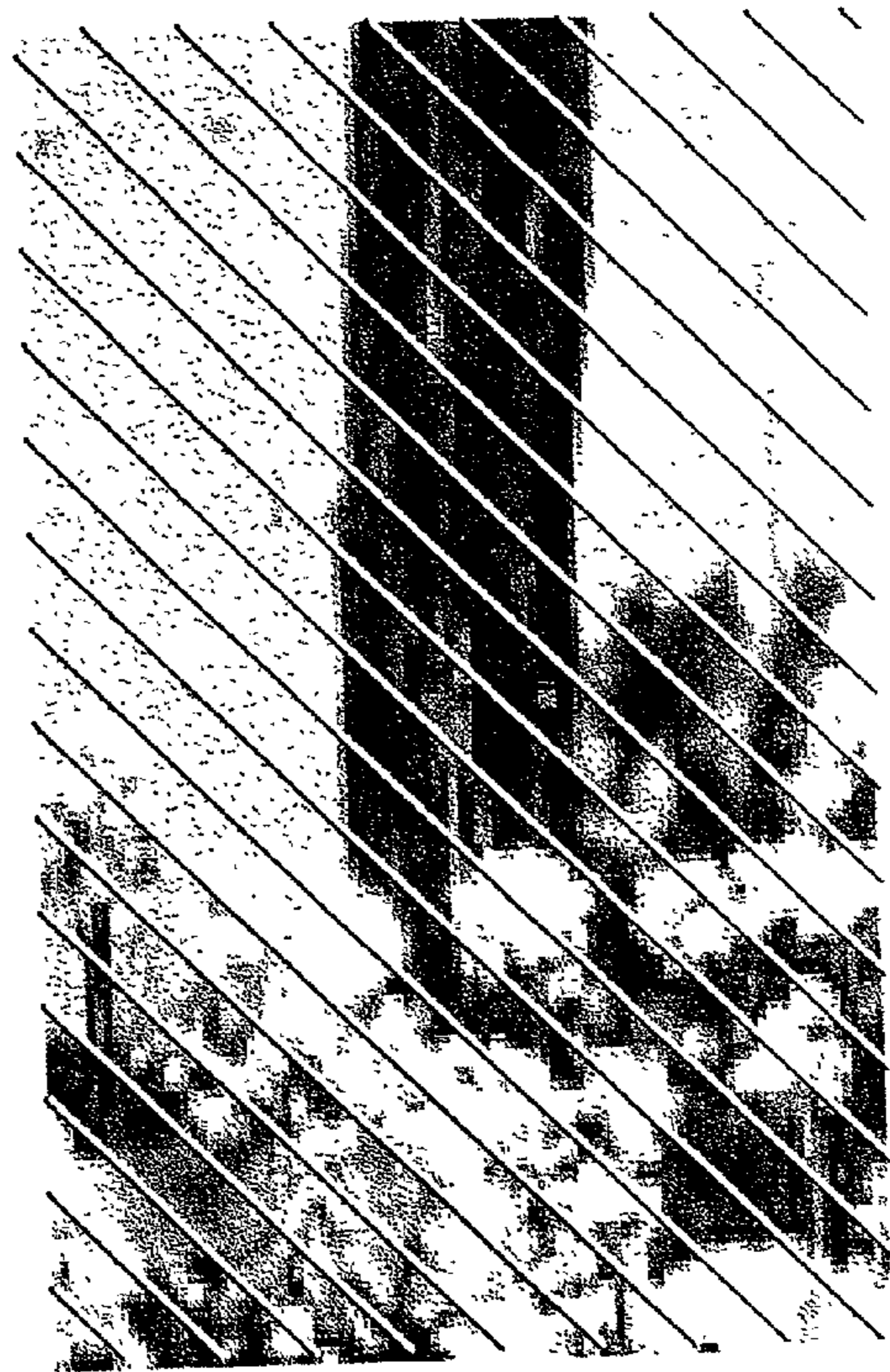


FIG. 21

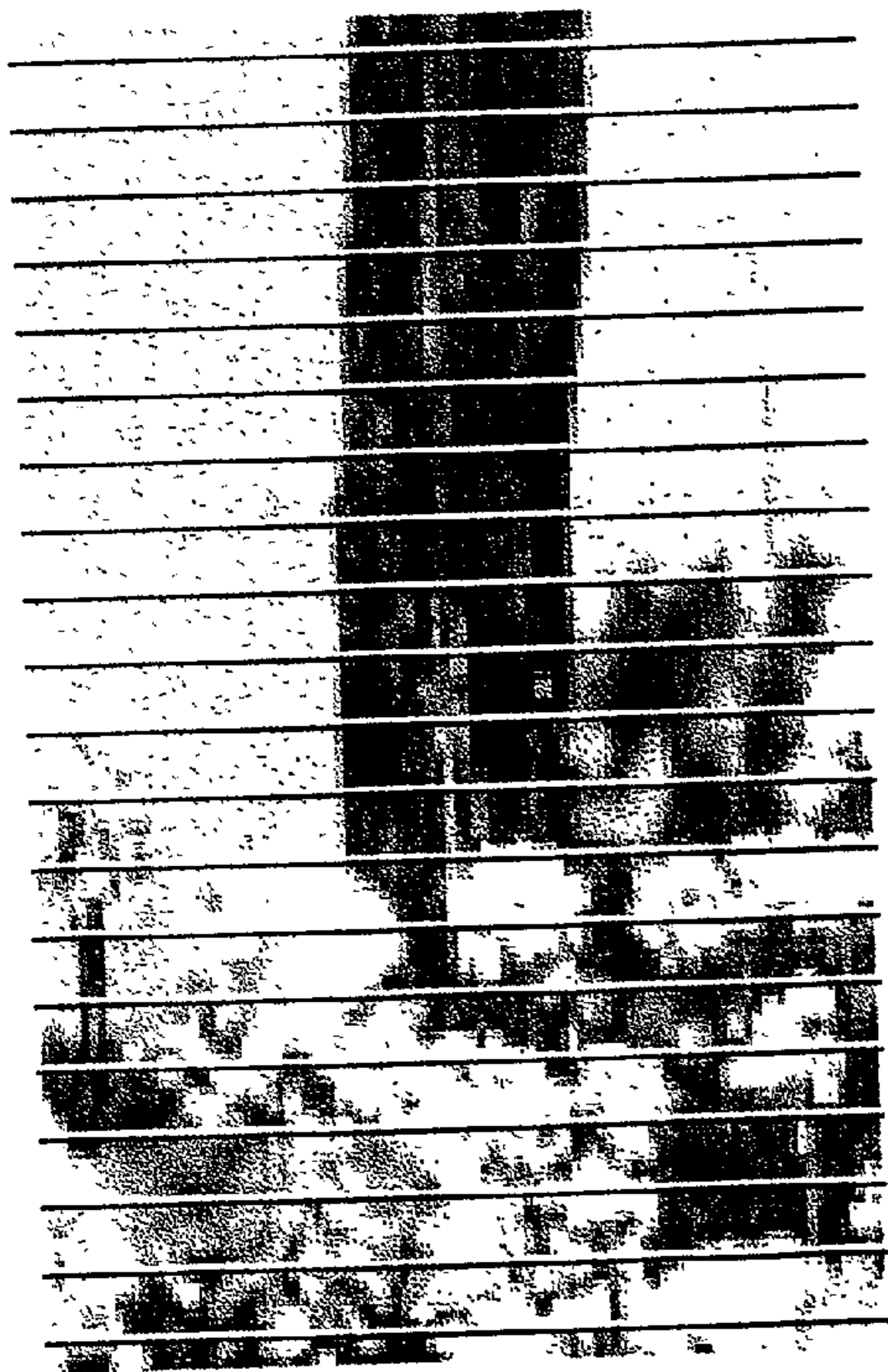




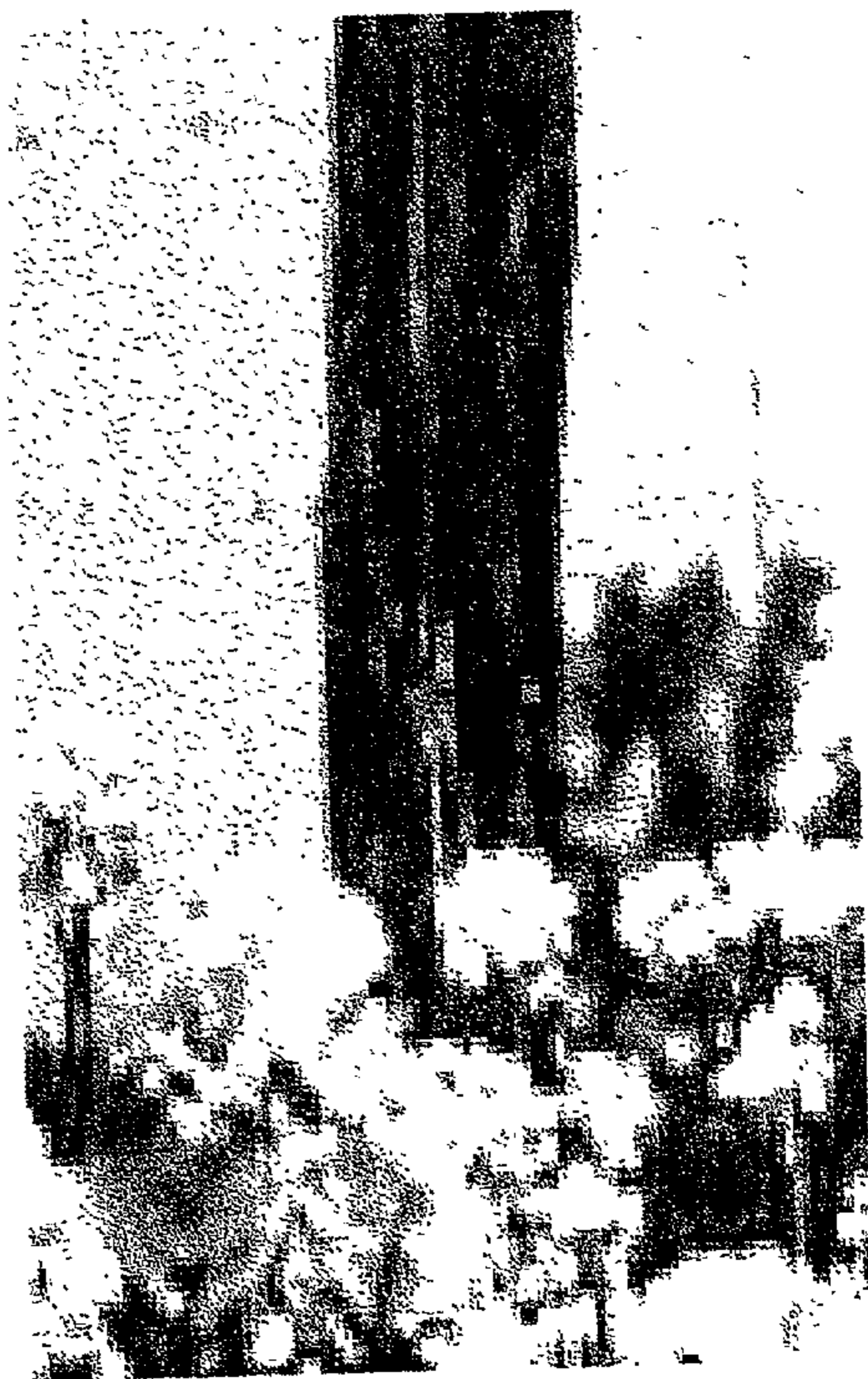
RED  
**FIG. 22A**



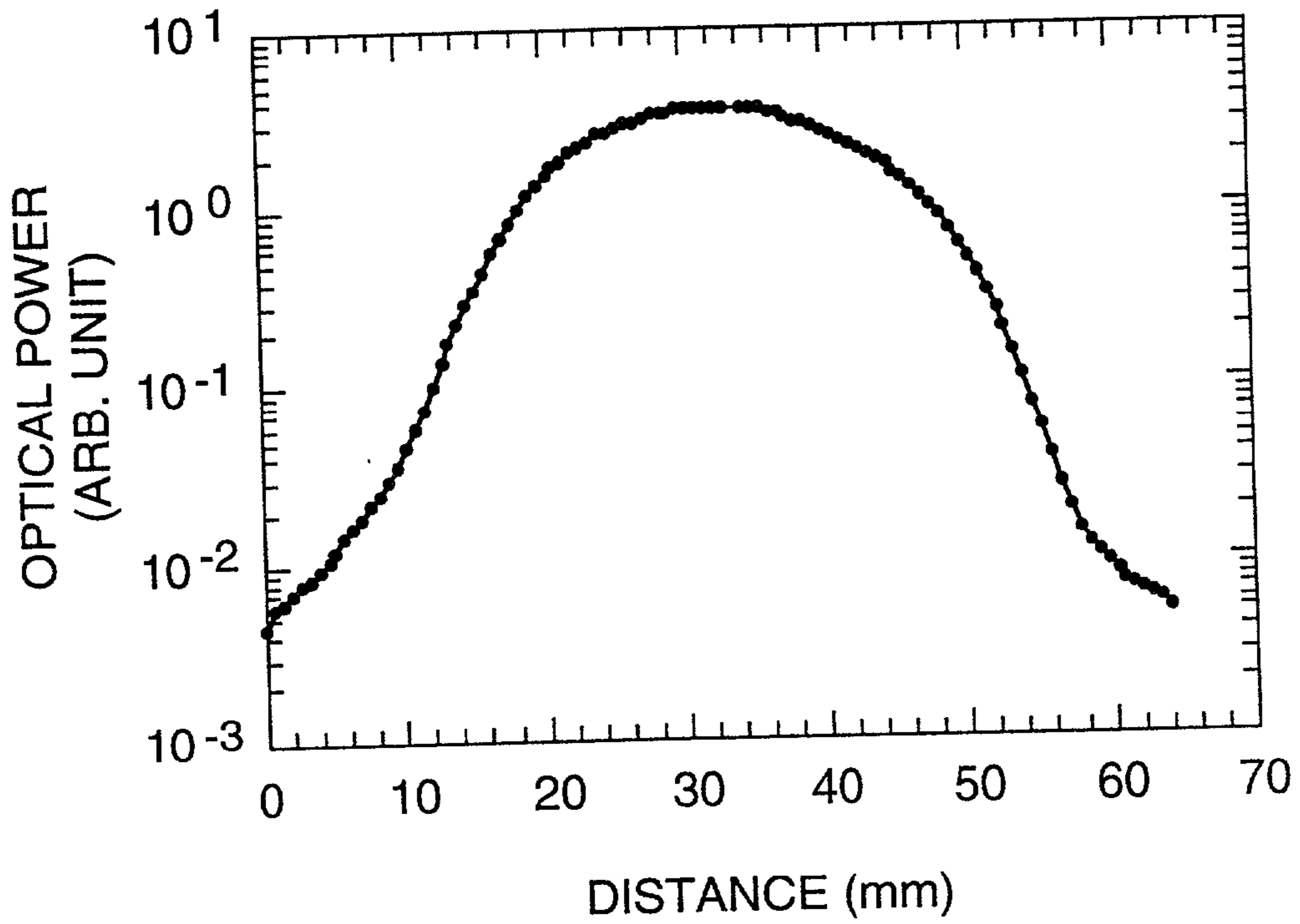
GREEN  
**FIG. 22B**



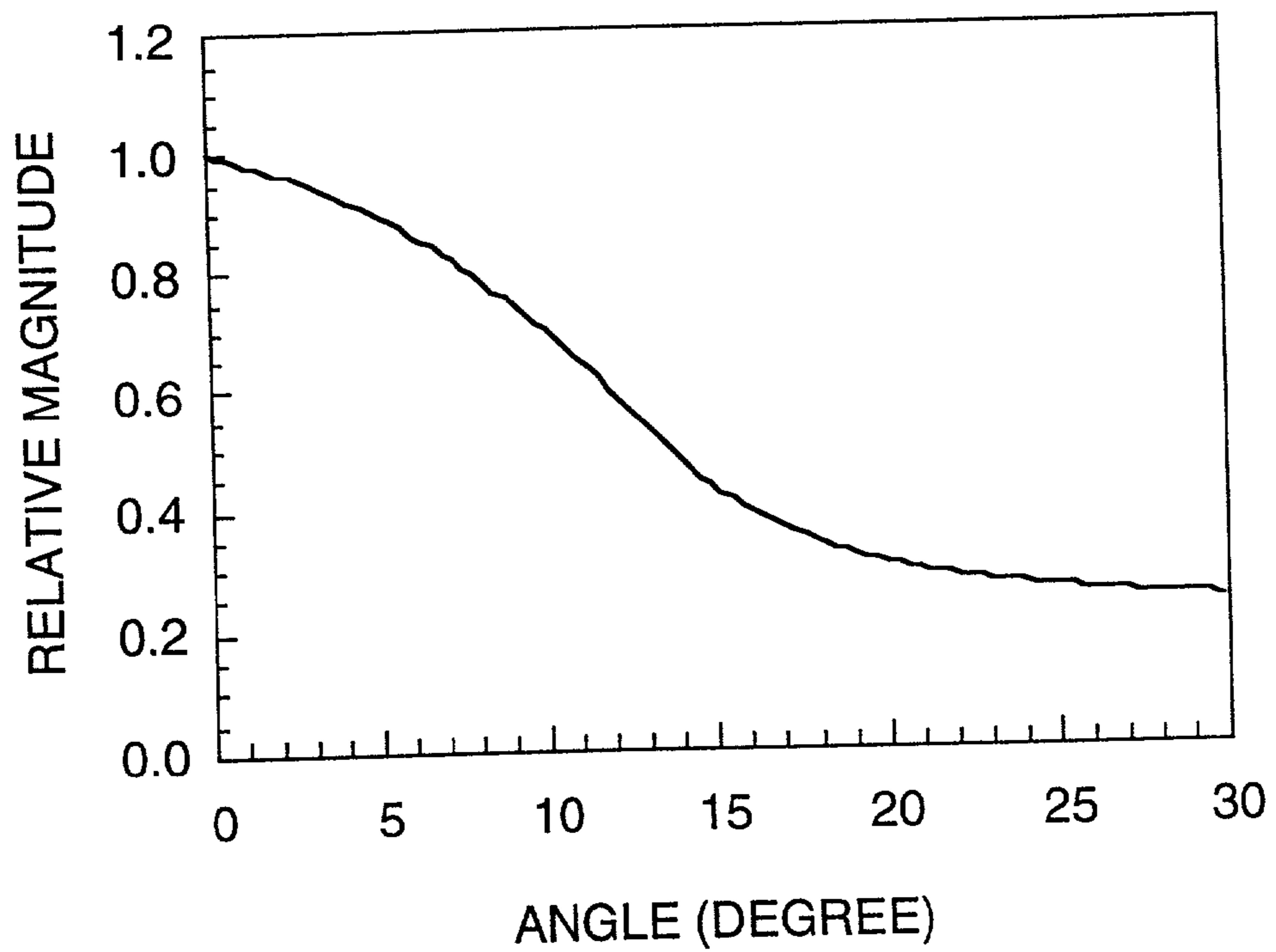
BLUE  
**FIG. 22C**



NATURAL  
**FIG. 22D**



**FIG. 23**



**FIG. 24**

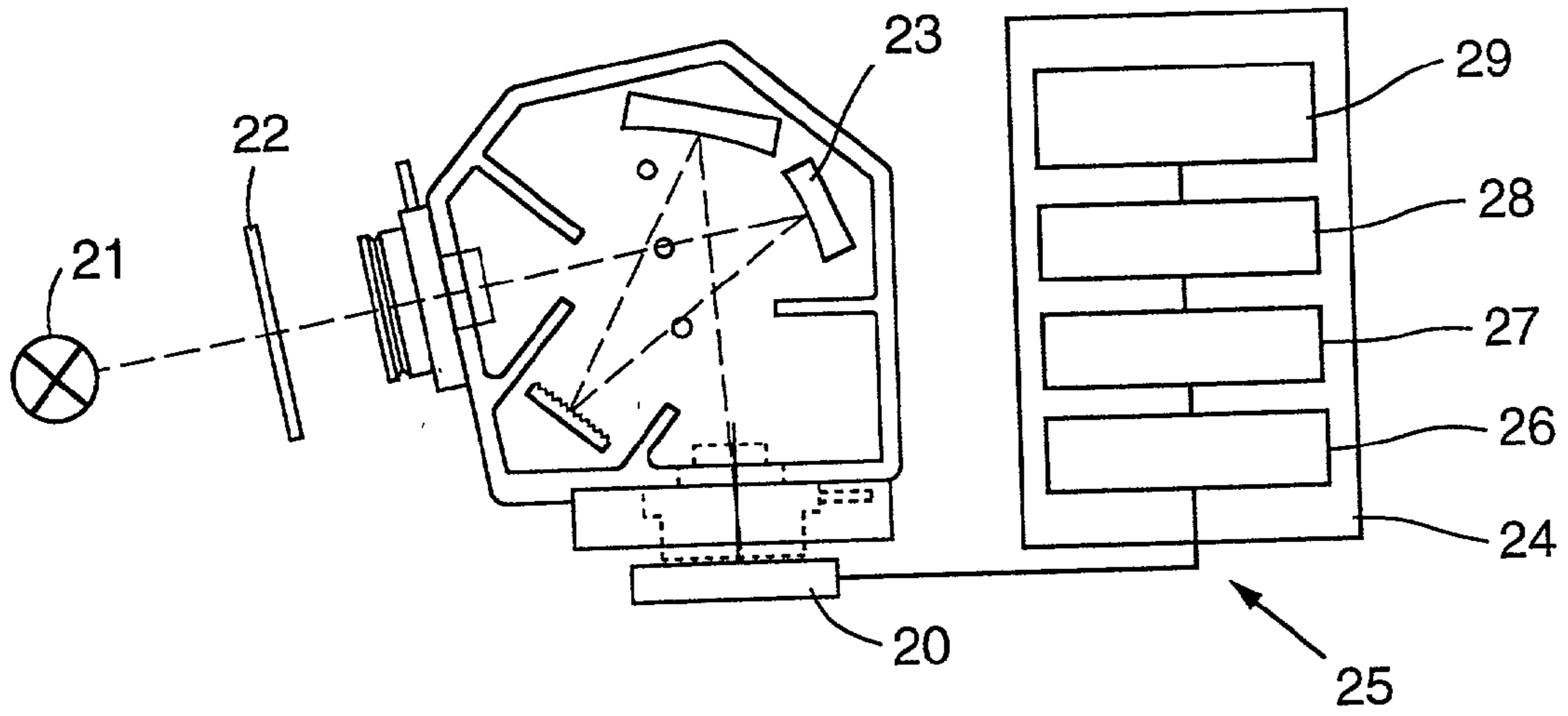


FIG. 25

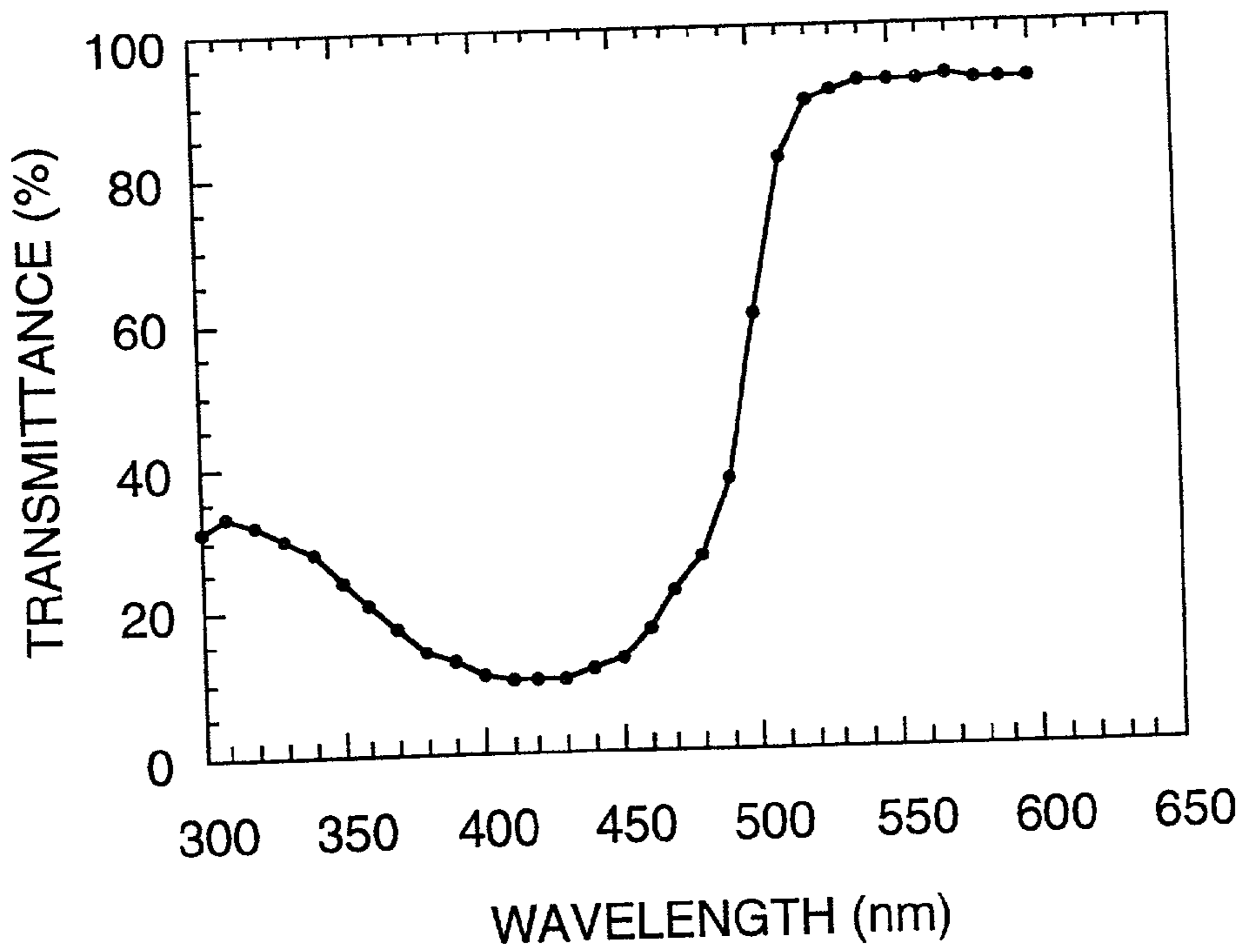
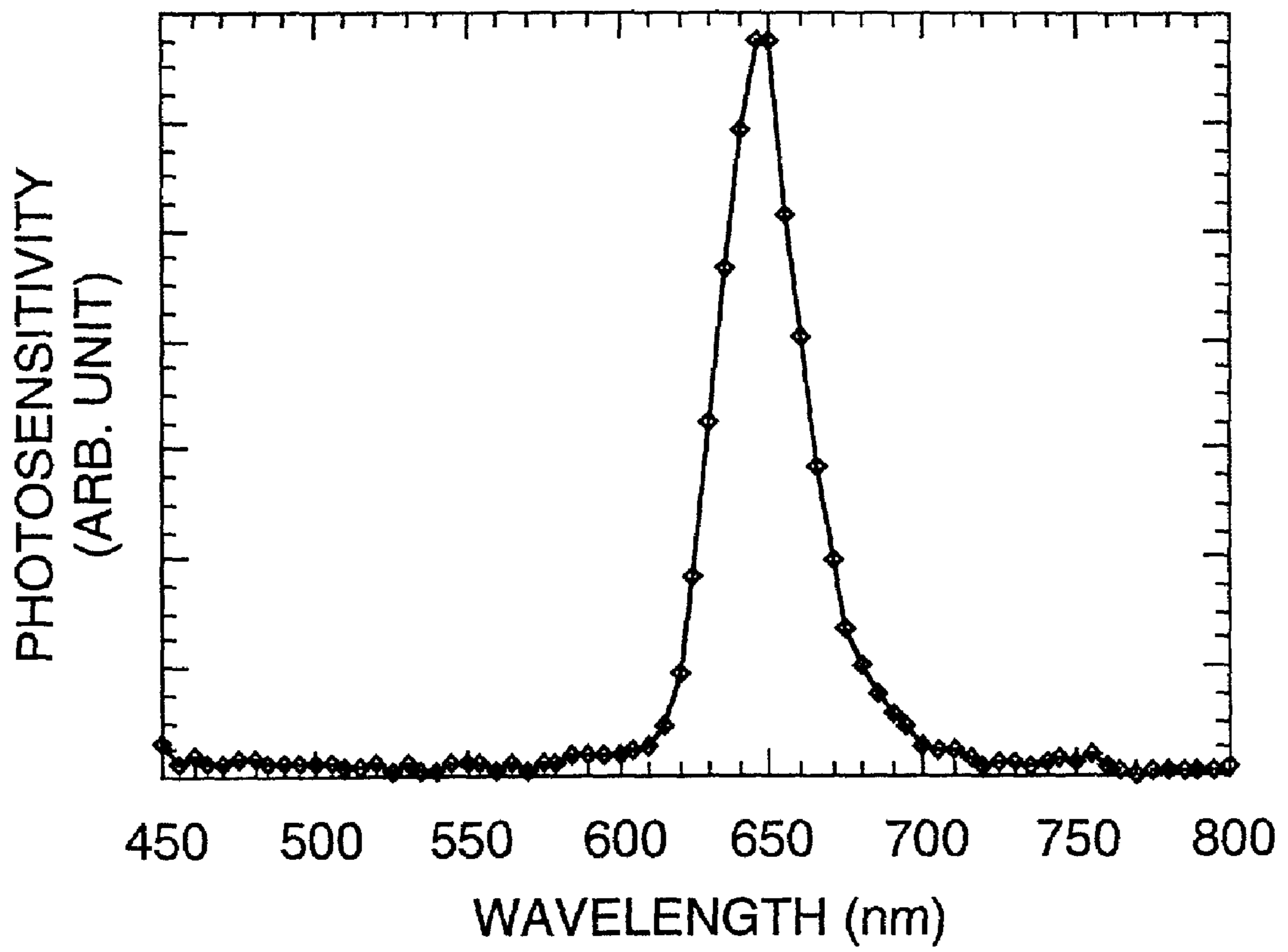


FIG. 26



**FIG. 27**

**ORGANIC DIODES WITH SWITCHABLE  
PHOTOSENSITIVITY USEFUL IN  
PHOTODETECTORS**

**CROSS-REFERENCE TO RELATED  
APPLICATIONS**

[0001] This application claims the benefit of U.S. Provisional Application No. 60/073,346, filed Feb. 2, 1998, which application is incorporated herein by reference in its entirety.

**STATEMENT REGARDING  
FEDERALLY-SPONSORED RESEARCH AND  
DEVELOPMENT**

[0002] This invention was made partially with Government support under Grant No. SBIR Ph I DMI 9660975 awarded by the National Science Foundation. Accordingly, the Government has certain rights to this invention.

**BACKGROUND OF THE INVENTION**

[0003] 1. Field of the Invention

[0004] The present invention relates to organic, polymer-based photodiodes and to their use in one and two dimensional image sensors. In more preferred embodiments, it concerns organic polymer-based photodiodes which are voltage switchable and which may be arrayed as image sensors in the form of a column-row (x-y) passively addressable matrix, where the x-y addressable organic image sensors (image arrays) have full-color or selected-color detection capability, or as linear photodiode arrays.

[0005] 2. State of the Art

[0006] The development of image array photodetectors has a relatively long history in the solid state device industry. Early approaches to imaging technology included devices based on thermal effects in solid state materials. These were followed by high sensitivity image arrays and matrices based on photodiodes and charge-coupling devices ("CCDs") made with inorganic semiconductors. These arrays can be simple linear (or "one dimensional") arrays which scan an image or they can be two dimensional, like the image.

[0007] Photodiodes made with inorganic semiconductors, such as silicon, represent a class of high quantum yield, photosensitive devices. They have been used broadly in visible light detection applications in the past decades. However, they characteristically present a flat current-voltage response, which makes it difficult to use them in fabricating high pixel density, x-y matrix-addressable passive image sensors. An "x-y" matrix is a two dimensional array with a first set of electrodes perpendicular to a second set of electrodes. When passive devices such as resistors, diodes or liquid crystal cells are used as the pixel elements at the intersection points, the matrix is often called a "passive" matrix in contrast to an "active" matrix in which active devices, such as transistors, are used to control the turn-on for each pixel.

[0008] To effectively address an individual pixel from the column and row electrodes in a two dimensional passive matrix, the pixel elements must exhibit strongly nonlinear current-voltage ("I-V") characteristics or an I-V dependence with a threshold voltage. This requirement provides the

foundation for using light-emitting diodes or liquid crystal cells to construct passive x-y addressable displays. However, since the photoresponse of inorganic photodiodes is voltage-independent in reverse bias, photodiodes made with inorganic semiconductor crystals are not practical for use in high pixel density, passive image sensors—there is too much cross-talk between pixels. To avoid cross-talk, existing two dimensional photodiode arrays made with inorganic photodiodes must be fabricated with each pixel wired up individually, a laborious and costly procedure. In the case of such individual connections, the number of input/output leads is proportional to the number of the pixels. The number of pixels in commercial two dimensional photodiode arrays is therefore limited to  $\leq 16 \times 16 = 256$  due to the difficulties in manufacturing and in making inter-board connections. Representative commercial photodiode arrays include the Siemens KOM2108 5x5 photodiode array, and the Hamamatsu S3805 16x16 Si photodiode array.

[0009] The development of charge-coupled devices ("CCDs") provided an additional approach toward high pixel density, two-dimensional image sensors. CCD arrays are integrated devices. They are different than x-y addressable matrix arrays. The operating principle of CCDs involves serial transfer of charges from pixel to pixel. These interpixel transfers occur repeatedly and result in the charge migrating, eventually, to the edge of the array for read-out. These devices employ super-large integrating circuit ("SLIC") technology and require an extremely high level of perfection during their fabrication. This makes CCD arrays costly ( $\sim \$10^3$ - $10^4$  for a CCD of 0.75"-1" size) and limits commercial CCD products to sub-inch dimensions.

[0010] The thin film transistor ("TFT") technology on glass or quartz substrates, which was developed originally for the needs of liquid crystal displays, can provide active-matrix substrates for fabricating large size, x-y addressable image sensors. A large size, full color image sensor made with amorphous silicon (a-Si) p-i-n photocells on a-Si TFT panels was demonstrated recently [R. A. Street, J. Wu, R. Weisfield, S. E. Nelson and P. Nylen, Spring Meeting of Materials Research Society, San Francisco, Apr. 17-21 (1995); J. Yorkston et al., Mat. Res. Soc. Sym. Proc. 116, 258 (1992); R. A. Street, Bulletin of Materials Research Society 11(17), 20 (1992); L. E. Antonuk and R. A. Street, U.S. Pat. No. 5,262,649 (1993); R. A. Street, U.S. Pat. No. 5,164,809 (1992)]. Independently, a parallel effort on small size, active-pixel photosensors based on CMOS technology on silicon wafers has been re-activated following developments in the CMOS technology which provide submicron resolution [For a review of recent progress, see: Eric J. Lemer, Laser Focus World 32(12) 54, 1996]. This CMOS technology allows the photocells to be integrated with the driver and the timing circuits so that a mono-chip image camera can be realized.

[0011] CCDs, a-Si TFTs, and active-pixel CMOS image sensors represent the existing/emerging technologies for solid state image sensors. However, because of the costly processes involved in fabrication of these sophisticated devices, their applications are severely limited. Furthermore, the use of SLIC technologies in the fabrication processes limits the CCDs and the active-pixel CMOS sensors to sub-inch device dimensions.

[0012] Photodiodes made with organic semiconductors represent a novel class of photosensors with promising

process advantages. Although there were early reports, in the 1980s, of fabricating photodiodes with organic molecules and conjugated polymers, relatively small photoresponse was observed [for an review of early work on organic photodiodes, see: G. A. Chamberlain, *Solar Cells* 8, 47 (1983)]. In the 1990s, there has been progress using conjugated polymers as the active materials; see for example the following reports on the photoresponse in poly(phenylene vinylene), PPV, and its derivatives: S. Karg, W. Riess, V. Dyakonov, M. Schwoerer, *Synth. Metals* 54, 427 (1993); H. Antoniadis, B. R. Hsieh, M. A. Abkowitz, S. A. Jenekhe, M. Stolka, *Synth. Metals* 64, 265 (1994); G. Yu, C. Zhang, A. J. Heeger, *Appl. Phys. Lett.* 64, 1540 (1994); R. N. Marks, J. J. M. Halls, D. D. C. Bradley, R. H. Friend, A. B. Holmes, *J. Phys.: Condens. Matter* 6, 1379 (1994); R. H. Friend, A. B. Homes, D. D. C. Bradley, R. N. Marks, U.S. Pat. No. 5,523,555 (1996)].

[0013] The photosensitivity in organic semiconductors can be enhanced by excited-state charge transfer; for example, by sensitizing the semiconducting polymer with acceptors such as C<sub>60</sub> or its derivatives [N. S. Sariciftci and A. J. Heeger, U.S. Pat. No. 5,331,183 (Jul. 19, 1994); N. S. Sariciftci and A. J. Heeger, U.S. Pat. No. 5,454,880 (Oct. 3, 1995); N. S. Sariciftci, L. Smilowitz, A. J. Heeger and F. Wudl, *Science* 258, 1474 (1992); L. Smilowitz, N. S. Sariciftci, R. Wu, C. Gettinger, A. J. Heeger and F. Wudl, *Phys. Rev. B* 47, 13835 (1993); N. S. Sariciftci and A. J. Heeger, *Intern. J. Mod. Phys. B* 8, 237 (1994)]. Photoinduced charge transfer prevents early time recombination and stabilizes the charge separation, thereby enhancing the carrier quantum yield for subsequent collection [B. Kraabel, C. H. Lee, D. McBranch, D. Moses, N. S. Sariciftci and A. J. Heeger, *Chem. Phys. Lett.* 213, 389 (1993); B. Kraabel, D. McBranch, N. S. Sariciftci, D. Moses and A. J. Heeger, *Phys. Rev. B* 50, 18543 (1994); C. H. Lee, G. Yu, D. Moses, K. Pakbaz, C. Zhang, N. S. Sariciftci, A. J. Heeger and F. Wudl, *Phys. Rev. B* 48, 15425 (1993)]. By using charge transfer blends as the photosensitive materials in photodiodes, external photosensitivity of 0.2-0.3 A/Watt and external quantum yields of 50-80% el/ph have been achieved at 430 nm at low reverse bias voltages [G. Yu, J. Gao, J. C. Hummelen, F. Wudl and A. J. Heeger, *Science* 270, 1789 (1995); G. Yu and A. J. Heeger, *J. Appl. Phys.* 78, 4510 (1995); J. J. M. Halls, C. A. Walsh, N. C. Greenham, E. A. Marseglia, R. H. Friend, S. C. Moratti and A. B. Holmes, *Nature* 376, 498 (1995)]. At the same wavelength, the photosensitivity of the UV-enhanced silicon photodiodes is ~0.2 A/Watt, independent of bias voltage [S. M. Sze, *Physics of Semiconductor Devices* (Wiley, New York, 1981) Part 5]. Thus, the photosensitivity of thin film photodiodes made with polymer charge transfer blends is comparable to that of photodiodes made with inorganic semiconducting crystals. In addition to their high photosensitivity, these organic photodiodes show large dynamic range; relatively flat photosensitivity has been reported from 100 mW/cm<sup>2</sup> down to nW/cm<sup>2</sup>; i.e., over eight orders of magnitude [G. Yu, H. Pakbaz and A. J. Heeger, *Appl. Phys. Lett.* 64, 3422 (1994); G. Yu, J. Gao, J. C. Hummelen, F. Wudl and A. J. Heeger, *Science* 270, 1789 (1995); G. Yu and A. J. Heeger, *J. Appl. Phys.* 78, 4510 (1995)]. The polymer photodetectors can be operated at room temperature, and the photosensitivity is relatively insensitive to the operating temperature,

dropping by only a factor of 2 from room temperature to 80 K [G. Yu, K. Pakbaz and A. J. Heeger, *Appl. Phys. Lett.* 64, 3422 (1994)].

[0014] As is the case for polymer light-emitting devices [G. Gustafsson, Y. Cao, G. M. Treacy, F. Klavetter, N. Colaneri, and A. J. Heeger, *Nature* 357, 477 (1992); A. J. Heeger and J. Long, *Optics & Photonics News*, Aug. 1996, p.24], high sensitivity polymer photodetectors can be fabricated in large areas by processing from solution at room temperature. They can be made in unusual shapes (e.g. on a hemisphere to couple with an optical component or an optical system), or they can be made in flexible or foldable forms. The processing advantages also enable one to fabricate the photosensors directly onto optical fibers. Similarly, polymer photodiodes can be hybridized with optical devices or electronic devices, such as an integrated circuits on a silicon wafer. These unique features make polymer photodiodes special for many novel applications.

#### SUMMARY OF THE INVENTION

[0015] Recent progress in our group has demonstrated that the photosensitivity in organic photodiodes can be enhanced by applying a reverse bias. It was further found that the photosensitivity increases with reverse bias voltage, with the increase being independent of incident light intensity [G. Yu, C. Zhang and A. J. Heeger, *Appl. Phys. Lett.* 64, 1540 (1994); A. J. Heeger and G. Yu, U.S. Pat. No. 5,504,323 (1996)]. This work showed a photosensitivity of ~90 mA/Watt in poly(2-methoxy-5-(2'-ethyl-hexyloxy)-1,4-phenylene vinylene) ("MEH-PPV")-based thin film devices, such as ITO/MEH-PPV/Ca thin film devices, at 10 V reverse bias (430 nm), corresponding to a quantum efficiency of >20% el/ph. In photodiodes fabricated with poly(3-octylthiophene), photosensitivity over 0.3 A/Watt was observed over most of visible spectral range at -15 V bias [G. Yu, H. Pakbaz and A. J. Heeger, *Appl. Phys. Lett.* 64, 3422 (1994)].

[0016] We have now found that this variable photosensitivity enables on-off voltage-switchable photosensors. At a reverse bias, typically in the range of 2-15 V, the photodiode can be switched on with photosensitivity of 30-300 mA/W. The photosensitivity at a voltage close to the internal (built-in) potential is several orders of magnitude lower, equivalent to zero at the output of a digital read-out circuit. This near zero state can thus be defined as the off state of the photodiode.

[0017] These voltage-switchable, organic photodiodes can serve as individual pixels in passive diode arrays. These arrays can be in the form of x-y addressable arrays with anodes connected via row (column) electrodes and cathodes connected via column (row) electrodes. Every pixel can be selected, and the information (intensity of the incident light) at each pixel can be read out without crosstalk. Alternatively, the voltage-switchable, organic photodiodes can be arrayed in a linear manner.

[0018] These arrays can utilize the processing advantages associated with the fabrication of organic diode structures from soluble, semiconducting, conjugated polymers (and/or their precursor polymers). Layers of these materials can be cast from solution to enable the fabrication of large active areas, onto substrates with desired shapes. This also enables active areas to be in flexible form. These photoactive materials can be patterned onto an optically uniform substrate by

means of photolithography, microcontact printing, shadow masking and the like. In a preferred embodiment for the visible region of the spectrum, the substrate is opaque for  $\lambda < 400$  nm so that the pixels are insensitive to UV radiation.

[0019] The photoactive layer employed in these switchable photodiodes is made up of organic materials. These take numerous forms. They can be conjugated semiconducting polymers or polymer blends. For donor-acceptor blends with polymeric donors, the acceptor can be a polymer, macromolecule, oligomer or small molecule (monomers). Alternatively, molecular donor/polymeric acceptor systems also work well. The higher molecular weight component in many cases provides mechanical strength and prevents phase changes. The donor-acceptor blends can also be made with small molecule donors and acceptors that are well known in the art. Examples of the molecular and oligomeric donors include anthracene and its derivatives, pinacyanol and its derivatives thiophene oligomers (such as sexithiophene, 6T, and octylthiophene, 8T) and their derivatives and the like, phenyl oligomers (such as sexiphenyl or octylphenyl) and the like. Examples of molecular acceptors include fullerenes (such as  $C_{60}$  and their functional derivatives),  $Alq_3$ -type organometallic molecules and the like. In addition, one can employ multiple layers of organic semiconducting materials in donor/acceptor heterojunction or quantum-well configurations.

[0020] The organic image sensors enabled by this invention can have mono-color or multi-color detection capability. In these image sensors color (optical wavelength) selection can be achieved by combining a suitable color filter panel with the organic image sensors and image sensor arrays already described. If desired, the color filter panel can serve as a substrate upon which the image sensor is carried. The detection wavelength of the organic image sensors can also be selected by using resonant cavity device structures as demonstrated in the examples of the invention. The organic image sensor arrays with the ability to select specific wavelengths can be used for spectrographic applications (such as flat-panel spectrometers).

[0021] In addition, embodiments of the present invention provide organic image sensors with full-color detection capability. In these organic image sensors, a filter panel is made up of red, green and blue color filters which are patterned in a format corresponding to the format of a photodiode array. The panel of patterned filters and the patterned photodiode array are coupled (and coordinated) such that a colored image sensor is formed. The patterned color filter panel can be used directly as the substrate of the image sensor.

[0022] Full-color detectivity, is also achieved when red, green and blue colors are detected by three of these photodiodes with spectral response cut-off at 500 nm, 600 nm and 700 nm, respectively. Differentiation operations in the read-out circuit extract the red (600-700 nm), green (500-600 nm) and blue (400-500 nm) signals.

#### BRIEF DESCRIPTION OF THE DRAWINGS

[0023] This invention will be further described with reference being made to the drawings in which:

[0024] FIG. 1 is a cross-sectional schematic view of a voltage-switchable photodiode of this invention 10

assembled into a circuit. The photocurrent can be read out by a current meter or a read-out device inserted in the loop;

[0025] FIG. 2 is a cross-sectional schematic view of a voltage-switchable photodiode 20 in reversed configuration, in which the reversed configuration refers the structure with the transparent electrode contacted with the free surface of the active layer;

[0026] FIG. 3 is an exploded schematic view of a 2D image sensor 30 made of an x-y addressable, passive matrix of voltage-switchable photodiodes;

[0027] FIG. 4 is an exploded schematic view of a full-color image sensor 40 made with an x-y addressable photodiode matrix coupled to a color filter panel;

[0028] FIG. 5 is an exploded schematic view of a full-color image sensor 50 made with an x-y addressable photodiode matrix of which each full-color pixel is made of three photosensitive materials having differing long-wavelength cut-offs such as at 700 nm, 600 nm and 500 nm;

[0029] FIG. 6 is a graph of the photocurrent as a function of bias voltage in a ITO/MEH-PPV/Ca device;

[0030] FIG. 7 is a graph of the transmission characteristics of PANI-CSA and PEDT-PSSA conducting polymer electrodes; also shown is the visual response,  $V(\lambda)$ , of human eye.

[0031] FIG. 8 is a graph of the photocurrent (circles) and the dark current (solid line) of a ITO/MEH-PPV:PCBM/Al photodiode. The photocurrent was taken under white light of intensity  $\sim 10$  mW/cm<sup>2</sup>.

[0032] FIG. 9 is a graph of the current-voltage characteristics of an ITO/P3OT/Au photodiode in the dark (circles), and illuminated under  $\sim 10$  mW/cm at 633 nm (squares);

[0033] FIG. 10 is a graph of the current-voltage characteristics measured between a row electrode and a column electrode from a 7×40 photodiode matrix in the dark (lines) and under room light illumination (circles);

[0034] FIG. 11 is a schematic representation of the driving scheme for a 7×40 photodiode matrix. It will be described in terms of ITO/MEH-PPV:PCBM/Ag switchable photodiodes;

[0035] FIG. 12 is a graph of the photoresponse of a voltage-switchable photodiode made with P3OT;

[0036] FIG. 13A is a graph of the photoresponse of voltage-switchable photodiodes with spectral response simulating that of human eye,  $V(\lambda)$ ;

[0037] FIG. 13B is a graph of the transmittance of the long-wavelength-pass filter and the visual response,  $V(\lambda)$  corresponding to FIG. 13A;

[0038] FIG. 14 is a graph of the spectral response of a solar blind UV detector operating at  $-2$ V. The photoresponse of the MEH-PPV: $C_{60}$  photodiode on ITO/glass substrate and the photoresponse of an UV-enhanced Si photodiode are plotted for comparison;

[0039] FIG. 15A is a graph of the response of a PTV photodiode;

[0040] FIG. 15B is a graph of the photoresponse of R, G, B photosensors made of PTV photodiodes coupled with a color-filter panel;

[0041] FIG. 15C is a graph of the transmittance of the color filters used in the generation of the data graphed in FIGS. 15A and 15B;

[0042] FIG. 16A is a graph of normalized spectral response of photodiodes made with PPV (open squares), PDHPV (open circles), and PTV (solid circles);

[0043] FIG. 16B is a graph of red, green and blue color detection derived from the diode responses in FIG. 16A;

[0044] FIG. 17 is a graph showing I-V response of a photodiode made with PPV in the dark and under illumination;

[0045] FIG. 18 is a graph showing I-V response of a photodiode with a donor/acceptor heterojunction structure in the dark and under illumination;

[0046] FIG. 19 is a graph of the dark (solid circles) and photocurrents (circles) of a P3HT photodiode under 8 mW/cm<sup>2</sup> broad band white light (400-700 nm);

[0047] FIGS. 20A and 20B are cross-sectional schematic views of linear photodiode arrays made with organic semiconductors;

[0048] FIG. 21 is a sketch of the circuit used to drive the organic photodiode array;

[0049] FIGS. 22A-D show images achieved by a P30T linear photodiode array of 100 pixels over a 2.5 inch length. FIG. 22A is a red color image; FIG. 22B is a green color image; FIG. 22C is a blue color image; and FIG. 22D is a full-color image recovered by superposing the red, green and blue color images of FIGS. 22A-C;

[0050] FIG. 23 is a graph of an optical beam analyzer made with a 1×10<sup>2</sup> polymer photodiode array;

[0051] FIG. 24 is a graph of the angular distribution of the light emission from a GaP LED measured with a flexible linear photodiode array;

[0052] FIG. 25 is a schematic view of a spectrographer made of P30T photodiode array;

[0053] FIG. 26 is a graph of the transmission spectra of a PPV film measured with the spectrographer of FIG. 25.

[0054] FIG. 27 is a graph of the spectral response of an organic photosensor in microcavity (optic etalon) structure.

#### DETAILED DESCRIPTION OF THE INVENTION

[0055] This invention provides high sensitivity photodiodes with voltage-switchable photosensitivity; the photosensitivity can be switched on and off by the application of selected voltages, thereby reducing cross-talk between pixels in an array of such voltage-switchable photodiodes to acceptable levels. These switchable photosensors enable the fabrication of either one- or two-dimensional (2D), passive image sensors with column-row (x-y) addressability. The voltage-switchable photodetector is constructed in a metal-semiconductor-metal (M-S-M) thin film structure in which an organic film such as a film of semiconducting polymer or a polymer blend is used as the photoactive material. Selected-color or multi-color detection in the visible and near UV can be achieved by coupling the image sensor to an optical filter(s). Fabrication processes for red, green and blue

(RGB) and full-color image sensors are described by coupling the x-y addressable polymer diode matrix or linear array with a RGB color filter panel, or by fabricating photodiodes with cut-off of the photoresponse at 500 nm, 600 nm and 700 nm, respectively, onto optically uniform substrates, or by fabricating the photodiodes in microcavity structures with defined spectral responses in the red, green and blue regions.

[0056] Voltage-switchable photodiodes make possible 2D image sensors. Using such photodiodes as the sensing elements in a column-row matrix, a 2D x-y addressable, passive image sensor can be constructed which operates without crosstalk. Because of the strong voltage dependence of the photosensitivity, a column of pixels in the 2D photodiode matrix can be selected and turned on with proper voltage bias, leaving the rest of the pixels on other rows insensitive to the incident light. With this type of operation, the physical M row, N column 2D matrix is reduced to N isolated linear diode arrays each with M elements; said isolated linear diode arrays are free from the crosstalk which originates from finite resistance between devices on different columns. With such 2D, passive photodiode arrays, an image can be read out with a pulse train scanning through each column of the matrix. Since the number of contact electrodes are reduced to N+M in the x-y addressable matrix, compared to N×M in the case of individual connection, large size, high pixel density, 2D image arrays become practical (comparable to the high pixel density display arrays made with LCD technology). For example, for a 1000 by 1000 pixel array, the present invention reduces the number or required electrodes by 500 times. The polymer image sensor matrix thus provides a unique approach to fabricating large size, low cost, high pixel density, 2D image sensing arrays with a room temperature manufacturing process.

[0057] In addition to being used as the sensing elements in x-y addressable, 2D passive photodiode matrices, these voltage-switchable organic photosensors can also be used to construct linear photodiode arrays. As shown in examples disclosed in this invention, the ratio of  $I_{ph}(V_{on})/I_{ph}(V_{off})$  can be more than  $3 \times 10^7$  under photoexcitation of a few mW/cm<sup>2</sup>. The large  $I_{ph}(V_{on})/I_{dark}(V_{on})$  ratio ( $>1.3 \times 10^5$ ) allows the collection of image data with gray scale resolution of more than 12 bits (12 bit has 4096 gray levels). Linear photodiode arrays made with these materials can be used for high image quality (over 18 bits), full-page color digital image scanners. Contrary to active image sensors, no analog switches are needed to drive these arrays. A digital shift register or a BCD decoder can be used for pixel selection.

[0058] The device structure of the linear photodiode array is shown in FIG. 19. Transparent glass or PET films can be used as the substrates. Opaque materials such as silicon wafers can also be used as the substrate material. In this case, the light is incident onto the free surface side as shown in FIG. 19B. When organic PET films are used as substrates, the linear diode array can be made in flexible form. Optical devices with curved surface can also be used as the substrate for these diode arrays; i.e., the linear diode array can be coupled to and integrated with other optical devices in a desired optical arrangement and with a desired optical wavefront.



[0059] Linear photodiode arrays can be made in the configurations similar to that shown in FIG. 3 with one row and n columns or with one column and n rows. The cross sectional views of two typical device structures are shown in FIG. 19. The substrates can be transparent or opaque. In a preferred configuration (FIG. 19A), the linear photodiode arrays (210) can be fabricated onto a transparent glass substrate (214) with patterned ITO (211) or other transparent electrode materials (such as conducting polymer electrodes, thin metal films, metal/conducting polymer bilayer electrodes dielectric film/ITO or metal film/dielectric film bilayer electrodes). The process of ITO patterning is well known in the existing art, and has been used broadly in LCD technologies. The deposition of the organic layer (212) can be achieved by spin casting, drop casting, printing, electrochemical synthesis or vapor deposition. The back electrode, in the form of a narrow bar shape (213), can be vacuum deposited with a simple shadow mask or patterned by means of photolithography. In most applications (especially for larger pixel sizes), no patterning of the sensing material is necessary. This sensing array can be mounted onto a print circuit (PC) board with a driving circuit. Several existing connection techniques (such as card-edge connectors, zebra connectors, bonding tapes, wire bonding, soldering bumper etc.) can be used for interboard connection. The drive circuits can also be arranged (surrounding the sensor array) onto the same substrate. This is especially preferred in arrays with a high pixel density (e.g., >80 pixels/inch). In these cases, the IC chips can be bonded to the glass substrate, and the electrical connections can be achieved via soldering, one-dimensional conducting epoxy or other existing connection technologies.

[0060] As demonstrated in the examples herein, the spectral response of the polymer image sensors can cover the entire visible spectrum with relatively flat response. A portion of the visible spectrum can also be selected with a band-pass or low-pass optical filter. Multi-color detection in the visible and the near UV can be achieved by coupling the image sensor with a color-filter panel. A fabrication process for full-color image sensors is described with the x-y addressable polymer diode matrix and a RGB (red, green, blue) color filter panel. A similar fabrication process can be employed to prepare a linear photodiode array.

#### [0061] Definitions and Device Structures

[0062] In this description of preferred embodiments and in the claims, reference will be made to several defined terms. One group of terms concerns the structure of the voltage-switchable photodiode. A cross-sectional view of the voltage-switchable photodiode is shown in FIG. 1. The voltage-switchable photodiode 10 is constructed using the metal-semiconductor-metal (M-S-M) thin film device configuration. Specifically, the device 10 includes:

[0063] A “photoactive layer” (layer 12) comprised of organic, semiconducting material(s), such as a conjugated polymer, a polymer blend, a polymer/molecule polyblend, a layer of organic molecule or molecular blends; or a multilayer structure combining the above materials;

[0064] Two “contact electrodes” (layers 11, 13) which serve as the anode and cathode of the photodiodes to extract electrons and holes, respectively, from the photoactive layer. One of the electrodes

(layer 11 in FIG. 1) is made transparent or semi-transparent in the spectral range of interest to allow the incident light 18 to be absorbed in the active layer (12).

[0065] The “anode” electrode is defined as a conducting material with higher work function than the “cathode” material.

[0066] This same relationship of electrodes 11 and 13 to active layer 12 and light source 18 (or 18') is found in devices 10, 20, 30, 40 and 50 as depicted in FIGS. 1, 2, 3, 4, and 5, respectively.

[0067] As shown in FIGS. 1 and 2, electrodes 11 and 13 are connected to bias voltage source 15 via lines 17 and 17', respectively. Detector 16 (that represents a current meter or a read out device) is wired in series into this circuit to measure the photoresponse generated in the photodiode in response to light 18. This same circuit would be employed in all of the devices (10, 20, 30, 40 and 50) depicted in FIGS. 1-5.

[0068] The devices may also include an optional substrate or support 14, as shown in FIGS. 1-5. This is a solid, rigid or flexible layer designed to provide robustness to the diodes and/or to the matrix array of diodes. When light is incident from the substrate side, the substrate should be transparent or semitransparent in the spectral range of interest. Glass, polymer sheets or flexible plastic films are substrates commonly used. Wide band semiconductor wafers (such as SiC, SiN) which are transparent below their optical gaps can also be used in some applications. In these cases, a thin, doped region can also serve as the contact electrode 11.

[0069] Devices with the inverted geometry shown in FIG. 2 are also useful in applications. In this configuration, light 18 is incident from the “back” electrode side, and optically opaque materials can be used as the substrate material. For example, by using an inorganic semiconductor wafer (such as silicon) as the substrate 14, and by doping the semiconductor to “conductive” levels (as defined in the following), the wafer can serve both as the substrate 14 and the contact electrode 11. The inverted structure offers the advantage of integrating the photosensor with driving/read-out circuitry built directly onto the inorganic semiconductor substrate (using integrated circuit technology).

[0070] The incident light 18 (or 18') is defined generally so as to include wavelengths in visible (400-700 nm), wavelengths in the ultraviolet (200-400 nm), wavelength in the vacuum UV (<200 nm), and wavelengths in the infrared (700-2000 nm).

[0071] Several layers are designated as “transparent” or “semi-transparent”. These terms are used to refer to the property of a material which transmits a substantial portion of the incident light incident on it. The term “transparent” is used to describe a substrate with transmittance over 50% and the term “semi-transparent” is used to describe a substrate with transmittance between 50% to 5%.

[0072] A “conductive” layer or material has a conductivity typically larger than 0.1 S/cm. A semiconducting material has conductivity of from  $10^{-14}$  to  $10^{-1}$  S/cm.

[0073] The “positive” (or “negative”) bias refers to the cases when higher potential is applied to the anode electrode (cathode electrode). When values of negative voltage are

referred to, as in the case of the reverse bias voltages applied to obtain enhanced photosensitivity, the relative values will be stated in terms of absolute values; that is, for example, a  $-10$  V (reverse) bias is greater than a  $-5$  V (reverse) bias.

[0074] The structure of the x-y addressable, passive photodiode matrix (2D image sensor **30**) is depicted in **FIG. 3**. Shown in **FIG. 4** is the structure of a full-color image sensor **40** made with the x-y addressable photodiode matrix. In these devices, the anode and cathode electrodes **11'**, **13'** are typically patterned into rows and columns perpendicular to one another. Patterning of the photoactive layer **13** is not necessary for pixels with sufficient space between adjacent electrodes. Each intersection of the row and column electrodes defines a photosensitive element (pixel) with device structure similar to that shown in **FIG. 1** or **FIG. 2**. The widths of the row and column electrodes **11'**, **13'** define the active area of each pixel.

[0075] A matrix of color filters **19** (each pixel of the color filter is comprised of red, green and blue color filters **19'**) is coupled with the photodiode panel. A separate sheet of color filters similar to that used for color-LCD displays [For a review, see: M. Tani and T. Sugiura, Proceeding of SID, Orlando, Fla. (1994)] can be used for this purpose. In a more preferred embodiment, the color-filter panel can be coated directly onto the substrate for the photodiode matrix. The set of transparent electrodes **11** (for example, made of indium-tin-oxide, ITO) can be fabricated over the color filter coating. In this configuration, high pixel densities with micron-size feature size can be achieved.

[0076] A coating of "black" material (opaque in the spectral range of interest) in the area between each sensing pixel can be placed in front of the photodetector plane, forming a "black matrix". This coating is helpful in some situations to further reduce cross-talk between neighbor pixels in devices with an unpatterned photoactive organic layer. Black matrices have been used in CRT monitors and other flat panel displays to increase display contrast, and are well known in the display industry. The patterning of the "black matrix" can be achieved with standard photolithography, stamp, ink-jet or screen printing techniques.

[0077] Full-color detection can be achieved with an alternative approach **50** as shown in **FIG. 5**. In this approach, each full-color pixel **12'** comprises three photodiodes **12R**, **12G** and **12B** with long wavelength cut-offs at 700, 600 and 500 nm, respectively. These photodiodes are made of three photosensitive materials in the defined areas on the substrate. The patterning of the active layers can be achieved by photolithography, screen printing, shadow masking and the like. The correct red, green and blue color information can be obtained by differentiation of the signals (in the read-out circuit) from the three sub-pixels, **12R**, **12G** and **12B**, as demonstrated in the examples of this invention. An optically uniform material is used as the substrate which is transparent in the visible and opaque in UV.

[0078] The color selection can also be achieved by combining the device structure shown in **FIG. 4** with that shown in **FIG. 5**. For instance, with the photosensing material in the photodiode defining part of the spectral response, the optical filter placed in front fine-tunes the response desired. Example 15 utilizes this approach for a photosensor simulating the response of the human eye.

[0079] The Photoactive Layer

[0080] The photoactive layer **12** in the voltage-switchable photodiodes is made of a thin sheet of organic semiconducting material. The active layer can comprise one or more semiconducting, conjugated polymers, alone or in combination with non-conjugated materials, one or more organic molecules, or oligomers. The active layer can be a blend of two or more conjugated polymers with similar or different electron affinities and different electronic energy gaps. The active layer can be a blend of two or more organic molecules with similar or different electron affinities and different electronic energy gaps. The active layer can be a blend of conjugated polymers and organic molecules with similar or different electron affinities and different energy gaps. The latter offers specific advantages in that the different electron affinities of the components can lead to photoinduced charge transfer and charge separation; a phenomenon which enhances the photosensitivity [N. S. Sariciftci and A. J. Heeger, U.S. Pat. No. 5,333,183 (Jul. 19, 1994); N. S. Sariciftci and A. J. Heeger, U.S. Pat. No. 5,454,880 (Oct. 3, 1995); N. S. Sariciftci, L. Smilowitz, A. J. Heeger and F. Wudl, Science 258, 1474 (1992); L. Smilowitz, N. S. Sariciftci, R. Wu, C. Gettinger, A. J. Heeger and F. Wudl, Phys. Rev. B 47,13835 (1993); N. S. Sariciftci and A. J. Heeger, Intern. J. Mod. Phys. B 8, 237 (1994)]. The active layer can also be a series of heterojunctions utilizing layers of organic materials or blends as indicated above.

[0081] The thin films of organic molecules, oligomers and molecular blends can be fabricated with thermal evaporation, chemical vapor deposition (CVD) and so on. Thin films of conjugated polymers, polymer/polymer blends, polymer/oligomer and polymer/molecule blends can often be fabricated by casting directly from solution in common solvents or using similar fluid phase processing. When polymers or polyblends are used as the active layer, the devices can be fabricated onto flexible substrates yielding unique, mechanically flexible photo sensors.

[0082] Examples of typical semiconducting conjugated polymers include, but are not limited to, polyacetylene, ("PA"), and its derivatives; polyisothianaphene and its derivatives; polythiophene, ("PT"), and its derivatives; polypyrrole, ("PPr"), and its derivatives; poly(2,5-thienylenevinylene), ("PTV"), and its derivatives; poly(p-phenylene), ("PPP"), and its derivatives; polyfluorene, ("PF"), and its derivatives; poly(phenylene vinylene), ("PPV"), and its derivatives; polycarbazole and its derivatives; poly(1,6-heptadiyne); polyisothianaphene and its derivatives; polyquinolene and semiconducting polyanilines (i.e. leucoemeraldine and/or the emeraldine base form). Representative polyaniline materials are described in U.S. Pat. No. 5,196,144 which is incorporated herein by reference. Of these materials, those which exhibit solubility in organic solvents are preferred because of their processing advantages.

[0083] Examples of PPV derivatives which are soluble in common organic solvents include poly(2-methoxy-5-(2'-ethyl-hexyloxy)-1,4-phenylene vinylene), ("MEH-PPV") [F. Wudl, P. -M. Allemand, G. Srdanov, Z. Ni and D. McBranch, in Materials for Nonlinear Optics: Chemical Perspectives, edited by S. R. Marder, J. E. Sohn and G. D. Stucky (The American Chemical Society, Washington D.C., 1991), p. 683.], poly(2-butyl-5-(2-ethyl-hexyl)-1,4-phenylenevinylene), ("BuEH-PPV") [M. A. Andersson, G. Yu, A. J.

Heeger, Synth. Metals 85, 1275 (1997)], poly(2,5-bis(c-holestanoxo)-1,4-phenylenevinylene), ("BCHA-PPV") [see U.S. patent application Ser. No. 07/800,555, incorporated herein by reference] and the like. Examples of soluble PTs include poly(3-alkylthiophenes), ("P3AT"), wherein the alkyl side chains contain more than 4 carbons, such as from 5 to 30 carbons.

[0084] Organic image sensors can be fabricated using donor/acceptor polyblends as the photoactive layer. These polyblends can be blends of semiconducting polymer/polymer, or blends of semiconducting polymer with suitable organic molecules and/or organometallic molecules. Examples for the donor of the donor/acceptor polyblends include but are not limited to the conjugated polymers just mentioned, that is PPV, PT, PTV, and poly(phenylene), and their soluble derivatives. Examples for the acceptors of the donor/acceptor polyblends include but are not limited to poly(cyanoophenylenevinylene) ("CN-PPV"), fullerene molecules such as C<sub>60</sub> and its functional derivatives, and organic molecules and organometallic molecules used heretofore in the art for photoreceptors or electron transport layers.

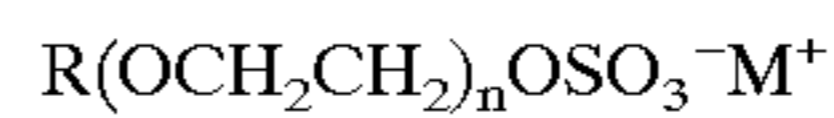
[0085] One can also produce photoactive layers using two semiconducting organic layers in a donor/acceptor heterojunction (i.e., bilayer) structure or alternation layer structures. In these structures, the donor layer is typically a conjugated polymer layer and the acceptor layer is made up of poly(cyanoophenylenevinylene) ("CN-PPV"), fullerene molecules such as C<sub>60</sub> and its functional derivatives (such as PCBM and PCBCR), or organic molecules used heretofore in the art for photoreceptors and electron transport layers. Examples of this heterojunction layer structure for a photoactive layer include but are not limited to, PPV/C<sub>60</sub>, MEH-PPV/C<sub>60</sub>, PT/C<sub>60</sub>, P3AT/C<sub>60</sub>, PTV/C<sub>60</sub> and so on.

[0086] The active layer can also be made of wide band polymers such as poly-N-vinylcarbazole ("PVK") doped with dye molecule(s) to enhance photosensitivity in the visible spectral range. In these cases, the wide band organic serves as both host binder as well as hole (or electron) transport material. Examples include, but are not limited to, PVK/o-chloranil, PVK/rhodamine B and PVK/coronene and the like.

[0087] The photoactive layer can employ organic molecules, oligomers or molecular blends. In this embodiment, the photosensitive material can be fabricated into thin films by chemical vapor deposition, molecular epitaxy or other known film-deposition technologies. Examples of suitable materials include but are not limited to include anthracene and its derivatives, tetracene and its derivatives, phthalocyanine and its derivatives, pinacyanol and its derivatives, fullerene ("C<sub>60</sub>") and its derivatives, thiophene oligomers (such as sixethiophene "6T" and octithiophene "8T") and their derivatives phenyl oligomers (such as sixphenyl "6P" or octiphenyl "8P") and their derivatives, aluminum chelate (Alq3) and other metal-chelate molecules (m-q3), PBD, spiro-PBD, oxadiazole and its derivatives and blends such as 6T/C<sub>60</sub>, 6P/C<sub>60</sub>, 6P/PBD, 6P/Alq3, 6T/pinacyanol, phthalocyanine/o-chloranil, anthracene/C<sub>60</sub>, anthracene/o-chloranil. For the photoactive layer containing more than two types of molecules, the organic layer can be in a blend form, in bilayer form or in multiple alternate layer forms.

[0088] In some embodiments, the active layer comprises one or more organic additives (which are optically non-

active) to modify and to improve the device performance. Examples of the additive molecules include anionic surfactants such as ether sulfates with a common structure,



[0089] wherein R represents alkyl alkylaryl,

[0090] M<sup>+</sup> represents proton, metal or ammonium counterion,

[0091] n is moles of ethylene oxide typically n=2-40).

[0092] Application of such anionic surfactants as additives for improving the performance of polymer light-emitting diodes has been demonstrated by Y. Cao [U.S. patent application, Ser. No. 08/888,316, which is incorporated by reference].

[0093] Other types of additives include solid state electrolytes or organic salts. Examples include poly(ethylene oxide), lithium trifluoromethanesulfonate, or their blends, tetrabutylammonium dodecylbenzenesulfonate and the like. Application of such electrolyte to luminescent polymers and invention of new type of light-emitting devices have been demonstrated in U.S. Pat. Nos. 5,682,043 and 5,677,546.

[0094] In cases where the active layer is made of organic blends with two or more phases with different electron affinities and optical energy gaps, nanoscale phase separation commonly occurs, and heterojunctions form at the interfacial area. The phase(s) with higher electron affinity acts as an electron acceptor(s) while the phases with lower electron affinity (or lower ionization energy serves as an electron donor(s)). These organic blends form a class of charge-transfer materials, and enable the photo-initiated charge separation process defined by the following steps [N. S. Sariciftci and A. J. Heeger, Intern. J. Mod. Phys. B 8, 237 (1994)]:

[0095] Step 1: D+A<sup>1,3</sup>D\*+A, (excitation on D);

[0096] Step 2: <sup>1,3</sup>D\*+A<sup>1,3</sup>(D-A)\*, (excitation delocalized on D-A complex);

[0097] Step 3: <sup>1,3</sup>(D-A)\*<sup>1,3</sup>(D<sup>d+</sup>-A<sup>d-</sup>)\*, (charge transfer initiated);

[0098] Step 4: <sup>1,3</sup>(D<sup>d+</sup>-A<sup>d-</sup>)\*<sup>1,3</sup>(D<sup>+°</sup>-A<sup>-°</sup>), (ion radical pair formed);

[0099] Step 5: <sup>1,3</sup>(D<sup>+°</sup>-A<sup>-°</sup>)D<sup>+°</sup>+A<sup>-°</sup>, (charge separation)

[0100] where (D) denotes the organic donor and (A) denotes the organic acceptor; 1,3 denote singlet or triplet excited states, respectively.

[0101] Typical thickness of the active layer range from a few hundred Ångstrom units to a few thousand Ångstrom units; i.e., 100-5000 Å (1 Ångstrom unit=10<sup>-8</sup> cm). Although the active film thicknesses are not critical, device performance can typically be improved by using thinner films with optical densities of less than two in the spectral region of interest.

[0102] Electrodes

[0103] As shown in FIGS. 1 and 2, the organic photo-diodes of this invention are constructed in an M-S-M structure, in which the organic photoactive layer is bounded

on two sides with conductive contact electrodes. In the configuration shown in **FIG. 1**, a transparent substrate **14** and a transparent electrode **11** are used as one contact electrode. Indium-tin-oxides (“ITO”) can be used as the electrode **11**. Other transparent electrode materials include aluminum doped zinc oxides (“AZO”), aluminum doped tin-oxides (“ATO”), tin-oxides and the like. These conducting coatings are made of doped metal-oxide compounds which are transparent from near UV to mid-infrared.

[0104] The electrode **11** can also be made with other doped inorganic compounds or alloys. These compounds can be doped into metallic (or near metallic) form by varying the composition of the elements involved, the valance of the elements or the morphology of the films. These semiconducting or metallic compounds are known in the art and are well documented (e.g., N. F. Mott, *Metal-Insulating Transitions*, 2nd edition (Taylor & Francis, London, 1990); N. F. Mott and E. A. Davis, *Electronic Processes in Non-crystalline Materials* (Clarendon, Oxford, 1979)]. Examples of such compounds include the cuprate materials which possess superconductivity at low temperatures (so-called high temperature superconductors).

[0105] The electrode **11** in **FIG. 1** (or **13** in **FIG. 2**) can be formed of a conductive polymer such as polyaniline in the emeraldine salt form prepared using the counterion-induced processability technology disclosed in U.S. Pat. No. 5,232,631 and in *Appl. Phys. Lett.* 60, 2711 (1992) or other suitable techniques. The polyaniline film which serves as the electrode can be cast from solution with high uniformity at room temperature. The organic conducting electrodes in combination with polymer substrates and organic active layers allow these photosensors be fabricated in fully flexible form. Other conductive polymers can be used for the transparent or semitransparent electrode (**11** in **FIG. 1** or **13** in **FIG. 2**) include polyethylene dioxythiophene polystyrene sulfonate, (“PEDT/PSS”) [Y. Cao, G. Yu, C. Zhang, R. Menon and A. J. Heeger, *Synth. Metals*, E, 171 (1997)], poly(pyrrole) or its function derivatives doped with dodecylbenzene sulfonic acid (“DBSA”) or other acid [J. Gao, A. J. Heeger, J. Y. Lee and C. Y. Kim, *Synth. Metals* 82, 221 (1996)] and the like.

[0106] A thin semitransparent layer of metals (such as Au, Ag, Al, In etc.) can also be used as the electrode **11** in **FIG. 1** and **13** in **FIG. 2**. Typical thicknesses for this semitransparent metal electrode are in the range of 50-1000 Å, with optical transmittance between 80% and 1%. A proper dielectric coating (often in the form of multilayer dielectric stacks) can enhance the transparency in the spectral range of interest [For examples, see S. M. Sze, *Physics of Semiconductor Devices* (John Wiley & Sons, New York, 1981) Chapter 13].

[0107] A transparent electrode can also be made from metal/conducting polymer, conducting polymer/metal/conducting polymer or dielectric layer/metal/conducting polymer structures. The transmission properties of these composite electrodes are improved relative to that of a single metal layer of the same thickness.

[0108] A metal layer with low optical transmittance can also be used as the electrode **11** for some applications in which spectral response at certain wavelengths is of interest. The photosensitivity can be enhanced by fabricating the device in a micro-cavity structure where the two metal electrodes **11** and **13** act also as optical mirrors. Light

resonance between the two electrodes enhances the photosensitivity at certain wavelengths and results in selective spectral response, similar to that seen in optical microcavity (optical etalon) devices.

[0109] The “back” electrode **13** in **FIG. 1** (and **11** in **FIG. 2**) is typically made of a metal, such as Ca, Sm, Y, Mg, Al, In, Cu, Ag, Au and so on. Metal alloys can also be used as the electrode materials. These metal electrodes can be fabricated by, for example, thermal evaporation, electron beam evaporation, sputtering, chemical vapor deposition, melting process or other technologies. The thickness of the electrode **13** in **FIG. 1** (and **11** in **FIG. 2**) is not critical and can be from hundreds of Ångstroms to hundreds of microns or thicker. The thickness can be controlled to achieve a desired surface conductivity.

[0110] When desired, for example, for a photodiode with detectivity on both front and back side, the transparent and semi-transparent materials described above can also be used as the “back” electrode **13** in **FIG. 1** (and **11** in **FIG. 2**).

[0111] The patterning of the row and column electrodes shown in **FIG. 3** and **FIG. 4** can be achieved by standard patterning technologies well-known in semiconductor industry such as shadow masking, photolithographing, silk-screen printing or stamp (microcontact) printing etc. These methods are well known to those knowledgeable of the art of display and image sensor technologies.

[0112] To improve the device performance (for example, device lifetime, operation speed etc.), a buffer layer comprising conducting polymers or blends containing them can be inserted in between the electrode **11** (or **13**) and the photoactive layer. The conductivity of the buffer layer can be chosen from a broad range (between that of the pure conducting polymer and the photoactive material). Conductivity of the buffer layer is changed by processing conditions of the conducting polymer (counter-ion, solvent, concentration etc.) and the composition ratio of the blend. In certain situations the thickness of the buffer layer also affects the spectral response of the photosensor.

[0113] Color Filter Coating

[0114] In some applications, multicolor detection or selected color detection are of interest. These can be achieved by properly selecting the material for the photoactive layer along with coupling the photosensor with a color filter coating.

[0115] One type of application is a photosensor with selected spectral response, for example, from 500 to 600 nm. One effective approach is taking an organic photodiode with low energy cut-off at 600 nm (for example, a photodiode made with MEH-PPV), and placing a long-wavelength, low pass optical filter (with cut-off at 500 nm) in front. The spectral response of semiconducting oligomers and polymers can be controlled by modifying the side chain or main chain structures. For example, by varying the side chain of the PPV system, the optical gap can be tuned from 500 nm to 700 nm. An alternative approach to achieving bandpass selection is to place a bandpass optical filter in front of an organic photodiode with wider spectral response.

[0116] In photoimaging applications, full-color detection is frequently of interest. This can be achieved by splitting a sensor element (pixel) into three subpixels with response to

red (600-700 nm), green (500-600 nm) and blue (400-500 nm) (R, G, B) spectral regions (as shown in **FIG. 4**) respectively, similar to that commonly used in liquid crystal display (LCD) color-display technologies.

[0117] A simple but effective approach to full-color image sensors is sketched in **FIG. 4**. In this approach, the photodiode matrix is made of single sheet of active layer without patterning. The active areas are defined by the row and column electrodes. The spectral response of these organic photodiodes should cover the entire visible region (400-700 nm). Color selection is achieved by the color filter panel in front of the transparent electrodes. There are many organic materials or blends with photoresponse covering the entire visible spectrum. Examples include PT derivatives such as "P3AT"[G. Yu, et al., Phys. Rev. B42, 3004 (1990), "POPT", poly(3-(4-octylphenyl)thiophene) [M. R. Andersson, D. Selese, H. Jarvinen, T. Hjertberg, O. Inganas, O. Wennerstrom and J. E. Osterholm, *Macromolecules* 27, 6503 (1994)], PTV and its derivatives and the like.

[0118] Several color filter techniques have been developed and have been used broadly in color displays made with liquid crystal technologies, including dyeing, pigment-dispersed, printing and electro-deposition [M. Tani and T. Sugiura, *Digest of SID 94* (Orlando, Fla.)]. Another approach uses multilayer dielectric coating based on optical interference. Because of better stability, pigment dispersion has become the major process used in large-scale manufacturing. Color filter panels with designed patterns, often in arrangements in triangular, striped (similar to that shown in **FIG. 4**), or diagonal mosaics, with transparent electrode coating (such as ITO) are existing art and are commercially available to the display industry. This type of substrate can be used in the fabrication of full-color image sensors shown in **FIG. 4**.

[0119] The photodetectors provided by the present invention can be adapted to respond to various types of ionized particles in addition to photons, themselves. This can be accomplished by incorporating in the photodetector structure a scintillating material adapted to emit photons in response to ionized particles. This material can be present in admixture with the active layer, it can be present as a separate layer or it can be present as part of the substrate or the transparent electrode. In one example this scintillating material is a phosphor, present, for example as a phosphor layer.

[0120] Examples of ionized particles which may be detected with devices of this structure are high energy photons, electrons, X-rays and ionized particles are characteristic of X-rays, beta particles and ionized particles are characteristic of gamma radiation.

[0121] Applications of the Invention

[0122] The invention of voltage-switchable organic photodiodes provides the foundation for fabrication of large size, low cost 2D image sensors based on x-y addressable passive diode matrices. This type of photodiode shows high photosensitivity (typically in the range of 30-300 mA/W), quantum efficiency (even over 100% electrons/photon at given reverse biases) and virtually zero response at a bias voltage close to the built-in potential. Thus, a row of pixels in a column-row matrix of such photodiodes can be selected by setting the selected row at reverse bias and the pixels on

the other row biased at a voltage close to the built-in potential. In this way, crosstalk from pixels in different rows is eliminated. The image information at the pixels in the selected row can be read-out correctly in both the serial mode or the parallel mode. The information on the pixels in the other rows can be read-out in sequence or in selected fashion by setting the row of interest to reverse bias. The x-y addressable organic photodiode matrices provide a new type of 2D image sensor which can be made in large size, with low fabrication cost, onto substrates in desired shape or flexible, and hybridizable with other optical or electronic devices.

[0123] Specific advantages of this invention over the prior art include the following:

[0124] (i) Organic photosensors with switchable photosensitivity. High photosensitivity can be switched on (typically in the range of 30-300 mA/W) at a selected reverse biasing voltage. The photosensitivity can be switched off effectively when the diode is biased externally at a voltage closed to that corresponding to the internal potential.

[0125] (ii) 2D, x-y addressable, passive image sensors fabricated with the organic photodiodes with switchable photosensitivity. Crosstalk-free read-out can be achieved with these passive image sensors by means of proper electronic pulse sequences.

[0126] (iii) Multi-color detection and full-color image sensing can be achieved by coupling the image matrix with a color filter panel or by fabricating the image sensor matrix directly onto a color filter panel.

[0127] (iv) Organic photodetector arrays in combination with other known advantages which characterize devices made with organic materials such as soluble conjugated polymers (ease in fabrication into large areas and desired shapes on rigid or flexible substrates, room temperature processing, ease in hybridization with optical, electro-optical, opto-electric or electric devices) offer promise for large size, low cost, high pixel density, 1D or 2D image sensors for use in office automation, in industrial automation, in biomedical devices and in consumer electronics.

## EXAMPLES

### Example 1

[0128] Voltage-switchable photodiodes were fabricated by evaporating a 5000 Å calcium contact (**13**) on the front of a thin MEH-PPV film **12** which was spin-cast from solution onto a ITO/glass substrate **14**. The glass substrate had been previously partially coated with a contact layer **11** of indium-tin-oxide (ITO). The active area of each device was 0.1 cm<sup>2</sup>. The MEH-PPV film was cast from a 0.5% (11 mg/2 ml) xylene solution at room temperature. Details on the synthesis of MEH-PPV can be found in literature [F. Wudl, P. M. Allemand, G. Srdanov, Z. Ni, and D. McBranch, in *Materials for Nonlinear Optics: Chemical Perspectives*, Ed. S. R. Marder, J. E. Sohn and G. D. Stucky (American Chemical Society, Washington, D.C., 1991) p. 683]. The thickness of the active layer was adjusted by varying the concentration of the solution, by varying the spin speed of the spinner head and by applying multiple coating layers.

[0129] Electrical data were obtained with a Keithley 236 Source-Measure Unit. The excitation source was a tungsten-halogen lamp filtered with a bandpass filter (center wavelength of 430 nm, bandwidth of 100 nm) and collimated to form a homogeneous 5 mm×10 mm area of illumination. The maximum optical power at the sample was 20 mW/cm<sup>2</sup> as measured by a calibrated power meter. A set of neutral density filters were used for measurements of intensity dependence.

[0130] FIG. 6 shows the magnitude of the photocurrent (absolute value) as a function of bias voltage under 20 mW/cm<sup>2</sup> illumination at 430 nm. The photocurrent at 1.5 V bias was  $\sim 3 \times 10^{-8}$  A/cm<sup>2</sup>, increasing to  $9 \times 10^{-4}$  A/cm<sup>2</sup> at -10 V reverse bias corresponding to a photosensitivity of 45 mA/W and a quantum efficiency of 13% el/ph. The ratio of the photosensitivity between the two bias voltages was  $3 \times 10^4$ , thus the photosensitivity at 1.5 V bias was practically zero in the read-out circuit. This degree of difference enabled an analog-to-digital (A/D) convertor of 8-12 bit resolution.

[0131] The photoresponse increased nearly linearly with light intensity ( $I^{0.921-1}$ ) over the entire range measured from nW/cm<sup>2</sup> to tens mW/cm<sup>2</sup>. No signature of saturation was observed at 20 mW/cm<sup>2</sup> (the highest light intensity in the measurement).

[0132] Other metals such as Al, In, Cu, Ag and the like were also used for the counterelectrode 13 (see FIG. 1) which is the cathode in these devices. Similar photosensitivities to that shown in FIG. 5 were observed in all these devices. The off-state voltage which balanced off the internal potential of the photodiode varied with the work function of the metal; the off-state voltage is determined by the work function difference between the metal cathode and the ITO anode. Table 1 lists the off-state voltage found for MEH-PPV photodiodes with several metal electrodes.

[0133] This experiment was also repeated with a thin layer (0.5-20 nm) of one of the metals listed in Table 1 with a thick Al layer deposited on top as a current conducting layer. The device performance is similar to that discussed above, with the off-state voltage mainly determined by the thin metal layer at the interface.

[0134] Devices were also fabricated with other photoactive organic materials, including P3AT, POPT, PTV, PPV, BuEH-PPV, BUHP-PPV, C<sub>60</sub>, 6T, 6P, spiro-6P, Alq<sub>3</sub>, anthracene and phthalocyanine. Similar results to those shown in FIG. 6 were observed.

[0135] This example demonstrates that high photosensitivity can be achieved with MEH-PPV organic photodiodes under reverse bias. The desired photosensitivity can be achieved at a given reverse bias. The photosensitivity can be switched off at a proper bias voltage which is dependent on the electrode materials selected. As shown in Table 1, air stable metals with work functions over 4 V can be used for the electrodes in organic photodiodes. This example also demonstrates that the off-state voltage is determined by the work function of the electrode close to the interface area. This example also demonstrates the broad dynamic range of the polymer photodiodes, a dynamic range which is sufficient to enable image detection with multi-grey levels.

TABLE 1

Off-state voltage in ITO/MEH-PPV/metal photodiodes							
Metal cathode	Ca	Sm	Yb	Al	In	Ag	Cu
V <sub>off</sub> (V)	1.5	1.5	1.5	1.1	0.9	0.7	0.4

## Example 2

[0136] Devices of Example 1 were fabricated onto flexible ITO/PET substrates. The thickness of the PET sheets used as substrates was 5-7 mils (125-175  $\mu$ m). Similar device performance was observed.

[0137] This example demonstrates that the voltage-switchable organic photodiodes can be fabricated in a thin structure, in flexible form, or in a desired shape to meet the special needs in specific applications.

## Example 3

[0138] Devices of Example 1 were fabricated on glass and PET substrates. In these devices, the ITO anode 11 was replaced with organic conducting coatings or with ITO overcoated with conducting organic films. PANI-CSA and PEDT/PSS were used as the organic electrode. The PANI-CSA layers were spin-cast from m-cresol solution [details about preparation of the PANI solution and PANI-CSA film have been disclosed in U.S. Pat. No. 5,232,631]. The PEDT-PSS films were cast from an aqueous dispersion (1.3% W/W) which was supplied by Bayer [Bayer trial product, TP AI 4071], details about the synthesis can be found in the literature [G. Heywang and F. Jonas, Adv. Materials 4, 116 (1992)]. The cast films were then baked at 50-85° C. for several hours in a vacuum oven or in a N<sub>2</sub> dry box. In the case of PEDT/PSS, the films were finally baked at a temperature over 100° C. for several minutes to complete the drying process. The thickness of the conducting polymer electrodes was controlled from a few hundred Angstroms to a few thousand Angstroms.

[0139] The optical transmission spectra of the polymer anode electrodes are shown in FIG. 7, including data from PANI-CSA and PEDT-PSS. Also shown in FIG. 7 is the spectral response of the normal human eye, V( $\lambda$ ). The data indicate that these organic conducting electrodes can be used for photosensors for applications in visible spectral range. Moreover, the PEDT-PSS electrodes can also be used for ultraviolet (250-400 nm) and for near infrared. Thus, the polymer electrodes can be used in photosensors with full-color (white color or R, G, B three color) detection.

[0140] In addition to the electrodes made with PANI-CSA or PEDT-PSS alone, devices were fabricated with ITO/PANI-CSA and ITO/PEDT-PSS bilayer electrodes. In these cases, the polymer electrodes were cast in a thin layer (thickness of a few hundred Angstrom units) to maximize the optical transmission. Organic light-emitting devices with bilayer electrodes have demonstrated improved device performance such as carrier injection and device stability. Examples are shown in U.S. patent applications Ser. Nos. 08/205,519 and 08/609,113.

[0141] The photosensitivities of the devices with organic anode electrodes or bilayer electrodes were similar to those

shown in **FIG. 6**; i.e. tens of mA/W at reverse bias voltage in the  $-5$  to about  $-10$  V range.

[0142] This example demonstrates that conducting polymer materials can be used as the transparent electrodes of the photodiodes and image sensors. These plastic electrode materials provide the opportunity to fabricate organic photosensors in flexible or foldable forms. This example also demonstrates that the polymer electrode can be inserted between a metal-oxide transparent electrode (such as ITO) and the active layer to modify the interfacial properties and the device performance.

#### Example 4

[0143] Devices of Example 1 were repeated. A thin buffer layer was inserted between the ITO and the MEH-PPV layers to reduce the leakage current through pinhole imperfections in the active layer. The materials used for the buffer layer were PAZ, TPD (prepared via chemical vapor deposition) and PVK (cast from cyclohexanone solution). The thickness of the buffer layer was 100-500 Å. The photoreponse of these devices was similar to that shown in **FIG. 6**. However, in these devices, the dark current (which is caused frequently from microshorts due to pinholes in the active layer) was reduced in magnitude. In these short-free devices, a photon flux as small as 1 nW/cm<sup>2</sup> was detected under direct current operation. The off-state voltage was 1.6~1.7 V in these devices, slightly higher than in the devices in Example 1.

[0144] This example demonstrates that a buffer layer can be inserted between the active layer and the contact electrode(s) to reduce device shorts and to improve the device response to weak light. This buffer layer can be made of organic molecules via chemical vapor deposition or polymeric materials through wet casting processes.

#### Example 5

[0145] Devices of Example 1 were repeated. The active material, MEH-PPV, was blended with an anionic surfactant Li-CO436 in molar ratios of 0, 1, 5, 10 and 20%. The Li-CO436 was synthesized by a substitution reaction from Alipal CO436 (ammonium salt nonylphenoxy ether sulfate) supplied by Phone-Poulenc Co. [Y. Cao, U.S. patent application Ser. No. 08/888,316]. Al was used as the cathode. The photosensitivity was enhanced in the devices with blended Li-CO436. For example, the photocurrent increased by a factor of 2 in a device made with MEH-PPV:Li-OC436 (10 wt %) compared with a similar device made without the Li-OC436. Moreover, the off-state voltage shifted from 1.1 V in ITO/MEH-PPV/Al devices (see Example 1) to 1.5 V in the ITO/MEH-PPV:Li-OC436 (20%)/Al devices. Similar effects were also observed in devices having an ITO/MEH-PPV/Li-OC436/Al structure. The off-state voltage increases from 1.1 V to 1.6 V.

[0146] Devices of Example 1 were also fabricated with LiF, Li<sub>2</sub>O or BaO layers (1-30 nm) inserted between the MEH-PPV and the Al cathode. Similar enhancement of the short circuit current and the off-state voltage was observed.

[0147] Devices of Example 1 were also fabricated with a TiO<sub>2</sub> layer (1-30 nm) inserted between the MEH-PPV and the Al cathode, and with TiO<sub>2</sub> nanoparticles dispersed in the MEH-PPV film (forming a phase separated MEH-PPV:TiO<sub>2</sub> blend film). Similar results to those obtained with ITO/MEH-PPV/BaO/Al were observed.

[0148] This example demonstrates that organic additives can be added to the active layer or inserted between the active layer and the contact electrode to modify the device performance including photosensitivity and off-state voltage. This example also demonstrates that a layer of inorganic dielectric or semiconducting compounds can be inserted between the active layer and the contact electrode to modify device performance, including photosensitivity and off-state voltage. The inorganic dielectric or semiconducting compounds can also be made in nanoparticle form and blended with the organic photosensing materials.

#### Example 6

[0149] Voltage-switchable photodiodes were fabricated in the structure of ITO/MEH-PPV:PCBM/metal, similar to that shown in **FIG. 1**. The PCBM (a C<sub>60</sub> derivative) served as an acceptor in a donor-acceptor pair with the MEH-PPV acting as donor. The active area of these devices was ~0.1 cm<sup>2</sup>. The blend solution was prepared by mixing 0.8% MEH-PPV and 2% PCBM/xylene solutions with 2:1 weight ratio. The solution was clear, uniform, and was processable at room temperature. Solutions were stored in a N<sub>2</sub> box for over 1.5 years and no aggregation or phase separation were observed. The active layer was spin-cast from the solution at 1000-2000 rpm. Typical film thicknesses were in the range of 1000~2000 Å. Ca, Al, Ag, Cu, and Au were used as the counter electrode **13**. In each case, the film was deposited by vacuum evaporation with thickness of 1000-5000 Å. In another experiment, the concentration of the acceptor PCBM was varied from 0 to 1:1 molecular ratio. Higher on state photosensitivity and lower on-state operation voltage were observed in devices with higher concentrations.

[0150] **FIG. 8** shows the I-V characteristics of an ITO/MEH-PPV:PCBCR/Al device in the dark and under light illumination. The thickness of the blend film was ~2000 Å. The dark current saturated at ~1 nA/cm<sup>2</sup> below 3 V and then increased superlinearly at high bias voltages ( $>E_g/e$ ). Zener tunneling can account for this effect. The photocurrent was measured. The photocurrent at 0.65 V was ~1×10<sup>-7</sup> A/cm<sup>2</sup>, increasing to 5×10<sup>-4</sup> A/cm<sup>2</sup> at -10 V bias. The on-off ratio was ~500. Devices with thinner blend films showed improved photosensitivity and higher on-off ratio. Similar photosensitivity was also observed in devices fabricated with other metals or metal alloys as the counter electrodes. These included Ag, Cu, Ca, Sm, Pb, Mg, LiAl, MgAg, BaAl.

[0151] Other organic molecules were used as the photo-acceptor, including C<sub>60</sub>. Other mixtures were prepared using the C<sub>60</sub> derivative, PCBM with different solvents. Higher photosensitivity was observed from MEH-PPV:PCBM processed from 1,2-dichlorobenzene solution. The photosensitivity reached 0.2 A/W at 430 nm when biased at -2 V.

[0152] This example demonstrates that the photosensitivity can be further improved by blending a donor polymer with a molecular acceptor such as C<sub>60</sub>, PCBM, PCBCR. High photosensitivity can be achieved at relatively low bias and low field (~10<sup>5</sup> V/cm). This example also demonstrates that the photosensitivity can be switched to nearly zero when bias the device at a voltage balancing the internal built-in potential (~0.65 V for Al cathode). The data in this example show that, due to its low dark current level, the polymer photodiode can be used to detect weak light down to intensity level of tens of nW/cm<sup>2</sup>. Thus, the polymer pho-

photodiodes have a dynamic range spanning more than six orders of magnitude, from  $\text{nW/cm}^2$  to  $100 \text{ mW/cm}^2$ .

#### Example 7

[0153] Devices similar to those of Example 6 were fabricated with glass/ITO and PET/ITO substrates in  $4.5 \text{ cm} \times 4 \text{ cm}$  ( $18 \text{ cm}^2$ ) and in  $3.8 \text{ cm} \times 6.4 \text{ cm}$  ( $24.3 \text{ cm}^2$ ) using a fabrication process similar to that of Example 6. I-V characteristics similar to that shown in FIG. 8 were observed. The photodiodes made with flexible PET substrates were bent into circular shapes any without change in their photosensitivity.

[0154] This example demonstrates that the high sensitivity, voltage-switchable photosensors can be fabricated in large sizes. With flexible PET substrates, the photosensors can be bent into desired shapes for special needs in optics, physics and biomedical fields.

#### Example 8

[0155] Devices similar to those of Example 6 were repeated with the active layer made of MEH-PPV:CN-PPV, a polyblend with two polymers as the donor and acceptor phases. Ca and ITO were used as the cathode and anode electrodes, respectively. The molecular ratio between this donor and the acceptor was varied from pure MEH-PPV (1:0) to pure CN-PPV (0:1). Similar I-V characteristics to those shown in FIG. 8 were observed in devices with intermediate molecular ratios. The off-state voltage shifted to  $\sim 1.2 \text{ V}$  as anticipated from the change in the potential barrier between the donor and acceptor phases.

#### Example 9

[0156] Devices similar to those of Example 6 were repeated with the active layer made of sexithiophene (6T):PCBCR, a blend with two organic molecules as the donor and acceptor phases. Similar I-V characteristics were obtained to those shown in FIG. 8.

[0157] Devices were fabricated in the form of ITO/6P/ $\text{C}_{60}$ /Al, ITO/6P/t-Bu-PBD/Al. The photoactive layer comprised two types of organic molecules in heterojunction form, made by thermal evaporation. Similar I-V characteristics to those shown in FIG. 8 were observed.

[0158] Examples 8 and 9 demonstrate that the active layer of the voltage-switchable photodiodes can be organic molecules arranged in bilayer or multilayer structures, a blend of organic molecules, or a blend of conjugated polymers, in addition to a polymer/molecule blend as demonstrated in example 6. The data in these examples along with that in the Example 1 also demonstrate that, for a given cathode such as Ca, the off-state voltage varies with the electronic structure of the active material.

#### Example 10

[0159] Voltage-switchable organic photodiodes was fabricated with P3OT as the active layer in an ITO/P3OT/Au structure. The I-V characteristics in the dark and under light illumination are shown in FIG. 9. Since the work function of Au is higher than ITO, the Au electrode serves as the anode in these devices. Positive bias was defined such that a higher potential was applied to Au electrode. Light was incident from the cathode (ITO) electrode. In this experi-

ment, a He—Ne laser at 633 nm was used as the illumination source with a photon density of  $10 \text{ mW/cm}^2$ .

[0160] The built-in potential in this photodiode was reduced to nearly zero volts. Thus, the off-state of the photodiode was shifted to close to zero volts. The photocurrent at  $-12 \text{ V}$  was  $1 \text{ mA/cm}^2$ , which was  $10^4$  times higher than that at zero bias. Values of the ratio  $I_{\text{ph}}(-12\text{V})/I_{\text{ph}}(0)$  in excess of  $1.5 \times 10^5$  have been realized in similar devices. The photosensitivity at 633 nm was  $\sim 100 \text{ mA/W}$ , corresponding to a quantum efficiency of  $\sim 20\%$  ph/el. The dark current in the test range was below  $5 \times 10^{-7} \text{ A/cm}^2$ . The photocurrent/dark current ratio was greater than 1000 over a broad bias range ( $-4 \sim -12 \text{ V}$ ).

[0161] This example demonstrates that the off-state of the photodiode can be varied by proper selection of the active material and the electrode materials. This voltage can be set to a voltage close to zero volts. A photodiode matrix fabricated with this type of photodiode can be driven by pulse trains with mono-polarity, thus simplifying the driving circuitry. The large on/off switching ratio and the large photocurrent/darkcurrent ratio permit the photodiodes to be used in the fabrication of x-y addressable passive matrices with high pixel density and with multiple-gray levels.

#### Example 11

[0162] Two-dimensional, photodiode matrices were fabricated with seven rows and 40 columns. Pixel size was  $0.7 \text{ mm} \times 0.7 \text{ mm}$ . The space between the row electrodes and the column electrodes was  $1.27 \text{ mm}$  ( $0.05''$ ). The total active area was  $\sim 2'' \times 0.35''$ . Typical I-V characteristics from a pixel are shown in FIG. 10. White light from a fluorescent lamp on the ceiling of the lab was used as the illumination source with intensity of  $\sim$  tens of  $\mu\text{W/cm}^2$ . This is much weaker than the light intensity used in document scanners.

[0163] This example demonstrates that pixelated photodiode matrices can be fabricated without shorts and without crosstalk. This example also demonstrates that these devices can be used for applications with light intensities equal to or much less than a microwatt/ $\text{cm}^2$ . Thus, polymer photodiode matrices are practical for image applications under relatively weak light conditions.

#### Example 12

[0164] A scanning scheme for the photodiode matrix was developed (see FIG. 11). Due to the strong voltage dependence of the photosensitivity, a column of pixels in the 2D photodiode matrix could be selected and turned on with proper voltage bias, leaving the pixels in the adjacent rows insensitive to the incident light. Under such operation, the physical M row, N column 2D matrix is reduced to N isolated M element linear diode arrays which are free from crosstalk between columns. This is reminiscent of the concept that is used in solving a 2D integral by dimension reduction,  $\int \int f(x,y) dx dy = \int g(x) dx \int h(y) dy$ . With such 2D, passive photodiode arrays, an image can be read out with a pulse train scanning through each column of the matrix.

[0165] FIG. 11 shows a instantaneous "snap-shot" of the voltage distribution in a  $7 \times 40$  photodiode matrix. At a specific time t, all the pixels were biased at  $+0.7 \text{ V}$  except the pixels in column 1. The pixels in column 1 were all biased at  $-10 \text{ V}$  so as to achieve high photosensitivity (tens-



hundreds of mA/Watt). The information at each of the pixels in column 1 was read-out in both parallel (with N channel converting circuits and A/D converters) or serial (with N channel analog switches) sequences. Pixels in other columns were selected by switching the column bias from +0.7 V to -10 V in sequence. A digital shift register was used for the column selection.

[0166] To simplify the driver circuit, it was preferable that the photosensor can be switched on and off between 0 V and a reverse bias voltage (-2 to -10 V). Such a mono-polarity, voltage-switchable photodiode was demonstrated with ITO/P3OT/Au, as shown in Example 10.

#### Example 13

[0167] An image of multi-gray levels was selected, the image was scanned with the 7×40 photodiode matrix following the scanning scheme discussed in Example 12. The original image and the readout image were recorded photographically. The readout image reproduced the original image with excellent fidelity.

[0168] This example demonstrates that the voltage-switchable photodiodes can be used as the pixel elements of a column-row matrix (as shown in FIG. 3). The photodiodes at each pixel can be addressed effectively from the column and row electrodes. Image information with multiple gray-levels can be read-out without distortion.

#### Example 14

[0169] Devices similar to those of Example 10 were fabricated and their spectral response was measured at a reverse bias of -15V. The data are shown in FIG. 12. In contrast to the significant sensitivity decrease at short wavelength in conventional inorganic photodiodes, the P3OT photodiodes exhibited relatively flat response for wavelengths shorter than 630 nm; the apparent decrease in sensitivity below 350 nm was mainly due to the transmission cut-off of the ITO coated glass substrate. For -15 V bias, the sensitivity at 540 nm reached 0.35 A/W (a quantum yield of ~80% el/ph), the same value as obtained with UV-enhanced Si diodes. Similar photosensitivity values persisted into the UV region below 400 nm. In some devices, quantum efficiency of over 100% el/ph (140~180% el/ph) was observed under reverse bias.

[0170] Devices were also fabricated in the form of ITO/P3HT/P3HT:PCBM/A1. White light was used as the illumination source. Quantum efficiency of over 100% electrons/photon was observed. The highest value observed was ~1100% electrons/photon. A gain mechanism may play a role in these multilayer devices.

[0171] This example demonstrates high photosensitivity organic photodetectors with response covering, simultaneously, the near UV and the entire visible spectra. This example also demonstrates that organic photodetectors in the metal/organic/metal sandwich structure can have quantum efficiency over 100% electrons/photon; i.e., possesses a gain mechanism.

#### Example 15

[0172] Voltage-switchable photodiodes were fabricated to achieve a response similar to the visual response of the human eye,  $V(\lambda)$ . The devices were fabricated by coating a

long-wavelength-pass filter onto the front panel of the glass substrates of devices, similar to those shown in Example 15. The coating material in this example was a layer of PPV which was converted from its precursor film at 230° C. The photoresponses of the devices with and without the filter are shown in FIG. 13A. The visual response of the human eye,  $V(\lambda)$  (see FIG. 13B), and the transmittance of the PPV optical filter are shown for comparison. The photoresponse of the P3OT diode closely coincided with  $V(\lambda)$  for wavelengths longer than 560 nm, while the optical transmittance of the PPV filter followed  $V(\lambda)$  over a broad range between 450 nm and 550 nm.

[0173] This example demonstrates a polymer photodetector with visual response essentially equivalent to  $V(\lambda)$ , which is of great interest in optical engineering and biophysical/biomedical applications.

#### Example 16

[0174] Solar-blind UV detectors were fabricated with polyblend MEH-PPV:C<sub>60</sub>. ITO and Al were used as anode and cathode materials. The devices were fabricated on an UV bandpass filter purchased from Melles Griot Inc. (product No. 03 FCG 177). FIG. 14 shows the spectral response of the UV detector operating at -2V. The spectral response of the MEH-PPV:C<sub>60</sub> photodiode on ITO/glass substrate and the response of an UV-enhanced Si photodiode are plotted for comparison. The data show that the polymer UV detector was sensitive to UV radiation between 300-400 nm with photosensitivity of ~150 mA/W, comparable to that of UV-enhanced silicon photodiode. The data also show that the photoresponse of the MEH-PPV photodiode was suppressed (over 10<sup>3</sup> times) by the optical bandpass filter.

[0175] This example demonstrates that high sensitivity, solar-blind UV detectors can be fabricated by integrating voltage-switchable organic photodiodes with UV pass optical filters.

#### Example 17

[0176] Example 14 was repeated except that the active layer was a thin PTV layer. The spectral response of a PTV photodiode is shown in FIG. 15A, which covers the range from 300 to 700 nm; i.e., spanning the entire visible range. Selected color detection was achieved by inserting a band-pass filter or a long wavelength filter in front of the detectors. FIG. 15B shows the responses of a blue-color pixel, a green-color pixel and a red-color pixel made with a panel of color filters and an array of PTV photodiodes. The transmittance of the corresponding R, G, B color filters is shown in FIG. 15C.

[0177] This example demonstrates that by coupling the polymer image sensor with a panel of color filters, R, G, B color recognition can be achieved with a panel of polymer photodiode matrix with response covering entire visible spectrum.

#### Example 18

[0178] Red, green and blue (R, G, B) color detection were achieved following the approach shown in FIG. 5. The materials used for the active layers were PPV with a long wavelength cut-off at 500 nm; poly(dihexyloxy phenylene vinylene), "PDHPV", with a long wavelength cut-off at 600

nm; and PTV with long wavelength cut-off at 700 nm. Films were cast from solutions in their precursor forms with thickness between 1000 Å-3000 Å. Conversion to the conjugated forms was carried out at temperatures between 150-230° C. The conjugated films formed in this way were insoluble to organic solvents. Thus, patterning of these materials on a single substrate in dot or strip shapes can be achieved with standard photolithography, screen printing and the like. The normalized photoresponse of these photodiodes is shown in **FIG. 16A**. An ITO/glass substrate was used in this experiment which is optically transparent in visible and opaque in UV.

[0179] Red and green selective color detection were achieved by differentiation of the signals from these photodiodes (this operation can be done in the read-out circuit). The differential responses of these photodiodes are shown in **FIG. 16B**. Red color detection (with response between 600-700 nm) was achieved by subtracting the signal from the PTV photodiode from the signal from the PDHPV photodiode. Green color detection (with response between 500-600 nm) was achieved by subtraction of the PDHPV signal from the PPV signal. The blue color detection was obtained by PPV photodiode directly.

[0180] This example demonstrates that R, G, B selected color detection and full-color image sensors can be achieved by patterning three photosensitive materials on a substrate with uniform optical characteristics.

#### Example 19

[0181] Voltage-switchable photodiodes were fabricated with the conjugated polymer poly(p-phenyl vinylene), PPV as photoactive material. The PPV films were spin-cast onto ITO substrates from a nonconjugated precursor solution and then converted to conjugated form by heating at 200-230° C. for 3 hours. Al was used as the back electrode. The active area was ~0.15 cm<sup>2</sup>. The I-V characteristics of this photodiode in the dark and under illumination are shown in **FIG. 17**. The photocurrent/darkcurrent ratio is in the range of 10<sup>4</sup> for white light illumination of a few mW/cm<sup>2</sup>. Relatively low dark current was observed in forward bias as compared to that observed in photodiodes of, for example, in Example 1. This allows photodetection in both forward bias and reverse bias as shown in **FIG. 17**. The photosensitivity can be switched on and off by varying the external biasing voltage. For example, under white (or UV) light illumination, the photocurrent at +5V or -5V is 2000 times higher than that at +0.95V (or 0.3V).

[0182] This example demonstrates that the photodiode can be switched on by applying a forward bias (beyond the vicinity of the voltage corresponding the off state) or a reverse bias. Photodiodes operable in both switch polarities are useful in certain circuit designs and applications.

#### Example 20

[0183] Voltage-switchable photodetectors were fabricated which had a heterojunction structure as their active layers, they had an ITO/donor layer/acceptor layer/metal structure. The materials used for the donor layer were MEH-PPV and PPV. The material used for the acceptor layer were C<sub>60</sub>, laid down by physical vapor deposition and PCBM and PCBCR laid down by drop casting or spin casting. A data set for a MEH-PPV/C<sub>60</sub> photodiode is shown in **FIG. 18**.

[0184] Multiple junctions were observed in these devices. A build-up potential of ~-0.5V (forward bias was assigned as the positive bias to ITO) was seen in the I-V curve taken in dark. The other junction was revealed when the devices were illuminated. The overall effective barrier is -0.15V (changed sign). The photocurrent/darkcurrent ratio was 10<sup>4</sup> over a broad bias range. Voltage-switchable photosensitivity was seen in both forward and reverse bias. For instance, the on/off ratio of the photocurrent is ~10<sup>3</sup> between +2V and +0.15V bias.

[0185] This example demonstrates that voltage-switchable photodetectors can be fabricated in heterojunction form with two (or more) organic semiconductors with different electronic structures. The photosensitive mode can be achieved in both forward and reverse biases in these devices.

#### Example 21

[0186] Voltage-switchable photosensors was fabricated in the configuration shown in **FIG. 1**. Glass with patterned ITO was used as the substrate. The size of each test pixel was ~0.1 cm<sup>2</sup>. The sensing material used was poly(3-hexyl thiophene), P3HT, which was spin cast at room temperature from a 2.5 wt % solution in toluene. Similar to the spectral response of P3OT (see Example 10), the photoresponse of P3HT sensor covers the entire visible and near UV spectral region such that red, green and blue full-color recognition can be achieved by color filtering techniques.

[0187] **FIG. 19** shows the photo- and dark currents from a P3HT device with 3150 Å film thickness. The data were taken with white light illumination of 8 mW/cm<sup>2</sup> (between 400 nm and 700 nm) and with monochromatic light (600 nm at 1.1 mW/cm<sup>2</sup>). In the dark, the reverse current saturates at low field region and then increases with the biasing voltage, to ~2×10<sup>-5</sup> mA/cm<sup>2</sup> at -25 V bias. The forward current increases exponentially under forward bias (for voltages >1 V), reaching ~1 mA/cm<sup>2</sup> at 3 V bias. The exponential forward current covers more than 5 orders of magnitude in the voltage range from 1-2 V. The rectification ratio at 2 V is over 10<sup>4</sup>. Strong photosensitivity was observed in reverse bias. The photocurrent at -25 V reaches 5.33 mA/cm<sup>2</sup> under 8 mW/cm<sup>2</sup>, white light illumination. This number corresponds to a photoresponsivity of in excess of 0.5 A/W, corresponding to a quantum efficiency larger than 100% electrons/photon. A high I<sub>ph</sub>(V<sub>on</sub>)/I<sub>ph</sub>(V<sub>off</sub>) switching ratio was also achieved in this devices: under 8 mW/cm<sup>2</sup>, I<sub>ph</sub>(-25V)/I<sub>ph</sub>(0.5) is ~4×10<sup>7</sup>. This switching ratio is equal to or even better than the switching ratio of TFT-based photosensors made with inorganic semiconductors (10<sup>4</sup>-10<sup>7</sup>). These organic photodiodes also exhibit a high I<sub>ph</sub>(V)/I<sub>dark</sub>(V) ratio. The I<sub>ph</sub>/I<sub>dark</sub> at -25 V is ~4×10<sup>5</sup> for 8 mW/cm<sup>2</sup> white light illumination, which implies that more than 18 bits (2.6×10<sup>5</sup>) gray levels can be resolved for image applications.

[0188] The high switching ratio implies that for an x-y addressable 2D photodiode matrix of 400×390 pixels (refer to **FIG. 3** of the 2D patent), more than 256 gray levels can be resolved. Adopting quad-matrix design (four sub-matrices arranged in each quadrants), more than 1000×625 pixels are possible with the same resolution. This pixel density is even better than the SVGA standard. The drive circuit for these photodiode matrices is simplified; digital shift registers and BCD digital decoders can be used.

[0189] These photosensors can also be used to fabricate high pixel density linear photodiode arrays. Since only the

pixel at the node contributes to the pixel dark current, there is no restriction on the number of pixels. Hence, the gray level of the sensor array can be as high as  $2^{18}=3\times 10^5$ . These results suggest that the organic photosensor arrays constructed from ITO/P3HT/Al can be used for high quality image sensing. Moreover, the driver circuits for column selection are simplified considerably and digital shift registers or digital decoders can be used directly.

[0190] This example demonstrates an organic photosensor with high switching ratio and high  $I_{ph}/I_{dark}$  ratio. The photosensitivity of such photosensors covers the entire visible spectral range. These sensors are especially suitable for constructing linear photodiode arrays and 2D photodiode matrices for high quality image sensing applications.

#### Example 22

[0191] Linear photodiode arrays were fabricated with 102 sensing elements, each made with P3OT as the semiconducting polymer. Two typical structures of the photodiode arrays are shown in FIG. 20A and FIG. 20B. The pixel size was  $\sim 0.635\text{ mm}\times 0.635\text{ mm}$ . The length of the total sensing area was  $\sim 2.5$ ", longer than any linear photodiode array commercially available. A full-color linear scanner was constructed with a sensing circuit shown in FIG. 21, no analog switching elements (such as field effect transistors) were used in this driver. The read out circuit was digitized into 8 bit with 256 gray levels. Red, green and blue color filters were mounted on a panel and was switched in front of the linear diode array when collecting the corresponding images. The linear photodiode array was mounted on a computer controlled translation stage for the image scanning. A full-color image taken with this scanner is shown in FIG. 22D. It was recovered by a superposition of the red, green and blue color images (FIGS. 22(a, b, c)) taken separately. The image quality was similar to that achieved with a commercial color scanner in the same pixel format (40 dpi) with so-called "multi-million ( $256^3$ ) colors" format.

[0192] Linear photodiode arrays were also fabricated in 40 dpi and 50 dpi forms with total pixels of 200 and 240. The total sensing length is close to 5". The arrays were used for image sensing experiments. Large size ( $5''\times 11''$ ), high quality (8-10 bit), full-color image sensing was demonstrated.

[0193] This example demonstrates that organic photodiode arrays can be used for large size image sensing applications with full-color capability and with multiple gray levels.

#### Example 23

[0194] The linear photodiode arrays demonstrated in Example 22 were also used for visible-blind UV sensing. In this experiment, a visible blocking, UV pass filter was placed in front of the array. The UV image generated with UV ink was projected onto the sensor. The UV image was read out with the organic photodiode array.

[0195] This example demonstrates that visible-blind UV sensors can be achieved with organic photosensors, and that image in UV spectral region can be detected.

#### Example 24

[0196] Linear photodiode arrays were fabricated in the same configuration as that of Example 22 ( $1\times 102$  pixels, 40

pixels/in). One of the sensor arrays was used as an optical beam analyzer to test the optical field distribution a laser beam. The intensity distribution of the testing optical field is shown in FIG. 23. This example demonstrates that the polymer photodiode array can be used to detect spatial distribution of an optical beam. This function is of broad applications in industrial automation.

#### Example 25

[0197] Another  $1\times 102$  linear photodiode array was fabricated on PET substrate (7 mil in thickness). The flexible sensor array was arranged in a semicircular shape. A point light source from a green light emitting diode was placed at the center of the circle, and the angular distribution of the light intensity was tested with the curved sensor array. The result is shown in FIG. 24.

[0198] This example demonstrates that the polymer linear photodiode arrays can be fabricated onto flexible substrates or on curved substrates to fit into an optical apparatus or to probe the spatial distribution of an optical field. The fabrication process and the thin film architecture of the polymer photodiode arrays also allow them to be integrated with electronic drivers on a silicon wafer or integrated with an adapted optical component.

#### Example 26

[0199] A P3OT photodiode array was used as the detector of an UV-visible spectrometer for transmission measurement. The setup is shown in FIG. 25. A transmission spectrum of a thin film of poly(p-phenylene vinylene), PPV, was measured with the polymer linear photodiode arrays. The result is shown in FIG. 26.

[0200] This example demonstrates that the organic photodiode arrays can be used for spectrographic applications.

#### Example 27

[0201] Voltage-switchable photosensors were fabricated in a metal(1)/P3HT/metal(2) sandwich structure. In one case, metal(1) was Au and metal(2) was Al. The thickness of the Au layer was varied from 20 nm to 80 nm and the optical transmission of the Au layer was varied from 50% to  $\sim 1\%$ . The optical reflection of the Au layer varies correspondingly. The thickness of the Al layer was more than 100 nm, so that its reflectance was almost 100%. Such a metal/organic layer/metal structure forms an optical microcavity (optical etalon) device in the spectral region where the optical absorption of the organic layer is relatively low. Such a microcavity structure possesses optical resonance at selected wavelengths. The center wavelength and the bandwidth of the sensing profile can be adjusted by changing the reflection of the metal electrode, by the absorption coefficient, the dielectric constant and the thickness of the organic layer. FIG. 27 shows the spectral response of such device.

[0202] Microcavity devices were also made in the "reverse" structure similar to that shown in FIG. 2; i.e., with light incident onto the free surface electrode (13). The devices were made in both configurations: glass/Au(100 nm)/MEH-PPV/Ag(50 nm) and glass/Ag(100 nm)/MEH-PPV/Au(50 nm). In these devices, Au acts as the anode and Ag as the cathode. Selective spectral response was observed in both structures. These results demonstrate the flexibility

of fabricating the wavelength selective sensors on either transparent substrates or opaque substrates. These results also demonstrate that the devices can be designed so that the light is incident onto either the anode or cathode electrode.

**[0203]** Wavelength selective photosensors were also fabricated with substrates containing an optical stack (sometimes called DBR, Diffractive Bragg Reflector). The transmission of the DBR was ~2%. The photosensors were fabricated as follows: glass/DBR/ITO/MEH-PPV:PCBM/Al. Wavelength selective spectral response was observed with ~2 nm bandwidth.

**[0204]** This example also demonstrates that the organic photosensors can be constructed with wavelength selectivity of narrow bandwidth. Building such a photodiode array or 2D matrix in which each pixel has a different sensing profile forms a flat-panel spectrometer. These kinds of devices have great potential for image sensing, spectrographic, biophysical and biomedical applications.

What is claimed is:

1. A switchable organic photodetector capable of producing a photocurrent in response to light impinging thereupon comprising a photodiode and a variable voltage source,

said photodiode having a built-in potential and comprising:

a first electrode;

a photoactive organic layer disposed on said first electrode; and

a second electrode disposed on said photoactive organic layer; and

said voltage source adapted to selectively apply a switching voltage across said first electrode and said second electrode, said switching voltage imparting a photosensitivity above 1 mA/W at a preselected operating bias and near-zero photosensitivity at a cut-off bias substantially equivalent in magnitude to said built-in potential.

2. A photodiode detector of claim 1 wherein the operating bias is an operating reverse bias.

3. A photodiode detector of claim 1 wherein the operating bias is an operating forward bias.

4. A read-out circuit comprising an organic photodiode detector of claim 1 and means for detecting the photocurrent, wherein the operating bias is in the range of 1-15 V and represents an ON state of the photodiode, said detector having a photosensitivity above 1 mA/Watt in said ON state, and wherein the cut-off bias represents an OFF state of the photodiode equivalent to zero photoresponse at an output of the read-out circuit.

5. The read out circuit of claim 4 wherein the ON and OFF states provide a digital read out.

6. A photodiode array comprising a plurality of photodiode detectors of claim 1 said detectors having their photodiodes arranged in an array, each of said photodiodes being selectively addressable as a pixel of said array.

7. The photodiode array of claim 6, wherein said array comprises at least one row of photodiodes and at least one column of photodiodes, each row having associated therewith a common anode, each column having associated therewith a common cathode, the first electrode of each photodiode of a row being connected to said common anode, the second electrode of each photodiode of a column being

connected to said common cathode, said voltage source adapted to apply said switching voltage across at least one common anode and at least one common cathode to thereby selectively activate at least one pixel of said array.

8. The photodiode array of claim 7, comprising means for applying said switching voltage across a plurality of common anodes and at least one common cathode to thereby selectively activate at least one column of pixels of said array.

9. The photodiode array of claim 7, comprising means for applying said switching voltage across a plurality of common cathodes and at least one common anode to thereby selectively activate at least one row of pixels of said array.

10. A scannable array of voltage-switchable organic photodiodes each having a built-in potential and a predetermined photosensitivity range, said array comprising:

a support substrate;

a first electrode layer comprising at least one linear electrode disposed on said support substrate along a first direction;

a photoactive organic layer disposed on said linear electrode;

a second electrode layer comprising a plurality of linear electrodes disposed on said photoactive layer along a second direction transverse to said first direction; and

a voltage source adapted to apply a switching voltage across at least one electrode of said first electrode layer and at least one electrode of said second electrode layer, said switching voltage thereby imparting to at least one selected photodiode a photosensitivity above 1 mA/W at an operating reverse bias and near-zero photosensitivity at a cut-off bias substantially equivalent in magnitude to said built-in potential.

11. A method of selectively detecting light incident on an array of voltage-switchable organic photodiode detectors, said array comprising a plurality of photodiodes arranged in a row and column matrix, each photodiode having a built in potential and adapted to generate an output in response to incident radiation, each photodiode comprising a first electrode, a photoactive organic layer disposed on said first electrode, and a second electrode disposed on said photoactive layer, the first electrode of each photodiode in a row being electrically connected to a common anode, the second electrode of each photodiode in a column being electrically connected to a common cathode, said method comprising:

sequentially activating a selected column of photodiodes by;

applying an operating bias voltage across the common cathode associated with said selected column and all the common anodes, said operating bias voltage imparting to each photodiode of the selected column a photosensitivity above 1 mA/W;

applying a cut-off voltage across remaining cathodes and all the anodes, said cut-off voltage being equivalent in magnitude to said built-in potential and imparting to the photodiodes of all columns other than the selected column near-zero photosensitivity; and

sequentially reading out the generated output of the selected column of photodiodes.

**12.** A method of selectively detecting light incident on an array of voltage-switchable organic photodiode detectors, said array comprising a plurality of photodiodes arranged in a row and column matrix, each photodiode having a built in potential and adapted to generate an output in response to incident radiation, each photodiode comprising a first electrode, a photoactive organic layer disposed on said first electrode, and a second electrode disposed on said photoactive layer, the first electrode of each photodiode in a row being electrically connected to a common anode, the second electrode of each photodiode in a column being electrically connected to a common cathode, said method comprising:

sequentially activating a selected row of photodiodes by;

applying an operating bias voltage across the common anode associated with said selected row and all the common cathodes, said operating bias voltage imparting to each photodiode of the selected row a photosensitivity above 1 mA/W;

applying a cut-off voltage across remaining anodes and all the cathodes, said cut-off voltage being equivalent in magnitude to said built-in potential and imparting to the photodiodes of all rows other than the selected row near-zero photosensitivity; and

sequentially reading out the generated output of the selected row of photodiodes.

**13.** An organic photodiode detector comprising a photodiode and a voltage source, said photodiode having a built-in potential and a prescribed photosensitivity range in response to incident radiation, said photodiode comprising:

a first electrode;

a photoactive organic layer disposed on said first electrode;

a second electrode disposed on said photoactive organic layer; and

said voltage source adapted to apply an operating biasing voltage across said first electrode and said second electrode, said biasing voltage operating to vary said prescribed photosensitivity range.

**14.** The organic photodiode detector of claim 13, wherein the photosensitivity of said photodiode is above 1 mA/W at an operating bias of said voltage source and is at a near-zero level at a cut-off bias substantially equivalent in magnitude to said built-in potential, said voltage source being switchable between said operating bias and said cut-off bias.

**15.** The organic photodiode detector of claim 13, additionally comprising a support substrate upon which the first electrode is disposed wherein said support substrate and said first electrode are substantially transparent to the incident radiation.

**16.** The organic photodiode detector of claim 13, wherein said photoactive organic layer is comprised of a semiconducting conjugated polymer.

**17.** The organic photodiode detector of claim 16, wherein said semiconducting conjugated polymer is selected from:

poly(phenylenevinylene), and its derivatives;

polythiophene, and its derivatives;

poly(thiophene vinylene), and its derivatives;

polyacetylene, and its derivatives;

polyisothianaphene, and its derivatives;

polypyrrole, and its derivative;

poly(2,5-thienylenevinylene), and its derivatives;

poly(p-phenylene), and its derivatives;

polyfluorene, and its derivatives;

polycarbazole, and its derivatives;

poly(1,6-heptadiyne), and its derivatives;

polyquinolene, and its derivatives; and

polyaniline, and its derivatives.

**18.** The organic photodiode detector of claim 16, wherein said semiconducting conjugated polymer is the donor of a donor/acceptor polyblend, said acceptor being selected from poly(cyanophenylene vinylene), fullerene molecules including C<sub>60</sub> and functional derivatives thereof, PCBM and PCBCR.

**19.** The organic photodiode detector of claim 16 wherein said semiconducting conjugated polymer is the donor of a donor/acceptor polyblend, said acceptor being selected from an organic photoreceptor molecule or an electron transport molecule.

**20.** The organic photodiode detector of claim 13, wherein said photoactive organic layer comprises a material selected from a polymer/polymer polyblend, a polymer/(organic molecule) polyblend, and organic molecules, organometallic molecules, oligomers or molecular blends selected from:

anthracene and its derivatives,

tetracene and its derivatives,

phthalocyanine and its derivatives,

pinacyanol and its derivatives,

fullerene C<sub>60</sub> and its derivatives,

thiophene and its derivatives,

phenylene and its derivatives,

oxadiazole and its derivatives,

PBD and its derivatives,

Alq<sub>3</sub> and other metal-chelate (M-L<sub>3</sub>) type organometallic molecules,

6T/C<sub>60</sub> and blends comprising their derivatives,

6T/pinacyanol and blends comprising their derivatives,

phthalocyanine/o-chloranil and blends comprising their derivatives,

anthracene/C<sub>60</sub> and blends comprising their derivatives, and

anthracene/o-chloranil and blends comprising their derivatives.

**21.** The organic photodiode detector of claim 13, wherein said photoactive organic layer is arranged in a semiconducting heterojunction structure having at least one set of donor and acceptor regions disposed therein.

**22.** The organic photodiode detector of claim 13, wherein said photoactive organic layer comprises optically inert organic additives and/or optically inert inorganic nanoparticles.

**23.** The organic photodiode detector of claim 13, wherein at least one of said first and second electrodes comprises conducting polymer.

**24.** The organic photodiode detector of claim 13, additionally comprising an optical filter layer adapted to restrict transmission of incident radiation to a predetermined wavelength range.

**25.** The organic photodiode detector of claim 24, wherein the predetermined wavelength range is selected to permit a spectral response which follows that of the human eye.

**26.** A photodiode array comprising a plurality of photodiode detectors of claim 13, said detectors having thereon photodiode arranged in an array, each of said photodiodes being selectively addressable as a pixel of said array which said pixels including pixels for detecting radiation in the red range, pixels for detecting radiation in the green range, and pixels for detecting radiation in the blue range.

**27.** The organic photodiode detector of claim 13, additionally comprising a scintillating over layer, said scintillation over layer emitting photons in response to incident high energy ionized particles, said photons being detected by the organic photodetector.

**28.** The organic photodiode detector of claim 27, wherein said ionized particles are selected from high energy photons, electrons, characteristic of X-rays, beta particles and gamma radiation.

**29.** The organic photodiode detector of claim 13, additionally comprising an organic sensing layer that generates mobile electrons and holes in response to incident high energy ionized particles.

**30.** The scannable array of claim 10, wherein the support substrate is made of insulating or semiconducting material and embedded with integrated driving and readout circuits.

**31.** The scannable array of claim 30, wherein the integrated driving circuit comprises a column or row selection circuit.

**32.** The scannable array of claim 30, wherein the readout circuit comprises current integrators or current-voltage converters.

**33.** The photodiode array of claim 7, additionally comprising a coating of black matrix in the space between the pixels.

**34.** The organic photodetector of claim 13, additionally comprising an optical mirror placed to form a microcavity optical etalon device which possesses selective response at resonant wavelengths.

**35.** The organic photodetector of claim 13, additionally comprising two optical mirrors placed outside to form a microcavity device (optical etalon) which possesses selective response at resonant wavelengths.

**36.** The organic photodetector of claim 13, wherein a buffer layer is inserted between an electrode and the photoactive organic layer.

**37.** The organic photodetector arrays of claim 7, wherein the switching voltage varies among pixels so that inhomogeneity of photosensitivity can be compensated with external bias.

**38.** The organic photodetector array of claim 7, wherein the switching voltage varies among pixels following a defined pattern so that a sensing array with designed photosensitivity pattern is achieved for specific applications such as image procession.

\* \* \* \* \*