



(19) **United States**

(12) **Patent Application Publication**

**Rayssiguier et al.**

(10) **Pub. No.: US 2002/0000317 A1**

(43) **Pub. Date:**

**Jan. 3, 2002**

(54) **COMMUNICATING WITH DEVICES POSITIONED OUTSIDE A LINER IN A WELLBORE**

(52) **U.S. Cl.** ..... **166/285; 166/380; 166/65.1; 166/177.4; 166/242.6; 166/242.8**

(76) **Inventors:** **Christophe M. Rayssiguier**, Houston, TX (US); **Michael R. Johnson**, Sugar Land, TX (US); **Ronald E. Pringle**, Houston, TX (US); **John A. Booker**, Missouri City, TX (US); **Alexandre G.E. Kosmala**, Houston, TX (US)

(57) **ABSTRACT**

A downhole string includes a liner and devices positioned outside the liner. One or more control lines extend from the liner devices along the exterior of the liner to one or more connectors that provide connection points inside the liner. The one or more connectors may include electrical connectors (e.g., direct contact connectors), inductive connectors (e.g., inductive couplers), optical connectors (e.g., fiber optic connectors), and hydraulic connectors. The one or more control lines may be electrical lines, fiber optic lines, or hydraulic lines. The downhole string may also be used with a cement protector during cementing operations to protect both the inside of the liner as well as the one or more connectors attached to the liner. The cement protector includes a sleeve that isolates cement from the inside of the liner during a cementing operation so that a liner wiper plug is not needed. The cement protector is engageable to a pulling tool that is attached to a running tool. The running tool in turn is connected to a pipe through which a cement slurry can be pumped. The cement slurry pumped through the inner bore of the pipe enters the sleeve of the cement protector. One or more ports are provided in the cement protector sleeve to enable communication of the cement slurry to an annulus region between the outer wall of the liner and the inner wall of the wellbore. If the apparatus and method is used with a casing, then a running tool may be omitted.

Correspondence Address:  
**Schlumberger Reservoir Completions / Schlumberger Technology Corporation**  
14910 Airline Road  
P.O. Box 1590  
Rosharon, TX 77583-1590 (US)

(21) **Appl. No.:** **09/934,734**

(22) **Filed:** **Aug. 22, 2001**

**Related U.S. Application Data**

(62) Division of application No. 09/528,334, filed on Mar. 17, 2000, now Pat. No. 6,302,203.

**Publication Classification**

(51) **Int. Cl.<sup>7</sup>** ..... **E21B 33/00; E21B 19/16**

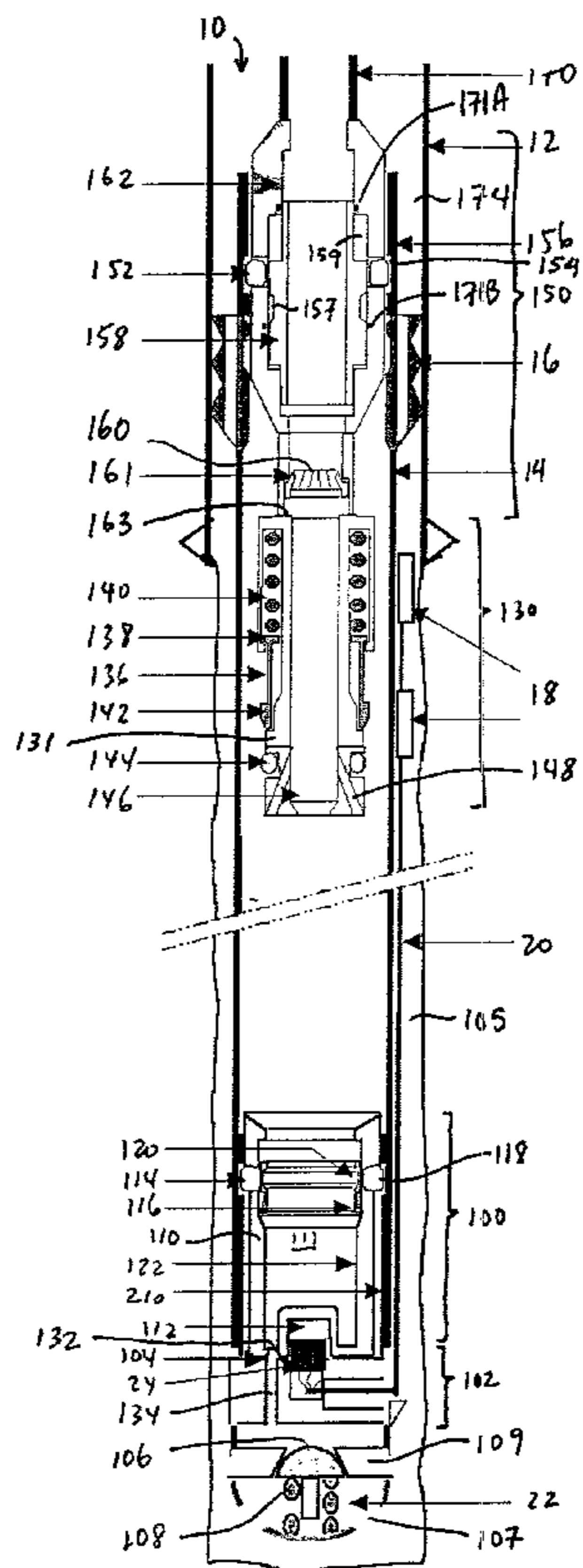

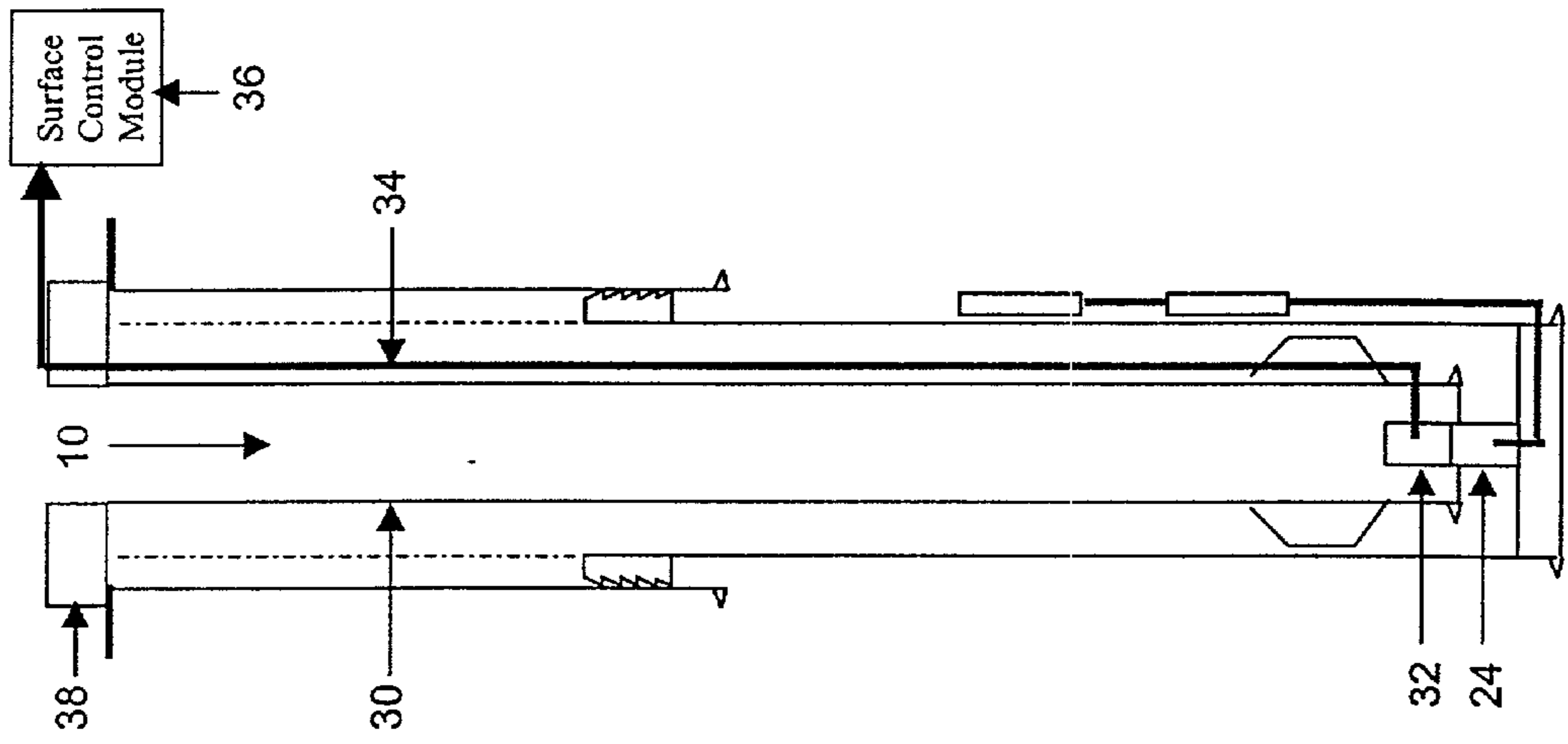

FIG. 2A

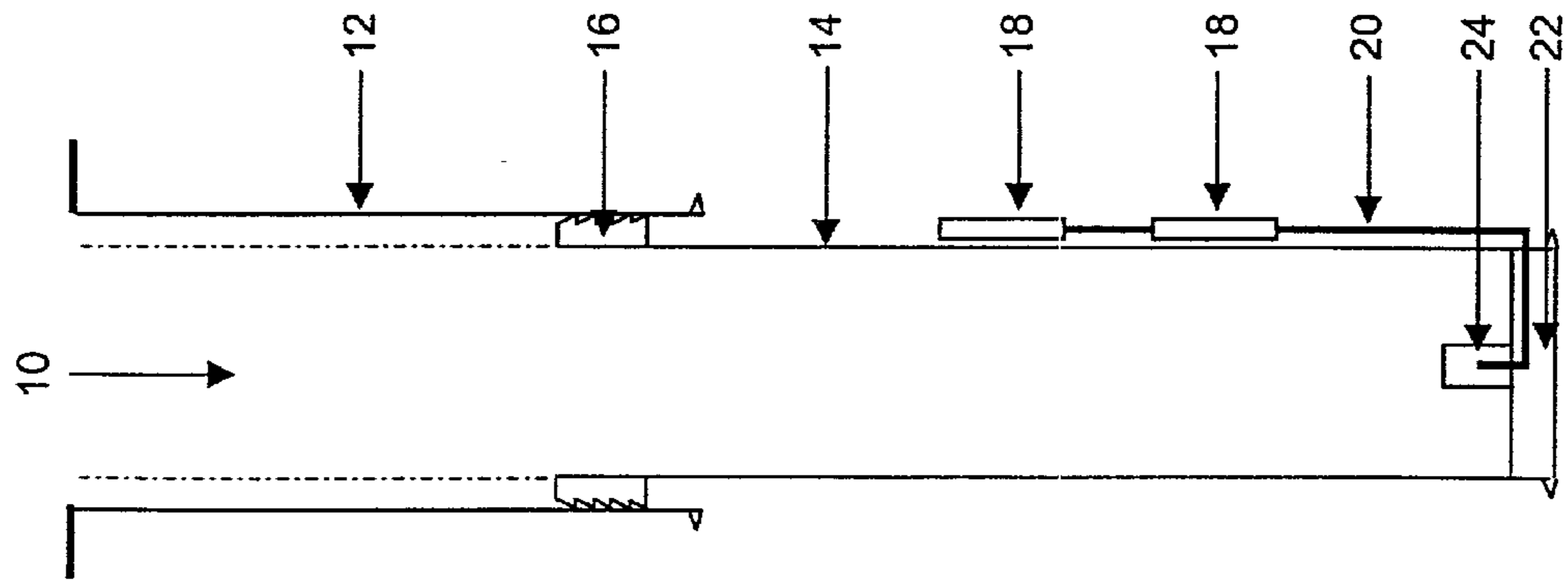

FIG. 1

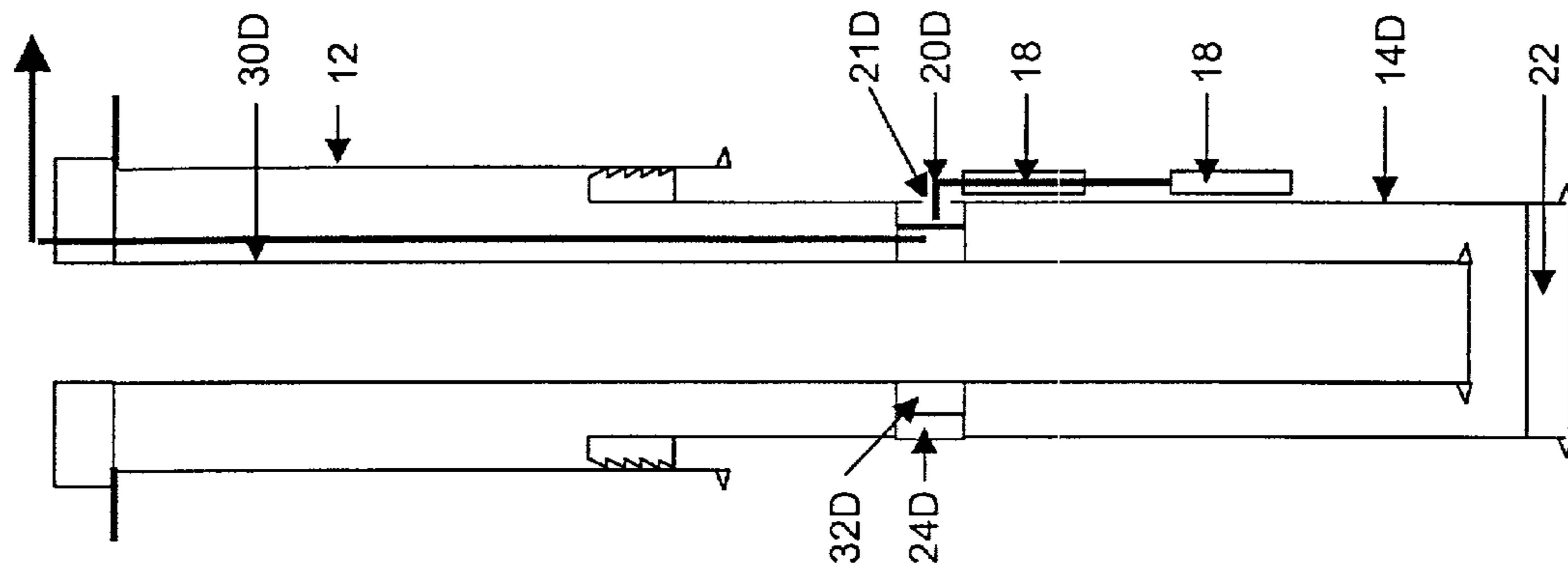

FIG. 2D

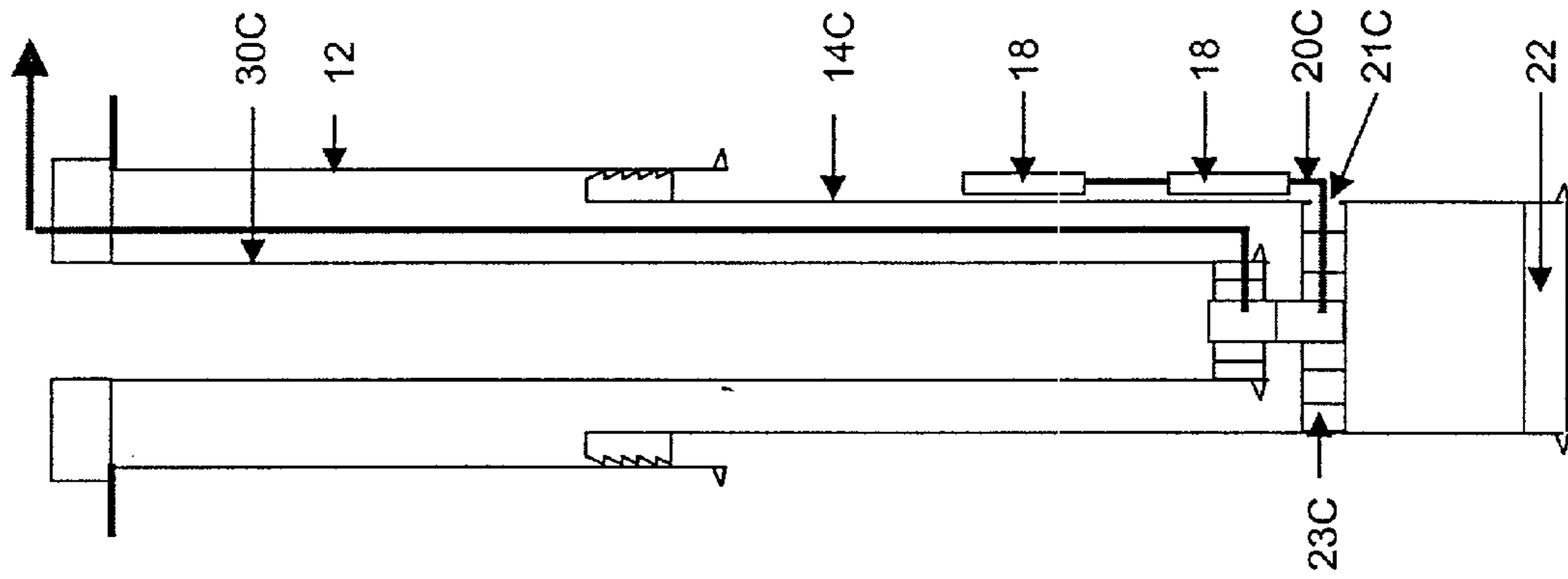

FIG. 2C

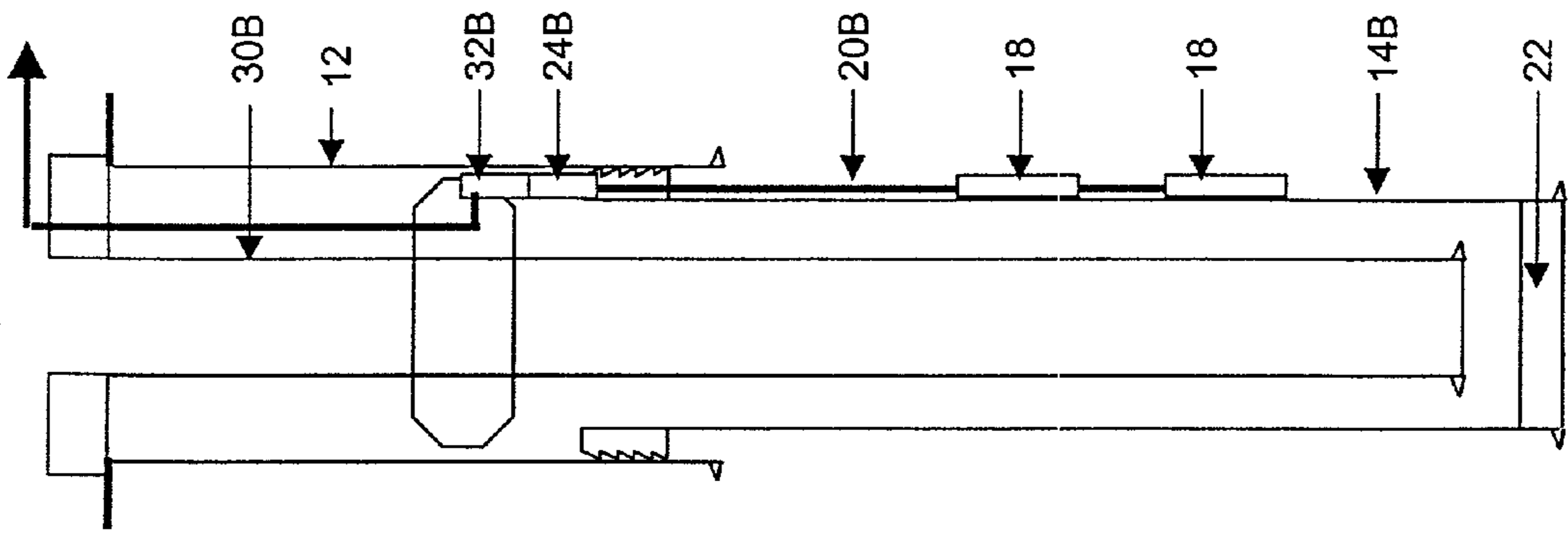

FIG. 2B

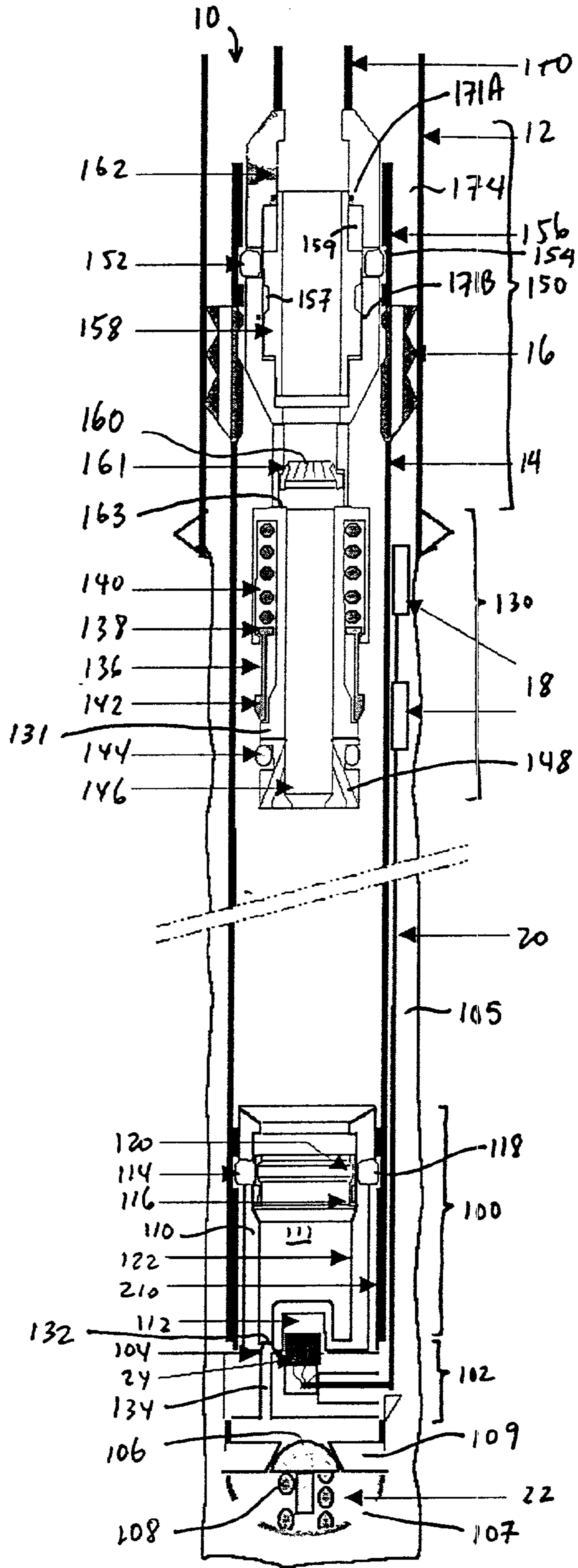
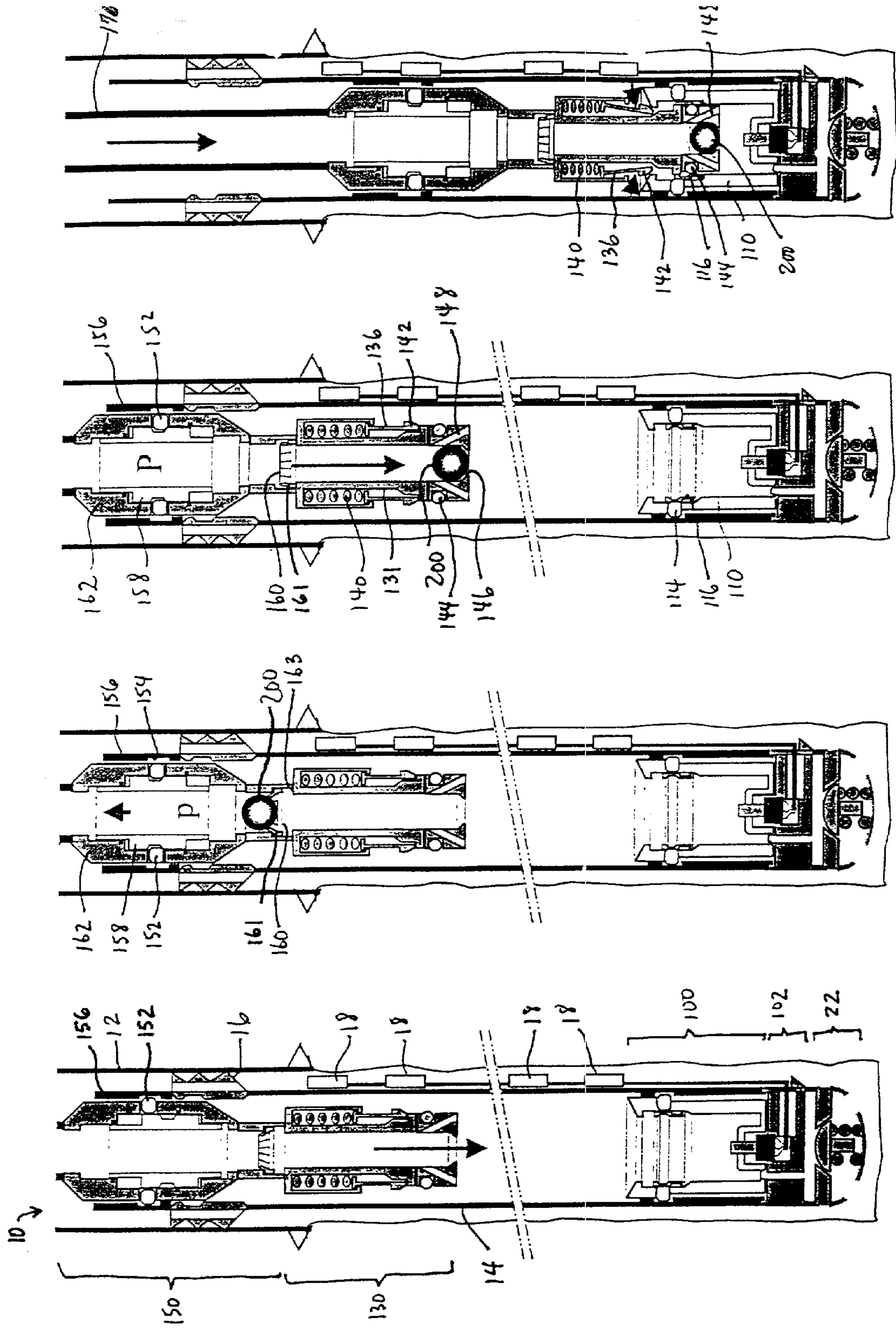

FIG. 3



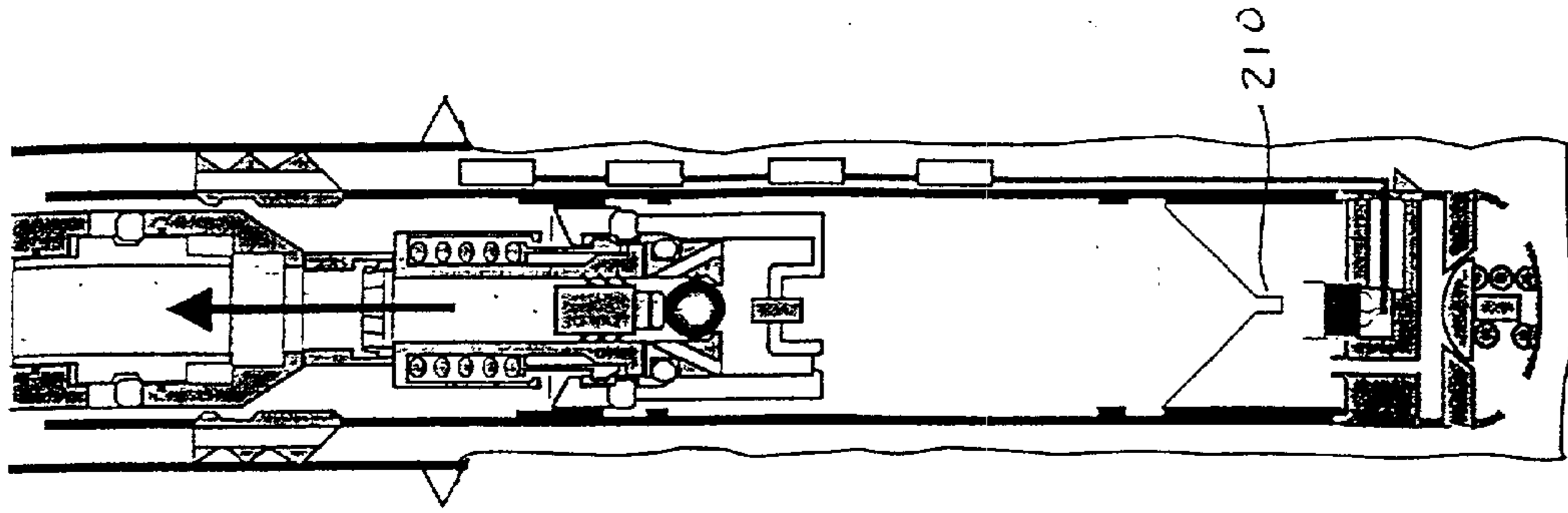

FIG. 4H

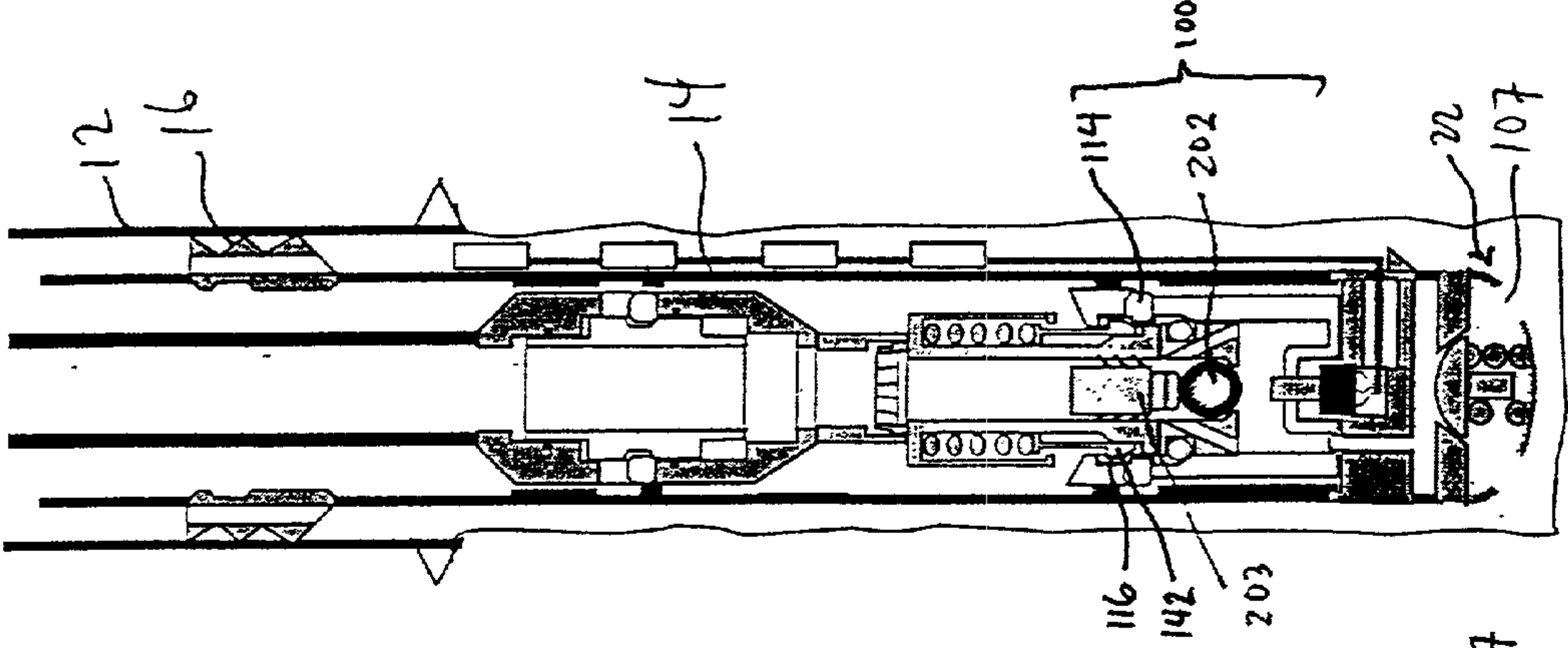

FIG. 4G

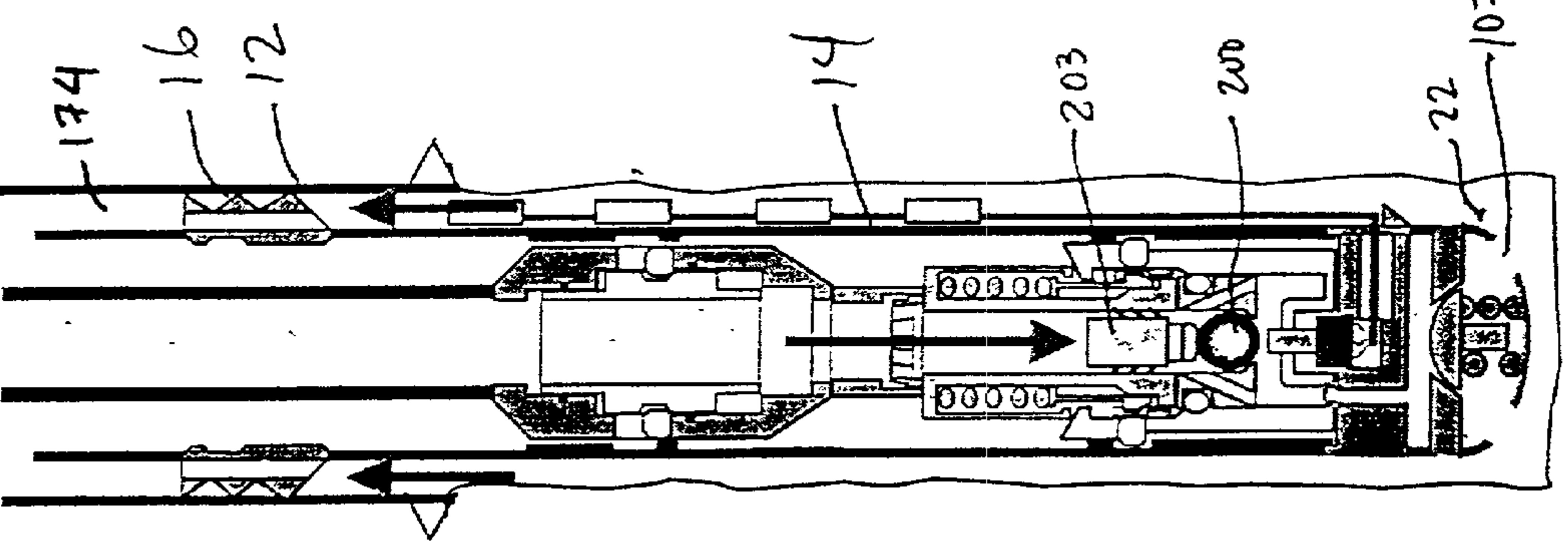

FIG. 4F

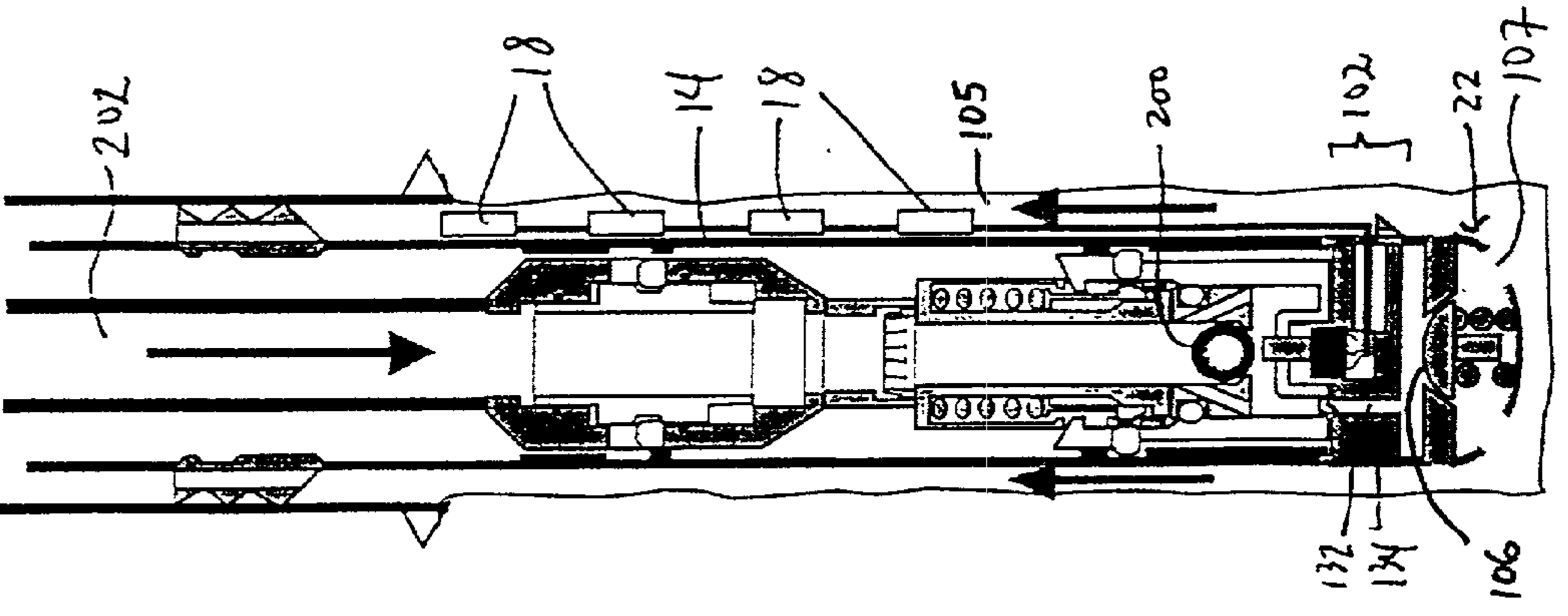

FIG. 4E

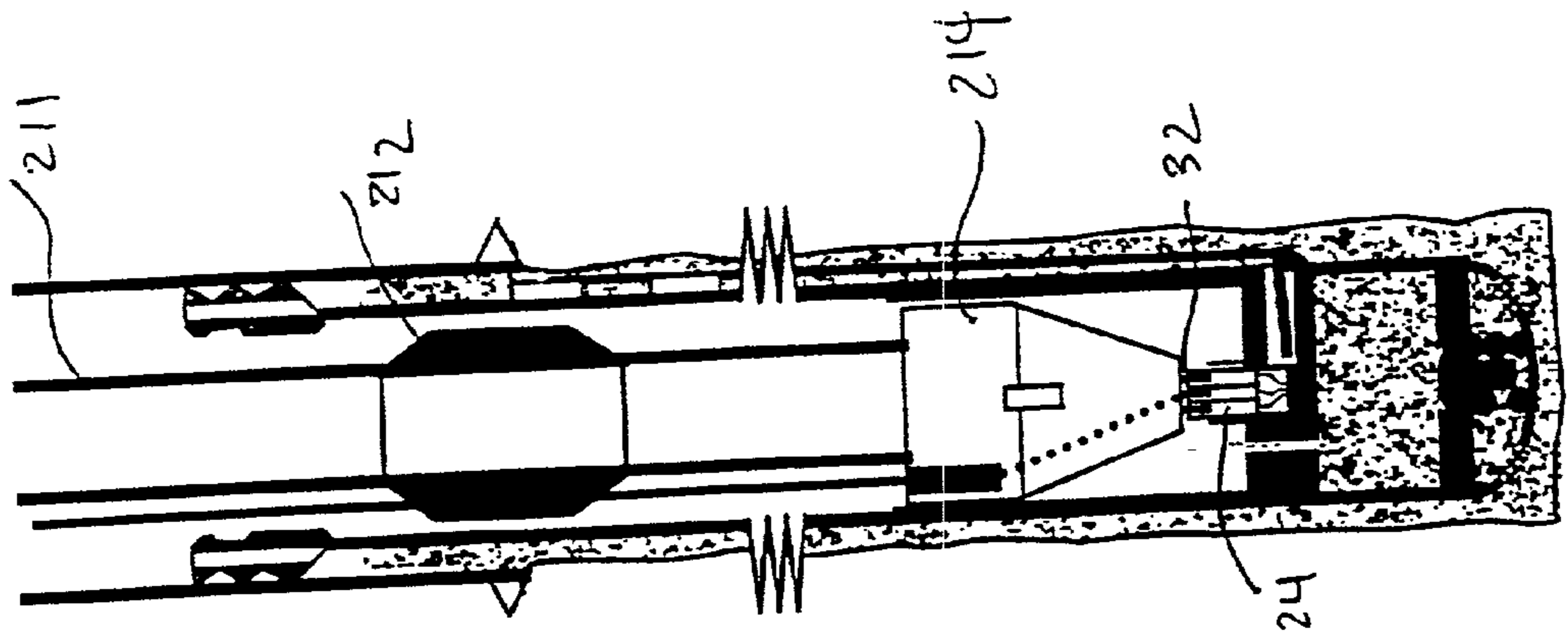

FIG. 4I

## COMMUNICATING WITH DEVICES POSITIONED OUTSIDE A LINER IN A WELLBORE

### BACKGROUND

[0001] The invention relates to communicating with devices positioned outside a liner in a wellbore.

[0002] Oil and gas wells may be completed with a variety of downhole devices to produce hydrocarbons from, or inject fluids into, formations beneath the earth surface. Completion equipment have been developed for many types of wells, including vertical or near-vertical, horizontal, deviated, and multilateral wells. Typical completion equipment include valves, tubing, packers, and other downhole devices, as well as electrical, optical, or hydraulic devices to monitor downhole conditions and to control actuation of downhole devices (e.g., opening or closing valves, setting packers, and so forth).

[0003] Sensors and control devices may also be mounted on or positioned outside of a liner, which is typically cemented to the wall of the wellbore. A special type of liner includes casing, which is a liner that extends to the well surface. A liner may also be connected below a casing to extend further into the wellbore or into a lateral branch of a multilateral well. One type of sensor that may be mounted on the outside of a casing includes resistivity electrodes, which are used to monitor the resistivity of a surrounding formation reservoir. Based on the resistivity information, various characteristics of the formation may be determined.

[0004] A conventional technique of communicating with the sensors mounted on the outside of casing includes running a control line outside the casing to the well surface. However, running one or more control lines in the cement layer creates a potential leak path to the well surface, which is undesirable. In addition, for liners that do not extend to the well surface, use of this technique may not be available. Another drawback of running a control line on the outside of the casing is that the control line may have to cross wellhead equipment at a relatively inconvenient location.

[0005] A need thus exists for a mechanism to provide Communication with downhole sensors or control devices that are positioned outside of liners in a wellbore.

### SUMMARY

[0006] In general, according to one embodiment, an apparatus for use in a well having a well surface and a wellbore lined with a liner includes one or more devices positioned outside the liner and one or more control lines connected to the devices and extending outside of the liner. One or more connectors are connected to the control lines and provide one or more connecting points accessible from inside the liner below the well surface.

[0007] Other embodiments and features will become apparent from the following description, from the drawings, and from the claims.

### BRIEF DESCRIPTION OF THE DRAWINGS

[0008] FIG. 1 illustrates an embodiment of a liner string in a wellbore, the liner string including a liner, devices positioned outside the liner, a control line connected to the devices, and a connector connected to the control line.

[0009] FIG. 2A illustrates an embodiment of a completion string for use with the liner string of FIG. 1, the completion string including a connector adapted to be mated to the liner string connector.

[0010] FIGS. 2B-2D illustrate other arrangements of liner strings and completion strings.

[0011] FIG. 3 illustrates an embodiment of a string cooperable with the liner string of FIG. 1 to perform cementing operations in accordance with an embodiment.

[0012] FIGS. 4A-4I illustrate a sequence of operations involving the string of FIG. 3, the liner string of FIG. 1, and a completion string.

### DETAILED DESCRIPTION

[0013] In the following description, numerous details are set forth to provide an understanding of the present invention. However, it will be understood by those skilled in the art that the present invention may be practiced without these details and that numerous variations or modifications from the described embodiments may be possible.

[0014] As used here, a "liner" refers to any structure used to line the wall of any section of a wellbore, either in the main bore or in a lateral branch. Thus, "liner" may refer to either a liner or casing, which extends to the well surface.

[0015] As used here, the terms "up" and "down"; "upper" and "lower"; "upwardly" and "downwardly"; and other like terms indicating relative positions above or below a given point or element are used in this description to more clearly described some embodiments of the invention. However, when applied to equipment and methods for use in wells that are deviated or horizontal, such terms may refer to a left to right, right to left, or other relationship as appropriate. Also, when used in a horizontal section of a wellbore, the terms "below" and "deeper" refer to a direction of the wellbore that is more distal from the wellbore surface.

[0016] Referring to FIG. 1, a liner string according to one embodiment in a wellbore 10 is illustrated. An upper segment of the wellbore 10 is lined with casing 12. The liner string includes a liner 14 that lines a lower segment of the wellbore 10, with the liner 14 attached below a liner hanger 16 engaged to the inner wall of the casing 12. One or more control and/or monitoring devices 18 may be positioned outside the outer wall of the liner 14. In one arrangement, the control and/or monitoring devices may be mounted or attached to the outer wall of the liner 14. In another arrangement, the control and/or monitoring devices may be positioned outside the liner 14 but not in contact with the liner outer wall.

[0017] Such control and/or monitoring devices may include sensors (such as pressure and temperature gauges, resistivity electrodes, and so forth) to monitor wellbore or formation characteristics, and control elements (such as microcontrollers, microprocessors, or other electronic circuitry) to perform various control operations, such as opening valves, turning on or off sensors, and so forth. More generally, such control and/or monitoring devices may be referred to as "liner devices," which are downhole devices positioned or mounted outside of a liner. The liner devices may be electrical, hydraulic, optical, or other types of devices. One example of a liner device includes an array of



resistivity electrodes that are used to create a resistive image of the surrounding formation reservoir to predict the arrival of water during production. In a different embodiment, the liner devices may be positioned outside the casing **12** instead of the liner **14**.

[0018] In accordance with some embodiments, a control line **20** (or plural control lines) is connected to the liner devices **18**. As illustrated, the control line **20** extends below the liner devices **18** deeper (or more distally) into the wellbore to the lower end of the liner **14**. The control line **20** extends along the outside of the liner **14** and may be secured to the liner with protectors (usually at every coupling). At the lower end, a special liner shoe **22** is attached to the liner **14**, with the control line **20** extending through the shoe **22**. The shoe **22** may be connected to (or in the proximity of) a connector sub that includes a connector **24** (or plural connectors) connected to the control line **20**. The combination of the connector sub and connector **24** is one example of a communication connector assembly. The connector assembly is accessible from within the liner **14**. The connector **24** may be an electrical connector (e.g., a direct contact connector), an inductive coupler, an optical connector (e.g., a fiber optic connector), a hydraulic connector, or other connector. The control line **20** may be an electrical line, a fiber optic line, a hydraulic line, or other control line. The control line **20** is adapted to carry both telemetry and power signals.

[0019] In other arrangement, the connector does not need to be positioned at or in the proximity of the lower end of the liner **14** but may be positioned at another location along the liner. However, in such other arrangements, the connector is still positioned at a depth below the well surface so that the control line running from the liner devices to the connector does not compromise the seal provided by the cement layer surrounding the liner. Thus, a benefit offered by any arrangement in which the connector **24** is positioned below the well surface is that a connection mechanism to the liner devices is made available without having to run a control line in the cement layer all the way to the well surface, which may create an undesirable leak path. Also, this avoids having to run a control line through the liner hanger **16**. Further, in the arrangement of **FIG. 1**, another benefit of positioning the connector **24** at or near the proximity of the lower end of the liner **14** is to avoid creating an obstruction in the inner bore of the liner **14** when other tool strings are run downhole. In the arrangements discussed, the connector **24** is positioned so that it can mate with a corresponding connector or other component run into the inner bore of the liner **14**.

[0020] To install the liner string shown in **FIG. 1** after the casing **12** has been installed in the wellbore **10**, the liner string (including the liner **14**, liner hanger **16**, shoe **22**, connector **24**, control line **20**, and liner devices **18**) is run into the wellbore to the desired depth. Once positioned in the desired depth, the liner **14** is cemented in place. The cement is pumped (in slurry form) into the inner bore of the liner **14** and through the shoe **22** at the lower end to introduce the cement slurry into the annulus region between the outside of the liner and the inner wall of the wellbore **10**. The introduced cement slurry flows upwardly in the annulus region to form the cement layer. The cement slurry is also flowed into a region **31** where the liner **14** and casing **12** overlap. Due to the absence of a control line running between the liner **14** and the casing **12**, the cement in the region **31** between the liner **14** and the casing **12** provides a good seal to prevent

wellbore fluids from leaking through the annulus between the outer wall of the liner **14** and the inner wall of the casing **12**.

[0021] Referring to **FIG. 2A**, a completion string is run into the wellbore **10** after the liner string has been installed. In one example embodiment, the completion string includes a tubing **30**, e.g., a production tubing, an injection tubing, or some other type of pipe. A connector **32** (or plural connectors) may be mounted at the lower end of the tubing **30**. The connector **32** is adapted to connect to the connector **24** included in the connector sub of the liner string. The connector **32** may be an electrical, inductive, optical, hydraulic, or other connector.

[0022] The tubing connector **32** is in turn connected to a control line **34** (or plural control lines), which may be an electrical, optical, hydraulic, or other control line. The control line **34** runs along the outside of the tubing **30** to the well surface. In one arrangement, the control line **34** may be secured to the tubing **30** with protectors (usually at every coupling). At the well surface, the control line **32** extends through a tubing hanger **38** to a surface control module **36**. The surface control module **36** may be a power supply and computer for electrical control lines, an optical sensor for fiber optic control lines, a hydraulic console for a hydraulic control line **24**, another type of module, or a combination of the different consoles.

[0023] Centralizer mechanisms may be used to orient the connector **32** with respect to the liner connector **24** to help mate the connectors. If plural connectors are arranged in parallel, an orientation profile may be placed on the liner **14** above the liner connectors **24** so that a pin located on the tubing can orient the production string and position its connectors **32** to line up with the liner connectors **24**.

[0024] **FIGS. 2B-2D** illustrate different arrangements of the liner string and completion string. In the **FIG. 2B** example, a control line **20B** extends outside the liner **14** to the upper end of the liner. At the upper end, the control line **20B** reaches a connector sub **24B**. The connector **24B** is attached to the liner **14B** and may be mated with the connector **32B** of the tubing **30B**.

[0025] Referring to **FIG. 2C**, in yet another arrangement, the control line **20C** extends from the devices **18**. In the example shown, the control line **20C** extends through an opening **21C** in the liner **14C**. The control line **20C** is then connected to a connector sub **23C** inside the liner **14C**. In another arrangement, the control line **20C** may extend above the devices **18** instead of below the devices.

[0026] Referring to **FIG. 2D**, another arrangement has a control line **20D** extending to an opening **21D** in the liner **14D**. The control line **20D** is provided through the opening **21D** to an annular connector **24D** inside the liner **14D**. The tubing **30D** is attached to an annular connector **32D** that is capable of mating with the connector **24D**.

[0027] Other arrangements are also possible. For example, the connector on **FIG. 2D** may be placed on one side of the liner.

[0028] In accordance with a further embodiment of the invention, a cement protector may be used to protect the inner wall of the liner **14** during cementing operations. After the liner string is lowered to a desired depth, the liner **14**

needs to be cemented to the wellbore wall. Conventionally, in performing a cementing operation, a cement slurry may be flowed inside the liner 14. To remove the cement from the inner bore of the liner 14 after the cementing operation has completed, a wiper plug may be used to wipe out the cement. The presence of the liner connector 24 may be incompatible with the use of cement or a wiper plug. The cement inside the inner bore or subsequent use of the wiper plug may also damage the connector 24.

[0029] The cement protector in accordance with some embodiments may be used to isolate the cement from the inner wall of the liner 14 and the connector 24 during a cementing operation. This reduces the likelihood that Connector 24 and the inner wall of the liner are damaged during the cementing operation.

[0030] By not polluting the inside of the liner with cement, use of a wiper plug can be avoided, which can reduce the number of runs needed to perform a cementing operation to as little as a single run. A safe operation is provided since the cement protector may be retrieved to the well surface before the cement dries. In an alternative arrangement, the cement protector may be a cover that isolates cement from the connector 24 but not necessarily the liner 14.

[0031] Referring to FIG. 3, a tool string that includes a cement protector 100 in accordance with one embodiment is illustrated. The liner string shown in FIG. 1 including the casing 12, liner hanger 16, liner 14, connector(s) 24, liner shoe 22, control line(s) 20, and liner devices 18, is also illustrated in FIG. 3. The cement protector 100 is positioned above a connector sub 102 that includes the connector(s) 24. The connector sub 102 is located above the liner shoe 22, which includes a check valve 106 that is pushed by a spring 108 to an upward and sealed position against a seat member 109. Plural check valves may be used for redundancy. During cementing operations, a cement slurry applied under pressure pushes the check valve 106 away from the seat member 109 to allow the cement slurry to flow through openings 107 into an annulus region 105 between the outside of the liner 14 and the inner wall of the wellbore 10.

[0032] The cement protector 100 includes a sleeve 110 with an inner bore 111. The bottom of the cement protector 100 provides a cover or cap that defines a chamber 112 which may be filled with a clean fluid such as grease or dielectric oil to protect the connector(s) 24 from pollution by cement or debris.

[0033] One or more ports 132 are provided at the lower end of the cement protector sleeve 110 to allow outflow of cement slurry from the inner bore 111 of the cement protector sleeve 110. One or more corresponding conduits 134 are provided in the connector sub 134. The one or more fluid flow paths provided by the one or more ports 132 and the one or more conduits 134 enable the communication of cement slurry to the shoe 22. Seals 104 may be provided around the one or more ports 132 and conduits 134 to prevent communication of cement slurry with any part of the inner bore of the liner 14.

[0034] The cement protector 100 also includes a locking device that includes locking dogs 114 and a locking sleeve 116. The locking device releasably engages the cement protector 100 to the liner 14. The locking dogs 114 are positioned in corresponding windows in the cement protec-

tor sleeve 110. A shearing mechanism (not shown) may be used to fix the locking sleeve 116 in place until a sufficient force is applied to move the locking sleeve 116 upwardly to release the locking dogs 114. This translation opens a bypass orifice (not shown) cut into the protector sleeve 110, so that any differential pressure can be equalized before removing the cement protector 100. In the illustrated position of FIG. 3, the locking dogs 114 are held in position by the locking sleeve 116 inside a groove 118 formed in the inner wall of the liner 14.

[0035] A recess 120 is provided in the locking sleeve 116. The recess 120 is adapted to engage a pulling tool 130 so that the cement protector 100 may be retrieved from the wellbore after the cementing operation is complete. The cement protector 100 also includes a seal bore 122 that allows the pulling tool 130 to sealingly engage the inner bore of the cement protector sleeve 110.

[0036] The pulling tool 130 includes elements to engage corresponding elements of the cement protector 100 so that upward movement of the pulling tool 130 pulls the cement protector 100 upwardly. The lower end of the pulling tool 130 includes a seat 146 for a ball that may be dropped from the well surface. In addition, one or more angled conduits 148 are provided in the housing 131 of the pulling tool 130 to enable communication between the inside of the pulling tool 130 and the outside when the ball is positioned in the seat 146. A groove is also formed in the pulling tool housing 131 to carry a seal 144, which may be an O-ring or V-packing seal assembly, that is adapted to engage the seal bore 122 of the cement protector 100.

[0037] Fingers 136 are provided on the outside of the pulling tool 130. The lower ends of the fingers 136 include protruding portions 142. The combination of each finger 136 and protruding portion 142 forms a collet. In the illustrated position, the inner surfaces of the protruding portions 142 abut on the pulling tool housing 131. The upper end 138 of the fingers 136 are engaged to a coiled spring 140. The coiled spring 140 is contained inside a chamber defined by the pulling tool housing 131.

[0038] An upward force applied on the fingers 136 may move the fingers 136 upwardly against the spring 140. When the protruding portions 142 have moved up a sufficient distance to a recessed section of the pulling tool housing 131, the protruding portions 142 may be collapsed radially inwardly. The ability to collapse the protruding portions 142 enable the protruding portions 142 to engage the recess 120 of the locking sleeve 116 in the cement protector 100.

[0039] As an option, the pulling tool body 110 may be equipped with spring-energized keys (not shown). These keys can expand into slots cut into the top of the orienting profile 210. In this way, a torque applied to the running string at the surface can be transmitted to the liner, if desired.

[0040] Attached above the pulling tool 130 is a running tool 150. The running tool 150 is attached below a tubing or pipe 170 and includes a mechanism for releasably securing the running tool 150 to the liner 14. Collectively, the pipe 170, running tool 150, and pulling tool 130 make up an example of a running string. The running tool 150 is adapted to be released once the liner hanger 16 is engaged to the casing 12. Effectively, the running string is releasably attached proximal an upper end of the liner 14 when the liner string is being run in.

[0041] The running tool **150** includes dogs **152** that are fitted through openings in the running tool housing **162** to engage slots **154** formed in a nipple **156** connected to the liner hanger **16**. Torque can be applied to the running string for transmission to the liner if needed. The dogs **152** are maintained in position by a locking sleeve **158** in the running tool **150**. The locking sleeve **158** is capable of translating longitudinally inside the running tool housing, but is fixed in position by a shearing mechanism (not shown).

[0042] The running tool **150** also provides a seat **160** for a ball that can be dropped from the well surface. The ball sealingly engages the seat **160** so that pressure may be increased inside the running tool **150** above the ball. This pressure increase creates a differential pressure across the locking sleeve **158**, which is equipped with two different seals **171A** and **171B** on the two sides of a chamber **159**. If a sufficient force is applied by the differential pressure, the shearing mechanism of the locking sleeve **158** breaks to allow translation of the locking sleeve **158** to free the dogs **152** into the sleeve groove **157**.

[0043] The ball seat itself **160** may be locked in position by a shearing mechanism (not shown) having a larger shear strength than the locking sleeve **158** shearing mechanism. Once a sufficient force is applied to shear the shearing mechanism of the ball seat **160**, the ball seat **160** can be moved downwardly until it impacts an inner shoulder **163** of the pulling tool housing **131**. At this point, the force applied against the ball can push the upper ring **161** of the ball seat **160** outwardly so that the ball **200** can pass through the ball seat **160**. Then the ball **200** drops into the pulling tool **130** to sit in the seat **146**, pushed by the differential pressure. In another embodiment, the two seats **161** and **146** can be combined. The seat **146** in this other embodiment can be cut in a sliding sleeve locked in place by a shearing mechanism. The translation of this sleeve may open the conduits **148**.

[0044] FIGS. 4A-4I illustrate a sequence of operations including installation of the liner string of FIG. 1, a cementing operation, and installation of a completion string inside the liner string after the cementing operation.

[0045] In FIG. 4A, the liner string of FIG. 1 (including the liner, liner hanger, liner devices, control line, and connector) along with the tool string of FIG. 3 are run together into the wellbore **10**. As shown, the running tool **150** is connected by the dogs **152** to the nipple **156** connected to the liner hanger **16**. Once the liner hanger **16** has been set against the inner wall of the casing **12**, a ball **200** can be dropped to sealingly engage a seat **160** in the running tool **150**, as shown in FIG. 4B. An applied elevated pressure inside the pipe **170** attached to the running tool **150** creates a differential pressure across the locking sleeve **158**. If a sufficient differential pressure is created, the force applied on the locking sleeve **158** causes breakage of the shearing mechanism and upward movement of the locking sleeve **158**. A groove **157** of the locking sleeve **158** allows the locking dogs **152** to drop away from the recess **154** of the nipple **156** when the locking sleeve **158** has moved upwardly by a sufficient distance. This causes the running tool **150** to disengage from the nipple **156**, as shown in FIG. 4B.

[0046] Once the dogs **152** are disengaged, a further increase in the differential pressure across the ball **200** sitting in the seat **160** may shear the shearing mechanism attaching

the ball seat **160** to the running tool **150**. The ball seat **160** then translates downwardly to impact the shoulder **163** of the pulling tool housing **131**. At this point, the force applied against the ball **200** can push the upper ring **161** of the ball seat **160** outwardly so that the ball **200** can pass through the ball seat. The ball **200** drops into the pulling tool **130** to sit in the seat **146** of the pulling tool, as shown in FIG. 4C. The running string including the pipe **170**, the running tool **150**, and the pulling tool **130** is then lowered to engage the pulling tool **130** inside the cement protector **100**. If the liner devices are positioned outside the casing **12** instead of the liner **14**, then the running tool **150** may be omitted.

[0047] As shown in FIG. 4D, as the pulling tool **130** is lowered into the cement protector sleeve **110**, the fingers **136** are pushed upwardly and radially collapsed by abutment with the upper end of the cement protector sleeve **110**. As the pulling tool **130** is pushed further into the cement protector sleeve **110**, the seals **144** carried by the pulling tool **130** are sealingly engaged in the seal bore **122** of the cement protector sleeve **110**, as shown in FIG. 4E. Also, the protruding portions **142** of the fingers **136** are engaged in the recess **120** of the locking sleeve **116**.

[0048] When running in, the running string is releasably attached to an upper end of the liner string to avoid two generally concentric tubular structures (the liner **14** and the pipe **170**) traversing a large distance together, which may greatly increase the weight of the run-in assembly. Instead, according to some embodiments, the running string is moved downwardly from the upper end of the liner string to the lower end to engage the cement protector **100** after the liner hanger **16** is set.

[0049] More generally, the running string may be replaced with any type of run-in tool, and the cement protector **100** may be replaced with any type of run-in receiver. The general concept is that the run-in tool lowers a liner or some other downhole structure into the wellbore, followed by releasing the run-in tool. Next, the run-in tool is lowered into the wellbore until it is received by the run-in receiver or coupled to the liner **14**.

[0050] When the pulling tool **130** is engaged in the cement protector sleeve **110**, fluid communication is provided between the inside of the running string **170** and the inside of the cement protector sleeve **110** through the angled conduits **148**. As further shown in FIG. 4E, the cementing operation is started, in which a cement slurry **202** is pumped through the angled conduits **148** of the pulling tool **130** into the inner bore of the cement protector sleeve **110**. The cement slurry is pumped by downward movement of a cement plug **203** (not shown in FIG. 4E but shown in FIG. 4F). As elevated pressure is applied above the plug **203** to supply the downward movement. The cement slurry flows through the ports **132** of the cement protector **100** and conduits **134** of the connector sub **102** into the liner shoe **22** through the check valve **106**. The cement slurry continues through liner shoe openings **107** into the annulus region **105** between the outer wall of the liner **14** and the inner wall of the wellbore **10**. As shown in FIG. 4F, the cement slurry continues up an annulus region **174** between the outside of the liner **14** and the inside of the casing **12**. The cementing operation may be stopped once the plug **203** contacts the ball **200**. The cement between the outside of the liner **14** and the

inside of the casing **12** provides a relatively good seal to prevent leakage of wellbore fluids up the annulus region between the liner and casing.

[0051] After the cementing operation has been completed, the running string may be pulled out of the wellbore **10**. As shown in **FIG. 4G**, an upward shifting of the running string causes the protruding portions **142** of the fingers **136** to pull upwardly on the locking sleeve **116** of the cement protector. Upward movement of the locking sleeve **116** enables release of the locking dogs **114** so that the cement protector **100** is released from the liner **14**. At this point, the running string and cement protector **100** may be pulled out of the wellbore, as shown in **FIG. 4H**. The cement protector **100** may be easily retrieved before the cement has dried. As the cement protector **100** is retrieved, the cement remains inside the cement protector sleeve **110**, with the inner wall of the liner **14** remaining substantially clear of cement. It is noted that some leakage of cement may flow into the inner bore of the liner **14**. However, the amount of such leakage may be small enough so that a subsequent cleaning operation is not needed.

[0052] As further illustrated in **FIG. 4H**, an orienting profile **210** is provided in the inner wall of the liner **14** to allow alignment of connector(s) of the completion string with the connector(s) of the liner **14**. Next, as shown in **FIG. 4I**, the completion string, including a flow control device **212** (in one example embodiment) and a connector sub **214**, may be run into the wellbore. The connector sub **214** is oriented by the orienting profile **210** to align the connector(s) **32** to the liner connector(s) **24**.

[0053] In accordance with some embodiments, downhole components have been described to enable connection between devices positioned outside of a liner and components inside the liner. This may be accomplished by running one or more control lines from the liner devices to one or more connectors that provide connection points inside the liner below the well surface. The one or more connectors may include electrical connectors (e.g., direct contact connectors), inductive connectors (e.g., inductive couplers), optical connectors (e.g., fiber optic connectors), hydraulic connectors, or other connectors. The one or more control lines may be electrical lines, fiber optic lines, hydraulic lines, or other control lines.

[0054] In accordance with further embodiments, a cement protector may be used during cementing operations to protect both the inside of the liner as well as the one or more connectors attached to the liner. The cement protector includes a sleeve that isolates cement from the inside of the liner during a cementing operation. The cement protector is engageable to a pulling tool that is attached to a running tool. The running tool in turn is connected to a pipe through which a cement slurry can be pumped. The cement slurry pumped through the inner bore of the pipe enters the sleeve of the cement protector. One or more ports are provided in the cement protector to enable communication of the cement slurry to an annulus region between the outer wall of the liner and the inner wall of the wellbore.

[0055] While the invention has been disclosed with respect to a limited number of embodiments, those skilled in the art will appreciate numerous modifications and variations therefrom. It is intended that the appended claims cover all such modifications and variations as fall within the

true spirit and scope of the invention. For example, instead of using locking dog assemblies in the described attachment mechanisms, other releasable attachment mechanisms may be used, such as those including collets. Also, instead of using a ball dropped from the well surface to create isolation for generating an elevated pressure, a valve (e.g., a ball valve) may be used instead.

What is claimed is:

1. An apparatus for use in a well having a well surface and a wellbore lined with a liner, comprising:

a device positioned outside the liner;

a control line connected to the device and extending outside the liner; and

a connector connected to the control line and providing a connecting point accessible from inside the liner below the well surface.

2. The apparatus of claim 1, wherein the liner has a lower end, the connector positioned in the proximity of the liner lower end.

3. The apparatus of claim 2, wherein the liner includes an inner bore and the connector is positioned to mate with a component lowered through the liner inner bore.

4. The apparatus of claim 3, wherein the component includes a corresponding connector.

5. The apparatus of claim 3, further comprising:

another connector positioned in the proximity of the liner lower end; and

an orienting profile to orient the component with respect to the connectors.

6. The apparatus of claim 5, wherein the component includes plural corresponding connectors.

7. The apparatus of claim 2, further comprising:

a liner shoe attached to the liner lower end; and

a connector sub including the connector, the connector sub positioned proximal the liner shoe.

8. The apparatus of claim 1, wherein the device includes an electrical device.

9. The apparatus of claim 8, wherein the device includes a resistivity electrode.

10. The apparatus of claim 1, wherein the device includes a hydraulic device.

11. The apparatus of claim 1, further comprising at least another device positioned outside the liner.

12. The apparatus of claim 1, wherein the connector is selected from the group consisting of an electrical connector, an inductive coupler, an optical connector, and a hydraulic connector.

13. The apparatus of claim 1, further comprising a cement protector removeably positioned in the liner and covering the connector.

14. A well communication system for a well having a liner, the system comprising:

a device positioned outside the liner;

a control line extending from the device to a lower end of the liner; and

a connector connected to the control line and accessible from within the liner.

**15.** The system of claim 14, further comprising a control line extending from the connector through the liner to the well surface.

**16.** The system of claim 14, further comprising a cement protector removeably positioned in the liner and covering the connector.

**17.** A downhole communication apparatus, comprising:

a liner having a lower end; and

a communication connector assembly attached to the liner.

**18.** The apparatus of claim 17, further comprising the communication connector positioned at the lower end of the liner.

**19.** The apparatus of claim 18, wherein the communication connector assembly includes a connector and a sub attached to the liner lower end.

**20.** A method for communicating with a device positioned outside a liner, the method comprising:

routing one or more control lines from the device to an internal passageway of the liner and to the surface.

**21.** The method of claim 20, further comprising providing one or more connectors in the one or more control lines between the outside of the liner and the internal passageway of the liner.

**22.** The method of claim 21, further comprising placing the one or more connectors proximal a lower end of the liner.

**23.** The method of claim 22, further comprising running a tool into the internal passageway of the liner, the tool including one or more connectors adapted to mate with the one or more liner connector.

**24.** An apparatus for use in a wellbore having a liner with an inner bore, comprising:

a cement protector to prevent or reduce communication of cement into the liner inner bore during a cementing operation, the cement protector including a sleeve and one or more ports; and

a running string attached to the cement protector, the running string adapted to communicate cement through the one or more cement protector ports to a region outside the liner.

**25.** The apparatus of claim 24, wherein the cement protector further includes a locking device to releasably engage the cement protector to the liner.

**26.** The apparatus of claim 25, wherein the cement protector further includes a profile, wherein the running string is adapted to engage the profile to release the locking device to enable retrieval of the cement protector.

**27.** The apparatus of claim 26, further comprising a connector sub including one or more connectors, the cement protector defining a chamber in communication with the one or more connectors to isolate cement from the one or more connectors.

**28.** The apparatus of claim 27, wherein the chamber is filled with a fluid to protect the one or more connectors.

**29.** The apparatus of claim 27, wherein the one or more connectors each includes a connector selected from the group consisting of an electrical connector, an inductive coupler, an optical connector, and a hydraulic connector.

**30.** The apparatus of claim 24, wherein the running string includes a running tool releasably engaged to the liner.

**31.** The apparatus of claim 30, wherein the liner is part of a liner string that further includes a liner hanger and a nipple, the running tool being releasably attached to the nipple.

**32.** The apparatus of claim 30, wherein the running string is moveable longitudinally upon release to engage the cement protector.

**33.** The apparatus of claim 30, wherein the running tool includes a ball seat to receive a ball, the running tool including an inner bore and a locking device to releasably engage the liner, the locking device adapted to be released by an increase in pressure in the running tool inner bore after the ball is sealingly engaged in the ball seat.

**34.** The apparatus of claim 33, wherein the ball seat is releasably attached to a housing of the running tool, wherein a further increase in pressure causes the ball seat to be released and to enable the ball to drop through the ball seat.

**35.** The apparatus of claim 34, wherein the running string further includes a second ball seat below the first ball seat, the second ball seat adapted to receive the ball after the ball drops through the first ball seat.

**36.** The apparatus of claim 35, wherein the running string further includes one or more ports to enable fluid communication between the inside and outside of the running string after the ball has dropped into the second ball seat.

**37.** A method of completing a well having an inner wall, comprising:

running a liner string including a liner having an inner bore into the wellbore;

running a cement protector into the liner; and

introducing a cement slurry into the wellbore, the cement slurry communicated through the cement protector to an annulus between the liner and the wellbore inner wall,

the cement protector isolating the cement slurry from the liner inner bore.

**38.** The method of claim 37, wherein running the liner string and running the cement protector are performed in the same run.

**39.** The method of claim 37, wherein running the liner string includes running the liner string releasably attached to a running string.

**40.** The method of claim 39, further comprising releasing the running string and moving the running string to engage the cement protector.

**41.** The method of claim 40, wherein introducing the cement slurry includes introducing the cement slurry through the running string.

**42.** The method of claim 41, further comprising retrieving the running string and cement protector after the cementing operation.

**43.** A method for use in a wellbore, comprising:

running a liner string into the wellbore, the liner string including a liner having an inner bore, a device positioned outside the liner, a control line connected to the device and extending outside the liner, and a connector connected to the control line and accessible from the liner inner bore; and

running a second string into the wellbore, the second string having a connector; and

mating the liner string connector with the second string connector.

**44.** The method of claim 43, wherein running the second string includes running a production string including a production tubing.

**45.** The method of claim 43, wherein the liner string includes plural connectors and the second string includes plural connectors, the method further comprising orienting the second string connectors to align with corresponding liner string connectors.

**46.** A liner running and cementing apparatus, comprising:

a run-in tool releasably connectable to an upper portion of the liner;

a run-in tool receiver positioned proximal a lower end of the liner; and

the run-in tool receiver adapted to receive the run-in tool.

**47.** The apparatus of claim 46, wherein the run-in tool receiver comprises a lower protector sleeve releasably attached to a lower end of the liner.

**48.** The apparatus of claim 46, further comprising a communication conduit attached to the run-in tool providing fluid communication from a well surface to the run-in tool.

**49.** A method for use in a wellbore, comprising:

running a liner into the wellbore on a run-in tool;

moving the run-in tool to a bottom end of the liner;

connecting the run-in tool to a structure proximal the liner bottom end; and

flowing cement through the run-in tool and then through the bottom end of the liner.

\* \* \* \* \*