



US 20010015058A1

(19) **United States**

(12) **Patent Application Publication**
SNYDER

(10) **Pub. No.: US 2001/0015058 A1**

(43) **Pub. Date: Aug. 23, 2001**

(54) **FORCED PURGE WAVE ROTOR**

Related U.S. Application Data

(76) Inventor: **PHILIP H. SNYDER, PLAINFIELD, IN (US)**

(63) Continuation of application No. 08/857,529, filed on May 16, 1997, now Pat. No. 5,916,125.

Publication Classification

Correspondence Address:
**WOODARD EMHARDT NAUGHTON
MORIATY & MCNETT
BANK ONE CENTER TOWER
111 MONUMENT CIRCLE SUITE 3700
INDIANAPOLIS, IN 462045137**

(51) **Int. Cl.⁷ F02C 1/00**
(52) **U.S. Cl. 60/39.02; 60/39.45**

(57) **ABSTRACT**

A wave rotor apparatus and method of using the transient gas dynamic processes within the wave rotor to accomplish an engine topping cycle. In one form of the present invention the wave rotor is a five port device. Working fluid from the highest pressure outlet port is routed to a port adjacent to and preceding an inlet port admitting air from the compressor. In a preferred form of the present invention there are two port sequences disposed along the circumference of the wave rotor apparatus.

(*) Notice: This is a publication of a continued prosecution application (CPA) filed under 37 CFR 1.53(d).

(21) Appl. No.: **09/315,003**

(22) Filed: **May 19, 1999**

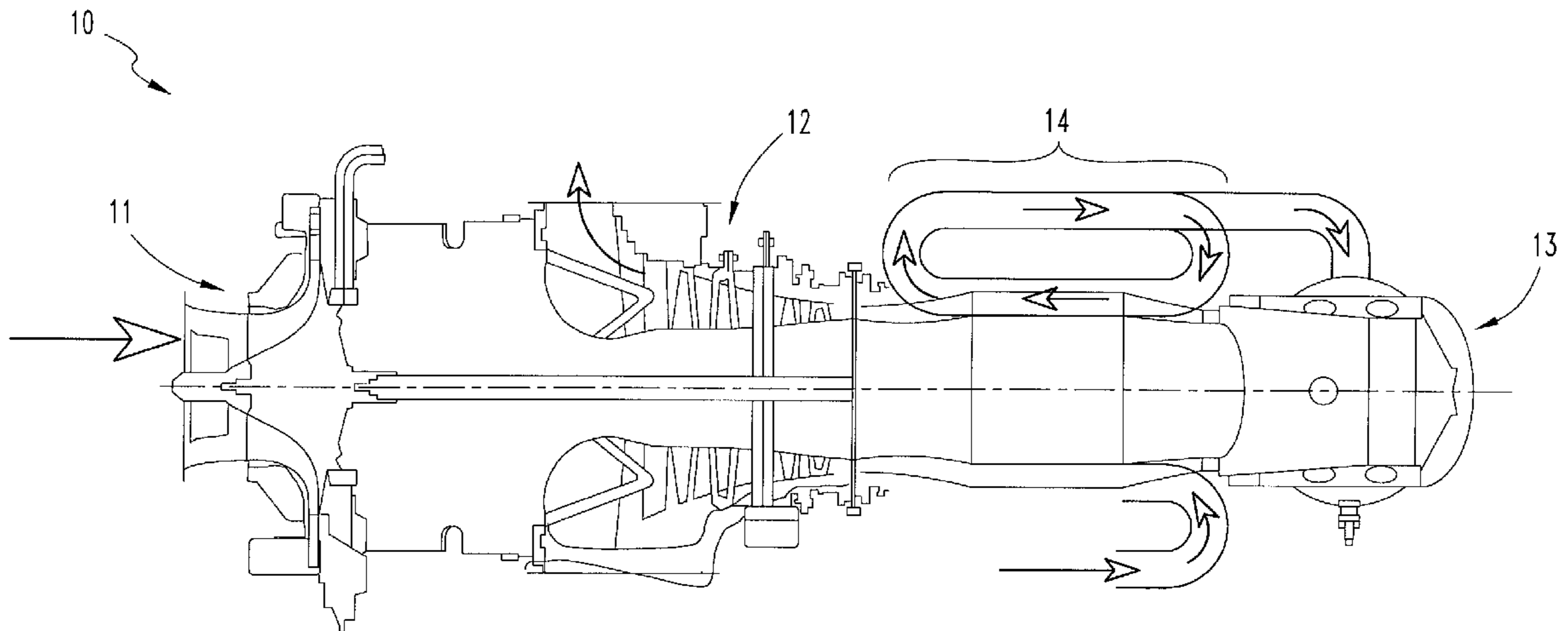

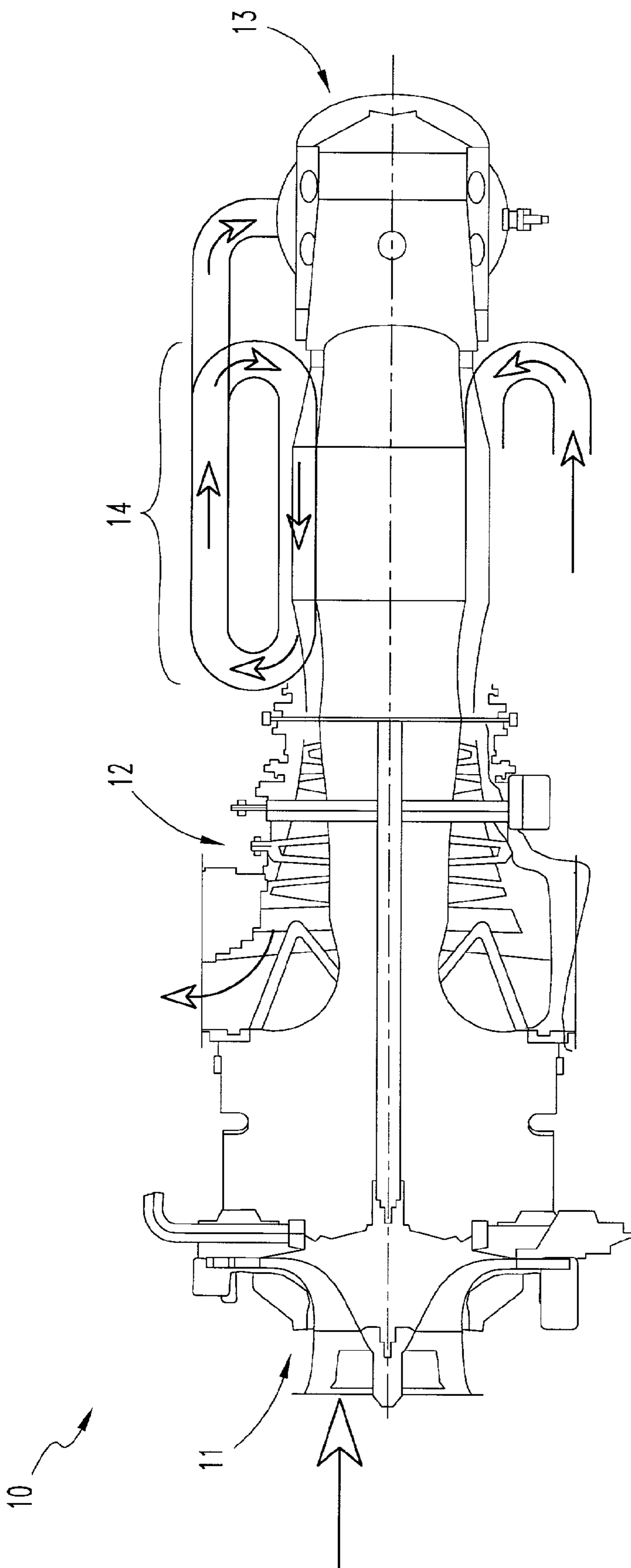

Fig. 1

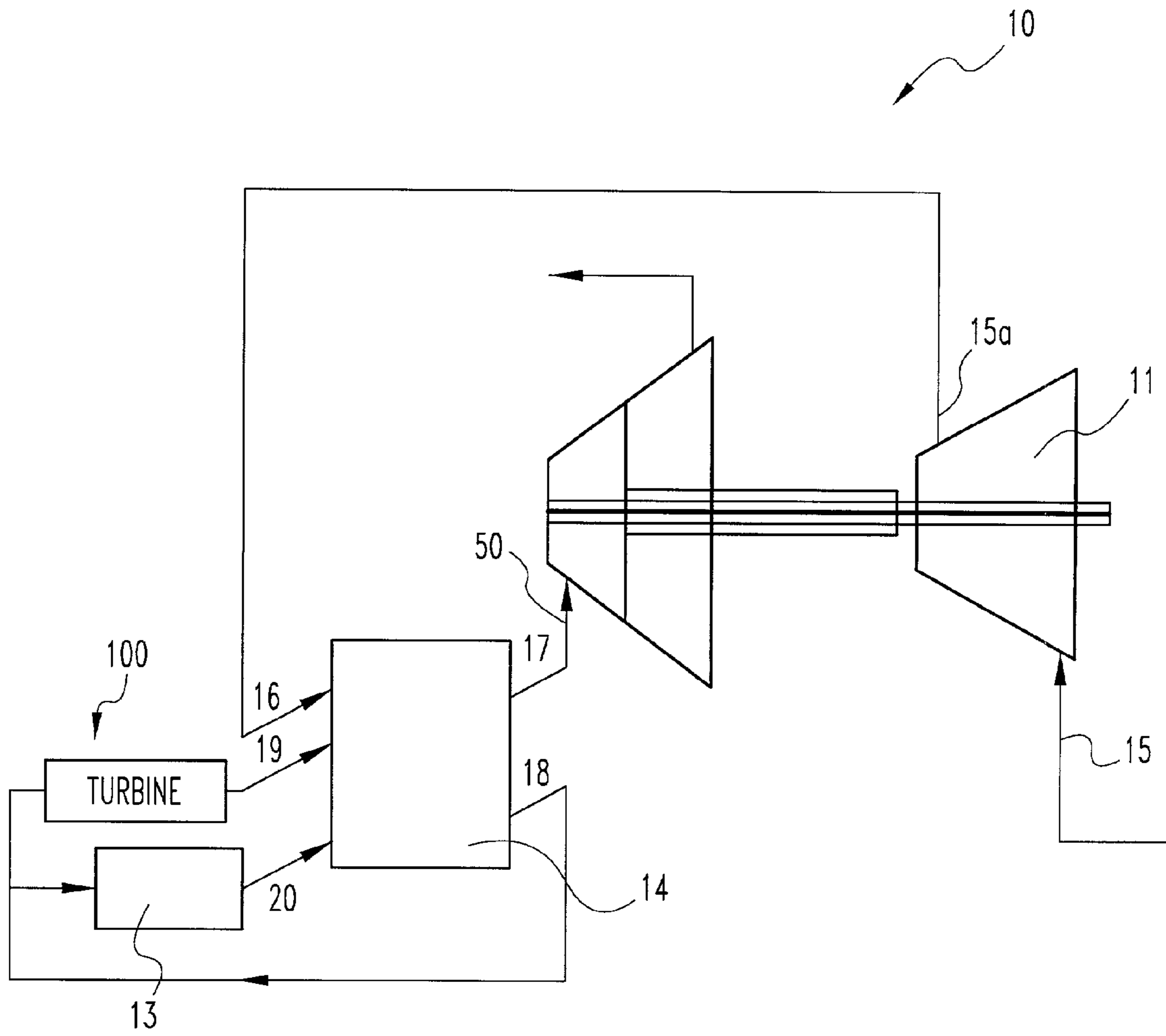

Fig. 2

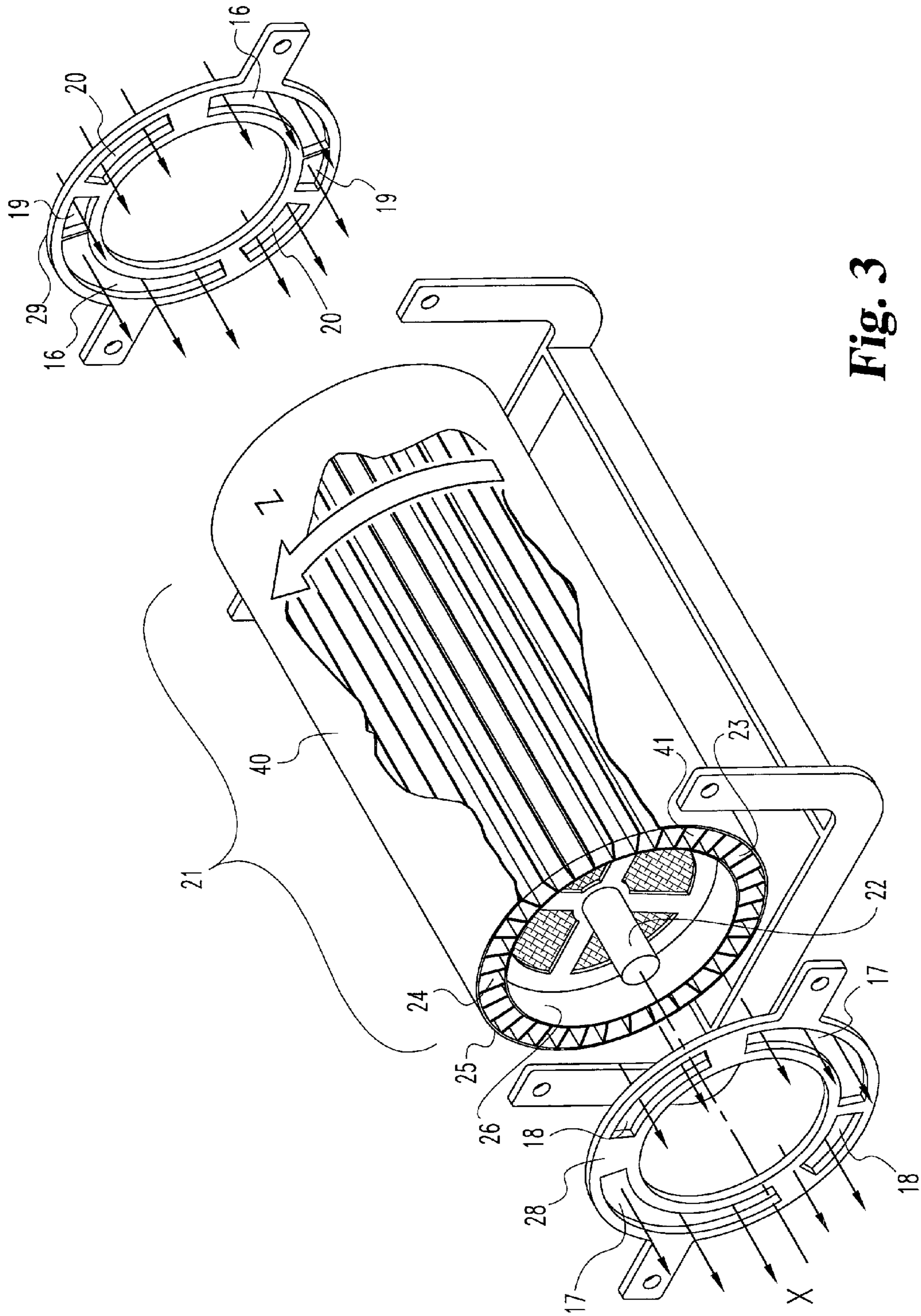
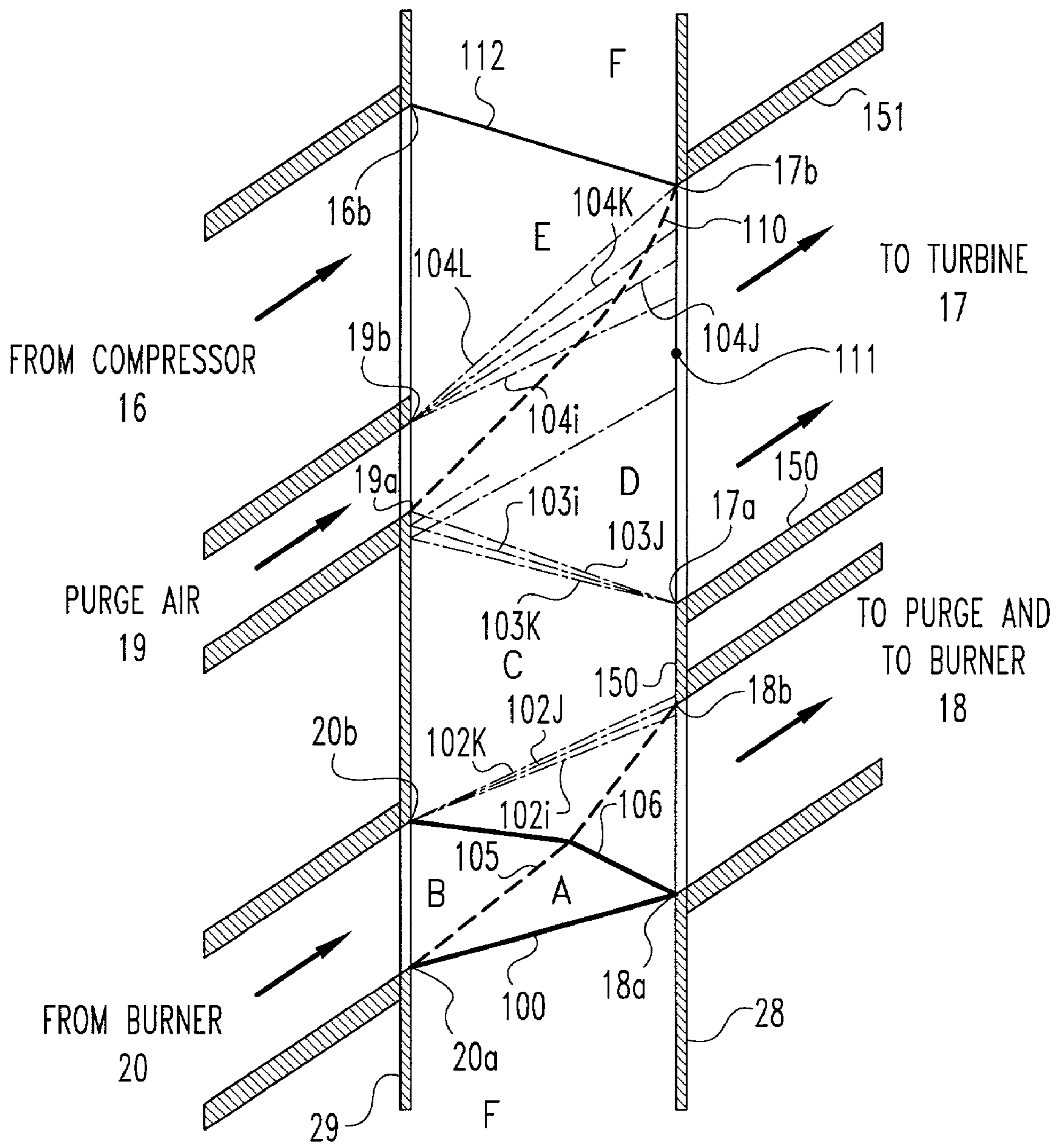

Fig. 3



- SHOCK
- HOT TO COLD GAS INTERFACE
- · - · - COLD TO COLD GAS INTERFACE
- EXPANSION

Fig. 4

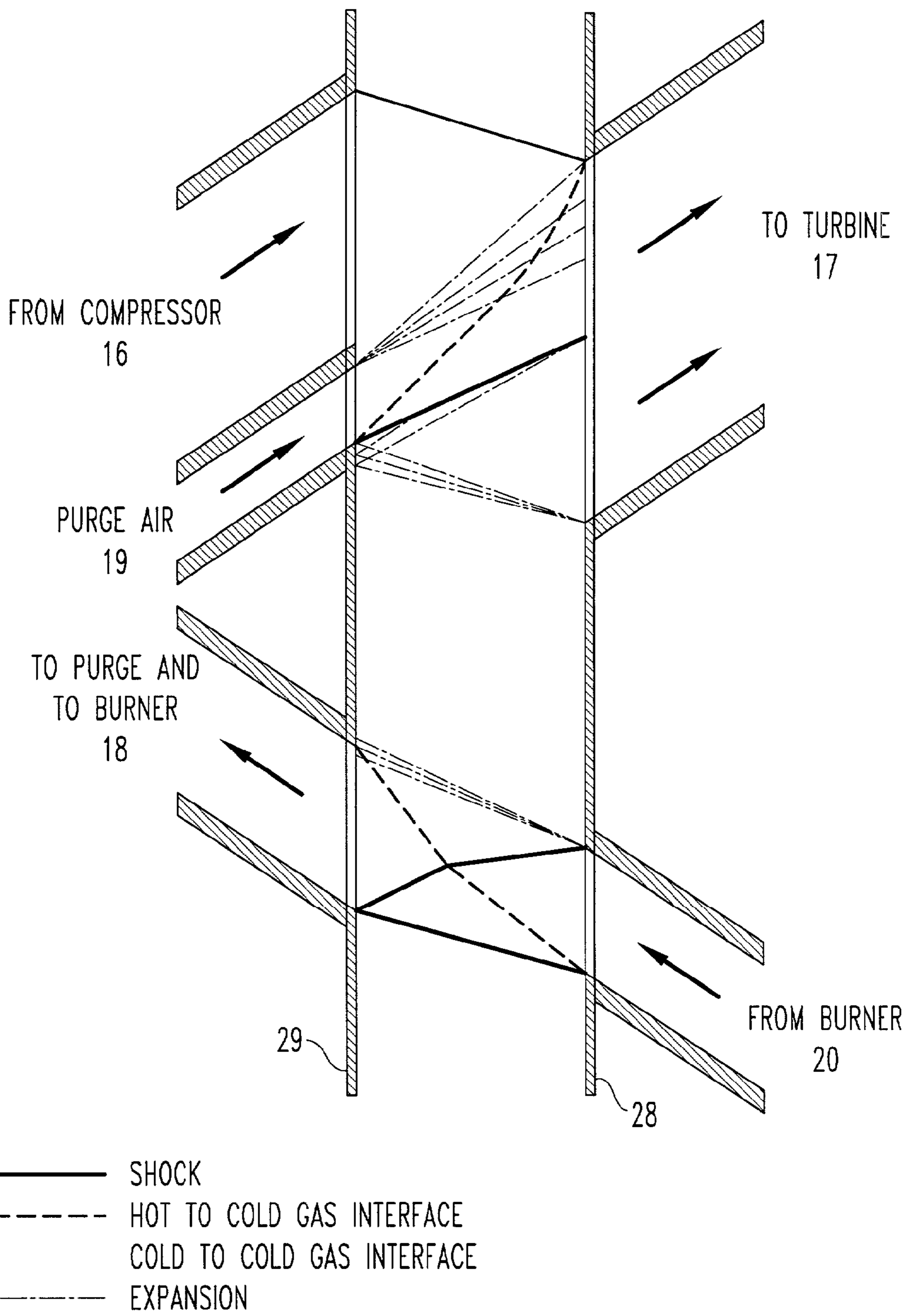

Fig. 5

FORCED PURGE WAVE ROTOR

BACKGROUND OF THE INVENTION

[0001] The present invention relates generally to a wave rotor apparatus and a method of using the transient gas dynamic processes within the wave rotor to accomplish an engine topping cycle. More particularly, in one embodiment of the present invention a portion of the gases in the highest pressure portion of the wave rotor based topping cycle are routed to a port adjacent to and preceding an inlet port admitting air from the compressor. Although the present invention was developed for use with a gas turbine engine, certain applications may be outside of this field.

[0002] A wave rotor is generally thought of as a generic term and describes a class of machines utilizing transient internal fluid flow to efficiently accomplish a desired flow process. Since the 1940's wave rotors have been studied by engineers and designers, and identified as particularly adapted for use in a gas turbine engine. Performance levels of gas turbine engines are enhanced by the integration of a wave rotor based topping cycle thereon.

[0003] Presently, a considerable amount of research is directed to improving the specific power and decreasing the specific fuel consumption of gas turbine engines. One approach to obtaining these goals is to raise the compressor pressure ratio (compressor exit pressure/compressor inlet pressure), and/or increase the combustor temperature. However, several constraints have inhibited the realization of an aircraft gas turbine engine having a significantly raised compressor pressure ratios and/or combustor temperatures.

[0004] Increasing the pressure ratio causes an increased gas density that often necessitates the use of smaller passages and blading. Associated with smaller passages and blading is an increased surface area that can cause decreased component efficiency related to frictional losses. Also associated with smaller passages and blading are losses related to increased blade tip leakages due to proportionately larger tip clearances. Therefore, all or a portion of the theoretical improvement and cycle efficiency attributed to the increase in the pressure ratio may be negated by the decrease in component efficiency. Current material limitations and cooling techniques for aircraft gas turbine engines have been inadequate to accommodate significantly increased operating temperatures, thus, inhibiting any significant working fluid temperature increase in the gas turbine.

[0005] Suitably designed wave rotors can function like key portions of conventional gas turbine engines to extract useful work by compressing and expanding the working fluid. However, unlike the conventional gas turbine engine that utilizes rotating airfoils, the transfer and extraction of energy in a wave rotor involves unsteady transient waves and flow processes. The wave rotor used in a cycle topping role allows an increase in the engine pressure ratio without suffering high losses. Simultaneously, the combustor exit temperature can be increased while using present material technology because the wave rotor has a self cooling feature occurring within its passageways. The self cooling feature utilizes intermittently exposing individual passageway walls of the wave rotor to alternating elevated and reduced temperature gas flows, so that the thermal capacitance of the passageway walls can hold the average material temperature to an acceptable level.

[0006] Although prior wave rotors and methods of using transient gas flows are steps in the right direction, the need for additional improvements still remains. The present invention satisfies this need in a novel and unobvious way.

SUMMARY OF THE INVENTION

[0007] One embodiment of the present invention contemplates a combination of a gas turbine engine having a compressor and a turbine and a wave rotor comprising: a rotor having a plurality of passageways therethrough for gas flow; a plurality of sequential exit ports disposed in fluid communication with the rotor for receiving gas exiting the plurality of passageways, one of the plurality of exit ports being a first exit port having a pressure greater than the rest of the plurality of exit ports; a plurality of sequential inlet ports disposed in fluid communication with the rotor for allowing gas to flow into the plurality of passageways, one of the plurality of inlet ports being a compressor inlet port for receiving gas from the compressor; and a passageway coupled between the first exit port and a second of the plurality of inlet ports positioned adjacent to and prior the compressor inlet port for delivering gas to the rotor.

[0008] Another embodiment of the present invention contemplates a method utilizing a wave rotor to top a gas turbine engine's cycle. The method comprising: providing the wave rotor having a rotatable rotor with a plurality of fluid passageways for the passage of a working fluid therethrough; rotating the rotor so as to sequentially pass the plurality of fluid passageways by a plurality of wave rotor inlet ports and a plurality of wave rotor outlet ports; discharging a portion of the working fluid within at least one of the plurality of fluid passageways through one of the plurality of outlet ports, wherein the one outlet port having the highest pressure of any of the plurality of outlet ports; reducing the pressure of the portion of the working fluid after the discharging; and introducing the portion of the working fluid into one of the plurality of inlet ports after the reducing.

[0009] One object of one form of the present invention is to provide an improved wave rotor for a gas turbine engine.

[0010] Related objects and advantages of the present invention will be apparent from the following description.

BRIEF DESCRIPTION OF THE DRAWINGS

[0011] FIG. 1 is an illustrative side elevational view of a gas turbine engine having a forced purge wave rotor of the present invention coupled thereto.

[0012] FIG. 2 is a schematic representation of the FIG. 1 gas turbine engine and forced purge wave rotor.

[0013] FIG. 3 is a perspective view of the forced purge wave rotor comprising a portion of FIG. 1.

[0014] FIG. 4 is a space-time (wave) diagram for a through flow type forced purge wave rotor topping cycle.

[0015] FIG. 5 is a space-time (wave) diagram for a reverse flow type purge wave rotor topping cycle.

DESCRIPTION OF THE PREFERRED EMBODIMENT

[0016] For the purposes of promoting an understanding of the principles of the invention, reference will now be made

to the embodiment illustrated in the drawings and specific language will be used to describe the same. It will nevertheless be understood that no limitation of the scope of the invention is thereby intended, such alterations and further modifications in the illustrated device, and such further applications of the principles of the invention as illustrated therein being contemplated as would normally occur to one skilled in the art to which the invention relates.

[0017] With reference to **FIG. 1**, there is illustrated a gas turbine engine **10** which includes a compressor **11**, a turbine **12**, a combustor/burner **13**, and a forced purge wave rotor **14**. The three components have been integrated together to produce an aircraft flight propulsion engine. It is important to realize that there are a multitude of ways in which the components can be linked together. Additional compressors and turbines can be added with inner coolers connected between the compressor and reheat combustion chambers to be added between the turbines. Further, the gas turbine engine is equally suited to be used for industrial applications. Historically there has been wide spread application of industrial gas turbine engines, such as pumping sets for gas or oil transmission lines, electricity generation and naval propulsion.

[0018] With reference to **FIG. 2**, there is a schematic representation of the gas turbine engine **10** with wave rotor **14** coupled thereto. The wave rotor **14** utilizes cyclic transient gas dynamic processes to top the engine's basic cycle (conventional Brayton gas turbine cycle) through the use of shock waves, expansion waves and hot to cold working fluid interfaces. To top a gas turbine engine includes providing additional compression following the last stage of conventional compression prior to the combustion process, and additional expansion prior to the first stage of conventional expansion.

[0019] Compressor **11** has a compressor inlet port **15** for receiving a working fluid flow therein. The compressor **11** operates in a traditional fashion to increase the pressure of the working fluid between the compressor inlet port **15** and a compressor outlet port **15a**. It is understood that in the preferred embodiment the working fluid is a gas, and it is more preferred that the working fluid is air. The increase in working fluid pressure is represented by a pressure ratio (pressure at compressor outlet port **15a**/pressure at compressor inlet port **15**) and the pressurized working fluid is delivered via a duct to a wave rotor inlet port **16**. A second wave rotor inlet port **20** provides a pathway for the introduction of working fluid from the combustor/burner **13** to the wave rotor **14**. A third wave rotor inlet port **19** is referred to hereinafter as a purge inlet port, and is located adjacent to and sequentially prior to the wave rotor inlet port **16**. It is understood that the wave rotor inlet ports **20**, **19** and **16** form an inlet port sequence for the wave rotor topping cycle, and that multiple cycles can be integrated into a wave rotor apparatus. In the preferred embodiment there are two inlet port sequences disposed along the circumference of the wave rotor apparatus.

[0020] The wave rotor **14** has a pair of wave rotor exit ports **17** and **18** that facilitate the discharge of working fluid from the wave rotor. The first wave rotor exit port **17** is positioned generally opposite the wave rotor purge inlet port **19** and allows working fluid to exit the wave rotor through a duct and flow to a turbine inlet port **50**. The second wave

rotor outlet port **18** allows working fluid to exit the wave rotor and flow via a duct to the combustor/burner **13** and the wave rotor purge inlet port **19**. Working fluid from exit port **18** is divided between the combustor/burner **13** and the wave rotor purge inlet port **19**. The mass flow rate of working fluid from the wave rotor into the combustor/burner **13**, in comparison to a device absent port **19**, is thereby reduced. It is understood that the wave rotor outlet ports **17** and **18** form an outlet port sequence for the wave rotor topping cycle, and that multiple cycles can be integrated in a wave rotor apparatus. In the preferred embodiment there are two outlet port sequences disposed along the circumference of the wave rotor apparatus. The inlet port sequence and outlet port sequence are combined with a rotatable rotor to form the topping cycle. Further, the routing of the working fluid from the outlet port **18** to the combustor/burner **13** and the purge inlet port **19** utilizes the energy of the working fluid to increase fluid pressure and velocity, and more thoroughly purge and deliver the hot working fluid out of the wave rotor and into the turbine.

[0021] In one form of the present invention the portion of the working fluid exiting the outlet port **18** that is routed to the purge inlet port **19** must be brought to a pressure and may be brought to a temperature below the conditions existing at the outlet port **18**. One method of reducing the pressure of this working fluid exiting outlet port **18** is to pass the working fluid through an orifice or duct so as to create frictional losses. Temperature reduction of the working fluid can be accomplished via conventional intercooling. Further, one form of the present invention utilizes a gas driven turbine device **100** to provide work extraction to reduce the pressure and temperature of the working fluid flowing to purge inlet port **19**.

[0022] With reference to **FIG. 3**, there is illustrated one embodiment of the wave rotor apparatus **21**. Wave rotor apparatus **21** preferably comprises a cylindrical rotor **40** that is rotatable about a centerline **X** so as to pass a plurality of fluid passageways **23** by the plurality of inlet ports **16**, **19**, **20** and outlet ports **17**, **18** that are formed in end plates **28** and **29**. The end plates are coupled to the stationary ducted passageway between the wave rotor **21** and other engine components as illustrated in **FIG. 2**. The plurality of fluid passageways **23** are positioned about the circumference of the wave rotor apparatus **21**. It is understood herein that in one embodiment the rotation of the rotor **40** is accomplished by conventional rotational devices within the contemplation of one of ordinary skill in the art. The gas driven turbine **100** can also be used as the rotational means to cause the rotation of the wave rotor **40**. Further, in another embodiment the rotor is a self turning, free-wheeling design; wherein free-wheeling indicates no independent drive means. The types of rotational means are not intended to be limited herein and include other devices for rotating the rotor **40** within the contemplation of someone of ordinary skill in the art. One form of the present invention utilizes rotational speeds in a range of about 1,000 to 50,000 revolutions per minute, and more preferably is about 17,000 revolutions per minute.

[0023] Transient gas dynamic processes within the rotating passageways **23** are set up by the abrupt exposure and closing of the ends of the plurality of passageways **23** to the environmental conditions existing at the respective port inlet and exit locations. The transient gas dynamic processes are designed to be compatible with steady flow devices utilized

with the wave rotor **14** because the transient processes are cyclic within each of the plurality of passageway **23**, and the use of a plurality of adjacent passageways **23** allows identical transient processes to occur in a time staggered phase relationship within adjacent passages.

[0024] The wave rotor **40** is fixedly coupled to a shaft **22** that is rotatable on a pair of bearings (not illustrated). In one form of the present invention the wave rotor **40** rotates about the centerline X in the direction of arrow Z. The direction Z may be concurrent with or counter to the rotation direction of the gas turbine engine rotors. The plurality of circumferentially spaced passageways **23** extend along the length of the wave rotor apparatus **21** parallel to the centerline X and are formed between an outer wall member **25** and an inner wall member **26**. The plurality of passageways **23** define a peripheral annulus **24** wherein adjacent passageways share a common wall member **41** that connects between the outer wall member **25** and the inner wall member **26** so as to separate the fluid flow within each of the passageways.

[0025] A pair of wave rotor end plates **28** and **29** are fixedly positioned very closely adjacent the rotor **40** so as to control the passage of working fluid into and out of the plurality of passageways **23** as the rotor **40** rotates about centerline X. The wave rotor end plates **28** and **29** are located in a sealing arrangement with the rotor **40** so as to prevent the leakage of fluid from the plurality of passageways **23**. Additional auxiliary seals (not illustrated) are included in one form of the present invention to increase the sealing efficiently. Seal types, such as but not limited to, labyrinth glands or sliding seals are contemplated herein, however the application of seals to a wave rotor are believed known to a person of ordinary skill in the art.

[0026] Wave rotor end plate **29** is an inlet endplate and includes a plurality of circumferentially spaced wave rotor inlet ports. In the preferred embodiment a pair of inlet port sequences **20**, **19** and **16** are formed therethrough. The opposite other wave rotor end plate **28** being an outlet endplate that has a plurality of wave rotor outlet ports **17** and **18** formed therethrough. In the preferred embodiment a pair of outlet port sequences **17** and **18** are formed therethrough. In one form of the present invention the working fluid transfer duct from the wave rotor exit port **18** to the purge inlet port **19** is integral with the wave rotor apparatus **21** and passes through the center of rotor **40**, and more particularly through the center of shaft **22**. In another form of the present invention the transfer duct is external to the wave rotor **40**. The respective location of size of each of the inlet and outlet ports is determined by gas characteristics that are discussed with reference to FIGS. 4 and 5.

[0027] With reference to FIG. 4, there is illustrated a wave diagram for a through flow type purge wave rotor topping cycle demonstrating the defining features of the forced purge wave rotor invention. From the description above, it can be seen that upon rotation of rotor **40**, each of the plurality of passageways **23** are sequentially brought into registration with the inlet and outlet ports and the path of a typical charge of working fluid is along the respective passageway **23**. The through flow type purge wave rotor topping cycle for the purpose of description may be started at any point.

[0028] Working fluid of relatively high temperature and pressure is introduced from the burner/combustor **13** to the passageway **23** through inlet port **20**. Preferably, the work-

ing fluid is provided from burner/combustor **13** which functions to heat the working fluid provided thereto and is of a conventional design. Further, the wave speeds within the wave rotor **14** are sonic or higher, and the working fluid speeds are subsonic to near sonic.

[0029] Working fluid of relatively low temperature and pressure in region F is compressed by shockwaves **100** and **106** and forced out of the wave rotor through exit port **18**. The working fluid in region A is allowed to exit through outlet port **18** while the passageway **23** is brought into registration therewith. The working fluid exiting the outlet port **18** has the highest pressure of any of the outlet ports. Upon exiting outlet port **18** the working fluid from region A is divided between the combustor/burner **13** and the purge inlet port **19**.

[0030] A dashed line **105** represents a hot to cold working fluid interface between the hot working fluid region B and the lower temperature working fluid in region A. The rotation of rotor **40** brings the passageway **23** into registration with inlet port **20** and allows the introduction of the high pressure high temperature working fluid from the burner/combustor **13**. Pressure and temperature conditions in passageway **23** and outlet port **18** allow the working fluid in region A to exit upon the registration of passageway **23** with outlet **18**. A shock wave **100** emanates from the leading edge **20a** of inlet port **20** and traverses through the passageway **23** to the opposite end plate **28** to define the leading edge **18a** of the outlet port **18**.

[0031] A second shock wave **106** is setup at the leading edge **18a** of outlet port **18** and traverses back down the passageway **23**, thereby raising the pressure of the working fluid in both the hot working fluid region B and the cooler working fluid region A. The second shock wave **106** continues through the passageway **23** to endplate **29** where it defines the trailing edge **20b** of inlet port **20**. Continued rotation of rotor **40** causes inlet port **20** to be closed and a plurality of expansion waves **102i**, **102j** and **102k** (only three shown for illustrative purposes) to be created at the trailing edge **20b** of the inlet port **20** and the plurality of expansion waves traverse through the passageway **23** to the endplate **28**. The plurality of expansion waves **102i**, **102j**, and **102k** all start simultaneously from the trailing edge **20b** of inlet port **20** and pass through passageway **23** to define the location of the trailing edge **18b** of the outlet port **18**. The simultaneous arrival of hot to cold working fluid interface **105** at **18b** further defines the location of the trailing edge **18b** of the outlet port **18**. In another form of the present invention the outlet port **18** is closed earlier so as to allow for the passage of the lower temperature working fluid along surfaces **150**. The passage of the lower temperature working fluid assists in cooling these structures. A region C within the passageway **23** comprises working fluid in a substantially quiescent state.

[0032] The continued rotation of the rotor **40** brings the passageway **23** into registration with outlet port **17**. A plurality of strong expansion waves **103i**, **103j** and **103k** (only three expansion waves shown for illustrative purposes) extend from the leading edge **17a** of outlet port **17** through the passageway **23** to the opposite endplate **29**. The contact place for the plurality of expansion waves **103i**, **103j**, and **103k** defines a range of suitable positions for the leading edge **19a** for the purge inlet port **19**. The location of the

leading edge **19a** and the pressure associated therewith will determine whether a shock wave emanates from this point through region D. In one form of the present invention reflection of the expansion waves **103i**, **103j**, and **103k** occurs at endplate **29** and the reflected waves traverse through the passageway in region D. The pressure at leading edge **19a** is dependent upon the degree to which the pressure has been reduced by the arrival of the expansion waves **103i**, **103j** and **103k**. In one form of the present invention upon the passageway **23** being brought into registration with purge inlet port **19** a shock wave (emanating from point **19a** towards point **111**) traverses through the passageway **23** and is at least partially canceled by the reflected expansion waves **103i**, **103j** and **103k** within region D. In another form of the present invention the pressure at leading edge **19a** has not been reduced to a value to allow a shock wave to emanate from this point. The expansion accomplished by waves **102** and **103** together with the work exchange occurring after the flow enters from port **20**, cause a temperature decrease of the working fluid exiting through outlet port **17**.

[0033] A hot to cold working interface is represented by dashed line **110** that separates the working fluid into a hot working fluid region D and a cooler working fluid region E. Purge working fluid is admitted from the purge inlet port **19** and upon the closure of the purge inlet port **19** a plurality of expansion waves **104i**, **104j**, **104k** and **104l** (only four shown for illustrative purposes) emanate from the trailing edge **19b** of the port. The plurality of expansion waves **104i**, **104j**, **104k**, and **104l** traverse through the passageway **23** and the hot working fluid in region D is expelled from the passageway until the hot to cold working fluid interface arrives at point **17b**. Further, the location of the trailing edge **17b** of the outlet port **17** is defined by where both the expansion waves **104** and interface **110** contact the endplate **28**. In an alternate form of the present invention the cooling of surface **151** is accomplished by retarding the closing of outlet port **17**.

[0034] With the continued rotation of rotor **40** comes the closing of the outlet port **17** which causes a shock wave **112** to traverse through the passageway **23** to compress the working fluid moving out of region E into region F. Further, the location of where shock wave **112** contacts endplate **29** defines the trailing edge **16b** of inlet port.

[0035] The described sequence of wave and gas interface motions together with the prescribed port locations setting these sequences, causes the gas entering from port **20** and having passed through the combustor/burner **13** to be substantially expelled ultimately into port **17**. A prior art device that omits port **19** allowed a large part of the gases entering from port **20** to not be expelled via port **17** but rather to move into region F. This gas then partially defeated the aforementioned self cooling feature and resulted in fluid expelled from port **18** to contain this hot fluid as a recirculating flow to the combustor **13**.

[0036] The substantial elimination of recirculation of working fluid between the combustor/burner **13** and the wave rotor **14** causes a temperature decrease in outlet port **18** in the present invention. In an alternate form of the present invention some shift in port conditions can allow the delay of the arrival of the hot or cold fluid contact **110** at point **17b** thus causing recirculation of working fluid back to the combustor/burner **13**. This may be utilized for enhanced operation, however, the degree of working fluid recircula-

tion can be controlled via port **19** flow to avoid the limitations imposed by high working fluid temperatures in transfer ducts or burner inlets.

[0037] With reference to FIG. 5, there is illustrated a wave diagram for a reverse flow type purge wave rotor topping cycle that is substantially similar to the wave diagram of FIG. 4. A reverse flow type purge wave rotor apparatus is substantially similar to the through flow type purge wave rotor that was described above. Changes to the wave rotor apparatus involve the relocation of the inlet port from burner **20** to endplate **28** and the relocation of the to purge and burner/combustor outlet port **18** to endplate **29**. The remaining ports **19**, **16** and **17** are left in the same relative location as for a through flow type forced purge wave rotor. The description of the wave and working fluid flow through the passageways **23** for the reverse flow type purge wave rotor topping cycle is substantially similar to that provided by FIG. 4.

[0038] While the invention has been illustrated and described in detail in the drawings and foregoing description, the same is to be considered as illustrative and not restrictive in character, it being understood that only the preferred embodiment has been shown and described and that all changes and modifications that come within the spirit of the invention are desired to be protected.

What is claimed is:

1. In combination:

a gas turbine engine having a compressor and a turbine; and

a wave rotor, comprising:

a rotor having a plurality of passageways therethrough for gas flow;

a plurality of sequential exit ports disposed in fluid communication with said rotor for receiving gas exiting said plurality of passageways, one of said plurality of exit ports being a first exit port having a pressure greater than the rest of said plurality of exit ports;

a plurality of sequential inlet ports disposed in fluid communication with said rotor for allowing gas to flow into said plurality of passageways, one of said plurality of inlet ports being a compressor inlet port for receiving gas from said compressor; and

a passageway coupled between said first exit port and a second of said plurality of inlet ports positioned adjacent to and prior said compressor inlet port for delivering gas to said rotor.

2. A method utilizing a wave rotor to top a gas turbine engine's cycle, comprising:

providing the wave rotor having a rotatable rotor with a plurality of fluid passageways for the passage of a working fluid therethrough;

rotating the rotor so as to sequentially pass the plurality of fluid passageways by a plurality of wave rotor inlet ports and a plurality of wave rotor outlet ports;

discharging a portion of the working fluid within at least one of the plurality of fluid passageways through one of

the plurality of outlet ports, wherein the one outlet port having the highest pressure of any of the plurality of outlet ports;

reducing the pressure of the portion of the working fluid after said discharging; and

introducing the portion of the working fluid into one of the plurality of inlet ports after said reducing.

3. A method utilizing a wave rotor to top a gas turbine engine's cycle, comprising:

providing the wave rotor having a rotatable rotor with a plurality of fluid passageways for the passage of a working fluid therethrough, the wave rotor having a plurality of outlet ports for allowing the discharge of fluid from the wave rotor and a plurality of inlet ports

for allowing the entry of fluid to the wave rotor, the outlet ports including a to-turbine port and a to-purge-and-burner port and the plurality of inlet ports including a from-burner port, a purge-inlet port and a from-compressor port;

rotating the rotor so as to sequentially pass the plurality of fluid passageways by the plurality of wave rotor ports; and

introducing a portion of the working fluid from one of the plurality of outlet ports into the purge-inlet port so as to force a substantial portion of the working fluid within the plurality of passageways into the to-turbine port.

* * * * *