

June 5, 1934.

P. GRASSMANN

1,962,012

ELECTRODYNAMIC LOUD SPEAKER

Filed April 5, 1933

3 Sheets-Sheet 1

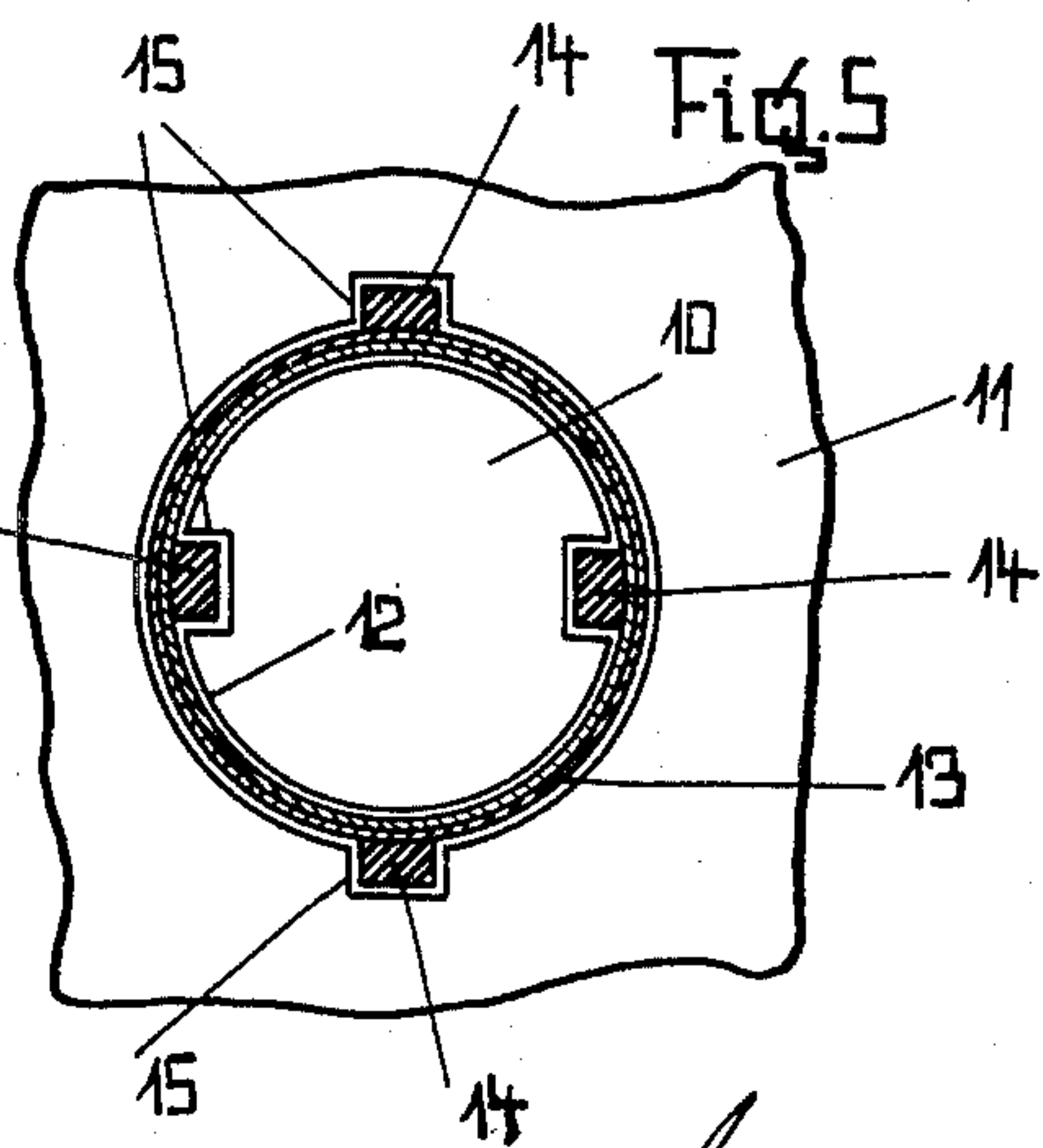
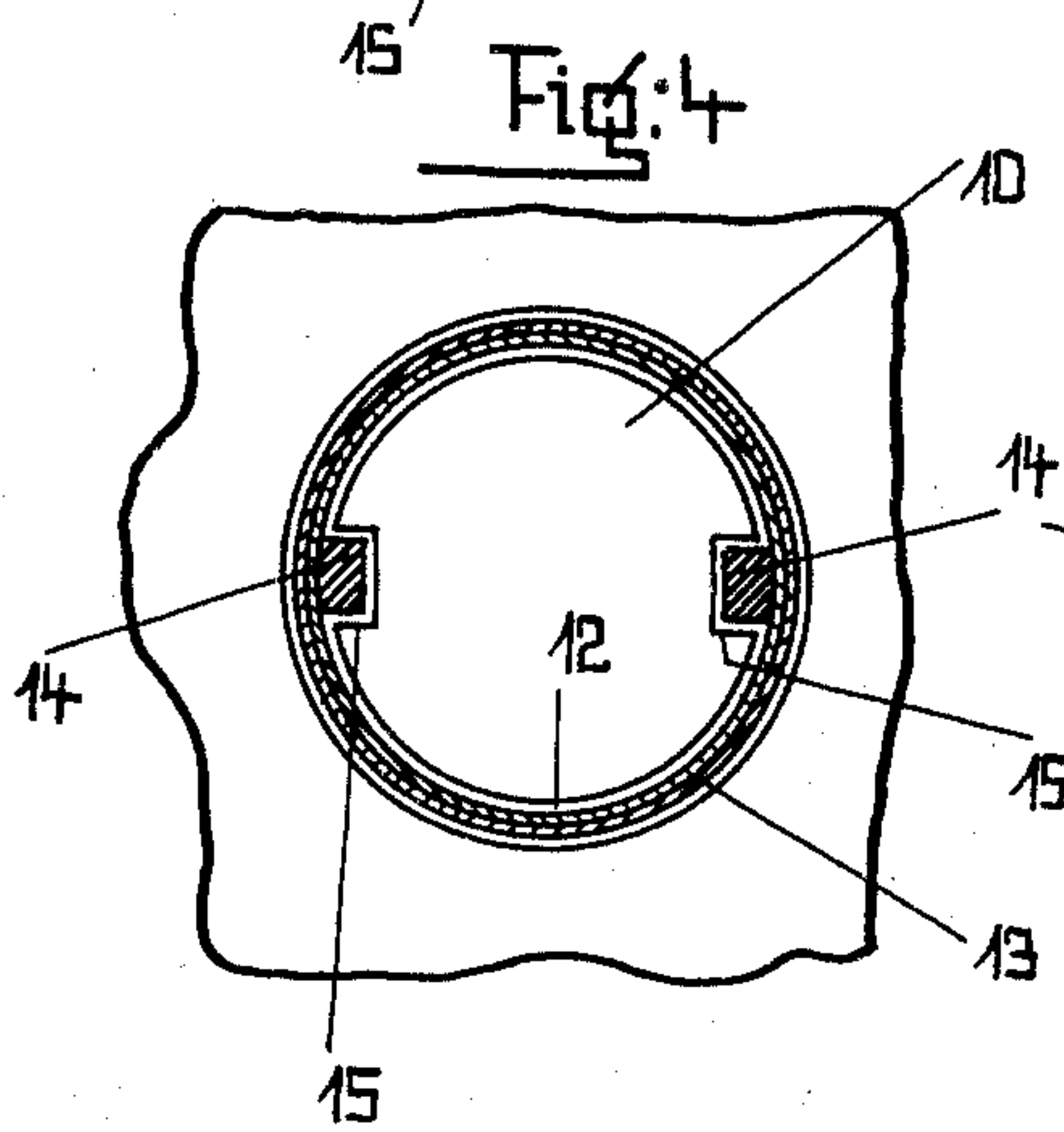
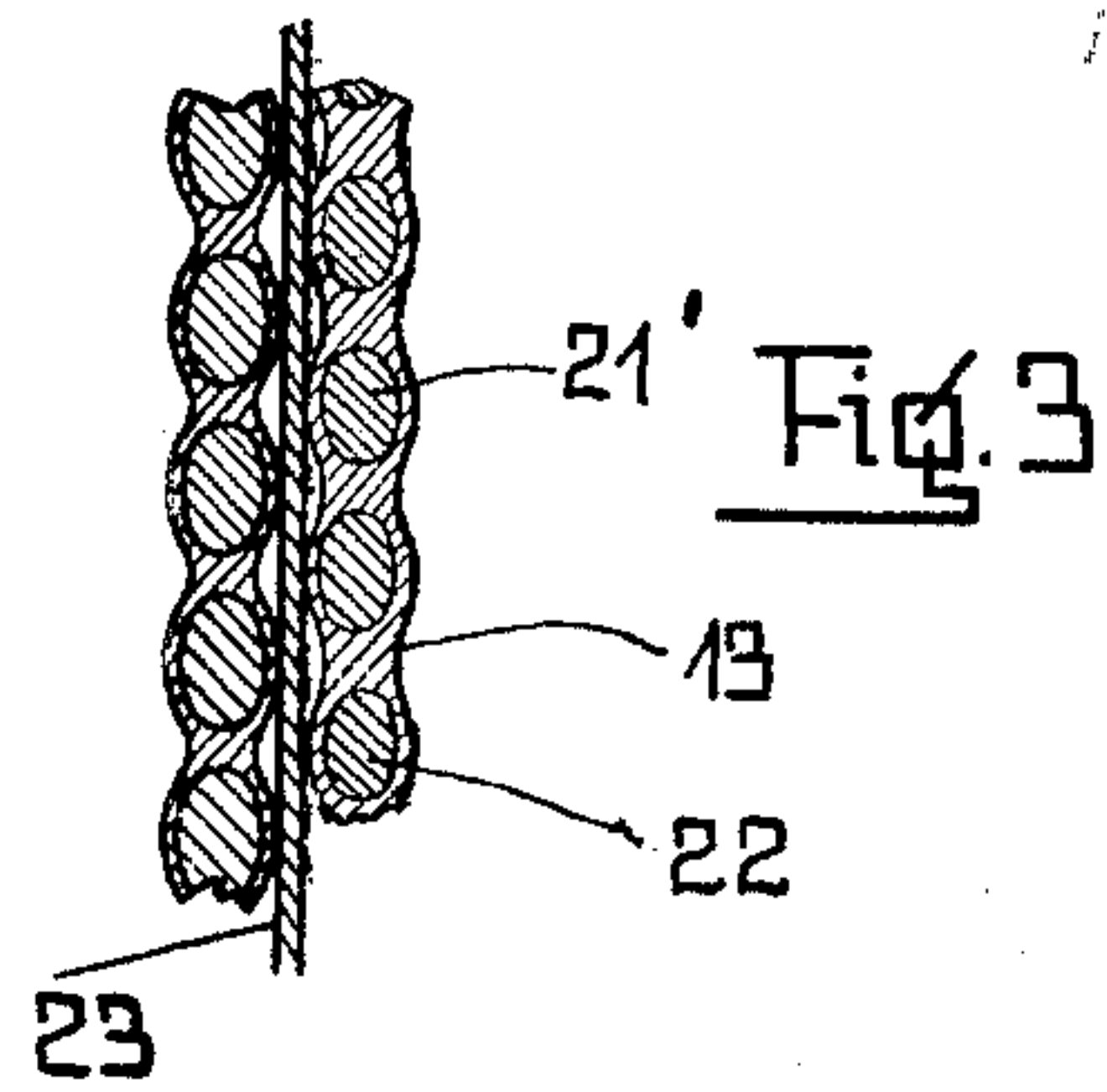
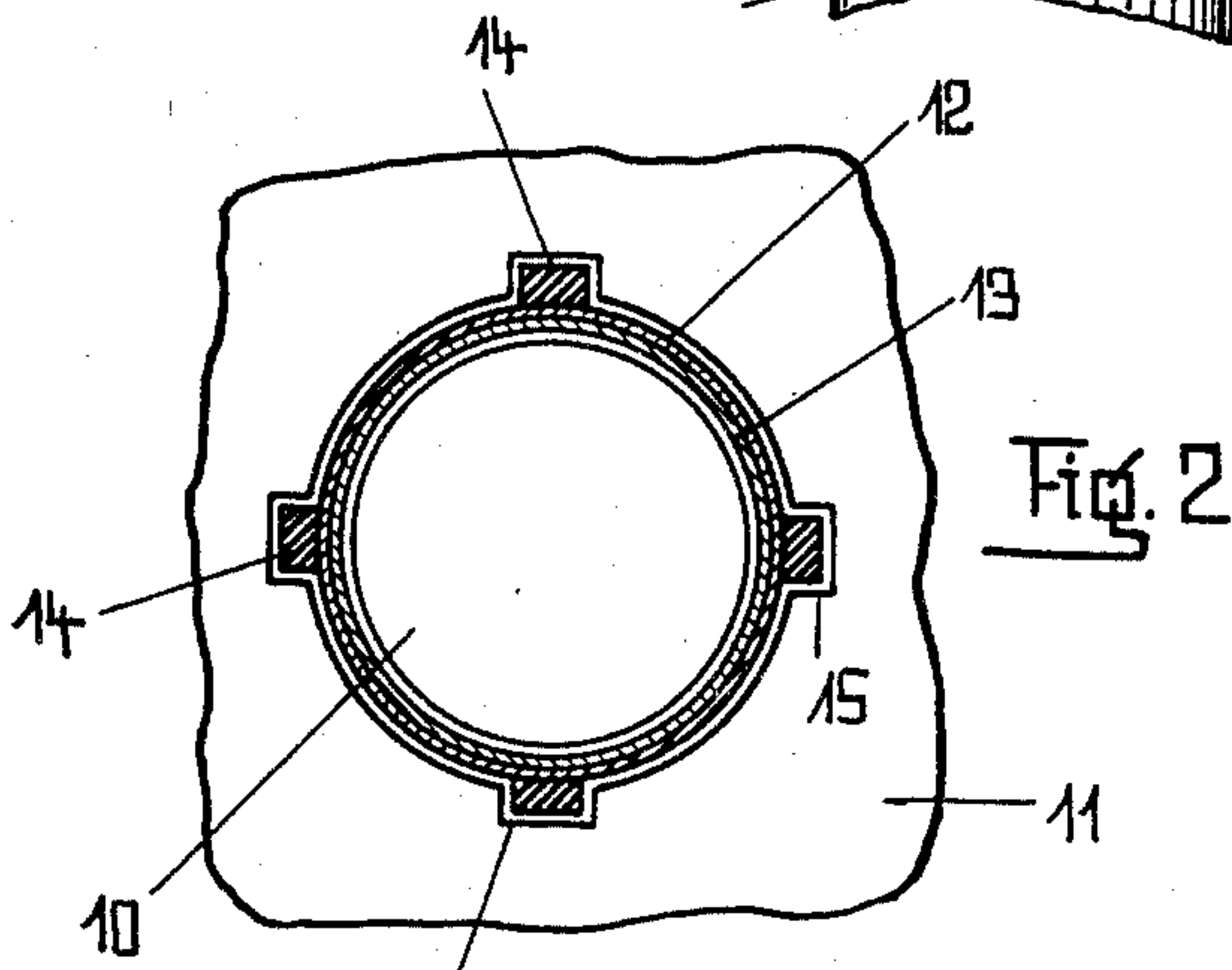
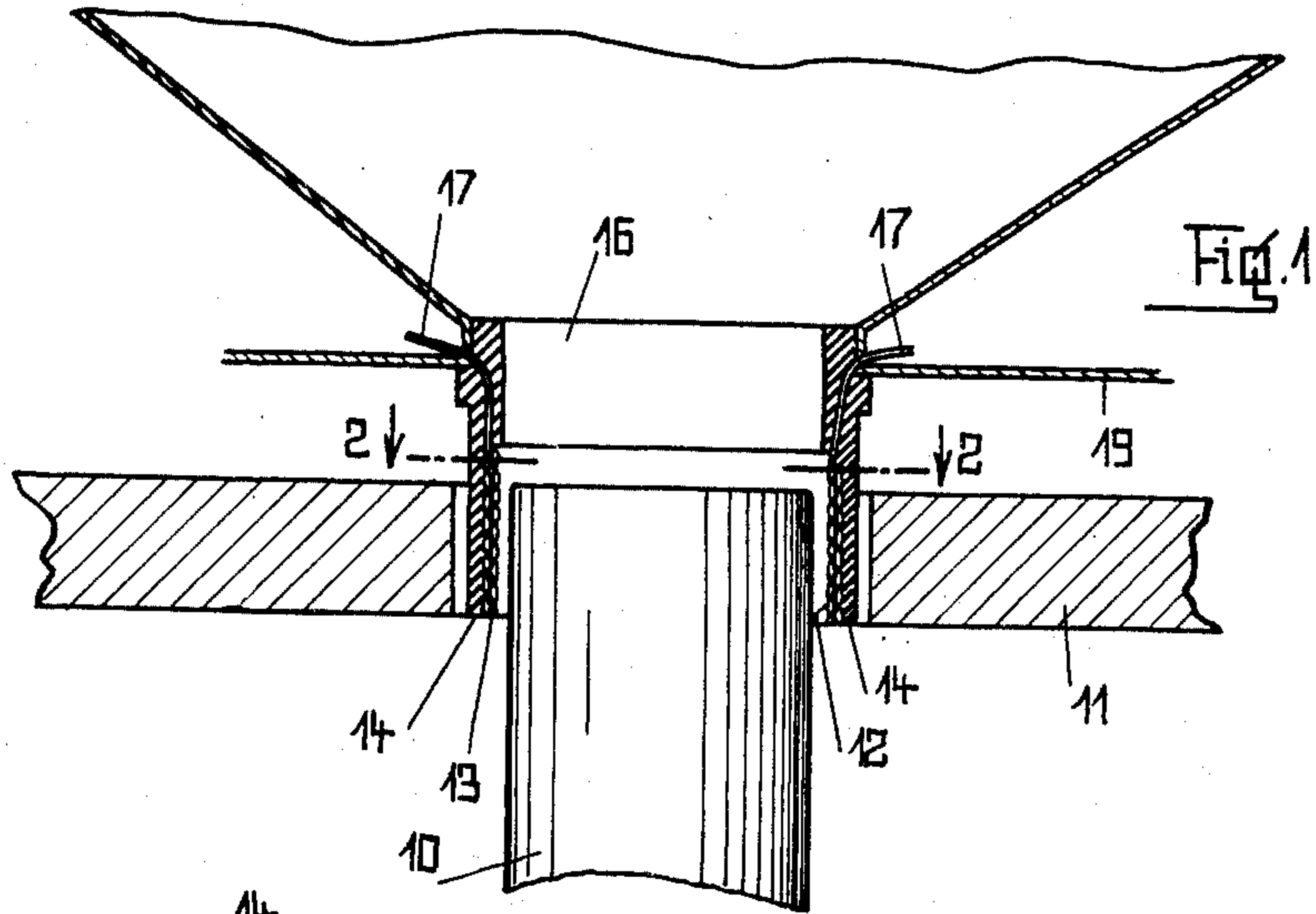

Inventor:
Peter Grassmann,
by Thomas A. Anderson
att.

June 5, 1934.

P. GRASSMANN

1,962,012

ELECTRODYNAMIC LOUD SPEAKER

Filed April 5, 1933

3 Sheets-Sheet 2

Fig. 6

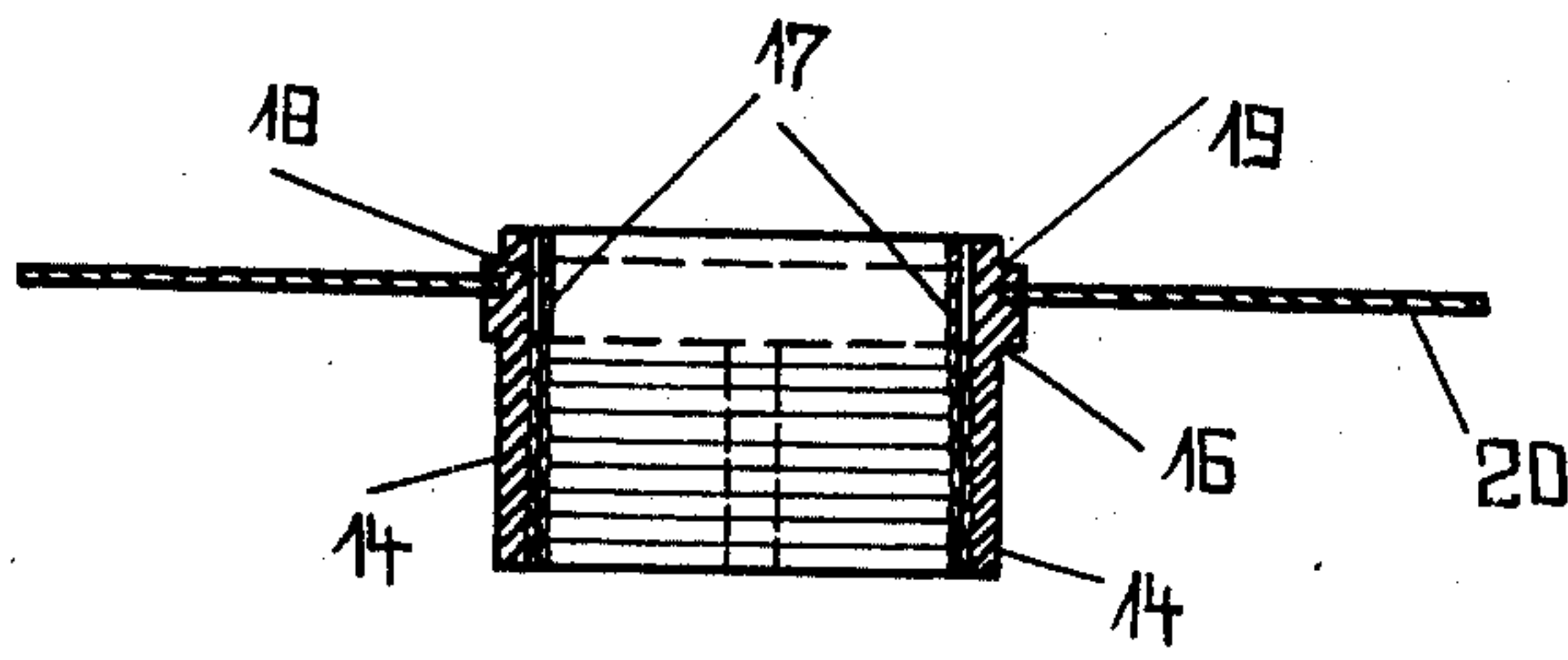

Fig. 8

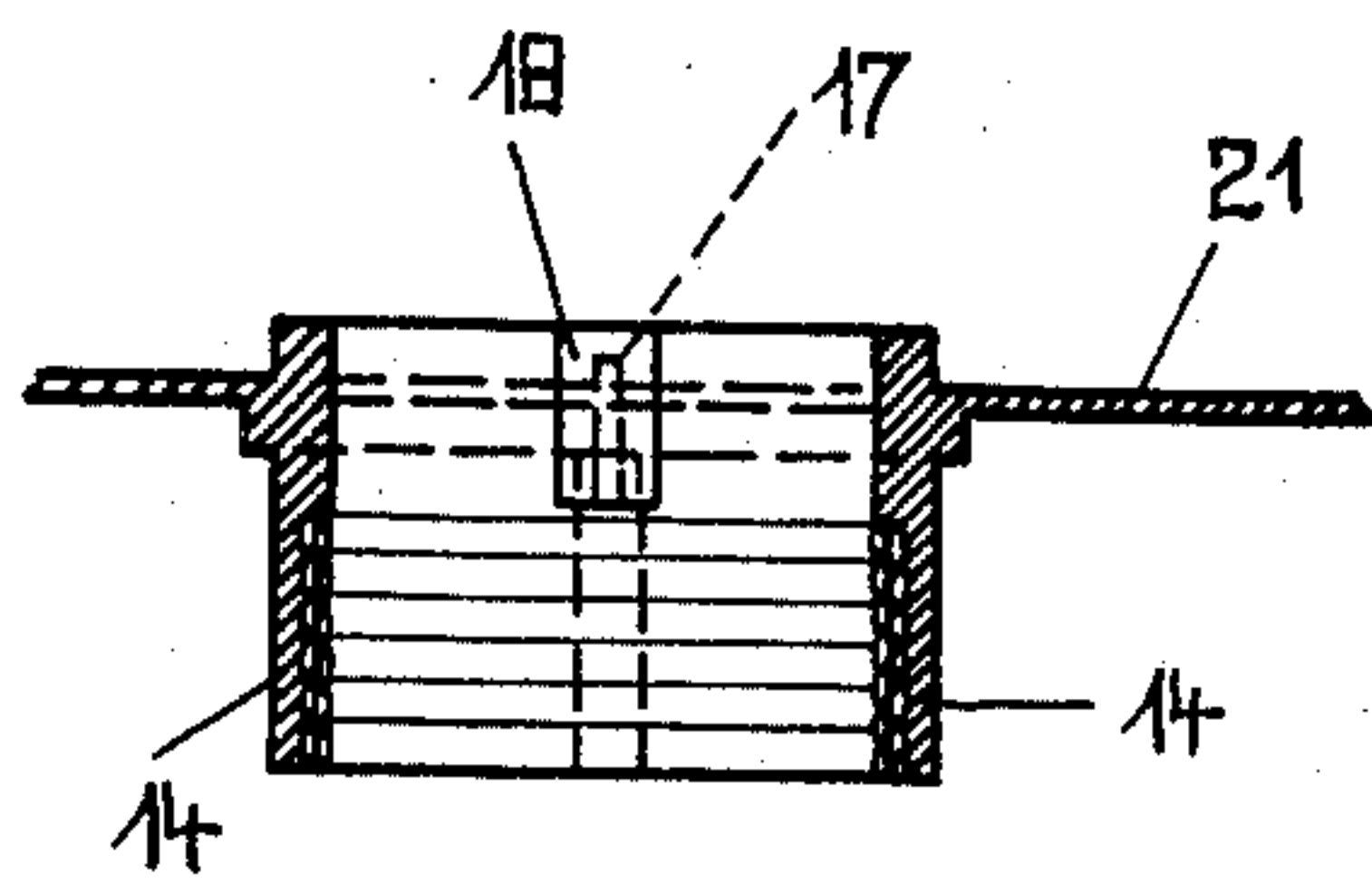

Fig. 7

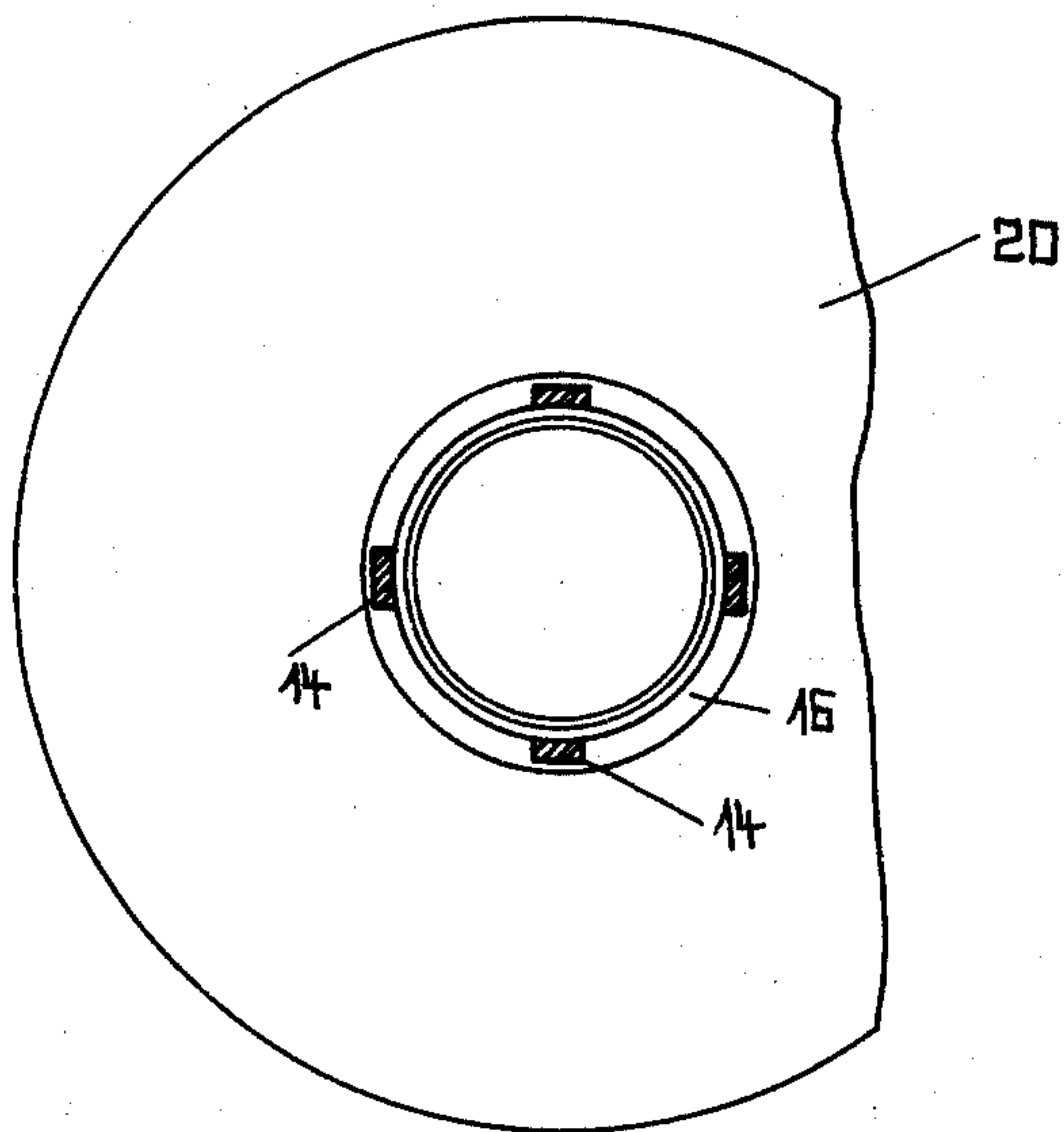
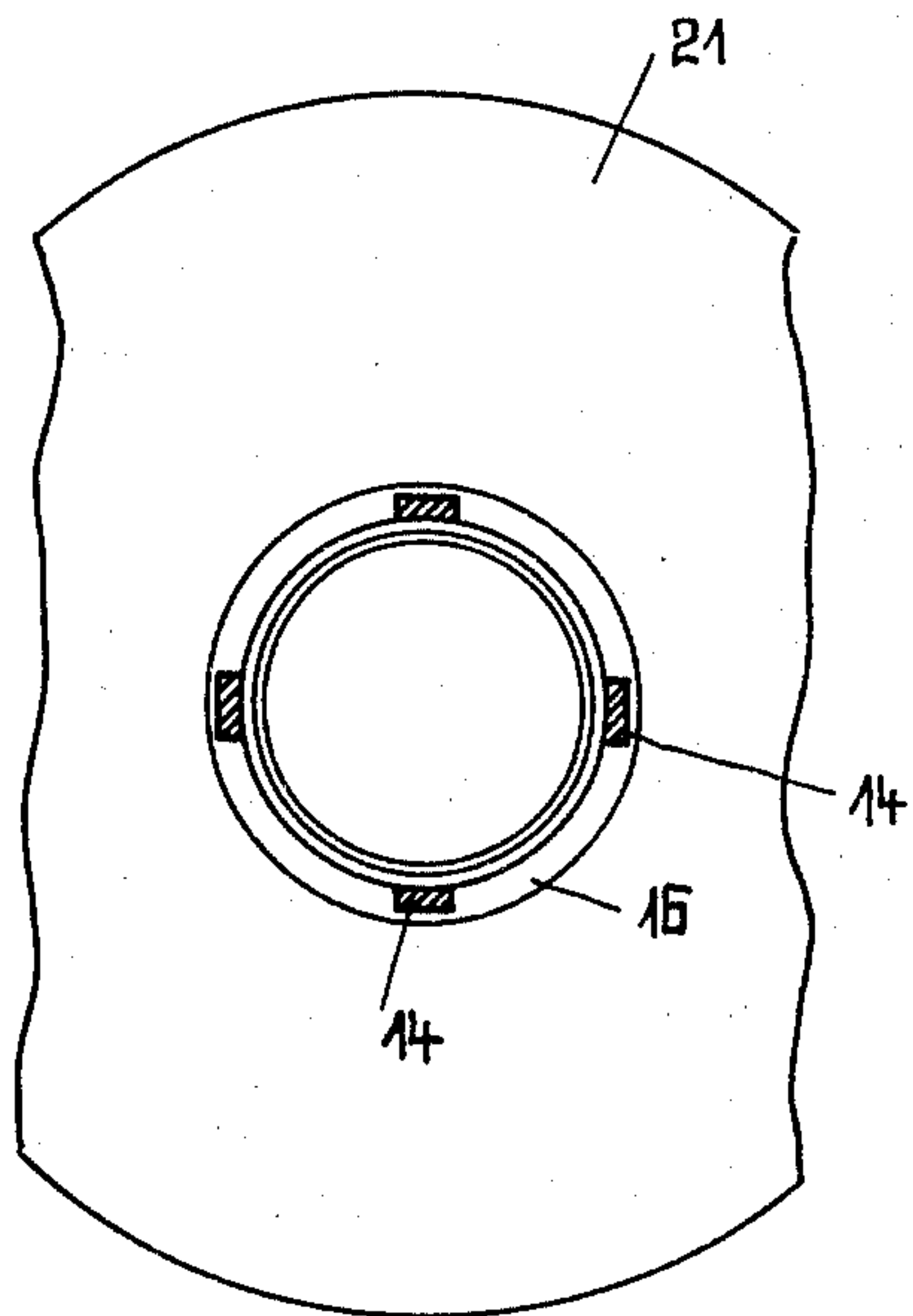

Fig. 9



Inventor:
Peter Grassmann,
by *Thmas. Appelman*
Att'y

June 5, 1934.

P. GRASSMANN

1,962,012

ELECTRODYNAMIC LOUD SPEAKER

Filed April 5, 1933

3 Sheets-Sheet 3

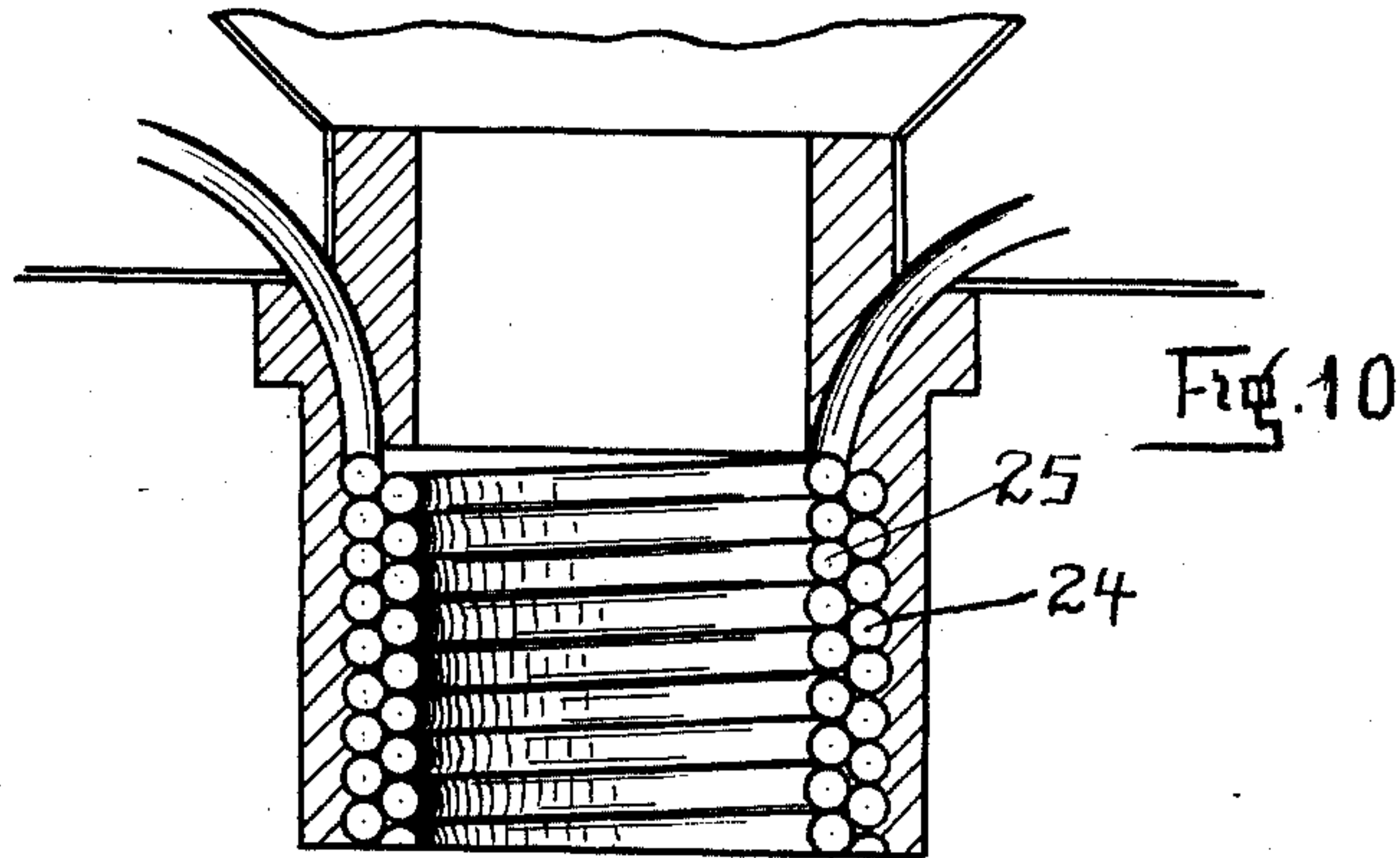

Fig. 10

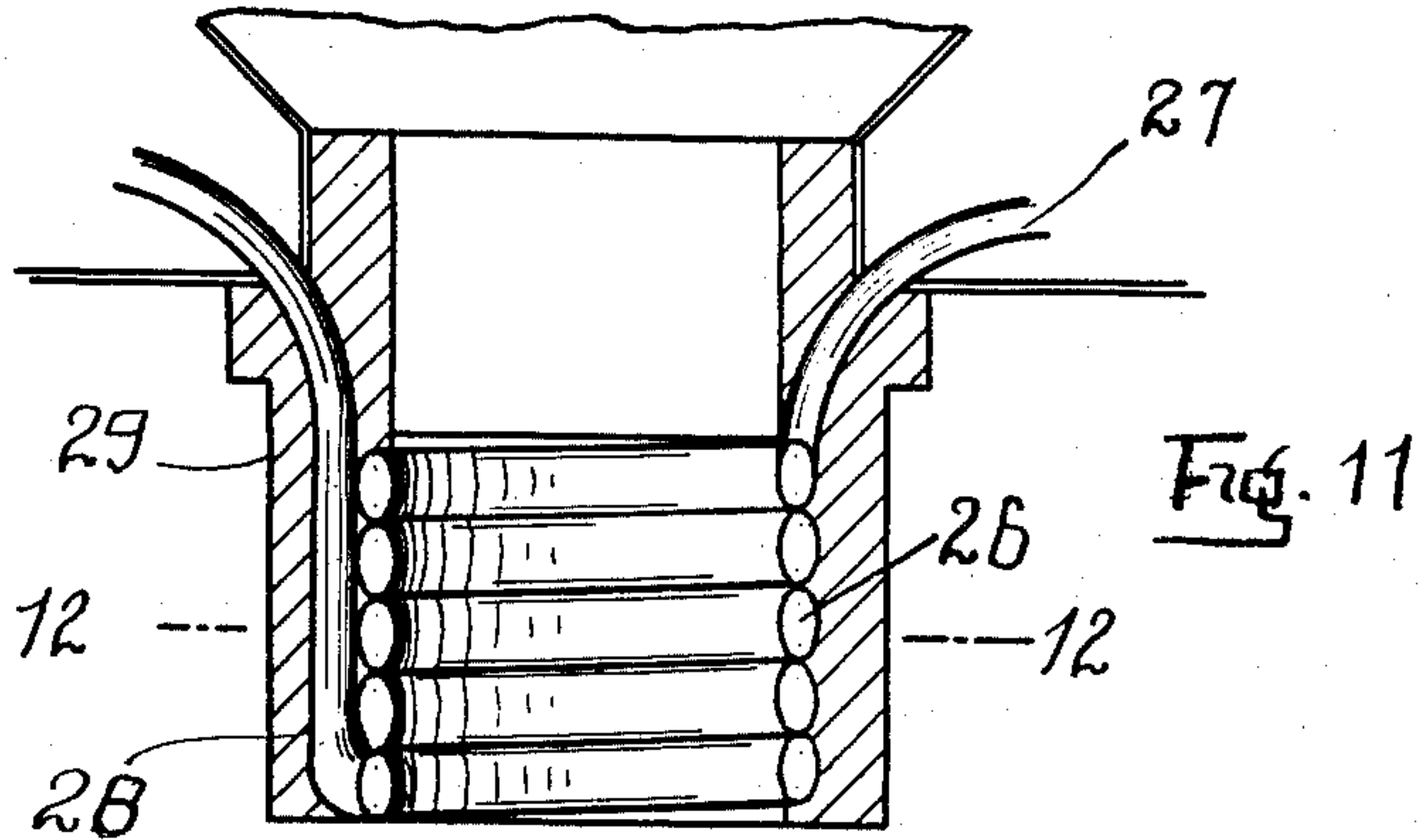

Fig. 11

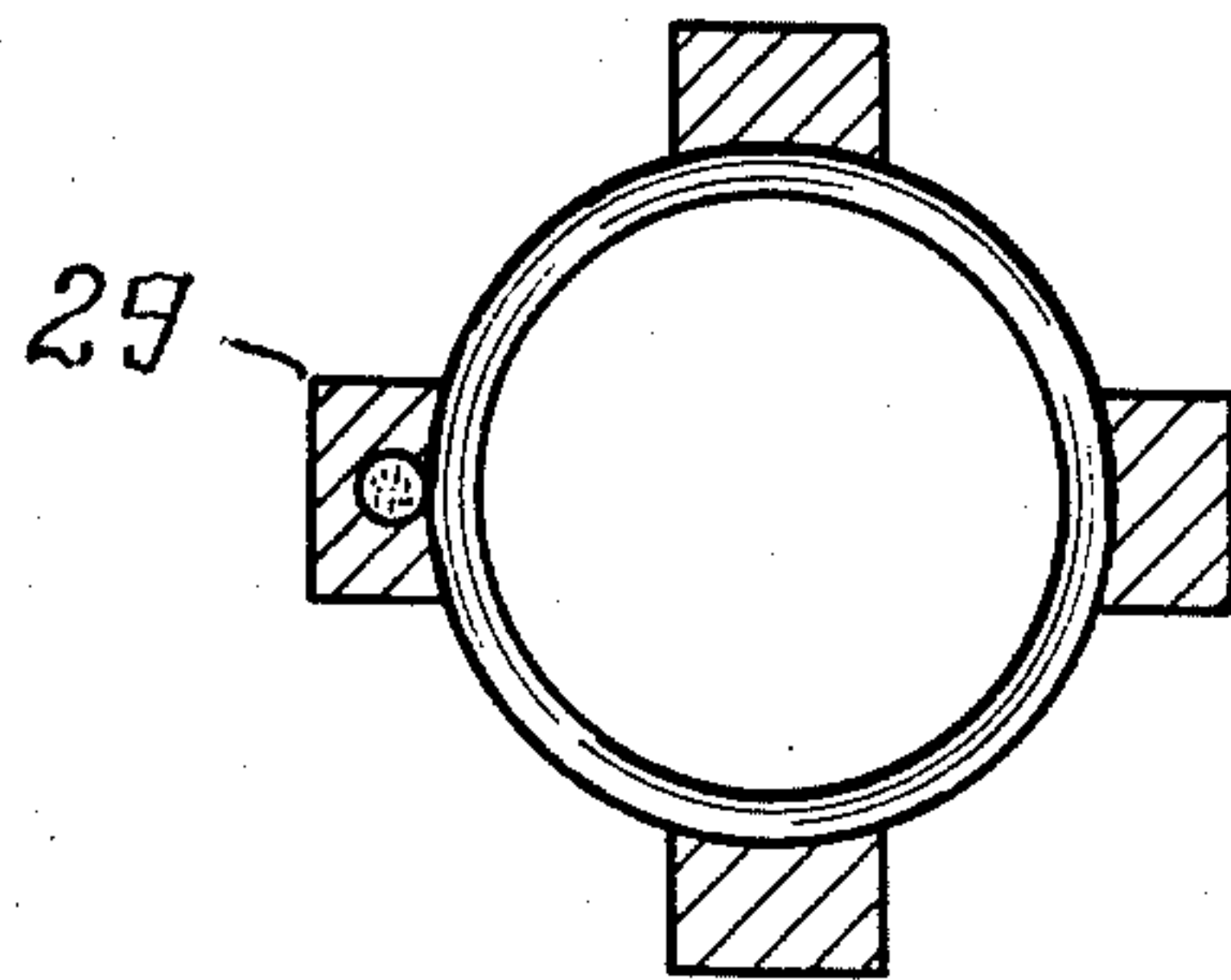

Fig. 12

Inventor:
Peter Grassmann
by Frank Appelman,
Atty.

UNITED STATES PATENT OFFICE

1,962,012

ELECTRODYNAMIC LOUD SPEAKER

Peter Grassmann, Berlin-Lichterfelde, Germany

Application April 5, 1933, Serial No. 664,613

In Germany April 9, 1932

12 Claims. (Cl. 179—115.5)

This invention relates to electro-dynamic loud speakers and has special reference to an oscillatory coil for such loud speakers.

In the construction of electro-dynamic loud speakers, it is common to provide a magnet having one pole in the form of a cylinder and the other pole of annular or ring shape surrounding the end of the first pole and concentrically spaced therefrom. These poles may, for convenience, be termed the core pole and the ring pole respectively. With this construction an annular gap is provided between these poles and in this gap is supported the oscillatory coil of the device. This coil has the diaphragm of the loud speaker suitably connected thereto and the oscillations of the coil, effected by current variations impressed thereon, correspondingly effect oscillations of the diaphragm. The coil is thus subjected to oscillation stresses of very considerable magnitude which tend to disrupt the coil windings. Accordingly, suitable means must be provided to support such coil windings so that they may retain their shape under the oscillation stresses developed in use and so that the wire may not be broken.

It is a well recognized fact that, for the greatest possible magnetic efficiency in a device of this sort and in order to prevent dispersion of and loss in the magnetic field between the magnet poles, the gap between such poles must be the least possible having due consideration to freedom for oscillation of the coil in this gap. Hitherto, it has been customary to support the coil windings on a tubular core but there is a considerable loss of efficiency in this arrangement since the magnet gap or pole gap must be of sufficient width to accommodate both the tubular support or body and the coil windings.

It has been proposed to eliminate the space in the pole gap necessary to permit use of the support by making the coil windings self-supporting so that no tubular support is necessary. As one method of making self-supporting windings it has been proposed to hold the convolutions of the winding together by a suitable cementing material, such as insulating varnish. This is open to the serious objection that the coil thus formed lacks the requisite strength to retain its shape under the high oscillation stresses developed in use. It has also been proposed to use cylinders consisting of thin metal layers wound upon one another and suitably insulated from each other, the layers being held in position by suitable cementitious material. This is also not satisfactory because of the limit-

ed number of convolutions possible with such construction without widening the pole gap while effective operation of such oscillatory coils requires a considerable number of such convolutions.

One important object of the invention is, therefore, to provide an improved construction of oscillatory coils for this purpose by means of which the effective width of the pole gap will depend solely upon the thickness of the coil windings.

A second important object of the invention is to provide an improved oscillatory coil wherein the windings will be strongly supported in place by novel means which will not appreciably interfere with the maintenance of a pole gap of minimum width.

A third important object of the invention is to provide an improved coil of this type wherein the coil itself is wound from suitable wire to permit the thickness of the formed coil to be considerably reduced from those formed with the usual wire of circular cross section.

In the design of coils for this purpose, it is frequently desirable that the windings be disposed in an uneven number of layers and, since it is desirable that both terminals of the winding lie at the same end, it is necessary to lead one terminal from one end to the other of the coil.

A fourth important object of this invention is to provide an improved construction of such coils wherein such a terminal wire may be led from one end to the other of the coil without interfering with the pole gap and in such manner that it is supported against possible rupture.

Inasmuch as the wire used in these coils is commonly of small gage and therefore liable to fracture, it is a further object of the invention to provide, in such a coil, a novel arrangement for the attachment of connecting wires to the coil, the arrangement being such as to require no manipulation of the coil wire itself while such attachment is being effected.

With the above and other objects in view, as will be apparent from the detailed description of the invention presently to be given, the invention consists in general of certain novel details of construction and combinations of parts hereinafter more fully described, illustrated in the accompanying drawings, and set forth in the claims.

In describing the invention in detail, reference will be had to the accompanying drawings forming part of this application wherein like

characters denote corresponding parts in the several views, and in which—

Figure 1 is a detail section taken diametrically through a loud speaker embodying one form of the invention;

Figure 2 is a section on the line 2—2 of Figure 1;

Figure 3 is an enlarged detail section of a modified coil winding;

Figure 4 is a section similar to Figure 2 showing a modification of the arrangement of supporting ribs used herein;

Figure 5 is a view similar to Figure 4 but showing a second modified arrangement of ribs;

Figure 6 is a section taken diametrically through a modified arrangement of coil;

Figure 7 is a bottom plan view of the coil shown in Figure 6;

Figure 8 is a section similar to Figure 6 but at right angles thereto and showing a still further modification of the coil arrangement; and

Figure 9 is a bottom plan view of the coil shown in Figure 8.

Figure 10 is a sectional view showing the windings staggered.

Figure 11 is a sectional view of a coil having one layer with the ends of the wire leading from the top and bottom of the coil.

Figure 12 is a sectional view of a coil on the line 12—12 of Figure 11.

In the several embodiments of the invention herein illustrated, there are shown the cylindrical pole 10 and the annular pole 11 of the magnet common to devices of this character, these poles being concentrically spaced to provide an annular pole gap 12.

The improved oscillatory coil is formed with windings 13 and may be constructed in the usual manner by winding suitably insulated wire on a mandrel or core. Extending longitudinally of the wound coil are ribs 14 which are suitably spaced around the coil and have the coil firmly attached thereto. For instance, the coil and the mandrel or core whereon it is wound may be placed in a suitable mold in which the coil closely fits and which is provided with grooves corresponding in shape and position to the desired ribs. Then, a suitable plastic insulation, such as the condensation product known as bakelite may be forced into the grooves in its plastic state and allowed to set or harden. When constructed in this manner, the coil and ribs will form a unitary structure. The number of ribs used may be that found best adapted for the particular construction and these ribs may be all on the outside of the coil as shown in Figure 2, all on the inside as shown in Figure 4 or on both the outside and the inside of the coil.

The width of the pole gap 12 for this coil is just sufficient to allow free oscillation of the coil and grooves 15 are formed in the proper magnet pole or poles to receive these ribs as clearly shown in Figures 2, 4 and 5. At the upper or outer end of the coil these ribs are preferably connected to a ring 16 of insulating material which lies entirely outside of the pole gap. This ring is preferably molded with the ribs so that the ring, the ribs and the windings form a unitary structure.

As shown in Figure 1, the terminals 17 of the winding may be led up the ribs and out through the outside of the ring 16 or the terminal ends 17 may be led up along the inside of the ring against the mandrel and terminal con-

nections 18 of flat metal, such as copper or brass foil molded into place against them, as shown in Figures 6 and 8, thus making solid attaching means for lead in wires.

The ring may be supported from a carrier element 19 as in Figure 1 or from either a carrier element or diaphragm 20 as in Figure 6. Also the ring may have such carrier element molded thereon as at 21 in Figure 8.

In Figure 3 is shown a winding wherein the wire 21' is flattened in a direction radial to the coil and insulated by suitable varnish 22, a paper or thread wrapping 23 being interposed between successive layers and the wires of one layer being arranged in staggered relation to the wires of the adjacent layer.

In Figure 10 the coil is formed by a winding arranged in layers 24 and 25 in which the wire of one layer is in staggered relation to the wire of the other layer.

In Figure 11, the coil is shown as having a single layer 26 and one of the wire ends 27 is at the top of the coil whereas the other wire end 28 is at the bottom of the coil and the said wire end extends through a rib 29.

I claim

1. An oscillatory coil for magnetic loud speakers including a coil winding, and circumferentially spaced ribs extending longitudinally of the coil winding and supporting the coil winding against deformation.

2. An oscillatory coil for magnetic loud speakers including a coil winding, and circumferentially spaced ribs extending longitudinally of the coil winding and supporting the coil winding against deformation; in combination with a magnet having concentric poles spaced to form a pole gap in which said coil winding is located, at least one of said poles having slots therein to receive said ribs.

3. An oscillatory coil for magnetic loud speakers including a coil winding and circumferentially spaced ribs extending longitudinally of the coil winding and supporting the coil winding against deformation, the terminal ends of said wires extending along the coil within said ribs.

4. An oscillatory coil for magnetic loud speakers including a coil winding, circumferentially spaced ribs extending longitudinally of the coil winding and supporting the coil winding against deformation, and a ring at the upper end of the coil winding having the ribs rigidly connected thereto.

5. The coil of claim 1 characterized by having ribs molded thereon.

6. An oscillatory coil for magnetic loud speakers including a coil winding, and circumferentially spaced ribs extending longitudinally of the coil winding and supporting the coil winding against deformation, the wire forming the coil being flattened radially thereof.

7. An oscillatory coil for magnetic loud speakers including a coil winding, and circumferentially spaced ribs extending longitudinally of the coil winding and supporting the coil winding against deformation, the wire forming the coil being flattened radially thereof and having the convolutions of one layer staggered with respect to the convolutions of the next layer.

8. An oscillatory coil for magnetic loud speakers including a coil winding, and circumferentially spaced ribs extending longitudinally of the coil winding and supporting the coil winding against deformation, the wire forming the coil

80

85

90

95

100

105

110

115

120

125

130

135

140

145

150

being flattened radially thereof and having the convolutions of one layer staggered with respect to the convolutions of the next layer, said coil having an insulating wrapping interposed between adjacent layers.

5 9. An oscillatory coil for magnetic loud speakers including a coil winding, circumferentially spaced ribs extending longitudinally of the coil winding and supporting the coil winding against deformation, and a ring at the upper end of the coil winding having the ribs rigidly connected thereto, the terminals of the wire forming the coil being embedded in the surface of the ring and having its ends covered by metal foil exposed on the surface of the ring to form attaching means for circuit wires.

10 10. An oscillatory coil for magnetic loud speakers including a coil winding and circumferentially spaced ribs extending longitudinally of the coil winding and supporting the coil winding against deformation; in combination with a magnet having concentric poles spaced to form a pole gap in which said coil winding is located, at least one of said poles having slots therein to receive said ribs, a ring at the upper end of the coil winding having the ribs rigidly connected thereto, and a supporting member associated with the ring to hold the coil concentrically of the magnet poles within the pole gap.

15 20 25 30 11. An oscillatory coil for magnetic loud speak-

ers including a coil winding and circumferentially spaced ribs extending longitudinally of the coil winding and supporting the coil winding against deformation; in combination with a magnet having concentric poles spaced to form a pole gap in which said coil winding is located, at least one of said poles having slots therein to receive said ribs, a ring at the upper end of the coil winding having the ribs rigidly connected thereto, and a supporting member associated with the ring to hold the coil concentrically of the magnet poles within the pole gap, said supporting member being embedded at its central portion in said ring.

12. An oscillatory coil for magnetic loud speakers including a coil winding and circumferentially spaced ribs extending longitudinally of the coil winding and supporting the coil winding against deformation; in combination with a magnet having concentric poles spaced to form a pole gap in which said coil winding is located, at least one of said poles having slots therein to receive said ribs, a ring at the upper end of the coil winding having the ribs rigidly connected thereto, and a supporting member associated with the ring to hold the coil concentrically of the magnet poles within the pole gap, said supporting member being formed integrally with said ring.

PETER GRASSMANN.

80

85

90

95

100

105

110

115

120

125

130

135

140

145

150

35

40

45

50

55

60

65

70

75