

May 9, 1933.

H. L. GREVE

1,908,667

CARDBOARD BOX

Filed Jan. 14, 1931

Fig. 1.

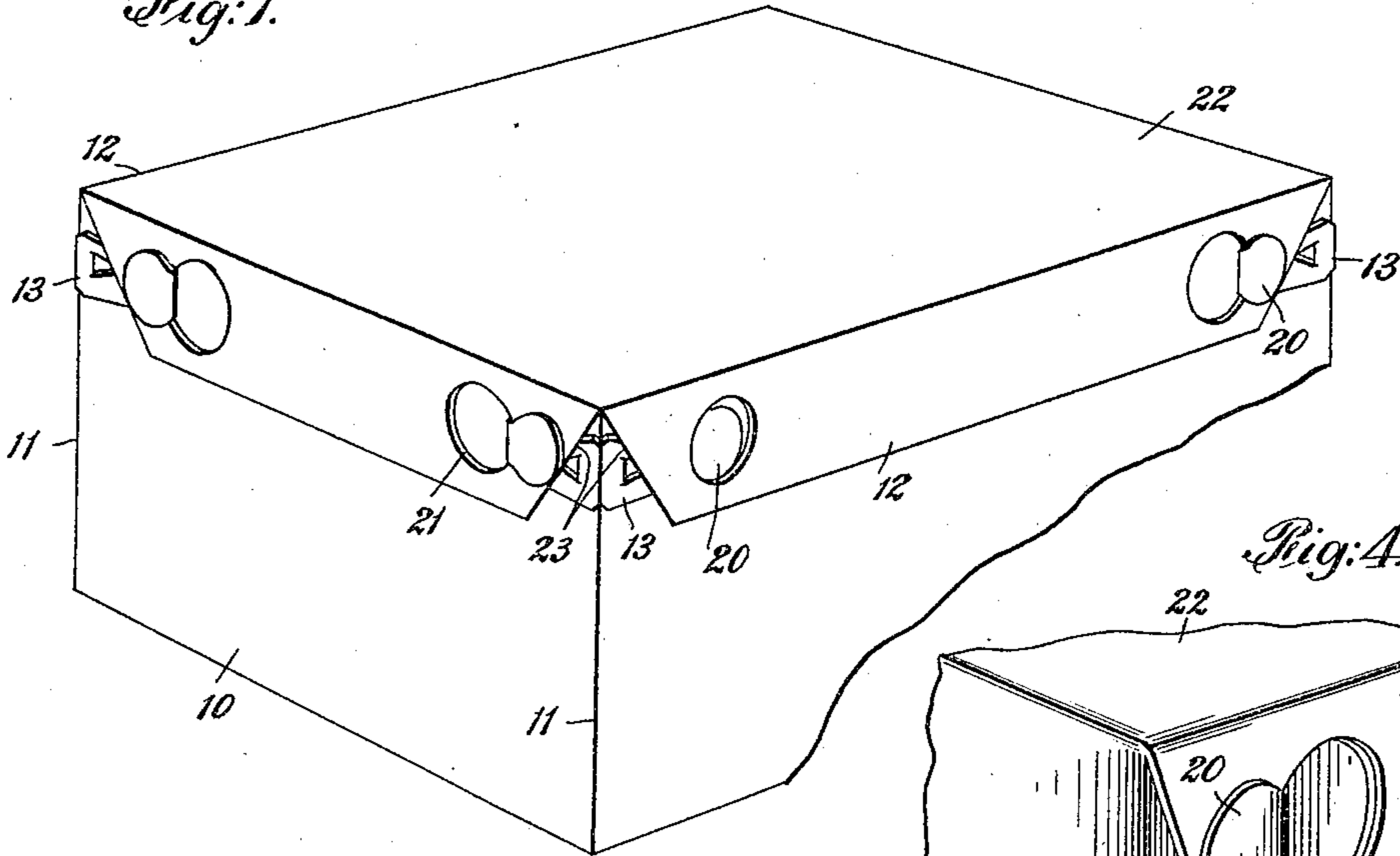

Fig. 4.

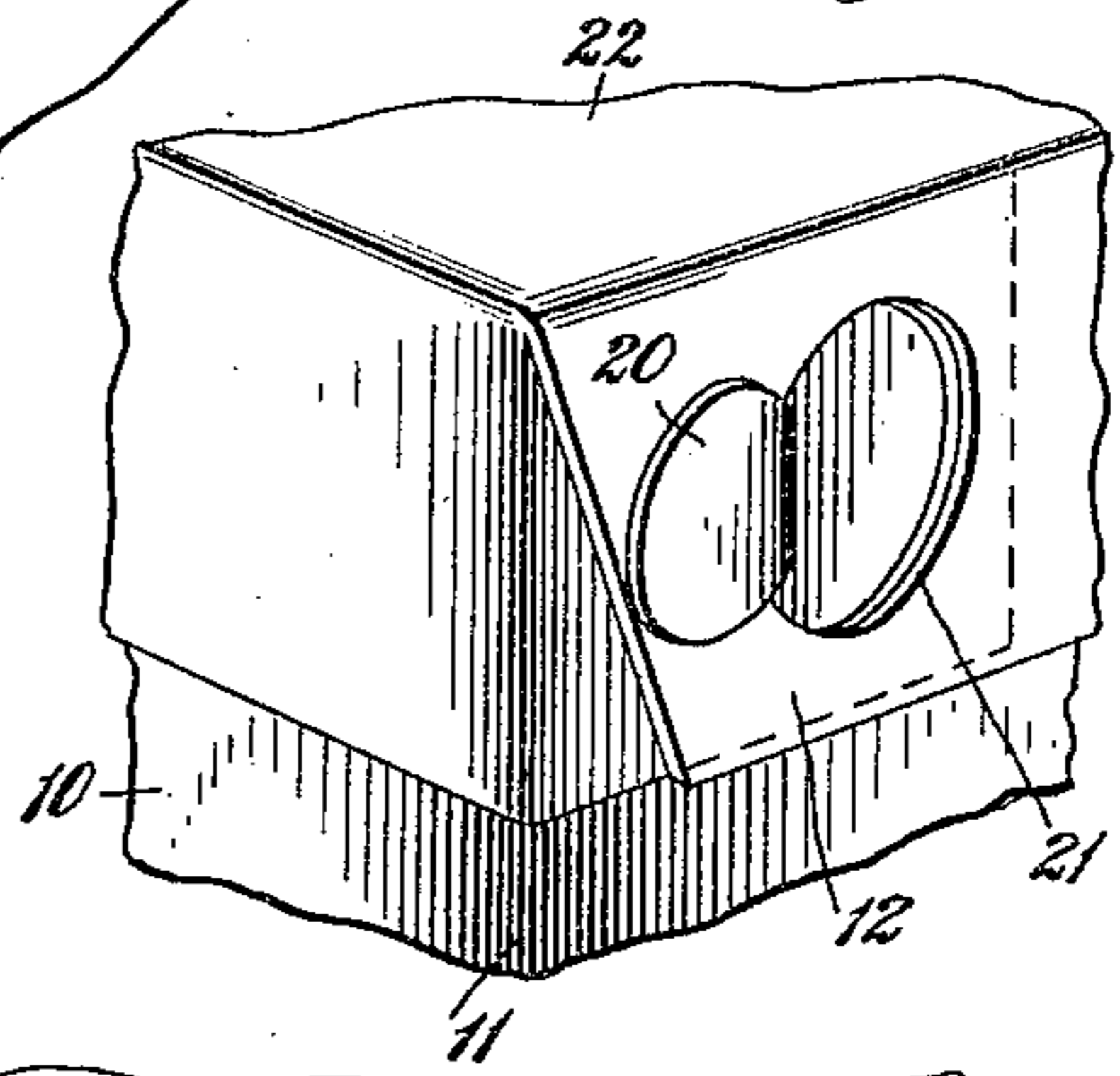

Fig. 2.

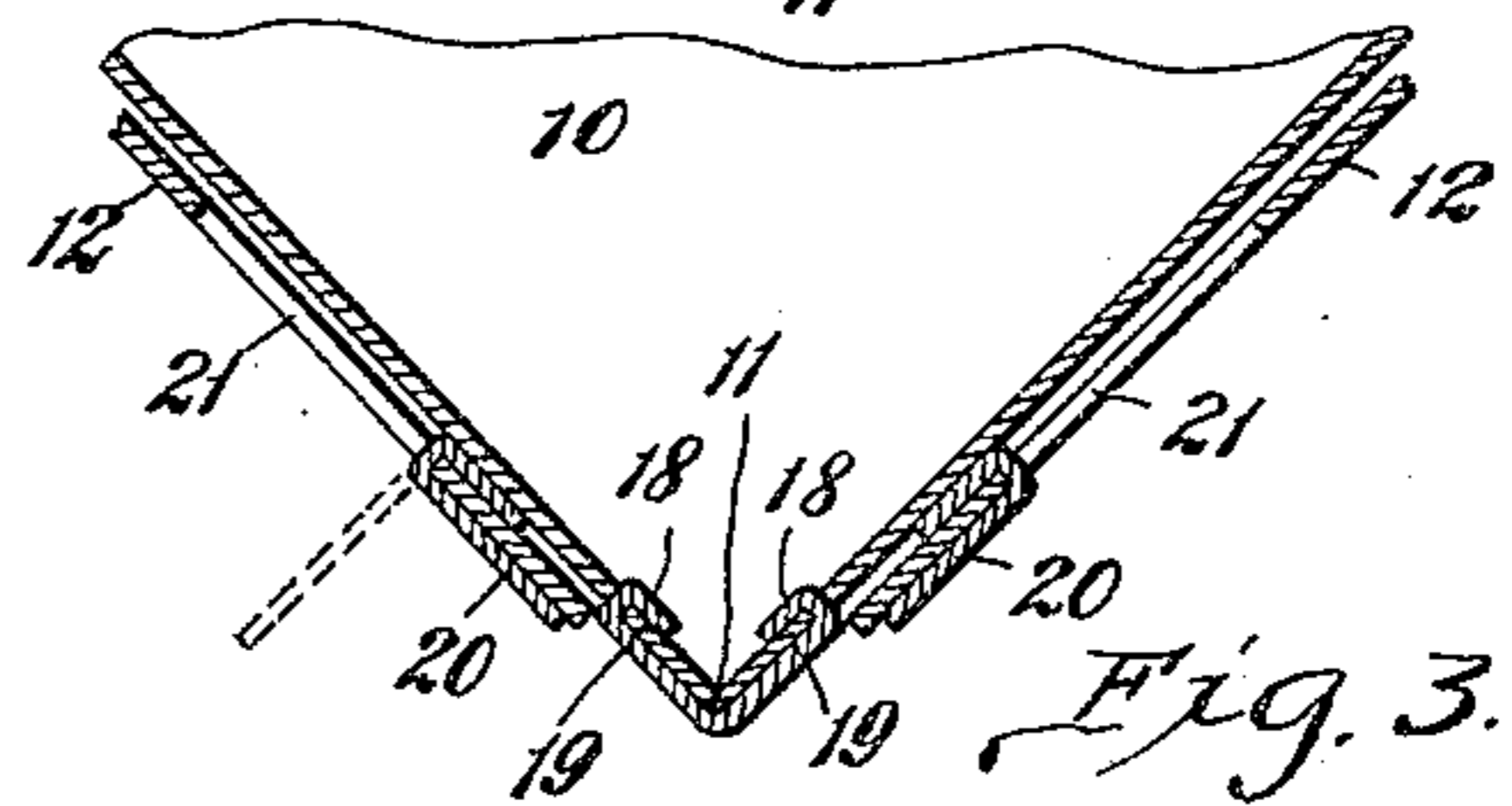
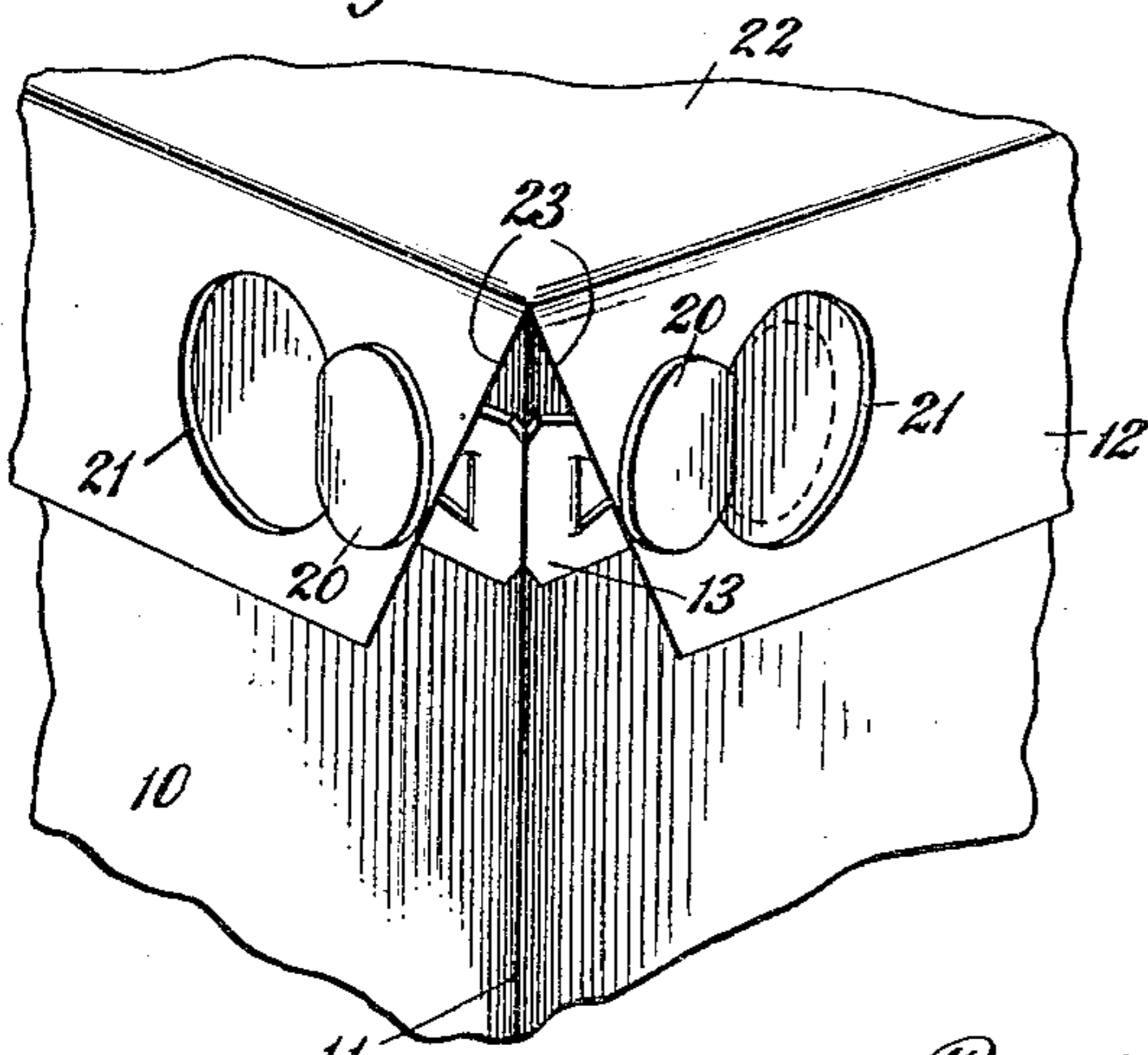

Fig. 3.

Fig. 5.

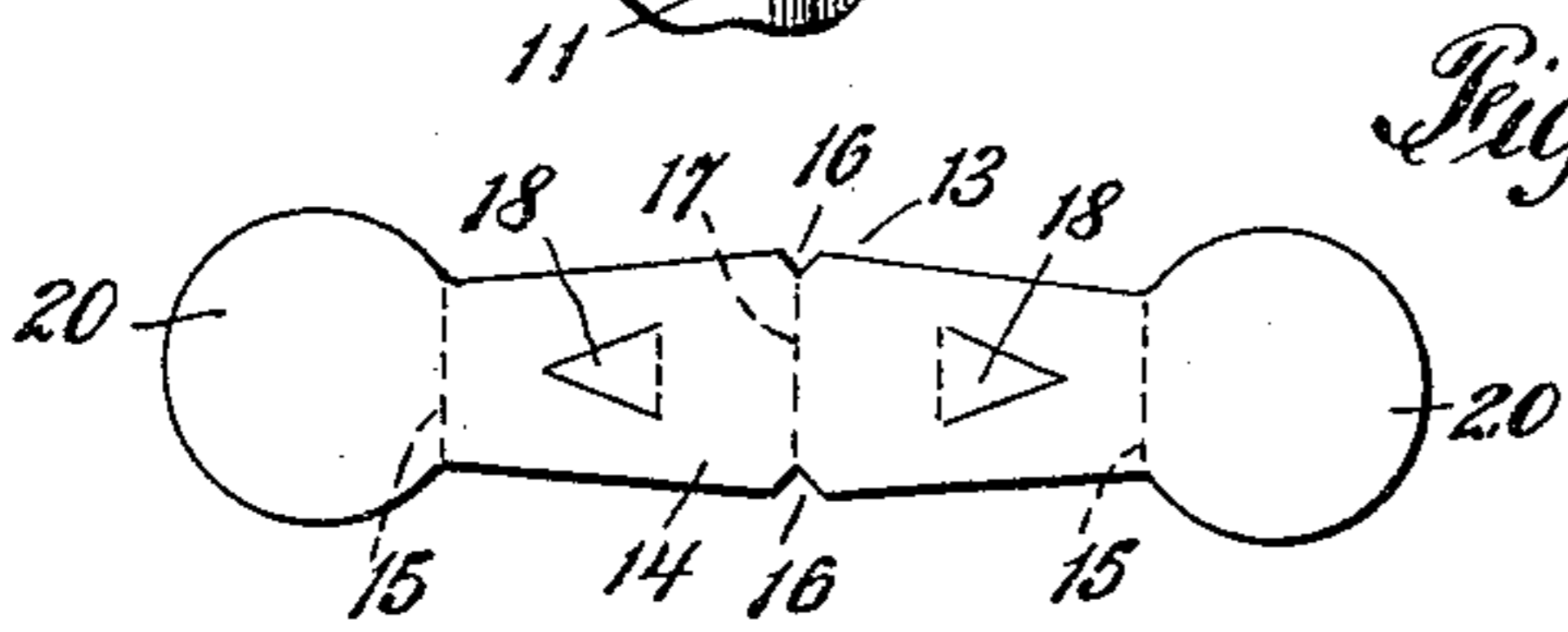

Fig. 7.

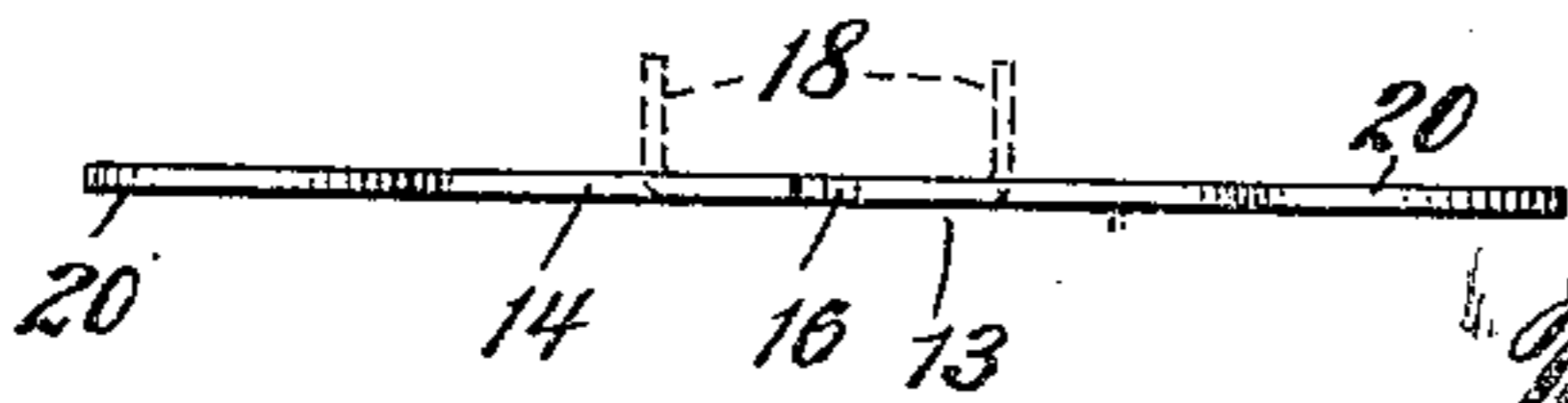
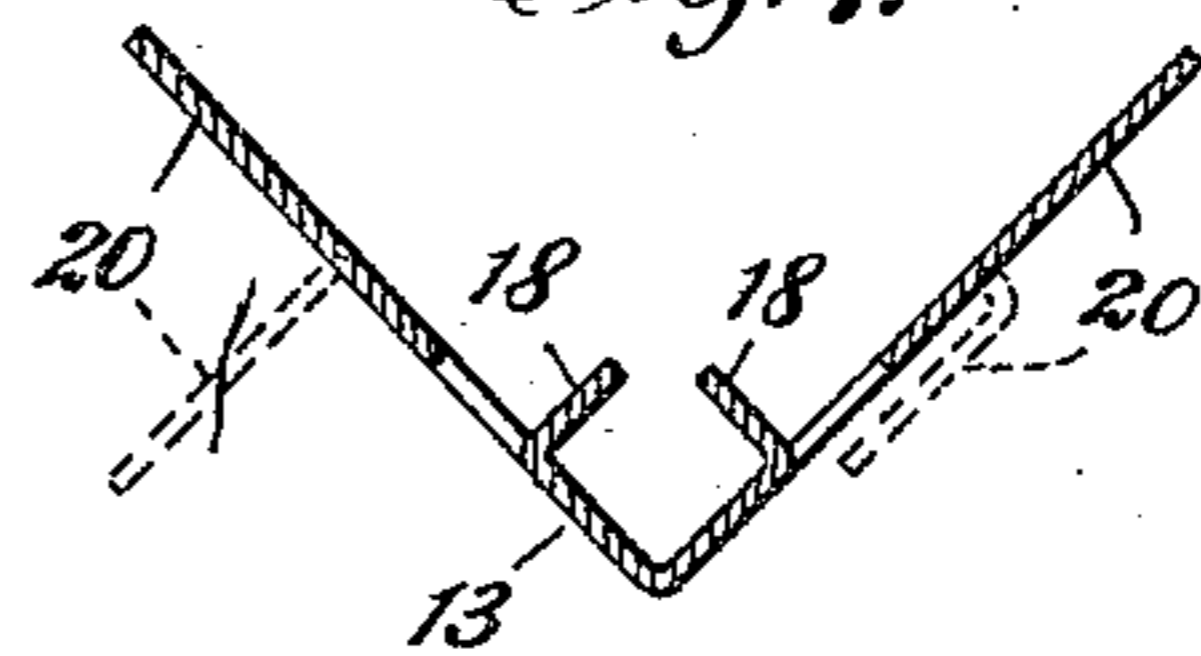

Fig. 6.

Herman L. Greve  
INVENTOR  
BY Frank W. Ashley  
ATTORNEY

# UNITED STATES PATENT OFFICE

HERMAN L. GREVE, OF HOLLIS, NEW YORK, ASSIGNOR TO INTERNATIONAL MAILING TUBE AND WRAPPER COMPANY, OF LONG ISLAND CITY, NEW YORK

## CARDBOARD BOX

Application filed January 14, 1931. Serial No. 508,648.

My invention relates to cardboard and similar boxes of the type that are erected from flat pliable sheet material.

The object of my invention is to provide a box of this character having a cover and detachable metal clips which serve to hold the box in its erected form, reinforce the corners of the box and, at the same time, cooperate with portions of the cover to removably secure the cover in closed position on the box.

Fig. 1 is a perspective view of a cardboard box constructed for use with my clip which is shown mounted thereon.

Fig. 2 is a perspective view of one corner of the box showing a clip mounted thereon and holding a cover in position on the body portion.

Fig. 3 is a sectional plan view of the corner of the box, with a clip fastened thereon and locking the cover portion to the body portion of the box.

Fig. 4 is a perspective view of the corner of the box showing the construction in which one end of the clip only will be used to hold the cover in position on the body portion of the box.

Fig. 5 is a front view of the clip.

Fig. 6 is a plan view of the clip.

Fig. 7 is a plan sectional view of the clip, dotted lines illustrating the ends of the clip being bent relative to the middle or body portion thereof.

10 indicates the body portion of the cardboard box and 11 the corners thereof.

12 indicates the cover portion which may be made to fit over the top of the body portion 11 which is illustrated in Figures 1, 2 and 4.

13 indicates a clip made of soft metal such as brass or copper or thin sheet iron and is preferably formed as illustrated in Figure 5, and is provided by stamping the clip from a sheet of metal by punch and die operations.

The body portion 14 of the clip extends from the middle to the dotted lines 15 and is provided with a notch 16 at each side of the body portion to weaken the cross section at this point, so that it may be easily bent on the line 17 to the form illustrated in Figure 7.

Where the clip is made of rather thick metal, I prefer to score the clip on the line 17 to insure its bending perfectly along this line, or in the act of fitting it in position on the body of the box as illustrated in Figures 1 and 2, and may also score the metal along the lines 15 to permit it to bend more easily in the act of securing the cover of the body portion in position, as illustrated in Figure 2.

Fastening means 18 for holding the clip to the body portion of the box, are provided by stamping the fastening means in the shape illustrated, from the body portion of the clip, and are bent inward as illustrated in Figure 7, to permit them to be forced through the wall of the box and clinched on the inner side thereof as illustrated at 19 in Figure 3, to hold the side walls in erected relationship, and at the same time to serve as a strengthening means for the corner of the box at this point. The free ends 20 of the clip are passed through openings 21 formed in the flange portion of the cover as illustrated in Figure 2 to secure the cover to the body portion, as will be readily understood.

Figure 4 shows a modification in the construction of the flange portion of the box, the cover being formed with the flat portion 12' which extends around the corner of the box, and the end portion 20 of the clip extends through an opening 21 and is bent over as is illustrated to hold the cover in position by the use of one end of the clip only.

The top 22 of the box is provided with the downwardly extending flat portions 12 and the adjacent edge portions 23 may be cut away to provide a V shaped space as illustrated in Figure 1 or the edge portion 23 may extend to the corner 11 of the box and thus cover the body portion 13 of the clip from view.

By the use of this clip which permits the ends 20 to be bent back and forth a number of times before it will break, the cover 12 may be easily removed from the body portion 10 for inspection of the contents of the box, in a convenient and time saving manner.

Having thus described my invention I claim as new:

1. A box erected from flat pliable sheet material, a detachable metal strip surrounding and reinforcing a corner of the box and fastened to adjacent side walls thereof to hold the box walls in erected relationship, a cover for said box having a downwardly extending flat portion provided with an opening therethru and arranged to overlie a free end of said strip, the free end of said strip being bendable outwardly thru the opening in said cover portion to removably secure the cover in closed position on the box.

2. A box erected from flat pliable sheet material, a detachable metal strip surrounding and reinforcing a corner of the box and fastened intermediate its ends to the adjacent side walls thereof to hold the box walls in erected relationship, a cover for said box having downwardly extending flat portions provided with openings therethru and adapted to overlie the free ends of said strip, the free ends of said strip being bendable outwardly thru the openings in said cover portions to removably secure the cover in closed position on the box.

3. A box erected from flat pliable sheet material, a detachable metal strip surrounding and reinforcing the corners of the box, each strip being fastened to the side walls of the box adjacent its respective corner to hold the box walls in erected relationship, a cover for said box having downwardly extending flat portions provided with openings therethru and arranged to overlie the free ends of said strips, the free ends of said strips being bendable outwardly thru the openings in said cover portion to removably secure the cover in closed position on the box.

In testimony whereof I have affixed my signature.

HERMAN L. GREVE.

45

50

55

60

65