

May 9, 1933.

H. E. ELLIS

1,908,590

APPARATUS FOR PRODUCING PULP WITHOUT HEAT

Filed Dec. 19, 1929

4 Sheets-Sheet 1

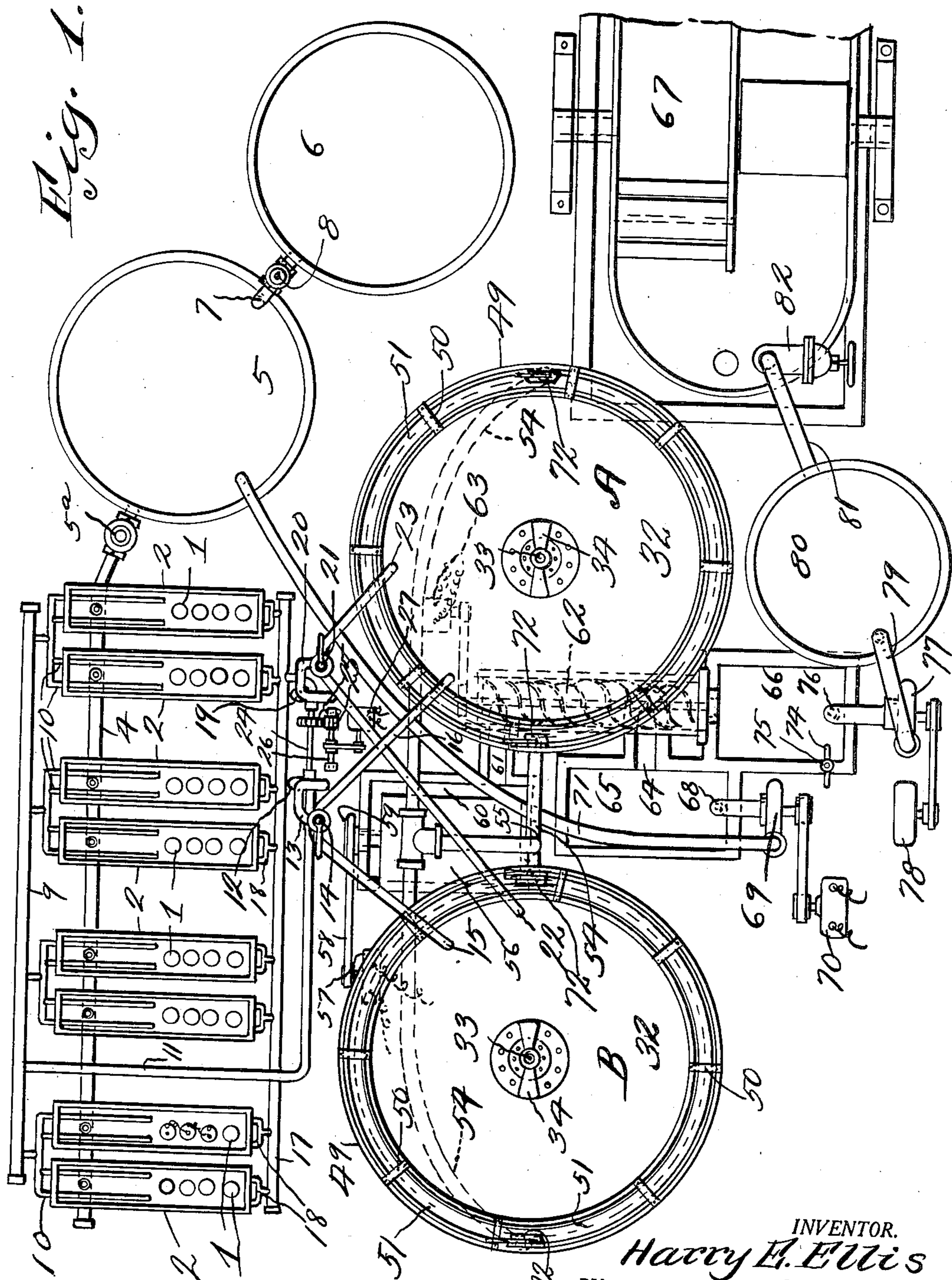

INVENTOR.  
Harry E. Ellis  
BY  
Philip A. S. Mill  
ATTORNEY.

May 9, 1933.

H. E. ELLIS

1,908,590

APPARATUS FOR PRODUCING PULP WITHOUT HEAT

Filed Dec. 19, 1929

4 Sheets-Sheet 2

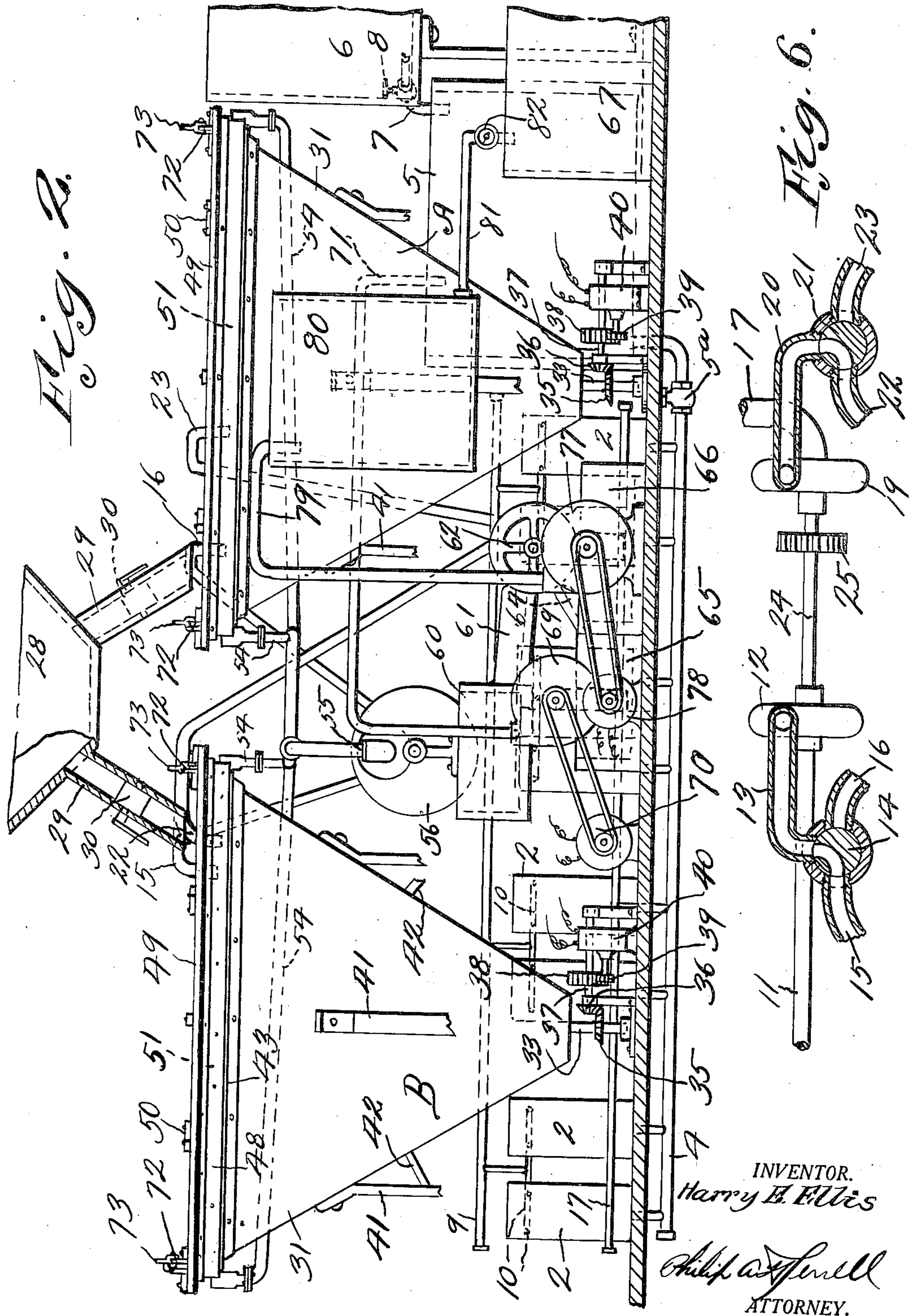

INVENTOR.  
Harry E. Ellis

Philip A. Farrell  
ATTORNEY.

May 9, 1933.

H. E. ELLIS

1,908,590

APPARATUS FOR PRODUCING PULP WITHOUT HEAT

Filed Dec. 19, 1929

4 Sheets-Sheet 3

*Fig. 3.*

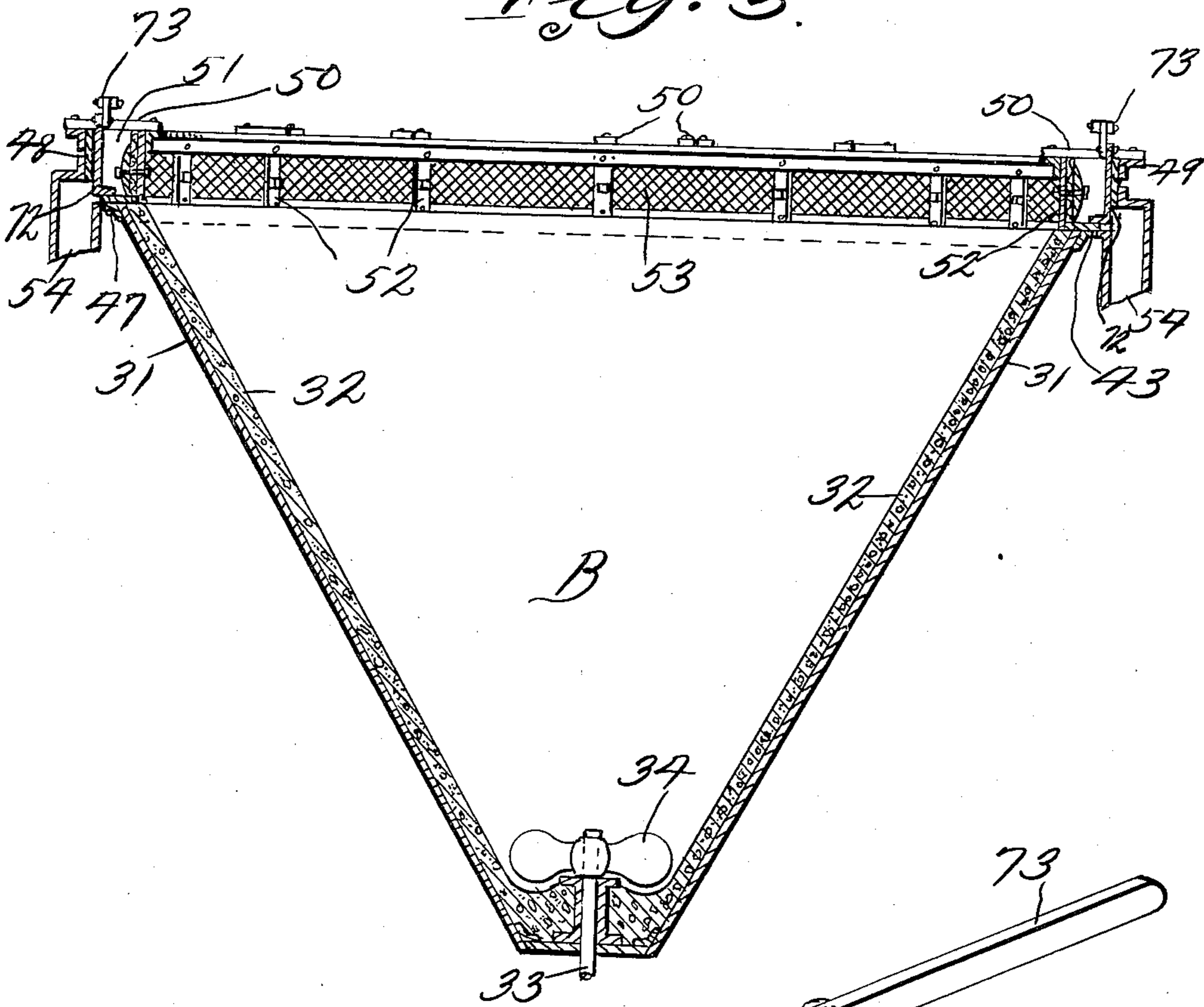

*Fig. 4.*

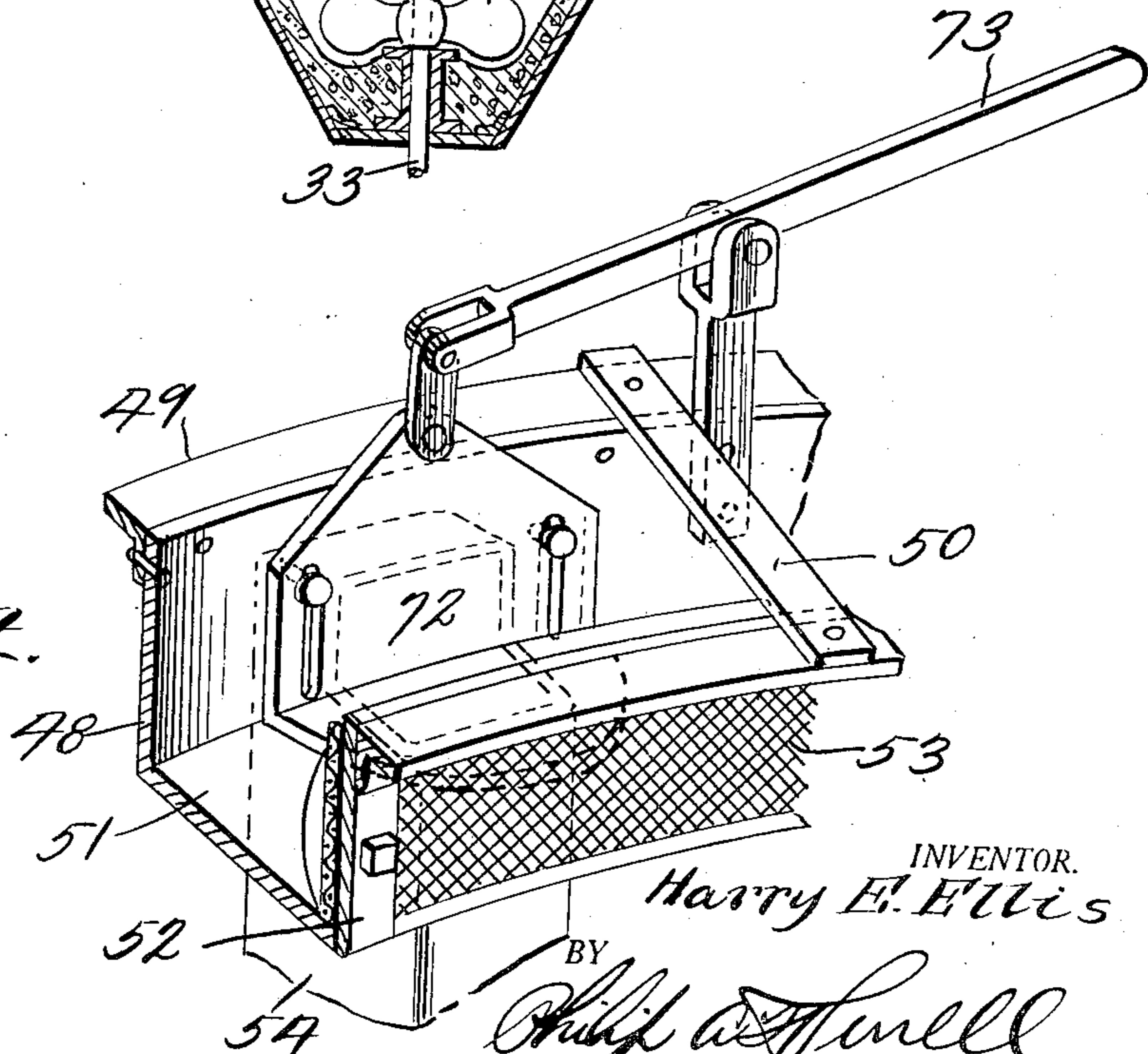

INVENTOR.  
*Harry E. Ellis*

BY  
*Philip A. Swell*  
ATTORNEY.

May 9, 1933.

H. E. ELLIS

1,908,590

APPARATUS FOR PRODUCING PULP WITHOUT HEAT

Filed Dec. 19, 1929

4 Sheets-Sheet 4

*Fig. 5.*

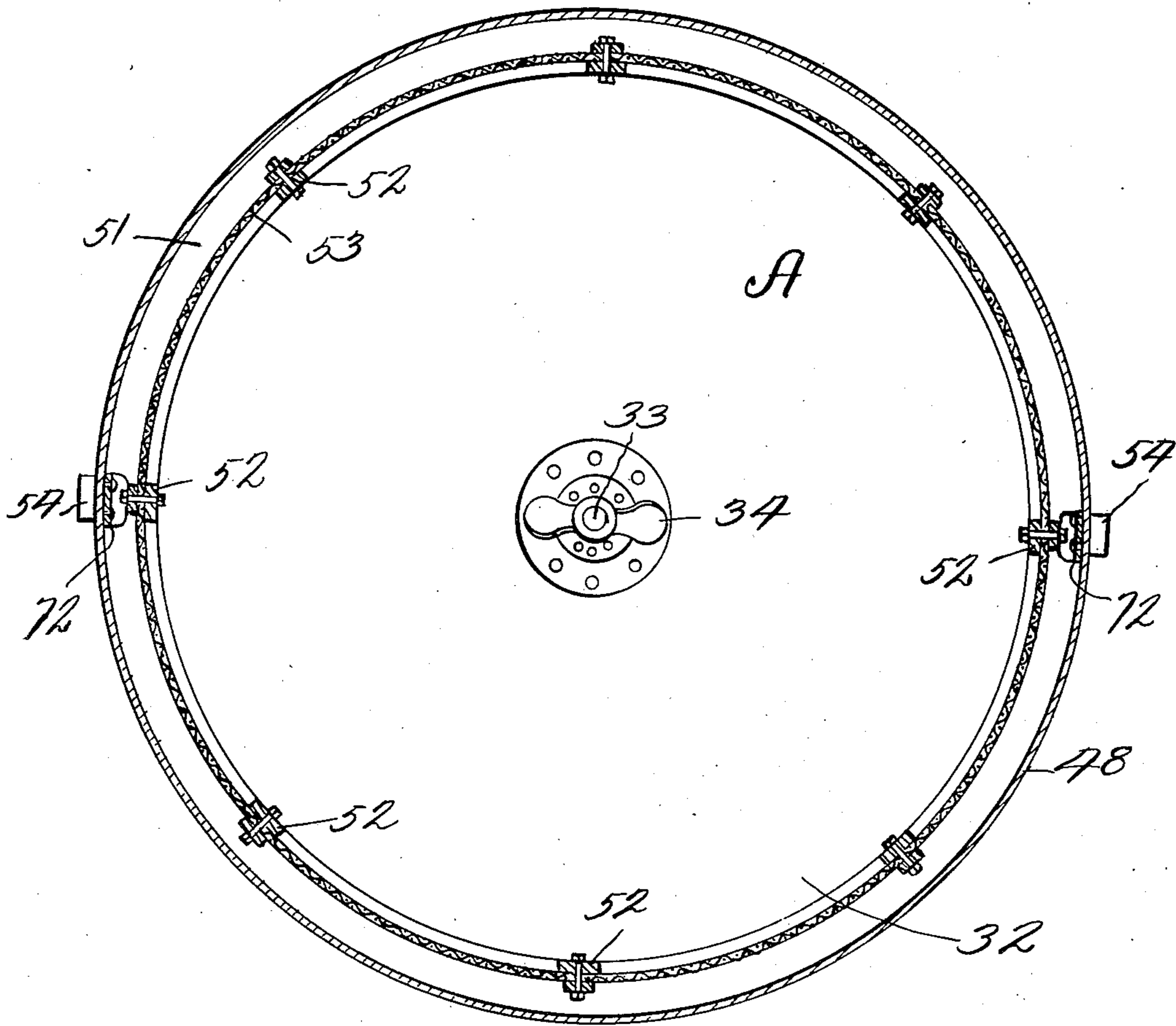

INVENTOR.  
*Harry E. Ellis*  
BY  
*Philip A. Ferrell*  
ATTORNEY.

# UNITED STATES PATENT OFFICE

HARRY E. ELLIS, OF JACKSONVILLE, FLORIDA

APPARATUS FOR PRODUCING PULP WITHOUT HEAT

Application filed December 19, 1929. Serial No. 415,268.

The invention relates to a chemical process and apparatus for the production of paper pulp from various grasses, such for instance as napier, papyrus, ramie, bamboo, spartina grass and others, which contain strong fibres, preferably have rapid growth and heavy yield per acre; preferably perennials.

A further object is to produce pulp for the paper and other industries by a chemical process, using plant material of a fibrous nature and without the use of heat.

A further object is to reduce the fibrous plant material to a bleach pulp by subjecting the same to a cold chemical action of caustic soda solution and chlorine alternately.

A further object is to provide a process of producing pulp from vegetable fibrous material comprising subjecting a mass of material alternately to the action of different chemicals, preferably caustic soda solution and chlorine, varying the time of each application according to the material and finally compressing the pulp so formed.

A further object is to provide a process for producing pulp comprising first producing in an electrolytic device caustic soda solution and chlorine, next alternately treating fibrous vegetable material with said caustic soda solution and chlorine for predetermined periods and finally compressing the material so treated and separating the solution therefrom.

A further object is to provide a process for producing pulp comprising first electrolytically producing caustic soda solution and chlorine alternately applying said solution of caustic soda and chlorine for predetermined periods to the body of fibrous vegetable material, next floating the disintegrated pulp from the top of the body of fibrous material, next screening the material so floated, then compressing the screened material separating the salt solution therefrom, delivering the separated salt solution to the electrolytic producing point and adding to said salt solution in its course to the electrolytic producing point.

A further object is to provide a process for producing pulp by the use of a caustic soda solution and chlorine alternately applied to

a fibrous body for predetermined periods, next separating the chemical solution from the pulp and finally recirculating the separated chemical solution. Also to supply to said recirculating chemical solution fresh material in predetermined quantity.

A further object is to provide a pulp producing apparatus comprising independent receptacles for the reception of shredded vegetable fibrous material, an electrolytic device, means for supplying a brine solution to the electrolytic device, means for conducting caustic soda solution and chlorine from said electrolytic device to the receptacles, means whereby said solutions may be alternately discharged into said receptacles.

A further object is to provide a pulp producing apparatus comprising tanks independent of each other for the reception of vegetable fibrous material, an electrolytic device for producing a caustic soda solution and chlorine, valve controlled pipe means for delivering said caustic soda solution and chlorine alternately to the tanks for predetermined periods, a pulp compressor, means for conveying the treated pulp from the tanks to the compressor, means for conveying the solution separated from the pulp to the electrolytic device for recirculation to the apparatus and means for replenishing the solution during its recirculation with the brine solution.

A further object is to provide means for supplying liquid, preferably water, to the pulp discharged from the compressor, thereby allowing the pulp to be pumped to a point of storage, for instance a stuff chest adjacent the beater.

A further object is to provide rotatable agitators in the tanks for agitating the material during the chemical treatment for disintegrating and bleaching and to provide the upper portions of the tanks with screened chambers into which the treated pulp is floated and means for conveying the treated pulp with a caustic soda solution therein from the chambers to a screening device, preferably interposed in the apparatus for screening the treated material before it is delivered to the

pulp compressor for separating the chemical solution therefrom.

A further object is to form the tanks conically shaped with their apexes downwardly disposed and the tanks lined with plastic material, for instance concrete and to place the rotatable agitators in the lower ends of the tanks.

A further object is to provide the upper ends of the tanks with endless chambers extending around the same and having their inner walls formed from screens and valve controlled outlets for the chambers.

With the above and other objects in view the invention resides in the combination and arrangement of parts as hereinafter set forth, shown in the drawings, described and claimed, it being understood that changes in the precise embodiment of the invention may be made within the scope of what is claimed without departing from the spirit of the invention.

In the drawings:

Figure 1 is a top plan view of the device.

Figure 2 is a side elevation of the device.

Figure 3 is a vertical longitudinal sectional view through one of the tanks.

Figure 4 is a detail perspective view of a portion of one of the tank troughs, showing the gate valve carried thereby.

Figure 5 is a horizontal sectional view through the upper end of one of the tank troughs.

Figure 6 is a horizontal sectional view through the control valves for controlling the flow of chlorine and caustic soda solution to the tanks.

Referring to the drawings, the numeral 1 designates a plurality of electrolytic cells disposed in casings 2 and connected together in any suitable manner, and which cells are supplied with electric energy from any suitable source. The electrolytic cell casings 2 are connected together by a brine pipe 4, and which pipe conducts brine to the various cell casings 2 from the brine supply tank 5 when the valve 5a is opened. The supply of brine within the supply tank 5 is replenished from time to time during the recirculation of the solution as hereinafter set forth from the brine mixing tank 6 through the pipe 7 when the valve 8 is opened. The addition of brine is for the purpose of maintaining the recirculating solution at the proper strength for obtaining maximum results. Disposed adjacent one side of the electrolytic cells is a pipe 9 having branch pipes 10 extending into the cell casings 2 for taking off the caustic soda solution through the pipe 9, and branch pipe 11 when the pump 12 is in operation which creates a suction, and which pump is of conventional construction, and discharges the caustic solution upwardly through the pipe 13, thence through the three way valve 14 to the discharge pipes 15 and 16, which dis-

charge pipes terminate above and discharge downwardly into the chemical mixing tanks A and B.

Disposed to the opposite side of the electrolytic casings 2 from the caustic soda pipe 9 is a pipe 17, through which chlorine generated by the cells passes after passing through the branch pipes 18, and the movement of the chlorine through pipes 17 and 18 is caused by the suction pump 19, which discharges the chlorine upwardly through the pipe 20 to the three way valve 21, and by means of the three way valve the chlorine can be directed through either of the branch pipes 22 and 23 to either tank A or B. By providing three way valves 14 and 21, it is obvious that when a batch of material is being treated in either of the tanks, it can be subjected alternately to the action of the caustic soda solution and chlorine, thereby disintegrating the fibres and breaking down the plant structure rapidly, and at the same time bleaching the material.

Pumps 12 and 19 are simultaneously operated by a driven shaft 24 which has driving connections 25 with a countershaft 26, and which countershaft is driven by a motor 27, which may be located in any convenient position, all of which structure is of a conventional form.

In operation shredded vegetable fibrous material is deposited into a hopper 28 from any suitable source, for instance from a shredding machine as set forth in patent issued to me #1,358,302 November 9, 1920, crusher and shredder, however applicant does not limit himself to this particular type of shredder. The hopper 28 is provided with downwardly extending pipes 29 terminating above the tanks A and B, and disposed in said discharge pipes 29 are control valves 30 adapted to be manipulated for discharging material into the tanks as desired.

The tanks A and B are similarly constructed therefore one will be described in detail, and the reference numerals will be applied to both. The tank A is preferably frusto conically shaped with its apex downwardly disposed and comprises a metallic shell 31 having a relatively thick lining 32 formed from plastic material, for instance concrete to resist the action of the chemicals used in reducing the material to pulp, and also forming a rough surface which will help to break up the fibre of the material. Rotatably mounted in the lower end of the tank is a vertically disposed shaft 33 having a bladed agitator 34 on the upper end thereof within the tank, and which agitator is continuously rotated during the pulp treating operation for thoroughly mixing the pulp and solution for disintegrating purposes, and in a manner whereby the broken up fibres will rise to the tops of the tanks. Shafts 33 are provided with bevelled gears

35, which mesh with bevelled gears 36 carried by shafts 37, and mounted on the shafts 37 are driven gears 38 which mesh with the drive pinions 39 carried by the motors 40, therefore it will be seen that the agitators will be driven at all times during the operation of the motors. The tank shells 31 are provided with downwardly extending supporting legs 41, preferably four in number, thereby rigidly supporting the tanks and the weights. Legs 41 are preferably provided with brace bars 42. It will be noted that the tanks A and B are for purposes of general arrangement disposed adjacent each other so that the various chemical pipe lines may be symmetrically arranged, and by the particular shape of the tanks, a great deal of the mechanism, for instance motors, may be disposed partially beneath the tanks.

Tank A at its upper end terminates in a horizontal flange 43, to which is secured by means of bolts 47 an annular member 48, which is right angularly shaped in vertical transverse cross section and has secured to its upper portion by means of an angle bar 49 and brace bars 50 which form an annular pulp and chemical receiving chamber 51. Connected to the inner sides of the members 48 and 50 are spaced vertically disposed bars 52, which form clamping means for the screen copper annular members 53, through the mesh of which the disintegrated and bleached pulp passes to the chambers 51. The level of pulp and chemical within the tank is preferably maintained about one half the elevation of the screen members 53, and which result is accomplished by manipulating the three way valve 14 and 19.

In the treatment of the pulp with both tanks full, the three way valve 14 is opened for allowing discharge of the caustic soda solution into both tanks, and after subjecting the pulp to this chemical action for the desired length of time to obtain the result, according to the nature of the fibrous material, valve 14 is closed and valve 21 opened, therefore it will be seen that chlorine is discharged into the tank, which will not only assist in the disintegrating operation, but will act as bleaching agent.

Connected to the pulp discharge troughs 51 at opposite sides thereof are discharge pipes 54 which lead to the intake pipe 55 of the screening machine 56, and which screening machine is driven by means of an electric motor 57 having a belt connection 58 with the pulley 59 of the screening machine. The pulp and the solution mixed therewith is discharged from the screening machine into a trough 60 which discharges into the trough 61.

Disposed beneath the discharge end of the trough 61 and preferably beneath a portion of the chemical tank A is a conventional form of screw press 62 and into which the pulp

and solution pass. The screw press 62 is operated by a conventional form of motor 63, and when in operation compresses the chemical saturated pulp, separating the liquid from the pulp and discharging the same through the discharge hopper 64 into the tank 65, and the substantially dry pulp into the stuff chest 66 for transfer to a conventional form of beater 67 through mechanism hereinafter set forth. It will be noted that the pulp has been disintegrated and the chemical squeezed therefrom into the tank 65, and as the chemical solution can be reused if again placed in the brine supply tank 5, therefore to accomplish this result, a suction pipe 68 carried by a centrifugal pump 69 is provided, and which suction pipe extends downwardly into tank 65. Pump 69 is driven by a conventional form of motor 70. Connected to the pump 69 is a discharge pipe 71, which discharge pipe leads to and discharges into the brine supply tank 5, and from which brine supply tank the solution is recirculated through the electrolytic casings 2 as above set forth by the pumps 12 and 19. The above operation continues with different batches of material in the tank.

Slidably mounted within the annular chambers 51 of the tanks are plate valves 72 controlled by handles 73, and by means of which valves the operator can discharge the contents from the annular chambers 51 as desired, and when the pulp is disintegrated and bleached. As the chemical solution recirculates additional brine solution may be supplied by opening the valve 8 controlling the flow from the brine mixing tank 6 to the brine supply tank 5.

As the pulp discharged into the stuff chest 66 from the screw press 62 is relatively dry, it is obvious to handle the same by pumping operation that liquid should be applied thereto. To accomplish this result the water supply pipe 74 is provided having a control valve 75, therefore it will be seen that the pulp can be reduced to a liquid form for pumping purposes, whereby it can be sucked through the intake pipe 76 to the pump 77, and which pump is operated by a motor 78. The wet pulp is discharged from the pump 77 through the discharge pipe 79 into the storage stuff chest 80, and from which stuff chest 80 the pulp is discharged for use as desired, into the beater and washer 67 through the pipe 81 when the valve 82 is open. The beater and washer is of conventional construction.

From the above it will be seen that a process and apparatus for the production of pulp from fibrous vegetable material by a cold chemical operation is provided, which allows the pulp to be alternately subjected to the action of caustic soda solution and chlorine and that two batches of material can be handled at one time, thereby materially increas-

ing the output of material, consequently reducing the cost of production. It will also be seen that the recirculating solution can be continuously used and means is provided for

5 supplying fresh brine solution to the recirculating solution for maintaining proper grade of material.

The chlorine combines with the caustic soda solution forming hypochlorite of sodium.

The invention having been set forth what is claimed as new and useful is:

1. A pulp producing apparatus comprising a brine supply tank, conduit means for discharging brine from said tank, a chemical tank, an electrolytic device for producing caustic soda solution and chlorine and into which the brine tank discharges, pump means whereby said caustic soda solution and chlorine may be alternately discharged into the chemical tank from the electrolytic device and conduit means whereby pulp within the chemical tank can be discharged therefrom.

2. A pulp producing apparatus comprising a fibrous material receiving tank, a brine supply tank, an electrolytic device for the production of caustic soda and chlorine, conduit means whereby brine from the brine tank may be supplied to the electrolytic device and pump means whereby the caustic soda solution and chlorine produced by the electrolytic device may be alternately discharged into the fibrous material receiving tank.

3. A pulp producing apparatus comprising a fibrous material receiving tank, a brine supply tank, an electrolytic device for the production of caustic soda and chlorine, means whereby brine from the brine tank may be supplied to the electrolytic device, pump means whereby the caustic soda and chlorine may be discharged into the fibrous material receiving tanks, valves whereby the caustic soda solution and chlorine may be discharged alternately into the fibrous material receiving tank and conduit whereby material within said tank may be discharged therefrom.

4. A pulp producing apparatus comprising a fibrous material receiving tank, a brine supply tank, an electrolytic device for the production of caustic soda and chlorine, means whereby brine from the brine supply tank may be discharged into the electrolytic device, means whereby caustic soda solution and chlorine from the electrolytic device may be discharged alternately into the fibrous material receiving tank, means whereby material within said tank may be discharged therefrom, means whereby chemical solutions within the pulp is expressed therefrom and means whereby said expressed chemical solution is discharged into the brine tank.

5. A pulp producing apparatus compris-

ing a fibrous material receiving tank, a brine supply tank, an electrolytic device for the production of caustic soda and chlorine, means whereby brine from the brine supply tank may be discharged into the electrolytic device, means whereby caustic soda solution and chlorine from the electrolytic device may be discharged alternately into the fibrous material receiving tank, means whereby material within said tank may be discharged therefrom, means whereby chemical solution within the pulp is expressed therefrom, means whereby said expressed chemical solution is discharged into the brine tank and means whereby fresh brine may be added to the solution in the brine tank as desired.

6. A pulp producing apparatus comprising separate fibrous material tanks, a brine supply tank, an electrolytic device for the production of caustic soda solution and chlorine, conduit means whereby brine from the brine tank may be discharged into the electrolytic device, valve controlled pump means whereby the caustic soda solution and chlorine may be alternately discharged into the fibrous material receiving tanks and conduit means whereby material within said tanks may be alternately discharged therefrom.

7. A pulp producing apparatus comprising separate fibrous material tanks, a brine supply tank, an electrolytic device for the production of caustic soda solution and chlorine, means whereby brine from the brine tank may be discharged into the electrolytic device, means whereby the caustic soda solution and chlorine may be alternately discharged into the fibrous material receiving tanks, means whereby pulp material within said tank may be discharged therefrom, a press for expressing the chemical solution from the pulp and means for discharging the expressed chemical solution into the brine tank.

8. A pulp producing apparatus comprising separate fibrous material tanks, a brine supply tank, an electrolytic device for the production of caustic soda solution and chlorine, means whereby brine from the brine tank may be discharged into the electrolytic device, means whereby caustic soda solution and chlorine may be alternately discharged into the fibrous material receiving tanks, means whereby pulp material within said tanks may be discharged therefrom, means for expressing chemical solution from the pulp, means for discharging the expressed chemical solution into the brine tank for recirculation, and means for supplying brine solution to the brine tank during the recirculation.

9. An apparatus for the production of pulp comprising a pulp receiving tank, means for discharging fibrous material into said tank, valve controlled pump means for alternately discharging different chemical



solutions into the tank, the upper end of said tank being provided with a pulp receiving chamber, the inner wall of said chamber being perforated for allowing passage of pulp from the tank to the chamber and conduit means for discharging the pulp from said chamber.

10. The combination with a pulp forming apparatus having separate chemical tanks for the reception of fibrous material, means for subjecting said fibrous material to a chemical treatment, of chambers carried by said tanks and into which pulp chemically formed passes, said chambers having perforated walls through which pulp passes to the chambers, a single pulp press and conduits whereby pulp from the chambers may be alternately discharged into the pulp press.

20 11. The combination with a pulp forming apparatus having separate chemical tanks for the reception of fibrous material, a pulp press, pump conduit means for subjecting said fibrous material to alternately different chemical treatment in the tanks, of chambers carried by said tanks and into which pulp chemically treated and formed passes, said chambers having walls provided with passes through which pulp passes to the chambers, valve control means within said tank chambers whereby pulp from the chambers may be discharged into the single pulp press, said press forming means for expressing chemicals from the pulp from both tanks and means for recirculating said chemicals.

35 12. The combination with a pulp forming apparatus having separate chemical tanks for the reception of fibrous vegetable material, means for subjecting said fibrous material alternately to the action of separate chemicals, of conduits for discharging the pulp alternately from the tanks, single press means for expressing the chemicals from the pulp so formed, conduits for recirculating the chemicals for independent alternate application to subsequent fibrous material in tank and branch pipe supply means for strengthening the chemical solution during their recirculation.

50 In testimony whereof he hereunto affixes his signature.

HARRY E. ELLIS.