

May 9, 1933.

B. W. SUNDE

1,907,461

FORCE MEASURING APPARATUS

Filed June 14, 1930

2 Sheets-Sheet 1

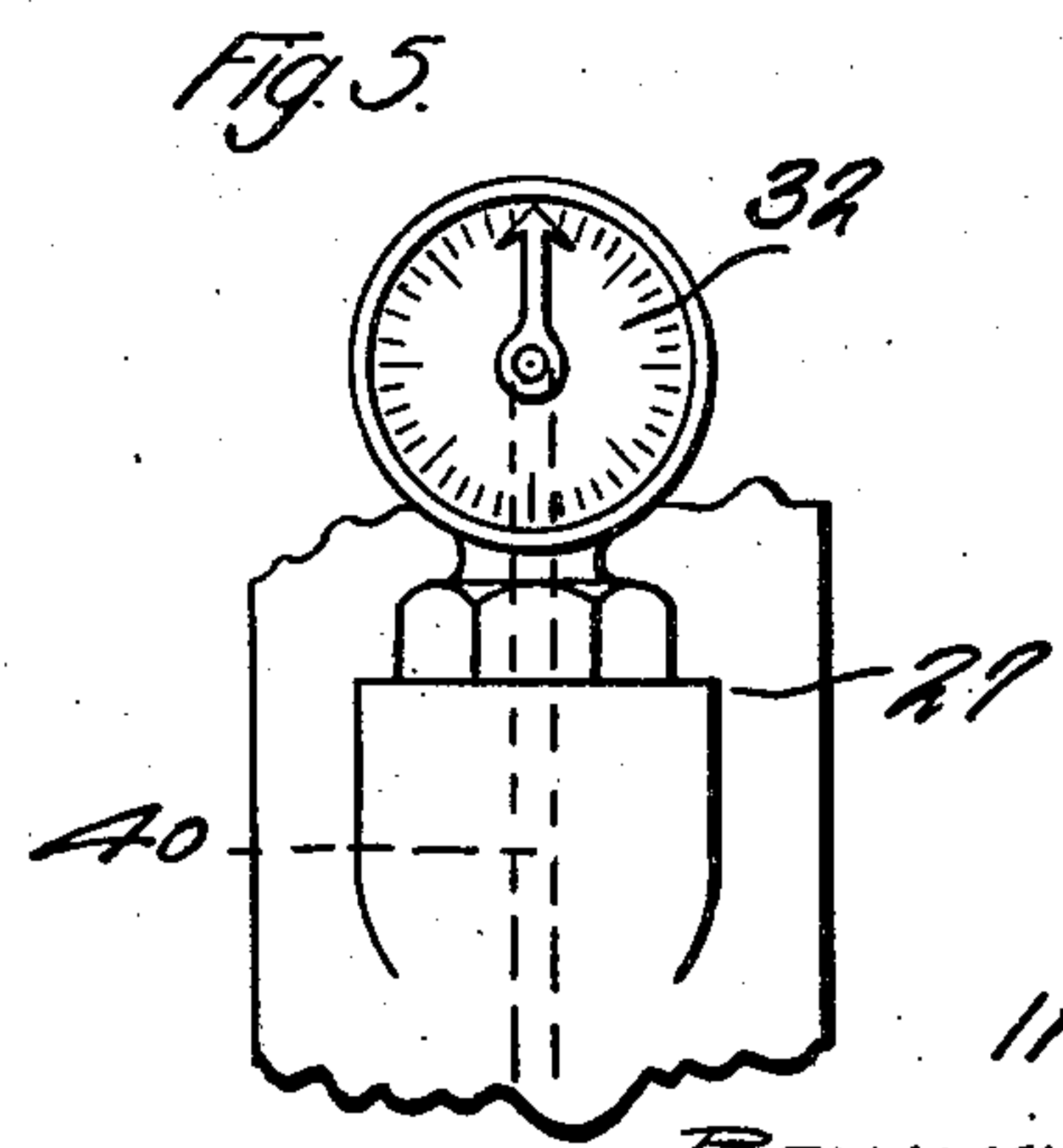
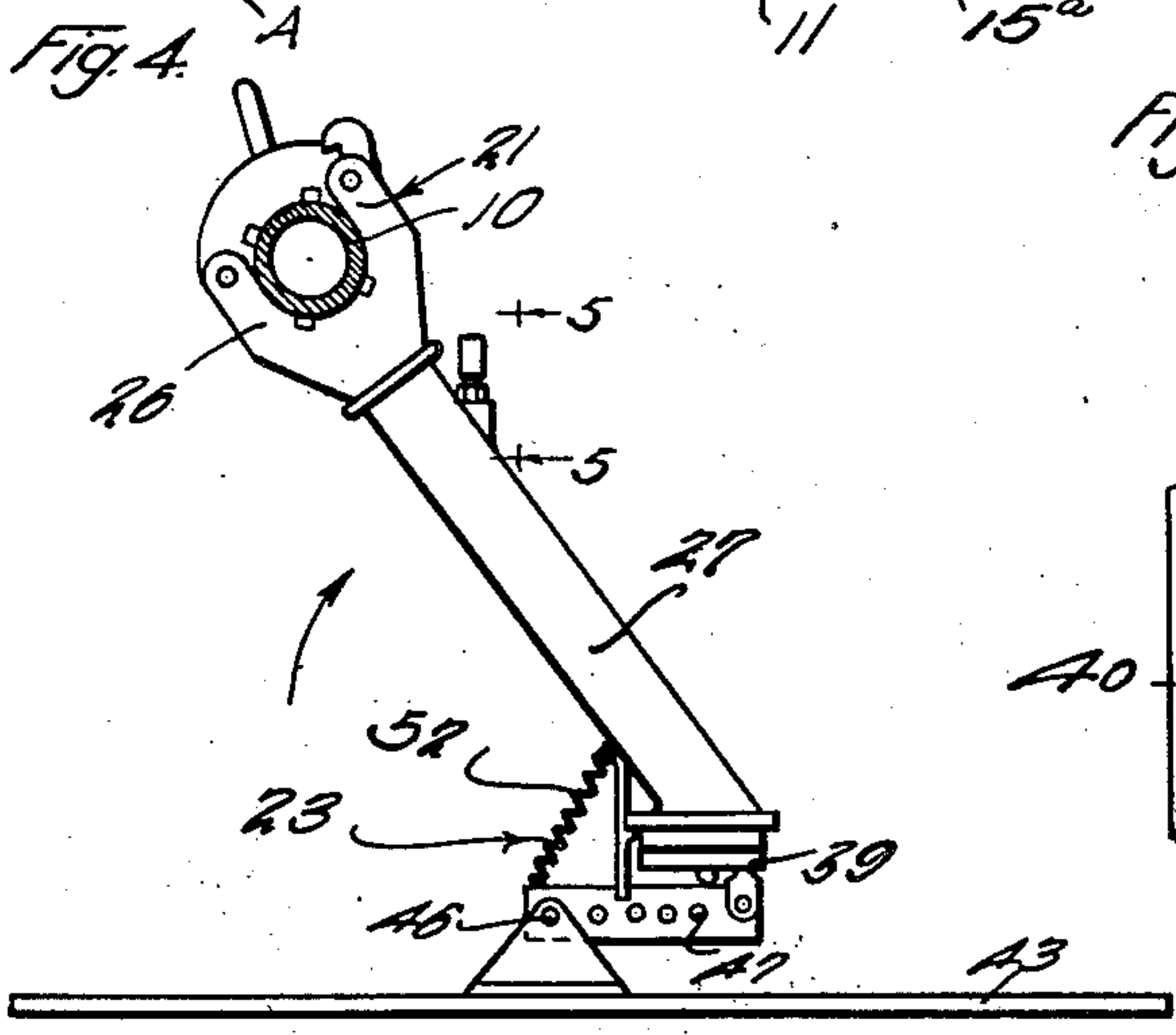
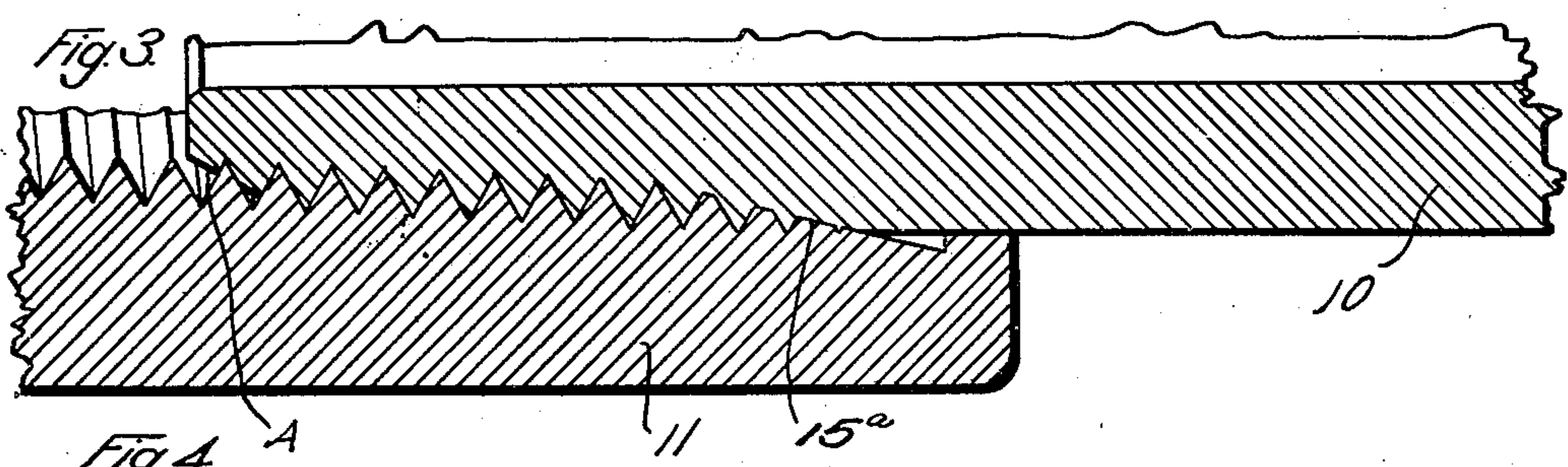
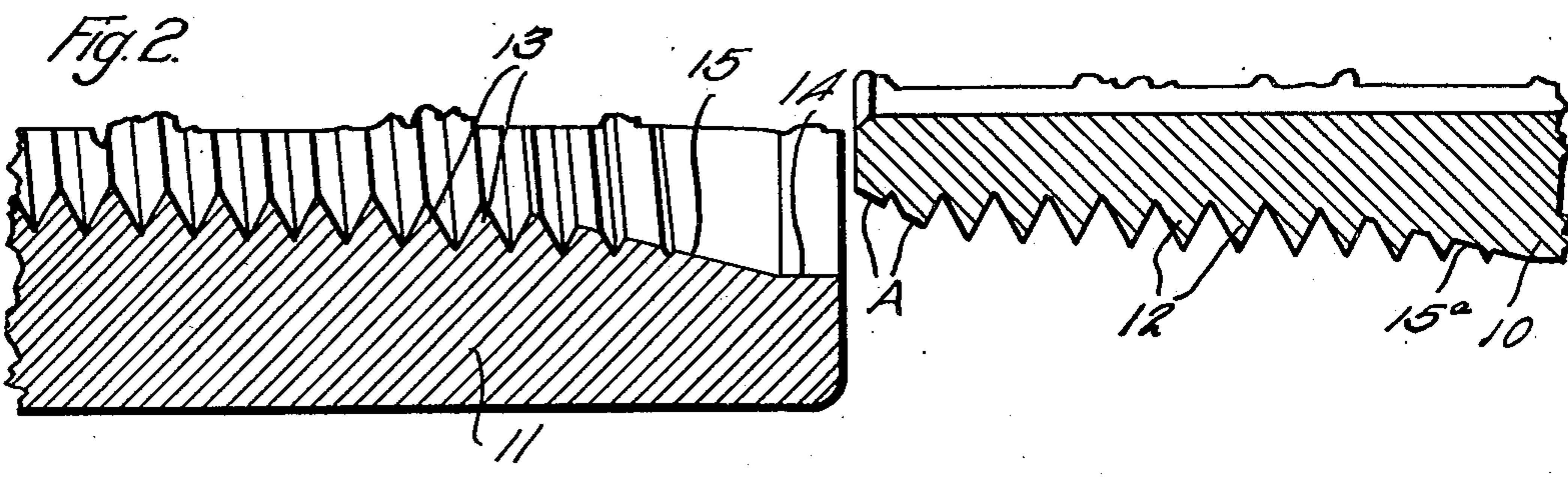
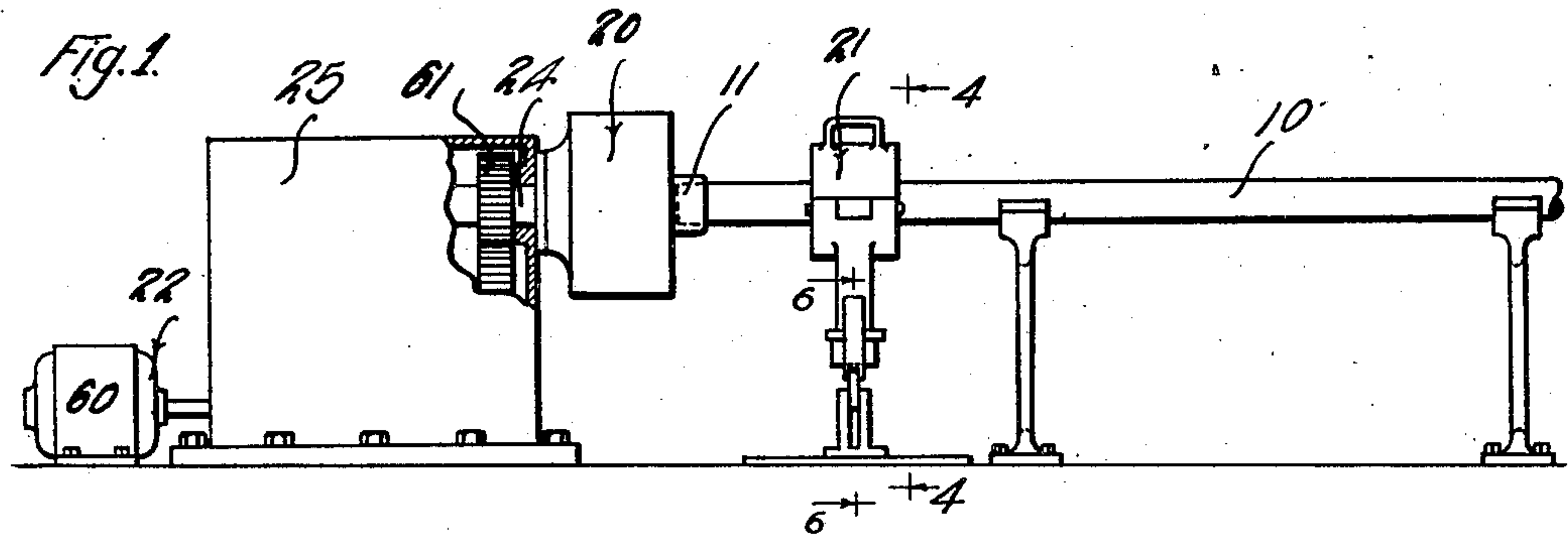

Inventor
BENJAMIN W. SUNDE
By *W. H. H. Spull*
His Attorney

May 9, 1933.

B. W. SUNDE

1,907,461

FORCE MEASURING APPARATUS

Filed June 14, 1930

2 Sheets-Sheet 2

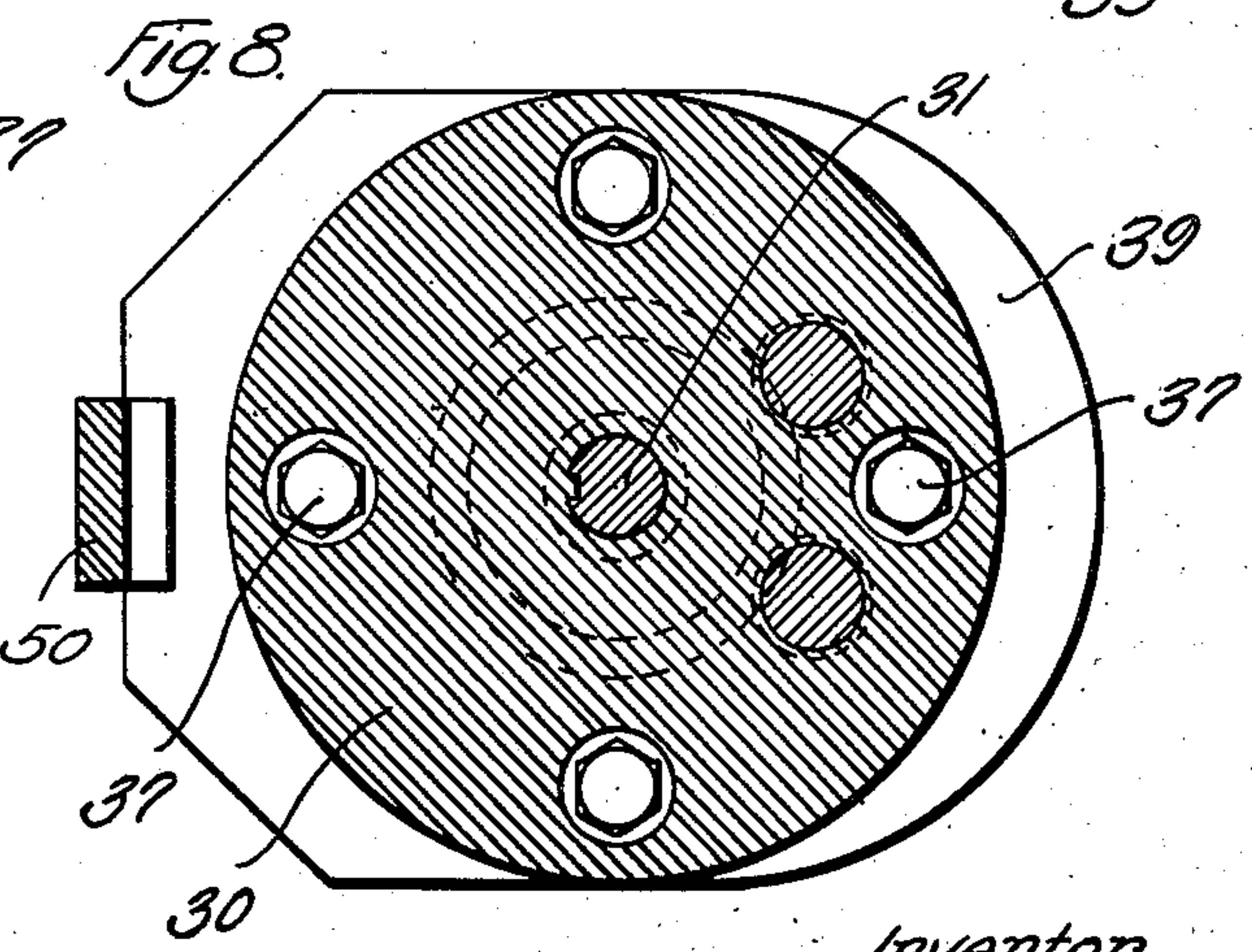
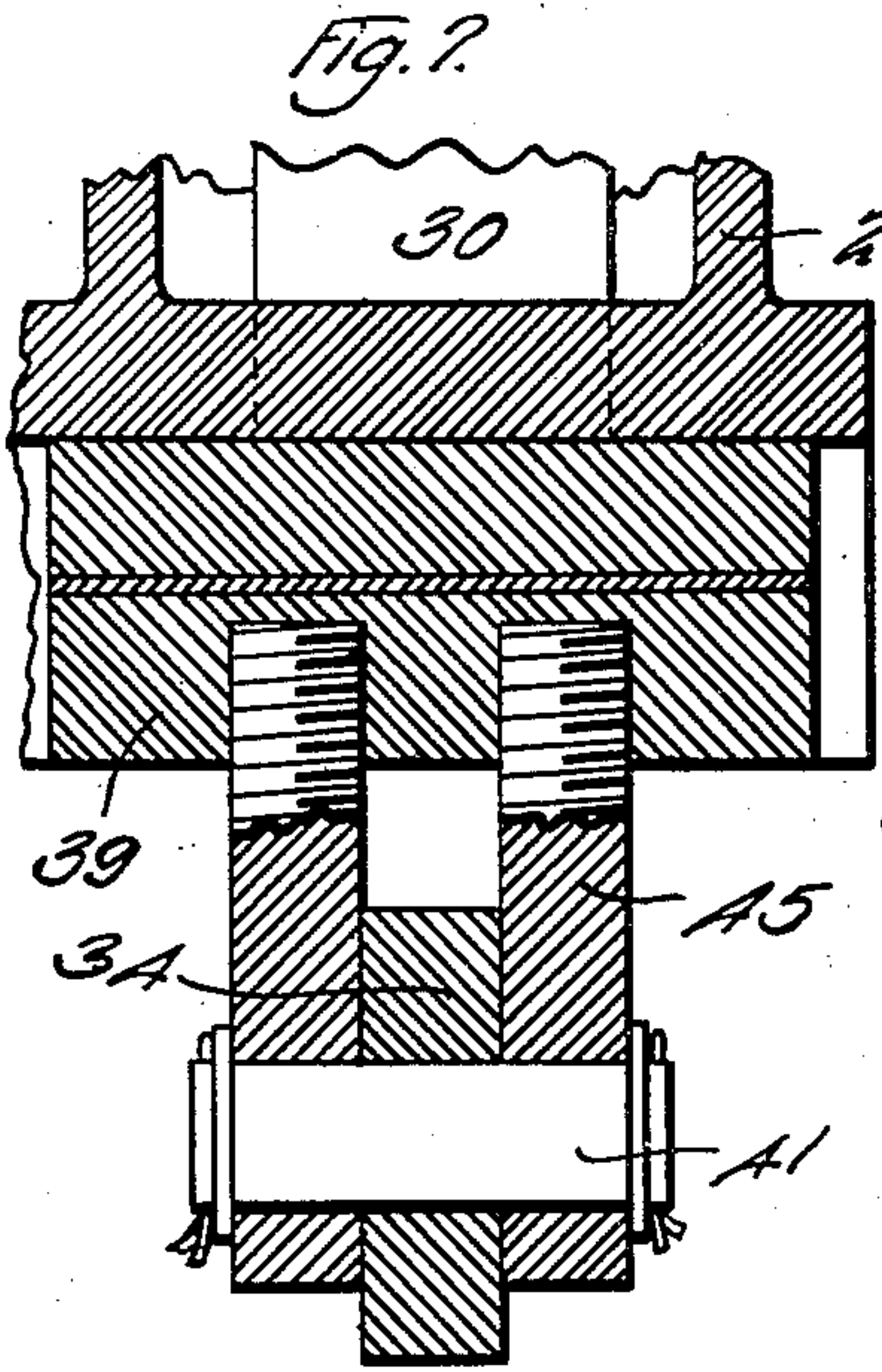
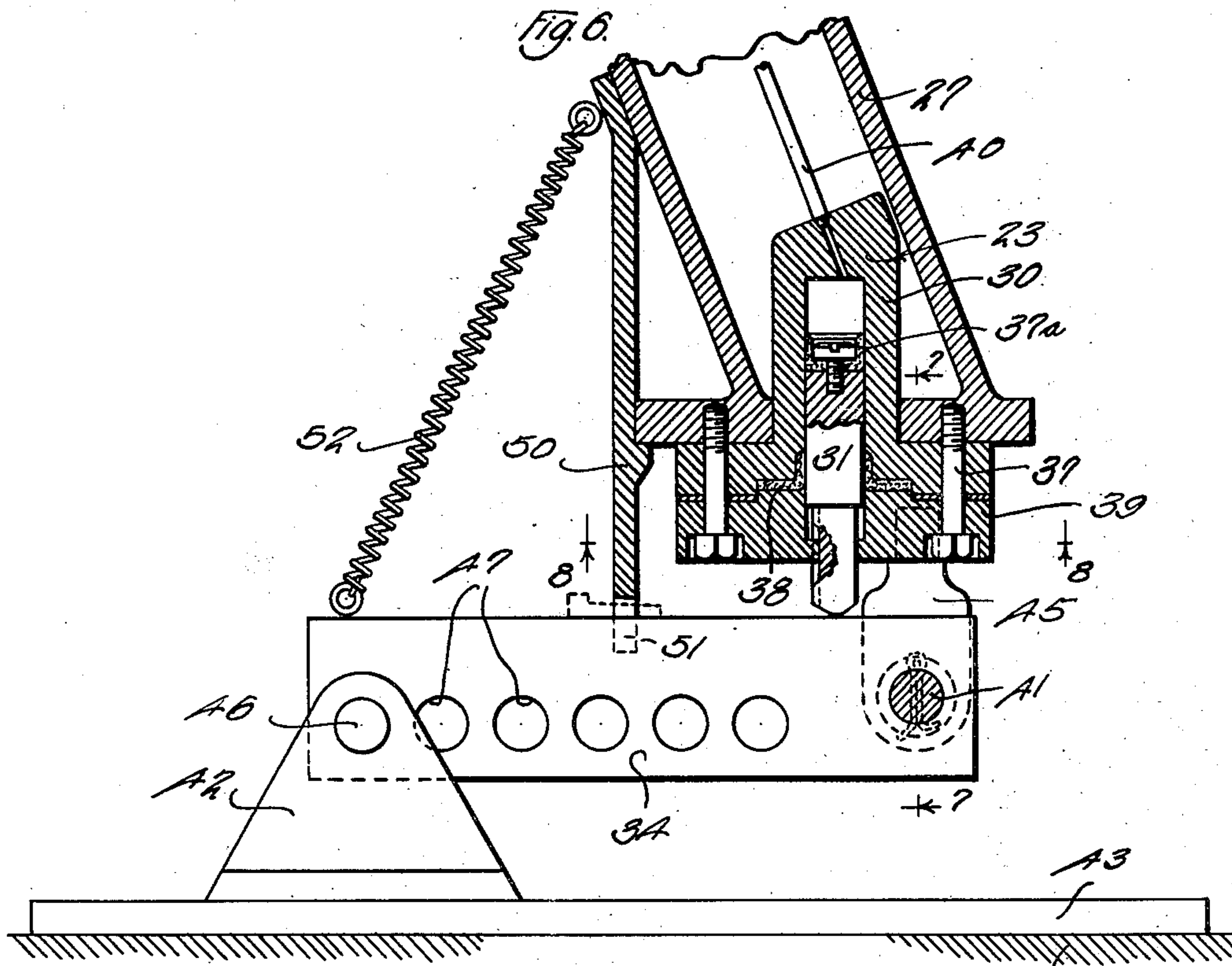

Inventor
BENJAMIN W. SUNDE
By *W. H. H. H. H. H.*
His Attorney

UNITED STATES PATENT OFFICE

BENJAMIN W. SUNDE, OF LONG BEACH, CALIFORNIA, ASSIGNOR TO BLACKWELL & SUNDE, INCORPORATED, OF LONG BEACH, CALIFORNIA, A CORPORATION OF CALIFORNIA

FORCE MEASURING APPARATUS

Application filed June 14, 1930. Serial No. 461,197.

This invention has to do with apparatus for connecting threaded parts, and it is a general object of the invention to provide an efficient, practical, and dependable apparatus particularly suited for connecting parts of a well drilling string, or the like.

In drilling wells with the rotary method the drill bit is carried at the lower end of a string of pipe known as "drill pipe". It is customary to form a string of drill pipe by connecting two lengths of pipe by means of an ordinary coupling to form what is known as a "double" and then join two or three doubles by means of tool joints to form a "stand". In the course of normal operation the drilling string is connected and broken only at or by means of the tool joints, the threaded connections directly with the pipe being left undisturbed. The threads of the tool joints, that is, the threads by which the parts of the tool joints are connected, are made heavy and coarse so that they can be operated many times without appreciable wear and are easily handled in the course of making and breaking the joints. The threads provided on the pipe sections and on the couplings and the parts of the tool joints that engage the pipe sections are the type of thread ordinarily employed on pipes and therefore will not stand a great deal of operation and are more or less difficult to start. In preparing a string of drill pipe for use effort is made to apply the couplings to the pipe sections and the tool joint sections to the pipe sections so that the threads are fully engaged and are not over strained. By reason of the nature of pipe threads, great difficulty is experienced in making these connections properly as such a connection tends to be loose and subject to creeping unless the threads are fully engaged, while the threads are usually damaged and materially weakened upon the connection being forced beyond the point where the threads are fully engaged. It has been customary to depend upon the skill of the workmen to determine when the connections are properly made, and as a result there is not uniformity in the connections throughout a drilling string and it not infrequently hap-

pens that the joints are weakened before the string is ever used.

It is an object of this invention to provide an apparatus whereby threaded parts, such, for example, as I have referred to above, may be connected properly and tightly without ever straining or in any way weakening the threads.

The various objects and features of my invention will be best and more fully understood from the following detailed description of a typical form and application of the invention, throughout which description reference is had to the accompanying drawings, in which:

Fig. 1 is a side elevation of the apparatus embodying the invention showing it in operating position, certain parts being broken away to show in section. Fig. 2 is an enlarged detailed sectional view of two threaded parts to be connected by the present invention showing the parts disengaged or separated. Fig. 3 is a view similar to Fig. 2 showing the parts engaged or completely screwed together. Fig. 4 is an enlarged detailed sectional view taken as indicated by line 4—4 on Fig. 1. Fig. 5 is an enlarged view taken as indicated by line 5—5 on Fig. 4. Fig. 6 is an enlarged detailed sectional view taken substantially as indicated by line 6—6 on Fig. 1. Fig. 7 is an enlarged view taken as indicated by line 7—7 on Fig. 6, and Fig. 8 is an enlarged view taken as indicated by line 8—8 on Fig. 6.

The present invention is particularly suited for application to the parts of a drilling string suitable for use in the rotary method of well drilling, and therefore I will proceed with a detailed description of a typical form and application of the invention and will throughout such description make reference to the connecting of a pipe section and a coupling or tool joint section.

It is believed that the significance of the present invention will be more readily appreciated if consideration is first given to the parts of a drilling string that are to be connected. In the drawings the numeral 10 designates a section of pipe, and the numeral 11 designates a coupling or tool joint section to

be threaded to the pipe. The end portion of the pipe 10 is externally threaded, the threads 12 being V-threads and tapered in accordance with the practice followed in pipe threads.

5 The first few threads on the pipe have their tops beveled away as shown at A, while the last few threads, or the innermost threads, are not cut to full depth but are cut to leave a beveled or inclined shoulder 15^a. The
10 threads 13 cut in the section 11 are shaped and tapered to correspond generally to the threads 12 of the pipe. In accordance with the practice followed in parts of a drilling string, a short straight counterbore 14 is provided at
15 the entrance to the section 11 or in the end of the section opening, and the tops of the first threads are cut off or away to form a beveled or inclined shoulder 15 converging inwardly from the counterbore. The parts are related
20 and proportioned so that the shoulder 15^a of the pipe engages the inclined shoulder 15 as the joint becomes tight or completely made up. When the shoulder 15^a of the pipe en-
25 gages the shoulder 15, further engagement of the parts is stopped unless the parts are forced, putting the threads under excessive strain.

In accordance with my invention I operate
30 two threaded parts together, say, for instance, a pipe section and a section of a tool joint and measure the force with which the parts are put together, observing the variation in force required to put the parts together as
35 the joint tightens and observing the sudden increase in force that develops the moment the thread 12 of the pipe engages the shoulder 15 of the coupling, and stopping operation of the engagement at the time that
40 the force increases due to engagement of the shoulder 15^a with the shoulder 15.

In practice I may carry out the invention in various ways and with various apparatus. In the following description I set forth a
45 typical preferred form of apparatus for carrying out the invention, it being understood that its broader principles are not to be construed as limited to this particular apparatus.

50 The apparatus provided by the invention includes, generally, two gripping devices 20 and 21 for engaging the threaded parts to be connected, means 22 for operating one of the devices to turn it relative to the other,
55 and means 23 for indicating the force with which the gripping devices are operated relative to each other.

In the drawings I have shown the gripping device 20 in the form of a chuck designed to
60 firmly grip one of the parts, say, for instance, a tool joint section 11, and I have shown the gripping device 21 in the form of a wrench or tongs for engaging the other part, in the case illustrated the pipe 10.

65 The chuck 20 is shown carried by a spindle 24 mounted in a suitable frame or housing 25.

The chuck may be of any suitable design or construction. For instance, it may be a chuck such as I have set forth and claimed in my co-pending application entitled Chuck, filed
70 January 14, 1929, Serial Number 332,488.

In practice it is convenient to make the gripping device 21 in the nature of tongs. The tongs illustrated includes a head 26 to en-
75 gage around and grip a pipe 10, and a handle 27 on the tongs. In practice I may use any suitable form or type of tongs. For instance, I may use an ordinary mechanical type of tongs or I may use a tongs such as I have set forth and claimed in my co-pending applica-
80 tion entitled Tongs, filed Feb. 17, 1930, Serial Number 429,052.

The means for operating one of the grip-
85 ping devices relative to the other is arranged to operate the chuck 20 through the spindle 24. In the drawings I have illustrated this means as including a motor 60 and a gear drive 61 between the motor and the spindle. The drive, which is within the housing 25,
90 is such as to effect a substantial speed reduction between the motor and the spindle, thus causing the chuck to be turned with great force.

The means 23 provided for indicating the force with which the gripping devices are operated relative to each other is arranged in
95 connection with one of the gripping devices, preferably in connection with the tongs 21. The indicating means when arranged in connection with the tongs 21 preferably oper-
100 ates to indicate the pressure or force required to hold the handle of the tongs against turning. The arrangement illustrated includes a cylinder 30 carried at the outer end portion of the handle 27 of the tongs, a ram 31 carried in the cylinder to be operated in the cylinder as force is applied tending to turn the
105 tongs, and a pressure gauge 32 connected with the cylinder to indicate the pressure exerted on fluid in the cylinder due to operation of the plunger in the cylinder. In the preferred construction a lever 34 is connected between the handle and a stationary support 35 to operate the ram 31 instead of allowing the ram to directly engage the support.

The cylinder 30 is fixed to the outer end
110 portion of the tongs handle 27. For instance, it may be secured to the handle through screws 37. The ram 31 slidably fits the bore of the cylinder and is provided with pack-
115 ing 37^a for making a tight connection with the cylinder. Further, in practice, packing 38 is carried by the cylinder to pack around the plunger, thus providing double packing
120 means between the plunger and cylinder. The packing 38 may be held in place by a plate 39 applied to the end of the cylinder and held in place by the screws 37. In the preferred arrangement the ram 31 projects
125 from the cylinder and through the plate 39

and is engaged by the plate so that it is prevented from turning or rotating. The ram 31 may be held against rotation in any suitable manner, for example by a key connection with the plate 39 as illustrated in Fig. 6 of the drawings.

The gauge 32 may be any suitable type of fluid pressure gauge located at a suitable part of the apparatus and connected with the cylinder 30 as by a fluid conduit 40.

The lever 34, which is interposed between the ram 31 and the stationary support 35, has one end pivotally connected with the handle 27 by a pivot pin 41 and the other or outer end pivotally connected with a shoe 42 which slidably engages a bearing plate 43 arranged on the support 35. In the construction shown the pin 41 is carried by brackets 45 projecting downwardly from the plate 39. The lever 34 is held by the pin 41 so that it extends under the projecting end of the ram 31. A pivot pin 46 connects the outer end of the lever 34 with the shoe 42. In practice a plurality of openings or bores 47 may be provided in the outer portion of the lever 34 so that the shoe may be connected at various points along the lever. By connecting the shoe at various points along the lever the leverage between the ram 31 and support 35 may be varied.

A guide 50 projects downwardly from the handle and has spaced parts 51 at its lower end extending on either side of the lever 34 to hold the lever against lateral displacement. In practice a wedge or other object such as is indicated in Fig. 6 may be placed between the guide 50 and the lever when it is desired to render the indicating means inoperative.

A spring 52 is connected under tension between the outer portion of the lever 34 and the handles 27 so that it normally holds the outer end of the lever up, keeping the mechanism just described in operating position under a predetermined pressure.

In operating the apparatus provided by the invention the parts to be connected, for instance, the pipe section 10 and section 11, are arranged in the gripping devices 20 and 21 as shown in Fig. 1 of the drawings. The motor 60 is put in operation so that the chuck 20 is operated through the drive 61 and the spindle 24. The rotation of the chuck causes the tool joint section 11 held by it to rotate relative to the pipe 10 held by the tongs 21. This rotation causes the threads of the parts 10 and 11 to engage and screw together. As the threads screw together the force with which the parts are being connected is indicated by the gauge 32 in that the handle 27 of the tongs tends to turn in the direction indicated by the arrow in Fig. 4, thus causing the lever 34 to act on the ram 31, putting fluid in the cylinder 30 under pressure, which pressure is indicated by the gauge. The

force required to screw the parts 10 and 11 together will not be excessive until the shoulder 15^a reaches the shoulder 15. When this occurs there is a marked increase in pressure which is immediately reflected in the gauge 32. Upon the pressure increasing sharply and before it reaches an excessive amount, the operation is discontinued. By thus screwing the parts 10 and 11 together, a fully engaged joint is assured without danger of over straining it in a manner to weaken or injure the threads. In the case of screwing an ordinary coupling on a pipe, the pressure or force will increase gradually until the pressure reaches a point sufficient to cause full seating of the threads whereupon the operation is stopped. The force required to properly seat the threads may be determined by experiment.

Having described only a typical, preferred form of my invention, I do not wish to limit myself to the specific details set forth, but wish to reserve to myself any changes or variations that may appear to those skilled in the art or fall within the scope of the following claims.

Having described my invention, I claim:

1. In combination tongs for gripping pipes adapted to be held against rotation, and pressure indicating means for indicating the force tending to turn the tongs, the pressure indicating means including, a cylinder carried by the handle of the tongs, a ram operable in the cylinder, a lever pivotally connected with the handle and engaging a stationary support, the lever operatively engaging the ram whereby the ram is operated in the cylinder upon movement of the tongs handle toward said support, and a pressure gauge in connection with the cylinder.

2. In combination tongs for gripping pipe to be turned and adapted to be held against rotation, and pressure indicating means for indicating the force tending to turn the tongs, the pressure indicating means including, a cylinder carried by the handle of the tongs, a ram operable in the cylinder, a lever pivotally connected with the outer end of the handle and engaging the ram, a shoe on the lever engaging a stationary support, and a pressure gauge in connection with the cylinder.

3. Apparatus of the character described, including tongs for gripping an object to be turned, the tongs being adapted to be held against rotation, and means for indicating the pressure tending to turn the tongs including a lever pivoted to the outer end of the handle of the tongs, a cylinder in the handle of the tongs, a ram in the cylinder and operatively engaged by the lever, a pressure gauge in connection with the cylinder, a shoe pivoted to an end of the lever and adapted to engage a stationary support, and a

spring connected between the handle and lever for maintaining the ram and lever in cooperative engagement.

In witness that I claim the foregoing I have hereunto subscribed my name this 23rd day of May 1930.

BENJAMIN W. SUNDE.

10

15

20

25

30

35

40

45

50

55

60

65