

May 3, 1932.

T. E. MURRAY

1,856,109

ELECTRIC CONDUCTOR

Filed Feb. 6, 1924

2 Sheets-Sheet 1

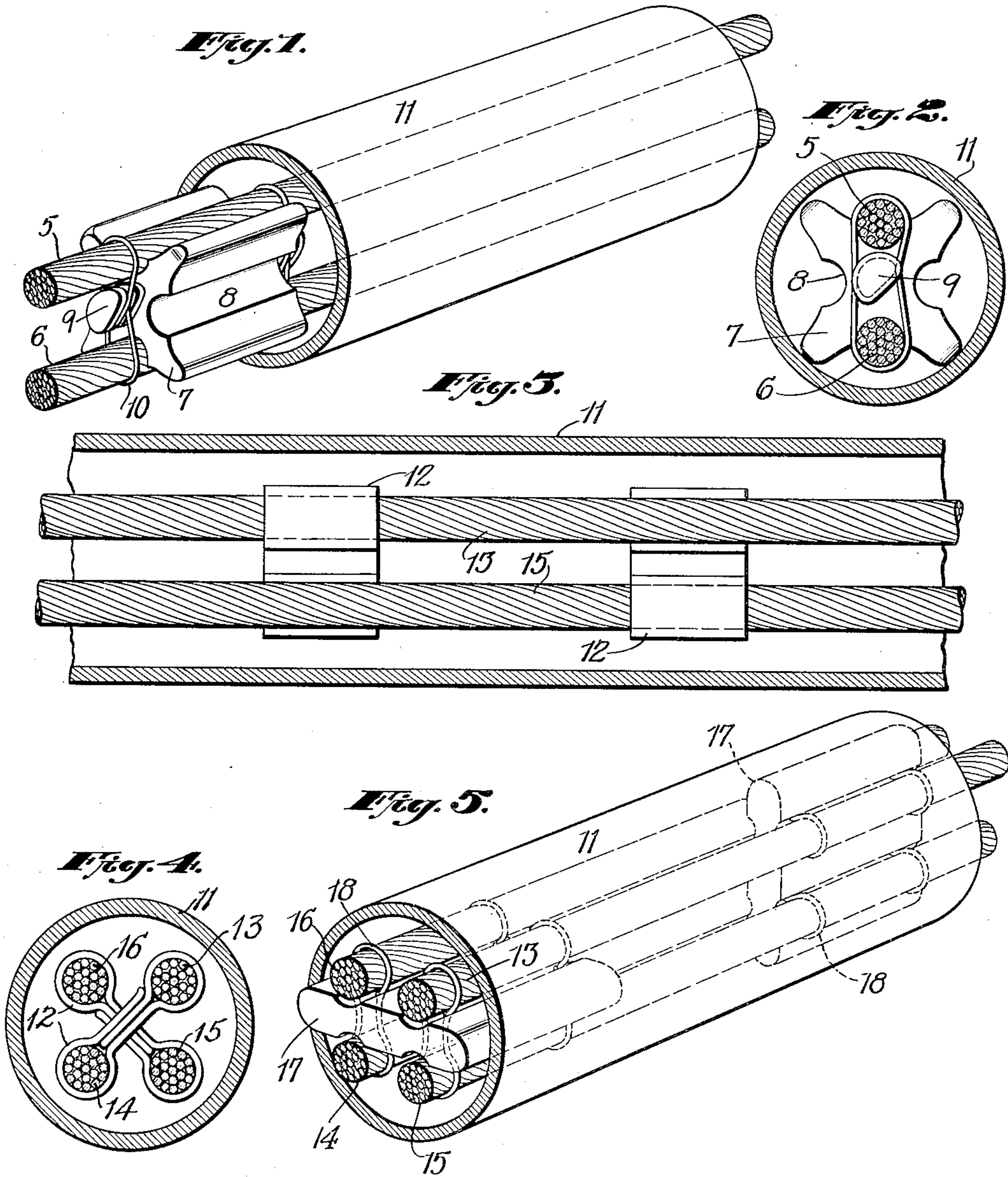

Inventor
THOMAS E. MURRAY.
By His Attorney
N. Anthony Reina

May 3, 1932.

T. E. MURRAY

1,856,109

ELECTRIC CONDUCTOR

Filed Feb. 6, 1924

2 Sheets-Sheet 2

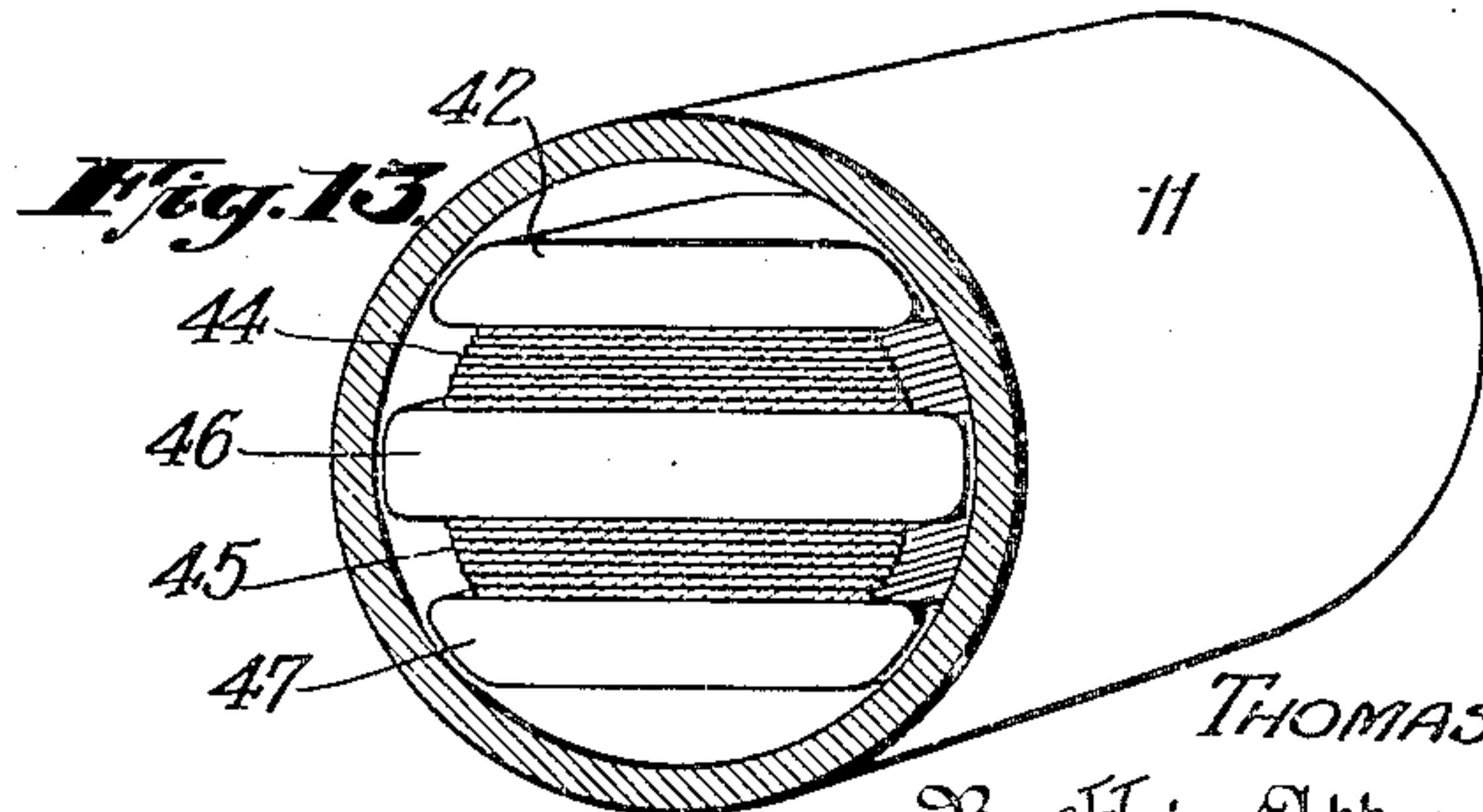
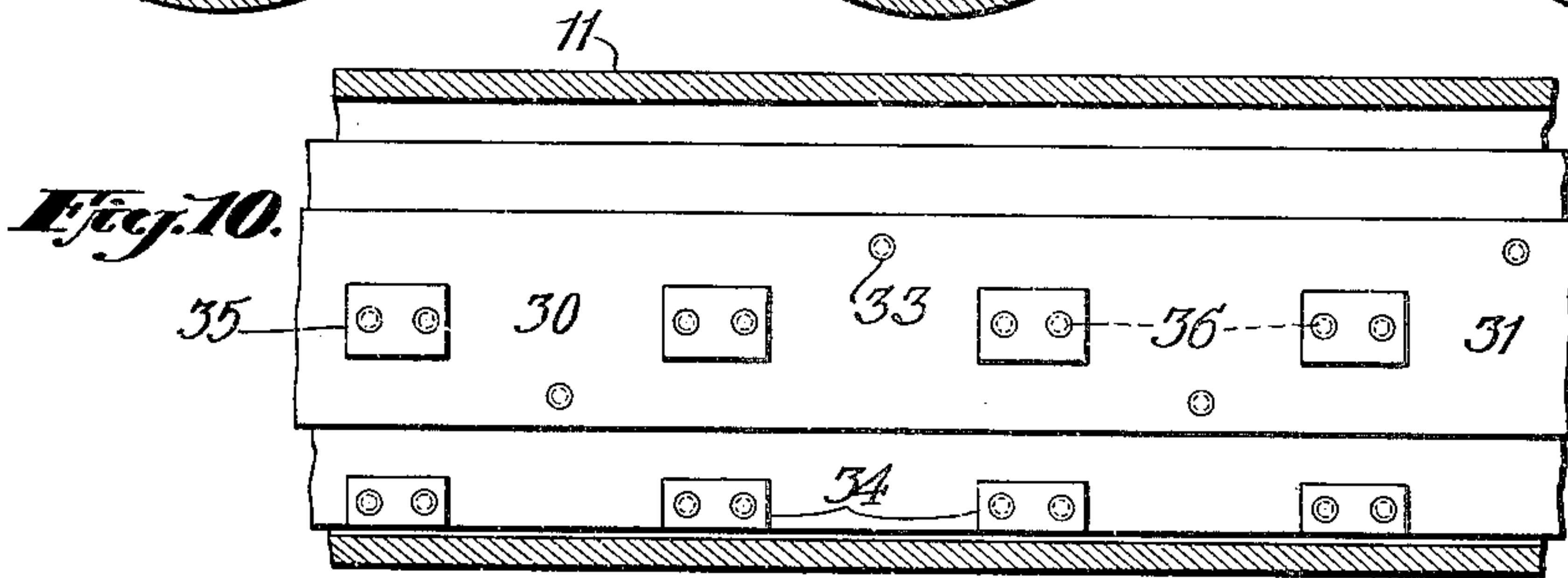
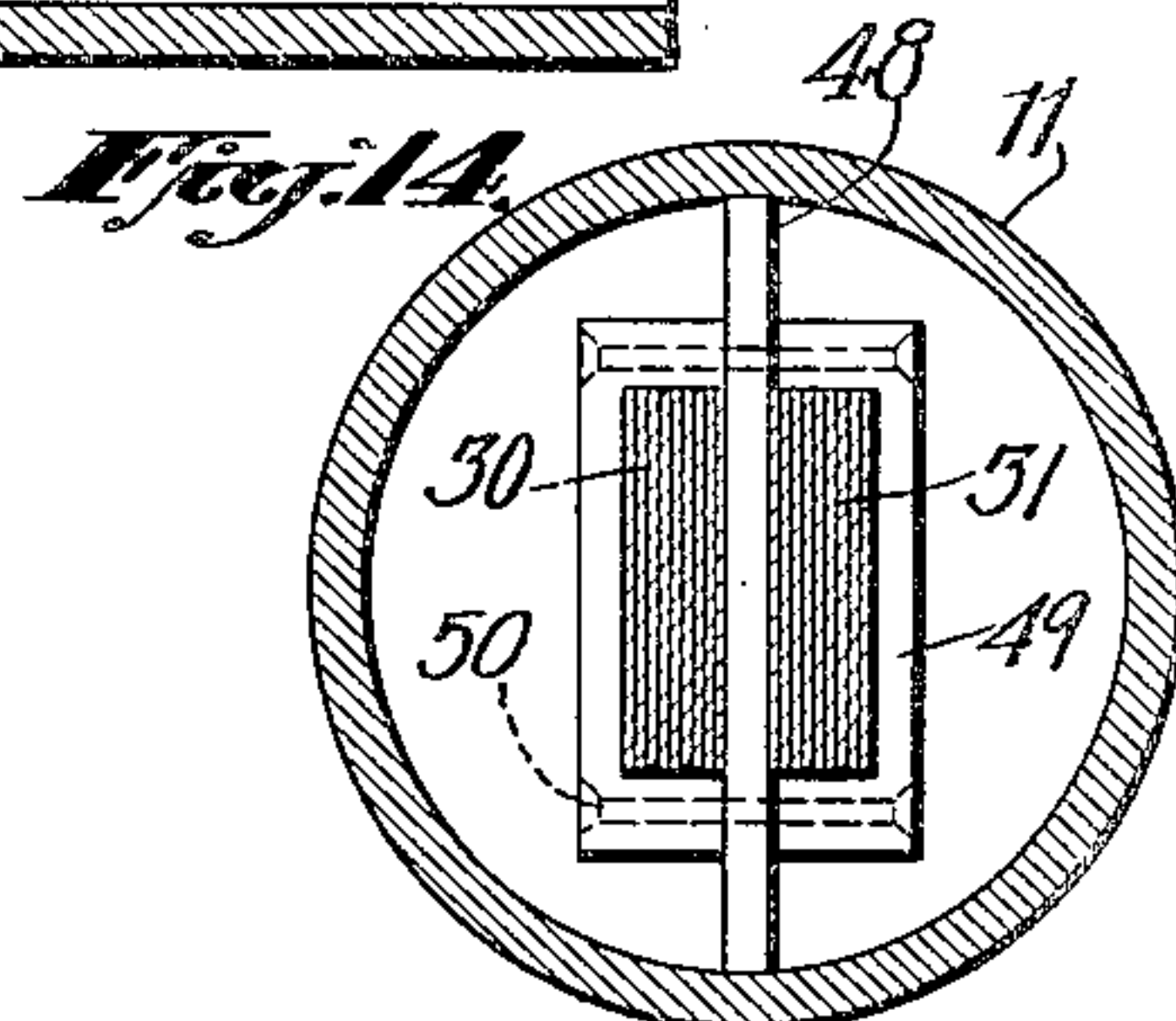
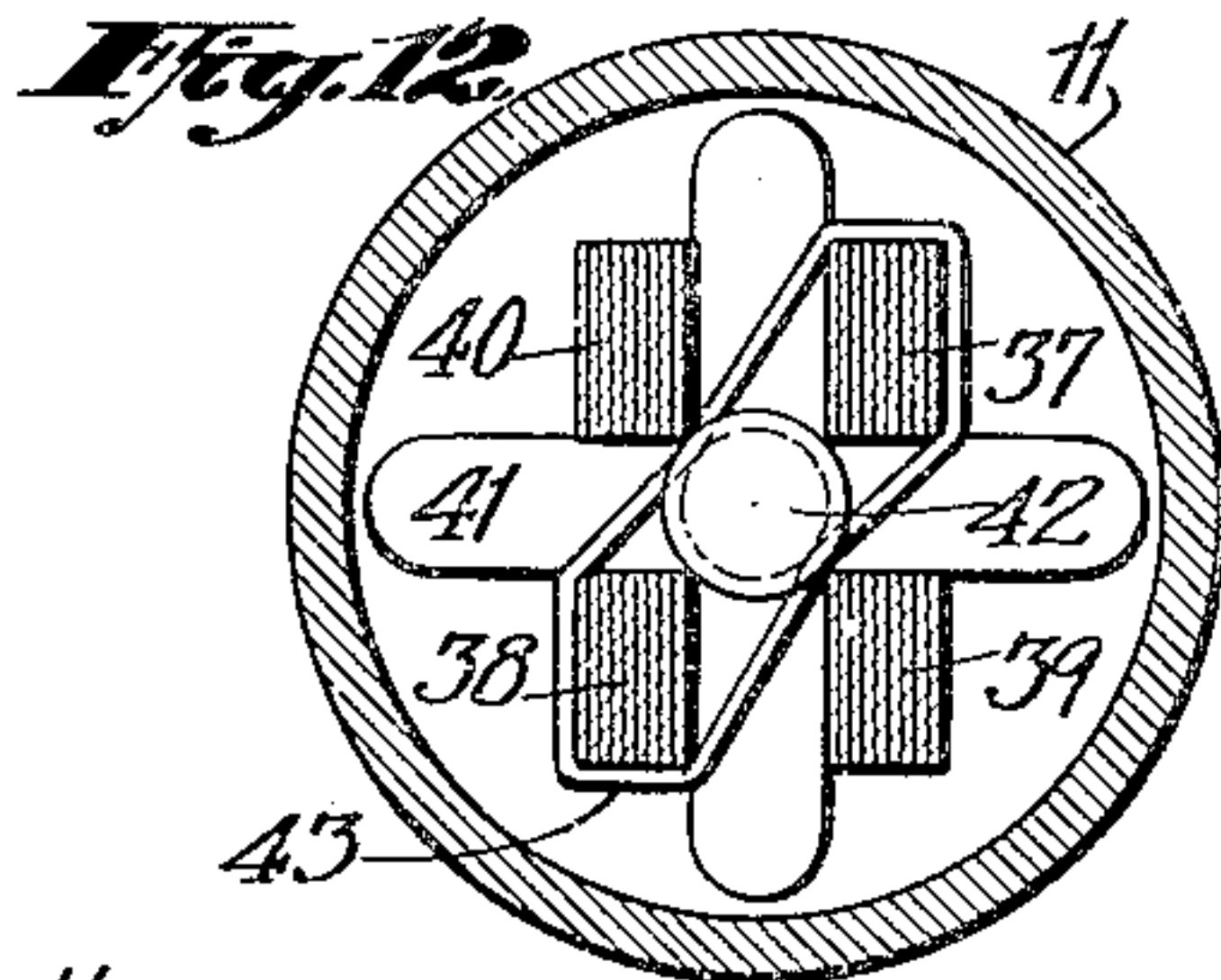
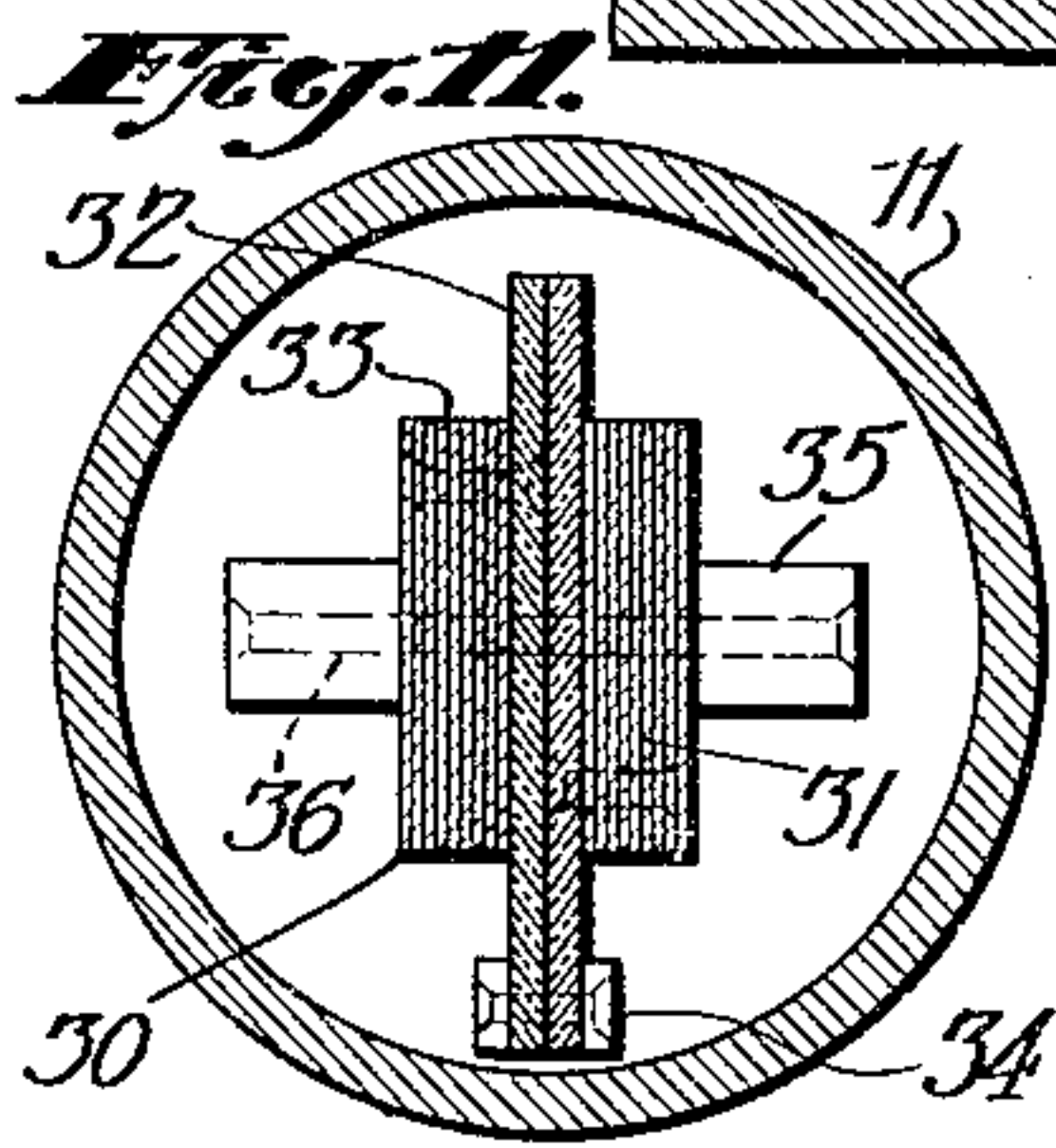
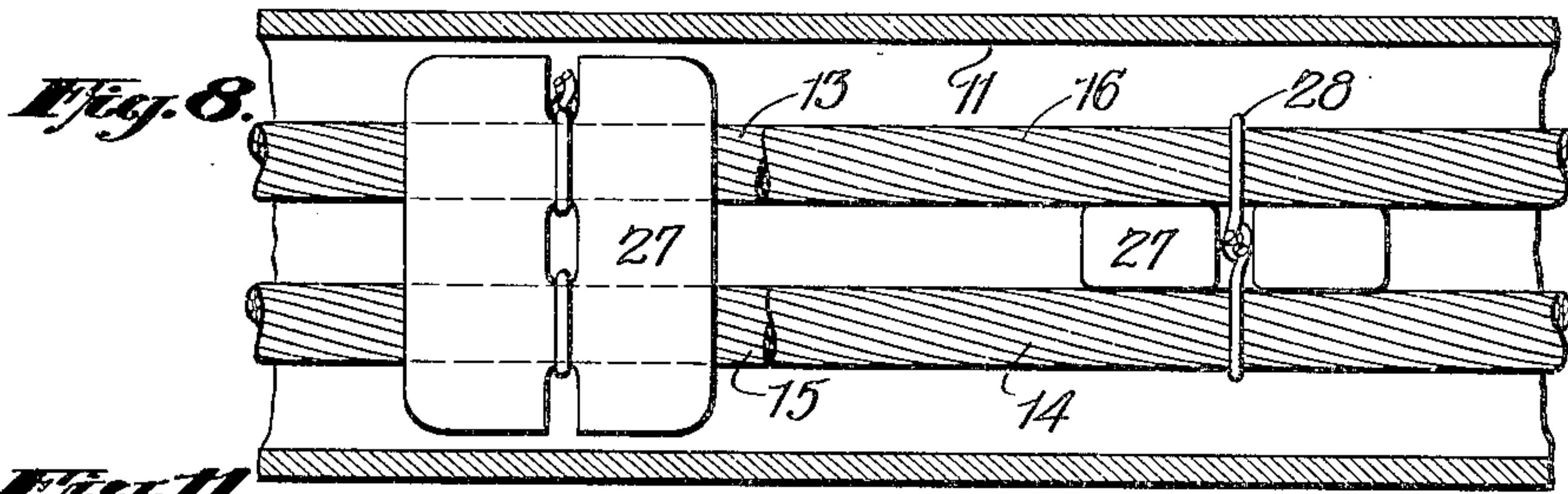
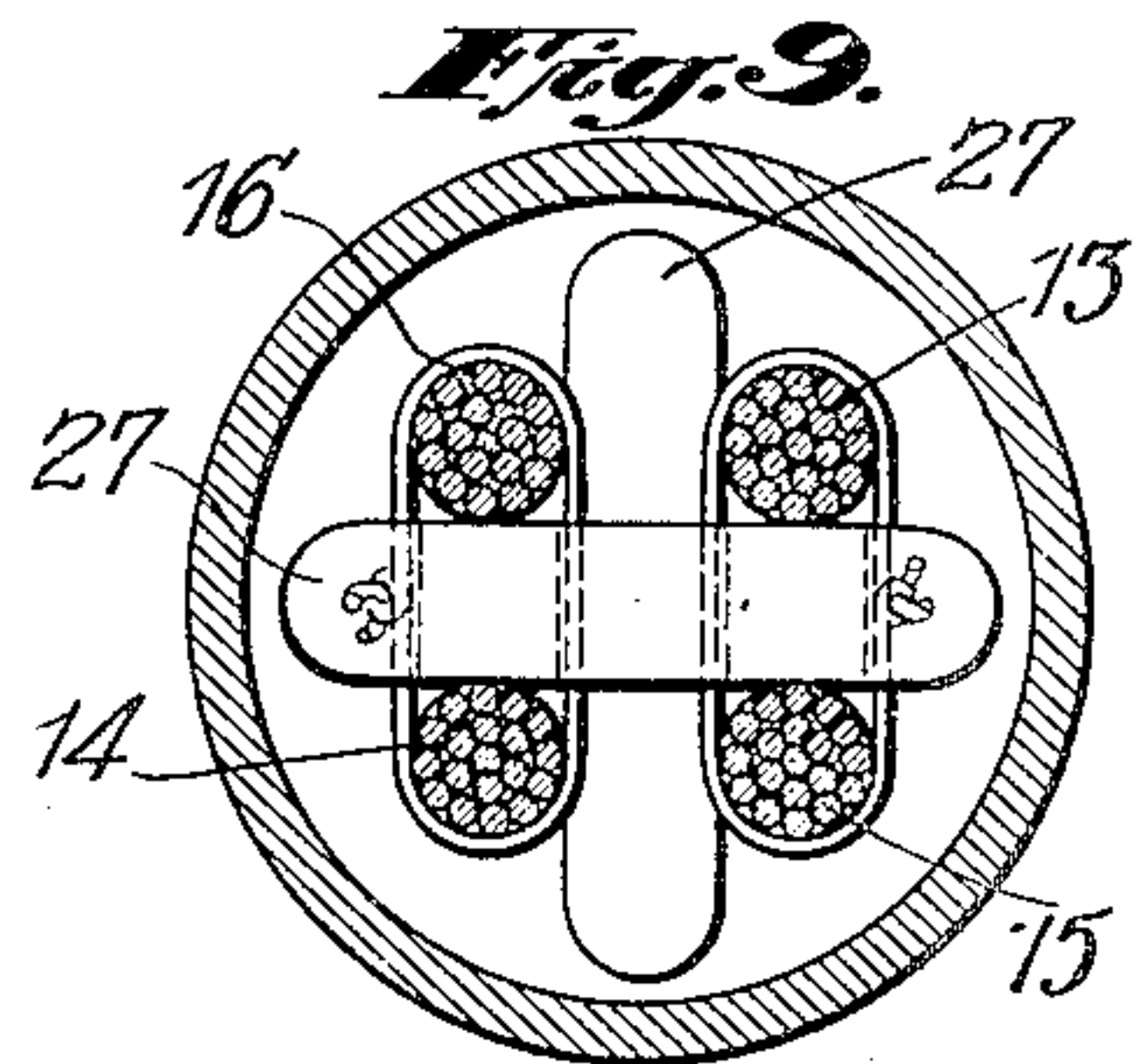
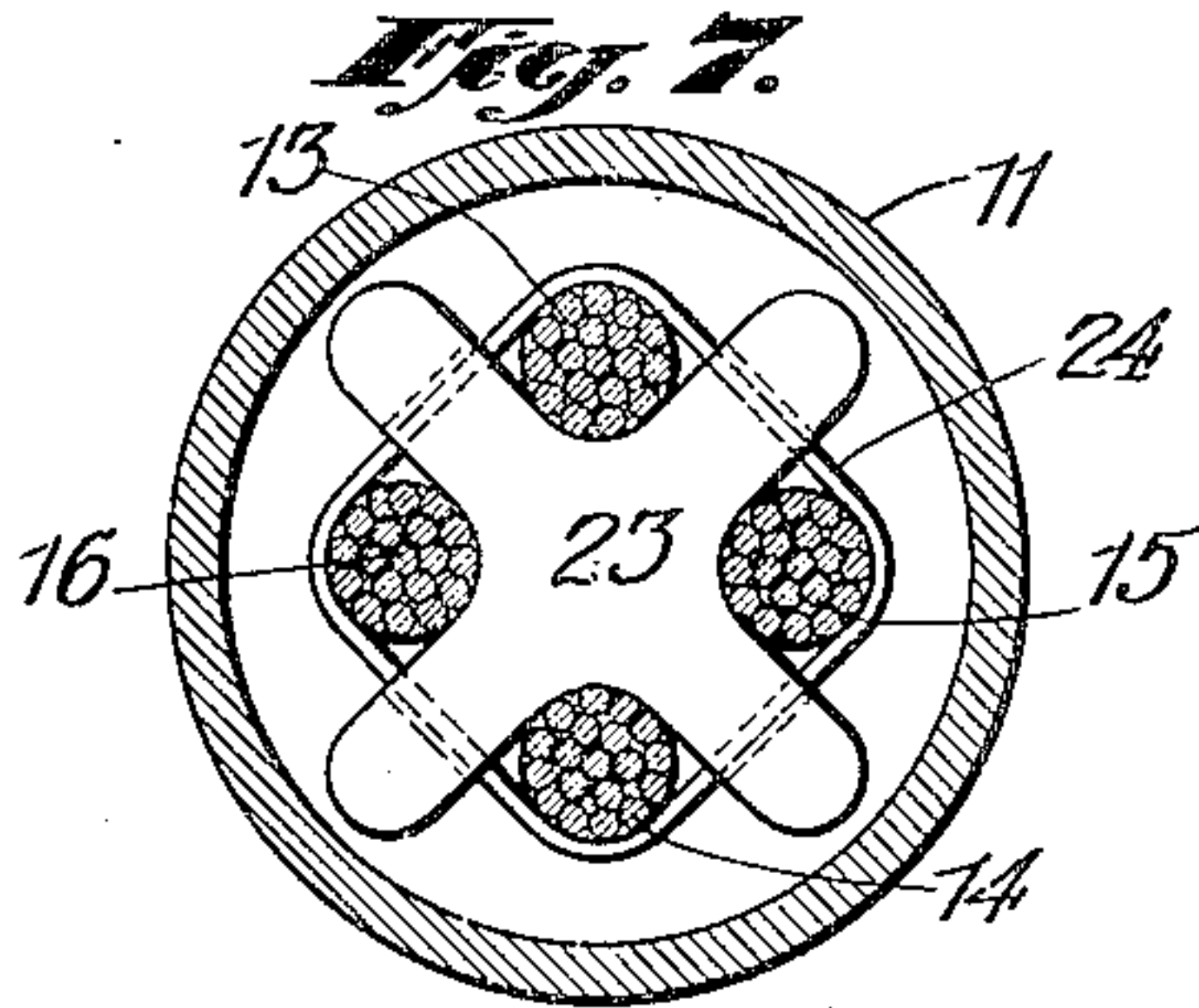
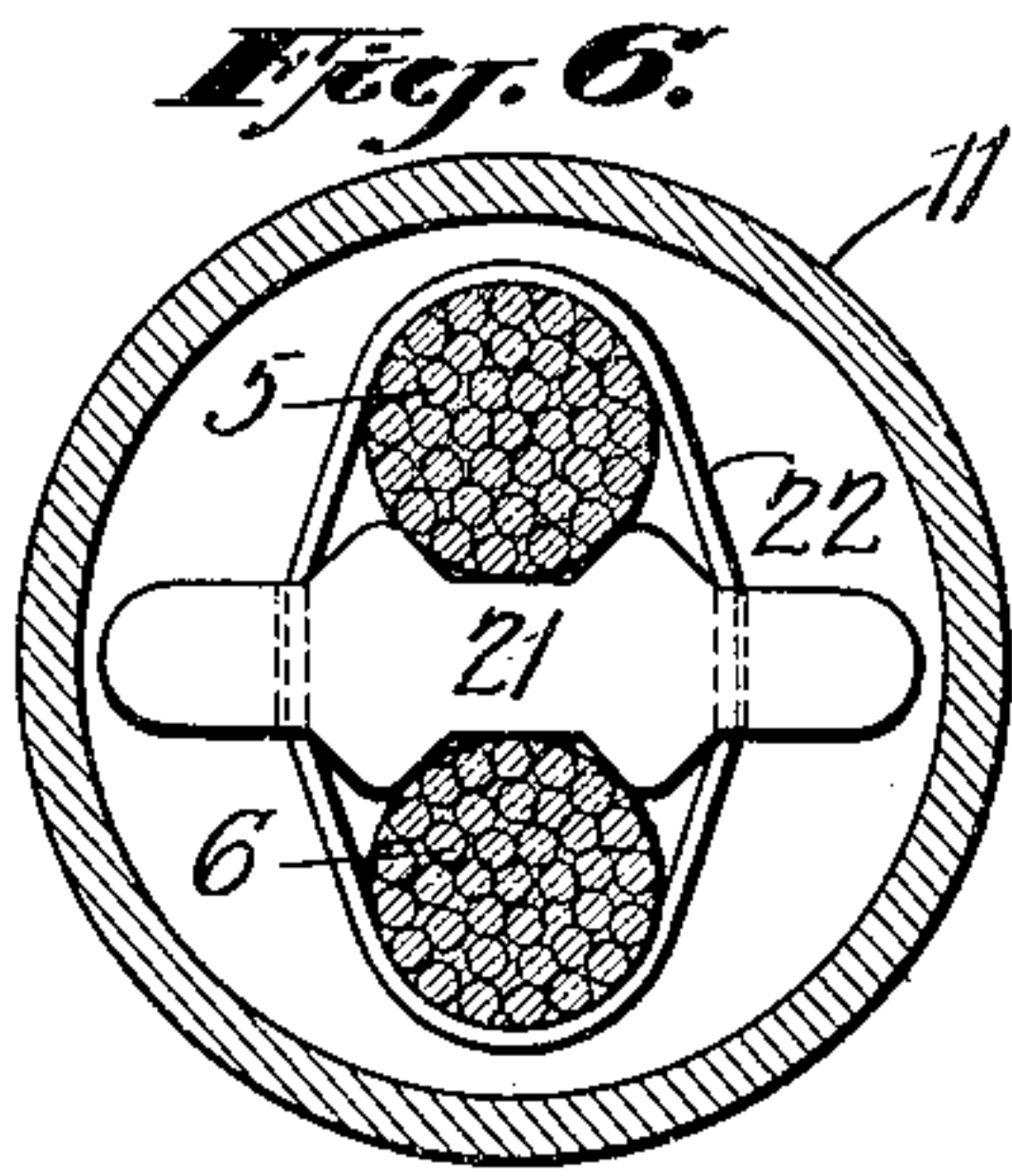

Inventor

THOMAS E. MURRAY.

By His Attorney

R. Anthony Usina

UNITED STATES PATENT OFFICE

THOMAS E. MURRAY, OF BROOKLYN, NEW YORK; JOSEPH BRADLEY MURRAY, THOMAS E. MURRAY, JR., AND JOHN F. MURRAY, EXECUTORS OF SAID THOMAS E. MURRAY, DECEASED, ASSIGNORS TO METROPOLITAN DEVICE CORPORATION, A CORPORATION OF NEW YORK

ELECTRIC CONDUCTOR

Application filed February 6, 1924. Serial No. 690,893.

Electric conductors in the form of cables, single wires or rods are commonly wrapped with an insulating covering and, for additional protection, carried in iron pipes.

5 The construction now generally used is extremely expensive. I propose to provide a style of conductors which is comparatively simple, which is safe, and which at the same time is much more economical.

10 The accompanying drawings illustrate embodiments of my invention.

Figs. 1 and 2 are respectively a perspective view and a cross-section of a double cable or a two-wire arrangement;

15 Figs. 3 and 4 are respectively a longitudinal and a cross-section of a four-cable arrangement;

Fig. 5 is a perspective view of a slightly different four-cable arrangement;

20 Figs. 6 and 7 are cross-sections of alternative arrangements;

Figs. 8 and 9 are respectively a longitudinal and a cross-section of another style;

25 Figs. 10 and 11 are respectively a longitudinal and a cross-section of a conductor made of flat bars instead of cables;

Fig. 12 is a cross-section of a modification using four such flat conductors;

30 Fig. 13 is a perspective view of a design using two flat conductors;

Fig. 14 is a cross-section of an alternative design.

35 The conductors, which may be bare cables, are carried in a shell of concrete, paper or other nonconducting material and are supported and held properly spaced from one another by insulators fastened to the conductors at intervals and free to move with the latter when the conductors are moved lengthwise of the shell. A cable of this sort is more economical than those generally used and is protected by being supported by the insulators out of contact with the surrounding shell. And if there should be some injury to a part of the cable which caused it to contact with the shell, the latter is a comparatively good insulator so that no great harm will be done. Any leak of current could be located and it would be a comparatively

simple matter to break through the casing and repair the cable and also the shell.

Figs. 1 and 2 show an arrangement for the cables 5 and 6 of the two-wire system.

The cables are supported at intervals by 55 porcelain or other insulating blocks 7 having grooves 8 on their outer faces to hold the cables. Knobs 9 are provided on the ends of the insulating spacers with grooves around them so that the spacers and the cables may be fastened together at proper intervals by 60 ties 10 also of insulating material. A shell 11 of cast concrete or other comparatively cheap insulating material encloses the cables and their spacers, the latter fitting freely 65 within the shell and resting thereon so as to hold the cables out of contact with the shell.

According to Figs. 3 and 4, spacers are used consisting of flexible fabric binders 12 which 70 are wrapped about the opposite cables as shown. Where four cables are used one binder is used for the opposite cables 13 and 14 (Fig. 4), and another, at the next interval, for the alternative pair of cables 15 and 16. To prevent contact with the outer shell the cables may be supported at intervals by 75 rings of porcelain, or by spacers like 8 in Fig. 2, which fit within the shell. The intermediate spacers 12 serve chiefly to prevent 80 the cables from contacting with each other.

Fig. 5 shows four cables which are held at intervals by flat spacers 17 with grooves on their faces and with holes through which pass 85 ties 18 of insulating material which fasten the cables in the grooves and hold the spacers at determined points in the length of the cables. The alternate spacers 17 may be placed at right angles to each other as indicated so that one rests on the bottom of the 90 tube 11 and the other bears against the sides thereof.

Fig. 6 illustrates the use of spacers 21, in the form of flat plates, similar to those of Fig. 2, but with a single groove on each side 95 to accommodate a pair of cables 5 and 6, the latter being tied to the spacer by a tie 22 passing through slots or openings in the spacer.

Fig. 7 illustrates a spacer 23 similar to that 100

of Fig. 1, but used with four cables 13, 14, 15 and 16 which are tied in their grooves and attached to the spacer by a single tie 24.

According to Figs. 8 and 9 plates 27 of porcelain are used as spacers having apertures and slots to receive ties 28 by which they are fastened to the cables. With four cables as shown, the alternate blocks 27 are arranged at right angles to each other.

It will be understood that where a plurality of cables are illustrated, these may be all parts of one conductor in effect; that is all carrying a plus current or all a minus current. Or some of them may be plus and others minus.

Figs. 10 and 11 illustrate the use of a pair of conductors 30 and 31 each in the shape of a laminated bar. They are spaced apart by plates 32 of insulating fabric, each being attached to one of such plates as by a screw or rivet 33; and the two plates being fastened together at intervals by riveted washers 34. To guard against contact with the sides of the shell 11, blocks 35 which may also be of insulating fabric, are mounted at intervals on the outer sides of the conductors and fastened together as by means of rivets 36.

Fig. 12 illustrates another arrangement using four laminated conductors 37, 38, 39 and 40. They are grouped together around an insulating spacer 41 with four angular grooves receiving the conductors and with a knob 42 on the end by which it is fastened to the conductors and the latter are held in, through ties 43. Such a tie is shown for the opposite conductors 37 and 38 in the figure. Where the conductors engage the next insulator in line, the other two conductors 39 and 40 will be tied to it.

In Fig. 13, the two laminated conductors 44 and 45 are held at intervals between a central flat insulating plate 46 and upper and lower plates 47 which may be attached in any one of various ways.

According to Fig. 14, the two laminated conductors 30 and 31 are spaced apart at intervals by a single plate 48 of insulating fiber and are clamped to this plate by channel shaped pieces 49 also of insulating fiber fastened together by rivets 50 passing clear through from one side to the other.

Any number of branch outlets may be provided and they may be either at right angles to the line or oblique thereto. The invention may be applied to any desired length of an electric line or to any parts thereof. For example, the straight lengths may be made in accordance with this invention and the curved portions made in some other usual or suitable way. Or the curved portions may be made by properly bending the parts herein illustrated.

The invention effects a considerable economy in that the only material of high insulating efficiency used, and therefore the only ex-

pensive material, is the insulators or spacers of porcelain or of equivalent material.

The intervals between the insulating spacers will depend on the flexibility of the conductor, the more flexible conductor requiring support at closer intervals. The shell illustrated may be protected by an outer casing of suitably strong material. Where a plurality of conductors are carried in a single shell, greater security against contact with each other may be obtained by covering one of them with an insulating coating or wrapping of the ordinary sort. In fact, such insulating coating may be applied to single conductors in a shell or to all of the conductors where there are several of them in one outer shell.

Though I have described with great particularity of detail certain specific embodiments of my invention yet it is not to be understood therefrom that the invention is restricted to the particular embodiments disclosed. Various modifications thereof in detail and in the arrangement of the parts may be made by those skilled in the art without departure from the invention as defined in the following claim.

What I claim is:—

A device for holding electric cables which comprises an insulating spacer block having opposed longitudinal grooves for said cables, wings projecting radially from said block between said grooves and longitudinally projecting posts at the ends of said block, and means for securing said cables to said posts.

In witness whereof, I have hereunto signed my name.

THOMAS E. MURRAY.

70

75

80

85

90

95

100

105

110

115

120

125

130