

Feb. 16, 1932.

L. WEISNER ET AL

1,845,947

MESSAGE PROTECTOR

Filed Feb. 14, 1929

4 Sheets-Sheet 1

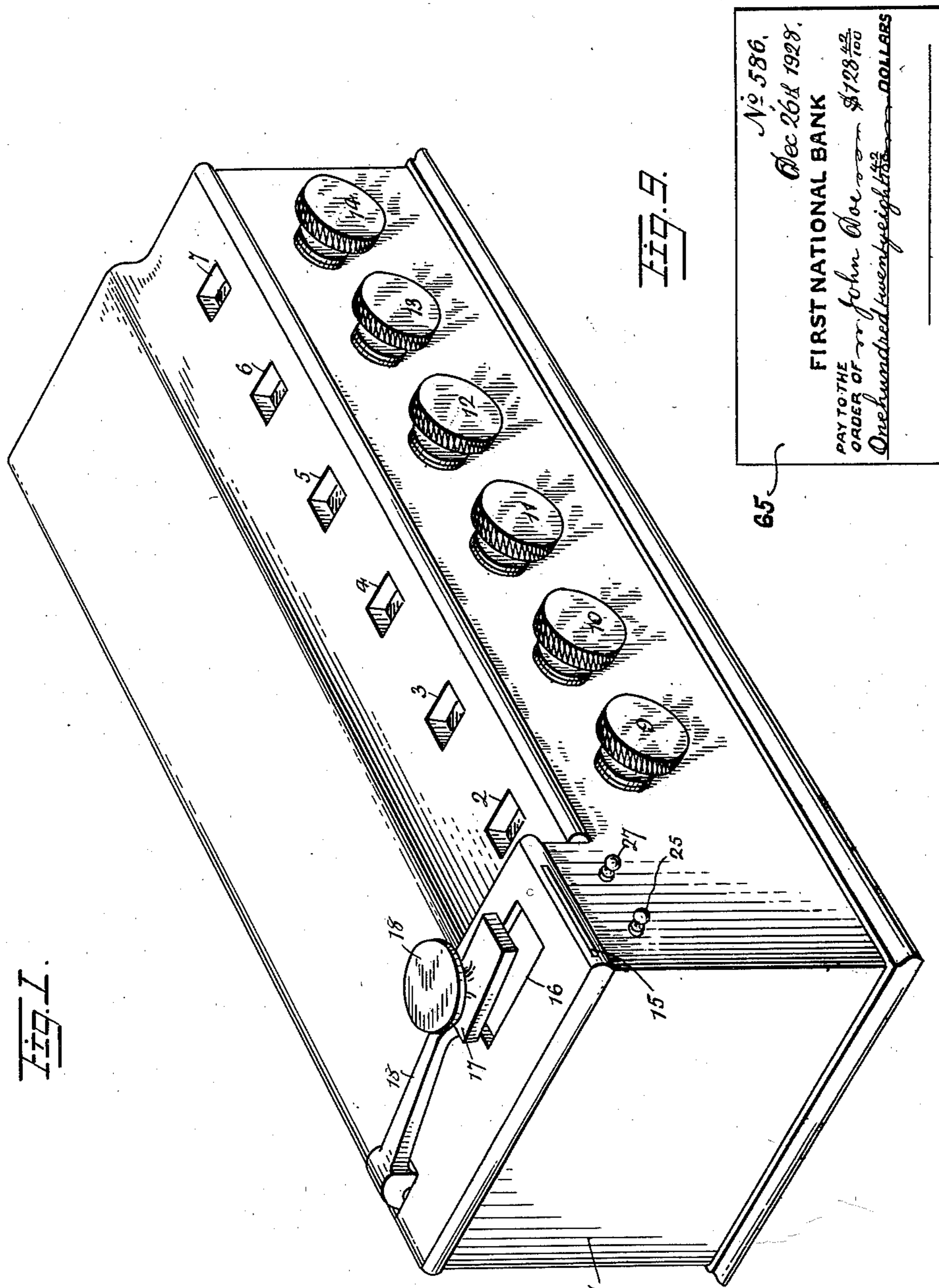

No. 586,
Dec 26th 1928.
FIRST NATIONAL BANK
PAY TO THE
ORDER OF Mr. John Doe \$128 ⁴²/₁₀₀
One hundred twenty eight ⁴²/₁₀₀ DOLLARS

WITNESSES
H. J. Walker
A. L. Kitchen

Louis Weisner and
Lester S. Hill
INVENTORS

BY *Mum & Co.*
ATTORNEY

Feb. 16, 1932.

L. WEISNER ET AL

1,845,947

MESSAGE PROTECTOR

Filed Feb. 14, 1929

4 Sheets-Sheet 2

Fig. 2.

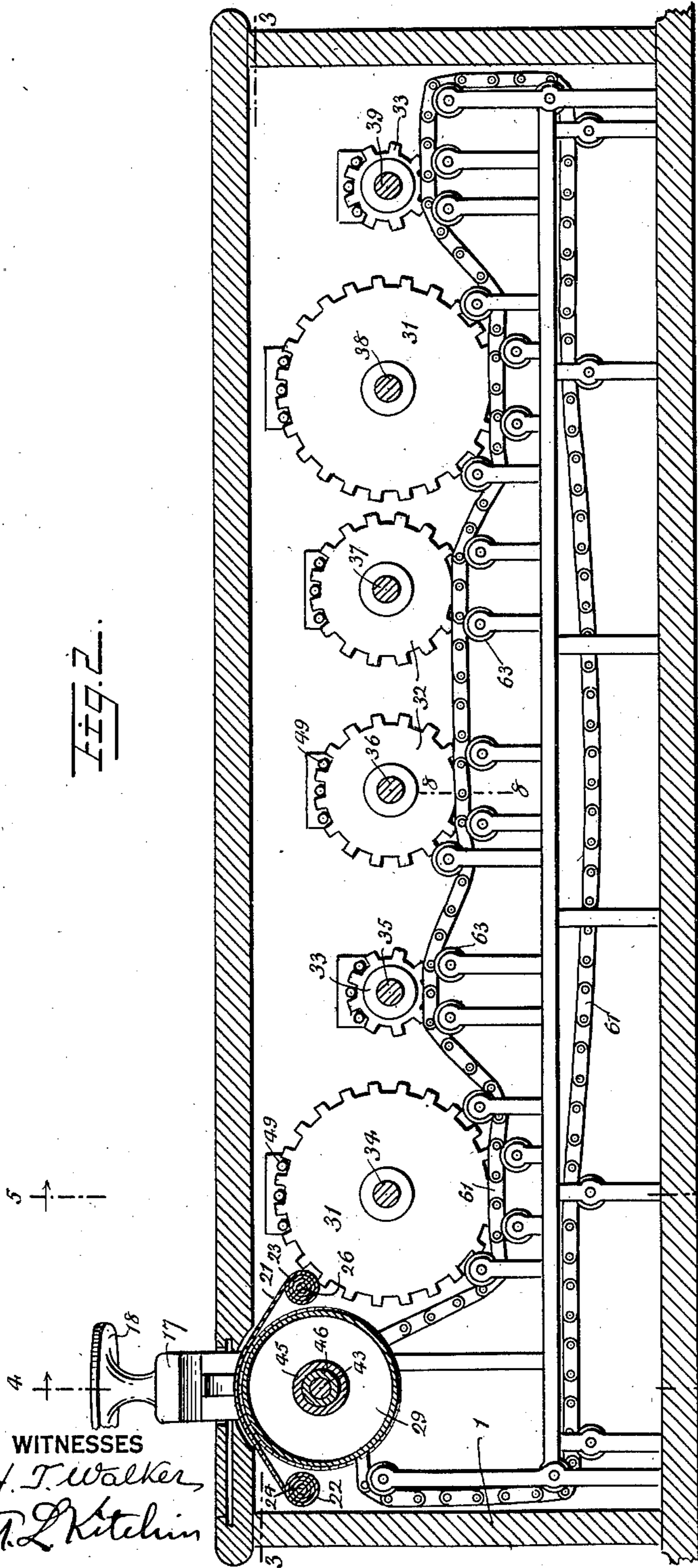

WITNESSES
H. T. Walker
A. L. Kitchin

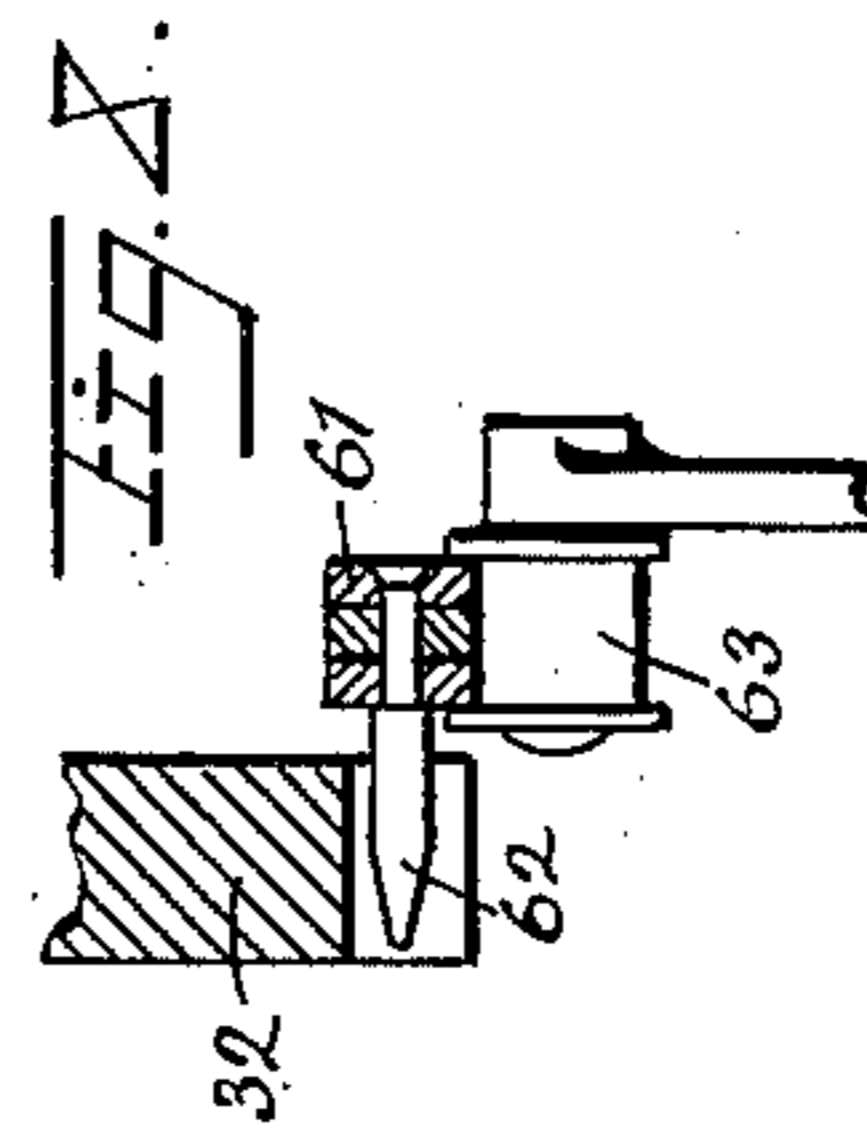
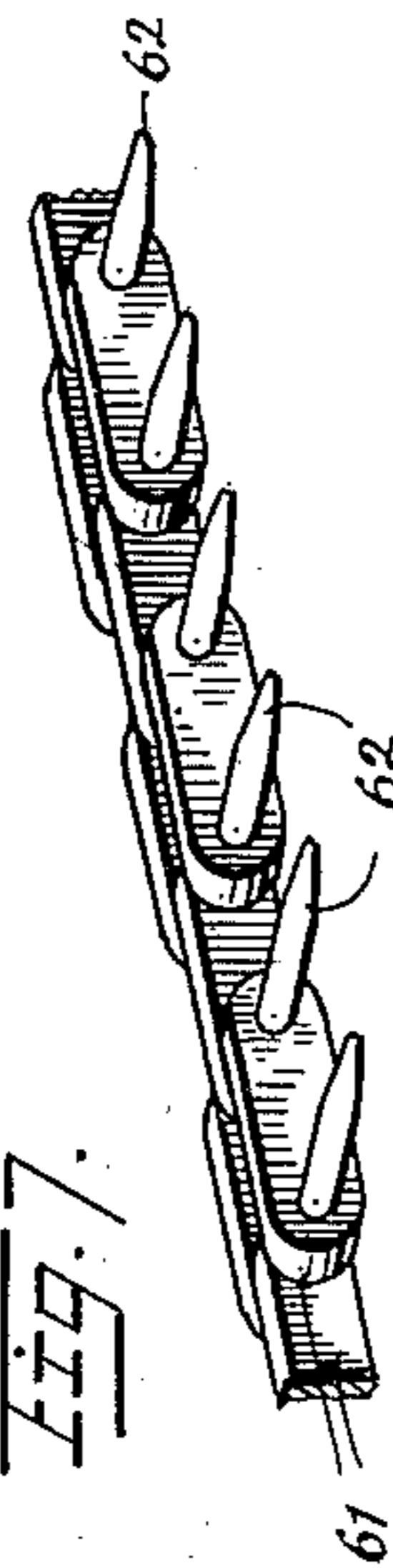

Fig. 7.



Louis Weisner and
Lester S. Hill
INVENTORS

BY *Mumford*
ATTORNEY

Feb. 16, 1932.

L. WEISNER ET AL

1,845,947

MESSAGE PROTECTOR

Filed Feb. 14, 1929

4 Sheets-Sheet 3

FIG. 3.

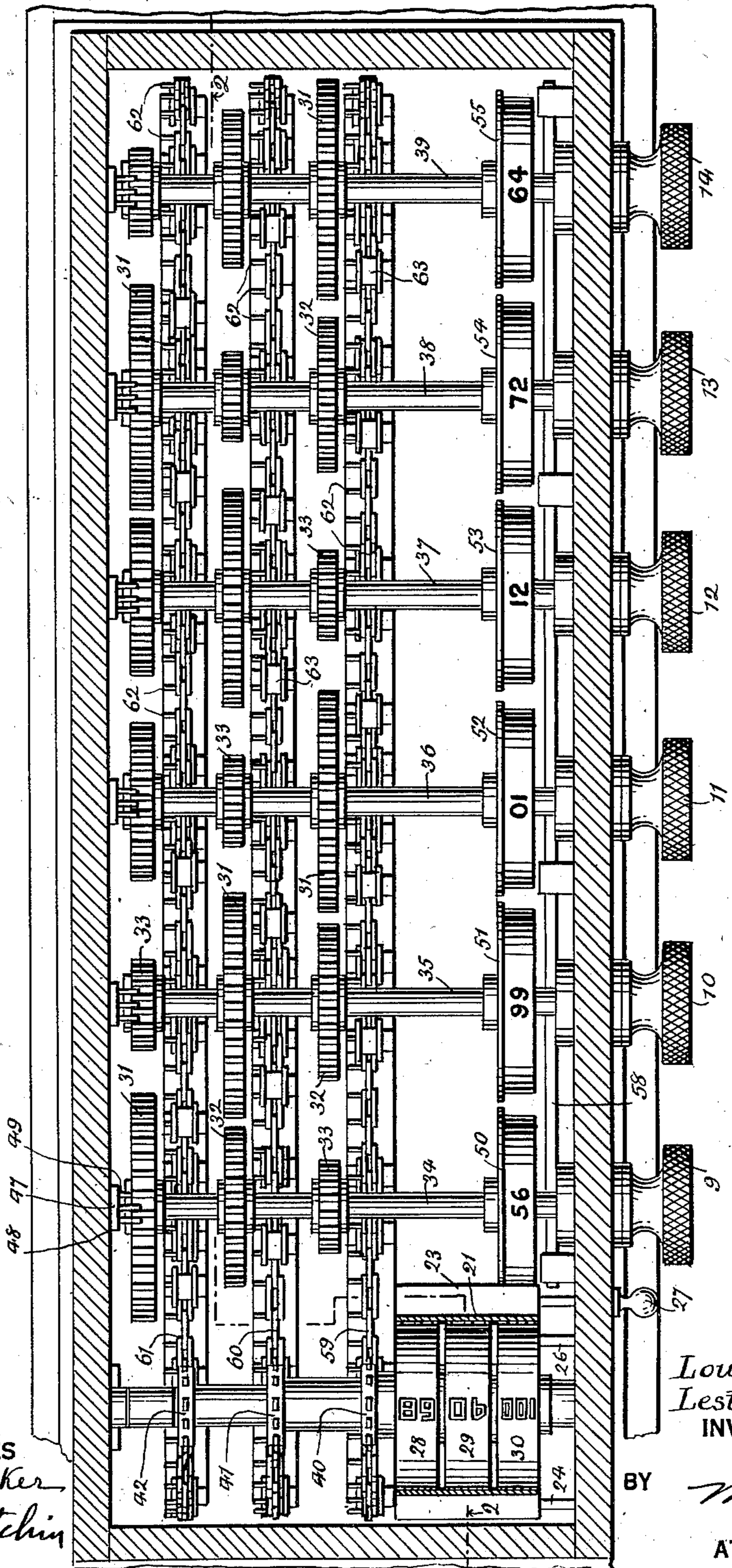

WITNESSES
H. T. Walker
A. L. Mitchin

*Louis Weisner and
 Lester S. Hill*
 INVENTORS

BY *Munster*
 ATTORNEY

Feb. 16, 1932.

L. WEISNER ET AL

1,845,947

MESSAGE PROTECTOR

Filed Feb. 14, 1929

4 Sheets-Sheet 4

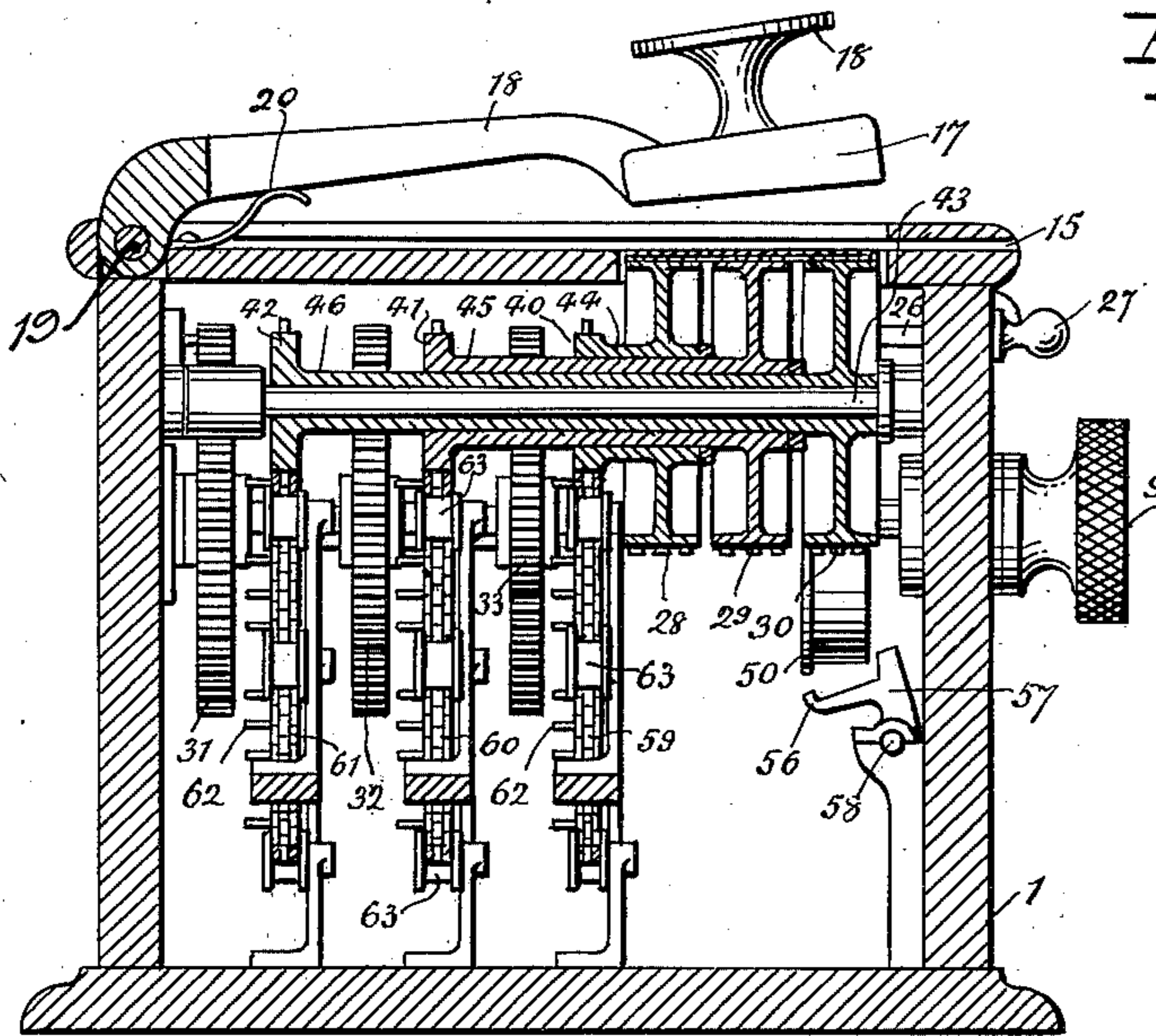

Fig. 4.

Fig. 5.

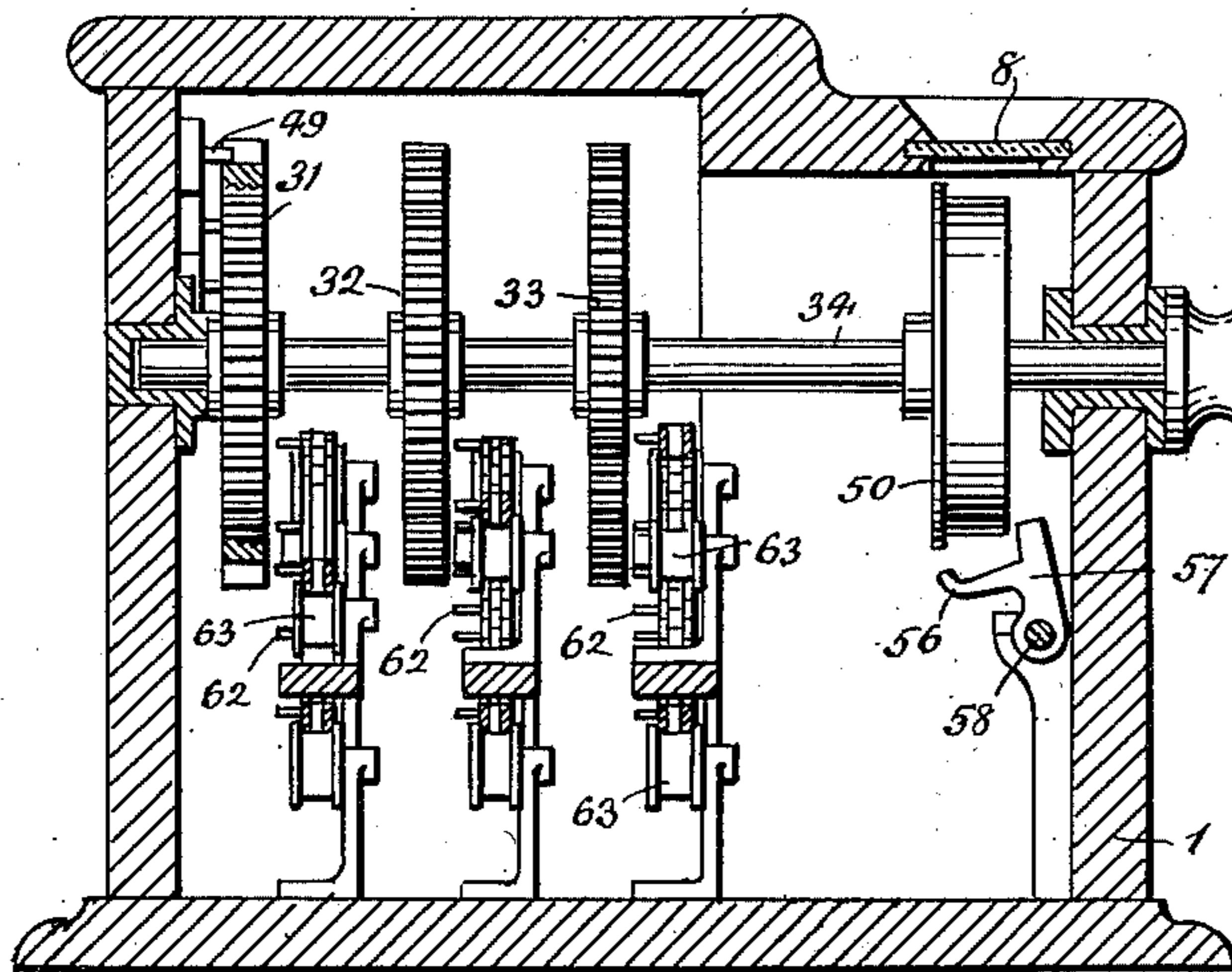
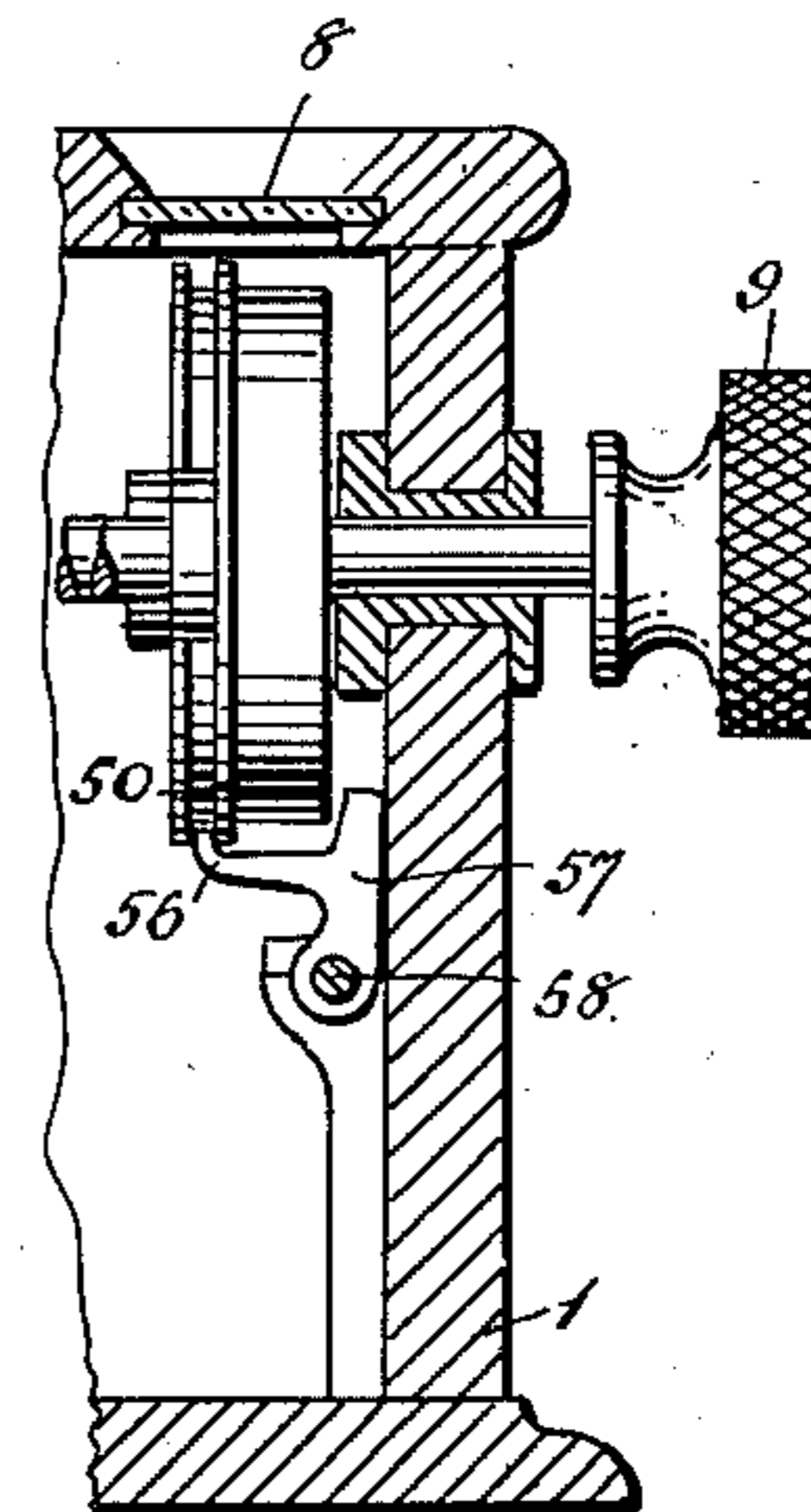

Fig. 6.



Louis Weisner and
Lester S. Hill.
INVENTORS

WITNESSES

A. T. Walker
A. L. Kitchen

BY *Mumford Co.*

ATTORNEY

UNITED STATES PATENT OFFICE

LOUIS WEISNER AND LESTER S. HILL, OF NEW YORK, N. Y.

MESSAGE PROTECTOR

Application filed February 14, 1929. Serial No. 339,929.

This invention relates to what may be termed a message protector, and has for an object to provide a mechanism for grouping symbols to be used on bank checks, code messages or other messages or on any communication to indicate its authenticity and accuracy.

Another object of the invention is to provide an improved machine to be used in connection with checks or other messages, the machine presenting a mechanism wherein an almost indefinite number of combinations may be used to group symbols or numbers to be printed on the check or other message.

A further object is to provide a message protector capable of computing simultaneously the numerical values or equivalent symbols of one or more linear functions of a proposed sequence of numbers, the evaluation being effected with respect to a modulus.

An additional object, more specifically, is to provide a machine to be operated by the hand, the arrangement being such that printing members are provided and positioned so that they may be shifted according to a great number of combinations and thereby present an indication or code message or symbol to be applied to checks or other messages to indicate their accuracy and authenticity, or to translate a proposed message into cipher and back again.

A further additional object is to provide an improved machine for converting a message into a cipher message and for re-converting the cipher message into the original form of message.

In the accompanying drawings,—

Figure 1 is a perspective view of a message protector disclosing an embodiment of the invention;

Figure 2 is a longitudinal vertical sectional view through Figure 3 approximately on line 2—2;

Figure 3 is a horizontal sectional view through Figure 2 on line 3—3, the same disclosing in top plan the mechanism of the protector shown in Figure 1;

Figure 4 is a transverse sectional view through Figure 2 on line 4—4;

Figure 5 is a transverse sectional view through Figure 2 on line 5—5;

Figure 6 is a sectional view similar to the right-hand part of Figure 5 but showing the parts in a shifted position;

Figure 7 is an enlarged detail fragmentary perspective view of part of one of the chains shown in Figure 3;

Figure 8 is a fragmentary sectional view through Figure 2 approximately on the line 8—8; and

Fig. 9 is an illustration of a check.

Referring to the accompanying drawings by numerals 1 indicates a casing enclosing the various mechanism shown in Figures 3 to 8 inclusive. This casing is provided with openings 2, 3, 4, 5, 6 and 7, which openings act as windows through which certain parts of the mechanism shown in Figure 3 may be viewed. As illustrated in Figures 5 and 6 a transparent member 8 is provided in each window so as to permit an inspection of the wheels arranged beneath the respective windows while keeping dust and dirt from the interior of the casing. As shown in Figure 1, there are disclosed six knobs, namely, knobs 9, 10, 11, 12, 13 and 14. These knobs are connected to suitable shafts hereinafter fully described, whereby the mechanism may be operated by the hand from the exterior of the casing. An opening 15 is provided and acts as an entrance for a check or other article. An opening 16 is provided through which the presser or impact plate 17 moves when the knob 18 is struck or forced downwardly. This action takes place when a number or symbol is to be printed on a check or other article inserted through slot 15. As illustrated particularly in Figure 4, the plate 17 is formed integral with or rigidly secured to the arm 18 pivotally mounted at 19 on casing 1 and normally held in an elevated position by a spring 20. The printing mechanism will be hereinafter fully described and may be of any suitable or desired type. As shown in the drawings, a ribbon 21 (Figure 2) is provided and is adapted to be wound on rollers 22 and 23. The roller 22 has shaft 24 extending to the exterior of the casing 1, as shown in Figure 1, and a suitable knob 25 is connected therewith,

whereby the roller 22 may be rotated by hand at any time. Similarly, a shaft 26 is connected with roller 23 and is provided with a knob 27 whereby the ribbon may be moved in a reverse direction. The action of the ribbon and associated parts simulates rather closely the usual action of an ordinary typewriter.

It is aimed to rotate the various printing wheels or rollers 28, 29 and 30 and the angle of rotation of these wheels depends upon the number of the various knobs 9 to 14 and certain other parts fully described hereinafter. The printing wheels 28, 29 and 30 carry different numbers or symbols which are adapted to print on the check or other article. As shown in Figure 3, the printing wheel 28 is disclosed with the number 68 thereon said number facing upwardly, while printing wheels 29 and 30 are provided with numbers 40 and 100 respectively. When the presser plate 17 is actuated all of these numbers will be simultaneously printed on the check and a legend will therefore be provided upon a check which will be, in the present instance, "1,004,068". On each of the printing wheels 28 to 30 there are provided numbers "00" to "100", but for the lack of space all of these numbers have not been shown but only a few in order to illustrate the principle involved. These numbers are provided for the reason that they agree with the various mechanisms hereinafter described, and particularly with the toothed or actuating wheels 31, 32 and 33 upon each of the shafts 34, 35, 36, 37, 38 and 39. As one example, the actuating wheel 33 should be provided with 101 teeth, the actuating wheel 32 with 202 and the actuating wheel 31 with 303 teeth. The indicating or answer wheels 40, 41 and 42 should each be provided with 101 teeth. It is to be understood that a specific structure is being described with a specific number of teeth, but, if desired, the number of teeth could be changed, following certain mathematical principles, and the same or other desirable results secured. Also, instead of using numbers, letters or other symbols could be used, but for the purpose of description numbers have been used and it will be understood that when the printing wheels 28 to 30 are mentioned, numbers, symbols or legends of any kind may be used thereon. As shown in Figure 4, a shaft 43 is provided on which the respective tubular shafts 44, 45 and 46 are mounted, said tubular shafts being positioned to telescopically fit into each other, so that the answer wheels 40 to 42 inclusive will be properly spaced, as shown in Figure 3. This arrangement will permit each of the printing wheels 28 to 30 to be independently moved in either direction. As shown in Figure 3, shaft 34 has rigidly secured thereto respective actuating wheels 31 to 33 and these actuating wheels are arranged so that actuating

wheel 33 is nearest to the knob 9, actuating wheel 31 is furthest from knob 9 and actuating wheel 32 is intermediate the other actuating wheels. In regard to shaft 35, the small actuating wheel 33 is furthest from knob 10, while the large actuating wheel 32 is intermediate and the medium-sized actuating wheel 31 is nearest knob 10. The actuating wheels on the shafts 36 to 39 inclusive are arranged in various orders as shown in Figure 3, but, if desired, could be arranged in some other order without departing from the spirit of the invention. Associated with each of the actuating wheels furthest from their respective knobs 9 to 14 is a lock or clutch 47. This lock or clutch may consist merely of a plate 48 having a number of spaced pins 49 extending therefrom adapted to fit in between certain of the teeth of the actuating wheels when the knobs 9 to 14 are forced to a position against the casing 1, as shown in Figure 3. This arrangement locks the various shafts 34 to 39 inclusive, so that they cannot be rotated. In order to rotate any of these shafts the knob connected therewith must be pulled outwardly a sufficient distance to disengage the clutch 47 from the adjacent actuating wheel. In order that the printing wheels 28 to 30 inclusive may be caused to function properly means have been provided for locking all of the shafts 34 to 39 inclusive except the one which has been moved longitudinally as the knob is pulled outwardly. As shown in Figures 5 and 6, the various code wheels 50, 51, 52, 53, 54 and 55 are provided with flanges coacting with the stop or extension 56 of the respective pawls 57. There is a pawl 57 for each of the wheels 50 to 55 inclusive and all these pawls are rigidly secured to a freely rockable shaft 58 journaled in suitable bearings near each end of the casing 1. When the knob 9, for instance, is pulled outwardly, as shown in Figure 6, the outer edge of the wheel strikes the pawl 57 and swings the pawl from the position shown in Figure 5 to the position shown in Figure 6. This will result in the movement of the abutment 56 to a position in back of the flange of wheel 50, and also will result in positioning the abutments 56 of all the other pawls to a position in front of the various flanges so that the knobs, shafts and associated parts of all the remaining mechanisms cannot be moved outwardly. As soon as the knob 9 has been pushed back the next knob or any knob may be pulled outwardly and rotated in either direction.

Coacting with each of the answer or remainder wheels 40 to 42 inclusive are driving means, as for instance, chains 59, 60 and 61, said chains being continually in mesh respectively with the answer wheels 40, 41 and 42. These chains are supported on suitable idlers 63 and are preferably made endless, as shown in Figure 2. Normally the various actuating

wheels 31 to 33 inclusive are out of mesh with these chains and are only brought into mesh when any of the knobs 9 to 14 inclusive are moved outwardly. It will thus be seen that when a knob is moved outwardly the parts associated therewith are disengaged from the lock 47 and at the same time engage with the respective chains 59 to 61 inclusive. Each of these chains is formed as shown, for instance, in Figures 7 and 8. From these figures it will be observed that an ordinary chain structure is provided having pins or projections 62 spaced apart a proper distance to receive the teeth of the actuating wheels 31 to 33 inclusive. If, for instance, knob 9 is pulled outwardly and then rotated one revolution the actuating wheel 33 would naturally rotate one revolution and move its chain forwardly a distance equal to 101 teeth. The actuating wheel 40 will rotate through the same angle, as it is of the same size and has the same number of teeth. While this is taking place the actuating wheel 32 will perform one complete rotation, but as it has 202 teeth the chain associated therewith will be moved so that the answer wheel 41 will rotate two revolutions. While these two operations are taking place a third operation will be taking place, namely, actuating wheel 31 will rotate one revolution and as it has 303 teeth answer wheel 42 will rotate three times. If knob 9 is not rotated a complete revolution but only a part of a revolution a proportionate action of the various wheels will take place. After knob 9 has been rotated, as desired, it is returned to its former position, as shown in Figure 3, and then knob 10 is pulled outwardly and rotated, as desired. This action is repeated for all of the knobs and then the check or other article is moved into the casing through slot 15. The printing is then done by merely striking the knob 18. The check is then removed and a number will be found thereon agreeing with the combination produced by the various numbers of the knobs 9 to 14 inclusive. This number is really in effect the remainder or answer left over from the various additions, subtractions and other actions performed by the mechanism described.

When the device is in actual use it may be operated by persons in a bank or by persons anywhere. Where the device is used as a check or safety guard for checks drawn on banks one device is necessary for the bank and one for the person drawing the check. Also, in addition to having identical devices, the bank and the person drawing the check should have a code sheet giving arbitrary values to the numbers or symbols on the code wheels 50 to 55. It will be understood that these code wheels carry numbers similar to the numbers on printing wheels 28 to 30, said numbers being preferably from 00 to 100. Where numbers are used they are arranged

so that two numerals will appear in the windows or openings 2, 3, 4, 5, 6 and 7 simultaneously. The bank and the person drawing the check are provided with identical code sheets and with devices embodying the invention. The person drawing the check will draw the same in the usual manner, giving the check a number, date, and indicating thereon the sum of money to be paid, and then operate the machine to secure a code number, which number is stamped on the check. Where the check is drawn, as shown in Fig. 9, the number of the check, the sum in dollars and the date form the means for guiding the drawer of the check in manipulating the device. After the check has been drawn the drawer takes down the chart and finds that the number 1 indicates 56 on the code wheels 50 to 55 and the numbers 28, 5, 86, 26, 28 represent on the code wheels 51 to 55 the respective numbers 99, 01, 12, 72 and 64. Having ascertained from the chart that 1 indicates 56 he disregards the 42¢ of the check and starts with 1 from the \$128.00 indicated. Knob 9 is pulled outwardly and rotated until 56 comes opposite window 2, as shown in Figure 3. Knob 9 is then pushed in and knob 10 pulled outwardly and rotated in either direction until the numeral 99 appears opposite the window. Knob 10 is then pushed back and knob 11 pulled out and rotated until the numeral 01 appears opposite the window. Knob 11 and associated parts are returned to their former position and knob 12 pulled out and rotated until the numeral 12 appears opposite the window. Knob 12 is returned and knob 13 pulled outwardly and rotated until the numeral 72 appears opposite the window. Knob 13 is returned and knob 14 pulled outwardly and rotated until the numeral 64 appears opposite the window. In the code 1 equals 56 and this 1 is taken from the \$128.00 found on the check. The next two numerals, namely, 28 are used in connection with knob 10. The numeral 5 in the number of the check is then used for knob 11 and this is followed by knob 12, utilizing the number 86 which forms the latter part of the number of the check. The number 26 in the date is utilized for knob 13, while the last two numbers, 28 of the date are utilized for knob 14. It will thus be seen that the number of knobs 9 to 14 is controlled, first, by the number of dollars indicated, second, by the number of the check, and third, by the date of the check. If any one of these numbers on the check were changed the particular knob involved would be rotated a greater or less number of times, and consequently, the final number or remainder on the printing wheels would not be the same. This would indicate to the bank when they use the same system as the drawer, that someone had tampered with the check. It will be understood that the drawer uses the figures on the check as mentioned, in order to secure the proper symbol or legend to

be printed on the check by the printing wheels 28 to 30. The bank will likewise use the same numbers on the check and if the symbol or legend secured on their printing wheels is the same as the symbol produced by the drawer the bank is satisfied that the check is authentic. The operation of the device has been described in respect to checks, as the device is particularly adapted to be used in connection with checks, but it is to be understood that the device can be used with telegraph messages either in plain language or in code or on any papers and documents where authenticity and accuracy are necessary. It will, therefore, be understood that when the word "check" is used these other uses are understood.

Where the device is planned to be employed for the purpose of converting a proposed message into a cipher and back again, it is planned to have as many chains and printing rollers as there are shafts, let us say for illustration, six by six. The twenty-six letters of the alphabet (or a greater or smaller number if additional symbols or other alphabets are employed) will appear on the code wheels 50 to 55 inclusive (Figure 3) and on the printing wheels 28 to 30, there now being six printing wheels instead of three. On the shafts 34 to 39 inclusive six actuating wheels appear instead of the three actuating wheels 31, 32, 33, the number of teeth on each actuating wheel being a multiple of 26 or any other chosen modulus, while the number of symbols on the printing apparatus is exactly 26, or the number represented by the modulus chosen.

A message to be transmitted by cipher is first divided into sets of six symbols. Suppose the sequence "WHEELS" is part of this message. This sequence may first be changed by means of some prearranged cipher, known to the correspondents, into some sequence such as "AMSSPB". The machine is now applied: knob 9 is pulled out and rotated until "A" appears, and is pushed back; knob 10 is pulled out and rotated until "M" appears; knob 11 is pulled out and rotated until "S" appears; knob 12 is pulled out and rotated until "S" appears and is pushed back; knob 13 is pulled out and rotated until "P" appears; and is pushed back; knob 14 is pulled out and rotated until "B" appears and is pushed back. If the knob 18 (Figure 1) be struck, there will be printed on a sheet of paper inserted in the slot 15 a sequence of six symbols such as "XRSMYR". This sequence may then be converted by means of a second prearranged cipher into a sequence of six symbols, such as "PTUNAT". This is the message which is transmitted. The recipient of the message, wishing to decipher "PTUNAT", first employs the inverse of the second prearranged cipher to convert this sequence into "XRSMYR". He then places this sequence

in his machine, which may be but is not necessarily an exact duplicate of the sender's machine, that is, he operates knobs 9 to 14 inclusive (Figure 1) in the manner already described, so that the letters X, R, S, M, Y, R, appear in the openings 2, 3, 4, 5, 6, 7, respectively. Because the sizes of the actuating wheel have been chosen according to certain mathematical principles, his machine will print "AMSSPB" which is precisely the sequence which the sender placed in his machine. By applying to this sequence the inverse of the first prearranged cipher, it is translated into "WHEELS".

In the accompanying drawings a machine has been shown with six shafts and each shaft has been shown as being provided with three wheels of certain sizes, but it will be understood that the number of shafts may be varied at will according to certain mathematical principles, and also the number of wheels on each shaft. For some purposes only one printing wheel is necessary and one or more shafts with a single wheel on each shaft, while in other instances two shafts or even more than six may be used. Where only accuracy is desired one or two printing wheels will be ample and one or two actuating wheels on the respective shafts will be ample, but where it is imperative to maintain the message secret more shafts and more wheels are desirable.

With the above recited and other objects in view, the invention resides in the novel construction set forth in the specification, particularly pointed out in the appended claims and illustrated in the accompanying drawings, it being understood that the right is reserved to embodiments other than those actually illustrated herein, to the full extent indicated by the general meaning of the terms in which the claims are expressed.

What we claim is:—

1. A cryptographic device, including a plurality of printing wheels, each wheel having a number of symbols thereon, a shaft connected to each wheel, an answer wheel connected to each shaft, said answer wheels all having the same number of teeth, a plurality of hand-operated shafts, a code wheel carried by each of said shafts, a plurality of actuating wheels carried by each shaft, there being an actuating wheel on each shaft for each of said answer wheels first-mentioned, and means for transmitting motion from the actuating wheels on the shafts to said answer wheels, so that said answer wheels and said printing wheels will move through certain angles according to the relative size of the wheels on the shafts and said answer wheels.

2. A cryptographic device including printing wheels formed with numbers thereon, an answer wheel connected with each of said printing wheels, said printing wheels being of the same size and all of said answer wheels

being of the same size, each of the answer wheels having teeth the number of which is equal to a fixed modulus, a plurality of code wheels having numbers thereon indicating symbols, a shaft for each of said code wheels, hand-operated means for each shaft, whereby each shaft may be rotated independently to secure different combinations on said printing wheels, an actuating wheel carried by each shaft for each of said answer wheels, said actuating wheels having teeth the number of which is a multiple of the teeth of said answer wheels, and means for transmitting motion from said actuating wheels to said answer wheels when said shafts are rotated, whereby said printing wheels will be moved through different angles in direct proportion to the movement of each of the various shafts.

3. A cryptographic device, including a plurality of shafts, a hand-operated knob for each shaft for rotating said shafts, a numbered code wheel carried by each shaft, a plurality of actuating wheels rigidly secured to each shaft, said actuating wheels having sizes which are equal to or multiple of the size of some one of them, the actuating wheels on one shaft being in alignment with the actuating wheels on the other shaft, the actuating wheels of the respective shafts being arranged so that actuating wheels of different diameters will be arranged adjacent each other, a driving mechanism for each row of aligned wheels, each of said shafts being slidable longitudinally so as to move the respective actuating wheels into and out of engagement with said driving mechanism, means for preventing said shafts and their respective actuating wheels from rotating until brought into engagement with said driving mechanism, said means causing only one set of actuating wheels to engage said driving mechanism at a time, an answer wheel continually meshing with each of said driving mechanisms, a printing wheel rigidly connected with each of said answer wheels, each of said printing wheels having symbols thereon.

4. A cryptographic device formed with means for computing simultaneously the numerical values of one or more linear functions of a proposed sequence of numbers, the evaluation being effected with respect to a modulus, said means including a set of answer wheels, a driving mechanism for each of said answer wheels, a plurality of sets of actuating wheels, there being one actuating wheel for each driving mechanism in each set of actuating wheels, manually actuated means for moving said sets of actuating wheels into operative engagement with said driving mechanisms independently, whereby upon the rotation of said sets of actuating wheels said answer wheels will be moved through angles in direct proportion to the movement of said actuating wheels.

5. In a coding and decoding machine, a plurality of answer wheels, independent means for driving each of said answer wheels, a plurality of groups of actuating wheels, there being one actuating wheel in each group for each of said driving means, and a code wheel rigidly secured to each group of actuating wheels so that when the code wheel is actuated the actuating wheels associated therewith will function.

6. In a coding and decoding machine, a plurality of answer wheels, independent means for driving each of said answer wheels, a plurality of groups of actuating wheels, there being one actuating wheel in each group for each of said driving means, a code wheel rigidly secured to each group of actuating wheel, and means for preventing the rotation of the respective groups of actuating wheels until brought into interengagement with the driving means.

7. In a coding and decoding machine a plurality of toothed answer wheels, independent means for driving each of said answer wheels, a plurality of groups of actuating wheels, there being one actuating wheel in each group for each of said driving means, the wheels in each group having teeth, the number of which is a multiple of the teeth of said answer wheels, and a code wheel rigidly secured to each group of actuating wheels, said actuating wheels being capable of movement into and out of engagement with said driving means.

8. In a coding and decoding machine, a plurality of answer wheels, a driving mechanism for each answer wheel, a plurality of groups of actuating wheels, there being one actuating wheel in each group for each of said driving mechanisms, a code wheel secured to each group of actuating wheels, and means for throwing the respective groups of actuating wheels into and out of operation.

9. In a coding and decoding machine, a plurality of toothed answer wheels, independent means for driving each of said answer wheels, a plurality of groups of actuating wheels, there being one actuating wheel in each group for each of said driving means, a code wheel connected to each group of actuating wheels, means for normally locking said actuating wheels against operation, means for connecting each group of actuating wheels together and its code wheel, said last-mentioned means being movable in such a direction as to cause said actuating wheels to move into and out of engagement with said driving means, the wheels in each group of actuating wheels having teeth the number of which is a multiple of the teeth of said answer wheels.

10. In a coding and decoding machine, a plurality of toothed answer wheels, a plurality of groups of actuating wheels, there being one actuating wheel in each group for

each of said answer wheels, driving means for transmitting motion from said actuating wheels to said answer wheels, a code wheel secured to each group of actuating wheels, the actuating wheels in each group having teeth, the number of which is a multiple of the teeth of said answer wheel, and the arrangement of the wheels in each group being different from the arrangement in all the other groups.

11. In a cryptographic device, means capable of computing simultaneously the numerical values of one or more linear functions of a proposed sequence of numbers in respect to a modulus, said means including a series of rotatable indicating wheels, a driving mechanism for each of said wheels, and manually-operated means for causing said driving mechanisms to function, said manually-actuated means including a plurality of independent code wheels operatively connected to said driving mechanisms, said last-mentioned means being formed so that each indicating wheel may be rotated through a different angle when one of the code wheels has been rotated through a certain angle.

12. A device of the character described, comprising a plurality of rotatable indicating wheels having legends thereon, an independent driving mechanism connected to each of said indicating wheels, said driving mechanisms functioning to rotate each of said indicating wheels through the same angle when the driving mechanisms are moved to the same extent, a plurality of actuating wheels for each driving mechanism, said actuating wheels being movable into and out of operative engagement with said driving mechanisms, said actuating wheels being arranged in groups, each group moving as a unit independently, there being one actuating wheel in each group for each of said driving mechanisms, means for preventing rotation of any of said groups until the actuating wheels thereof are in operative engagement with said driving mechanisms, and a manually-actuated code wheel continually connected with each of said groups, whereby when said code wheels are rotated said actuating wheels will function.

13. A cryptographic device including a plurality of rotatable answer wheels, an independent driving mechanism for each of said answer wheels, rotatable toothed actuating wheels whose number of teeth and relative arrangements are determined by means of linear functions evaluated with respect to a modulus of which the number of teeth of the answer wheels are a multiple, and means for moving said actuating wheels into operative engagement with said driving mechanism.

14. A cryptographic device including a plurality of toothed answer wheels, each of said answer wheels, being provided with a

plurality of legends in the shape of symbols, operating means for rotating said answer wheels for grouping said symbols in sequence to secure a cipher or code legend, said operating means including an independent driving structure for each of said answer wheels, and actuating wheels for actuating said driving structures, said actuating wheels having their sizes determined in agreement with linear functions evaluated in respect to a modulus, said modulus being a number equal to or an exact divisor of the number of teeth on each of said answer wheels.

15. A cryptographic device including a plurality of indicating wheels, each indicating wheel being formed with a plurality of legends in the shape of numbers, means rotating said indicating wheel and therefore grouping said numbers in an order representing an answer, said means including a driving mechanism for rotating each indicating wheel independently, a plurality of groups of actuating means for coacting with said driving mechanism, a manually actuated means for moving independently each of said groups of actuating means into and out of operative engagement with said driving means.

LOUIS WEISNER.
LESTER S. HILL.

100

105

110

115

120

125

130