

Feb. 3, 1925.

1,525,065

J. M. BROWNING

AUTOMATIC FIREARM

Filed Dec. 15, 1923

6 Sheets-Sheet 1

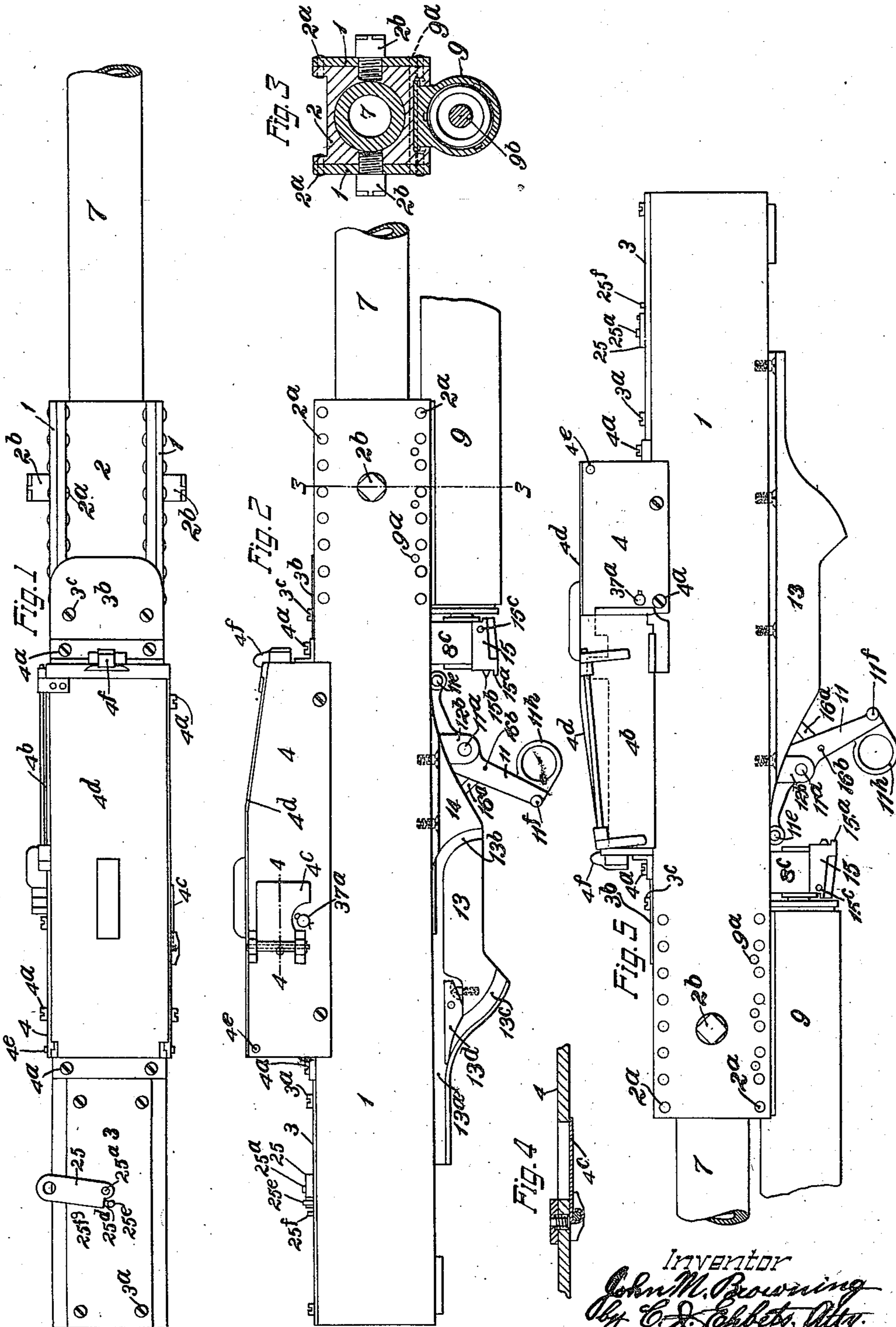

INVENTOR
J. M. Browning
 By *C. J. Roberts, Atty.*

Feb. 3, 1925.

1,525,065

J. M. BROWNING

AUTOMATIC FIREARM

Filed Dec. 15, 1923

6 Sheets-Sheet 2

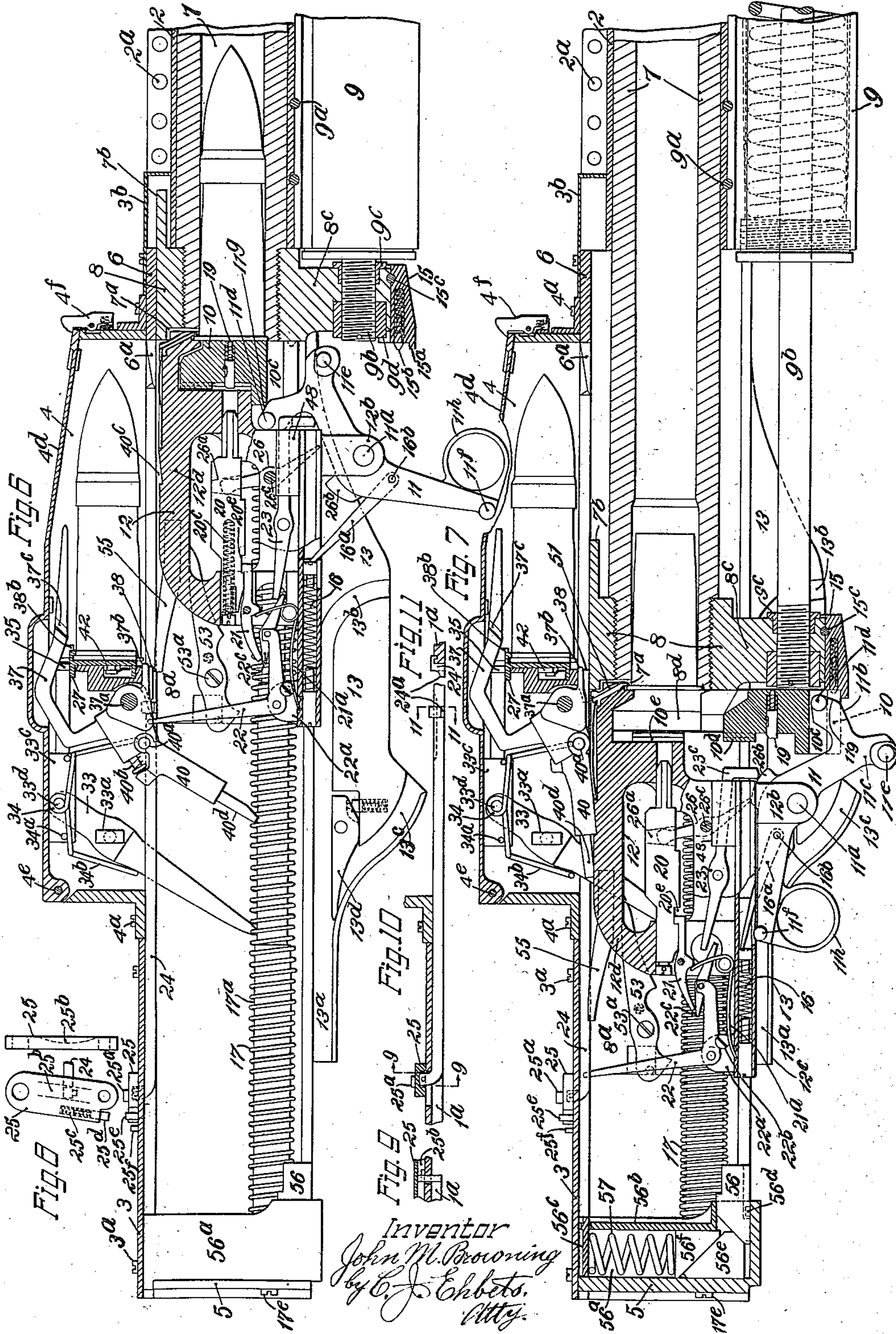

Inventor
 John M. Browning
 by C. J. Chabets,
 Atty.

Feb. 3, 1925.

1,525,065

J. M. BROWNING

AUTOMATIC FIREARM

Filed Dec. 15, 1923

6 Sheets-Sheet 3

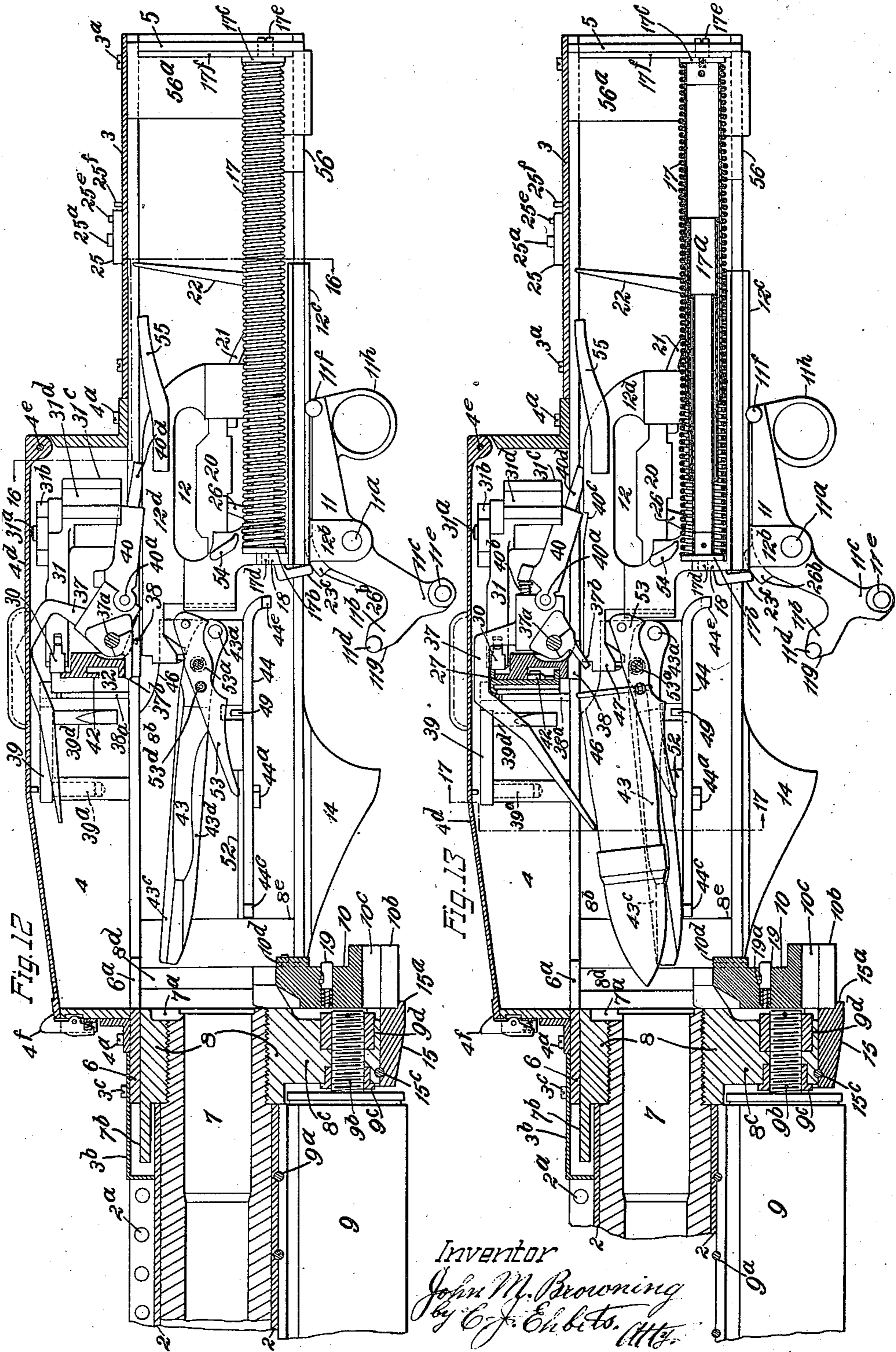

Inventor
John M. Browning
By C. J. Ehlers, Att.

Feb. 3, 1925.

1,525,065

J. M. BROWNING

AUTOMATIC FIREARM

Filed Dec. 15, 1923

6 Sheets-Sheet 4

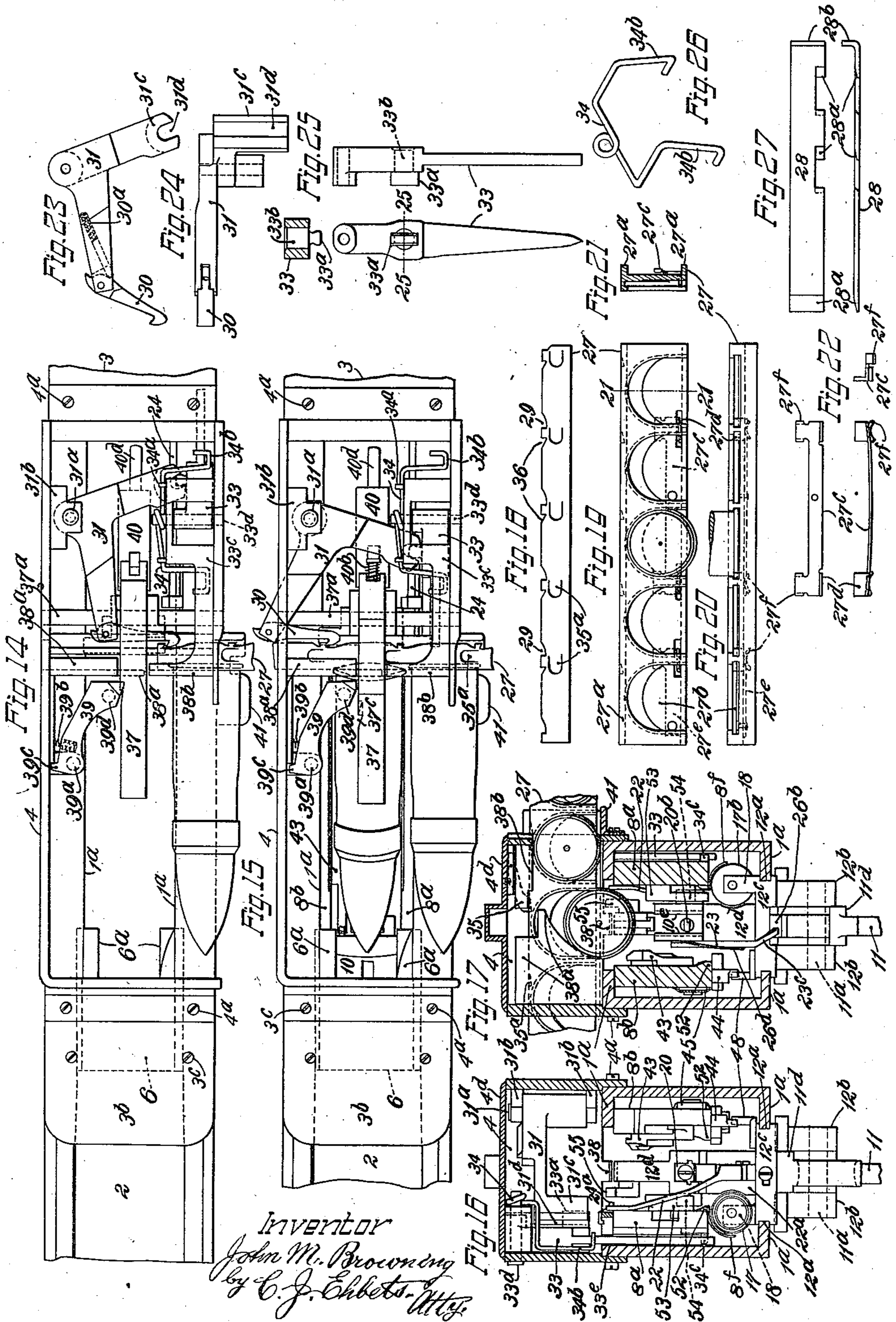

Inventor
 John M. Browning
 by C. J. Ehrets-Atty.

Feb. 3, 1925.

1,525,065

J. M. BROWNING

AUTOMATIC FIREARM

Filed Dec. 15, 1923

6 Sheets-Sheet 6

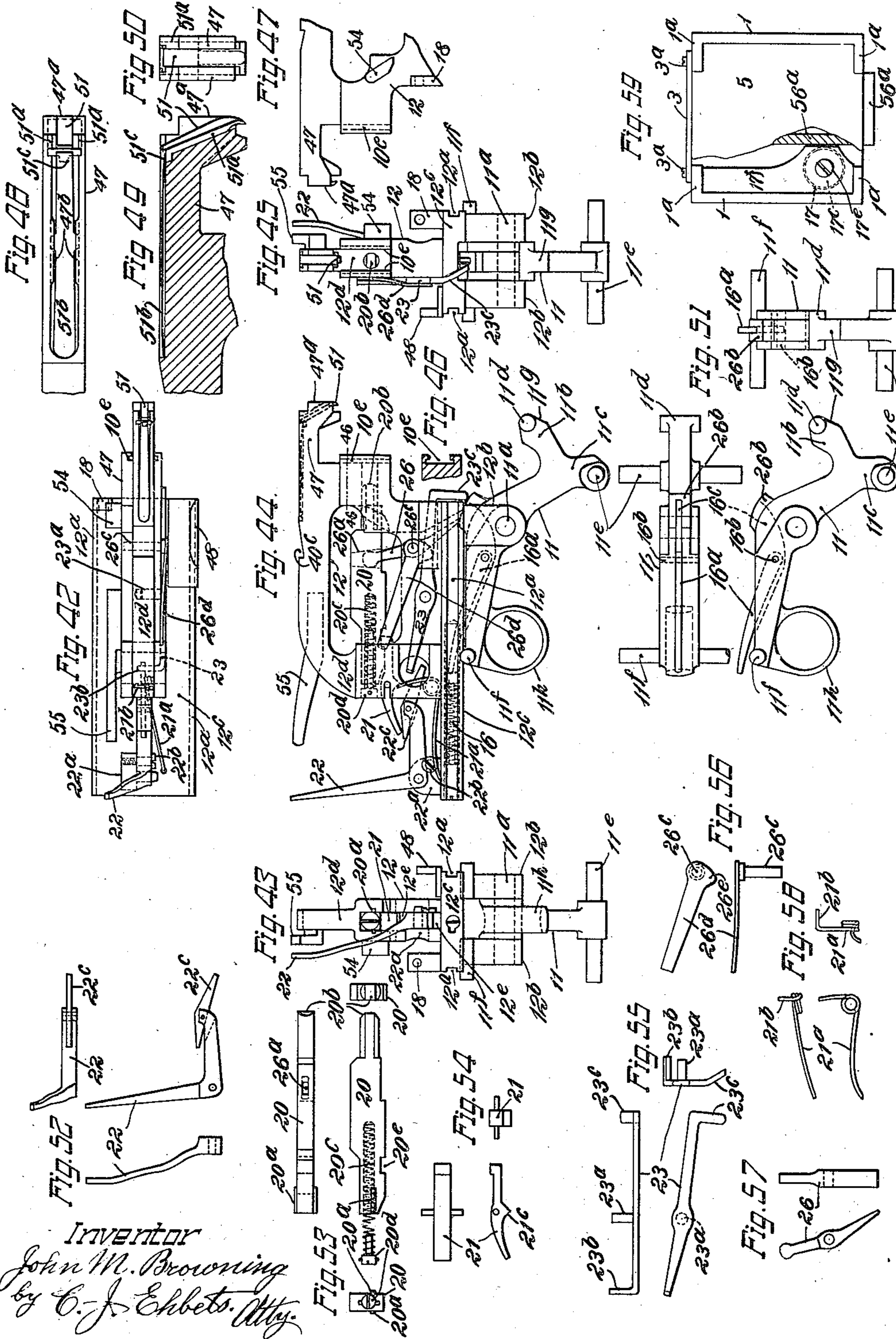

Inventor
John M. Browning
 by *C. J. Ebbets, Atty.*

UNITED STATES PATENT OFFICE.

JOHN M. BROWNING, OF OGDEN, UTAH.

AUTOMATIC FIREARM.

Application filed December 15, 1923. Serial No. 680,963.

To all whom it may concern:

Be it known that I, JOHN M. BROWNING, a citizen of the United States, residing in Ogden, in the county of Weber and State of Utah, have invented certain new and useful Improvements in Automatic Firearms, of which the following is a specification, reference being had to the accompanying drawings, forming a part hereof.

The invention relates to an automatic gun of the recoil-operated type in which all the operations of the mechanism, except that of the trigger, are automatically effected.

A main object of the invention is to provide an automatic gun of this character which is adapted to fire large caliber projectiles such as can be loaded with a high explosive charge (37 mm. or larger cartridge for instance) but so light in weight as to be mobile, adapted to be mounted on aircraft and fired from any position and yet most durable. This object is attained by providing a novel construction and combination of parts, including, amongst other things, new and novel means for holding and feeding the cartridges, a novel form of lock frame and co-operating parts and novel means for actuating the breech block to close and open the breech. Moreover, I have provided a construction so simple that the gun can be entirely taken apart and assembled quickly and without the use of any tools, so light that it can be easily carried or moved from place to place, and can be mounted on any airplane or aircraft of a usual type and can be fired in any position, and yet strong, reliable and safe in operation, and capable of withstanding the severe shocks and strains which accompany the firing of large caliber projectiles.

While a main object of my invention is to provide an automatic gun for firing large caliber projectiles, the invention is equally applicable to small caliber guns.

Other and further objects and advantages will appear from the following disclosure.

The inventions in their preferred form are shown in the drawings in which,

Fig. 1 represents a top plan view of the gun.

Fig. 2 represents a right hand side elevation of the gun.

Fig. 3 represents a vertical transverse section in the lines 3—3 of Fig. 2.

Fig. 4 represents a horizontal section of the dust cover and feed box in the line 4—4 of Fig. 2.

Fig. 5 represents a left hand side elevation of the gun.

Fig. 6 represents a right hand view of a central longitudinal vertical section showing the reciprocating parts in their forward position ready for firing. The barrel and recuperator are broken away, certain parts including the buffer are in elevation, and certain parts including the cocking lever pivot pin spring arm and the feed pawl lever, are not shown.

Fig. 7 represents a right hand view of a central longitudinal vertical section showing the reciprocating parts in a rearward position. The barrel and recuperator are broken away, certain parts are in elevation and certain parts including the cocking lever pivot pin spring arm and the feed pawl lever, are not shown.

Fig. 8 represents the trigger, detached, in top plan view and front view. In the top plan view a portion of the trigger bar is also shown.

Fig. 9 represents a front sectional view showing the top of the casing, the trigger bar and the trigger in the line 9—9 of Fig. 10.

Fig. 10 represents a right hand side elevation of the trigger bar with the trigger and portions of the casing and feed box in section.

Fig. 11 represents a front view of the trigger bar with a portion of the top flange of the left hand side plate in section, in line 11—11 of Fig. 10, showing the connection between the front end of the trigger bar and said flange.

Fig. 12 represents a left hand view of a central vertical longitudinal section, with the lock frame and other parts in elevation. This view shows the parts when the barrel is in its forward position and the lock frame is being held in its rearward position, ready for the insertion of cartridge into the gun.

Fig. 13 represents a left hand view of a vertical longitudinal section showing the parts shown in Fig. 12 in position to inject a cartridge into the breech of the barrel.

Fig. 14 represents a top plan view of the gun with the top cover of the feed box and its latch removed and the trunnion block

and casing broken away at front and rear. The parts are in the position which they occupy in Fig. 12 with the first cartridge being fed into the gun. The barrel extension and breech block are not shown.

Fig. 15 represents a top plan view of the gun with the top cover of the feed box and its latch removed and the trunnion block and casing broken away at front and rear. The parts are in the position which they occupy when a cartridge is about to be injected into the breech as shown in Figs. 13 and 17.

Fig. 16 represents a vertical transverse section in the line 16—16 of Fig. 12. In this figure the cartridge carrier is not shown.

Fig. 17 represents a vertical transverse section in the line 17—17 of Fig. 13, with a cartridge being cammed from its recess in the feed plate and the cartridge guide lever in its upper position; in Fig. 17 the cartridge carrier is omitted, and the cartridge is in an earlier stage of its progress from the feed plate to the breech than in Fig. 13.

Fig. 18 represents a plan view of the feed plate.

Fig. 19 represents a front view of the feed plate with one cartridge in locked position in the plate.

Fig. 20 represents a bottom view of the feed plate with one cartridge locked in position in the plate.

Fig. 21 represents a vertical transverse section of the feed plate in the line 21—21 of Fig. 19.

Fig. 22 represents a front view, bottom view and a right hand end view of the spring catch which locks the cartridges in the feed plate.

Fig. 23 represents a top view of the feed pawl lever and feed pawl.

Fig. 24 represents a left hand side view of the feed pawl lever and feed pawl.

Fig. 25 represents a front view, a right hand side view and a horizontal section of the feed lever in the line 25—25 of the right hand side view.

Fig. 26 represents a perspective view of the feed lever spring.

Fig. 27 represents a top view and a front view of the cartridge loading tool.

Fig. 28 represents a top view of the barrel (broken away) and the barrel extension and the parts carried thereby.

Fig. 29 represents a right hand side view of the barrel (broken away) and the barrel extension and the parts carried thereby.

Fig. 30 represents a rear view of Fig. 29, with the several parts in their respective positions.

Fig. 31 represents a front view of Fig. 29, with the several parts in their respective positions.

Fig. 32 represents on an enlarged scale a

section of the right hand arm of the barrel extension and parts carried thereby in the line 32—32 of Fig. 29.

Fig. 33 represents a top view and a right hand side view of the ejector.

Fig. 34 represents a top view and a right hand side view of the cartridge guide stop lever.

Fig. 35 represents a rear view of Fig. 36.

Fig. 36 represents a right hand side view of the right hand arm of the barrel extension showing, in dotted lines, the cartridge guide lever in its intermediate position.

Fig. 37 and Fig. 38 are the same, respectively, as Figs. 35 and 36, with the cartridge guide lever in its lowest position.

Fig. 39 represents top, rear and right hand side views of the breech block.

Fig. 40 represents top, rear and right hand side views of the breech block stop.

Fig. 41 represents top and right hand side views of the cartridge guide lever.

Figs. 42, 43, 44 and 45 represent respectively, top, rear, right hand side and front views of the lock frame, with its associated parts.

Fig. 46 represents a fragmentary horizontal section in the line 46—46 of Fig. 44.

Fig. 47 represents a left hand side view of the upper front portion of the lock frame and charger, showing the ejector stud.

Fig. 48 represents a top view of the charger, showing the extractor and extractor spring.

Fig. 49 represents a central vertical section of the front portion of the charger, with the extractor and extractor spring in elevation.

Fig. 50 represents a front view of the charger and extractor.

Fig. 51 represents top, right hand side and front views of the breech block actuating lever.

Fig. 52 represents a top view, a rear view and a right hand side view of the trigger lever and trigger lever connector.

Fig. 53 represents top, rear, right hand side and front views of the hammer.

Fig. 54 represents top, right hand side and front views of the sear.

Fig. 55 represents top, right hand side and front views of the trip lever.

Fig. 56 represents a right hand and a bottom view of the cocking lever pivot pin.

Fig. 57 represents a right hand side and a front view of the cocking lever.

Fig. 58 represents a top, a right hand side and a front view of the sear spring.

Fig. 59 represents a rear view of the gun with the rear plate broken away, showing the reaction spring and the shoulder on the guide rod (in dotted lines), the rear projection on the guide rod, the guide plate and a portion of the buffer housing.

The gun represented by the drawings

comprises a frame of breech casing 1, rectangular in form, and adapted to contain the breech and firing mechanism. The said casing is made up of two strong vertical side plates provided, except at their front end portions, with inturned flanges 1^a at top and bottom, as shown in Figs. 16 and 17. The casing is closed at the top and ends as hereinafter described.

10 A trunnion block 2 is located between the forward ends of the side plates, where the inturned flanges 1^a are omitted, and said block is firmly secured to the side plates at top and bottom, as by a plurality of transverse rivets 2^a. Rearwardly of said trunnion block the bottom of the casing is left open in the space between the lower inturned flanges of the side plates for the ejection of the empty shells and for other purposes as will hereinafter appear. Projecting laterally from the trunnion block are the usual trunnions 2^b for mounting the gun on a carriage or other supporting means.

25 The top of the casing is closed at the rear by the fixed top plate 3 rigidly secured to the inturned flanges at the top of the side plates, as by means of screws 3^a (Fig. 1). From the front end of the top plate 3 forward to a point a short distance back of the rear end of the trunnion block 2, the casing is closed at the top by the upwardly projecting feed box 4, secured on both sides to the side plates of the casing and at front and back to the top side plate flanges in any well known manner, as by screws 4^a. This feed box contains members of the cartridge feeding mechanism and is provided with a transverse feed channel into which the cartridges and the feed plate carrying the same may be fed from left to right into the gun, the feed plate being fed out at the right hand side as the firing proceeds. When the gun is not in use, this channel is closed by outwardly swinging doors to prevent the entrance of foreign matter, such as snow or dirt, the door 4^b on the left-hand side swinging upward and permitting the entrance of the cartridges and feed plate and the smaller door 4^c on the right hand side swinging back and permitting the exit of the feed plate. To permit access to the parts of the mechanism in the box 4, the top of the box is closed by a cover 4^d, hinged at the rear at 4^e and held in its closed portion at the front by a latch 4^f. The door 4^b is hinged to this cover so as to swing outwardly and upwardly. Spring plungers of a usual type (see Fig. 4) co-operate with the doors 4^b and 4^c to hold them either in their open or closed positions.

The top of the casing between the front end of the feed box 4 and the trunnion block 2 is closed by a small plate 3^b fas-

tened as by screws 3^c to the top flanges of the side plates, which top flanges run forward to this point. The front end of this plate projects downwardly and fits into the groove at the top of the trunnion block to keep out foreign matter (see Figs. 12 and 13). At the rear end, the breech casing 1 is closed by a vertically slidable rear plate 5 (Figs. 12 and 13) which is guided and held against longitudinal movement between the side plates by having ribs on its sides engaging corresponding grooves in the side plates. As shown, the rear plate 5 is slid upwardly into position and held therein by a guiding plate and rearward projection on the end of the reaction spring guide rod as hereinafter described.

Between the top side flanges of the side plates at their forward ends is the bridge plate 6 (Figs. 12, 13 and 14). This plate is rigidly attached to said side flanges as by rivets not shown, the side flanges being cut away on their under faces to receive the side portions, correspondingly cut away on their upper faces, of this plate whereby the same is flush with said flanges at top and bottom. This plate has rearwardly extending shoulders 6^a against which the breech block abuts on its upward movement and which limit said upward movement as hereinafter described. The inner upper edge of the left hand shoulder 6^a slopes downwardly and inwardly to accommodate the cartridge as it is fed into the gun as hereinafter described.

The barrel 7 is supported for longitudinal movement in a seat therefor in the trunnion block 2 and in order to minimize friction said seat is preferably slightly counterbored from its rear end so that the barrel slidably engages only the forward portion of said seat. At its rear end the barrel is firmly secured as by screw threads (Figs. 12, 13 and 29) to the barrel extension 8, which, near its forward end, is of a size and shape to slidingly fit the inside of the breech casing. The rearward extending arms 8^a and 8^b of the barrel extension are spaced from the side walls of the casing for the greater portion of their lengths, as shown clearly in Figs. 16, 17 and 28; they are also cut away at the bottom for the greater portion of their lengths for reasons which will become apparent as the description proceeds. Thus the combined barrel and barrel extension are supported and guided in their reciprocations at two spaced points only, thereby greatly lessening the friction between said parts and the breech casing.

To check the recoil of the heavy barrel and barrel extension and to return them to their forward firing position as soon as they have reached the limit of their recoil movement, a recuperator 9 is provided. This recuperator has the usual internal construc-

tion which is well known and therefore need not be further described. The recuperator is conveniently secured to the under side of the trunnion block 2, by forming T-shaped grooves on the bottom of the trunnion block adapted to receive corresponding T-shaped ribs on the top of the rear portion of the recuperator, and said members are rigidly secured against relative longitudinal movement by transverse pins 9^a (Figs. 2 and 3).

At the rear of the trunnion block the barrel extension is formed with a downwardly projecting lug 8^c having a longitudinal hole to receive the screw threaded rear end of the recuperator piston rod 9^b. Said hole is counterbored from each end, thereby forming shoulders adapted to be clamped between forward and rear nuts, 9^c and 9^d, respectively, (Fig. 6), each having cylindrical portions to fit the counterbores and locked against rotation when in their operative position, by the breech block stop as hereinafter described, or by any other suitable means. In this manner a very strong connection between the piston rod and the barrel extension is obtained, said connection permitting the easy disassembly of the parts by simply unscrewing the rear nut 9^d when the breech block stop has been removed.

The breech block 10 is formed as shown in Fig. 39, with vertical ribs 10^a on each side which have a sliding fit in vertical grooves or mortises 8^d in the barrel extension 8 (Figs. 12 and 28). At its lower rear end the breech block is widened longitudinally at 10^b (Fig. 39), this widened lower end having a T-shaped slot 10^c therein for a purpose hereinafter described. Rigidly attached to or integral with the rear face of the breech block, near its top, is the locking rib 10^d hereinafter more fully described. The breech block 10 is adapted to open and close the breech of the barrel by vertical reciprocation in the barrel extension, and is reciprocated for this purpose by the breech block actuating lever 11 in a manner now to be described.

Mounted for longitudinal reciprocation in the casing is the lock frame 12, shown detached in Figs. 42, 43, 44 and 45. At 12^a (Figs. 43 and 45) are longitudinal grooves on opposite sides of the horizontal portion 12^c of the lock frame to receive the inwardly projecting bottom flanges 1^a of the side plates of the casing 1 (see Figs. 16 and 17), and thereby guide and support the lock frame for longitudinal movement therein. As shown in Figs. 16 and 17 the upper portion of the lock frame takes its position and reciprocates between the arms 8^a and 8^b of the barrel extension. Depending from the bottom of the front end of the lock frame are two lugs 12^b (see Figs. 44 and 45)

in which the transverse breech block actuating lever pin 11^a is made fast. Pivotaly mounted between the lugs 12^b on the pin 11^a is the breech block actuating lever 11, of the form shown in Fig. 51. The forward arm of this lever ends in two diverging branches 11^b and 11^c. The end of upwardly projecting branch 11^b is formed with two short lateral studs 11^d of a size and form to enter the transverse opening of the T-slot 10^c of the breech block. When the studs 11^d are in the slot 10^c of the breech block, the rocking of the lever 11 on its pivot will cause the vertical reciprocation of the breech bolt. In Fig. 6 the parts are shown in full firing position, with the breech block in its raised position, closing the breech. When the cartridge is fired the barrel, barrel extension, breech block and lock frame recoil and during this recoil the lever 11 is rotated on its pivot, by means hereinafter described, causing the studs 11^d to enter the transverse opening in the slot 10^c of the breech block and move the breech block downwardly from the position shown in Fig. 6 to its lowered position shown in Fig. 7, when the barrel and barrel extension are substantially at the end of their rearward movement. The barrel and barrel extension now move forward again under the tension of the recuperator spring carrying with them the breech block, but the lock frame with its accompanying parts continues its recoil until stopped by the buffer, hereinafter described, and after a short forward movement it is temporarily held in a rearward position by means hereinafter described, the barrel, barrel extension and breech block and the lock frame and its accompanying parts thereby separating and permitting the ejection of the discharged cartridge and the feeding into place of a new cartridge. (See Figs. 12 and 13.) As the breech block moves forward with the barrel and barrel extension, leaving the lock frame in its rearward position, the studs 11^d will be withdrawn from the slot 10^c, leaving the parts as shown in Figs. 12 and 13. When subsequently the lock frame moves forward after the barrel has reached the limit of its forward movement and a new cartridge is in position to be inserted into the breech, the studs 11^d will again enter the slot 10^c, the lever 11 will be rotated on its pivot and the breech block will be moved vertically to its raised position shown in Fig. 6, closing the breech.

The rocking of the lever 11 during the longitudinal reciprocation of the lock frame is brought about by a plurality of cam surfaces on cam plates fastened to the bottom of the side plates co-operating with studs on the lower branch 11^c of the breech block actuating lever 11 and similar studs on the rear arm of said lever. Rigidly fastened

as by screws to the bottom inturned flange of the left hand side plate of the casing and depending therefrom is the cam plate 13 (see Figs. 2, 5 and 6). The bottom edge of this plate beginning at its front end first slopes rearwardly and downwardly, then runs for a distance substantially parallel with the bottom of the casing, then slopes rearwardly and downwardly again for a short distance, then slopes upwardly and rearwardly, and then runs parallel to, and a short distance below, the bottom of the casing.

At 13^a is a cam groove on the inner side of the cam plate; commencing at the rear this cam groove runs horizontally for the greater part of its length and ends in a downwardly and forwardly curving portion 13^b. The upper surface of the straight portion of this groove is the under surface of the bottom inturned flange of the left hand side plate. At 13^c is an upwardly and rearwardly inclined cam groove opening into the cam groove 13^a. The top of this groove 13^c is closed by a spring pressed switch 13^d (Fig. 6). Firmly attached to and depending from the bottom flange of the right hand side plate of the casing and just to the rear of the breech block when it is in its lowered position is the cam plate 14 (see Figs. 12 and 13) which is of the same size and shape as that portion of cam plate 13 forward of cam groove 13^b.

The cam surfaces and grooves just described cooperate with studs on the breech block lever 11 to rock said lever to raise and lower the breech block. The end of the lower branch 11^e of the forward arm of lever 11 is formed with two long lateral studs 11^e. The end of the rear arm of the lever 11 is formed with two long lateral studs 11^f. When the parts are in full firing position with the breech closed as shown in Fig. 6 the forward arm of the lever 11 is in a raised position with the studs 11^e in contact with the bottom flanges of the side plates of the casing forwardly of the front ends of the bottom edges of the cam plates 13 and 14, the studs 11^e being long enough to make this contact. As the parts, including the lock frame 12 and lever 11, move rearwardly on the recoil following the firing of a cartridge the contact between the studs 11^e and the rearwardly and downwardly sloping bottom edges or cam surfaces of the cam plates 13 and 14 will cam down the front arm of the lever 11, rocking the lever on its pivot. The initial movement of the lever carries the studs 11^a forwardly and downwardly into the slot 10^c of the breech block, and further movement of the lever 11 about its pivot carries the breech block vertically downward. Meanwhile the rear arm of the lever is swinging upwardly and before the studs 11^e leave the rearwardly

and downwardly sloping cam surfaces on the bottom of the cam plates 13 and 14 the left hand stud 11^f on the rear arm of lever 11 enters the upwardly and rearwardly inclined cam groove 13^c on the inside of plate 13 which acts on said stud 11^f to continue the swinging of lever 11 about its pivot on the further rearward movement of the parts, carrying the breech block to its lowest position, as shown in Fig. 7. As hereinafter described, the lock frame thereafter continues its rearward movement and the stud 11^f presses aside the switch 13^d (Fig. 6), and passes into the rear portion of cam groove 13^a (Fig. 7), permitting the switch to snap back and close the top of groove 13^c. When the stud 11^f passes into groove 13^a, the breech block will have reached its lowest position and the right hand stud 11^f will come into contact with the bottom inturned flange of the right hand side plate.

The rearward movement of the barrel and barrel extension is stopped by the recuperator before the lock frame has reached its limit of recoil and the recuperator returns the barrel and barrel extension to battery. The recoil and the forward movements of the barrel and barrel extension are buffered by the recuperator. On its forward movement the barrel is stopped by engagement of the front face of the barrel extension with the rear face of the trunnion block.

After the barrel has stopped its recoil the lock frame continues its recoil under its own momentum against the reaction spring, the barrel and lock frame drawing apart from each other, and any excess of recoil will be finally absorbed by a suitable buffer arranged on the rear plate of the casing and hereinafter described. The lock frame is held in a rear position as shown in Fig. 7 by means hereinafter described and the barrel, barrel extension and breech block return to their forward firing position under the action of the recuperator spring in the usual manner. Upon such separating movement of the barrel and its accompanying parts from the lock frame, the breech block and the breech block lever are disconnected (see Figs. 12 and 13), the studs 11^a having withdrawn rearwardly from the T-slot 10^c. While these members are so disconnected it is necessary to hold the breech block in its lowest position, so that on the subsequent return movement of the lock frame the studs 11^a will enter the T-slot 10^c of the breech block and raise the block to its breech closing position. To this end, a breech block stop 15 (see Figs. 6, 7, 12, 13 and 40) is secured to the lower end of the downwardly projecting portion 8^c of the barrel extension 8, said stop being provided with a rearwardly projecting shoulder 15^a on which the bottom of the breech block, when the same is in its lowest position, is adapted to rest. The breech

block is frictionally but firmly held in this position by a spring pressed plunger 15^b mounted in said stop and projecting into a recess 10^f on the front face of the breech block. I find this friction plunger adequate to hold the breech block in its lowered position under any unusual conditions, such as when the gun is fired upside down. The sides of said plunger are beveled and the sides of the recess in the breech block are correspondingly formed, thereby permitting the plunger to be automatically pressed aside by applying substantial force to the block to raise it. The breech block stop 15 is secured to the end of the portion 8^c of the barrel extension by a longitudinal rib and groove connection (see Fig. 31) and a transverse pin 15^c passing through said members to secure them against relative longitudinal movement. By removing the pin the stop can be rearwardly withdrawn and the breech block can then be downwardly removed from the barrel extension. By the means just described I make certain that the breech block will not move from its lowest position except when actuated by its actuating lever 11, even though the gun be fired upside down as in an aeroplane. This stop 15 may also prevent turning of the nuts 9^c and 9^d, which may be square-headed for this purpose, thereby locking said nuts until stop 15 is removed.

On the return of the barrel, barrel extension and breech block to forward position, if any cartridges remain in the feed plate, the lock frame will be automatically released and under the tension of the reaction spring will be returned to its forward position, pushing a fresh cartridge into the barrel chamber, all of which will be hereinafter more fully described. During the forward movement of the lock frame the left hand stud 11^f on the rear arm of the breech block actuating lever 11 will first be guided in the horizontal cam groove 13^a of the cam plate 13, the switch 13^d now closing the entrance to cam groove 13^c. When the stud 11^f reaches the downwardly and forwardly curved cam groove 13^b, the studs 11^d at the forward end of lever 11 will have entered the slot 10^e in the breech block and the cartridge will have been almost fully inserted into the chamber, and as the lock frame completes its forward movement the studs 11^f will be guided downwardly by the cam groove 13^b, and the rear cam surface on the cam plate 14 which at their lower ends are substantially vertical, rocking the lever 11 about its pivot to raise the front arm of the lever and thereby raise the breech bolt at a rapidly increasing rate. The passage of the studs 11^f through cam groove 13^b and along said cam surface serves to raise the breech block about half way of its full upward movement while the lock frame is

completing its forward movement and pushing the cartridge into the barrel. The studs 11^f leave the cam groove 13^b and the rear cam surface on cam plate 14 just as the lock frame completes its forward movement and the final upward movement of the breech block to its upper closing position is completed partly under its own momentum and partly by the continued rotation of the lever 11 about its pivot by the action of the breech block lever spring 16 on the breech block lever strut 16^a.

The said breech block lever spring is seated in a longitudinal seat provided therefor centrally of the under side of the lower horizontal portion 12^c (Figs. 16, 42, 43 and 44) of the lock frame. Said spring abuts at its rear end against a collar on the end of a spring guide pin, and at its front end against another circular collar which, when the parts are assembled, abuts against the rear end of the lever strut 16^a. There are inturned flanges at the front end of the spring seat to hold the spring in its seat in case the strut is removed. The rear collar has a slot in its rear face allowing it to be turned on its axis, and forward of its rear face has a laterally projecting stud. The spring is inserted into its seat from the rear, and the rear collar may be pushed in against the tension of the spring, the stud passing through a groove cut therefor on the side of the rear portion of the spring seat, until the rear face of the rear collar is flush with the rear face of the portion 12^c of the lock frame, when by a partial rotation of the collar the stud will engage in a recess cut therefor in the bottom face of the lock frame, locking the spring in its seat. The front face of the front collar is recessed forming a seat for the rear end of the breech block lever strut 16^a which is pivoted at 16^b (Figs. 6 and 7) in a longitudinal groove 16^c cut in the top face of the rear arm of the breech block lever (see Fig. 51). When the breech block lever is rotated to lower the breech block, the strut 16^b will compress its spring 16 and for this purpose a slot is cut in the front portion of the bottom face of the spring seat. Fig. 44 shows the strut and spring when the rear arm of the breech block lever has been raised to its upper position. The strut 16^a has now passed dead center position and will serve to hold the breech block lever in the position shown. When the breech block lever is rotated in the opposite direction to raise the breech block, the rotation is first effected as above described by the engagement of the studs 11^f in the cam groove 13^b and rear cam surface on cam plate 14. Before said studs leave said cam groove and cam surface the strut 16^a has passed dead center position and the pressure of the spring is transmitted to the breech block lever by said strut and the rotation

thereof completed, which together with the momentum already acquired by the breech block raises the breech block to its uppermost position. When the breech block lever has reached the limit of its rotation in this direction by the engagement of the studs 11^e with the bottom faces of the lower flanges of the side plates of the breech casing as shown in Fig. 6, the pressure of the spring against the strut will serve to hold the breech block lever in the position there shown. The spring and strut therefore serve to hold the breech block lever in position after rotation in either direction.

The parts are so organized that there is a lost motion connection between the breech block and its actuating lever when the breech block has reached the limit of its upward movement. When the breech block stops in its uppermost position, the actuating lever continues to rotate until it is stopped by engagement of studs 11^e with the bottom faces of the lower inturned flanges of the side plates. In this further slight rotation of the breech block actuating lever 11, the studs 11^a pass rearwardly from the T-slot 10^c in the breech block and the then downwardly and forwardly sloping surface 11^e (Figs. 6, 12, 13 and 51) at the forward end of the arm 11^b engages the rear edge of the top of the T-slot holding the breech block firmly in place, as shown in Fig. 6.

Although the pressure of the breech block lever spring 16 prevents any substantial rebound of the actuating lever, such rebound might occur and if it does, the lost motion connection just described prevents such rebound from moving the breech block from its uppermost position which might cause a misfire. Furthermore, as hereinafter described, the hammer is retracted and cocked by the movement of the actuating lever on the recoil and the lost motion connection permits an initial retraction of the hammer before any downward movement of the breech block. Thereby the hammer and firing pin are freed from contact with each other and the forward end of the firing pin is freed from contact with the shell and the breech block is free to be lowered without any friction from the hammer or firing pin or injury to said firing pin. Again this lost motion connection offers a convenient means for permitting the parts to recoil a short distance before there is any movement of the breech block. The breech block is under tremendous pressure from the expansion of gases at the moment of firing and if, on the initial recoil of the parts the breech block was moved downwardly, it would resist movement to such an extent as to cause a severe strain on the operating parts. With the lost motion connection there is a sufficient initial recoil before the breech block is engaged for downward movement by the

studs on the breech block lever to permit the shell or projectile to leave the barrel and relieve the pressure on the breech block. If there were no lost motion connection, however, this same result could be secured by so organizing the engagement of the forward parts of the cams 13 and 14 with studs 11^e that the lever 11 would not commence to rotate until after the initial recoil of the parts.

The upward movement of the breech block is limited by the top of the breech block coming in contact with shoulders 6^a (Figs. 14 and 15) of the bridge plate 6.

Suitable means are provided to lock together the lock frame and the breech block when the lock frame is in its forward position and the breech block is in its upper closing position. Such locking means may comprise a vertical rearwardly projecting T-shaped rib 10^d arranged centrally and near the top of the rear face of the breech block 10 and adapted, when the breech block is in its raised position, to engage in a corresponding shaped groove 10^e (Figs. 44 and 46) on the front face of the lock frame. On the final upward movement of the breech block, immediately on the lock frame reaching its final forward position, the T-rib 10^d engages in the groove 10^e in the front face of the lock frame, locking the parts firmly together at the moment of firing. This prevents the lock frame from rebounding after it has reached its forward position and insures that the parts will be in firm engagement at the moment of firing and on their initial recoil. It also insures that the lock frame can not be retracted manually without lowering the breech block.

For the manual operation of the breech mechanism the breech block actuating lever 11 is provided with a finger piece 11^b which depends from the rear portion of the rear arm of said lever (Figs. 44 and 51) and which is adapted to be engaged by the hand of the operator. A rearward pull on the finger piece when the parts are in the forward position shown in Fig. 6 acts to first swing the actuating lever 11 about its pivot, the initial pull seating the studs 11^a in the slot 10^c in the breech block and the continued pull rotating the lever 11 and lowering the breech block vertically. Since the pull required to retract the lock frame is insufficient to move the heavy barrel against the recuperator spring, the barrel and its accompanying parts are not moved rearwardly on manual retraction of the lock frame. But since the breech block and lock frame are locked together when in firing position, the lock frame can not be disengaged from the breech block until the block has been lowered, thereby insuring that the initial pull on the breech block

actuating lever will move the breech block downward and insuring that the lock frame will not be retracted without lowering the breech block.

5 As explained above, the initial pull on the finger piece 11^h seats the studs 11^a in the slot 10^c of the breech block and starts the breech block downward without separating the lock frame from the breech
10 block. Just as the breech block reaches the position where it becomes unlocked from the lock frame the left hand stud 11^f at the rear of the lever 11 enters the cam groove 13^b, the lock frame up to this time being
15 held in its forward position by its locking engagement with the breech block. On continued pull on the finger piece the stud 11^f passes rearwardly and upwardly, guided by cam groove 13^b, moving the lock frame rear-
20 wardly and swinging the lever 11 about its pivot to fully lower the breech block. As the breech block reaches its fully lowered position the stud 11^f passes into the horizontal cam groove 13^a, and on continued
25 pull on the finger piece the said stud will follow this cam groove, the studs 11^a on the forward arm of lever 11 being withdrawn from the slot 10^c in the breech block and the entire lock frame being moved rear-
30 ward against the pressure of its reaction spring. On manually returning the parts to forward position, the members go through the same cycle of operations and movements as in the automatic operation.
35 It will be seen that in the manual operation, since the barrel remains forward, the rearwardly and downwardly inclined bottom cam edges of cam plates 13 and 14, as well as the cam groove 13^c, perform no func-
40 tion, their normal function of moving the breech block to its lower position being performed manually and by the cooperation of the cam groove 13^b with the stud 11^f which insures that the breech block is moved to
45 the limit of its lowered position on the manual retraction of the lock frame.

By this construction and arrangements of parts, it is evident that the breech of the barrel can be manually opened and the lock
50 frame brought into a rearward position, ready to push a cartridge into the barrel chamber on the succeeding forward movement, in a minimum of time and with a single operation, namely, a rearward pull
55 on the finger piece 11^h of the breech block actuating lever 11.

The forward movement of the lock frame is slowed down and buffered by the cam operations on the breech block lever above
60 described and by its energy being transferred to the breech block and cartridge. The form of these cam surfaces and the weight of the breech block, which is raised to breech closing position during this for-

ward movement of the lock frame offer a
65 powerful retarding action on the movement of the lock frame and bring it to rest without any violent blow. The lock frame comes to a full stop by the front face of the
70 lower horizontal portion 12^c coming in contact with the rearwardly facing shoulders 8^e on the barrel extension (Figs. 12, 13, 28 and 29).

The reaction spring 17 is provided with a telescopic guide rod 17^a (Fig. 13), the
75 forward section of which is provided with a removable collared plug 17^b to receive the thrust of the front end of the spring, while the rear section of the said rod is formed with a similar collared plug 17^c providing
80 a shoulder (Figs. 12 and 13) to take the thrust of the rear end of said spring. By this construction the combined spring and its guide rod can be readily removed as a
85 unit from the casing. A small central projection 17^d providing a shoulder (Figs. 12 and 13) on the front end of the front section of the guide rod extends through and forwardly of said
90 washer and normally projects into a hole formed in an upwardly projecting arm 18 at the forward left-hand side of the lock frame (see Figs. 12, 16, 17, 43 and 45), while the rear section of the guide rod is
95 similarly formed with a rearward projection 17^e which engages a hole in the rear plate 5 (Fig. 12), to hold the guide rod in position laterally. To hold the rear plate firmly in its closed position, and to assist
100 in holding the guide rod in position and to facilitate assembly of the parts, the rear end of the guide rod 17^a is provided with a guiding or locating plate 17^f (Figs. 12, 13 and 59) positioned between plug 17^c and the rear
105 end of projection 17^e and adapted, when the rod is in position in the casing, to rest against the inner face of the left hand side of the rear plate and to engage the inner face of the left hand side plate of the casing and the upper and lower inturned
110 flanges of said side plate as shown in Fig. 59. When the projection 17^e therefore engages in the hole in the rear plate, the rear plate cannot be slid downwardly out of
115 position because of the engagement of the bottom edge of the guide plate 17^f with the bottom inturned flange of the left hand side plate. The forward end of the spring 17 is further guided and seated in a seat
120 formed therefor by the top surface of the lower horizontal portion 12^c of the lock frame 12, the lower left hand face of the centrally arranged upwardly projecting portion 12^d (Figs. 12, 13, 16 and 17) of said
125 lock frame and the arcuate guide 8^f on the bottom of the left hand arm 8^a of the barrel extension (see Figs. 16, 17 and 30). To disassemble the rear plate 5 and the com-

bined reaction spring, guide rod and guide plate, it is only necessary to press against the rear projection 17^e on the guide rod and move it forwardly beyond the front face of the rear plate by the point of a cartridge, and at the same time slide the rear plate downwardly to move the hole out of registry with the projection 17^e. When this is done the rear plate can be slid downwardly and completely withdrawn from the casing, and the combined spring, guide rod and guide plate can be rearwardly removed.

The firing pin 19 (Fig. 39) is mounted for longitudinal movement in a seat arranged centrally of the breech block in position to strike the center of the primer of a cartridge in the barrel chamber when the breech block is in its topmost position. The pin is held normally in its rear position with the firing point withdrawn into the breech block and its rear end protruding from the rear face of said breech block under the action of its spring and its longitudinal movement is limited in a usual manner by a transverse pin 19^a passing through a longitudinal recess formed in the cylindrical body of said pin (see Figs. 13 and 39).

The hammer 20 (Fig. 53) for cooperation with said firing pin is mounted for longitudinal sliding movement in a seat provided therefor in the central upwardly projecting portion 12^d of the lock frame 12 (see Figs. 6, 43 and 44). At their rear portions the hammer and hammer seat are substantially rectangular in cross section, the hammer seat having at its rear end a seat for the head of the guide pin as hereinafter described. The hammer is guided in its seat at the rear by ribs 20^a (Fig. 53) projecting from each side which engage corresponding grooves in the hammer seat and at their forward ends the hammer and its seat are cylindrical and the hammer has a sliding fit in its seat. At its forward end the hammer terminates in a flat nose 20^b (Fig. 53), to strike the firing pin. The main spring 20^c is seated in a cylindrical seat drilled in the hammer as shown in Fig. 53, abutting at its forward end against the end of the seat and at its rear end against the shoulder of the short guide rod 20^d (Fig. 53), which for this purpose is of a larger diameter at its rear than at its forward portion in the spring. The rear enlarged head of the guide rod has a slot, allowing the rod to be turned on its axis, and also carries two small lugs which project from opposite sides. The rear end of the hammer seat, which is cylindrical, is provided with a horizontal slot through which these lugs may be made to enter. Slightly in front of the rear end of the hammer two partly-circular recesses are cut into the wall of the seat

which the lugs of the guide rod may be made to enter by the rotation of the rod, locking the guide rod, spring and hammer in the hammer seat. This is a well known and usual construction and need not be further described. The recess 20^e (Fig. 53) is cut in the bottom face of the hammer forming a cocking notch to co-operate with the sear to hold the hammer cocked.

The hammer is held rearwardly in its cocked position against the tension of the mainspring by the sear 21, also carried by the lock frame 12. The form of the sear is shown in Fig. 54, and as there shown, it has two lugs, projecting from each side centrally of the sear, a downwardly inclined rear arm and a nose forming a shoulder at the top of the front end. Under the lugs is a downwardly and forwardly inclined surface 21^c to co-operate with the sear spring, as hereinafter described.

Immediately under the hammer seat the rear centrally and upwardly projecting portion 12^d of the lock frame has a longitudinal recess 12^e (Fig. 43). Cut longitudinally into the rear faces of the sides of this recess, just below the hammer seat is a slot, which slot makes a seat for the two lateral lugs rigid with said sear, pivoting the sear within the recess, with its downwardly inclined rear arm projecting rearwardly of said portion 12^d of the lock frame and its front arm projecting forwardly under the hammer (Fig. 44). The sear is normally held in its cocking position as shown in Figs. 6, 7 and 44, with the nose at its front end in engagement with the bottom of the hammer, by the sear spring 21^a (Figs. 6, 7 and 58). The sear spring is an ordinary wire spring, the rear end of which is seated in a shallow recess on the right hand top surface of the laterally widened portion 12^c of the lock frame, as shown in Figs. 6, 7 and 42. The upwardly projecting forward arm of the spring is bent at right angles at the top, forming a horizontally disposed arm 21^b (Fig. 56) which engages the forwardly and downwardly inclined under surface 21^c of the sear 21 (see Figs. 6, 7, 44 and 54), pressing it forwardly, thereby serving to keep the sear in its seat and yieldingly in its operative position.

The rear downwardly inclined arm of the sear is adapted to co-operate with the trigger lever 22, shown detached in Fig. 52, which is of bell-crank shape and pivoted on a fixed pivot stud projecting laterally from the right hand side of the lug 22^a which projects upwardly from the rear end of the horizontal portion 12^c of the lock frame just left of center (see Figs. 42, 43 and 44). The lever 22 is normally held on its pivot stud by the head of screw 22^b (Fig. 44). One arm of the trigger lever projects for-

wardly under the rear arm of the sear, while the other arm projects substantially vertically to a point adjacent the inner edge of the inwardly projecting top flange of the left hand side plate of the casing (Fig. 17).

To insure that the sear will not be tripped and disengaged from the cocking shoulder on the hammer, until the breech block is in its full upper locked position, the forward arm of the trigger lever 22 does not directly engage the rear arm of the sear, but has pivoted to it, at its forward end, a two-armed trigger lever connector 22^c (see Fig. 52) the rear arm of which is adapted to engage the sear, while the forward arm is adapted to co-operate with a trip lever 23 (Fig. 55). Centrally of the trip lever is a laterally inwardly projecting pivot pin 23^a, which is pivotally mounted in a corresponding hole in the right hand side of the lock frame. At its rear end the trip lever is formed with a laterally and inwardly projecting arm 23^b (Figs. 42 and 55), adapted to overlie the forward arm of the trigger lever connector 22^c, while its forward end projects beyond the front face of the lock frame and is there formed with an inwardly and downwardly extending projection 23^c, which extends into the path of the top surface of the forward arm of the breech block actuating lever 11. When the breech block actuating lever rotates and moves the breech block to its uppermost closing position, the top surface of the forward arm of said actuating lever engages said projection 23^c, raises it and thereby lowers the rear arm of said trip lever. The two positions are shown in Figs. 6 and 7. With the parts in the position shown in Fig. 6, when the trigger lever 22 is actuated by pulling it rearward, its forwardly extending arm is raised, the forward arm of the connector 22^c engages the arm 23^b of the trip lever and is held thereby while the rear arm of the said connector engages the rear arm of the sear; further movement of the trigger lever will now raise the rear arm of the sear and actuate the sear to release the hammer. When the parts are in the position shown in Fig. 7, with the breech block in its lowered position, and the rear arm of the trip lever 23 raised the normal movement given the trigger lever 22 is not sufficient to engage the front arm of the connector 22^c with the rear arm 23^b of the trip lever to trip the sear and release the hammer.

The trip lever being actuated by the breech block actuating lever 11 as it ends its rotation to raise the breech block, it is evident that the gun can not be fired until the breech block is in its uppermost position, the breech block lever thereby serving both to raise the breech block and to control the time of firing.

The trigger lever 22 projects at its upper end into the path of a lateral inwardly projecting lug 24^a at the forward end of the trigger bar 24 (Figs. 10, 11 and 16). The trigger bar, at its front end, is slidably secured to the top flange of the left hand side plate of the casing, as by a tongue and groove connection as shown in Fig. 10. At its rear end said trigger bar has an upward extension projecting through a longitudinal slot in the top plate 3, and provided with a lateral stud sliding on the top surface of said top plate to hold the rear end of said trigger bar from dropping down (Fig. 9). The trigger 25 (Fig. 8) is pivoted on the top of the top plate 3 by its pivot stud 25^a (Fig. 1) with its free end extending laterally beyond the left hand side plate of the casing. In the bottom face of the trigger is a slot 25^b (Fig. 8) into which the top of the upwardly projecting rear end of the trigger bar extends, so that when the free end of the trigger is swung rearwardly about its pivot stud the trigger bar will be moved rearwardly and will engage the trigger lever by its lug 24^a, thereby rocking the trigger lever and actuating the sear, if the parts are in their firing position as shown in Fig. 6.

A trigger spring 25^c (Fig. 8) is housed in a longitudinal recess at the pivoted end of said trigger, said spring acting through a plunger 25^d, whose inner end is also guided in said recess, against a fixed stud 25^e (Figs. 1 and 6) projecting from the top plate of the casing. The tension of this said spring acts to normally maintain the trigger and trigger bar in their forward positions, the forward movement of these parts being limited by the engagement of the upwardly projecting rear end of the trigger bar with the front end of the longitudinal opening in the top plate through which said rear end of the trigger bar projects (Fig. 10). The outer end of the plunger 25^d projects into a recess on the stud 25^e and this serves to maintain the trigger in position on its pivot stud 25^a. Also projecting upwardly from the top casing is the stud 25^f (Figs. 1 and 6) positioned to limit the rearward swing of the trigger so that the trigger lever can not be rocked sufficiently to actuate the sear unless the front end of the trip lever has been raised by the breech block actuating lever and the parts are in the position shown in Fig. 6. The trigger can be actuated by the direct engagement of the shooter's hand with its knurled free end, or by a lanyard or other means attached near its free end, or otherwise.

From the foregoing description of the arrangement of the parts of the firing mechanism on three relatively movable parts of the gun, namely, the vertically movable breech block, the longitudinally movable lock frame

and the fixed casing, it will be evident that a number of safety factors are introduced which prevent firing until and unless the breech block is at its uppermost breech closing position and the lock frame is in its foremost position and the parts are locked in full firing position.

In this connection it is to be noted that the lost motion connection between the breech block and its actuating lever, when the breech block is in its uppermost position, provides against the possibility of a misfire if the actuating lever should rebound when the lateral studs 11^e at the end of the upward stroke of the forward arm of said lever strike the bottom of the side plates of the breech casing. If such lost motion were not provided, it might happen that the rebound of the actuating lever would lower the breech block sufficiently so that the hammer would fail to transmit its full blow to the firing pin because out of line therewith; or the firing pin might fail to strike the center of the primer. Either of these results might cause a misfire.

The cocking of the hammer 20 is automatically effected during the rearward movement of the lock frame. For this purpose the hammer is provided just forward of its center, with a vertical slot 26^a (Figs. 44 and 53) of gradually increasing width from top to bottom of the hammer. Into this slot projects the upper arm of the cocking lever 26 (Fig. 57) which is pivotally mounted in a vertical slot in the forward part of the lock frame, opening downwardly into the space between the lugs 12^b which support the breech block actuating lever. The lower arm of said cocking lever projects into said space where it is in position, when the hammer is in its forward position, to be actuated by the front face of shoulder 26^b (Fig. 51) formed on the top face of said actuating lever, whereby when said actuating lever is swung about its pivot to lower the breech block after a cartridge has been fired, or when the lock frame is manually pulled to its rearward position, the lower arm of the cocking lever is moved forward and the upper arm of the same is moved rearward (Fig. 7), the engagement of the top of said upper arm with the rear face of the slot 26^a forcing the hammer rearwardly in its seat against the tension of the main-spring until it is cocked by the engagement of the sear in the cocking recess 20^e on the bottom face of the hammer. When the parts are in a rearward position, as shown in Fig. 7, the lower end of the cocking lever is resting on the top rounded surface of the shoulder 26^b, so that when the parts return to forward position and the actuating lever swings on its pivot to raise the breech block the lower end of the cocking lever will ride over the shoulder 26^b, which will pass from

engagement therewith, and when the hammer has been released the cocking lever will be rotated on its pivot so that the lower end thereof will be returned to a position rearwardly of that shown in Fig. 6 (where the hammer has not been released) and projecting into the path of the shoulder 26^b so that it will be actuated by the front face of said shoulder to again cock the hammer on the recoil of the lock frame.

The cocking lever is pivoted on the pivot pin 26^c (Fig. 56) which has a rearwardly projecting spring arm 26^d, the rear end of which is adapted to be seated in an arcuate groove at the right hand forward portion of the rearward and upwardly extending portion 12^d of the lock frame (Fig. 44). By springing or snapping the end of arm 26^d into the arcuate groove, the pivot 26^c is held firmly but removably in place and the cocking lever can be readily disassembled. The downwardly projecting lip portion 26^e (Fig. 56) of the spring arm engages the forward portion of the trip lever 23 and retains it in place (see Fig. 44).

The movable members of the firing mechanism hereinbefore described as mounted in the lock frame are conveniently arranged so as to permit their ready assembly or disassembly from said frame. By lifting the rear end of the sear spring 21^a from its recess, the spring can be readily removed from the frame. The sear will then be free to be rearwardly withdrawn, its trunions being withdrawn rearwardly from their seat. After withdrawal of the sear, the trigger lever can be swung about its pivot stud beyond the normal limit of its movement and laterally removed from its pivot stud on which it is normally held by the head of screw 22^b. By swinging or snapping the end of the spring arm 26^d from engagement in its groove in the lock frame this arm and the pivot 26^c can be laterally withdrawn and the trip lever will be made free to be withdrawn. The hammer can now be withdrawn. By turning the head of the guide rod 20^d a partial revolution the lugs thereon will become disengaged and the guide rod and spring can be withdrawn rearwardly. The hammer can then be withdrawn rearwardly from its seat in the lock frame and the cocking lever withdrawn from its slot.

When it is desired to fire automatically, the trigger is held back and on each forward movement of the lock frame the top of the trigger lever 22 engages with the stud 24^a on the trigger bar, raising the pivot of the trigger lever connector 22^c slightly higher than the position shown in Fig. 6. The forward arm of the breech block actuating lever 11 at the end of its breech block raising movement engages the inward and downward projection on the forward end 23^c of the trip lever 23, raising said forward

arm and depressing the rear arm, which actuates the front arm of the trigger lever connector (which is held in actuating position by the trigger and trigger lever) to actuate the sear to release the hammer. The hammer will therefore be released automatically, so long as there are cartridges in the gun, just as the breech block and lock frame come to full firing position on each forward return of the parts.

The cartridges are fed transversely, from left to right, to the vertical central longitudinal plane of the gun. My invention comprises novel means for holding a plurality of cartridges and for automatically feeding them into firing position in the gun. To this end I provide a cartridge holder or feeder, such as the feed plate 27 (Figs. 18, 19, 20 and 21) which comprises a substantially flat piece of metal or metal alloy (aluminum may be used to advantage) provided with longitudinal flanges 27^a (Fig. 21) at top and bottom, which extend rearwardly when the feed plate is in position in the transverse channel adapted to receive it. The front face of the feed plate is provided with seats such as the recesses 27^b to receive the heads of cartridges, these recesses, as herein shown being open at the bottom and rounded at the top to conform to the curvature of the cartridge case as shown in Fig. 19. Said recesses are formed at their edges with overhanging flanges adapted to receive the projecting annular rims of the cartridge heads. A cartridge is shown seated in the center recess in Figs. 19 and 20. It will be noted (see Figs. 19 and 21) that the bottom portions of recesses 27^b are cut deeper than the top portions and formed with a rounded wall. This is to make easy the withdrawal of the cartridges as hereinafter described, by permitting some play between the cartridge and the feed plate as the cartridge is withdrawn downwardly therefrom.

From the foregoing description it will be apparent when a cartridge head is inserted from the open end of a recess until it engages the rounded upper or inner end of said recess, it will be firmly held from longitudinal displacement with its axis substantially at right angles to the plane of the feed plate. To prevent the cartridges from dropping down out of the plate, means are provided for engaging the rims of said cartridge heads on the sides facing the open sides of the recesses. Said means may comprise a flat spring catch securely fastened to the lower portion of the rear face of the feed plate in such manner that its free and or ends will have a spring action relative to the rear face of the plate. 27^c, (Fig. 22), is such a catch adapted to be fastened at its center, as by a rivet as shown, giving two free ends. At each free end the catch

27^c is formed with a forwardly projecting stop projection 27^d, adapted to extend through a slot formed in the body of the plate, just below the point of tangency of the cartridge rim and the side of the recess, thereby projecting into the path of the cartridge and holding it from dropping down until the end of the catch is raised and the stop projection 27^b withdrawn rearwardly from its slot. The catch may be as shown at 27^e (Figs. 19 and 20) riveted to the plate at one end, and having only one free end bearing a stop projection. In the embodiment of the invention illustrated in which the plate is adapted to carry five cartridges, I may use one single catch like 27^e and one double catch like 27^c, the single catch 27^e having at its free end a stop projection of a size to project into the adjoining recesses of the first and second cartridges and hold them therein, and a double catch like 27^c with a stop projection at its right hand free end to project into the right hand side of the recess of the third or middle cartridge and a stop projection on its left hand free end to project into adjoining sides of the recesses of the fourth and fifth cartridges and hold them in place.

In order to readily withdraw said stop projections from the recesses to permit the insertion of cartridges therein and their successive withdrawal as the plate is fed through the gun as hereinafter described, the catches are provided near their free ends with rearwardly curving projections 27^f, having their side edges bent outwardly and rearwardly so that by inserting a tool having an inclined cam surface so as to bring said cam surface under one of the outwardly bent sides of a projection, the catch will be pressed or cammed rearwardly and the stop projection withdrawn from the recess and into inoperative position. This leaves the recess free and clear for the insertion or withdrawal of a cartridge. In some cases, as when loading the plate, it may be desirable to move all the stop projections to their inoperative positions simultaneously and for this purpose a tool may be constructed of such length and provided with a sufficient number of properly positioned cam surfaces, whereby the movement of the tool endwise will cause the cam surfaces to engage and lift all the latches simultaneously. 28 (Fig. 27) is a convenient form of such a tool, having three camming surfaces 28^a, arranged so that they will simultaneously engage and cam rearwardly the three projections 27^f shown in Figs. 19 and 20 and having an upstanding end 28^b which offers a convenient shoulder for exerting pressure on the tool to push it into place, camming rearwardly the spring catches. After the recesses have been filled, the tool

will be withdrawn and the latches will spring into operative position to retain the cartridges in place in the feed plate.

For the automatic feeding of the feed plate transversely of the gun, there are provided on the rear face of the upper flange 27^a of the feed plate a plurality of equally spaced notches 29, (Fig. 18) forming shoulders at their right hand ends, said shoulders being adapted to be engaged by the feed pawl 30 (Fig. 23) operated by each reciprocation of a longitudinally movable element such as the barrel and barrel extension.

A convenient means for effecting the operation of said feed pawl may comprise a horizontally disposed feed pawl lever 31 (Figs. 14, 15, 23 and 24) of substantially bell crank shape, pivoted on a vertical pin 31^a on brackets 31^b arranged on the right hand side of the feed box (Figs. 14 and 16). The top of pin 31^a is engaged by the cover of the feed box and thereby held down in its seat (see Fig. 12). The front arm of the said feed pawl lever extends forwardly to a point adjacent the top of the transverse feed channel 32 (Fig. 12), and carries, on a vertical pivot at its forward end, the feed pawl 30, the free hooked end of which is actuated toward the feed channel and into engagement with the upper flange of the feed plate, when the same is in position in the gun, by the tension of the pawl spring 30^a (Fig. 23) housed in a seat therefor in the front arm of said feed pawl lever and acting through a plunger against the rear face of the pawl. The rear arm of said feed pawl lever 31 extends laterally toward the left hand side of the feed box and is formed at its end, which is thickened vertically by a downward extension 31^c (Fig. 24), with a vertically extending groove 31^d of substantial width and depth.

This groove 31^d is adapted to co-operate with an elongated stud 33^a (Fig. 25) which rocks with the swivel stud 33^b integral therewith and seated in a pivot hole formed some distance below the upper end of a vertical feed lever 33 (Figs. 6, 7 and 25). This feed lever 33 is pivoted on a transverse pivot pin 33^a (Figs. 6 and 16) in a bracket 33^c (Figs. 14 and 15) secured inside the left hand side wall of the feed box. Below said stud 33^a the feed lever extends downward through a longitudinal slot 33^e (Fig. 16) formed in the upper inwardly projecting flange of the left hand side plate of the breech casing and close to the inner surface of said side plate.

Means are provided for yieldingly holding said lever between certain limits of movement and this means may comprise a spring wire 34 (Fig. 26) having its central portion coiled about a groove formed

on the inner end of the feed lever pivot pin 33^a (see Figs. 14 and 15) which is headed on its outer end. The spring extends from its seat on said pivot pin both forwardly and rearwardly along the outside of the bracket 33^c, in which said feed lever is pivoted. At the ends of said bracket, each branch of the spring is placed under some tension to hold the spring and the pivot pin 33^a in assembled relation, by passing each end of the spring under an inwardly projecting stud 34^a (Figs. 6 and 15) provided at each end of the bracket. Each branch of the spring is then bent at right angles to bring it into the path of the feed lever 33, when it is bent downwardly, as at 34^b (Fig. 26) and then inwardly, so that the opposite ends of the spring will be located in the path of the feed lever on opposite sides of the lever bracket, to yieldingly limit the movement of said lever in each direction. The lower end of the feed lever extends downwardly for some distance into the breech casing (Figs. 16 and 17) and lies in the path of a lateral outwardly projecting stud 34^c on the left hand arm 8^a of the barrel extension (Figs. 16, 17 and 28) the rear portion of which, as hereinbefore described, is spaced some distance from the adjacent side wall of the breech casing.

The stud 34^c and the end of the feed lever are so positioned that during the last portion of the recoil of the barrel and barrel extension, after a shot is fired, the stud 34^c will engage the lower end of the feed lever 33 to swing it rearwardly, this in turn through the stud 33^a (as the same is located below the pivot point of the feed lever) swinging the feed pawl lever 31 to actuate the feed pawl 30 to the left, from the position shown in Fig. 15 to that shown in Fig. 14, so as to cause the hooked end of the feed pawl to ride idly toward the left along the rear face of the top flange of the feed plate, to a point to the left of the next succeeding notch 29 where it slips into position to engage the shoulder of said notch on the counter recoil of the barrel and barrel extension. During the last part of the rearward movement of the feed lever, it engages the inwardly projecting end of the rear arm of feed lever spring 34, and by its further rearward movement places said spring under tension. When the barrel extension is almost at the limit of its recoil, the lower end of the feed lever snaps past its engaging stud 34^c and the spring 34, being under tension, returns it forward some distance, to insure that on the counter recoil of the barrel and barrel extension the stud 34^c will engage the lever on its rear face and swing it forwardly, thus swinging the horizontal feed pawl lever 31 to

actuate the feed pawl 30 to the right, from the position shown in Fig. 14 to that shown in Fig. 15, the hooked end of the feed pawl catching on the shoulder of the adjacent notch 29 and feeding the feed plate a proper distance from left to right in the transverse feed channel 32, to position the next cartridge to be projected into the barrel chamber. During the last of the forward movement of the vertical feed lever, the inwardly projecting end of the front arm of the spring 34 engages the end of said feed lever, is placed under tension, and when the end of said lever is released by the stud 34^c during the final forward movement of the barrel extension, swings said lever back a short distance, thereby bringing it into position to be again engaged on its front face by said stud on the next recoil of the barrel extension. At the time the lever 33 engages the front arm of spring 34 and places it under tension, the pawl spring 30^a is also placed under tension (see Fig. 15) so that when the stud 34^c finally passes beyond the lever 33, spring 34 and spring 30^a both act to swing the lever 33 rearwardly to substantially the position shown in Fig. 6 and act to swing lever 31 from the position of Fig. 15 toward the position of Fig. 14.

To prevent any movement of the feed plate toward the left, a stop pawl 35 (Figs. 6, 7 and 17) is provided. This pawl may be conveniently mounted to move in a vertical plane about a pivot pin supported under the top cover of the feed box 4, and being actuated to its normal position by a spring. The pawl co-operates with a series of equally spaced notches 35^a (Fig. 18) formed in the top of the feed plate. By lifting the cover of the feed box the stop pawl will be disengaged from the feed plate and the same can be withdrawn to the left if the hooked end of the feed pawl 30 is swung back.

It will be noted, by reference to Fig. 18, that in addition to the recesses 29 which form the shoulders for engagement by the feed pawl, there are additional recesses 36 at the right and adjacent each shoulder. These are for the purpose of weakening these shoulders so that in case anything jams in the feed channel during the forward movement of the barrel, the shoulder on the feed plate would give way and prevent further destruction. The damaged feed plate can be discarded and replaced with a fresh one.

The means for automatically feeding the cartridges into the barrel chamber and the manner in which said means operate will now be described.

A cartridge carrier 37 (Figs. 6, 7, 12 and 13) is pivoted in the rear of the transverse channel 32 in the feed box 4 on a transverse

pivot pin 37^a (Figs. 2, 5, 12, 13, 14 and 15) passing through said carrier and the sides of the feed box. The carrier is held centrally of the gun by having spaced forward projections 37^b (Figs. 6, 12 and 13) on its hub straddle a rearward projection 38 (Figs. 12, 13 and 16) at the bottom of the transverse wall forming the rear wall of the transverse feed channel 32 and also by having its long forwardly projecting arm, which is shaped so as to pass over the feed channel and is inclined downwardly and forwardly, pass through a space formed between the inner ends of forward guide members 38^a and 38^b (Figs. 14, 15 and 17) for the feed plate, one projecting inwardly from the right hand side of the feed box, and the other from the left hand side. Member 38^a which projects inwardly from the right hand side of the feed box has a cam surface on its inner edge, shown in Fig. 17, for camming down the cartridges out of the feed plate, as hereinafter described. The projections 37^b have additional functions hereinafter set forth.

When the parts are in the position shown in Figs. 12, i. e., with the barrel and barrel extension in forward position and the lock frame in its rearward position ready for the injection of a new cartridge, a notch 37^c (Figs. 6 and 15) having a rearwardly and downwardly inclined shoulder formed in the forwardly and downwardly extending forward arm of the carrier and on the right hand side thereof, is engaged by the nose of a carrier latch 39 (Figs. 14 and 15) pivotally mounted on a vertical pivot pin 39^a in a bracket on the right hand side of the feed box. The top of this pivot pin engages the feed box cover or a stud projecting downwardly therefrom and is thereby held in its seat (Fig. 12). This latch is actuated inwardly to bring its nose into engagement with said notch on the carrier by a spring 39^b (Fig. 14) seated in a recess in the latch and bearing at its outer end against the side of the feed box. The swing of the latch 39 under the influence of its spring is limited by the engagement of the shoulder 39^c (Fig. 14) with an abutment on the side of the feed box. Pivotaly mounted by means of a transverse pin 40^a, on a short rearwardly projecting arm of said carrier is a dog 40 (Figs. 6, 7, 12 and 13) adapted, when the carrier is in its normal position and the lock frame is in forward position (Fig. 6) to project rearwardly and downwardly into the path of the lock frame. A strong helical spring 40^b (Figs. 6 and 13), seated in a recess in said carrier, acts to depress the dog by acting through a plunger against an upward projection on said dog.

When the parts are in firing position, shown in Fig. 6, and the lock frame is either

manually or automatically retracted, during such rearward movement the upwardly projecting central portion of the lock frame, which is rounded at its upper rear portion as shown (Figs. 6 and 7) engages the under surface of said dog and raises it against the tension of its spring until, in the further rearward movement of said frame, the rear lower edge of the dog slides on the flat horizontal top surface of said frame. The rounded upper rear portion of the lock frame acts as a cam to raise the dog and compress the spring gently, avoiding severe strain on these parts. Also the raising of the dog and compressing of its spring helps to absorb the recoil and slow up the rearward movement of the parts. A notch 40° (Figs. 6 and 13) is formed in the top surface of the lock frame, against the rear vertical shoulder of which said lower edge of the dog engages to arrest the forward movement of the frame following recoil and hold said frame in a rearward position as shown in Figs. 7 and 12.

When the dog 40 engages in the notch 40° to arrest the forward movement of the lock frame following recoil, there is a substantial impact and to assist in buffering the shock thereof the pivot pin 37^a should preferably be spring tempered. This pivot pin takes its bearings at its ends in the sides of the feed box, and I counterbore at each end the hole in the carrier 37, where the carrier is pivoted on the pin, whereby the carrier takes its bearing on the center of the pin which being spring tempered acts as a spring to take up the shock of impact between the dog and the lock frame. Also, as appears in Fig. 5, one end of said pin has a stud which is positioned in a corresponding recess in the side of the feed box whereby the pin cannot turn in its bearings, so that the lock frame will always be stopped at the same point even though a pin which is somewhat bent should be used for this pivot pin.

Assume now that the lock frame has been manually drawn rearwardly against the tension of the reaction spring until the dog engages in the notch 40° and is held in its rearward position by the dog pivoted to the carrier in the manner above described (see Fig. 12), and that a feed plate, carrying cartridges, is inserted into the feed channel from the left hand side. After the plate has been inserted a distance sufficient to bring the second cartridge therein over a laterally projecting ledge 41 (Figs. 14, 15 and 17) secured to the left hand side of the breech casing, the spring catch 27° (Fig. 19) holding the first two cartridges in their recesses is cammed back by a cam plate 42 (Figs. 6, 7 and 12) fixed in the feed channel, thus releasing said cartridges. With the further inward movement of the plate, the first cartridge comes into engagement at its right

hand side and near its rear end with the downwardly inclined inner cam surface of the plate 38^a (Figs. 12, 13 and 17) secured to right hand side wall of the feed box, and is thus positively cammed downward out of the feed plate into the space between the side arms of the barrel extension (see Fig. 17).

As the cartridge commences its downward movement under the influence of the cam face of the plate 38^a it engages a downwardly projecting stud 39^a (Figs. 12, 13 and 14) at the end of the carrier latch 39 and swings the latch outwardly against the tension of its spring so that it passes out of engagement in the notch 37° in the forwardly extending arm of the carrier 37, from position shown in Fig. 14 to that shown in Fig. 15. Thereby the forward end of the carrier will be moved downwardly by the expansion of the strong helical spring 40^b (Fig. 13) arranged between said carrier and the dog 40, and, by its engagement with the cartridge (Fig. 13), force the same downwardly until it rests on the cartridge guide lever 43 (Figs. 12, 13 and 41) which co-operates with said forward end of the carrier and with the ejector hereinafter described to hold said cartridge against any but endwise movement with its nose in position to enter the barrel chamber upon forward movement of said cartridge.

The cartridge guide lever 43 is loosely pivoted at its rear end on a fixed stud 43^a (Fig. 28) projecting inwardly from the rear end of the right hand arm 8^b of the barrel extension. At the rear end of the said lever is a lateral extension 43^f (Fig. 41) which fits into a recess 43^e (Fig. 36) in the side of said arm 8^b, the forward end of said extension engaging in a curved groove at the front end of said recess. In assembling, the lever is placed on its pivot stud with its free end pointing downwardly and is then swung upwardly into place, the lateral extension 43^f engaging in the recess 43^e and its forwardly projecting end registering in the groove in said recess, which limits the upward swing of said lever and prevents lateral displacement thereof. The downward swing of the lever is limited by the stop lever 44 (Fig. 34) when the same is in assembled position as hereinafter described. The cartridge guide lever is normally held yieldingly in a raised position (Figs. 12 and 29) by a spring pressed ball 43^b (Fig. 32) located in a recess in the arm 8^b of the barrel extension and adapted to engage in a rounded depression in the adjacent side of said lever. When the carrier 37 is depressed as above explained, and the cartridge strikes the cartridge guide lever 43, the lever is moved from its raised position to an inclined position (Figs. 13 and 36) with the right hand side of the cartridge resting on the ledge 43^c (Figs. 32

and 41) of said guide lever and in position to be inserted in the barrel chamber, as shown in Fig. 13.

The cartridge guide lever 43 is held in this forwardly and downwardly inclined intermediate position as shown in Fig. 13 by the stop lever 44 (Fig. 13), which is pivoted under the bottom face of the right hand arm 8^b of the barrel extension on a vertical stud 44^a (Figs. 28 and 29) projecting downward from said bottom face of said arm 8^b. The head of the stud is substantially rectangular and is fixed at an angle to the plane of the arm 8^b. By passing this rectangular head through the corresponding opening 44^b (Fig. 34) in the stop lever, the lever can be swung into position under the arm 8^b.

This stop lever 44 is formed at its forward end with an inward projection 44^c (Fig. 34) adapted to project inwardly beyond the inside face of the arm 8^b of the barrel extension and into the path of the cartridge guide lever 43 to hold it in its intermediate inclined position, as shown in Fig. 13. The stop lever 44 is normally held in its operative position, with its projection 44^c in the path of the cartridge guide lever, by the flat spring 45 (Figs. 28 and 29) secured by a common form of bayonet lock to the outside face of the arm 8^b of the barrel extension as at 45^a (Fig. 36). At its forward end said spring has a downwardly projecting lip 45^b (Figs. 36 and 38) which engages the right hand side of the forward arm of the stop lever 44, holding it in its operative position, with its projection 44^c in the path of the cartridge guide lever 43. The inward movement of the front arm of the stop lever 44 under the influence of spring 45 is limited by a pin 44^a (Figs. 28, 29 and 34) which projects upwardly from the top face of the stop lever 44 and into a shallow recess in the bottom face of the arm 8^b of the barrel extension. By engaging the inner end of this recess the pin limits the movement of the stop lever under the influence of the spring 45. At its rear end the stop lever 44 has a downward projection 44^e (Fig. 34) formed with an inclined surface on its rear outer edge, for a purpose hereinafter described.

When the forward arm of the carrier 37 is released by the catch 39 and forced downward under the influence of spring 40^b as hereinbefore described, the angular relation between the carrier and its dog 40 is necessarily changed (Fig. 13) and this change in the relation of these parts is conveniently made use of to automatically release said dog from the notch in the lock frame, permitting the lock frame to move forwardly under the influence of the reaction spring. For this purpose said dog is provided with a rearward extension or tail 40^a, projecting from the rear face of the dog. Simultaneously with the downward swinging of the

forward arm of the carrier, the end of this tail is pressed downwardly against the top face of the lock frame, lifting the dog out of the notch 40^c and thereby releasing the lock frame to move forward under the tension of the reaction spring 17. The tail is preferably longitudinally adjustable, as by a screw-threaded connection, making it possible to vary the time elapsing between the release of the carrier by its latch 39 and the release of the lock frame and thereby insure that the lock frame is not released until the cartridge is in position to be fed into the chamber of the barrel. The right hand projection 37^b (Fig. 6) on the hub of the carrier engages the top of the right hand arm 8^b of the barrel extension and serves to hold the carrier from downward movement, unless the barrel and barrel extension are in their forward firing position. At the rear end of the arm 8^b of the barrel extension is a cut-away portion 46 (Figs. 12 and 36) which underlies said right hand projection 37^b when the barrel has moved to its forward position, permitting the downward rotation of the carrier and the release of the lock frame. Therefore the carrier cannot be lowered to unlock the lock frame and position a shell for injection into the chamber until the barrel is in battery. This is a safety device.

During the forward movement of the lock frame a forward extension or charger 47 (Figs. 44 and 13) at the top of said frame engages, through a downward projection 47^a formed at its forward end, the base of the cartridge and pushes it into the barrel chamber (Figs. 6 and 13). For this purpose the cartridge guide lever 43 is formed with a suitably shaped longitudinal seat 43^c (Figs. 12 and 32) on which the right side of the cartridge will rest and be guided in its forward movement. After the forward portion of the cartridge has been inserted some distance into the barrel chamber, the rear end of the cartridge is permitted to drop to bring its axis into substantial alignment with the barrel axis. In order to drop the rear end of the cartridge it is necessary to further lower the cartridge guide lever 43, which is held in its forwardly and downwardly inclined intermediate position above described by the projection 44^c of the stop lever 44. To further lower said guide lever, there is mounted on the front right hand end of the lower widened horizontal portion 12^c of the lock frame an upwardly projecting plate 48 (Figs. 6, 42 and 43) its inner face forming a cam surface as shown in Fig. 42. When the lock frame reaches the position in its forward motion where it is desirable to have the rear end of the cartridge lowered to substantial alignment with the axis of the barrel, the cam surface of plate 48 engages the outer face of the down-

wardly projecting rear end 44° of the stop lever 44 and, as the lock frame moves forwardly (see Figs. 16 and 17) the rear arm of the stop lever is cammed inwardly, there-
 5 by swinging outwardly the front arm and withdrawing the projection 44° from under the cartridge guide lever and permitting the latter to drop until it is arrested by a pin
 10 49 (Figs. 30, 34 and 38), which projects inwardly and upwardly from the rear arm of said stop lever into the path of the guide
 15 lever 43 and which limits its downward movement as shown in Fig. 38. The dropping of the guide lever to its lowest position (Fig. 38) lowers the rear end of the cartridge which is now part way in the chamber so that the axis of the cartridge is in substantial alignment with the barrel axis.

The cartridge guide stop lever 44 being of substantial length and being pivoted near its center, has considerable spring at both ends and when the cartridge guide lever 43 bearing a cartridge engages said stop lever on its downward movements to both its intermediate and lowest positions, the engagement is a yielding one, preventing any sudden jar on the cartridge which might cause a premature explosion of cartridges of a sensitive character.

It will be noted that the cartridge forcing means, i. e., the lock frame, also actuates the stop lever to permit the cartridge guide lever to drop into its lowest position for positioning the cartridge for complete injection into the barrel chamber, whereby the moment for dropping down the cartridge head during the forward movement of the lock frame can be accurately timed by the action of the cartridge forcing means itself.

The lock frame meanwhile continues its forward movement, inserting the cartridge fully into the chamber, and raising the breech block as hereinbefore described. By reference to Fig. 6 it will be noted that when the lock frame is in its forward position the charger and the extractor (hereinafter described) project forwardly of the breech block and beyond the rear face of the barrel into a recess 7^a cut into the rear face of the barrel and barrel extension, just above the chamber (see Figs. 6, 7, 12, 13, 29 and 30). In rising, the breech block will return the cartridge guide lever to its highest position by the engagement of a rearwardly projecting stud 50 (Figs. 28 and 30) on said breech block with the under side of the forward end of said lever as shown in Fig. 28.

The breech block is formed at the top with a forwardly and downwardly sloping top surface, which engages the face of the cartridge and seats it firmly in the chamber.

For the extraction of the empty shells, the said forward extension or charger 47 on the lock frame is provided with an extractor 51 (Figs. 44, 48 and 49) slidably

mounted in a forwardly and downwardly inclined seat therefor in the front face of the charger, and guided for up and down movement therein by lateral ribs 51^a (Fig. 50) thereon engaging in corresponding
 70 grooves in the front face of said charger. The extractor is normally pressed downwardly to its operative position by a flat spring 51^b (Figs. 48, 49), one end of which
 75 bears upon the upper end of the extractor at 51^c (Figs. 48 and 49) while its other end is rigidly secured in a T-slot 47^b (Fig. 48) formed in the top surface of the lock frame. The lower projecting end of the extractor 51 which is
 80 adapted to engage in front of the projecting rim of the cartridge head, is bevelled on its forward face as shown in Fig. 49 whereby, in the forward movement of the lock frame to push the cartridges into the barrel the
 85 engagement of said bevelled surface with the cartridge rim cams the extractor upwardly to permit it to pass over said rim and snap down in front of the same into the position shown in Fig. 6. The rim of the cartridge
 90 is now held between the head of the charger and the point of the extractor, which, on the forward movement of the lock frame to insert the cartridge in the chamber, prevents the cartridge from getting ahead of the
 95 charger. The forward movement of the lock frame is slowed down and buffered by the action of the breech block actuating lever and breech block as above explained, thereby slowing down the forward move-
 100 ment of the cartridge into the chamber. The cartridge stops when the lock frame stops and the final forward movement of the cartridge is effected by the front face of the breech block wedging along the rear
 105 face of the cartridge. If the rim of the cartridge were not held by the extractor from moving in advance of the lock frame it might be thrown ahead of the lock frame and into the chamber with great force which
 110 might start the projectile from its case, decreasing the efficiency of the cartridge when fired. Also if the lock frame were stopped too suddenly and with too violent an impact, the projectile might be started
 115 from its case. Now, after the recoil of the barrel and lock frame on the firing of a cartridge, when the barrel moves forward, the lock frame remaining in its rearward position locked against forward movement
 120 by the engagement of dog 40 with the lock frame, as hereinbefore described, said extractor, being in the position as shown in Fig. 7, holds the shell against forward movement and the shell is thereby with-
 125 drawn from the forwardly moving barrel. During such withdrawal the rim of the shell is guided horizontally and until completely withdrawn from the barrel, by the inwardly projecting ledges 52 (Figs. 16
 130

and 17) on the inside bottom portion of the barrel extension arms and by the under side 43^a (Fig. 12) of the cartridge guide lever 43, which is now in its uppermost position, having been raised by the breech block, as hereinbefore described. As the barrel and barrel extension approach their forward position, the rear ends of the aforesaid ledges 52 supporting the cartridge shell head at the bottom pass forwardly beyond said head, and since the shell is entirely withdrawn from the chamber, it is free to fall downwardly through the open bottom of the breech casing.

To positively eject the shell, there is provided a shell ejector 53 (Fig. 33) comprising a two-armed lever pivoted at 53^a (Fig. 28) to the left hand arm 8^a of the barrel extension near the rear end thereof. Said shell ejector has a long forward arm and a short rearward arm, and is provided on opposite sides of its pivot with downward projections 53^b and 53^c (Fig. 33) which are formed with inclined cam surfaces and are adapted to co-operate, in effecting the movements of the ejector, with a lateral ejector stud 54 (Figs. 12, 13 and 47) on the left hand forward side of the upwardly projecting portion of the lock frame. The ejector is frictionally held in all positions thereof by means of a frictional spring 53^d (Fig. 28) housed in a recess in the ejector and bearing at one end against the adjacent side of the barrel extension. When the barrel on its counter recoil has reached the position where the rear ends of the supporting ledges 52 on the barrel extension arms have passed beyond the shell, the ejector is in the position shown in Fig. 29 with its forward end projecting over the rear end of the shell, and in the further forward movement of the barrel (the lock frame being held in a rearward position by the dog 40), the ejector stud 54 on the lock frame engages the rear downward projection 53^b on said ejector, which is moving rapidly forward with the barrel and barrel extension, and cams it up, thus rapidly moving the forward arm of the ejector down to strike the top of the shell and forcibly eject it down and out through the open bottom in the breech casing. While in this lower position, where it remains under the influence of the spring 53^d until again engaged by the ejector stud, the forward arm of the ejector assists in guiding the succeeding cartridge head during the first part of its movement from the feed plate, preparatory to being inserted in the barrel chamber by the lock frame. By mounting the ejector on the barrel extension and actuating it by a fixed stud on the lock frame the moment of actuation of the ejector can be properly timed so that it will operate at the proper moment to strike and positively eject the shell. When the rear

projection 53^b of said ejector is engaged by ejector stud 54, it is moving forwardly at high speed, and is therefore rotated to strike the shell with great force, thereby positively throwing said shell clear of the gun even should the gun be fired upside down. During the subsequent forward movement of the lock frame, when the same has been released, the ejector stud 54 thereon engages the forward downward projection 53^c of said ejector and cams the forward arm of the same into its upper position, where it is held in position by the spring 53^d, to engage over the rear end of the next shell to be ejected.

During the last portion of the forward movement of the lock frame the forward arm of the carrier 37 is raised and held in such raised position while the lock frame is forward by the longitudinal top surface of the carrier cam 55 (Figs. 6, 7, 12, 13, 43 and 44) projecting rearwardly of said frame and slightly to the left of the central plane of the gun, said cam surface co-operating for this purpose with the left hand one of the spaced projections 37^b on the hub of the carrier. Fig. 13 shows the projection 37^b in position to be thus engaged by the carrier cam 55 on the forward movement of the lock frame, and Fig. 6 shows them in engagement with the forward arm of the carrier 37 raised thereby. When the carrier arm is brought to its upper position the carrier latch 39, under the action of its spring engages in the notch 37^c provided for the same to hold said carrier in this position.

During the forward movement of the barrel and barrel extension after their recoil, the feed plate is fed transversely as hereinbefore described and the next cartridge therein is brought against the downwardly projecting stud 39^a on the carrier latch 39 to automatically trip the same and permit the carrier 37 to rotate, and this cartridge will then be fed into the chamber of the barrel in the manner hereinbefore described.

From the foregoing description it will be seen that the firing will continue automatically as long as there are cartridges in the feed plate, if the trigger is held back, and that any number of cartridges can be fired continuously by holding back the trigger and supplying a new feed plate loaded with cartridges as soon as the cartridges in one plate are exhausted.

Also when the last cartridge has been fired the breech will remain open since the carrier latch will not be disengaged from the carrier to permit the carrier to rotate and unlock the lock frame from engagement with the dog 40, thereby avoiding the necessity of manually retracting the breech mechanism, if it is desired to recommence firing. A new feed plate loaded with car-

tridges may be inserted into the feed channel to automatically actuate the mechanism as above described.

It will be noted that the gun will operate without the carrier latch 39 except that the lock frame will not remain locked in its rearward position after the firing of the last cartridge and it would be necessary to manually pull back the lock frame and hold it in rearward position while a new feed plate is being inserted and the first cartridge fed into position for insertion into the barrel chamber. If the carrier latch were omitted, on each recoil of the parts after firing the carrier would remain in its upper position locking the lock frame during the forward movement of the barrel, by the engagement of the right hand projection 37^b on the hub of the carrier with the top face of the right hand barrel extension arm. This projection 37^b engages this arm, holding the carrier raised until near the end of the forward movement of the barrel when the cut away portion 46 of the barrel extension arm permits the carrier to rotate, pressing the cartridge down into inclined position and releasing the lock frame for forward movement.

The shoulder 7^b projecting forwardly of the top of the barrel extension and projecting over the top of the barrel (Figs. 6, 12, 28, 29 and 31) is a safety device. In case the next cartridge to be fed into the barrel drops prematurely from the feed plate while the barrel is in its rearward position with its rear end under the feed box as shown in Fig. 7, the cartridge will engage the shoulder 7^b instead of the barrel and any jamming of the cartridge on the forward movement of the barrel and barrel extension will be avoided.

The buffer may comprise a plunger 56 (Fig. 7) mounted for longitudinal movement in the bottom of the buffer housing 56^a. The buffer housing is integral at its rear with the front face of the back plate, to the right of the guide plate 17^t (see Fig. 59). The housing is rectangular with two side plates with grooves at front and top in which the front plate 56^b and top plate or cover 56^c can slide into position. A stud (not shown) projects into one side groove to limit the downward movement of the front plate when slid into position so that the bottom of the plate will just touch the top of the rear raised portion of the plunger. The ledge projecting forwardly from the front plate at the bottom prevents dirt or foreign matter from getting into the buffer housing when the plunger is in its forward position. The forward movement of the plunger is limited by a fixed stud 56^d projecting upwardly from the bottom of said housing into a longitudinal groove in the bottom face of said plunger. Said

plunger projecting forwardly from the lower portion of the buffer housing is in position to be struck by the rear end of the lock frame, as said lock frame recoils. At its rear end said plunger is formed with a downwardly and rearwardly inclined surface arranged to contact with a similar surface on the lower front end of a vertically slidable brake block 56^e, which is formed at its upper end with a forwardly and downwardly inclined surface adapted to contact with a similar surface on a second brake block 56^f. Between the upper surface of the second brake block and the top closure 56^e of the buffer housing is provided a powerful coiled spring 57. It will be seen that any rearward movement of the plunger 56 will act to compress the coiled spring and the brake blocks will press against the back and front sides of the buffer housing to powerfully brake such rearward movement and bring the lock frame to rest gradually and without violent shock and start the same on its return movement in co-operation with the reaction spring. The top 56^e of the housing slides rearwardly in grooves at the top of the housing side plates and may be slid forwardly to disassemble and remove the spring and brake blocks. The pressure of the spring keeps it normally in place. Preferably I make the plunger of steel, brake block 56^e of brass and block 56^f of fiber. If these were all of steel they might stick and wear even though well oiled, but the brass and steel, and the brass and fibre contacts form easy sliding surfaces. Also the use of fibre decreases the weight. I also preferably make the bottom plate of the housing of bronze so that there will be an easy slide between it and the plunger.

By the buffer action just described, in which the action of the spring is supplemented by the braking action resulting from the frictional engagement of the buffer blocks with each other and with the bottom and rear walls of the buffer housing, the buffer is rendered comparatively "dead," that is, it prevents a too rapid expansion of the spring in returning the blocks to their normal position, thereby avoiding the strain and breakage which might result from a too violent forward return of the lock frame against the dog.

If the lock frame is locked in its rearward position, as it will be after the ejection of the last cartridge, to disassemble the gun the top of the feed box 4 should be raised and the carrier catch 39 snapped back manually out of engagement with the cartridge carrier 37. The action of the spring 40^b and the tail 40^a, as hereinbefore described, will lift the dog 40 from locking engagement with the lock frame which will be returned to its forward position under the influence of the reaction spring. The

tension of the reaction spring is now at its minimum and the end of its guide rod can be readily pushed in by applying the point of a cartridge to the end of the head 17^e, until it passes from its seat in the hole in the rear plate 5 and the rear plate slid downwardly and withdrawn from the casing. The spring and guide rod and guide plate can now be withdrawn as a unit. Also by pulling back on the finger piece of the actuator lever 11 the lock frame and the parts mounted thereon can be withdrawn rearwardly from the casing. I have described above the disassembly of the parts mounted on the lock frame. The pin 33^d on which the feed lever 33 is mounted can be readily withdrawn against the tension of the spring 34 and the spring and feed lever withdrawn upwardly through the top of the feed box. The pin 31^a on which the feed pawl lever is mounted can be withdrawn vertically from its seat and the feed pawl lever withdrawn. The carrier catch and its pivot pin can be withdrawn vertically from the bracket in which said pin is seated. The pin 15^e can now be knocked out, the breech block manually raised and the breech block stop removed rearwardly from the barrel extension. The breech block will now slide down and out of engagement with the barrel extension. The rear lock nut 9^d of the barrel extension lug can now be taken off and the barrel and barrel extension slid rearwardly through the casing. The parts carried by the barrel extension can easily be disassembled therefrom.

What I claim and desire to secure by Letters Patent is:—

1. In an automatic firearm, the combination of a breech casing, a barrel supported therein, a reciprocating member mounted at the rear of said barrel, a breech block movable transversely of the axis of the barrel to open and close the breech of the barrel, and means actuated by the movements of said reciprocating member to move the breech block into and out of breech closing position.

2. In an automatic firearm, the combination of a breech casing, a barrel supported therein, a reciprocating member mounted at the rear of said barrel, a breech block movable transversely of the axis of the barrel to open and close the breech of the same, and means carried by said reciprocating member to move said breech block to open and close said breech.

3. In an automatic firearm, the combination of a breech casing, a barrel supported therein, a reciprocating member mounted at the rear of said barrel, a breech block movable transversely of the axis of the barrel to open and close the breech of the same, means carried by said reciprocating mem-

ber to move said breech block to open and close said breech and means to interlock said barrel, block and reciprocating member when said block is in breech closing position.

4. In an automatic firearm, the combination of a breech casing, a barrel supported therein, a reciprocating member mounted to the rear of said barrel, a breech block movable transversely of the axis of the barrel to open and close the breech of the same, means actuated by the rearward movement of said member to move said breech block from breech closing to breech opening position and actuated by the forward movement of said member to return the breech block to breech closing position, and means to interlock said barrel, breech block and member when the breech block is in breech closing position.

5. In an automatic gun, the combination of a breech casing, a barrel supported therein, a member mounted for longitudinal movement at the rear of said barrel, a breech block mounted for sliding movement in a plane transverse to the axis of the barrel, means for feeding a cartridge between the rear end of the barrel and said member when said member is in its rearward position whereby said cartridge will be engaged by and inserted into said barrel on the forward movement of said member, and breech block actuating means rendered operative on the rearward movement of said member to slide the breech block from breech closing position and out of the path of movement of said cartridge and on the forward movement of said member to slide said breech block into breech closing position after said cartridge has been inserted into the barrel chamber.

6. In an automatic gun, the combination of a breech casing, a barrel mounted for longitudinal movement therein, a member mounted for longitudinal movement at the rear of the barrel, a breech block mounted for sliding movement in a plane transverse to the axis of the barrel, means actuated by the rearward movement of said member to slide said breech block from breech closing position to a position outside said casing and actuated by the forward movement of said member to slide the breech block to breech closing position, and means to interlock said barrel, breech block and member when the breech block is in breech closing position.

7. In an automatic firearm, the combination of a breech casing, a barrel and barrel extension mounted for longitudinal movement therein, a reciprocating member mounted in the rear of said barrel, a breech block mounted on the barrel extension and movable transversely to the axis of the barrel, means actuated by the movement of said

reciprocating member to move the breech block into and out of breech closing position, and means to interlock said breech block and said reciprocating member when said block is in breech closing position.

8. In an automatic firearm, the combination of a breech casing, a barrel mounted therein, a reciprocating member mounted at the rear of said barrel, a breech block movable transversely of the axis of the barrel to open and close the breech of the same, and means to impart said movement to said breech block comprising an actuating lever mounted on said reciprocating member and adapted to engage said breech block and move it into breech closing and breech opening position during the forward and rearward movements of said member.

9. In an automatic firearm, the combination of a breech casing, a barrel mounted therein, a reciprocating member mounted at the rear of said barrel, a breech block movable transversely of the axis of the barrel to open and close the breech of the same, and an actuating lever adapted to operatively connect said reciprocating member and said breech block, and means to actuate said lever on the forward and rearward movements of said member whereby the breech block is moved into breech closing and breech opening position on the reciprocation of said member.

10. In an automatic firearm, the combination of a breech casing, a barrel and barrel extension mounted for longitudinal movement therein, a lock frame also mounted for longitudinal movement in said casing, a breech block movable transversely of the axis of said barrel to open and close the breech of the same, and means for moving said breech block during the movements of said lock frame comprising a lever and cam means for operating said lever.

11. In an automatic firearm, the combination of a breech casing, a barrel mounted therein, a reciprocating member mounted at the rear of said barrel, a breech block mounted for movement transversely to the axis of the barrel to open and close the breech of said barrel, means for automatically imparting said movement to said breech block comprising an actuating lever mounted on said member and adapted to engage said breech block, and cams secured to said casing adapted to co-operate with said lever.

12. In an automatic firearm, the combination of a breech casing, a barrel and barrel extension mounted for longitudinal movement therein, a reciprocating member mounted at the rear of said barrel, a breech block mounted on said barrel extension for movement transverse to the axis of the barrel to open and close the breech of said

barrel, and means actuated by the movement of said reciprocating member to impart said opening and closing movements to said breech block.

13. In an automatic firearm, the combination of a breech casing, a barrel and barrel extension mounted therein, a reciprocating member mounted at the rear of said barrel, a breech block mounted on said barrel extension and having vertical reciprocatory movement thereon to open and close the breech of said barrel, and means to impart said movement to said breech block comprising an actuating lever mounted on said reciprocating member and adapted to engage and move said breech block into and out of breech closing position during the reciprocation of said member.

14. In an automatic firearm, the combination of a breech casing, a barrel and barrel extension mounted for longitudinal movement therein, a reciprocating lock frame mounted at the rear of said barrel, a breech block mounted on said barrel extension and having vertical sliding movement thereon to open and close the breech of said barrel, and means for automatically imparting said movement to said breech block comprising an actuating lever mounted on said lock frame and adapted to engage said breech block and cams secured to said casing adapted to co-operate with said lever.

15. In an automatic firearm, the combination of a breech casing, a barrel and barrel extension mounted for longitudinal movement therein, a reciprocating member mounted at the rear of said barrel, a breech block slidably mounted on the barrel extension, an actuating lever pivotally mounted on said reciprocating member and adapted to engage said breech block to move it into and out of breech closing position on the forward and rearward movement, respectively, of said member, cam means on said lever and said casing, respectively, adapted to co-operate to actuate said lever, a lever strut mounted on said lever and a spring on said member engaging said strut, as and for the purpose described.

16. In an automatic firearm, the combination of a breech casing, a recoiling barrel and barrel extension, a breech block slidable transversely of the axis of said barrel to open and close the breech of the same, a longitudinally sliding member at the rear of said barrel, a lever carried by said member for moving said block, and cams secured to said casing and cooperating with said lever to positively actuate it during the reciprocatory movements of said member, and means for yieldingly holding said lever at either limit of its throw.

17. In an automatic firearm, the combination of a breech casing, a barrel and barrel

extension mounted for longitudinal movement therein, a reciprocating member mounted at the rear of said barrel, a breech block mounted for movement transverse to the axis of the barrel, an actuating lever pivotally mounted on said member and adapted to engage said breech block, cam means on said lever and casing, respectively, adapted to cooperate to rock said lever to move the breech block to breech closing and breech opening positions on the forward and rearward movements respectively of said member, a spring mounted on said member and a strut mounted on said lever and engaged by said spring, said strut being adapted to pass dead center position on each rock of said lever to raise and lower the breech block, whereby said lever will be yieldingly held in position at the end of each said rock.

18. In an automatic firearm, the combination of a breech casing, a barrel and barrel extension mounted for longitudinal movement therein, a reciprocating lock frame mounted at the rear of the barrel, a breech block mounted for vertical sliding movement on the barrel extension, means mounted on said lock frame for engaging the breech block on the forward movement of the lock frame and raising said block into breech closing position and for lowering said block on the recoil of said frame, means for yieldingly holding said block actuating means in raised position and in lowered position, and means for interlocking said frame and block when the block is in its raised position and the frame is in its forward position.

19. In an automatic firearm the combination of a breech casing, a barrel mounted therein, a reciprocating member mounted at the rear of said barrel, a breech block mounted for movement transversely of the axis of said barrel to open and close the breech of same, and breech block actuating means for operatively connecting said block and said member, means for rotating said actuating means to move said block to breech closing position on the forward movement of said member, said connection between said actuating means and said block having a lost motion at the limit of the breech closing movement of said block, whereby said actuating means may rebound without moving said block from the limit of its breech closing position.

20. In an automatic firearm, the combination of a breech casing, a barrel mounted therein, a reciprocating member mounted at the rear of said barrel, a breech block mounted for movement transversely of the axis of said barrel to open and close the breech of said barrel, and breech block actuating means engaging said block on the

forward and rearward movements of said member to move said block, said engagement between said actuating means and said block having a lost motion connection at the limit of the breech closing movement thereof whereby said actuating means will not engage and move said block on the initial movement of said frame and actuating means following discharge.

21. In an automatic firearm, a breech casing, a barrel and barrel extension mounted for longitudinal movement therein, a reciprocating lock frame mounted at the rear of said barrel, a breech block mounted for transverse movement on said barrel extension to open and close the breech of said barrel, a breech block actuating lever mounted on said frame and adapted at its forward end to engage said block, and means whereby the forward end of said lever engages said block on the forward movement of said frame, raises said block to breech closing position and holds it in said position until after the initial recoil movement of said frame following discharge.

22. In an automatic firearm, the combination of a breech casing, a barrel supported therein, a breech block movable transversely of said barrel to open and close the breech of the same, a member at the rear of said barrel mounted for longitudinal reciprocatory movement in said casing, a lever carried by said member and adapted to operatively engage said breech block, said engagement having a lost motion connection at the limit of the breech closing movement, whereby said lever moves independently of said breech block during the initial portion of the movement of said lever in the direction for opening the breech and during the final portion of the movement of said lever in the opposite direction, and a locking shoulder on said lever for engagement with said breech block during such independent movement for holding said block in its closed position.

23. In an automatic firearm, the combination of a breech casing, a barrel mounted therein, a reciprocating member mounted at the rear of said barrel, a breech block mounted for movement transversely to the axis of the barrel, and breech block actuating means mounted on said member adapted on the forward movement of said member to engage said block and move it to breech closing position, and on the rearward movement of said member to engage said block, move it from breech closing position and on further rearward movement to pass from engagement with said breech block.

24. In an automatic firearm, the combination of a casing, a recoiling barrel and barrel extension, and a lock frame mounted

for reciprocatory movement in said casing, means for returning said recoiling members to their forward position after recoil, means for holding said lock frame in rearward position while said barrel and barrel extension are returning to forward position, a breech block mounted on said extension for transverse movement to open and close the breech of said barrel, breech block actuating means mounted on said lock frame and adapted to engage and move said breech block to its open and closed positions on the movements of said lock frame, whereby said actuating means will engage and move said breech block to its open position on the recoil of said recoiling members, will pass from engagement with said breech block when said lock frame is being held in its rearward position and will again engage and move said breech block to its breech closing position on the subsequent forward movement of the lock frame.

25. In an automatic firearm, the combination of a breech casing, a recoiling barrel and barrel extension mounted for reciprocatory movement therein, a recoiling lock frame mounted for reciprocatory movement at the rear of said barrel, means for returning said recoiling members to their forward position after recoil, means for holding said lock frame in rearward position while said barrel and barrel extension are returning to forward position, a breech block mounted for transverse movement on the barrel extension, an actuating lever mounted on said lock frame adapted to engage and move said breech block to open and close the breech of said barrel on the reciprocatory movements of said lock frame, and means to guide said lever, whereby said lever will engage and move said block to its open position during the recoil of said recoiling members, will pass from engagement with said breech block while said lock frame is being held in its rearward position and will again engage and move said breech block to breech closing position on the subsequent forward movement of said lock frame.

26. In an automatic firearm, the combination of a breech casing, a recoiling barrel and barrel extension mounted therein, means for returning said members to their forward position after recoil, a breech block mounted for transverse movement on said barrel extension to open and close the breech of the barrel, a member at the rear of said barrel also mounted for longitudinal reciprocatory movement and carrying an extractor adapted to engage the rim of the cartridge in the barrel chamber, a lever carried by said member and having its forward arm adapted to operatively engage said breech block, means for rocking said lever to move the breech block to open posi-

tion during the recoil of said member, means for keeping the said member in rearward position on return movement of said barrel and barrel extension, thereby withdrawing the empty shell from the barrel chamber, the engagement between the lever and the breech block permitting the separation of these members, and means for guiding said lever during the forward movement of said reciprocating member, whereby said lever is again brought into engagement with said breech block and cam means for swinging said lever during the final forward movement of said member to move the breech block to its breech closing position.

27. In an automatic firearm, the combination of a breech casing, a barrel supported therein, a reciprocating member mounted at the rear of said barrel, a breech block movable transversely of the axis of the barrel to open and close the breech of the same, a slot in said breech block, a breech block actuating lever pivotally mounted on said member and having a stud at its forward end for engagement in said slot, and means for rocking said lever during the movements of said reciprocating member, whereby the engagement of said stud in said slot effects the opening and closing movements of said breech block.

28. In an automatic firearm, the combination of a breech casing, a barrel and barrel extension mounted for longitudinal movement therein, a reciprocating frame member, a breech block mounted for transverse movement on the barrel extension, a slot in said block, a breech block actuating lever pivotally mounted on said frame member and having a stud at its forward end to engage in said slot, means to rock said lever on the movements of said frame member whereby said stud will engage in said slot and move the breech block into breech closing position on the forward movement of said frame, and will move said block to breech opening position on the rearward movement thereof.

29. In an automatic firearm, a breech casing, a barrel and barrel extension mounted for longitudinal movement therein, a recoiling lock frame, a breech block mounted for vertical movement on said barrel extension, a slot in said block, means for raising said breech block into breech closing position comprising an actuating lever having a stud at its forward end to engage in said slot, means for engaging said stud in said slot on the forward movement of said lock frame, means for rocking the forward end of said lever upwardly on the further forward movement of said lock frame to move said block into breech closing position, a locking shoulder adjacent said stud, and a lost motion connection between

said stud and slot whereby on the final upward movement of the forward end of said lever said stud will disengage from said slot and said shoulder will engage and hold said block in its raised position.

30. In an automatic firearm, a breech casing, a barrel and barrel extension mounted therein, a recoiling member at the rear of said barrel, a breech block slidably mounted in said barrel extension, a lever for engaging said breech block and sliding it into and out of breech closing position, and means for actuating said lever on the forward and rearward movements of said member, comprising a cam plate having cam surfaces mounted on the breech casing and studs on said lever to engage said cam plate and cam surfaces.

31. In an automatic firearm, a breech casing, a barrel and barrel extension mounted for longitudinal movement therein, a reciprocating lock frame mounted at the rear of the barrel, a breech block mounted for vertical sliding movement on the barrel extension, a breech block actuating lever operatively connected with said frame, cam means for rocking said lever during the movement of said frame, and a spring pressed strut for actuating said lever to move said block to its breech closing position and to hold said block thus positioned pending discharge.

32. In an automatic firearm, the combination of a breech casing, a recoiling barrel and barrel extension mounted therein, a breech block movable transversely to the axis of the barrel to open and close the breech of the same, a recoiling lock frame, a breech block actuating lever mounted on said lock frame, and cams on said casing co-operating with said lever in the movement of said lock frame to automatically effect the opening and closing movements of the breech block, said cams permitting the manual operation of said lever to open and close the breech of the barrel, when desired, without moving said barrel and barrel extension.

33. In an automatic firearm, the combination of a breech casing, a barrel and barrel extension mounted for longitudinal reciprocatory movement therein, a breech block mounted in said barrel extension for movement transversely to the axis of said barrel to open and close the breech of the same, a member in rear of said barrel also mounted for longitudinal reciprocatory movement in said casing, a two-armed lever pivoted to said member and having its forward arm adapted to engage with said breech block, a cam on said breech casing, a lateral projection on the forward arm of said lever adapted to cooperate with said cam to start the breech block toward its open position during the first part of the recoil of said barrel and

barrel extension and said member, a cam plate having a cam groove in rear of said cam, and a lateral projection on the rear arm of said lever arranged to enter the forward end of said cam groove before the lateral projection on said forward arm has left its cooperating cam, whereby, during the further recoil, the breech block is moved to its full open position.

34. In an automatic firearm, the combination of a recoiling barrel and barrel extension, a transversely movable breech block for opening and closing the breech of the barrel, and means whereby said breech block is automatically moved to its open position during the recoil of said members, said means permitting the manual operation of said breech block when the barrel and barrel extension are in their forward positions.

35. In an automatic firearm, a breech casing, a barrel and barrel extension mounted for longitudinal movement therein, a recoiling member, a breech block mounted for transverse movement on the barrel extension, means actuated by the forward and rearward movements of said member to move said breech block into and out of breech closing position, a stop on said barrel extension to limit the breech opening movement of the breech block, and means to yieldingly hold said breech block at the limit of said movement.

36. In an automatic firearm, the combination of a breech casing, a barrel and barrel extension mounted for longitudinal movement therein, a reciprocating lock frame mounted at the rear of said barrel, a breech block mounted for transverse movement on the barrel extension, a locking groove in the forward face of said lock frame and a corresponding locking rib on said breech block, adapted, when the lock frame moves forwardly to firing position and the breech block moves to close the breech, to engage in said groove and lock together said lock frame and breech block.

37. In an automatic firearm, the combination of a breech casing, a barrel and barrel extension mounted for longitudinal movement therein, a reciprocating lock frame mounted at the rear of said barrel, a breech block mounted for transverse movement on said barrel extension, means to absorb the recoil of said barrel and barrel extension following discharge and to return the same to forward position, a reaction spring for said lock frame, means to hold said lock frame in rearward position following its recoil while said barrel and barrel extension return to forward position, a spring pressed hammer mounted on the lock frame, means actuated by the recoil of said lock frame to cock said hammer, means which, on the first portion of the recoil of the lock frame, engage the breech block and move it from

breech closing position, said breech block actuating means disengaging from said block when said lock frame is held rearwardly and the barrel and barrel extension return to forward position and engaging said block and raising it to breech closing position on the subsequent forward movement of the lock frame, means to eject the spent cartridge on the separation of said actuating means from said block, means to feed a new cartridge into the gun between the lock frame and the barrel while the lock frame is being held rearwardly, whereby, when the lock frame is released for forward movement said new cartridge will be inserted into the breech of the barrel and the breech block will be moved to breech closing position, and trigger operated means to release the hammer to fire said cartridge.

38. In an automatic firearm, the combination of a breech casing, a barrel and barrel extension and a lock frame mounted for reciprocatory movement in said casing, means for returning said members to their forward position after recoil, a breech block mounted for transverse movement to open and close the breech of said barrel, an extractor mounted on said lock frame for withdrawing an empty shell from the barrel chamber, means operatively connected with said lock frame for moving said breech block to its open position during the recoil of said recoiling members, means for holding said lock frame in rearward position while said barrel is returning to its forward position whereby the cartridge shell is extracted from the barrel chamber, and cooperating means on said barrel extension and said lock frame for ejecting said shell from said casing.

39. In an automatic firearm, the combination of a breech casing, a barrel and barrel extension mounted for longitudinal movement therein, a reciprocating lock frame mounted at the rear of said barrel, a breech block mounted for transverse movement on the barrel extension, breech block actuating means mounted on said lock frame, and cam means on the breech casing adapted to engage said actuating means to move the breech block from breech closing position on the recoil of said lock frame and to move said breech block to breech closing position on the forward movement of said frame following recoil, said lock frame being adapted to be manually retracted, said actuating and cam means cooperating on manual retraction of the lock frame to move said breech block from breech closing position.

40. In an automatic firearm, the combination of a breech casing, a barrel and barrel extension mounted for longitudinal movement therein, a lug projecting from said barrel extension having a hole therethrough

counterbored at each end, a recuperator for said barrel having a piston with its rear end seated in said hole, nuts adapted to screw on said rod and into the counterbores of said hole at front and rear thereof to secure said piston rod therein, a breech block mounted for sliding movement on said barrel extension and a stop detachably mounted on said lug to limit movement of said block and to lock said nuts from rotation.

41. In an automatic firearm, the combination of a breech casing, a barrel and barrel extension mounted for longitudinal movement therein, said barrel extension having a depending lug at its forward end, a recuperator having a piston with its rear end detachably mounted in said lug, a breech block mounted for vertical sliding movement on said barrel extension, means for automatically raising and lowering said breech block to close and open the breech, a stop on said lug to limit the downward movement of said breech block and means on said lug to engage and yieldingly hold said breech block in its lowered position.

42. In an automatic firearm, the combination of a breech casing, a barrel and barrel extension mounted for longitudinal movement therein, a reciprocating lock frame mounted at the rear of said barrel, a breech block mounted for vertical sliding movement in said barrel extension and having a slot therein, means to raise and lower said block comprising an actuating lever pivotally mounted on said frame and having a forward arm with two branches, studs on one branch to engage in said slot on the forward movement and recoil of said frame, cam surfaces on said casing, and studs on the second of said forward branches and on the rearward arm of said lever respectively, to engage said cam surfaces whereby on the forward movement of said lock frame said first-named stud is guided into said slot and said lever is then rocked to raise said block and whereby on the recoil of said frame and barrel and barrel extension said lever is first rocked to engage said first-named stud in said slot and lower said breech block and means to hold said frame in rearward position while said barrel and barrel extension return to forward position whereby said studs will be withdrawn from said slot in said block and said lock frame and lever will be completely disengaged from said breech block and barrel extension.

43. In an automatic firearm, the combination of a recoiling barrel and barrel extension, a recoiling lock frame at the rear of said barrel, a breech block mounted for transverse movement on said extension, an element mounted on said frame to engage and move said block to and from breech closing position on the forward and rearward movements of said frame, means to hold

said frame in rearward position following recoil while said barrel and barrel extension move to forward position, said breech block actuating element being adapted to be
 5 disengaged from said breech block when said barrel and barrel extension return to forward position whereby said lock frame becomes completely disengaged from said barrel and barrel extension and breech block.

10 44. In an automatic firearm, the combination of a breech casing, a barrel mounted therein, a reciprocating lock frame mounted at the rear of said barrel, a hammer mounted thereon, a hammer spring, a breech block
 15 mounted for sliding movement in a plane transverse to the axis of said barrel, a firing pin mounted in said block, actuating means rendered operative on the rearward and forward movements of said lock frame to move
 20 the breech block out of and into breech closing position, means actuated by said breech block actuating means on the recoil of said lock frame to move said hammer rearwardly against its spring, a sear to hold said hammer
 25 in its rearward position, and means to release the hammer to fire a shot.

45. In an automatic firearm, the combination of a breech casing, a barrel mounted for longitudinal movement therein, a reciprocating
 30 lock frame, a breech block mounted for sliding movement in a plane transverse to the axis of the barrel, a breech block actuating lever mounted on the lock frame, a spring actuated firing member mounted
 35 on the lock frame, a sear, a cocking lever, and means whereby said cocking lever is actuated by said breech block actuating lever on the recoil of said lock frame to move the firing member to cocked position.

40 46. In an automatic firearm, the combination of a barrel, a reciprocating lock frame, a breech block movable transversely of the axis of the barrel to open and close the breech of the same, a breech block actuating
 45 lever mounted on the lock frame, a spring actuated firing member carried by said lock frame, a sear for holding said member in cocked position, and means whereby, on the recoil of said lock frame, said breech block actuating lever moves said
 50 firing member to its cocked position.

55 47. In an automatic firearm, the combination of a barrel, a reciprocating lock frame, a breech block movable transversely of the axis of the barrel to open and close the breech of the same, a breech block actuating
 60 element to engage and move said block to close and open the breech on the forward and rearward movements, respectively, of said frame, a spring actuated firing member carried by said frame, means to hold the same in cocked position, and means, whereby, on the recoil of said frame, said breech
 65 block actuating element moves said firing member to its cocked position.

70 48. In an automatic firearm, the combination of a breech casing, a barrel mounted therein, a lock frame mounted for longitudinal movement therein, a breech block mounted for sliding movement in a plane
 75 transverse to the axis of the barrel, a breech block actuating lever mounted on the lock frame, means whereby said lever slides said breech block into and out of breech closing position on the forward and rearward move-
 80 ments of said lock frame, a hammer carried by said lock frame, a hammer spring, a sear, a cocking lever pivotally mounted on the lock frame with one end engaging the hammer and the other end in position to be
 85 engaged by said actuating lever when it operates to move the breech block from breech closing position, whereby on the recoil of said lock frame said hammer will be cocked.

90 49. In an automatic firearm, the combination of a barrel, a breech block movable transversely of the axis of said barrel to open and close the breech of said barrel, a firing pin carried by said breech block, a
 95 longitudinally movable member carrying a hammer, and means on said member for moving said breech block to closed position upon the forward movement of said member, whereby the hammer and the firing pin will
 100 be in their proper cooperative relation only when the breech block is in its fully closed position.

105 50. In an automatic firearm, the combination of a breech casing, a barrel, a breech block movable transversely of the barrel axis to open and close the breech of said barrel, a firing pin carried by said block, a
 110 longitudinally reciprocating lock frame, a hammer carried by said lock frame for cooperation with said firing pin, a trigger mounted on said breech casing and connecting means between said trigger and said
 115 hammer for releasing the same for firing movement and means whereby said connecting means are operative only when the lock frame is in its forward firing position.

120 51. In a firearm, the combination of a barrel, a reciprocating member, a breech block, a breech block actuator for operatively connecting said member and said breech
 125 block, a firing member carried by said reciprocating member, a sear for holding said firing member in cocked position, means for automatically cocking said firing member on the recoil of said reciprocating member, a
 130 trigger, connecting means between said trigger and said sear which are inoperative to move the sear to release the firing member when the breech block is in its breech opening position, and means to render said connecting means operative only when the breech block is in full breech closing position, said means comprising an element interposed between said actuator and said con-

necting means and adapted to be engaged and held in its operative position by said actuator when the same has moved the breech block to breech closing position.

5 52. In a firearm, the combination of a barrel, a reciprocating lock frame, a breech block mounted for movement in a plane transverse to the axis of the barrel to open and close the breech of said barrel, a hammer carried by the lock frame, a hammer spring, a sear for holding said hammer in cocked position, means whereby said hammer is moved to cocked position on the recoil of said lock frame, a trigger, connecting means between the sear and the trigger, and means operative on the closing of the breech to render said connecting means operative, whereby said sear cannot be released from operative engagement with the hammer until the breech block is in its full breech closing position.

15 53. In a firearm, the combination of a barrel, a reciprocating member, a breech block, a breech block actuator, firing mechanism mounted on said reciprocating member, a sear, means to automatically cock the firing mechanism on the recoil of said member, a trigger, connecting means between said trigger and said sear which is inoperative to actuate said sear to release the firing mechanism, and means to render said connecting means operative only when the breech block is in full breech closing position, said means comprising an element interposed between said actuator and said connecting means and adapted to be engaged and held by the said actuator when said actuator has moved said breech block to breech closing position and when so held to render said connecting means operative.

20 54. In an automatic firearm, the combination of a reciprocating member, a breech block, firing mechanism mounted on said reciprocating member, a sear, means to automatically cock said firing mechanism on the recoil of said member, a trigger, connecting means between said trigger and said sear which is inoperative to actuate said sear to release the firing mechanism, and means to render said connecting means operative only when the breech block is in full breech closing position, said means comprising a pivoted trip lever in position to render said connecting means operative on the closing of the breech.

25 55. In an automatic firearm, the combination of a barrel, a breech block movable to open and close the breech of said barrel, firing mechanism, a sear for holding said mechanism in cocked condition, means for actuating said sear to release said mechanism comprising a trigger, connecting means between said trigger and said sear which are normally inoperative to actuate the sear, and means operative on the closing

of the breech to render said connecting means operative, whereby premature firing is avoided and firing may be effected automatically by the closing of the breech if said trigger is held back.

30 56. In an automatic firearm, the combination of a barrel, a breech block movable to open and close the breech of the barrel, an actuator for moving said breech block a firing pin carried by said block, a hammer for cooperation with said firing pin, a sear for holding said hammer in cocked condition, and means for actuating said sear to release the hammer comprising a trigger, connecting means between said trigger and said sear which is normally inoperative, and a trip lever which renders said connecting means operative and which is automatically actuated by said breech block actuator when the latter moves the block to its breech closing position, whereby premature firing is avoided, and firing will be effected automatically by the final breech closing movement of the actuator if the trigger is held back.

35 57. In an automatic firearm, the combination of a barrel, a breech closing member, a firing member, a mainspring therefor, a sear for holding said firing member in cocked condition, means for actuating said sear to release said firing member comprising a trip lever and a trigger lever having a connecting lever pivoted thereto, said connecting lever having a cooperative relation both with the sear and with the trip lever, and means for causing said trip lever to operatively engage said connecting lever when said member closes the breech of said breech closing barrel, as and for the purpose described.

40 58. In an automatic firearm, the combination of a firing member, a mainspring therefor, a sear for holding said member in cocked condition, a trigger lever, a connecting lever pivoted thereto and having one arm adapted to engage said sear, and a trip lever adapted to engage the other arm of said connecting lever, as and for the purpose described.

45 59. In a firearm, the combination of a reciprocating lock frame, a breech block, breech block actuating means operative on the rearward and forward movements of the lock frame, a firing member mounted on the lock frame, a main spring, a sear, a trigger, a two-armed trigger lever, connecting means between said trigger and said trigger lever which engage and actuate one arm of said lever when the lock frame is in its forward firing position and the trigger is actuated, a connector pivoted on the other arm of said trigger lever, said connector having a free arm and a sear engaging arm, a trip lever having one arm overlying the free arm of said connector and another arm posi-

70

75

80

85

90

95

100

105

110

115

120

125

130

tioned to be engaged and held by the breech block actuating means when it has moved the breech block to full breech closing position, whereby said sear engaging arm of
 5 said connector can actuate the sear to release the firing member only when the breech is closed and the lock frame is in forward position.

60. In an automatic firearm, the combination of a breech casing, a lock frame mounted for longitudinal movement therein, a breech block, a firing member mounted on said lock frame, a sear, a sear spring, a trigger, a trigger lever, means for actuating said trigger lever by said trigger, a trigger lever connector, and a trip lever positioned to operatively engage said connector on the closing of the breech, as and for the purpose described.

61. In an automatic firearm, a breech casing comprising side plates each having inwardly projecting flanges at the top and the bottom, a removable rear plate to close the rear of the casing having a sliding engagement with said side plates, a reciprocating lock frame, a reaction spring therefor, a hole in said rear plate, a projection at the rear end of the guide rod of said spring adapted to seat in said hole, a guiding plate on said guide rod forward of and adjacent to said projection, said guiding plate resting against said rear plate and engaging a side flange of the breech casing to prevent withdrawal of said rear plate until said projection is withdrawn from said hole.

62. In an automatic firearm, a breech casing comprising side plates each having inwardly projecting flanges at the top and the bottom, a top cover plate secured thereto, a removable rear plate having a sliding engagement with said side plates, a reciprocating member, a reaction spring therefor, a hole in said rear plate, a projection at the rear end of the guide rod of said spring adapted to project into said hole, a guiding plate at the rear end of said guide rod, said guiding plate resting against said rear plate with its rear face, and engaging with its top, bottom and side edges the flanges and the inner face of the adjacent side plate, as and for the purpose described.

63. In an automatic firearm, the combination of a breech casing having a transversely removable rear plate, a member mounted for longitudinal reciprocation in said casing, a reaction spring for returning said member to forward position, a guide rod for said spring having a positioning means adapted to rest against the top, one side and the bottom of said casing, and a rearward projection on said rod adapted to enter a hole in said rear plate and adapted to be held therein by the tension of said spring, whereby said rear plate and the

reaction spring guide rod are held in their assembled relation. 65

64. In an automatic firearm, the combination of a breech casing having a rear plate slidable transversely for mounting and dismounting it, a member mounted for longitudinal reciprocating movement in said casing, a reaction spring for returning said member to forward position, a guide rod for said spring having a projection at its rear end normally extending into a hole in said rear plate, and a lateral projection on said rod adjacent said rear plate, said lateral projection cooperating with a wall of said casing to keep said rear plate in assembled position. 70 75 80

65. In an automatic firearm, a breech casing, a lock frame mounted for longitudinal movement therein, a reaction spring therefor, a buffer secured at the rear of said casing comprising a plunger mounted for limited longitudinal movement in the path of said lock frame and having an inclined rear face, a brake block mounted for vertical sliding movement and having a similarly inclined front face to engage said rear face of the plunger and an inclined top face, a second brake block mounted for vertical movement on said first brake block having an inclined face to engage the top face thereof, a coil spring acting on the second brake block, a housing for said plunger, blocks and spring, as and for the purpose described. 85 90 95

66. In an automatic firearm, the combination of a breech casing having a removable rear plate, a recoiling member mounted for reciprocating longitudinal movement, a buffer secured in the rear portion of said casing for absorbing any excess of energy of recoil of said member, said buffer comprising a casing enclosing a longitudinally movable metal block adapted to be struck by said member, said block being formed at its rear end with an incline adapted to engage a corresponding incline, a transversely movable brass block which is formed with another incline adapted to engage a corresponding incline on a fiber block movable transversely to said first mentioned block and resilient means backing said last mentioned block, whereby a blow on the longitudinally movable block will tend to compress the resilient means and force the said blocks against the bottom and side of the buffer casing to exert a braking action. 100 105 110 115 120

67. In an automatic firearm, a breech casing having side plates with inwardly projecting flanges at top and bottom, a rear plate to close the rear end of said casing and having a sliding engagement with the rear ends of said side plates, a recoiling member mounted for longitudinal reciprocating movement in said casing, a reaction 125

spring therefor, a guide plate on the end of the guide rod of said spring which engages the rear plate at one side thereof and the adjacent side plate, a buffer for said reciprocating member positioned beside said guide plate and having a casing of which the said rear plate forms the rear end, said buffer comprising a plunger and one or more brake blocks and a spring, as and for the purpose described.

68. In an automatic firearm, a breech casing having a transverse cartridge feed opening and a transverse channel, a barrel having its breech normally forward of said opening, a feed plate adapted to hold a plurality of cartridges comprising a substantially flat plate having a plurality of seats, each seat adapted to engage the rim of a cartridge and hold the same from longitudinal displacement therefrom, resilient means to engage said cartridge and hold the same from vertical displacement from said seat, means to automatically feed said plate step-by-step through said channel to successively position said cartridges centrally of the casing, means to move the resilient means from engaging the cartridge thus positioned, means to withdraw said cartridge from its seat and means to move it into position to be injected into the chamber of said barrel.

69. In an automatic firearm, a breech casing having a transverse cartridge opening, and a cartridge feed plate adapted to hold a plurality of cartridges to be fed through said opening, comprising a substantially flat plate having a plurality of seats, each seat having overhanging flanges at its edges adapted to receive the rim of a cartridge head and hold said cartridge against longitudinal displacement therefrom, and resilient means projecting into each said seat to engage said rim, whereby a cartridge can be secured in said seat and withdrawn therefrom by moving said resilient means from said seat.

70. In an automatic firearm, a breech casing having a cartridge feed opening and means to hold a plurality of cartridges and to feed the same successively through said opening, said means comprising a substantially flat feed plate having a plurality of seats, each seat having overhanging flanges at its edges adapted to receive the rim of a cartridge head, a plurality of spring catches having stop projections adapted to project through slots into said seats, as and for the purpose described.

71. In an automatic firearm, a breech casing having a cartridge feed opening, means to hold a plurality of cartridges and feed them successively into said casing, said means comprising a substantially flat feed plate having a plurality of seats in its front

face, each seat formed at its edges with overhanging flanges adapted to receive the rim of a cartridge head, slots in said seats adjacent the open mouths thereof, spring catches secured to the rear face of said plate and having stop projections extending through said slots and into said recesses, as and for the purpose described.

72. In an automatic firearm, a breech casing having a transverse cartridge feed opening and a cartridge feed plate channel, a cartridge feed plate comprising a substantially flat plate having a plurality of seats, each seat adapted to engage the head of a cartridge, slots in said seats, spring catches having stop projections projecting through said slots, cam faces on said catches and a cam surface in said channel adapted to co-operate with said cam faces as the feed plate is fed therethrough, as and for the purpose described.

73. In an automatic firearm having recoiling mechanism, a breech casing having a transverse cartridge feed opening, a transverse channel, a cartridge feed plate insertable in said channel, said feed plate comprising a substantially flat plate, means thereon comprising seats having side walls for preventing movement of the cartridges in a direction lengthwise of said plate to removably hold a plurality of cartridges in substantial parallelism with the longitudinal axis of the firearm, said plate having a rearwardly projecting flange provided with spaced shoulders, and means actuated by the recoiling mechanism of the firearm to engage one of said shoulders on each recoil movement of said recoiling mechanism and thereby feed said feed plate step by step transversely through said channel.

74. An automatic firearm having a transverse feed channel, an elongated cartridge feed plate adapted to be fed through the channel edgewise, said plate having a plurality of cartridge seats in its forward face to receive the heads of cartridges, and resilient catches for holding said cartridges in said plate, and a cam in said feed channel co-operating with said catches to withdraw the same to release the cartridges successively as they approach the center line of the firearm.

75. In an automatic firearm, the combination of a breech casing having a transverse feed channel, a cartridge feed plate having seats adapted to receive the heads of cartridges and hold said cartridges against endwise movement therein, catches for positively holding said cartridges in said plate, said plate being insertable in said feed channel, means for automatically moving said plate transversely through said channel to successively position said cartridges centrally of said casing, and means

for automatically and successively releasing said catches and withdrawing a cartridge thus positioned from said plate.

76. A cartridge holder for automatic fire-
 5 arms, comprising a substantially flat elongated plate having on one side thereof a plurality of seats, each seat adapted to engage the head of a cartridge and hold the same from longitudinal displacement there-
 10 from, and resilient means to engage said cartridge heads and hold the same against displacement from said seats.

77. A cartridge holder for automatic fire-
 15 arms, comprising a substantially flat elongated plate having on one side thereof a plurality of seats opening in a direction at right angles to the length of the plate, each seat having overhanging flanges at its edges adapted to receive the heads of cartridges
 20 and resilient spring catches on the other side of said plate, said catches having stop projections adapted to project through slots into said seats to retain said cartridges therein.

78. A cartridge holder for automatic fire-
 25 arms, comprising a substantially flat elongated plate having on its front side a plurality of seats opening in a direction at right angles to the length of the plate, each
 30 seat formed at its edges with overhanging flanges adapted to receive the rim of a cartridge head, slots in said seats, spring catches secured to the rear face of said plate and having stop projections extending through
 35 said slots and into said seats, as and for the purpose described.

79. In an automatic firearm, the combination of a breech casing, a feed box mounted on said casing and having a transverse
 40 feed channel therethrough, hinged doors for closing the ends of said feed channel when the same is not in use, and a pivotally mounted top cover for said feed box, one of said doors being hinged to said top cover.

80. In an automatic firearm, the combination of a frame having a hinged top cover and a transverse feed opening through
 45 said frame, a feed plate carrying cartridges and adapted to be moved through said opening, means to automatically move said plate step by step through said opening, spaced
 50 notches on said plate, a stop pawl mounted on the underside of said top cover to engage said notches and prevent retrograde movement of said plate, whereby, when the
 55 top cover is lifted said stop pawl will be automatically removed from its engagement with the plate to permit manual withdrawal of said plate when desired.

81. In an automatic firearm, the combination of a recoiling member, a casing, a
 60 transverse feed channel therein, a cartridge feed plate adapted to hold a plurality of cartridges and insertable in said channel,

spaced notches on said plate forming shoulders, a feed pawl actuated by the movement
 65 of the recoiling member and adapted to engage in said notches to feed said plate step-by-step through said channel, additional notches adjacent said shoulders to weaken
 70 the same, as and for the purpose described.

82. In an automatic firearm, the combination of a breech casing having a transverse
 75 feed channel, a recoiling member in said breech casing, a feed plate carrying a plurality of cartridges insertable into said feed channel, and means for moving said plate transversely step by step to successively bring the cartridges into position for
 80 insertion into the barrel chamber, said means comprising a lever projecting into the path of a stud on said recoiling member, and a second lever swinging in a plane substantially at right angles to said first
 85 lever and carrying a feed pawl at one end thereof, said first named lever carrying a swivel stud engaging loosely in a corresponding groove in said second lever whereby to actuate the same.

83. In an automatic firearm, the combination of a breech casing carrying a feed
 90 box on the top thereof, said feed box having a transverse feed channel therethrough, a holder carrying cartridges and adapted to be moved through said channel, and means for automatically moving said holder transversely with a step by step movement, said
 95 means comprising a feed lever having its lower free end depending into said breech casing, a reciprocating member having a stud for engaging said lever alternately on its opposite sides, and a spring for swinging
 100 said lever back from its extreme positions when released by said stud near the limit of movement of said reciprocating member in each direction, and connecting means between said feed lever and said holder.

84. In an automatic firearm, the combination of a frame having a transverse feed
 110 channel, a cartridge feed plate adapted to be moved through said channel, and means for automatically moving said plate transversely through said channel by a step by step movement, said means comprising a reciprocating member, a feed lever with its
 115 free end positioned in the path of said member, means for yieldingly limiting the movement of said lever when engaged by said member, whereby, on the limit of movement of said lever in either direction, said member will pass from engagement therewith
 120 and said lever will be positioned to be engaged by said member on the reverse movement thereof, and means connecting said lever with said plate, as and for the purpose described.

85. In an automatic firearm, the combi-

nation of a frame having a transverse feed channel, a feed plate adapted to hold a plurality of cartridges and to move through said channel, and means to automatically move said plate step by step through said channel, said means comprising a reciprocating member having a stud, a feed lever with its free end positioned in the path of said stud, a spring which yieldingly engages said lever at the desired limit of movement thereof in each direction whereby the stud will pass from engagement therewith and the lever will be positioned to be engaged and actuated by the stud on the reverse movement of said stud, and a feed pawl actuated by said lever, as and for the purpose described.

86. In an automatic firearm, the combination of a breech casing having a feed box, a transverse feed channel therein, a cartridge feed plate insertable in said channel, and means for automatically moving said plate through said channel by a step by step movement, said means comprising a feed pawl, a feed pawl lever, a feed lever, a feed lever spring and a reciprocating member having a stud adapted to engage said feed lever, as and for the purpose described.

87. In an automatic firearm, the combination of a breech casing having a feed box, a feed channel therein, a cartridge feed plate insertable in said channel, and means to automatically move said plate through said channel, said means comprising a reciprocating member having a projecting stud thereon, a feed lever pivotally mounted in said box and having its free end depending into the breech casing and positioned in the path of said stud, a spring positioned to yieldingly engage the lever at the desired limit of movement thereof in each direction, whereby when said lever is engaged by said spring said stud in its continued movement will pass from engagement with said lever and said lever will be positioned to be engaged by said stud on the reverse movement thereof, and means actuated by said lever to engage and move said plate step by step, as and for the purpose described.

88. In an automatic firearm, the combination of a recoiling barrel, a reciprocating member mounted at the rear of said barrel and adapted to recoil with said barrel after the firing of a shot, means for returning said barrel to its forward position following recoil, means for holding said member in a rearward position while said barrel returns to its forward position, means for positively feeding a cartridge between said member and the rear end of said barrel while said member is in its rearward position, and mechanism rendered operative by the said feeding of the cartridge

to release said holding means, whereby said member moves to its forward position and pushes the cartridge into the barrel chamber.

89. In an automatic firearm, the combination of a recoiling barrel, a recoiling member mounted at the rear of said barrel, means to return said recoiling parts to their forward positions following recoil, means for holding said recoiling member in a rearward position while said barrel returns to its forward position, said means comprising a dog positioned in the path of a part of said recoiling member and adapted to engage said part and hold said member from forward movement, means for positively feeding a cartridge between said recoiling member and said barrel while said recoiling member is in its rearward position, and means rendered operative by the said feeding of a cartridge to release said dog from engagement with said recoiling member when a cartridge has been positioned between said member and said barrel, whereby said member will move forwardly and push said cartridge into the chamber of said barrel.

90. In an automatic firearm, the combination of a barrel, a recoiling member mounted at the rear of said barrel and adapted on its forward movement to push a cartridge into the chamber of said barrel, means for holding said member in a rearward position following its recoil, means for positively positioning a cartridge in substantial alignment with the axis of said barrel and between said member and said barrel, and means actuated by said positioning of the cartridge to release said holding means whereby said member moves forwardly and pushes said cartridge into said chamber.

91. In an automatic firearm, the combination of a barrel, a recoiling member at the rear of said barrel, means for holding said member in a rearward position following recoil, means for positively positioning a cartridge in substantial alignment with the axis of said barrel and between said member and said barrel, means actuated by said cartridge to release said holding means when said cartridge is thus positioned whereby said member moves forwardly and pushes said cartridge into the chamber of said barrel.

92. In an automatic firearm, the combination of a barrel, a recoiling member at the rear of said barrel, means for holding said member in a rearward position following recoil, said means comprising a pivotally mounted dog adapted to engage a shoulder on said member, means to positively position a cartridge between said member and said barrel in substantial align-

ment with the axis of said barrel, and means actuated by said positioning of said cartridge to move said dog from engagement with said shoulder, whereby said member is released to move forwardly and push said cartridge into the chamber of said barrel.

93. In an automatic firearm, the combination of a breech casing, a barrel, a recoiling member at the rear of said barrel, means for feeding a cartridge into said casing, means for holding said member in a rearward position following recoil, means for positively moving said cartridge into substantial alignment with the axis of said barrel and between said member and said barrel while said member is held retracted, and means whereby said holding means is released when said cartridge is thus positioned thereby allowing said member to move forwardly and push said cartridge into the chamber of said barrel.

94. In an automatic firearm, the combination of a breech casing, a barrel, a recoiling member at the rear of said barrel, means for feeding a cartridge into said casing, means for holding said member in a rearward position following recoil and moving said cartridge into substantial alignment with the axis of said barrel and between said member and said barrel while said member is held retracted, said moving and holding means comprising a pivoted spring actuated cartridge carrier to engage said cartridge, a dog pivoted to said carrier and adapted to engage said member, and means for locking said cartridge carrier with said spring under compression adapted to be released from locking engagement with said carrier by said feeding of said cartridge, whereby said spring will actuate said carrier to move said cartridge and release said dog to permit the recoiling member to move forwardly and push the cartridge into the chamber of said barrel.

95. In an automatic firearm, the combination of a breech casing, a barrel, a recoiling member at the rear of said barrel, means for feeding a cartridge into said casing, means for holding said member in a rearward position following recoil, means for moving said cartridge into substantial alignment with the axis of said barrel between said member and said barrel, said holding and moving means comprising a pivoted cartridge carrier and a dog pivoted thereto adapted to engage said member to hold it retracted, a spring between said carrier and said dog adapted to swing said carrier into engagement with said cartridge to move it toward the barrel axis and simultaneously to release said dog from engagement with said member, and means for locking said carrier with said spring under

compression adapted to be released by the feeding of said cartridge into said casing.

96. In an automatic firearm, the combination of a breech casing, a barrel, a recoiling member at the rear of said barrel, means for feeding a cartridge into said casing, means for holding said member in a rearward position following recoil, means for moving said cartridge into substantial alignment with the axis of said barrel between said member and said barrel, said holding and moving means comprising a pivoted cartridge carrier and a dog pivoted thereto adapted to engage said member to hold it retracted, a spring between said carrier and said dog adapted to swing said carrier into engagement with said cartridge to move it toward the barrel axis and simultaneously to release said dog from engagements with said member and a latch for locking said carrier with the spring under compression, said latch being positioned to be tripped by said cartridge when the same is fed into said casing.

97. In an automatic firearm, the combination of a breech casing, a barrel, a recoiling member at the rear of said barrel adapted to push a cartridge into the chamber of said barrel, a transverse feed channel positioned outside the path of travel of said member, a feed plate adapted to hold a plurality of cartridges and to be inserted in said channel, means to automatically feed said plate step by step through said channel, means to disengage a cartridge from said plate and position it in substantial alignment with the axis of said barrel whereby it may be pushed into the chamber of said barrel by said member, said means comprising a cam surface adapted to engage a cartridge being fed through said casing and move the same from its position in said plate and a carrier adjacent said cartridge, and means to actuate said carrier to engage said cartridge and move it into substantial alignment with the chamber of said barrel.

98. In an automatic firearm, the combination of a breech casing, a barrel, a reciprocating member at the rear of said barrel, means to hold said member in a rearward position following recoil, a transverse feed channel in said casing, means to feed a plurality of cartridges one by one into said casing, said means comprising a feed plate adapted to hold a plurality of cartridges and insertable into said channel, means to lock said cartridges in said plate, means to move said plate step by step through said channel, means to disengage said cartridges one by one from said plate and position them in substantial alignment with the axis of said barrel while said member is held retracted, said means comprising an element adapted to actuate said locking

means to unlock a cartridge fed into said casing, a cam surface positioned in the path of travel of said cartridges adapted to engage said unlocked cartridge and move it from its position in said plate, a carrier adapted to engage said cartridge and cooperate with said cam to move said cartridge into substantial alignment with the axis of said barrel and between said retracted member and said barrel, and means whereby said member will be released when said cartridge is thus positioned whereby said member will move forwardly and push said cartridge into the chamber of said barrel.

99. In an automatic firearm, the combination of a breech casing, a barrel, a recoiling member adapted on its forward movement to push a cartridge into the chamber of said barrel, means for holding said member in a rearward position following recoil until a cartridge is fed into position for insertion into said barrel, said means comprising a pivoted cartridge engaging member, a dog pivoted thereto and adapted to engage said member to hold it retracted, means to actuate said cartridge-engaging member into engagement with a cartridge to move it toward the barrel axis and simultaneously to release said dog from engagement with said member, and a latch for locking said cartridge-engaging member with said spring under compression, said latch being arranged to be automatically tripped by a cartridge on its movement into the breech casing.

100. In an automatic firearm, the combination of a breech casing, a barrel, a recoiling member adapted on its forward movement to push a cartridge into the chamber of said barrel, means for holding said member in a rearward position following recoil until a cartridge is fed into position for insertion into said barrel, said means comprising a pivoted cartridge-engaging member, a dog pivoted thereto and adapted to engage said member to hold it retracted, a spring between said cartridge-engaging member and said dog tending to swing said cartridge-engaging member into engagement with a cartridge to move it toward the barrel axis and simultaneously to release said dog from engagement with said member, and a latch for locking said cartridge-engaging member with said spring under compression, said latch being arranged to be automatically tripped by the cartridge on its movement into the breech casing.

101. In an automatic firearm, the combination of a breech casing, a barrel, a recoiling member adapted on its forward movement to a push a cartridge into the chamber of said barrel, means for feeding

a cartridge into said casing outside the plane of movement of said member, means for holding said member in a rearward position and moving a cartridge into position between said member and said barrel chamber, said means comprising a pivoted cartridge carrier having a forwardly projecting arm adjacent said cartridge, a dog pivoted thereto adapted to engage a shoulder on said member and having a rearwardly projecting tail piece, a spring mounted between said carrier and said dog, said dog when said recoiling member is in its forward position projecting into the path of said member, a latch for locking said cartridge carrier against movement arranged to be automatically tipped by the cartridge being fed into the casing, whereby when said member is retracted it will engage said dog and lift it against the compression of said spring and said dog will engage said shoulder with its tail member engaging the top of said member and whereby when a cartridge is fed into the casing said latch will be disengaged from said carrier which will be actuated by said spring to engage said cartridge to move it into a position between said recoiling member and said barrel chamber and simultaneously said tail piece will press on the top of said member and lift said dog from engagement with said shoulder, permitting said member to move forwardly and push said cartridge into the chamber of said barrel.

102. In an automatic firearm, the combination of a breech casing, a recoiling barrel, a recoiling member at the rear of said barrel, means to feed a cartridge into the casing outside the plane of said recoiling member, means to hold said member in a rearward position following recoil, a member to engage said cartridge and move it to a position between said barrel and said recoiling member when said member is being held in its rearward position, means to actuate said cartridge-engaging member and means to positively hold said member from cartridge-engaging movement until the barrel has returned to forward position following recoil.

103. In an automatic firearm, the combination of a breech casing, a recoiling barrel, a recoiling member at the rear of said barrel, means for returning said barrel and said member following recoil, means for holding said member in rearward position while the barrel returns forward, means for positively positioning a cartridge between said barrel and said member when said member is being held in rearward position, said holding means being releasable in the movement of said cartridge positioning means, means to actuate said positioning means, and means to positively hold said

positioning means against cartridge positioning movement until the barrel has returned forward.

104. In an automatic firearm, the combination of a breech casing, a recoiling barrel and barrel extension, a recoiling member at the rear of said barrel, means to feed a cartridge into the casing outside the plane of said members, means to hold said member in a rearward position following recoil, a pivoted member to engage said cartridge and position it in substantial alignment with the axis of said barrel while said member is held rearwardly, means to actuate said cartridge-engaging member and means to hold said member from cartridge-engaging movement until said barrel and barrel extension have returned to forward position, said holding means comprising a projection on said cartridge-engaging member which overlies and is held from movement by said barrel extension except when said barrel extension is in its forward position.

105. In an automatic firearm, the combination of a breech casing, a recoiling barrel and barrel extension, said barrel extension having a rearwardly extending arm, a recoiling member at the rear of said barrel, means to feed a cartridge into the casing outside the plane of said recoiling member, means to hold said frame in a rearward position following recoil, a pivoted member to engage said cartridge and position it in substantial alignment with the axis of said barrel while said recoiling member is held rearwardly, means to actuate said cartridge-engaging member and means to hold said member from cartridge-engaging movement until said barrel and barrel extension have returned to forward position, said holding means comprising a projection on said member which overlies and is held from movement by said arm of said barrel extension except when said barrel extension is in its forward position.

106. In an automatic firearm, the combination of a recoiling barrel and barrel extension, said extension having a rearwardly extending arm, a recoiling member at the rear of said barrel, means to engage and hold said member in a rearward position following recoil, means to position a cartridge between said barrel and said member when said member is held in its rearward position, actuating means to automatically release said holding means from said member when said cartridge is thus positioned, and means to prevent a release of said member until said barrel and barrel extension have returned to forward position, said means comprising a projection on said actuating means overlying and held from movement by said arm of said barrel exten-

sion except when said extension is in its forward position.

107. In an automatic firearm, the combination of a recoiling barrel, a recoiling member at the rear of said barrel adapted on its forward movement to push a cartridge into the chamber of said barrel, means for holding said member in a rearward position following recoil until a cartridge is fed into position for insertion into said barrel chamber, said means comprising a pivoted cartridge-engaging member, a dog pivoted thereto and adapted to engage said recoiling member to hold it retracted, means to swing said cartridge-engaging member into engagement with a cartridge to move it toward the barrel axis and simultaneously to release said dog from holding engagement with said recoiling member, and means which prevent said movements of said cartridge-engaging member and said dog unless the barrel is in its forward position.

108. In an automatic firearm, the combination of a recoiling barrel and barrel extension, said barrel extension having a rearwardly projecting arm, a recoiling member adapted on its forward movement to push a cartridge into the chamber of said barrel, means for holding said member in a rearward position following recoil until a cartridge is fed into position for insertion into said barrel chamber, said means comprising a pivoted cartridge carrier, a dog pivoted thereto and adapted to engage said member to hold it retracted, means to swing said carrier into engagement with a cartridge to move it toward the barrel axis and simultaneously to release said dog from holding engagement with said member, and means which prevent said movements of said carrier and dog unless said barrel and barrel extension are in their forward position, said means comprising a projection on the hub of said carrier which overlies and is held from movement by said arm of said barrel extension except when said barrel extension is in its forward position.

109. In an automatic firearm, the combination of a recoiling barrel and barrel extension, said extension having a rearwardly projecting arm, a recoiling member adapted on its forward movement to push a cartridge into the chamber of said barrel, a cam surface on said member, means to hold said member in a rearward position following recoil, a pivoted cartridge carrier adapted to engage a cartridge and move it toward the barrel axis while said member is retracted, a projection on said carrier which overlies and is held from movement by said arm of said barrel extension except when said barrel extension is in its forward position, and which lies in the path of said cam surface when said carrier has swung on its pivot

to position said cartridge, whereby when the member moves forwardly to insert said cartridge into said barrel chamber said cam surface will engage said projection and swing said carrier back to position to engage a new cartridge.

110. In an automatic firearm, the combination of a barrel, a recoiling member, a breech casing having a transverse cartridge feed opening outside the path of said recoiling member, a cartridge holder adapted to hold a plurality of cartridges, means to feed said holder and cartridges transversely through said opening and into said casing, means to hold said member retracted following recoil, means to simultaneously disengage a cartridge from said holder and move it toward the axis of said barrel and between the chamber of said barrel and said member when said member is retracted, and means to release said member, whereby said member may be moved forwardly to engage said cartridge and push it into the chamber of said barrel.

111. In an automatic firearm, the combination of a breech casing, a barrel, a recoiling cartridge pushing member mounted at the rear of said barrel, a cartridge holder adapted to hold a plurality of cartridges, means to feed said holder step by step transversely into said casing above the path of said recoiling member whereby said cartridges will be successively positioned centrally of said casing, means to hold said recoiling member retracted following recoil, means to successively disengage said cartridges from said holder and simultaneously to depress a cartridge thus disengaged into position to be inserted into the chamber of said barrel, said depressing means comprising a pivoted carrier having an arm overlying said cartridge and means to swing said arm rendered operative on the removal of said cartridge from said holder, and means to release said recoiling member on the depression of said cartridge, whereby said member will move forwardly and push said cartridge into the chamber of said barrel.

112. In an automatic firearm, the combination of a breech casing having an opening through its top, a barrel, a longitudinally movable cartridge pushing member mounted in said casing at the rear of said barrel, means for holding said member rearward following its retraction, a feed box mounted on said casing to cover said opening, means for feeding cartridges transversely into said box to position them successively above said opening, means to move a cartridge thus positioned through said opening into position to be inserted into the chamber of said barrel operative while said member is held rearward, and means to release said member when said cartridge is thus positioned,

whereby said member may be moved forwardly and push said cartridge into said chamber.

113. In an automatic firearm, the combination of a barrel, a breech casing having an opening through its top, a feed box mounted on said casing to cover said opening, means for feeding cartridges transversely into said box to position them successively above said opening, means to move a cartridge thus positioned into position to be inserted into the chamber of said barrel, said means comprising a cartridge carrier pivotally mounted in said box and having an arm overlying said cartridge, and means to swing said arm to engage said cartridge and move it through said opening and into said casing.

114. In an automatic firearm, the combination of a barrel, a breech casing having an opening through its top, a feed box mounted on said casing to cover said opening, means for feeding cartridges transversely into said box to position them successively above said opening, a cartridge carrier mounted in said box having an arm overlying a cartridge thus positioned, means for actuating said carrier to engage a cartridge thus positioned and move it through said opening into position to be inserted into the chamber of said barrel, means to support said cartridge in said position and means to push said cartridge into said chamber.

115. In an automatic firearm, the combination of a barrel, a breech casing having an opening through its top, a feed box mounted on said casing to cover said opening, means for feeding cartridges into said box to successively position them above said opening, means to move a cartridge thus positioned through said opening into position to be inserted into the chamber of said barrel, means to support said cartridge in said position and means to push said cartridge into said chamber.

116. In an automatic firearm, the combination of a barrel, a barrel extension having rearwardly extending bifurcated arms, means for feeding cartridges transversely into said firearm to successively position them above the opening between said arms, means to move a cartridge thus positioned into the space between said arms and in position to be inserted into the chamber of said barrel, means for supporting said cartridge in said position and a member mounted for reciprocation between said arms to engage and push said cartridge into said chamber.

117. In an automatic firearm, the combination of a recoiling barrel, means to feed cartridges transversely into said firearm to successively position them in the central plane thereof and above the path of said recoiling barrel, a cartridge engaging member to move a cartridge thus positioned into po-

sition to be inserted into the chamber of said barrel, actuating means for said member rendered operative by the feeding of a cartridge into said central position, and means to push said cartridge into said chamber.

118. In an automatic firearm, the combination of a barrel, a breech casing having an opening through its top, means to feed cartridges into the firearm to successively position them above said opening, means to move a cartridge thus positioned through said opening into position to be inserted into the chamber of said barrel, means located in the path of said cartridge in such lowering movement to support said cartridge thus positioned for such insertion, and means to insert said cartridge into said chamber.

119. In an automatic firearm, the combination of a barrel, a breech casing having an opening through its top, means to feed cartridges into the firearm to successively position them above said opening, means to move a cartridge thus positioned through said opening into a downwardly inclined position with its nose in position to enter the chamber of said barrel, means located in the path of said cartridge in its lowering movement to support said cartridge in said position, and means to engage the rear end of said cartridge and push it into said chamber, said supporting means permitting the rear end of said cartridge to drop as said cartridge is moved forwardly.

120. In an automatic firearm, the combination of a breech casing having a cartridge feed opening through its top, a barrel means for feeding cartridges through said opening, a lever for supporting a cartridge thus fed through said opening in a forwardly and downwardly inclined position with its nose in position to enter the chamber of said barrel, means for supporting said lever to hold the cartridge in such a position, a member reciprocally mounted in said casing for engaging the base of the cartridge to push it into the barrel chamber, and means on said member for rendering said supporting means inoperative on the initial forward movement of said cartridge thereby permitting the base of the cartridge to drop to bring the axis of the cartridge into substantial alignment with the barrel axis, in which position it is fully inserted into said chamber by the further forward movement of said member.

121. In an automatic firearm, the combination of a breech casing having an opening through its top, a barrel and barrel extension, said extension having a rearwardly extending arm, means to feed cartridges successively through said opening into a forwardly and downwardly inclined position with the nose in position to enter the barrel chamber, a guide lever pivotally mounted

on said arm to underlie and support a cartridge thus positioned, a stop mounted on said arm and positioned to support said guide lever, a reciprocating cartridge pushing member adapted on its forward movement to engage the base of a cartridge thus positioned, and having means to engage said stop, whereby on the initial forward movement of said cartridge by said member, said stop will be disengaged from said guide lever and said guide lever will move downwardly permitting the base of the cartridge to drop to bring the axis of the cartridge into substantial alignment with the barrel axis in which position it will continue its movement into the barrel chamber on the further forward movement of said reciprocating element.

122. In an automatic firearm, the combination of a breech casing having an opening through its top, a barrel and barrel extension, said extension having a rearwardly extending arm, means to feed cartridges successively through said opening into a forwardly and downwardly inclined position with the nose in position to enter the barrel chamber, a guide lever pivotally mounted on said arm to underlie and support a cartridge thus positioned, a stop lever pivotally mounted on said arm and positioned to support said guide lever, a reciprocating cartridge pushing member adapted on its forward movement to engage the base of a cartridge thus positioned, and having a cam surface to engage said stop lever, whereby on the initial forward movement of said cartridge by said member said stop lever will be disengaged from said guide lever and said guide lever will move downwardly permitting the base of the cartridge to drop to bring the axis of the cartridge into substantial alignment with the barrel axis, in which position it will continue its movement into the barrel chamber on the further forward movement of said reciprocating member.

123. In an automatic firearm, the combination of a breech casing having an opening through its top, a barrel and barrel extension, said extension having a rearwardly extending arm, means to feed cartridges successively through said opening into a forwardly and downwardly inclined position with the nose of a cartridge in position to enter the barrel chamber, a guide lever pivotally mounted on said arm and projecting into the path of said cartridge to engage and support the cartridge thus positioned, a stop lever pivotally mounted adjacent its center on the bottom face of said arm and having its forward end adapted to underly and support said guide lever, a reciprocating cartridge pushing element adapted on its forward movement to engage the base of a cartridge thus positioned and having means to

engage and swing inwardly the rear end of said stop lever whereby the forward end of said stop lever will be withdrawn from engagement with said guide lever permitting
 5 said guide lever and cartridge to move downwardly to bring the axis of the cartridge into substantial alignment with the barrel axis, in which position it will continue its movement into the barrel chamber
 10 on the further forward movement of said reciprocating element.

124. In an automatic firearm, the combination of a breech casing having an opening through its top, a barrel and barrel extension, said extension having a rearwardly extending arm, means to feed cartridges successively through said opening, a guide lever pivotally mounted on said arm and projecting into the path of said cartridge and adapted to support said cartridge in its downward movement, a stop lever pivotally and yieldingly mounted on the bottom face of said arm with its front end adapted to engage and yieldingly stop said guide lever and cartridge with the nose of said cartridge in position to be inserted into the barrel chamber, a reciprocating cartridge pushing member adapted on its forward movement to engage the base of a cartridge thus positioned and having an element adapted to engage and swing said stop lever from engagement with said guide lever, and a projection on the rear end of said stop lever adapted to project into the path of said guide lever, whereby on the initial forward movement of said reciprocating element the nose of the cartridge will enter said chamber, the stop lever will be swung away from engagement with the guide lever, said guide lever and cartridge will be lowered to bring the axis of the cartridge into substantial alignment with the axis of the barrel and said guide lever will be stopped from further movement by yielding engagement with said projection, and on further forward movement of said reciprocating member the cartridge will be inserted fully into said chamber.

125. In an automatic firearm, the combination of a breech casing having an opening, a recoiling barrel and barrel extension, a member mounted for reciprocating movement at the rear of said barrel, a shell extractor mounted thereon adapted to engage the rim of a shell, means to hold said member retracted during the forward movement of said barrel and barrel extension following recoil whereby the empty shell will be withdrawn from said barrel, a shell ejector comprising a lever mounted on said barrel extension and adapted to overlie said withdrawn shell during said forward movement, and means carried by said retracted member adapted to engage said lever when thus positioned and rotate it on its pivot to

strike said shell and positively eject it through said opening.

126. In an automatic firearm, the combination of a breech casing having an opening through its bottom, a recoiling barrel and barrel extension, a reciprocating member mounted for longitudinal movement at the rear of said barrel, a shell extractor mounted thereon, means for holding said member retracted during the forward movement of said barrel and barrel extension following recoil whereby the empty shell will be withdrawn from said barrel, a shell ejector comprising a two armed lever pivotally mounted on said barrel extension and adapted to have one arm thereof overlie said withdrawn shell during the forward movement of said barrel extension, cam surfaces on the other arm thereof, a stud on said retracted member adapted to engage one of said cam surfaces when said lever is in said overlying position to rotate the same to strike said shell and positively eject it through said opening and on the subsequent forward movement of said member to engage the other cam surface and return said ejector to its original position.

127. In an automatic firearm, the combination of a breech casing having an opening through its top, a barrel, a reciprocating cartridge pushing member at the rear of said barrel, means to hold said member rearward following its retraction, means to feed cartridges successively through said top opening in the casing into position to be inserted into the barrel chamber while said member is retracted, a member to support the forward portion of said cartridge when thus positioned, and a cartridge ejector adapted to support the rear portion of said cartridge.

128. In an automatic firearm, the combination of a breech casing having an opening through its top, a recoiling barrel, a reciprocating cartridge pushing member at the rear of said barrel, means to hold said member rearward following retraction, means to return said barrel to forward position following recoil, means to feed cartridges successively through said top opening in the casing into position to be inserted into the barrel chamber while said member is retracted, a member to support the forward portion of said cartridge when thus positioned, a cartridge ejector adapted to support the rear portion of said cartridge, and a shell extractor on said cartridge pushing member to engage the rim of said cartridge.

129. In an automatic firearm, the combination of a breech casing, a barrel mounted for recoil movement therein, a breech block movable transversely of the axis of said barrel to open and close the breech of same, a longitudinally reciprocable member for withdrawing the shell from the barrel

chamber and inserting a new cartridge therein when said breech block is in breech opening position.

130. In an automatic firearm, the combination of a recoiling barrel, a breech block movable transversely of the axis of said barrel to open and close the breech of the same, a member mounted for longitudinal reciprocation at the rear of said barrel, said member carrying an extractor for extracting empty shells from the barrel chamber, a breech block actuating lever mounted on said member and adapted to engage said block, means whereby said lever actuates said block to open said breech during the recoil of said barrel and said member, means for returning said barrel to forward position and means for simultaneously holding said member retracted, whereby the empty shell is withdrawn from the barrel chamber during said return movement of the barrel.

131. In an automatic firearm, the combination of a recoiling barrel, a breech block movable transversely of the axis of said barrel to open and close the breech thereof, a member mounted for longitudinal reciprocation at the rear of said barrel, means mounted thereon to engage and move said block, a cartridge engaging and pushing element on said member which projects forwardly of and overlies the path of movement of said block when said member is in its forward position, means for holding said member retracted following recoil, means for feeding a cartridge between said retracted member and said barrel, means for releasing and returning said member to forward position whereby said element will engage said cartridge and push it into the chamber of the barrel and simultaneously through said block engaging means move said block to breech closing position, and means to lock together said barrel, block and reciprocating member when the breech is closed and said member is in its forward position.

132. In an automatic firearm, the combination of a barrel, a breech block movable transversely of the axis of said barrel to open and close the breech thereof, a recoiling member at the rear of said barrel, a cartridge pushing element and a shell extractor mounted thereon and each projecting forwardly thereof and adapted when said member is in its forward position to extend forwardly of and without the path of movement of said breech block, breech block actuating means rendered operative in the rearward and forward movements of said member to open and close the breech, means for holding said member retracted following recoil, means for feeding a cartridge between said retracted member and the barrel chamber, means for releasing said

member for forward movement whereby said pushing element will engage and push said cartridge into said chamber and said extractor will engage the rim of said cartridge and said block will be moved to close the breech, and means for locking together said barrel, block and recoiling member when said block is in breech closing position and said member is in forward position.

133. In an automatic firearm, the combination of a barrel, a breech block movable transversely of the axis of the barrel to open and close the breech thereof, a recoiling member mounted for longitudinal reciprocation at the rear of said barrel, an element mounted on said recoiling member adapted to engage and move said block to and from breech closing position on the forward and rearward movements of said member, and means to actuate said element to move said block which buffers the forward and rearward movements of said recoiling member.

134. In an automatic firearm, the combination of a breech casing, a barrel, a breech block movable transversely of the axis of the barrel to open and close the breech thereof, a recoiling member mounted for longitudinal reciprocation at the rear of said barrel, a breech block actuating lever mounted on said member to engage and move said block, and cam means on said casing which cooperate with said lever to move said block to breech opening and breech closing positions on the rearward and forward movements of said recoiling member and which buffer said movements of said member.

135. In an automatic firearm, the combination of a barrel and barrel extension, a breech block slidably mounted on said extension for movement transverse to the axis of said barrel, a member mounted for longitudinal reciprocating movement at the rear of said barrel and adapted to engage and push a cartridge into the barrel chamber on its forward movement, a lever mounted on said member to engage and move said block to breech closing position on the forward movement of said member, and cooperating elements on said block and said member which come into locking engagement on the breech closing movement of said block to lock together said block and said member.

136. In an automatic firearm, a breech casing having a transverse cartridge feed opening, a feed plate adapted to hold a plurality of cartridges and to be fed through said opening, means for positively holding said cartridges in said plate, said means comprising seats which positively secure said cartridges against endwise movement and holding means which hold said cartridges against transverse movement, means to automatically feed said plate to successively position said cartridges within said casing, and

means to successively release said holding means from holding engagement with a cartridge thus positioned.

137. In an automatic firearm, a breech casing having a transverse cartridge feed opening, a feed plate adapted to hold a plurality of cartridges and to be fed through said opening, means for holding said cartridges in said plate, said means comprising seats which positively secure said cartridges against endwise movement and holding means which hold said cartridges against transverse movement, means to automatically feed the plate to successively position said cartridges within said casing, means to release said holding means from holding engagement with a cartridge thus positioned, and means to disengage said cartridge from said plate and insert it into the chamber of the barrel.

138. An automatic firearm having a transverse feed channel, an elongated cartridge feed plate adapted to be fed through said channel edgewise, said plate having a plurality of cartridge seats in its forward face to receive the heads of cartridges and hold said cartridges against endwise movement, means for positively holding said cartridges in said seats, yielding means for keeping said holding means in operative position, and means in said feed channel for withdrawing said holding means from their operative position to release the cartridges successively as they approach the vertical central plane of the firearm.

139. A cartridge holder for automatic firearms comprising a substantially flat elongated plate adapted to be fed edgewise through a feed channel on the firearm with which it is to be used, said plate having on its front side a plurality of seats for receiving the cartridge heads and hold the cartridges against endwise movement, said seats having openings to admit or discharge cartridges in a direction at right angles to the length of the plate, and means for retaining said cartridges against movement through said openings, said means being adapted to be moved to inoperative position for placing the cartridges into their seats or removing them therefrom.

140. A cartridge holder for automatic firearms comprising a substantially flat elongated plate adapted to be fed edgewise through a feed channel on the firearm with which it is to be used, a plurality of seats on the front face of said plate for receiving the heads of cartridges and preventing endwise movement of said cartridges, said seats opening transversely of the length of said plate to receive or discharge cartridges, and means for positively holding the cartridges in said plate against discharging movement, said means being yieldingly held in operative position.

141. In an automatic firearm, the combination of a casing, a barrel and barrel extension supported therein, a reciprocating member mounted at the rear of said barrel, a breech block mounted on said barrel extension and having transverse sliding movement thereon to open and close the breech of said barrel, and means for imparting said movement to said breech block comprising a lever carried by said member and adapted to engage said breech block and cams on said casing adapted to co-operate with said lever.

142. In an automatic firearm, the combination of a casing, a barrel supported therein, a reciprocating member mounted at the rear of said barrel, a breech block movable transversely to the axis of the barrel to open and close the breech of the same, means actuated by the movements of said reciprocating member to move the breech block into and out of breech closing position, and an extractor carried by said reciprocating member for extracting a shell from the barrel when the breech block has been moved to its open position.

143. In an automatic firearm, a barrel, a breech block movable transversely to open and close the breech of the barrel, a member mounted for longitudinal movement and adapted to push a cartridge into the barrel chamber in its forward movement, and a common means for manually moving said breech block to its open position and said member to a rearward position.

144. In an automatic firearm, a barrel, a breech block movable transversely of the axis of said barrel to open and close the breech of the same, a member mounted for longitudinal movement and adapted to push a cartridge into the barrel chamber in its forward movement, and a lever for manually moving said breech block to its open position and said member to a rearward position.

145. In an automatic firearm, a barrel, a breech block movable transversely of the axis of said barrel to open and close the breech of the same, a member mounted for longitudinal movement and adapted to push a cartridge into the barrel chamber in its forward movement, and an element carried by said member for moving said breech block to its open position and said member to a rearward position by the manual retraction of said element.

146. In an automatic firearm, the combination of a breech casing, a barrel and barrel extension mounted for longitudinal movement therein, a longitudinally movable element adapted to push a cartridge into the barrel chamber in the forward movement of said element, a breech block movable transversely of the axis of said barrel to open and close the breech of the same,

means whereby the breech block is automatically moved to its open position on movement of said longitudinally movable members, and a common means for manually moving said breech block to its open position and said element to a rearward position when the barrel and barrel extension are in their forward position.

147. In an automatic firearm, the combination of a casing, a barrel supported therein, a reciprocating member mounted at the rear of said barrel and carrying a firing element, a breech block movable transversely of the axis of the barrel to open and close the breech of the same, a firing element carried by said breech block and adapted to co-operate with said first-named firing element, and means actuated by the movements of said reciprocating member to move the breech block into and out of breech closing position.

148. In an automatic firearm, the combination of a casing, a barrel supported therein, a reciprocating member mounted at the rear of said barrel and carrying a hammer, a breech block movable transversely of the axis of the barrel to open and close the breech of the same and a firing pin carried by said breech block and adapted to be struck by said hammer.

149. In an automatic firearm, the combination of a casing, a barrel supported therein, a reciprocating member mounted at the rear of said barrel and adapted to push a cartridge into the barrel on its forward movement, a hammer carried by said member, a breech block movable transversely of the axis of the barrel to open and close the breech of the same, and a firing pin carried by said breech block and adapted to be struck by said hammer when the breech block is in its operative position closing the breech and the reciprocating member is in its forward position.

150. In an automatic firearm, the combination of a barrel, a breech block movable transversely to the axis of the barrel to open and close the breech thereof, a firing member, a sear for holding said member in cocked position, means for actuating said sear from holding engagement with said firing member which is normally inoperative, and means operative on the closing of the breech to render said actuating means operative whereby premature firing is avoided and firing may be effected automatically by the closing of the breech.

151. In an automatic firearm, the combination of a recoiling barrel, a breech block movable transversely to the axis of said barrel to open and close the breech of the same, means for moving said breech block and means for bringing a cartridge into position for insertion into the barrel on the forward

movement of said barrel, said means comprising a feeder carrying a plurality of cartridges and adapted to be moved transversely to the axis of said barrel.

152. In an automatic firearm, the combination of a barrel, a breech block movable transversely to the axis of said barrel to open and close the breech of the same, means for moving said breech block, means for positioning a cartridge in substantial alignment with the axis of said barrel, said means comprising a transversely movable feeder carrying a plurality of cartridges and mechanism for advancing said feeder step-by-step and a member for positively removing the cartridge from said feeder and bringing it into said position, and means for automatically moving the cartridge so positioned into the chamber of the barrel.

153. In an automatic firearm, the combination, of a casing, a barrel supported therein, a breech block mounted for movement transversely to the axis of said barrel to open and close the breech of the same, means for automatically pushing a cartridge into the barrel chamber when the breech is open, and means for feeding cartridges successively between said pushing means and the breech of the barrel, said means comprising a transversely movable feeder adapted to carry a plurality of cartridges and mechanism for advancing said feeder step by step.

154. In an automatic firearm, the combination of a casing, a barrel mounted for recoil movement therein, a breech block mounted for movement transversely of the axis of said barrel to open and close the breech of the same, means for feeding cartridges successively into substantial alignment with the bore of the barrel, said means comprising a transversely movable feeder adapted to carry a plurality of cartridges and mechanism actuated by the movements of said barrel for advancing said feeder step by step, and means for automatically pushing the cartridges successively into the barrel chamber.

155. In an automatic firearm, the combination of a breech casing, a barrel supported therein, a breech block mounted for movement transversely to the axis of said barrel to open and close the breech of the same, a transverse feed channel in said casing, a cartridge feed plate insertable in said channel and means for automatically feeding said plate step by step through the feed channel, said means comprising a recoiling member, a feed pawl for feeding said plate and connections between said recoiling member and said feed pawl whereby the pawl is reciprocated to feed said plate.

156. In an automatic firearm, the combination of a breech casing, a barrel sup-

ported therein, a breech block mounted for movement transversely to the axis of said barrel to open and close the breech of the same, a member for carrying a plurality of cartridges adapted to be moved through said feed channel, a reciprocating member, and means operated by said reciprocating member for automatically feeding said cartridge carrying member transversely step by step, said means comprising a lever carrying a feed pawl for engaging said cartridge carrying member, and a second lever for actuating said feed pawl carrying lever and actuated by said reciprocating member.

157. In an automatic firearm, the combination of a barrel, a transversely movable breech block adapted to open or close the breech of the barrel, means for moving said breech block, a recoiling member at the rear of said barrel, means for positioning a cartridge in substantial alignment with the axis of the barrel when said member is in a rearward position, said cartridge positioning means comprising a transversely movable feeder carrying a plurality of cartridges and mechanism for advancing the said feeder step by step, and means for returning said member forwardly to push said cartridge into the chamber of said barrel.

158. In an automatic firearm, the combination of a barrel, a transversely movable breech block adapted to open or close the breech of the barrel, means for moving said breech block comprising a recoiling member at the rear of said barrel, means for holding said member in a rearward position following recoil, means for positioning a cartridge in substantial alignment with the axis of said barrel and between said member and said barrel, and means actuated in so positioning a cartridge to release said holding means whereby said member moves forwardly, pushes said cartridge into the chamber of said barrel and effects the closing movement of said breech block.

159. In an automatic firearm, the combination of a barrel, a barrel extension having rearwardly extending bifurcated arms, means for feeding cartridges to successively position them above the opening between said arms, means to move a cartridge thus positioned into the space between said arms and in position to be inserted into the chamber of the barrel, means including said moving means for supporting said cartridge in said position against any but endwise movement, and a member mounted for reciprocation between said arms to engage and push said cartridge into said chamber.

160. In an automatic firearm, the combination of a breech casing, a barrel, a recoiling member at the rear of said barrel, means for feeding a cartridge into said casing, and means for holding said member in a

rearward position following recoil and moving said cartridge into substantial alignment with the axis of said barrel and between said member and said barrel while said member is held retracted, said moving and holding means comprising a cartridge carrier, actuating means therefor, means for locking said carrier against movement adapted to be released from locking engagement with said carrier by said feeding of said cartridge, a dog adapted to engage said recoiling member and connecting means between said carrier and said dog whereby said carrier is moved by its actuating means to move said cartridge into position to be inserted into the breech of the barrel and to release said dog from engagement with the recoiling member, permitting the same to move forward and push the cartridge into the barrel chamber.

161. In an automatic firearm, a breech casing having a transverse cartridge feed opening, a cartridge holder adapted to hold a plurality of cartridges to be fed through said opening, means for holding said cartridges in said holder, said means comprising downwardly opening seats and resilient means projecting therein to hold said cartridges from vertical displacement in said seats, means to hold said cartridges against endwise movement, means to automatically feed said holder to successively position said cartridges within said breech casing, and means to successively disengage said cartridges and their said holding means whereby said cartridges may be withdrawn downwardly from said seats and inserted into the chamber of the barrel.

162. A cartridge holder for an automatic firearm having a plurality of seats opening downwardly, means adjacent the mouths of said seats, and movable relatively to the holder to normally prevent vertical displacement of said cartridges, and means to hold said cartridges from endwise movement in said holder.

163. In an automatic firearm, a breech casing having a transverse cartridge feed opening, a cartridge holder adapted to hold a plurality of cartridges to be fed through said opening, means for holding said cartridges in said holder, said means comprising downwardly opening seats having non-resilient walls and resilient means projecting therein to hold said cartridges from vertical displacement in said seats, means comprising said walls to hold said cartridges against endwise movement, means to automatically feed said holder to successively position said cartridges within said breech casing, and means to successively disengage said cartridges and their said holding means whereby said cartridges may be withdrawn downwardly from said seats

and inserted into the chamber of the barrel.
 164. A cartridge holder for an automatic
 firearm having a plurality of seats opening
 downwardly and having non-resilient walls,
 5 means adjacent the mouths of said seats
 and movable relatively to the holder to nor-
 mally prevent vertical displacement of said
 cartridges, and means comprising said walls

to hold said cartridges from endwise move-
 ment in said holder. 10

This specification signed and witnessed
 this 8th day of December, A. D. 1923.

JOHN M. BROWNING.

In the presence of —
 K. S. BROWNING,
 LIONEL B. FARR.

Certificate of Correction.

It is hereby certified that in Letters Patent No. 1,525,065, granted February 3, 1925, upon the application of John M. Browning, of Ogden, Utah, for an improvement in "Automatic Firearms," errors appear in the printed specification requiring correction as follows: Page 3, line 1, for the word "of" read *or*; page 6, line 112, for the word "struct" read *strut*; page 8, line 86, strike out the words "providing a shoulder" and insert the same to follow after "17^b" in line 77; page 27, line 103, claim 57, before the word "member" insert the words *breech closing*, and line 104, strike out the words "breech closing"; page 28, line 110, claim 66, strike out the comma and insert the word *on*; page 32, line 84, claim 96, for the word "engagements" read *engagement*; page 33, line 81, claim 101, for the word "tipped" read *tripped*; page 36, line 37, claim 120, after the word "barrel" insert a comma; page 40, line 85, claim 153, after the word "combination" strike out the comma; and that the said Letters Patent should be read with these corrections therein that the same may conform to the record of the case in the Patent Office.

Signed and sealed this 28th day of July, A. D. 1925.

[SEAL.]

KARL FENNING,
 Acting Commissioner of Patents.