

July 22, 1924.

1,502,376

A. G. DAMM

PRODUCTION OF CIPHERS.

Filed April 2, 1920

3 Sheets-Sheet 1

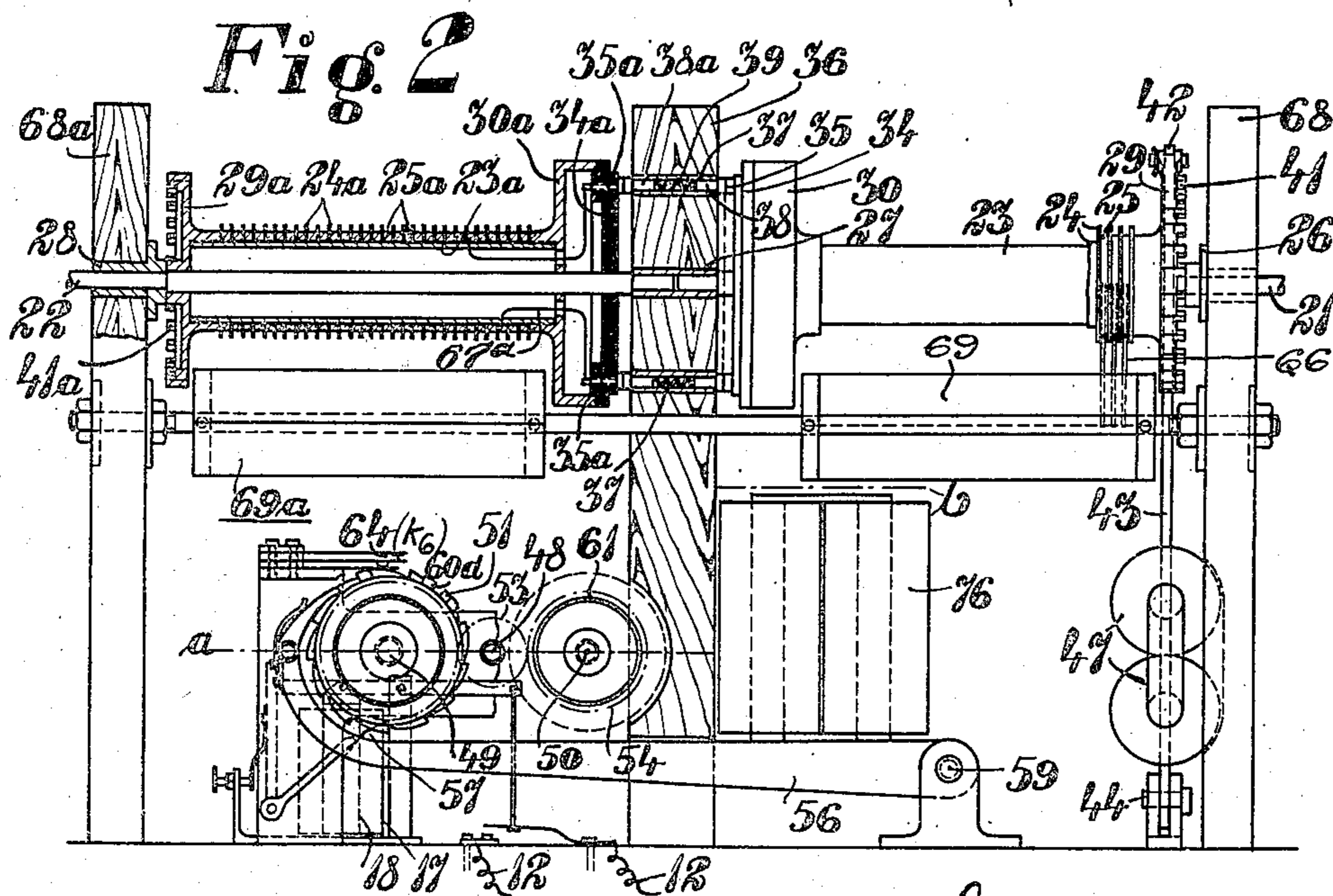
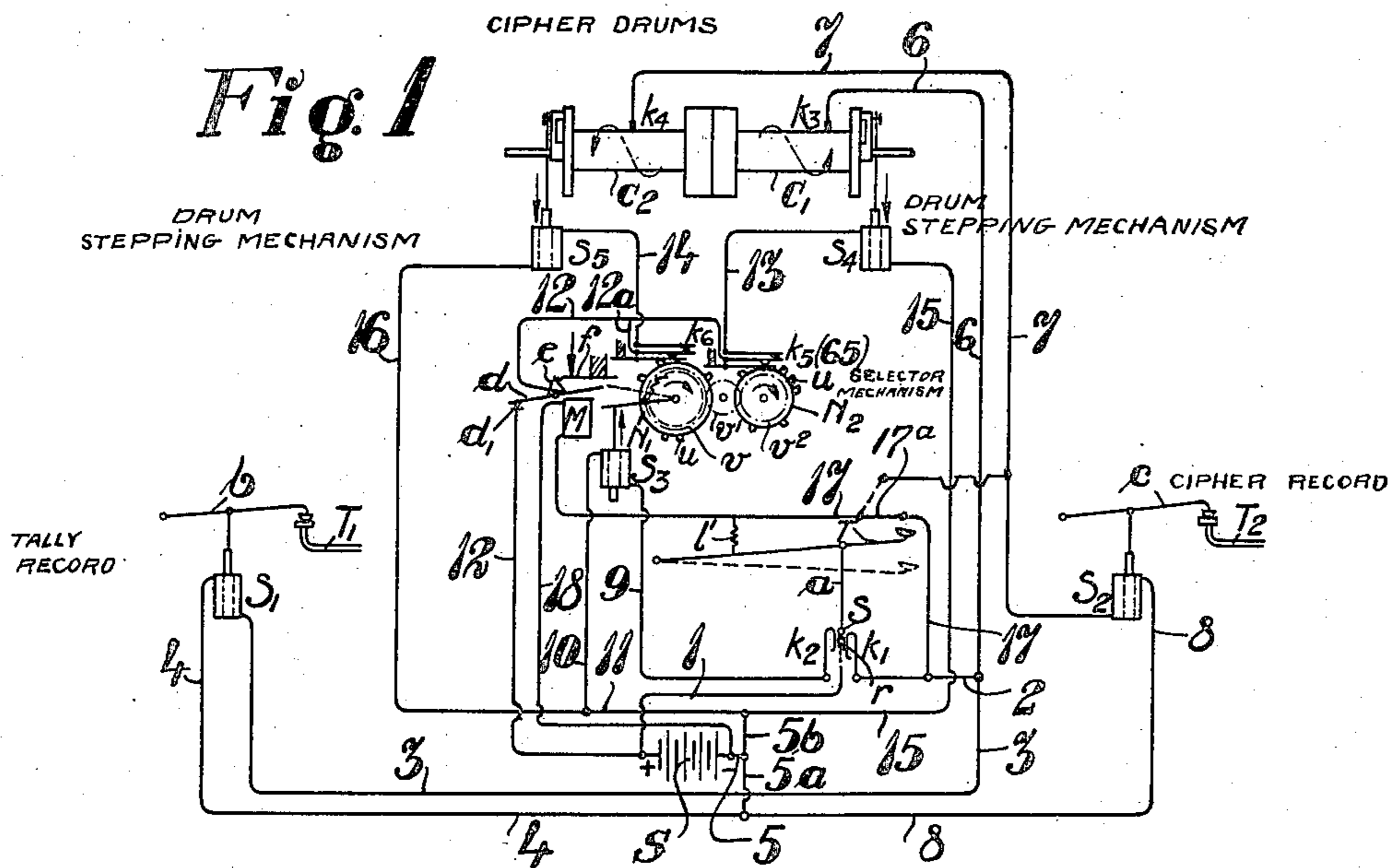

Inventor,
 Aroid Gerhard Damm,
 By *[Signature]* atty.

July 22, 1924.

1,502,376

A. G. DAMM

PRODUCTION OF CIPHERS

Filed April 2, 1920

3 Sheets-Sheet 2

Fig. 3

Fig. 4

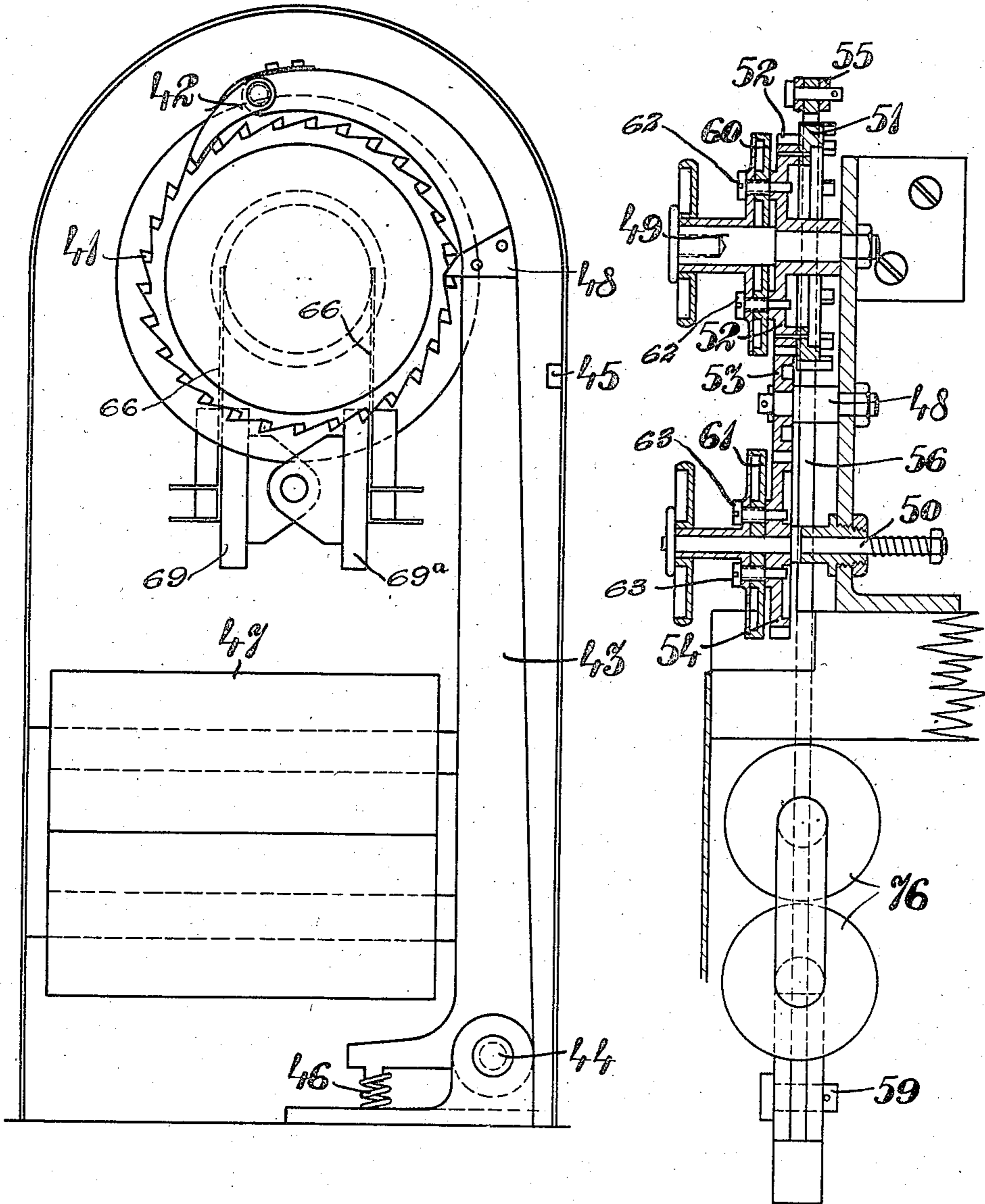

Inventor
Avid Gerhard Damm.
By *[Signature]* Att.

July 22, 1924.

1,502,376

A. G. DAMM

PRODUCTION OF CIPHERS

Filed April 2, 1920

3 Sheets-Sheet 3

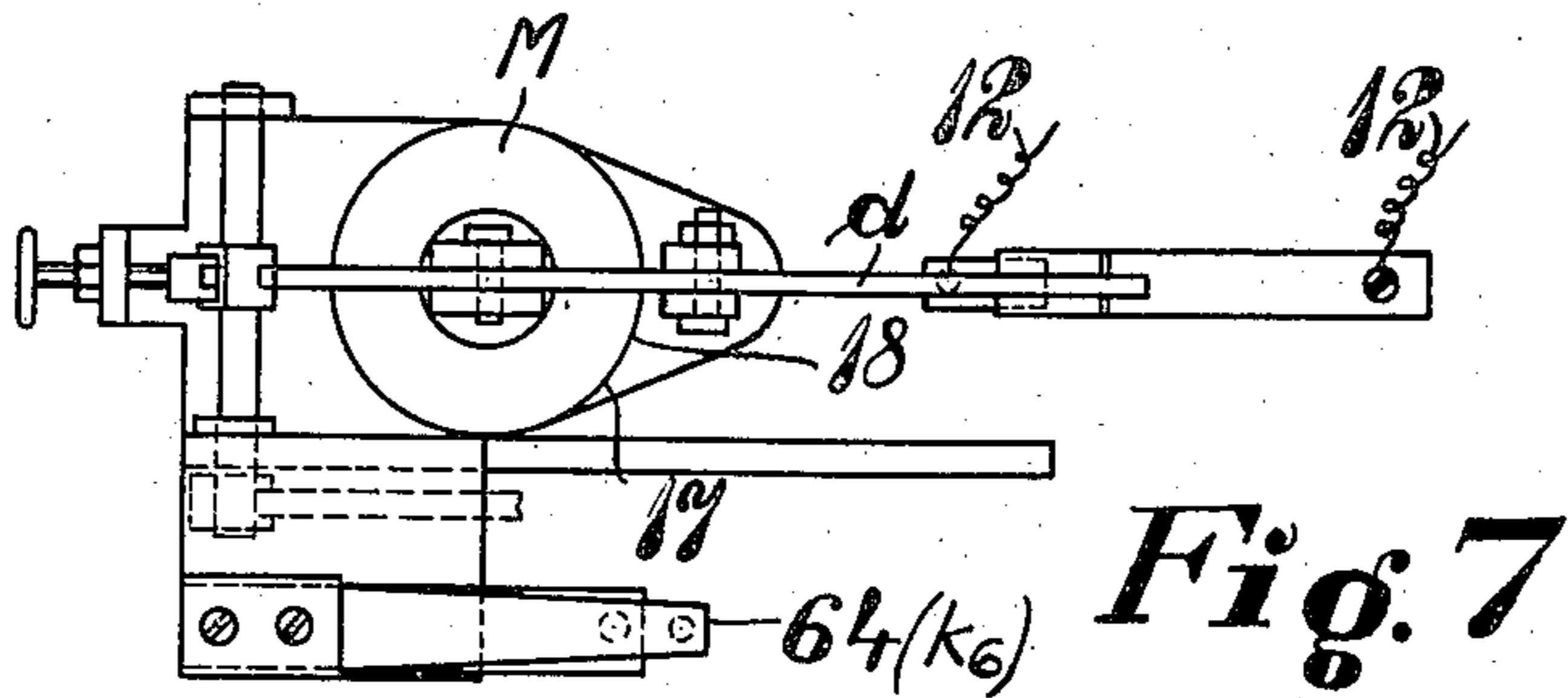
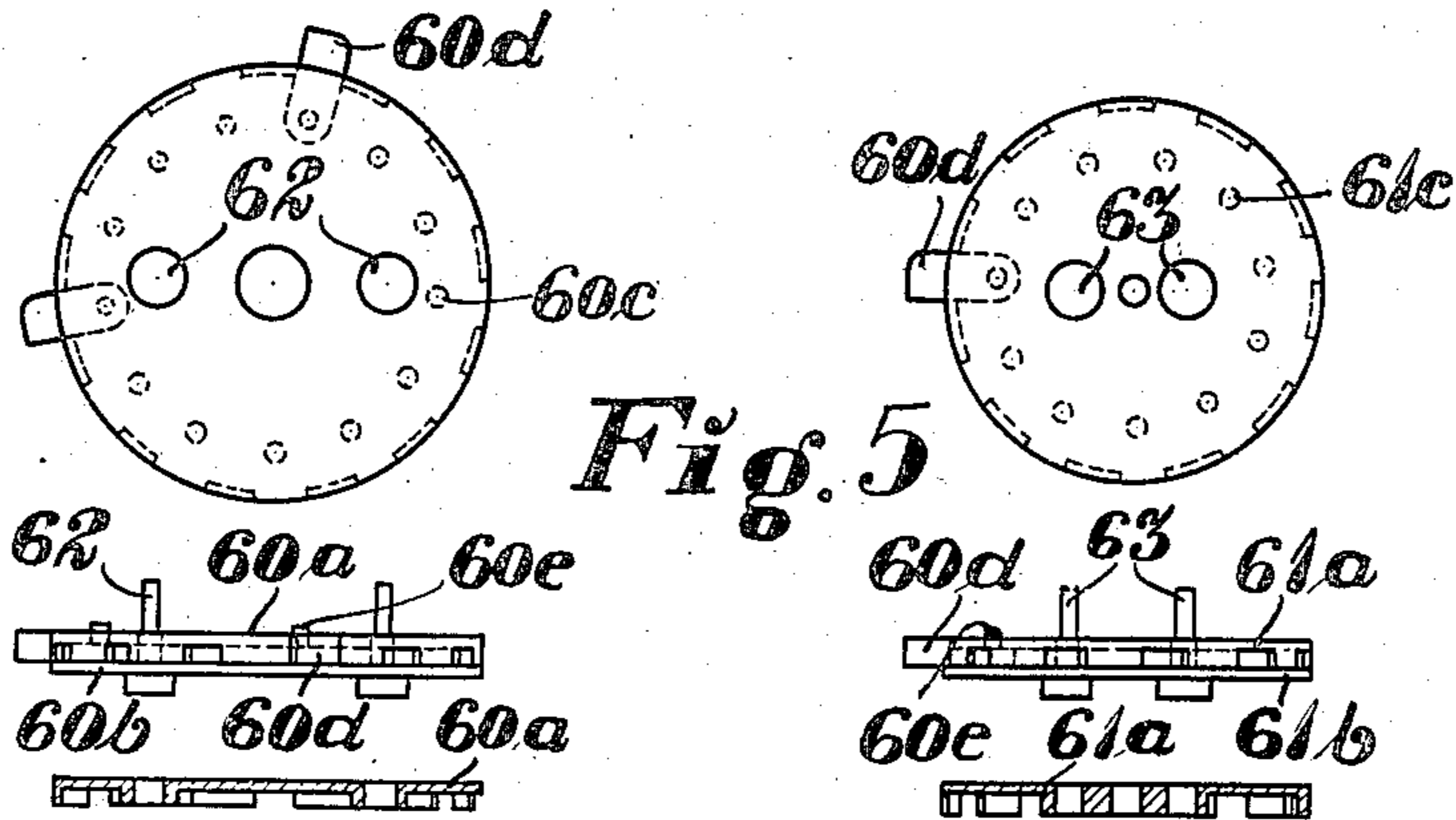
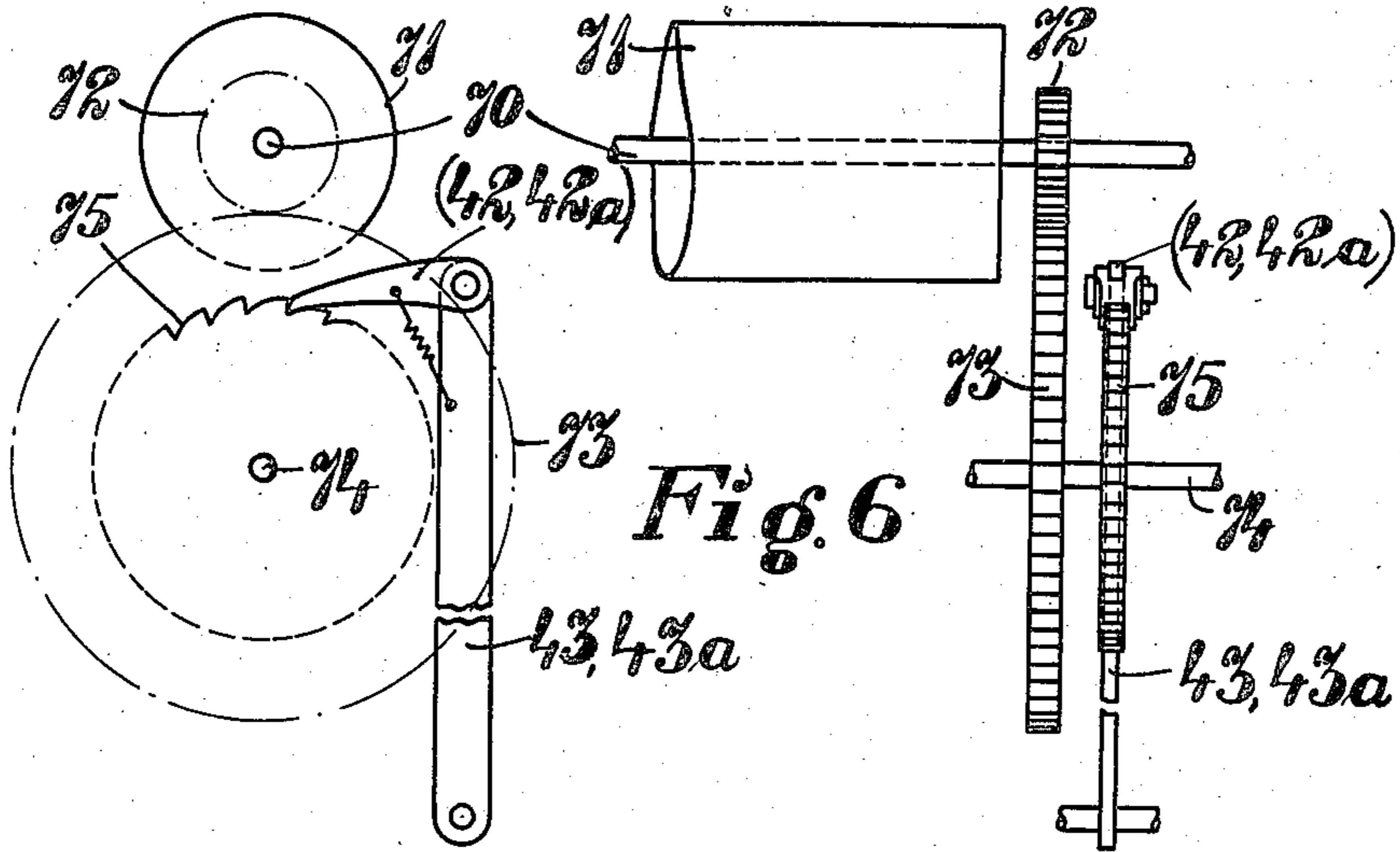

Inventor
Avid Gerhard Damm,
By *[Signature]* atty.

UNITED STATES PATENT OFFICE.

ARVID GERHARD DAMM, OF RONNINGE, SWEDEN.

PRODUCTION OF CIPHERS.

Application filed April 2, 1920. Serial No. 370,708.

To all whom it may concern:

Be it known that I, ARVID GERHARD DAMM, a citizen of the Kingdom of Sweden, residing at Ronninge, Sweden, have invented new and useful Improvements in or Relating to the Production of Ciphers, of which the following is a specification.

This invention relates to a new system and apparatus for enciphering and deciphering messages, also to electromechanical connections between a ciphering apparatus proper and such auxiliary machines of known types, provided with keys corresponding to the different characters or signs used in written, printed or telegraphic correspondence, as may serve the purpose of simultaneously recording by material signs, for instance by printed characters or perforations, the successive manipulations for enciphering or deciphering and the results obtained.

A further object of the invention is to prevent periodical recurrences by causing irregularities in the ciphering process to follow every occurrence of a particular sign in the text enciphered and also to ensure the deciphering of such messages.

The ciphering method or system used in this invention consists in this that the selection of a cipher-sign corresponding to a given text-sign depends upon the momentary positions relatively to each other of two cyclical series or alphabets each comprising all signs that may be used, the order of said signs in one series being reversed as compared to that of the other series, and further upon the relative positions of said series with respect to each other being successively changed as determined by two cyclical key-series, each corresponding to a sequence of movements and stops (periods of rest) of one of the alphabets, so that either the one or the other or both or neither of the alphabets will move a given distance in a certain direction at each individual ciphering operation. The effect of this is a series of positional changes of more than one kind interrupted by occasional stops or not as desired and further upon the occurrence of a certain text-sign having the effect of eliminating the influence of the key-series either by suppressing during the next ciphering operation a relative movement of the alphabets or by causing them to move relatively to

each other independently of the sequence of displacements and stops defined by the key series aforementioned.

A whole ciphering apparatus constructed according to the invention is shown diagrammatically in Fig. 1 of the accompanying drawings. Fig. 2 illustrates the collectors partly in sectional view and partly in side view. Fig. 3 is a side view of the mechanism for stepping a ciphering member. Fig. 4 is a section through the line $a-b$ in Fig. 2. Fig. 5 shows the key-wheel viewed from two different sides. Fig. 6 is a modified form and Fig. 7 a detail view.

Referring to Fig. 1, T is a key of a keyboard actuated according to the text to be ciphered. T_1 is a key of a common typewriter and T_2 is a key of a typewriter or a machine for producing telegraphic signs, for instance in the form of combinations of perforations in paper-strips according to known systems.

The relation between these three machines as to their functions is as follows:

When enciphering, the key T of the ciphering machine proper which corresponds to a casual text-sign is depressed, simultaneously a key T_1 of the typewriter corresponding to the same sign is actuated, the manipulation thus being, for controlling purposes, recorded in print, while a key T_2 of a second typeprinting or perforating machine is simultaneously actuated and records the cipher-sign corresponding to the text-sign in question.

When deciphering, the key T which corresponds to the casual cipher-sign is depressed, key T_1 recording this manipulation by printing the same sign, and T_2 recording the result of the operation, which, in accordance with the method above-mentioned, will necessarily be the corresponding original text-sign, if using the same key-series and starting from the same initial position of the mechanisms when enciphering and deciphering. From the key T depends a rod a provided at the lower end with a metal-pin s . Placed beneath the latter is a rhombic metal-member r electrically connected through a conductor with the positive pole of a source of current.

Arranged at either side of the rhomb r is a metal spring k_1 and k_2 respectively placed at such a distance from the same that

the pin *s*, when positioned between the member *r* and either spring, forces the latter outwards thus effecting electric connection between the spring and the source of current. On the depression of the key T, the pin *s* strikes the upper inclined edge of the rhomb thus being caused to pass between the rhomb *r* and the contact spring k_1 , until the pin *s* passes the lowermost corner of the rhomb. Then the pin *s* is forced by said spring towards the centre line of the rhomb and, on the release of the key T, while striking the lower inclined edge of the rhomb, is forced by the same between the rhomb *r* and the contact spring k_2 . Having passed the upper corner of the rhomb, the pin *s* is moved by the last named spring towards the centre line of the rhomb, the movements described then being repeated at the next depression of a key. The contact spring k_1 is by means of conductors 2, 3 connected with one end of the winding of a solenoid S_1 , the movable armature of which is pivotally connected with a lever *b* which, when depressed, may actuate the first-named type-writer key T_1 . The other end of the winding of solenoid S_1 is by conductors 4, 5^a, 5 connected with the negative pole of the source of current. Consequently, on the depression of the key T the solenoid S_1 will be excited thus causing a depression of type-writer key T_1 . Thereby a type-sign is obtained identical to that marked on the key T. On the depression of the latter another circuit is closed simultaneously passing through the ciphering members C_1 , C_2 of the apparatus described below and in Fig. 1 only indicated diagrammatically as two cylindrical collectors which, by being turned in relation to each other, may obtain different mutual positions thus effecting electric connection between different pairs of contact springs k_3 and k_4 , respectively each bearing against one of said members. The contact spring k_1 mentioned above is by the conductors 2 and 6 connected with a certain contact spring k_3 bearing against the member C_1 and connected in the manner above mentioned with a certain contact spring k_4 bearing against the member C_2 . The spring k_4 is by a conductor 7 connected with one end of the winding of a solenoid S_2 , the other end of the winding being connected by the conductors 8, 5^a, 5 with the negative pole of the source of current. When excited, the solenoid S_2 will actuate, by means of its movable armature pivotally connected with the lever C_2 , a key T_2 of a type-writer or perforating machine giving a cipher sign corresponding to the sign marked on the key T and the nature of which depends upon the position of the ciphering members C_1 , C_2 in relation to each other in a manner to be described in the following.

As mentioned above, the contact spring k_2 will, on the release of the key T, enter into conducting connection with the source of current S, a circuit also being closed through a conductor 9, a solenoid S_3 and the conductors 10, 11, 5^b, 5. The movable armature of the solenoid S_3 is pivotally connected with a stepping device shown diagrammatically in Fig. 1 and turning, for each upward movement of the armature of the solenoid, a circular disk N_1 through a certain part, for instance 1/13, of a revolution, said turning being transmitted by a gear v , v_1 , v_2 to another circular disk N_2 thereby obtaining a corresponding movement corresponding to another part, for instance 1/11, of a revolution. The peripheries of the disks N_1 and N_2 are divided into a corresponding number of parts, for instance 13 and 11. On these parts projections *u* may be placed passing, on turning the disks one step at a time, beneath contacts k_5 and k_6 so as to close the same temporarily. The said projections may, however, be substituted by electrically conducting pieces inserted in the peripheries of the disks, the contacts k_5 and k_6 being constructed as contact springs bearing against the peripheries of the disks. One part of each of said contacts k_5 , k_6 is by conductors 13, 14 connected with one end of a winding of the solenoids S_4 and S_5 respectively, the other part being connected by a conductor 12, 12^a with the positive pole of the source of current. The other ends of the windings of the solenoids S_4 , S_5 are by conductors 15 and 16, 11, 5^b, 5 respectively connected with the negative pole. Consequently, when two projections *u* are so placed as to pass, on the depression of the key T owing to the excitation of the solenoid S_3 , beneath the contacts k_5 , k_6 so as to close the same, both solenoids S_4 and S_5 are excited. The movable armatures of the latter are connected with adjusting mechanisms for the ciphering members C_1 and C_2 shown diagrammatically in Fig. 1 and more particularly described below, both of the said members under the said presumption thus being turned to a certain extent, said turning, if effected in opposite directions in both members, always causing a mutual adjustment of the members resulting in an altered relation between the respective text and cipher signs. If one projection *u* only is in a position adapted to close either contact k_5 or k_6 , one ciphering member only will be adjusted with the result of an alteration of the ciphering relation. If on the contrary no projection in either disk N_1 or N_2 has assumed such a position, the relative adjustment of the ciphering members will remain unchanged.

In order to have the movement or period of rest of the ciphering members, as mentioned in the preamble, to depend to a cer-

tain extent upon the occurrence and position in the text of any certain letter, or, in other words, upon the key T being depressed at any certain occasion during the ciph-
 5 ciph-er-ing, a switch device is inserted in the conductor 12 consisting of a stationary contact piece d_1 , a contact arm d swingable about its middle point and an electromagnet M breaking, when excited, the contact
 10 d, d_1 . The arm d has a projection e , and bearing against the same is a spring f in such manner as to retain the contact d in breaking position, even if the magnet is inoperative, until the movable armature of
 15 the solenoid S_2 or a member connected therewith as a ratchet lever and pawl strikes, at the end of its path of movement, the arm d thus returning the same to contact with d_1 . If for instance the letter "a" is selected as
 20 influence-letter and if one end of the winding of electromagnet M is connected by a conductor 17 with the conductor 2 of the key T marked with the letter "a" and the other end of the winding by a conductor 18
 25 with the conductor 5, a standstill of the ciph-er-ing members will obviously take place, each time the text letter "a" has been ciph-er-ed. Consequently, an irregularity of the ciph-er-ing depending upon the occur-
 30 rence of the letter "a" in the plain text will take place. When the same magnet M on deciph-er-ing, is connected by switch 17^a to conductor 7 of the solenoid S_2 actuating the key T₂ marked with "a" of the type-writer
 35 or perforating machine, the same standstill and irregularity will obviously take place, each time a cipher sign corresponding to the text letter "a" has been touched on any one of the starting keys T.

40 The two solenoids M and S_2 are connected, when switch 17^a is moved to the position shown in dotted lines, in parallel to the negative side of the battery S, and are connected through a key T and line 7 to the
 45 positive side of the battery S when said key is depressed, as follows: negative side of S, line 5, solenoid M, line 17, switch 17^a to line 7; negative side of S, lines 5, 5^a and 8, solenoid S_2 line 7; both circuits then continuing through line 7, contact k_4 cylinder
 50 c_2 , cylinder c_1 , contact k_3 , lines 6 and 2, spring k_1 , pin s , member r , line 1 to positive side of battery S, thus causing the solenoids to operate.

55 Thus, the deciph-er-ing is effected in such manner that the key board T is actuated according to the cipher obtained, the original text thus being obtained in the type-writer T₂.

60 If, in the ciph-er-ing of a message more than one influence letter has been used, it will be necessary, when deciph-er-ing, to connect each of the solenoids S_2 corresponding to the influence letters with an electromagnet M, since otherwise all the solenoids S_2

corresponding to the influence letters would be excited, each time a sign corresponding to any one of said letters is deciph-er-ed.

70 If it be desired to obtain, instead of a standstill of the ciph-er-ing members, each time the influence letter is ciph-er-ed, a movement of said members independent of the movement caused by the contacts k_5, k_6 , it is only necessary to insert the switch d, d_1
 75 in the circuits of the solenoids s_4, s_5 , that is to say between the conductors 13 and 12 and 14 and 12^a respectively and so to arrange the switch that it is normally open, but pre-
 80 vailingly closed by the electromagnet M, when ciph-er-ing the influence letter.

85 The general course of the functions of the different devices having been diagrammatically described above, said devices will be more particularly treated below in their actual embodiments, reference being had to
 Figs. 2, 3, 4, 5, 6 and 7.

Each of the two ciph-er-ing members C_1 and C_2 shown in Fig. 2 is fastened to a shaft 21 and 22 respectively, said shafts being placed coaxially and adapted to be
 90 turned in bearings 26, 27 and 28 secured to the walls 68 and 68^a of the apparatus and to an intermediate support 36. Each member consists of a metal tube 23, 23^a enclosing the shaft concentrically at a certain distance and held between two pieces 29, 30
 95 and 29^a, 30^a secured to the shaft. The pieces 29, 29^a have the form of ratchet wheels, and the pieces 30, 30^a consist of circular disks each provided with a cylindrical
 100 flange. Slid onto the tubes are rings 25, 25^a insulated from one another and the tubes. Each ciph-er-ing member has a number of metal rings equal to that of the starting keys T (Fig. 1). Placed on the shafts 21,
 105 22 are also circular disks made of insulating material and having circularly arranged contact pins 35, 35^a placed in each disk at equal intervals and in a number equal with
 110 that of the metal rings 25 and 25^a respectively of each cipher member. Each contact pin 35, 35^a is by an insulated conductor 67^a electrically connected with any one of the said metal rings 25, 25^a in arbitrary order.
 115 The arbitrary order of said connections is reverse in the two ciph-er-ing members, and consequently, if said members are considered to be placed side by side having the ratchet
 120 wheels 29, 29^a positioned in the same direction, the ciph-er-ing members would be identical. Inserted from both sides in metal sockets 37 placed in the stationary intermediate support 36 are contact pins 38, 38^a
 125 forced outwards by coiled springs 39 and arranged circularly at equal intervals with the aforementioned pins 35, 35^a, the metal rings of the ciph-er-ing members C_1, C_2 thus being adapted to be electrically connected in pairs by suitable adjustment of said members. Bearing against each of the metal

rings is a contact spring 66 secured to a stationary piece 69 and 69^a respectively made of insulating material. Said springs correspond to the contact springs k_3 and k_4 respectively shown in Fig. 1.

The ratchet wheels 29, 29^a placed at the outer ends of the ciphering members C_1 , C_2 are provided on their sides with ratchet teeth 41, 41^a in a number equal with that of the contact pins 35, 35^a mentioned above (Fig. 3). Each ratchet wheel may be turned by means of a pawl 42 pivoted on an arm 43 pivotally mounted on a pin 44. The arms 43 are forced by springs 46 against stops 45, but are adapted, on the exciting of electromagnets 47, to be attracted by the latter against their pole ends, the ratchet wheels 29 thereby being fed forward one step and by means of projections 48 formed on the arms and stopping the ratchet teeth 41, prevented from moving further on account of the inertia.

The excitement of either or both of the said magnets 47 is effected by the following devices. Pivotally mounted on a pin 49 fastened to the frame of the apparatus is a ratchet wheel 51 constructed in the same manner as the aforesaid wheels 29, 29^a and adapted to be turned stepwise as the latter by means of a pawl 55 secured to a movable arm 56 pivotally mounted on a pin 59, the said arm being adapted to be raised by an electromagnet 76 and provided with a tooth 57 preventing further movement of the wheel 51 on account of the inertia. Secured to the ratchet wheel is a toothed wheel 52 having as many teeth as the teeth of the ratchet wheel and gearing with an intermediate wheel 53 mounted on a pin 48 and gearing with a toothed wheel 54 mounted on a pin 50. Placed at the side of the toothed wheels 52, 54 on the same pin is a cylindrical member 60 and 61 respectively caused by a screw 62 and 63 respectively to partake in the rotation of the toothed wheel (see Fig 4). As will appear from Fig. 5, both members 60 and 61 consist of circular disks 60^a, 60^b and 61^a, 61^b respectively, being provided at the circumference with a flange having a certain number of recesses and an equal number of perforations 60^c and 61^c respectively placed concentrically within the flange. In said recesses loose members

60^d may be inserted which by means of pins 60^e entering the perforations 60^c, 61^c are retained so as not being able to be displaced, after the disks 60^b, 61^b, by screwing home the aforesaid screws 62, 63, have been connected with the members 60^a and 61^a respectively.

The members 60^d projecting as lugs outside the periphery of the disks 60^a, 61^a are destined, on stepwise turning of the rotating members, to close either or both of two contact devices 64, 65. As a lug 60^d passes beneath the contact device 64 corresponding to the contact k_6 in Fig. 1, a circuit is closed, as mentioned above, exciting the solenoid 47 at one side of the apparatus. A lug 60^d passing beneath the contact device 65 corresponding to the contact k_5 in Fig. 1, the solenoid 47 at the other side of the apparatus is energized. In the embodiment shown in Figs. 2, 3, 4 and 5 the pitch and ratio of gear of the ratchet wheels 29, 29^a, 51, the toothed wheels 52, 53, 54 and the disks 60^a, 61^a, the latter being termed "key wheels" in the following, are chosen so as to have no factor in common, the wheels 29, 29^a having for instance 29 teeth, the wheel 51, 13 teeth, the key wheel 60^a, 13 recesses and the key wheel 61^a, 11 recesses destined for the lugs 60^d placed arbitrarily. According to the embodiment shown the total period of movement (single series of mutations before repetition occurs) of the ciphering members corresponds consequently to $13 \cdot 11 \cdot 29 = 4,147$ depressions of the keys.

Assuming that the keys T (Fig. 1) carry the characters of an alphabet and three additional characters the same alphabet being also represented by the keys T₂, assume contact-spring k_1 of key T carrying letter "a" to be connected through conductor 6 to the first contact spring 66 to the right (Fig. 2) of the right hand cylinder, the solenoid S₂ of key T₂ carrying letter "a" to be connected through 7 to the first contact spring to the left of the left hand cylinder, supposing the sequential order of characters of the alphabet to correspond to the sequential order of metal rings 25 (Fig. 2) from right to left and rings 25^a from left to right, further supposing the sequential order of connections between said metal rings 25, 25^a and contacts 35, 35^a respectively to be:

Ring No.	1, 2, 3, 4, 5, 6, 7, 8, 9, 10, 11, 12, 13, 14, 15, 16, 17, 18, 19
Contact No.	26, 7, 4, 11, 9, 16, 29, 19, 21, 3, 8, 1, 17, 10, 23, 2, 14, 13, 6

Ring No.	20, 21, 22, 23, 24, 25, 26, 27, 28, 29,
Contact No.	25, 15, 20, 28, 5, 22, 18, 12, 27, 24.

counting the contacts in the direction of movement of each cylinder, further supposing the key-series and its initial position for one cylinder to be 11011100111, and same for the other one to be 1010100111111, the sign

1 standing for movement and sign 0 for period of rest, and the initial relative position of the ciphering cylinders to be such as to connect the first ring to the left on the left hand cylinder to the first ring to the

right on the right hand cylinder, then the depression of key T carrying letter "a" would of course cause the key T₂ carrying the same letter "a" to be depressed. On releasing said key T, each ciphering-cylinder would, according to the key-series, move one step, consequently if key T for letter "a" were again depressed, the impulse would pass through ring number 1, and contact number 26 on the right hand cylinder on to contact number 28 and ring number 23 on the left hand one, thus causing key T₂ for letter "w" to be actuated, the reversed relation for deciphering between key T for letter "w" and key T₂ for letter "a" being at the same time established, the impulse in this case passing through ring number 23, and contact number 28 on the right hand cylinder on to contact number 26 and ring number 1 on the left hand one.

When releasing key T for letter "a" a second time, only one of the cylinders will, according to the key-series assumed, move one step, a third depression of the same key T then causing a depression of key T₂ for letter "g."

The sequence of relative displacements of the cylinders under the above suppositions would be the following numbers of steps: 2, 1, 1, 1, 2, 1, 0, 1, 2, 2, 2, 2, 2, 1, 1, 2, 1, 1, 0, 1, 2, 2, 2, 2, 1, 2, 2, 1, 1, 0, 2, 1, 1, 2, 2, 1, 2, 2, 2, 1, 0, 2, 1, 2, 1, 1, 1, 2, 2, 2, 1, 1, . . . with a period of $11 \times 13 = 143$ terms, the numerals 1, 2 and 0 designating movements and periods of rest following successive depressions of key T the sequence of cipher-sign corresponding to successive depressions of key T for letter "a" would be:

a, w, g, l, p, c, x, x, s, k, n, e, q, f, m, z, v, i, y, y, o, t, ü, g, p, j, x, b, k, e, e, d, e, r, u, m, z, v, y, n, t, t, ü, w, l, p, j, c, s, k, n, d, e, . . . with a period of $29 \times 143 = 4147$ letters.

In the above example it has been supposed that letter "a" is not chosen as the letter which influences the ciphering by irregularities. Under the same conditions and if "e" is chosen as influencing letter, the word "letters" would be ciphered: y g l z q y, the cipher of the same word without any influencing letter being: y f l p h m t.

In the apparatus described both ciphering members C₁, C₂ are turned at each movement through the same angle. The apparatus may, however, be so modified, that said members, by changing the gear members, obtain different angles of rotation in relation to each other. The movement of the key wheel 61^a may, by suitable arrangement of the gear members, obtain any desired magnitude in relation to the movement of the key wheel 60^a, and the pitch of the key wheels with reference to the recesses for the lugs 60^d may be varied. Fig. 6 illustrates a device for effecting any desired

movement of one of the ciphering members. In this case the ratchet wheel 75 is not mounted on the shaft 70 supporting the ciphering member 71, but on an arbor 74 carrying also the toothed wheel 73. The latter gears with a toothed wheel 72 secured to the shaft 70 of the ciphering member, the movement of the member 71 for each movement of the ratchet wheel 75 by means of any pawl 42 or 42^a on the arms 43 and 43^a thus depending on the ratio between the diameters of the toothed wheels 72, 73. Said toothed wheels are changeable. The number of teeth of the ratchet wheel 75 is, on the contrary, always equal to the number of the keys of the apparatus. By choosing suitably the gear wheels it may for instance be effected that the one ciphering member, if the number of the keys be 29, turns through $2/29$ of a revolution and the other one for instance $4/29$.

By changing the number of teeth of the wheels 51, 52, 54 (Figs. 2 and 4) and a corresponding change of the recesses in the wheels 60^a and 61^a for inserting the lugs 60^d, arbitrary relations between the turning of the two key-wheels for each depression of a key may, of course, be obtained, and likewise different arrangements of the lugs 60^d may effect different series of operation. The angles of rotation of the key-wheels should always correspond to so great a part of a revolution, as is determined by the number of recesses of the wheels 60^a and 61^a. Supposing the following relations: 17 teeth in the wheel 51, 34 teeth in the wheel 52, 44 teeth in the wheel 54 and 17 and 23 recesses for lugs to be inserted in the wheels 60 and 61 respectively, a period of $17 \times 23 = 391$ key-depressions would be necessary for returning the key-mechanisms to starting position quite independent of the number of lugs inserted.

Having now described my invention I declare that what I claim is:—

1. In a machine for producing cipher, means corresponding to two series of contacts arranged opposite to one another, means to cause the stepwise movement of said contacts relatively to one another, mechanism to cause the interruption of the stepwise movement of either or both of said series of contacts.

2. In a machine for producing cipher, means corresponding to two series of contacts arranged opposite one another, means to cause a relative, regular stepwise movement of said contact series, mechanism to change the regularity of the stepping of said contacts and means to control the operation of said mechanism.

3. A machine for producing cipher comprising means corresponding to two series of cipher characters, means for displacing the means corresponding to the two series of

cipher characters one with respect to the other, means for controlling the periodic movement of either or both series in accordance with a selected periodicity and means to produce irregularity in such periodic movement.

4. A machine for producing cipher, which comprises key mechanism two displaceable cipher means, means to control the displacement of either or both said cipher means in accordance with a selected periodicity, and means for producing irregularity in accordance with a key for a definite character.

5. In apparatus for producing cipher dispatches the combination with a manually operated key board, and recording mechanism of two co-operating ring commutator drums, brushes therefor, each brush of one drum electrically connected to a key of said key board, and each brush of the other drum electrically connected to said recording mechanism to record its pertaining cipher character and electrical means in circuit with key mechanism of said manual key board, to step one or both drums.

6. In apparatus for producing cipher dispatches the combination with a manually operated key board, and a cipher mechanism of two co-operating ring commutator drums and brushes therefor, brushes of one drum electrically connected to the key levers of said manual key board and brushes of the other drum electrically connected to the cipher mechanism electrically operated selective drum stepping mechanism in circuit with manual key mechanism, whereby the cipher mechanism will be operated upon the depression of a manual key and a different cipher for each repeated operation of a manual key dependent upon the relative movement of said drums, be given.

7. In apparatus for producing cipher dispatches the combination with a manually operated key mechanism and cipher mechanism of two co-operating ring commutator drums, each ring terminating in a contact in a circular row on its end face, and the two rows of contacts on the drums in sliding contacting relation, brushes for one drum each electrically connected to a manual key and brushes for the other drum each connected to the cipher mechanism electrically operated stepping mechanism for each drum arranged to step each drum at selected periods but to different extents and included in manual key circuits.

8. In apparatus for producing cipher dispatches the combination with a manually operated key mechanism and a cipher mechanism of two co-operating ring commutator drums, brushes for each drum, the brushes of one drum electrically connected to the manual key board, and the brushes of the

other drum electrically connected for operating the cipher mechanism electrically operated drum stepping mechanism in circuit with manual keys, and means to break the circuit of the stepping mechanism upon the depression of a definite manual key.

9. In apparatus for producing cipher dispatches, and for deciphering the same, the combination with a manually operated key mechanism and a cipher mechanism of two co-operating ring commutator drums whose individual rings are electrically connected to sliding contacts arranged concentrically with their axes at their opposed ends brushes for each ring, the brushes of one drum electrically connected to the manual key mechanism and the brushes of the other drum electrically connected to the cipher mechanism, electrical means to selectively control the stepping of the drums, and means dependent upon the actuation of a particular manual key or keys to temporarily discontinue the operation of the stepping mechanism.

10. In apparatus for producing cipher dispatches and for deciphering the same, the combination with manually operated key mechanisms and cipher mechanisms, of two aligned ring commutator drums having co-operating end contacts connected to their respective rings, brushes for said rings, the brushes for one drum electrically connected to said manual key mechanism and the brushes for the other drum electrically connected to said cipher mechanisms, electrically operated stepping means for said drums, means to selectively control the sequence of operation of said stepping mechanism, means controlled from a manual key or keys to temporarily electrically disconnect the stepping mechanism and recording mechanisms in parallel with the manual key mechanisms to record a tally of the text to be ciphered.

11. In a machine for producing cipher, a cipher recording mechanism, a ciphering mechanism comprising two series of co-acting contacts corresponding to two series of characters movable one with respect to the other and controlling the operation of the recording mechanism, electrically operated means for stepping either or both said series of contacts, means to control the operation of said stepping means, a sending key board having on each key means to first send operating current through said coacting contacts to the recording mechanism and thereafter to the controlling and stepping mechanism, and means connected to a key to break the operating circuit for a stepping device.

In testimony whereof I have signed my name.

ARVID GERHARD DAMM.