

A. A. KENT.
 INDUCTION COIL STRUCTURE.
 APPLICATION FILED JULY 9, 1921.

1,391,256.

Patented Sept. 20, 1921.
 2 SHEETS—SHEET 1.

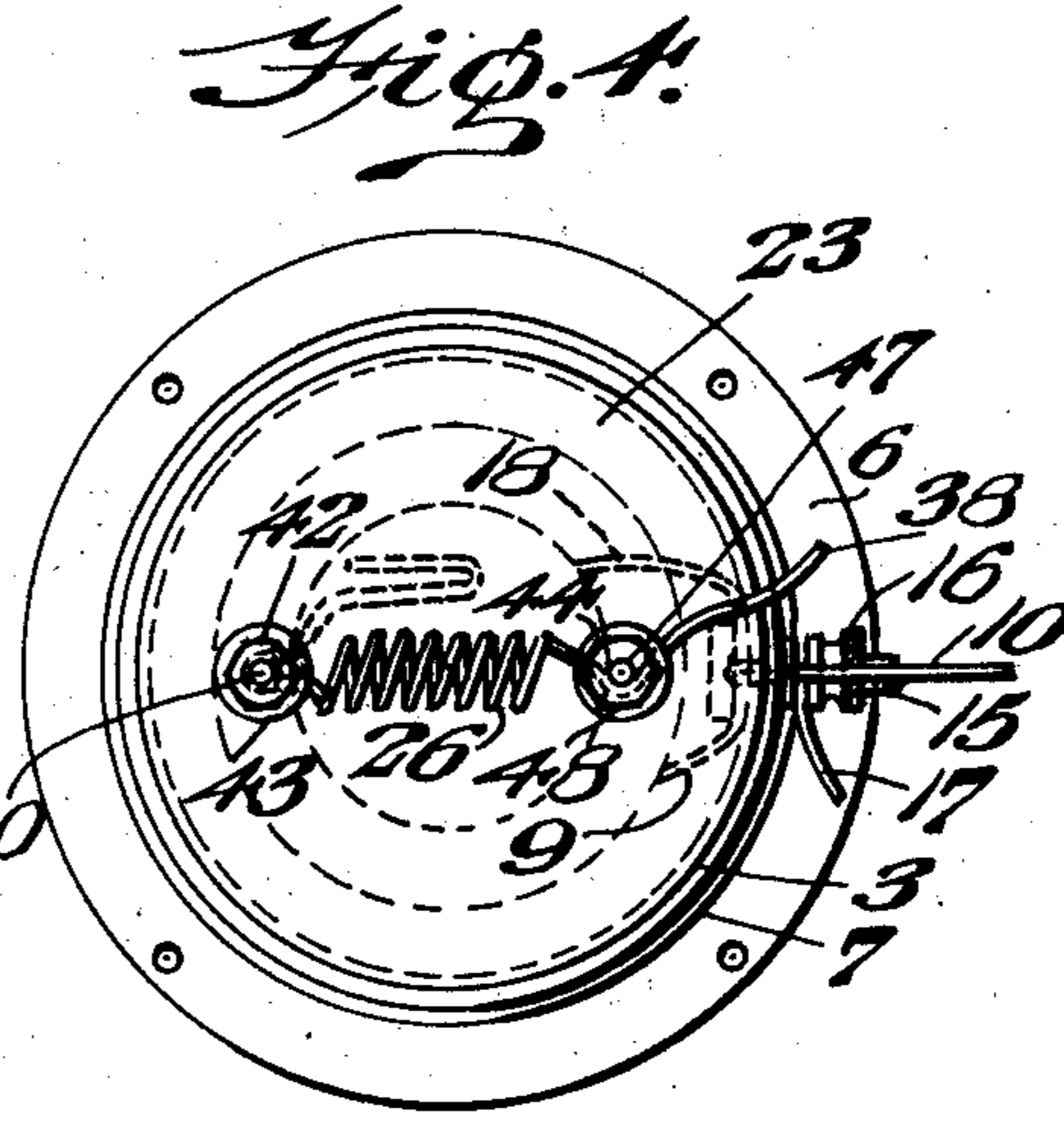
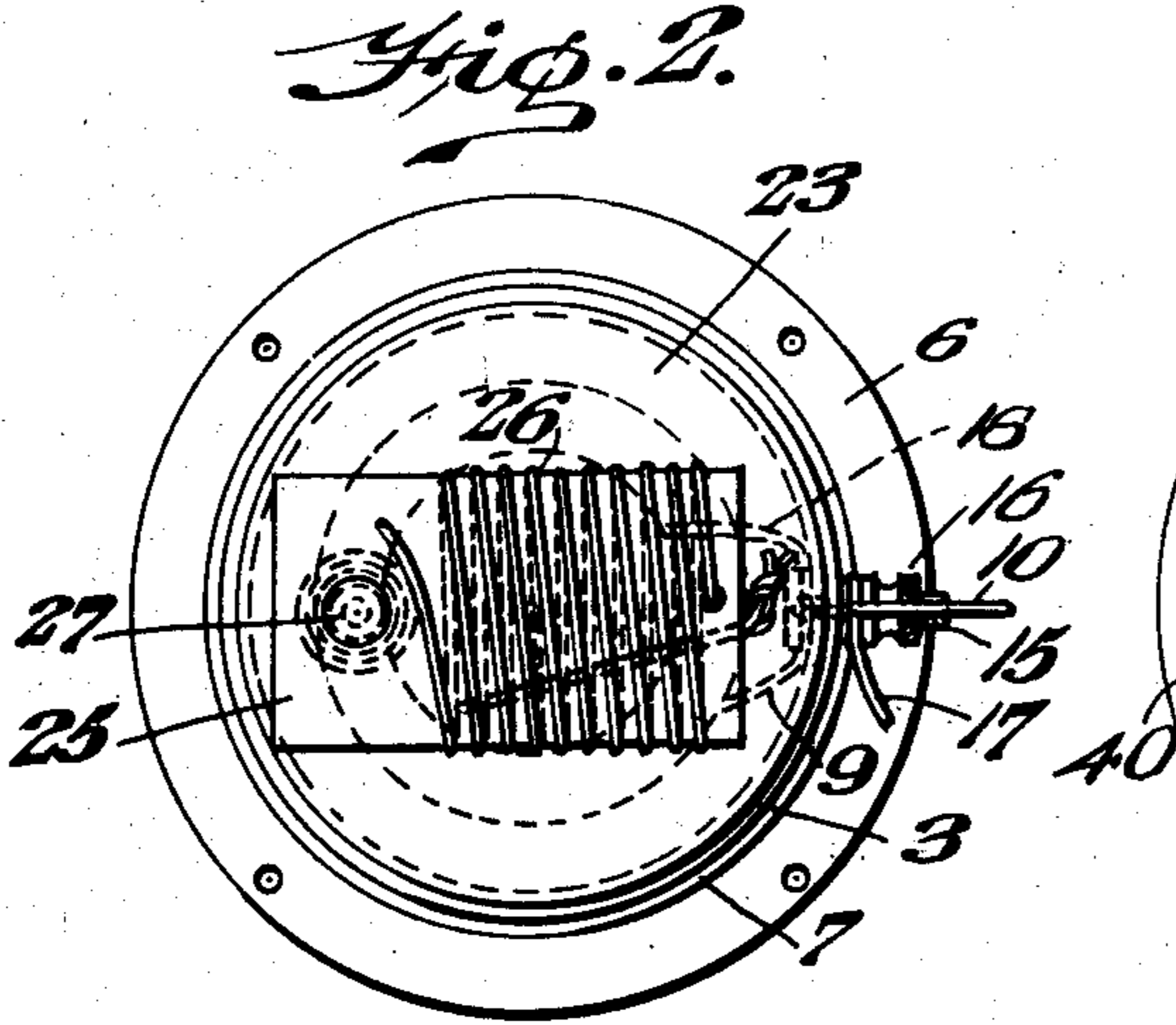
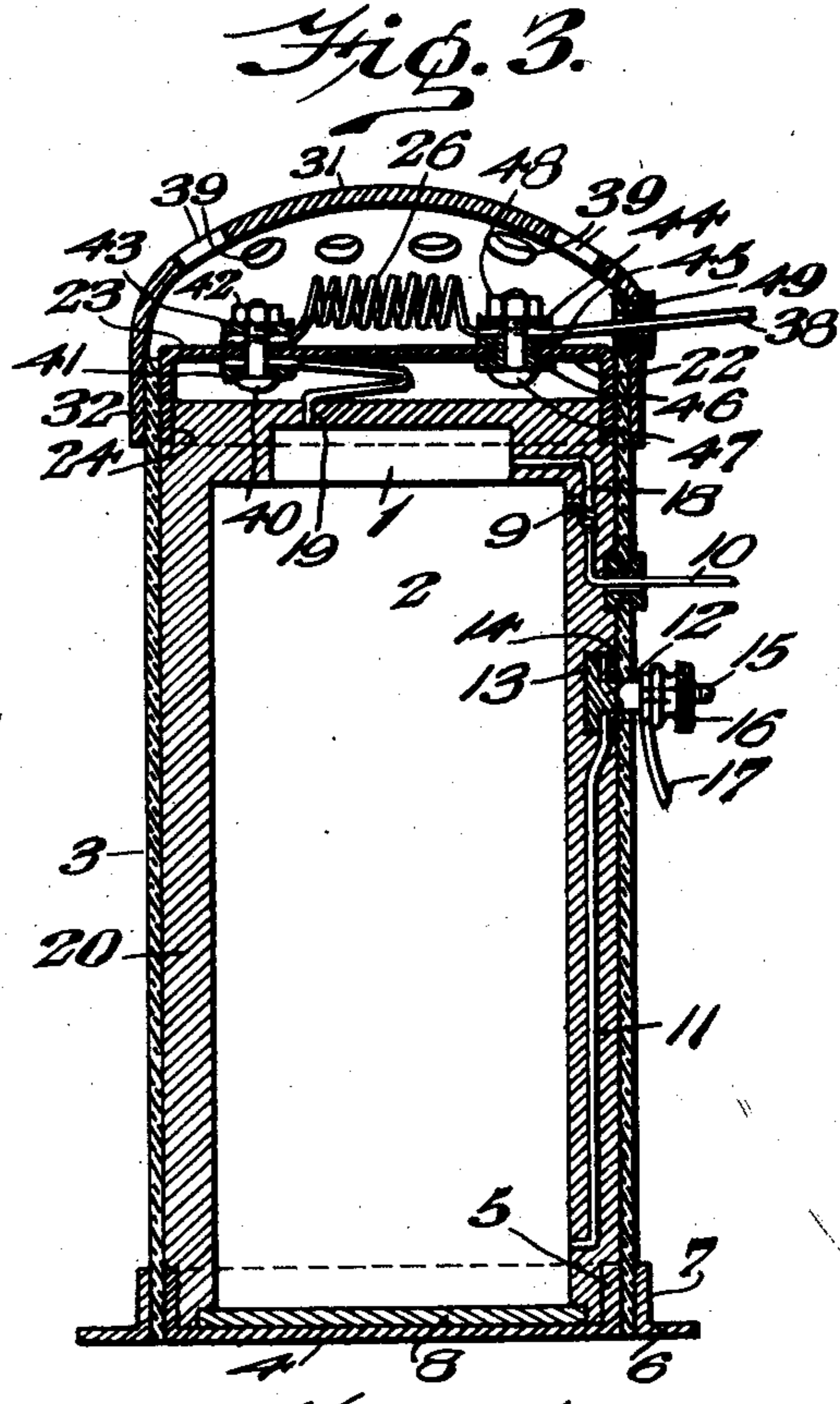
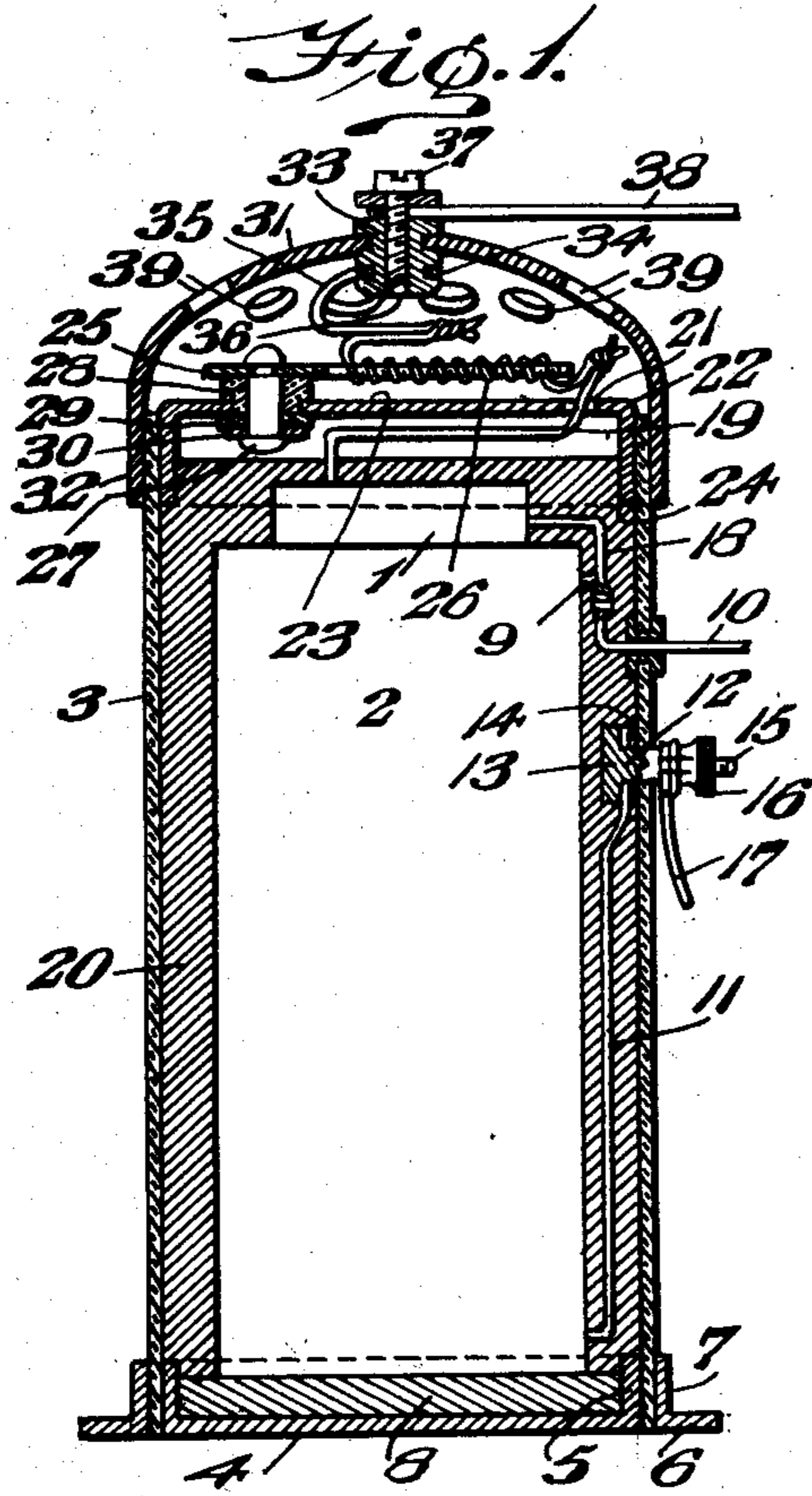

Witness:
Stellie Field
Dorothy A. Thomas

INVENTOR
Arthur Atwater Kent
 BY *Cornelius D. Ches*
 his ATTORNEY

A. A. KENT.
 INDUCTION COIL STRUCTURE.
 APPLICATION FILED JULY 9, 1921.

1,391,256.

Patented Sept. 20, 1921.

2 SHEETS—SHEET 2.

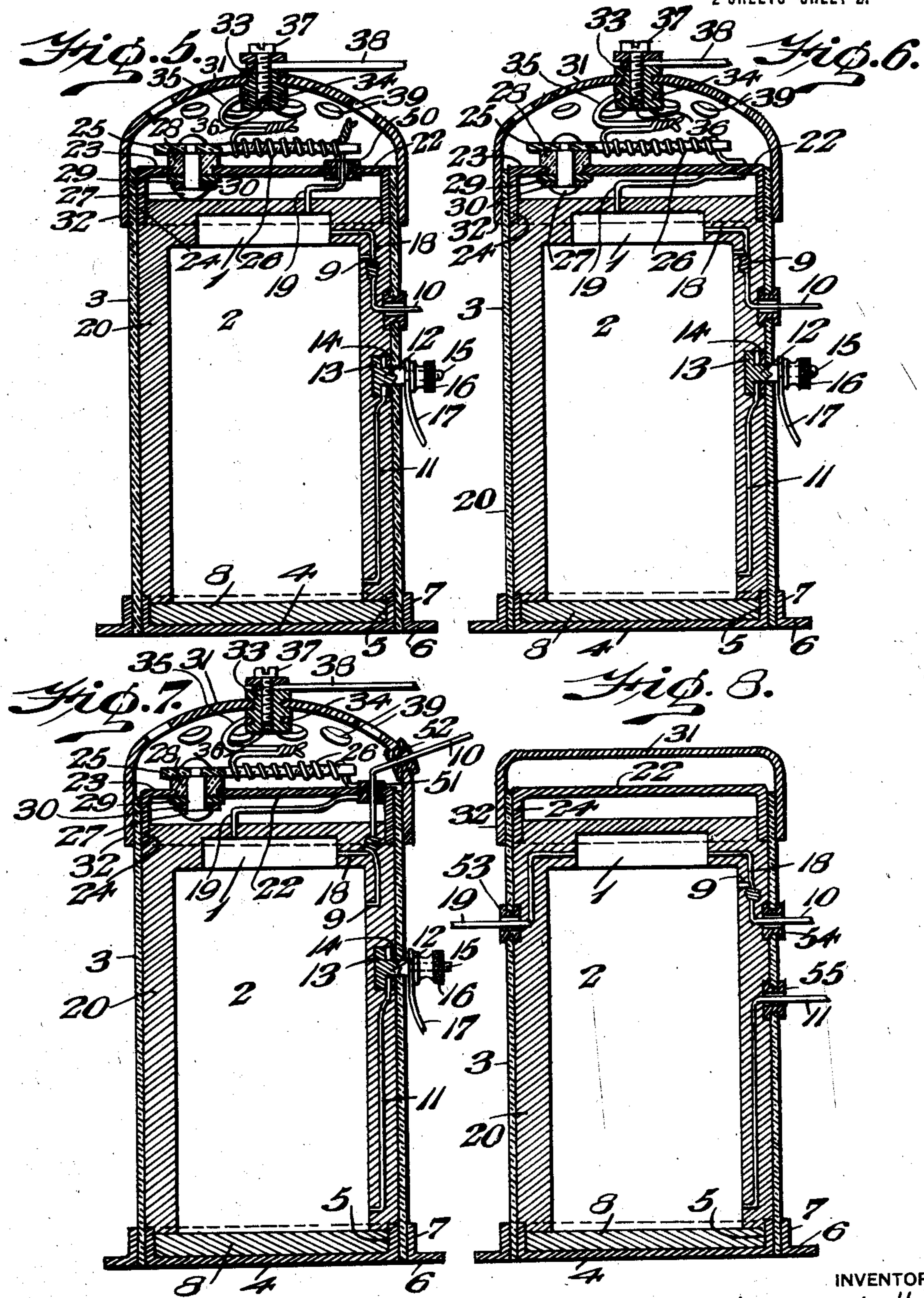

Witnesses:
 Nellie Field
 Dorothy U. Thomas.

INVENTOR
 Arthur Atwater Kent
 BY
 Cornelius S. Chert
 his ATTORNEY

UNITED STATES PATENT OFFICE.

ARTHUR ATWATER KENT, OF ARDMORE, PENNSYLVANIA, ASSIGNOR TO ATWATER KENT MANUFACTURING COMPANY, OF PHILADELPHIA, PENNSYLVANIA, A CORPORATION OF PENNSYLVANIA.

INDUCTION-COIL STRUCTURE.

1,391,256.

Specification of Letters Patent. Patented Sept. 20, 1921.

Continuation of application Serial No. 131,749, filed November 16, 1916. This application filed July 9, 1921. Serial No. 483,423.

To all whom it may concern:

Be it known that I, ARTHUR ATWATER KENT, a citizen of the United States, residing in Ardmore, county of Montgomery and State of Pennsylvania, have invented certain new and useful Improvements in Induction-Coil Structures, of which the following is a specification.

My invention relates to induction coils and particularly to those coils that are adapted for use in the sparking systems of internal combustion engines.

The objects of this invention, are to provide an induction coil that is entirely inclosed and protected, and is also easily and cheaply constructed and assembled; to provide a casing therefor, which is strong, stiff, durable and light in weight; to provide the induction coil proper with a suitable resistance to prevent heating of the coil when the primary circuit is closed for relatively long periods, to provide a housing for the resistance; and to make a coil which is attractive, and simple in appearance.

Other objects of my invention will appear in the specification and claims below.

Referring to the drawing forming a part of this specification and in which the same reference characters are used to designate the same parts throughout the views, Figure 1 is a vertical section of an induction coil embodying my invention, the primary and secondary windings not being shown in section; and Fig. 2 is a plan view of the device shown in Fig. 1, with the upper outer cap or cover removed.

Fig. 3 is a view, similar to Fig. 1, showing a modified construction, and Fig. 4 is a plan view of the same with the outer cap removed.

Figs. 5, 6, 7 and 8 show further modified forms of the invention.

The induction coil proper consists of two windings, as usual, a primary winding or coil 1 and a secondary winding or coil 2, surrounding the primary coil. The casing therefor preferably consists of insulating material in the form of a tube 3 of cardboard, fiber, or other thick paper. Into one end of said tube 3 a disk 4, preferably of sheet metal, having an integral peripheral

cylindrical flange 5, slightly larger than the diameter of the interior of the tube 3, is forced under considerable pressure with a flange extending tightly into the tube 3, and the disk 4 substantially flush with the end of the tube 3.

Over that end of the tube 3 into which the flanged disk 4 has been so inserted, a sheet metal ring 6 is next forced, under pressure, said ring 6 being provided with an integral cylindrical flange 7 of the same diameter as, or slightly smaller than the outside diameter of the tube 3, and which tightly fits over the exterior surface of the end of the tube 3. In this manner the cylindrical flanges 5 and 7 of the disk 4 and ring 6, respectively, tightly clamp and hold the tube 3 between them and the said flanges also greatly stiffen the said disk 4, ring 6 and tube 3.

A disk 8 of cardboard, fiber or other material, which is preferably non-magnetic and a non-conductor of electricity, is then placed within the tube 3 resting on the disk 4 and the induction coil, comprising the primary coil 1 and secondary coil 2, is placed centrally in the tube 3 resting on the disk 8 and with a terminal 9 of the secondary coil 2 connected to the primary lead 10, through which it may be grounded or otherwise suitably connected in circuit.

The other terminal 11 of the secondary coil is attached to a binding post 12 passing through and tightly fitting into a hole through the tube 3. The binding post may be provided with a flanged head 13 and between said head 13 and a metal washer 14, the said terminal 11 may be held in good electrical contact. The outer end of said binding stud 12 may be provided with screw threads 15 over which the knurled nut 16 may be threaded for the purpose of attaching thereto a lead wire 17 of the secondary circuit.

One terminal 18 of the primary coil is preferably connected to the lead 10 and may be thus grounded. The other lead 19 is preferably left extending upwardly from the primary coil 1.

The tube 3 with the induction coil therein is then preferably filled with melted wax,

paraffin, or some similar insulating material 20 to nearly the top of the tube 3 so that the induction coil is completely inclosed and covered thereby and the wax is allowed to
5 cool and solidify, the terminal 19 of the primary coil extending above the top surface of the wax or paraffin.

The terminal 19 of the primary coil is now passed through an opening 21 in an
10 inner diaphragm, cover or cap 22, preferably of sheet metal, and comprising a disk-like top 23, and a cylindrical flange 24, the outer diameter of which flange is of the same or slightly larger diameter than the inner
15 diameter of the end of the top of the tube 3. The flange disk 22 is then forced under pressure tightly into the tube 3 until the top end of the tube and the top 23 of the inner cover 22 are substantially flush.

20 On the top of the inner cover 23 is secured a preferably rectangular sheet or plate of mica 25 around which is wrapped in spiral separated coils a length of preferably nickel wire to form a resistance coil 26. This mica
25 plate 25 may be secured to the top 23 of the inner cover 22 by a rivet 27 passing through said mica plate 25, through a bushing 28, which may be of insulating material, and through an insulating washer 29 and a
30 metal washer 30 on the other or inner side of the inner cover 22. One end of said resistance coil 26 is secured in any suitable manner to the end of the lead 19 passing through the opening 21 of the inner cap 22.

35 Over the upper end of the tube 3, and inclosing the resistance coil mounted on the top of the inner cover or cap 22 is an outer metal cover or cap 31, provided with a cylindrical flange 32, the inner diameter of
40 which is slightly less than the outer diameter of the tube 3. This outer cap or cover 31 is preferably provided at its center with a brass stud 33, the top end of which is passed through a suitable opening in the
45 top of the outer cap or cover 31 and is headed over by pressure and thus firmly substantially riveted thereto. This brass stud or bushing 33 is preferably provided inside of the cap or cover 31 with a groove
50 34 into which one end of the piece of copper wire 35 is wrapped. Preferably this wire 35 is wrapped around the said stud or bushing 33 when the bushing is inserted through the cap 31 and then the said stud 33 is com-
55 pressed between dies under high pressure to head over the top of the stud or bushing 33 and secure it thus to the cover, and to close the groove 34 upon the wire 35 to firmly unite the said wire 35 to the stud or bush-
60 ing 33.

The stud or bushing 33 is preferably provided with a tapped hole 36 for the reception of a binding screw 37 to which a lead 38, adapted to be attached to the interrupt-
65 ing mechanism may be attached.

The other end of the resistance coil 26 is connected to the copper wire 35 and then the outer cap or cover 31 is forced under pressure over the outer surface of the upper end
70 of the tube or cylinder 3. In this manner the tube 3 is made stiff and rigid by being clamped tightly between the flange of the inner cap or cover 22 and the flange of the outer cap or cover 31.

The cap or cover 31 is preferably pro-
75 vided with a plurality of holes 39 to permit of the free circulation of air over the resistance coil 26, thus inclosed within a chamber between the inner and outer caps or covers 22 and 31, respectively. 80

In Fig. 3 is shown a modified form of induction coil in which the lead 19 is attached directly to the metal cap 22 by a bolt 40 and metal washer 41, and the adjacent end of a
85 spiral resistance coil 26, preferably of nickel wire, is clamped by a nut 42 on said bolt 40, between a metal washer 43 and the top of the cover 22. The other end of the coil 26 is, however, clamped between insulating
90 washers 44 and 45 surrounding the ends of an insulating bushing 46 passing through the cover 22 and through which a bolt 47 passes. A nut 48 on the end of the bolt 47 holds the end of the resistance coil firmly
95 on but insulated from the inner cap 22. In this case the lead 38 may extend through a bushing 49 of insulating material through the outer cap 31 and is held clamped in electrical engagement with the end of the
100 resistance coil 26 by the bolt 47.

In Fig. 5 is shown a still further modified form of the device. In it the inner cap 22 is provided with an insulating washer or
105 bushing 50 through which the lead 19 passes. In this manner the inner cap 22 is completely insulated from the lead 19, from the induction coil and is also insulated from the resistance coil 26.

In Fig. 6 is a further modified form. The lead 19 is in this instance soldered directly
110 to the under side of the inner cap 22 and one end of the resistance coil 26 is soldered to the top of the cap or cover 22. In this manner the inner cap is made a part of the conductor of the primary circuit and the
115 passing of the lead 19 through the inner cap 22 is obviated.

Sometimes it is desirable to lead the ground wire 10 through the outer cap 31 and this arrangement is shown in Fig. 7 in
120 which the inner cover 22 is provided with an insulating bushing 51 and the outer cap 31 is provided with an insulating bushing 52 through which the lead 10 is conducted to the outside of the casing. In this modi-
125 fied form of the invention the resistance coil 26 and the lead 19 are shown as soldered, respectively, to the opposite sides of the inner cap 22, as in Fig. 6.

When it is desired so to do the resistance 130

26 may be omitted, as shown in Fig. 8, and the inner and outer caps 22 and 31, respectively, are made without openings or outlets, but they are similarly forced into and
 5 outside of the tube 3, respectively, and serve the purpose of stiffening the tube 3. The lead 19 of the primary coil 1 may be taken out through a bushing 53 in the side of the tube 3. In the same manner the leads 10
 10 and 11 may be taken out through the side of the tube 3 through bushings 54 and 55, respectively.

The induction coils above described are particularly adapted for use in normally
 15 closed sparking circuits of internal combustion engines, that is to say, in systems in which the primary circuit is held normally closed, and the spark is caused by a current induced in the secondary coil by breaking
 20 the primary circuit. Resistance 26 serves to control or limit the current in the primary winding of the induction coil.

By tightly forcing the flanged disk 4 within the ring 6 over the outside of the tube 3,
 25 and the flanged disk 23 within and the outer cover or cap 31 over the outside of the tube 3, the whole tube or casing 3 is made very stiff and rigid. The parts are permanently united together without cement, screws, or
 30 any other fastening devices, for the friction between the tube and the said parts serves to hold the parts rigidly and permanently together, making other fastening means unnecessary.

35 While I have referred to the use of solidified or congealed paraffin in which the coil is embedded and covered, any other suitable insulating material may be substituted therefor as occasion might make expedient.

40 The inner heads 4 and 22, the ring 6 and the outer cap 31 are preferably stamped from sheet metal and their flanges snugly fit the adjacent surfaces of said tube 3 into engagement with which they are forced un-
 45 der considerable pressure.

This application is a substitute for or continuation of application Ser. No. 131,749, filed November 16, 1916.

What I claim is:

50 1. Induction coil structure comprising an inclosing casing, an induction coil therein, a cap on one end of said casing, and a resistance element connected in series with the primary of said induction coil disposed be-
 55 tween said cap and said induction coil.

2. Induction coil structure comprising an inclosing casing, an induction coil therein, a perforated cap on one end of said casing, and a resistance element connected with the
 60 primary of said induction coil disposed between said cap and said induction coil.

3. Induction coil structure comprising an inclosing casing, an induction coil therein, a cap on one end of said casing, a resistance
 65 element in series with the primary of said

induction coil disposed between said cap and said induction coil, and a primary terminal carried by said cap.

4. Induction coil structure comprising an inclosing casing, an induction coil therein, 70 a cap on one end of said casing, a resistance element connected with the primary of said induction coil disposed between said cap and said induction coil, and a primary terminal carried by said cap and connected to 75 said resistance element.

5. Induction coil structure comprising an inclosing casing, an induction coil therein, a lead common to the primary and secondary coils of said induction coil extend- 80 ing through the side of said casing, a connection to the other terminal of said secondary extending through the side of said casing, a cap on said casing, a resistance element disposed between said cap and said 85 induction coil, a terminal carried by said cap, and a connection from the other terminal of said primary coil to said terminal on said cap through said resistance element.

6. Induction coil structure comprising an inclosing casing, an induction coil therein, 90 a lead connected with one terminal of the primary coil extending through the side of said casing, a connection to a terminal of the secondary coil extending through the 95 side of said casing, a cap on said casing, a resistance element disposed between said cap and said induction coil, a terminal carried by said cap, and a connection from the other terminal of said primary coil to said 100 terminal on said cap through said resistance element.

7. Induction coil structure comprising an inclosing casing of insulating material, an induction coil therein, metallic caps engag- 105 ing said casing internally and externally and insulated from each other by said casing, and a resistance element in the space between said caps and connected with the primary of said induction coil. 110

8. Induction coil structure comprising an inclosing casing of insulating material, an induction coil therein, metallic caps engag- 115 ing said casing internally and externally and insulated from each other by said casing, a resistance element in the space between said caps, and a terminal carried by the external cap and connected with the primary of said induction coil through said re- 120 sistance element.

9. Induction coil structure comprising an inclosing casing, an induction coil therein, a cap on said casing, a metallic member be- 125 tween said cap and said induction coil forming an end closure for said casing, a support of insulating material carried by said metallic member and disposed between it and said cap, and a resistance element disposed upon said insulating support and connected with the primary of said induction coil. 130

10. Induction coil structure comprising an inclosing casing, an induction coil therein, a cap on said casing, a metallic member between said cap and said induction coil forming an end closure for said casing, a support of insulating material carried by said metallic member and disposed between it and said cap, a resistance element disposed upon said insulating support, a terminal carried by said cap, and a connection from said terminal to the primary of said induction coil through said resistance element.

11. Induction coil structure comprising an inclosing casing, an induction coil therein, a cap on said casing, a metallic member between said cap and said induction coil forming an end closure for said casing, a conducting member carried by and insulated from said metallic member, a support of insulating material held by said conducting member and disposed between said cap and said metallic member, and a resistance element carried by said supporting member and connected with the primary of said induction coil.

12. Induction coil structure comprising an inclosing casing, an induction coil therein, a cap on said casing, a metallic member between said cap and said induction coil forming an end closure for said casing, a conducting member carried by and insulated from said metallic member, a support of insulating material held by said conducting member and disposed between said cap and said metallic member, a resistance element carried by said supporting member, a terminal carried by said cap, and a connection from said terminal to the primary of said induction coil through said resistance element.

13. Induction coil structure comprising an inclosing casing having two chambers, one of said chambers containing an induction coil, and the other of said chambers containing a resistance element for limiting the flow of current to said induction coil.

14. Induction coil structure, for use in an ignition system of a motor vehicle, comprising an inclosing casing having two chambers, one of said chambers containing an induction coil, and the other of said chambers containing a resistance element for limiting the flow of current to said induction coil.

15. Induction coil structure comprising an inclosing casing having two chambers, one of said chambers containing an induction coil, and the other of said chambers containing means for limiting the flow of current to said induction coil.

16. An induction coil unit comprising the combination of a casing comprising a cylindrical tube of insulating material, inner sheet metal heads each having a cylindrical flange forced into opposite ends, respectively, of said tube, with the outer surface

of said flanges in tight frictional engagement with the interior surface of the ends of said tube, and outer sheet metal end members each having a cylindrical flange forced over the ends, respectively, of said tubes with the interior surface of said flanges in tight frictional engagement with the exterior surface of the ends of said tube, an induction coil within said casing, and insulating material filling the space between said coil and said casing and inclosing said coil.

17. An induction coil unit comprising the combination of a cylindrical tube of insulating material, a disk of sheet metal having a cylindrical flange forced into one end of said tube with the outer surface of said flange in tight frictional engagement with the inner surface of the end of said tube, an outer member having a cylindrical flange forced over said end of said tube with the inner surface of said flange in tight frictional engagement with the outer surface of said tube, a member of insulating material within said tube and positioned on the inner surface of said flanged disk, and an induction coil in said tube resting on said sheet.

18. An induction coil unit comprising the combination of a cylindrical tube of insulating material, a sheet metal disk having a cylindrical flange tightly forced into one end of said tube, an outer member having a cylindrical flange tightly forced over said end of said tube, said disk and said outer member being fixedly retained in position by the friction between them and said tube, an induction coil in said tube embedded in congealed insulating material, poured in a fluid condition into the space between said coil and said tube, a metal disk having a cylindrical flange tightly forced into the other end of said tube, and an outer cap of sheet metal having a cylindrical flange forced over said last mentioned end of said tube, said last mentioned metal disk and said outer cap being permanently retained on said tube by the frictional engagement between them and said tube.

19. An induction coil unit comprising the combination of a cylindrical tube, a head forced into one end of said tube having its outer surface flush with the end of said tube and a ring member forced over the outer surface of said end of said tube, an induction coil within said tube and surrounded by insulating material, a head forced into the other end of said tube with its outer surface substantially flush with the other end of said tube and a cap forced over the said last mentioned end of said tube, said heads, cap and ring being retained permanently to said tube by friction between them and said tube, and serving to make said paper tube stiff and rigid.

20. An induction coil unit comprising the combination of an insulating tube, flanged

heads of sheet metal tightly forced into opposite ends of said tube, a flanged ring of rigid material tightly forced over the exterior surface of one end of said tube, a cap of sheet metal provided with a cylindrical flange tightly forced over the other end of said tube and providing a chamber between said cap and the head forced into that end of said tube, an induction coil contained within said tube, a binding post secured to said tube intermediate the ends thereof, a terminal of the secondary winding of the said coil being attached to said binding post, and a terminal of the primary winding of said induction coil passing through said cap and the head in the same end of said tube.

21. An induction coil unit comprising the combination of a tube, an induction coil mounted therein, a flanged metal cap extending over the outer surface of said end of said tube and providing a chamber between said cap and said induction coil, and a resistance mounted in said chamber and connected in series with the primary winding of said induction coil.

22. An induction coil unit comprising the combination of a tube of insulating material closed at one end, an induction coil within said tube, a diaphragm in the end of said tube, a cap extending over the outer surface of said end of said tube and providing a chamber between said cap and said diaphragm, and a resistance mounted within said chamber in series with the primary winding of said coil, said cap being provided with openings for circulation of air through said chamber.

23. In an ignition sparking means for an ignition system for use in a motor vehicle, the combination of an induction coil hermetically embedded in insulating material, a cylindrical tube of insulating material surrounding said embedded coil, flanged metal disks with the flanges thereof tightly forced within the opposite ends of said tube, a flanged ring with the flange thereof tightly forced over one end of said tube, a flanged

cap with the flange thereof tightly forced over the other end of said tube, whereby said tube and said flanged disks, said ring and said cap are permanently and rigidly frictionally secured together, and a resistance coil connected in the primary circuit of said induction coil and mounted upon one of said flanged disks between said flanged disk and said flanged cap.

24. A unitary sparking device for ignition systems used in motor vehicles, comprising an induction coil hermetically embedded in congealed insulating material, a rigid tube of insulating material surrounding said embedded coil, circular flanged members tightly forced within and over the ends of said tube for frictionally, permanently and rigidly securing said members to said tube, and a resistance connected in the primary circuit of said induction coil inclosed in a space formed between two of said flanged members.

25. A unitary ignition sparking device for use in an ignition system of a motor vehicle, comprising an induction coil hermetically embedded in congealed insulating material, a tube of insulating material surrounding said coil, spaced end heads respectively internally and externally telescopically forced in and over the ends of said tube for permanent and rigid connection thereto, a resistance element mounted upon one of said heads in the space formed between said heads, and a primary circuit lead connected to said resistance element.

26. An ignition induction coil unit comprising the combination of a tubular casing, an induction coil therein, a diaphragm within and extending across said casing at one end of said induction coil, a cap on said casing spaced from said diaphragm to form a chamber, and a resistance disposed in said chamber and connected with the primary winding of said induction coil.

In testimony whereof I have hereunto affixed my signature this 30th day of June, 1921.

ARTHUR ATWATER KENT.