

E. F. W. ALEXANDERSON.
 MEANS FOR CONTROLLING ALTERNATING CURRENTS.
 APPLICATION FILED NOV. 26, 1915.

1,328,797.

Patented Jan. 20, 1920.
 3 SHEETS—SHEET 1.

Fig. 1.

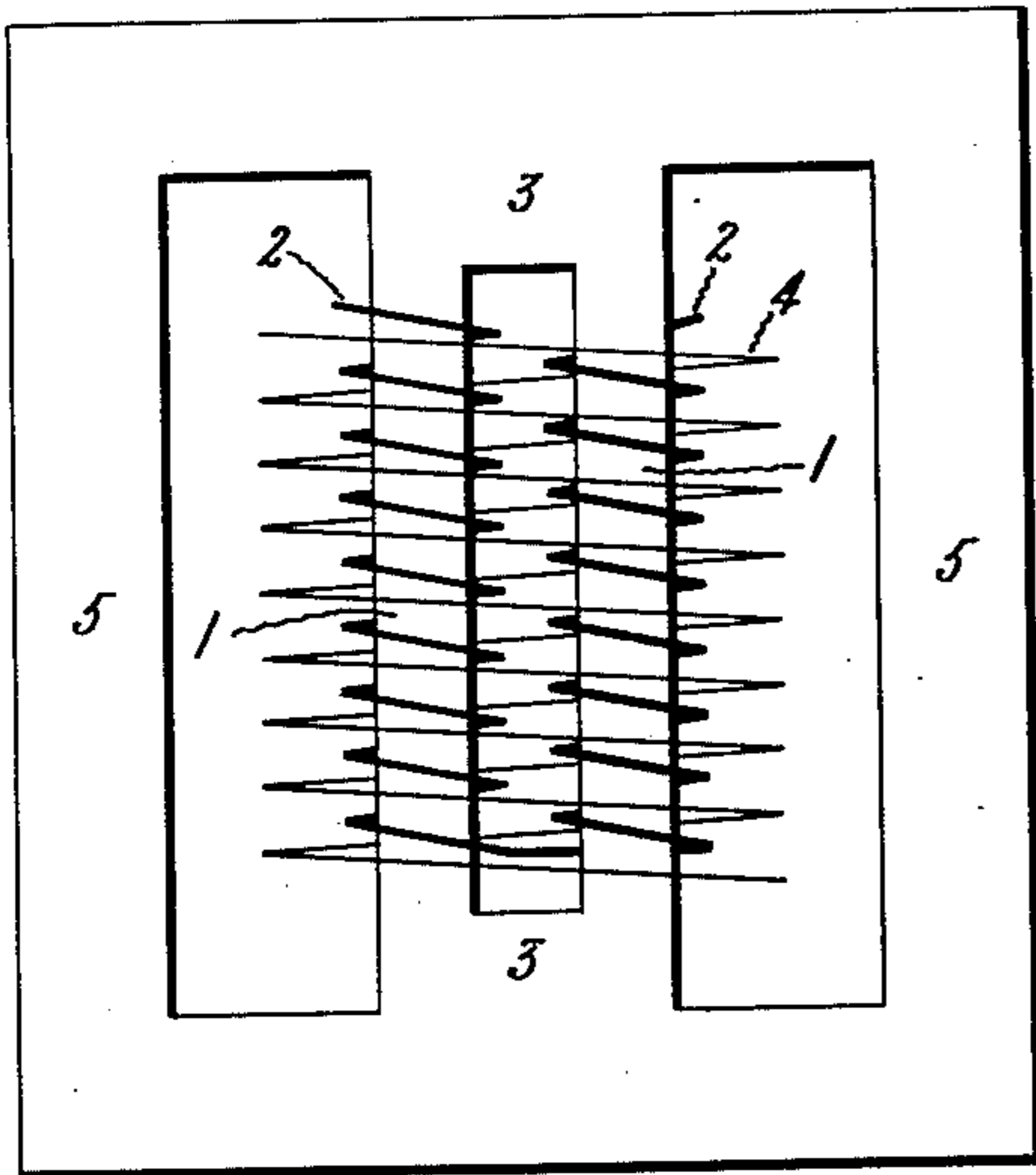

Fig. 3.

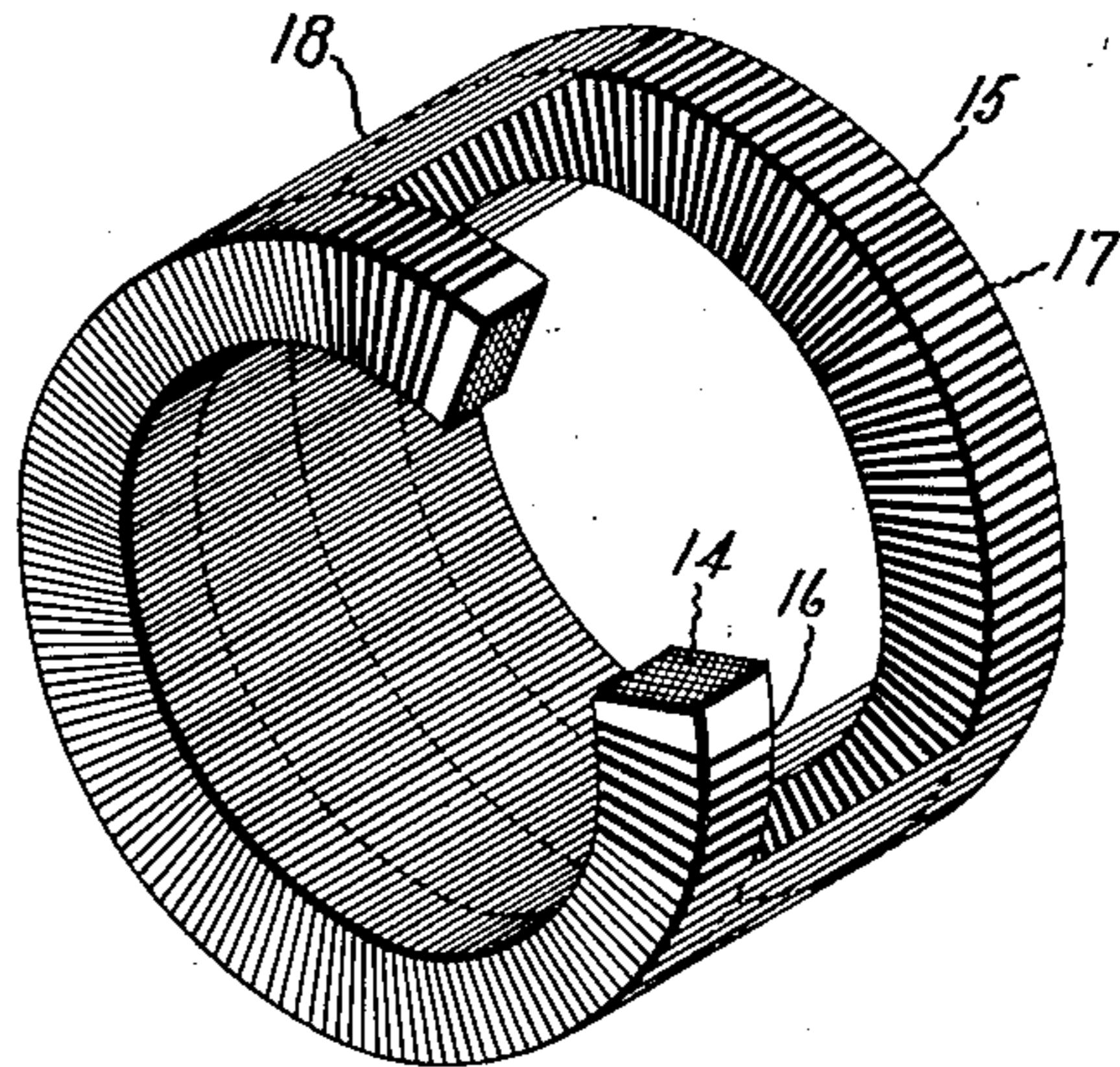
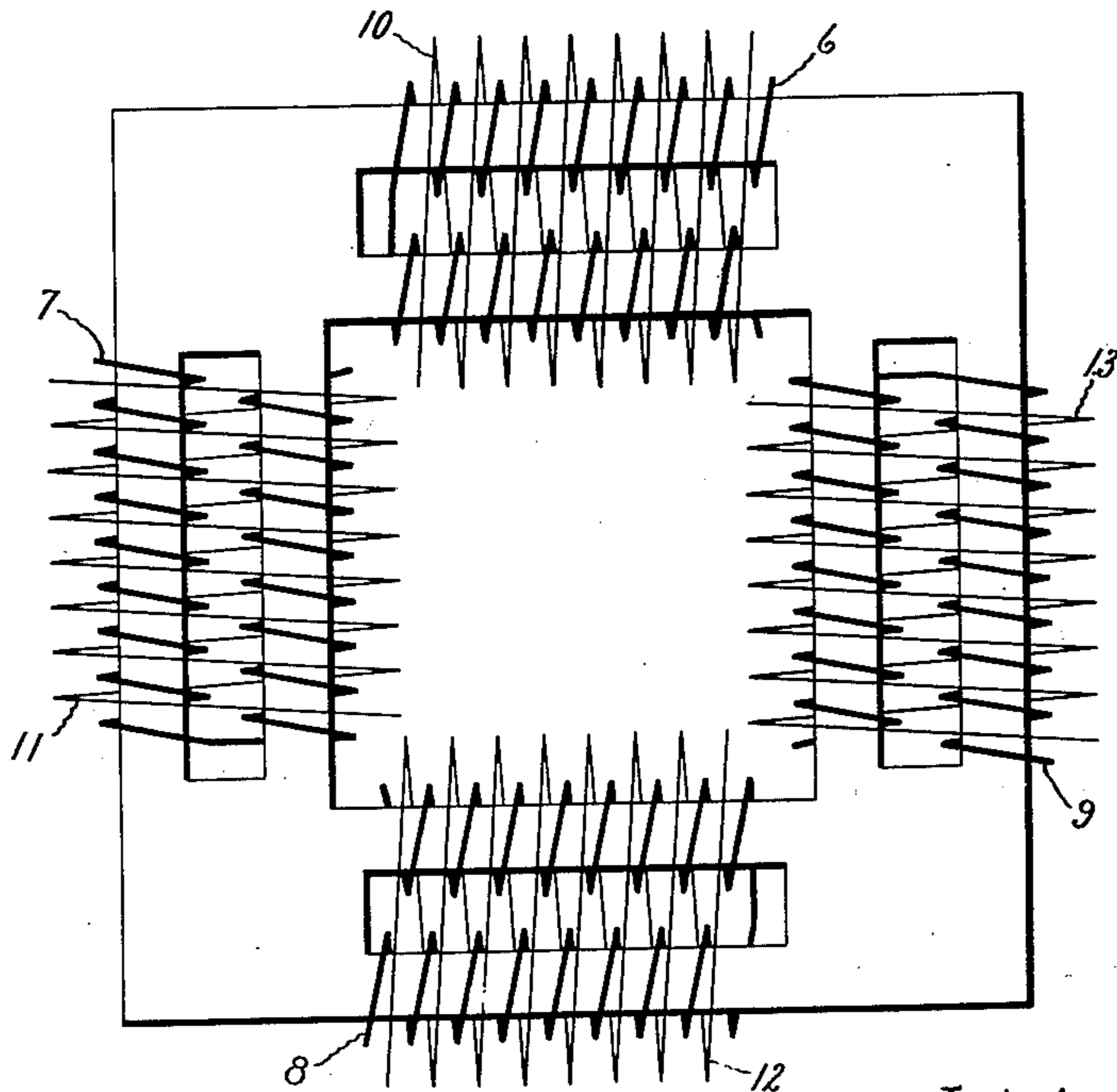

Fig. 2.



Inventor:
 Ernst F. W. Alexanderson,
 by *Alfred S. Davis*
 His Attorney.

E. F. W. ALEXANDERSON.
MEANS FOR CONTROLLING ALTERNATING CURRENTS.
APPLICATION FILED NOV. 26, 1915.

1,328,797.

Patented Jan. 20, 1920.

3 SHEETS—SHEET 2.

Fig. 4.

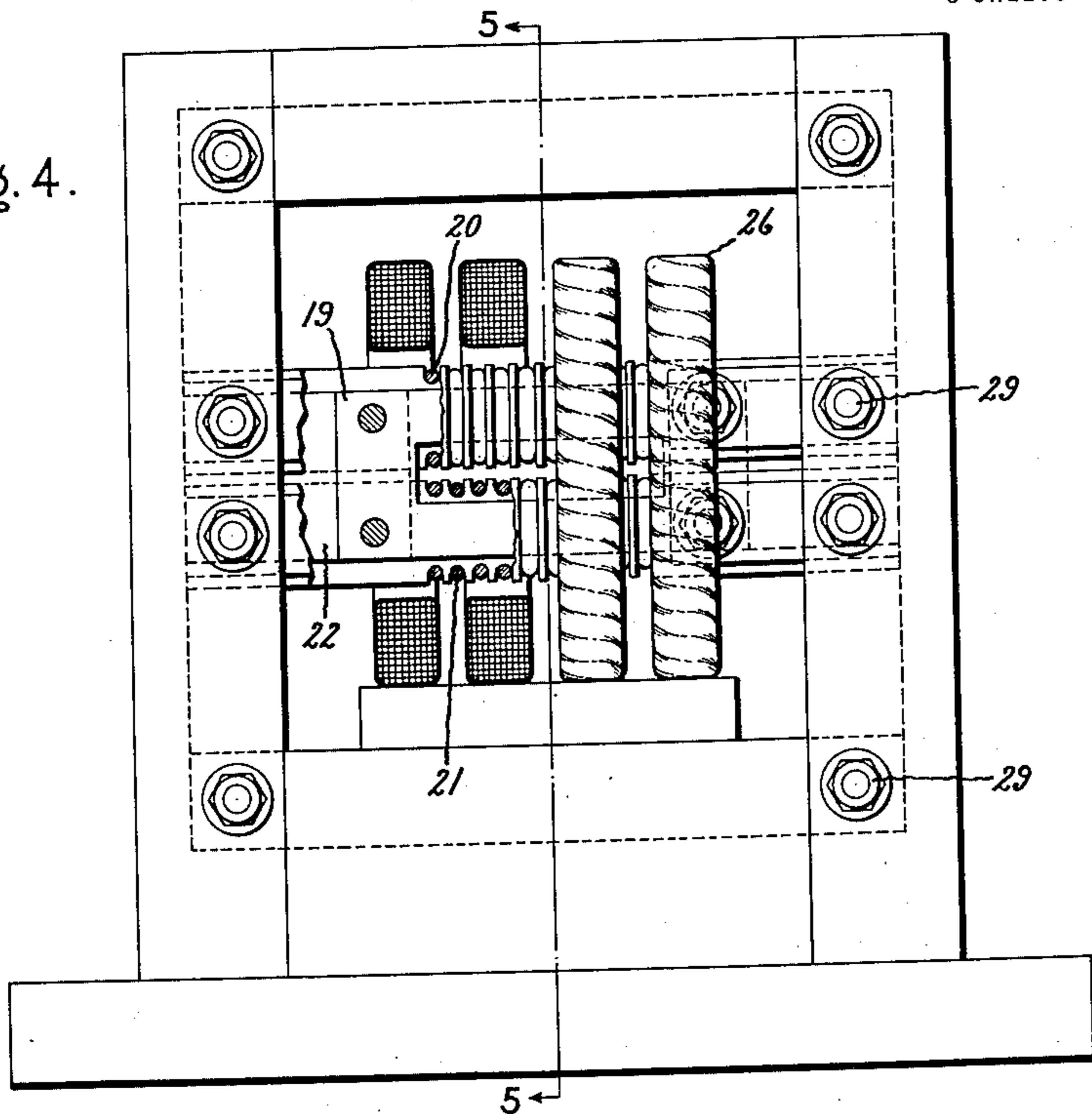
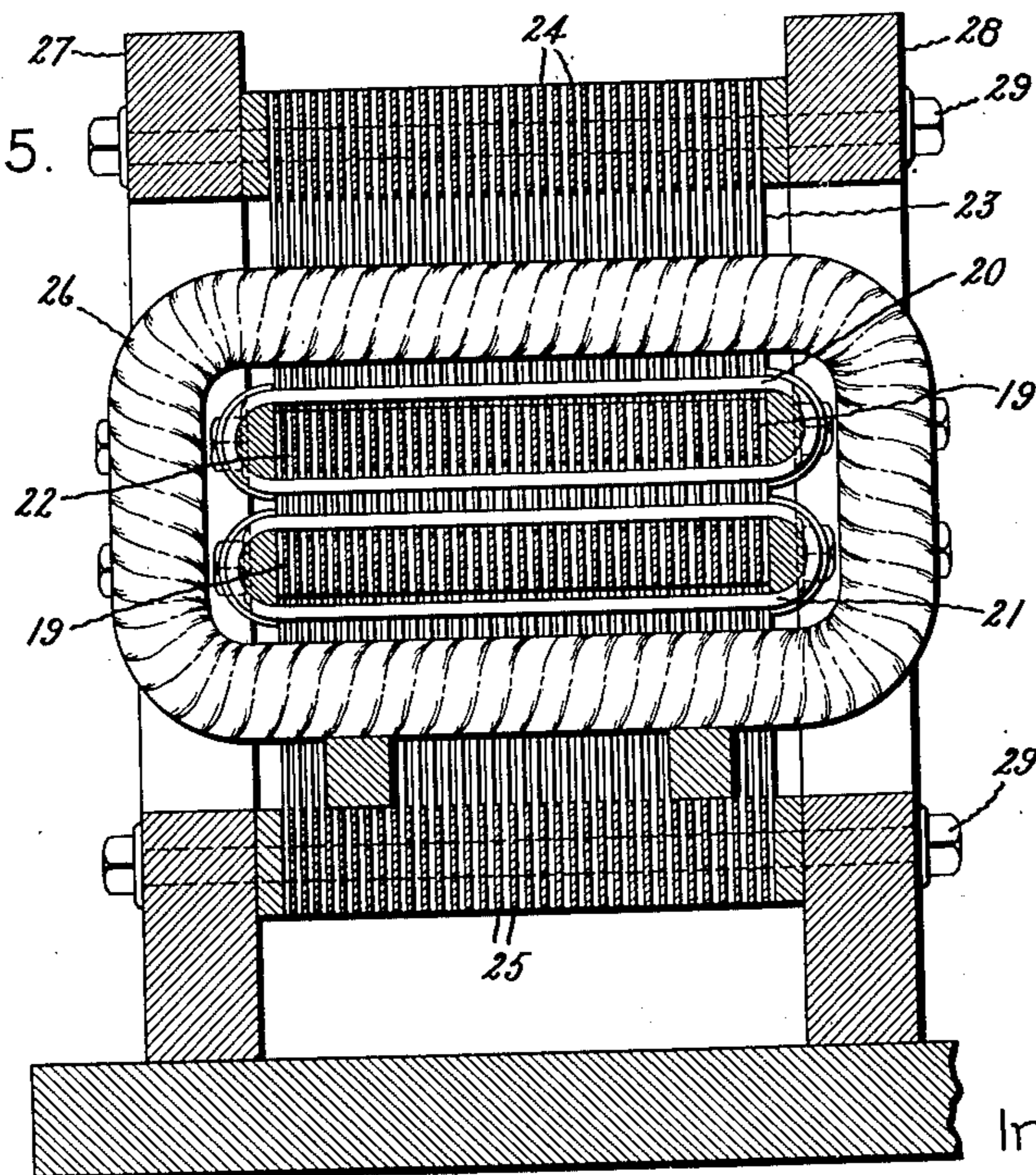

Fig. 5.



Inventor:
Ernst F. W. Alexanderson,
by *Wm. H. Davis*
His Attorney.

E. F. W. ALEXANDERSON.
 MEANS FOR CONTROLLING ALTERNATING CURRENTS.
 APPLICATION FILED NOV. 26, 1915.

1,328,797.

Patented Jan. 20, 1920.

3 SHEETS—SHEET 3.

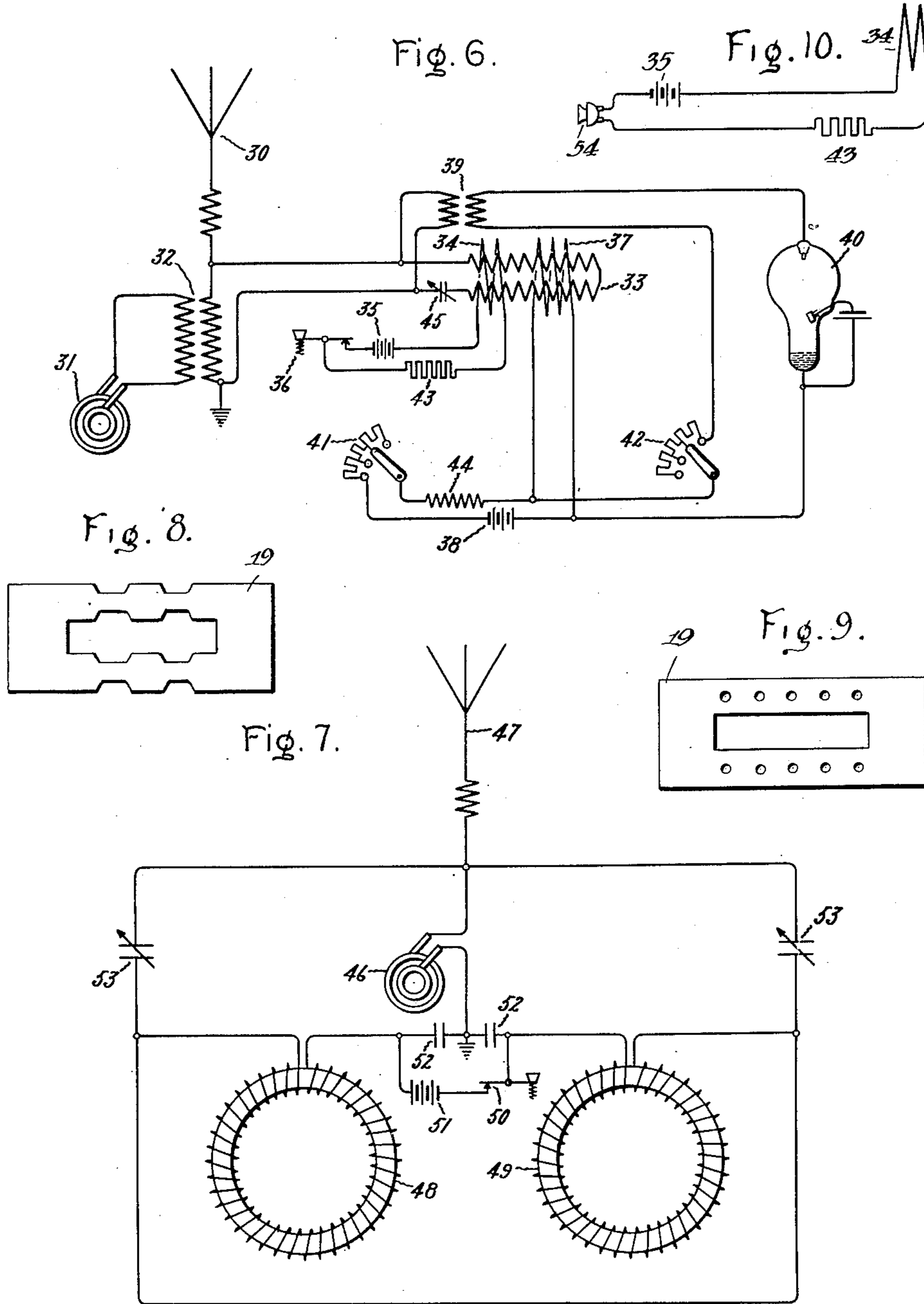

Inventor :
 Ernst F.W.Alexanderson,
 by *Alfred S. Davis*
 HisAttorney.

UNITED STATES PATENT OFFICE.

ERNST F. W. ALEXANDERSON, OF SCHENECTADY, NEW YORK, ASSIGNOR TO GENERAL ELECTRIC COMPANY, A CORPORATION OF NEW YORK.

MEANS FOR CONTROLLING ALTERNATING CURRENTS.

1,328,797.

Specification of Letters Patent.

Patented Jan. 20, 1920.

Application filed November 26, 1915. Serial No. 63,438.

To all whom it may concern:

Be it known that I, ERNST F. W. ALEXANDERSON, a citizen of the United States, residing at Schenectady, in the county of Schenectady, State of New York, have invented certain new and useful Improvements in Means for Controlling Alternating Currents, of which the following is a specification.

10 My present invention relates to electromagnetic apparatus for use with high frequency alternating currents either for controlling the flow of such currents in a circuit, for doubling the frequency thereof or
15 for similar purposes. More particularly my invention relates to electromagnetic apparatus of a kind which I term magnetic amplifiers, such for example, as are described in my U. S. Patent No. 1,206,643.

20 The object of my invention is to improve the construction of magnetic amplifiers of the class described in the above-mentioned patent in order to render them more efficient for the purpose for which they may be employed. The operation of such devices is
25 based upon the fact that the energy per cycle of high frequency currents is comparatively small and consequently the energy stored in the electromagnetic field of the generator circuit is comparatively low. As an amplifier of variable currents of comparatively
30 low frequency the device operates by modifying the magnetic field of the high frequency circuit in accordance with variations in the current to be amplified and inasmuch as the energy necessary to modify this magnetic field is proportional to the energy stored during each cycle it may be shown that it is possible to construct a magnetic
40 amplifier with a ratio of amplification equal to the ratio between the frequency of the high frequency current and that of the current which is to be amplified. When the frequency of the current which is to be amplified approaches zero the theoretically
45 possible ratio of amplification would thus approach infinity. The theoretical foundation for this principle of amplification is as follows:

50 The energy stored in a magnetic field is represented by the quantity $\frac{1}{2}Li^2$, where L is the coefficient of self-induction and i is the magnetizing current. If the current varies in accordance with the sine wave law,

the voltage induced at the terminals of the magnetizing winding is $2\pi fLi$, where f is the frequency and i is the effective or the root mean square of the alternating current. The magnetizing current i is a wattless current being 90° out of phase with the voltage and the voltampere or apparent power required to maintain an alternating current field at any particular frequency is thus $2\pi fLi^2$. It can be seen from the two above expressions for energy stored in the electric field and the apparent power required to maintain this field at any particular frequency that there is a definite numerical relation between the energy per cycle and the volt amperes needed for magnetization that depends upon the frequency only. Thus we can say generally that the voltamperes of magnetization equal 2π times frequency per second times energy stored in the magnetic field.

75 When my device is employed as an amplifier it is used as a high frequency impedance in order to control the flow of power from an alternator with constant field excitation or an equivalent source of high frequency power. The flow of power can be controlled either by inserting the impedance in series with the load or in shunt with the source of power, or by some combination of these methods. In either case the maximum
80 volt amperes which must be absorbed by the impedance is of substantially the same order of magnitude as the power flowing in the load circuit.

85 In the case of an inductive impedance like the device described the energy stored and released in the magnetic field during each half-cycle is of the same order of magnitude as the power flow in the main circuit. The method of controlling the inductive impedance is to superimpose another flux in the same magnetic structure. The controlling flux saturates the iron and thereby limits the pulsations of the high frequency flux. The controlling flux must, therefore,
90 be of the same order of magnitude as the high frequency flux and the energy stored in the magnetic field of the controlling flux is, therefore, of the same order as the high frequency flux. If the controlling flux is constant no energy flow is needed in the controlling circuit and the rate of amplification may theoretically be infinity. If, however,
105

the controlling flux pulsates with some definite frequency or combination of several frequencies there must be an energy flow in the magnetizing winding of the control flux
 5 in order to change the amount of energy stored in the same flux. This flow of energy is substantially wattless inasmuch as the energy during the first part of each half-cycle is returned during the second part of the same
 10 half-cycle. However, the current necessary for this transfer of energy is of a character of an ordinary wattless magnetizing current. It may be seen from the preceding that the voltamperes consumed by this controlling magnetizing current must transfer
 15 during each cycle of its pulsations an amount of energy corresponding to the change in energy stored in the controlling field and consequently the voltamperes
 20 needed for magnetization of the control winding are as much lower than the high frequency power that is being controlled as the frequency of the control pulsations is lower than the radio frequency. The ratio
 25 of amplification is, therefore, the same as the ratio of these two frequencies.

Electro-magnetic devices of the present class may be developed in a variety of forms, taking into account the principles as
 30 above explained. The preferred form is that in which the structure consists of a magnetic circuit with a high frequency winding interlinked therewith and a controlling winding so related to the high frequency
 35 winding that there will be substantially no flow of high frequency current in the controlling winding. This may be accomplished either by making the controlling winding inductively independent of the
 40 flux induced by the high frequency winding or by so arranging the windings that the controlling winding has one portion interlinked with the high frequency flux in one direction and another equal portion inter-
 45 linked with the high frequency flux in the opposite direction so that the induced potentials are neutralized in the winding itself.

The features of my invention which I consider novel are pointed out with particularity in the appended claims. The invention
 50 itself, however, together with further objects and advantages will best be understood by reference to the following description taken in connection with the accompanying
 55 drawings in which Figures 1, 2 and 3 show diagrammatically as many modifications of my invention; Fig. 4 is an elevation of a structure in which the magnetic circuits and windings are as shown in Fig. 1; Fig. 5 is
 60 a vertical section taken on the line 5—5 of Fig. 4; Figs. 6 and 7 show systems in which my invention may be utilized; Figs. 8 and 9 show modified forms of elements which may be used for building up the device shown in

Figs. 4 and 5, and Fig. 10 is a diagram 65 showing how the system of Fig. 6 may be modified in such a way that it may be used for telephony instead of telegraphy.

In the form of my invention shown in Fig. 1 two magnetic cores 1 are provided 70 with windings 2 for carrying the high frequency current. The windings are so arranged that the flux is in opposite directions in the two cores and as a result the high frequency flux flows only through the cores 1 75 and through small portions 3 of the structure adjacent the cores. A second winding 4 which is adapted to carry the controlling current is wound around both of the cores as indicated. The flux produced by this 80 winding traverses the two cores in the same direction and also traverses the outer legs 5 of the magnetic structure. It will be apparent that each turn of this controlling winding is threaded by the flux in the two 85 cores 1 in opposite directions so that any electromotive forces induced in the winding by the high frequency flux are neutralized in each turn. It will also be noted that the controlling winding covers substantially the 90 entire length of the high frequency magnetic circuit.

In the form of my invention shown in Fig. 1 it will be seen that the controlling winding has to produce a flux through a 95 comparatively long magnetic circuit and that the high frequency flux passes through only a small part of this circuit. This may not offer any serious objection as the portion of the magnetic circuit not linked with 100 the high frequency flux is of large cross-section and the ampere turns required to force a great enough flux through this portion to saturate the cores 1 would be comparatively small. In case, however, this 105 feature should be objectionable it can be largely avoided by the form shown in Fig. 2 in which four high frequency windings 6, 7, 8 and 9 are employed as indicated to produce a flux in each pair of cores in the same 110 way that the flux is set up in the single pair of cores in Fig. 1. The controlling windings 10, 11, 12 and 13 are connected in series so that the flux produced by all of them is in the same direction. The operation will be 115 the same as in the form shown in Fig. 1 and the only material which must be magnetized by the controlling current and which is not traversed by the high frequency flux is a small portion at each corner. 120

In case it is desirable to have all of the material in the magnetic circuit threaded by both fluxes the two magnetic cores may take the form of two rings 14 and 15, as shown in Fig. 3 with high frequency windings 16 125 and 17 respectively so arranged that the high frequency flux is in opposite directions in the two rings. A controlling winding 18,

a portion of which, for convenience in illustration, is not shown, surrounds the two rings and the windings thereon.

In the operation of my invention, if the control flux is great enough to saturate or almost saturate the high frequency core the permeability of the magnetic circuits is changed and the impedance of the high frequency circuit is modified accordingly. The object of the present design of amplifier is to get as effective control of the high frequency current as possible by producing a variation of impedance over a wide range in the high frequency winding. In any transformer structure there is a certain amount of leakage in the air surrounding the winding which creates a leakage reactance in addition to the reactance of the flux in the iron core. This leakage reactance in air cannot be controlled because the permeability of air is constant. Hence the greater the leakage reactance the less efficient the control. Also since the volt amperes required to produce this leakage flux is of no effect in controlling the high frequency current the degree of amplification is reduced because of this leakage. In the present case I have reduced the leakage reactance to a minimum by bringing the two windings as close together as possible and making the controlling winding cover substantially the entire length of the high frequency magnetic circuit.

In Figs. 4 and 5 I have illustrated a practical construction for a device embodying the form of my invention illustrated in Fig. 1. In constructing electromagnetic devices of the class under consideration it is customary to build up the cores with thin sheets of magnetic material, separated by insulating layers to avoid excessive eddy current losses. When iron such as is usually employed for ordinary frequencies is used with high frequency current the skin effect is appreciable, or, in other words, the apparent permeability of such iron with radio frequencies is much less than with low frequencies. In order to produce a certain flux it is, therefore, necessary to use a correspondingly greater amount of iron. The controlling current flux which is needed to saturate the iron will also be correspondingly greater. The degree of amplification depends upon the ratio between the high frequency energy controlled and the energy necessary to produce the saturating flux. If the saturating flux is greater on account of such skin effect the amplification is therefore correspondingly smaller.

In order to overcome this skin effect and obtain an increased efficiency in the amplifier, I may use an iron scale which is obtained in the annealing of silicon steel. This scale is about one and one-half mils in thickness and has high resistance. These

characteristics tend toward reducing the skin effect, in fact, it has been found by careful tests that skin effect is entirely absent at ordinary radio frequencies. I have found also that sheets of other magnetic material such as electrolytic iron or silicon steel may be made thin enough so that they have no appreciable skin effect at radio frequencies.

The losses in a device of this nature which appear in the form of heat are considerable and therefore it is desirable that the magnetic core should be well cooled. In building up a core of thin flexible sheets such as those which I prefer to use however, it is difficult to provide ventilating spaces between laminations in the usual way. To overcome this difficulty I first build up elements for the core structure by fastening together by means of an adhesive alternate sheet of iron and paper or other insulating material of the desired shape and size until a rigid body is formed and one which is not too thick to radiate the heat easily from the inner layers. In practice I find that about one-sixteenth of an inch is a suitable thickness for these elements. As shown in Figs. 4 and 5, the elements 19 which form the high frequency magnetic circuit have the shape of a hollow rectangle with the high frequency windings 20 and 21 around the two sides of the rectangle. In building up the core these elements 19 are interleaved with the short rectangular elements 22 at their ends and these elements in turn are interleaved with the elements 23 which form the sides of the magnetic circuit for the controlling flux. The elements 24 and 25 which form the top and bottom of the magnetic circuit are also interleaved between the side elements. With this arrangement it will be seen that spaces are provided for ventilation or for the circulation of a cooling fluid between all of the elements making up the complete structure. The controlling winding is also made up of a plurality of coils 26 with spaces between. The magnetic structure with the coils thereon is held firmly in place between the frame members 27 and 28 by means of bolts 29. Since the high frequency flux is confined almost entirely to the elements 19 and the other elements carry only the controlling flux of comparatively low frequency it is not essential that these elements be made of as thin laminations as the elements 19. Similar methods of construction may equally well be employed with the other forms of my invention shown in Figs. 2 and 3. When the core is in the form of a ring it may be made by winding continuous strips of magnetic material and insulating material to form cylindrical elements of different diameters with spacers between adjacent elements for cooling. Instead of using separate strips of insulating

material and magnetic material the latter may be coated with insulating material and the sheets or strips thus coated built up into elements. In some cases it may be desirable
 5 to build up the high frequency magnetic core of alternate portions of smaller and larger cross-section so that the smaller cross-sections will determine the saturation and the larger cross-sections will tend to reduce
 10 the magnetizing current when the core is not saturated, thus artificially increasing the range of permeability of the combined structure. In Fig. 8 I have shown a form
 15 in which the elements 19 of Figs. 4 and 5 may be constructed in order to accomplish this result. The same result may be obtained by perforating these elements in the manner indicated in Fig. 9. The novel features residing in the construction of the
 20 magnetic core are claimed in my application, Serial No. 283,306, filed March 18, 1919, which is a division of this application.

In Fig. 6 I have shown a transmitting system for wireless telegraphy which illustrates one way in which my invention may be employed. In this case the antenna 30 is supplied with high frequency current by means of the alternator 31 and the inductive coupling 32. The high frequency winding
 30 33 of a magnetic amplifier is connected in shunt to the coupling 32. Controlling winding 34 is supplied with current by the battery 35 when the telegraph key 36 is closed as indicated. A second controlling winding
 35 37 has connected thereto a battery 38 in such a direction that it will tend to send current through the winding in the same direction that current flows through winding 34. A second source of direct current may be
 40 obtained by rectifying the high frequency current in the secondary of transformer 39 by means of rectifier 40. These two currents may be balanced by means of the rheostats 41 and 42. When the high frequency voltage
 45 is at a maximum the rectified current should be equal and opposite to the current derived from battery 38 so that the resulting current in winding 37 will be zero. When on the other hand the high frequency
 50 voltage is at a minimum the high frequency current is also at a minimum and approximately all of the current derived from battery 38 is effective in increasing the saturation of the core produced by the current in
 55 the telegraph circuit. With this arrangement, when the key 36 is opened the permeability of the magnetic circuit is lowered and the impedance of winding 33 increases and the flow of current therethrough decreases.
 60 As a result the high frequency voltage is increased and the rectified current in increased accordingly. The current from battery 38 through controlling winding 37 then becomes less and there is a further increase in
 65 the impedance of winding 33 and in the

high frequency potential. By proper regulation of the circuits the amplifier may be made practically self exciting in this way so that a very feeble telegraph current will be able to cause a complete change from
 70 minimum to maximum voltage. The resistance of rheostat 42 should preferably be large and the inductance of winding 37 small in order that the circuit will respond
 75 quickly to changes in the voltage derived from transformer 39. The circuit supplying controlling winding 34 should also preferably have a high resistance in comparison to its inductance. In case this circuit comprises a long telegraph line this condition
 80 will usually be present. In case however it merely consists of a local circuit as indicated a resistance 43 may be placed in the circuit. The circuit supplied by battery 38 should have a high inductance and this
 85 may be secured by the use of an extra inductance 44 as indicated.

The amplifying effect may also be increased by inserting an adjustable condenser 45 in series with the high frequency winding in order that the impedance of the shunt circuit may be reduced to a minimum when the current is the maximum.

In some cases it may be desirable to use the same winding for both the high frequency
 95 circuit and the controlling circuit. One way in which this may be done is illustrated in Fig. 7. In this instance the high frequency generator 46 is connected in series with the antenna 47 and two high frequency
 100 windings in shunt to the generator surround the rings 48 and 49. When key 50 is closed the battery 51 sends current through the two windings in series. With this arrangement it will be evident that the ampere turns of
 105 the high frequency winding are linked as closely as possible with the ampere turns of the controlling winding and that the high frequency electromotive forces in the controlling circuit being equal and opposite to
 110 each other no high frequency currents will flow through the battery 51 when key 50 is closed. Condensers 52 inserted in the high frequency circuits prevent the short-circuiting of the battery 51 and variable condensers
 115 53 may be used to increase the amplifying effect as in the arrangement shown in Fig. 6. This modification of my invention is described and claimed in my copending application, Serial No. 229,686, filed April
 120 20, 1918, which is a continuation in part of the present application.

While in the above illustrations I have described a method of amplifying telegraphic signals it will be apparent that the same
 125 principle may equally well be adapted for transmitting signals of other character such, for example, as telephone currents. In Fig. 10 I have shown a modification of the arrangement shown in Fig. 6 in which a tele- 130

phone receiver 54 is substituted for the telegraph key 36 in order to adapt the system for transmitting telephone signals. A telephone receiver may equally well be substituted for the telegraph key 50 in the arrangement shown in Fig. 7. It will also be apparent that many modifications in the structure of the apparatus and in the application thereof may be made without departing from the scope of the appended claims.

What I claim as new and desire to secure by Letters Patent of the United States, is:—

1. Means for controlling the flow of a high frequency current comprising an electromagnetic device having a closed magnetic circuit with two cores, windings for producing fluxes in both of these cores by means of the high frequency current and by means of a controlling current and a second magnetic circuit, which includes the two cores of the first circuit in parallel, and which is traversed by the flux produced by the controlling current, the windings being so arranged that at any given instant the two fluxes are in the same direction in one core and in opposite directions in the other core, and that voltages induced from the high frequency flux in the winding of the controlling current are neutralized in that winding.

2. Means for controlling the flow of high frequency current comprising an electromagnetic device having a closed magnetic circuit with two cores, a winding on these cores for producing a flux therein by means of the high frequency current, a second magnetic circuit which includes the two cores of the first circuit in parallel, a winding for producing a flux in the second magnetic circuit by means of a controlling current, the windings being so arranged that at any given instant the two fluxes are in the same direction in one core and in opposite directions in the other core, and the turns of the controlling current winding being uniformly distributed and covering the high frequency current winding on all parts of the cores where the latter winding is placed.

3. An electromagnetic device having a closed magnetic circuit, a magnetizing winding for said circuit adapted to carry a high frequency alternating current, a second magnetizing winding for said circuit adapted to carry a controlling current, the controlling winding interlinking the high frequency winding in such a way that the high frequency electromotive forces induced therein are neutralized in each turn and covering substantially the entire length of the magnetic circuit of the high frequency winding.

4. Means for controlling the flow of high frequency current comprising an electromagnetic device, having two cores both traversed by a flux produced by the high frequency current and by a flux produced by

a variable controlling current, each turn of the controlling winding interlinking a pair of turns of the high frequency winding in opposite directions and the controlling winding covering substantially the entire length of the high frequency magnetic circuit.

5. Means for controlling the flow of high frequency current comprising an electromagnetic device having two cores both of which are traversed by a flux produced by the high frequency current and by a second flux produced by a controlling current, the circuit of the controlling current interlinking the two portions of the high frequency circuit in opposite directions and covering substantially the entire length of the high frequency magnetic circuit.

6. Means for controlling the flow of high frequency current comprising an electromagnetic device having two cores both of which are traversed by a flux produced by the high frequency current and by a second flux produced by a controlling current, the windings which produce these fluxes being so arranged that the high frequency induction is not effective in the circuit supplying the controlling winding and the controlling winding being distributed so as to cover substantially the entire length of the magnetic circuit of the high frequency flux.

7. An electromagnetic device having a closed magnetic circuit, the apparent permeability of which is substantially independent of the frequency of the magnetizing current, a magnetizing winding for said circuit adapted to carry a high frequency alternating current and a second magnetizing winding for said circuit adapted to carry a controlling current, the windings being so related to each other that substantially no high frequency current will flow in the circuit supplying the controlling winding.

8. Means for controlling the flow of high frequency current comprising an electromagnetic device having a closed magnetic circuit the apparent permeability of which is substantially independent of the frequency of the magnetizing current, certain portions of said device being traversed by a high frequency flux in one direction and by a controlling flux in the opposite direction, other portions being traversed by the fluxes in the same direction and the winding which produces the controlling flux being distributed so as to cover substantially all of the device which is traversed by the high frequency flux.

9. An apparatus of the character described comprising a single magnetic circuit made up of two parallel magnetic cores, means for producing a radio frequency magnetic flux which flows in opposite directions in said cores, means for producing a

controlling flux which flows in the same direction through said cores, the winding which produces the controlling flux covering substantially the entire length of said
5 cores.

10 10. Means for amplifying a variable electric current comprising a source of high frequency alternating current, a circuit supplied by said source, two windings included in said circuit, two parallel cores included in

the same magnetic circuit so arranged that they will be magnetized by said windings in opposite directions, and a winding supplied by the variable current so arranged as to produce a flux through the two cores
15 in the same direction and covering substantially the entire length of said cores.

In witness whereof, I have hereunto set my hand this 24th day of November, 1915.

ERNST F. W. ALEXANDERSON.