



US011987183B2

(12) **United States Patent**
Li et al.

(10) **Patent No.:** **US 11,987,183 B2**
(45) **Date of Patent:** ***May 21, 2024**

(54) **PROTECTIVE CASE SYSTEM FOR USE WITH ELECTRONIC DEVICE**

(71) Applicant: **Otter Products, LLC**, Fort Collins, CO (US)

(72) Inventors: **Shanshan Li**, Fort Collins, CO (US); **Joseph A. Prizzi**, Vista, CA (US); **Kevin M. Malak**, San Diego, CA (US); **Jeffrey C. Wicks**, Fort Collins, CO (US); **Andrew J. Walla**, Aurora, CO (US)

(73) Assignee: **Otter Products, LLC**, Fort Collins, CO (US)

(*) Notice: Subject to any disclaimer, the term of this patent is extended or adjusted under 35 U.S.C. 154(b) by 0 days.

This patent is subject to a terminal disclaimer.

(21) Appl. No.: **18/219,830**

(22) Filed: **Jul. 10, 2023**

(65) **Prior Publication Data**

US 2023/0347834 A1 Nov. 2, 2023

Related U.S. Application Data

(63) Continuation of application No. 17/168,258, filed on Feb. 5, 2021, now Pat. No. 11,745,670.

(Continued)

(51) **Int. Cl.**

H04M 1/00 (2006.01)

A45C 11/00 (2006.01)

(Continued)

(52) **U.S. Cl.**

CPC **B60R 11/0241** (2013.01); **A45C 11/00** (2013.01); **F16M 13/02** (2013.01); **H04B 1/3888** (2013.01); **A45C 2011/002** (2013.01)

(58) **Field of Classification Search**

CPC B60R 11/0241; A45C 11/00; F16M 13/02; H04B 1/3888

See application file for complete search history.

(56) **References Cited**

U.S. PATENT DOCUMENTS

3,023,885 A 3/1962 Kindseth
4,029,999 A 6/1977 Neumann et al.
(Continued)

FOREIGN PATENT DOCUMENTS

CN 202488509 U 10/2012
KR 200446444 10/2009

(Continued)

OTHER PUBLICATIONS

outfityours.com (Top 5 Best Clear iPhone 5S and iPhone 5 Cases—Incase, Otterbox, Griffin, Moshi [retrieved from <https://www.youtube.com/watch?v=rWYKJvsDHPw>], YouTube.com [online], May 17, 2013 [retrieved Oct. 11, 2017], 3 pages.

(Continued)

Primary Examiner — Simon King

(57) **ABSTRACT**

A protective case system for use with an electronic device includes a protective case, a handle, and an adapter. The protective case removably receives the electronic device and a display screen of the electronic device remains accessible when the electronic device is installed in the protective case. The handle extends outward from the protective case. The handle is configured for carrying the protective case and the installed electronic device. The adapter is configured to attach to the handle and be bendable by a user to a plurality of positions. The adapter is configured to function as a multi-position stand for the protective case and the installed electronic device. The adapter is further configured to removably affix the protective case and the installed electronic device to a seat.

20 Claims, 15 Drawing Sheets

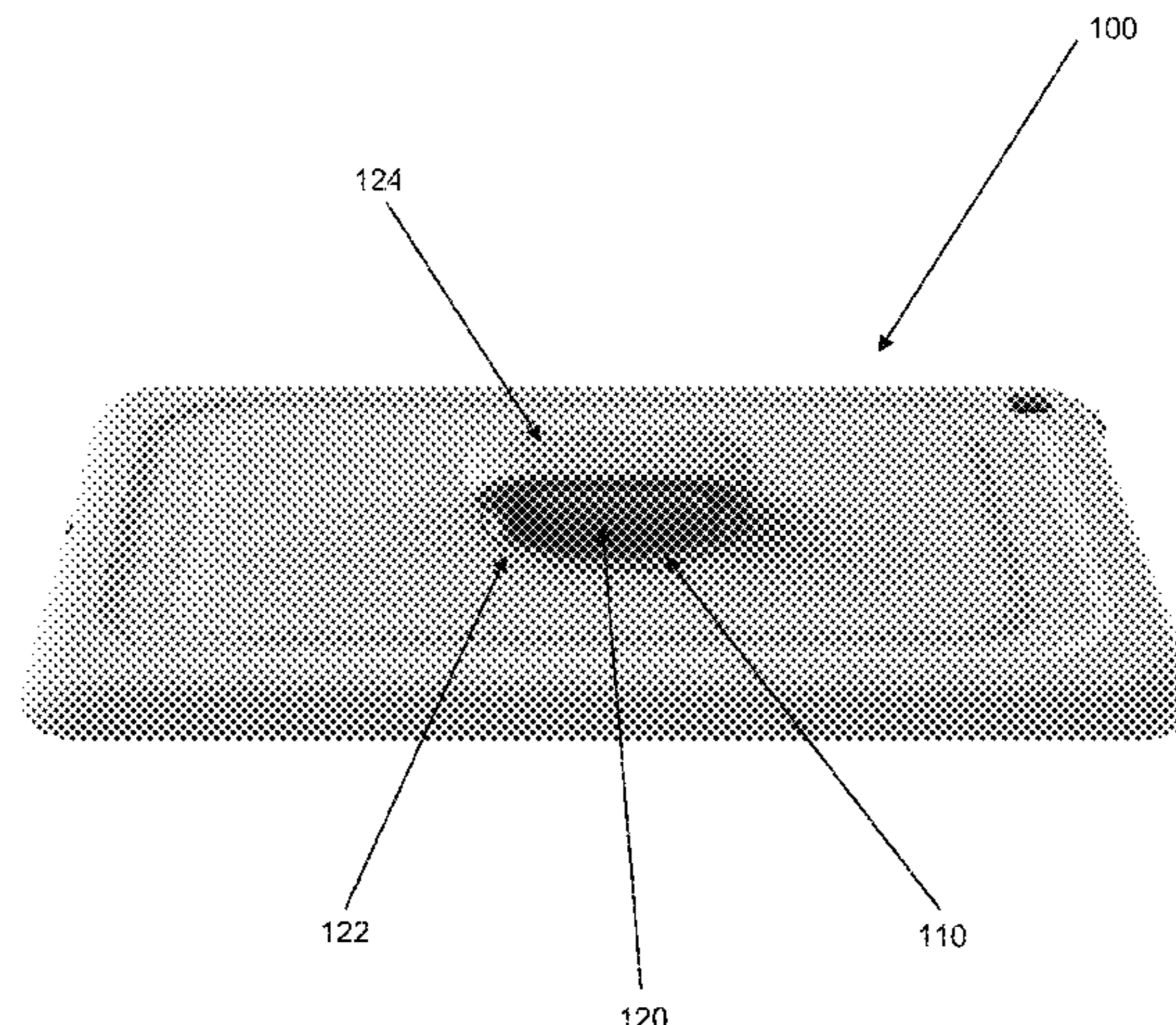

Related U.S. Application Data

(60) Provisional application No. 63/020,619, filed on May 6, 2020.

(51) **Int. Cl.**
B60R 11/02 (2006.01)
F16M 13/02 (2006.01)
H04B 1/3888 (2015.01)

(56) **References Cited**

U.S. PATENT DOCUMENTS

4,097,878	A	6/1978	Cramer	8,442,604	B1	5/2013	Diebel
4,584,718	A	4/1986	Fuller	8,453,344	B2	6/2013	Nishiwaki et al.
4,856,658	A	8/1989	Novak	8,457,701	B2	6/2013	Diebel
4,925,146	A	5/1990	Hegarty	8,490,783	B1	7/2013	Fan
4,933,988	A	6/1990	Thibault	8,509,865	B1	8/2013	LaColla et al.
4,981,243	A	1/1991	Rogowski	8,560,031	B2	10/2013	Barnett et al.
5,025,921	A	6/1991	Gasparaitis et al.	8,567,599	B2	10/2013	Beatty et al.
5,123,044	A	6/1992	Tate	8,599,547	B2	12/2013	Richardson et al.
5,138,523	A	8/1992	Benck et al.	8,613,349	B1	12/2013	Halko et al.
5,360,108	A	11/1994	Alagia	8,676,281	B1	3/2014	Caulder et al.
5,368,159	A	11/1994	Doria	8,755,852	B2	6/2014	Hynecek et al.
5,380,968	A	1/1995	Morse	8,777,002	B2	7/2014	Thomas et al.
5,383,091	A	1/1995	Snell	8,798,675	B2	8/2014	Salmon et al.
5,386,084	A	1/1995	Risko	8,800,762	B2	8/2014	Fathollahi
5,388,691	A	2/1995	White	8,950,725	B2	2/2015	Huang et al.
5,388,692	A	2/1995	Withrow et al.	8,965,458	B2	2/2015	Richardson et al.
D365,927	S	1/1996	Cho	9,008,738	B1	4/2015	Dong
5,508,479	A	4/1996	Schooley	9,060,580	B2	6/2015	Tages
5,541,813	A	7/1996	Satoh et al.	9,086,842	B2	7/2015	Wen et al.
5,671,120	A	9/1997	Kikinisi	9,089,056	B2	7/2015	Rayner
5,808,865	A	9/1998	Alves	9,098,238	B2	8/2015	Richardson et al.
6,097,593	A	8/2000	Faranda et al.	9,125,297	B2	9/2015	Magness
6,115,248	A	9/2000	Canova et al.	9,136,897	B2	9/2015	Hynecek et al.
6,151,206	A	11/2000	Kato et al.	9,153,112	B1	10/2015	Kiani et al.
6,283,299	B1	9/2001	Lee	9,226,057	B1	12/2015	Davis et al.
6,311,017	B1	10/2001	Mori	9,266,664	B2	2/2016	Bau
6,317,313	B1	11/2001	Mosgrove et al.	9,274,556	B2	3/2016	Gallouzi et al.
6,349,824	B1	2/2002	Yamada	9,295,174	B2	3/2016	Witter et al.
6,375,009	B1	4/2002	Lee	9,316,026	B2	4/2016	Myers et al.
6,445,577	B1	9/2002	Madsen et al.	9,367,090	B2	6/2016	Barnett et al.
6,456,487	B1	9/2002	Hetterick	9,377,154	B2	6/2016	Hung et al.
6,490,155	B2	12/2002	Han et al.	D762,258	S	7/2016	Jenkins
6,545,862	B1	4/2003	Gettemy et al.	9,408,448	B2	8/2016	Kay et al.
6,616,111	B1	9/2003	White	D766,226	S	9/2016	Wu
6,625,394	B2	9/2003	Smith et al.	D766,227	S	9/2016	Wu
6,626,362	B1	9/2003	Steiner et al.	D769,855	S	10/2016	Deng
6,701,159	B1	3/2004	Powell	9,462,099	B2	10/2016	Wilson et al.
6,762,935	B2	7/2004	Hidewasa	9,481,490	B2	11/2016	Venida et al.
6,865,076	B2	3/2005	Lunsford	9,487,376	B2	11/2016	Salentine et al.
6,966,519	B2	11/2005	Salentine et al.	9,501,101	B2	11/2016	Daley, III
7,050,841	B1	5/2006	Onda	9,503,147	B2	11/2016	Witter et al.
7,072,699	B2	7/2006	Eiden	9,537,526	B2	1/2017	Wilson et al.
D526,780	S	8/2006	Richardson et al.	9,540,856	B2	1/2017	Lin
7,145,767	B2	12/2006	Mache et al.	9,545,140	B1	1/2017	Johnson et al.
7,194,291	B2	3/2007	Peng	9,615,476	B2	4/2017	Rayner et al.
D542,524	S	5/2007	Richardson et al.	9,622,556	B2	4/2017	Fathollahi et al.
7,236,588	B2	6/2007	Gartrell	9,654,605	B2	5/2017	Goldfain et al.
7,343,184	B2	3/2008	Rostami	9,660,684	B2	5/2017	Rayner
7,359,184	B2	4/2008	Lord	9,687,076	B2	6/2017	Su
D574,819	S	8/2008	Andre et al.	9,743,540	B2	8/2017	Magness
D581,155	S	11/2008	Richardson et al.	9,774,713	B2	9/2017	Guerdrum et al.
D581,421	S	11/2008	Richardson et al.	9,788,620	B1	10/2017	Parkinson
D587,008	S	2/2009	Richardson et al.	9,807,211	B2	10/2017	Guerdrum et al.
D589,016	S	3/2009	Richardson et al.	9,851,758	B2	12/2017	Rowley
7,555,325	B2	6/2009	Goros	D808,376	S	1/2018	Kim
7,558,594	B2	7/2009	Wilson	D808,377	S	1/2018	Witter et al.
7,688,580	B2	3/2010	Richardson et al.	9,854,897	B1	1/2018	Pelkey, Jr. et al.
7,845,608	B1	12/2010	Chen et al.	9,871,550	B2	1/2018	Witter et al.
7,889,489	B2	2/2011	Richardson et al.	9,946,301	B2	4/2018	Lan et al.
7,907,394	B2	3/2011	Richardson et al.	D824,376	S	7/2018	Lee
7,933,122	B2	4/2011	Richardson et al.	10,027,783	B2	7/2018	Dukerschein et al.
8,049,727	B2	11/2011	Hanson et al.	10,058,155	B2	8/2018	Guerdrum et al.
8,204,561	B2	6/2012	Mongan et al.	D827,627	S	9/2018	Lee
8,226,054	B2	7/2012	Chen et al.	D829,700	S	10/2018	Kim
				10,103,769	B2	10/2018	Witter et al.
				10,136,716	B2	11/2018	Northrup et al.
				10,178,903	B2	1/2019	Guerdrum et al.
				10,206,472	B1	2/2019	Northrup et al.
				10,216,223	B2	2/2019	Hsu et al.
				10,485,312	B2	11/2019	Rodriguez
				11,068,030	B2	7/2021	Marcks, Jr. et al.
				11,350,716	B2*	6/2022	Beeler A45C 11/00
				11,392,171	B2*	7/2022	Del Moral A45C 13/002
				2001/0054594	A1	12/2001	Maier-Hunke
				2002/0065054	A1	5/2002	Humphreys et al.
				2002/0079244	A1	6/2002	Kwong
				2004/0134812	A1	7/2004	Yeh
				2004/0150945	A1	8/2004	Mache et al.
				2005/0088811	A1	4/2005	Ulla et al.

(56)

References Cited

U.S. PATENT DOCUMENTS

2005/0213298 A1	9/2005	Doherty et al.	2014/0080553 A1	3/2014	Torset et al.	
2005/0224508 A1	10/2005	Tajiri et al.	2014/0097102 A1	4/2014	Piatt et al.	
2005/0279661 A1	12/2005	Hodges	2014/0099526 A1	4/2014	Powell et al.	
2006/0027718 A1	2/2006	Quijano et al.	2014/0128132 A1	5/2014	Cox	
2006/0066438 A1	3/2006	Altounian et al.	2014/0141838 A1	5/2014	Cai et al.	
2006/0172765 A1	8/2006	Lev	2014/0152890 A1	6/2014	Rayner	
2006/0237495 A1	10/2006	Chen et al.	2014/0165366 A1*	6/2014	Hochman	H04M 1/04 248/176.1
2006/0243679 A1	11/2006	Dickerson	2014/0166707 A1	6/2014	Leisey-Bartsch	
2006/0255493 A1	11/2006	Fouladpour	2014/0168884 A1	6/2014	Wylie	
2007/0071423 A1	3/2007	Fantone et al.	2014/0183064 A1	7/2014	Ge	
2007/0115387 A1	5/2007	Ho	2014/0183065 A1	7/2014	Toulotte	
2007/0146985 A1	6/2007	Mick et al.	2014/0187289 A1	7/2014	Cataldo et al.	
2007/0158220 A1	7/2007	Cleereman et al.	2014/0200056 A1	7/2014	Liu	
2007/0297149 A1	12/2007	Richardson et al.	2014/0202885 A1*	7/2014	Bell	A45C 11/00 206/37
2008/0117578 A1	5/2008	Moscovitch	2014/0227026 A1	8/2014	O'Neill et al.	
2008/0163463 A1	7/2008	Hulden	2014/0228074 A1	8/2014	Kulkarni et al.	
2008/0304692 A1	12/2008	Zhang	2014/0262848 A1	9/2014	Fathollahi et al.	
2009/0001232 A1	1/2009	Seo et al.	2014/0262934 A1	9/2014	Fathollahi et al.	
2009/0034169 A1	2/2009	Richardson et al.	2014/0265765 A1	9/2014	Khodapanah et al.	
2009/0079665 A1	3/2009	Moscovitch	2014/0265767 A1	9/2014	Fathollahi	
2009/0161903 A1	6/2009	White	2014/0299488 A1	10/2014	Andrew	
2009/0237377 A1	9/2009	Lai et al.	2014/0302896 A1	10/2014	Xu et al.	
2009/0283184 A1	11/2009	Han	2014/0332418 A1	11/2014	Cheung et al.	
2010/0006468 A1	1/2010	Lin	2015/0061477 A1	3/2015	Wilson	
2010/0090085 A1	4/2010	Corrion	2015/0062787 A1	3/2015	Wilson et al.	
2010/0093412 A1	4/2010	Serra et al.	2015/0068935 A1	3/2015	Kay et al.	
2010/0122756 A1	5/2010	Longinotti-Buitoni	2015/0083615 A1	3/2015	Lay et al.	
2010/0141864 A1	6/2010	Lai	2015/0111623 A1	4/2015	Hegemier et al.	
2010/0147737 A1	6/2010	Richardson et al.	2015/0111626 A1*	4/2015	Bell	G06F 1/1637 455/575.8
2010/0195279 A1	8/2010	Michael	2015/0133183 A1	5/2015	Alameh et al.	
2010/0203931 A1	8/2010	Hynecek et al.	2015/0141090 A1	5/2015	Hwan et al.	
2010/0215188 A1	8/2010	Wilcox	2015/0141095 A1	5/2015	Kim	
2010/0230301 A1	9/2010	Fellig	2015/0172431 A1	6/2015	Huang	
2011/0064401 A1	3/2011	DeSorbo	2015/0189160 A1	7/2015	Auger et al.	
2011/0075349 A1	3/2011	Ma et al.	2015/0194997 A1	7/2015	Johnson et al.	
2011/0170256 A1	7/2011	Lee	2015/0194998 A1	7/2015	Fathollahi	
2011/0192857 A1	8/2011	Rothbaum et al.	2015/0195938 A1	7/2015	Witter et al.	
2011/0216495 A1	9/2011	Marx	2015/0201723 A1	7/2015	Rayner et al.	
2011/0228459 A1	9/2011	Richardson et al.	2015/0214989 A1	7/2015	Yeh et al.	
2011/0235846 A1	9/2011	Jiang et al.	2015/0220766 A1	8/2015	Russell et al.	
2011/0294556 A1	12/2011	Carlberg et al.	2015/0257285 A1	9/2015	Wilson et al.	
2012/0018325 A1	1/2012	Kim	2015/0257287 A1	9/2015	Tages	
2012/0031788 A1	2/2012	Mongan et al.	2015/0301560 A1*	10/2015	Garland, Sr.	G03B 17/561 455/575.8
2012/0037524 A1	2/2012	Thomas et al.	2015/0304466 A1	10/2015	Tamatsu	
2012/0037536 A1	2/2012	Thomas et al.	2016/0007705 A1	1/2016	Liebers et al.	
2012/0106069 A1	5/2012	Strauser	2016/0036478 A1	2/2016	Wong	
2012/0111881 A1	5/2012	Gaddis et al.	2016/0072933 A1	3/2016	Cox	
2012/0170194 A1	7/2012	Lord et al.	2016/0080024 A1	3/2016	Wilson et al.	
2012/0287565 A1	11/2012	Bennett	2016/0088750 A1	3/2016	Wu	
2012/0308164 A1	12/2012	Hudson	2016/0090767 A1	3/2016	Park et al.	
2012/0325607 A1	12/2012	Webster et al.	2016/0113368 A1	4/2016	Tu et al.	
2013/0027862 A1	1/2013	Rayner	2016/0122821 A1	5/2016	Liu et al.	
2013/0039521 A1	2/2013	Zhou et al.	2016/0142093 A1	5/2016	Phang	
2013/0083953 A1	4/2013	Chang	2016/0164565 A1	6/2016	Witter et al.	
2013/0088813 A1	4/2013	Su et al.	2016/0173670 A1	6/2016	Langhein	
2013/0098788 A1	4/2013	McCarville et al.	2016/0179143 A1	6/2016	Bidwell et al.	
2013/0107449 A1	5/2013	Su et al.	2016/0183392 A1	6/2016	Kelley	
2013/0109253 A1	5/2013	Gammon et al.	2016/0195898 A1	7/2016	Lau	
2013/0117487 A1	5/2013	Leung	2016/0198822 A1	7/2016	Lee et al.	
2013/0126533 A1	5/2013	Klosky	2016/0254836 A1	9/2016	Alsberg et al.	
2013/0175186 A1	7/2013	Simmer	2016/0261133 A1	9/2016	Wang	
2013/0177181 A1	7/2013	Marcus	2016/0282905 A1	9/2016	Laine et al.	
2013/0181492 A1*	7/2013	Prescott	2016/0286920 A1	10/2016	Lean et al.	
		B60R 7/088 297/217.1	2016/0286921 A1	10/2016	Northrup et al.	
2013/0220841 A1	8/2013	Yang	2016/0295981 A1	10/2016	Lay et al.	
2013/0220847 A1	8/2013	Fisher et al.	2017/0026498 A1	1/2017	Goldfain et al.	
2013/0222989 A1	8/2013	Chen	2017/0041037 A1	2/2017	Witter et al.	
2013/0230202 A1	9/2013	Widner et al.	2017/0099922 A1	4/2017	Guerdrum et al.	
2013/0240578 A1	9/2013	Yu	2017/0099924 A1	4/2017	Fathollahi et al.	
2013/0262248 A1	10/2013	Kim et al.	2017/0119120 A1	5/2017	Richardson et al.	
2013/0292269 A1	11/2013	Tages	2017/0237460 A1	8/2017	Rayner	
2013/0292288 A1	11/2013	Willes	2017/0279478 A1	9/2017	Fathollahi	
2014/0003647 A1	1/2014	Liu	2017/0327054 A1	11/2017	Yu et al.	
2014/0049142 A1	2/2014	Magness	2017/0328517 A1	11/2017	Wessels	
2014/0065847 A1	3/2014	Salmon et al.	2017/0353208 A1	12/2017	Wilson et al.	

(56)

References Cited

U.S. PATENT DOCUMENTS

2017/0359096 A1 12/2017 Witter et al.
2017/0360200 A1 12/2017 Cohen
2018/0136695 A1 5/2018 Lo et al.
2018/0167498 A1 6/2018 Drakos
2018/0271242 A1* 9/2018 Cavaretta, III A45C 13/02
2018/0369599 A1 12/2018 Smith
2019/0094853 A1 3/2019 Overall
2019/0141848 A1 5/2019 Sung
2019/0212774 A1 7/2019 Patterson et al.
2019/0222682 A1 7/2019 Ren et al.
2019/0250664 A1 8/2019 Eslava et al.
2019/0281147 A1 9/2019 Sherburne et al.
2019/0286191 A1 9/2019 Correll, Jr.
2020/0200322 A1 6/2020 Marcks, Jr. et al.
2020/0326749 A1* 10/2020 Del Moral A45C 11/00

FOREIGN PATENT DOCUMENTS

KR 101394285 5/2014
WO 1994000037 A1 1/1994
WO 1999041958 A1 8/1999
WO 2015103599 A1 7/2015

OTHER PUBLICATIONS

Randomrazr (New Otterbox Symmetry Case—The Slim Protective Case for the iPhone 5S/5C [retrieved from <https://www.youtube.com/watch?v=zGWZTGamuT0>], YouTube.com [online], Mar. 30, 2014 [retrieved Oct. 11, 2017]), 5 pages.

* cited by examiner

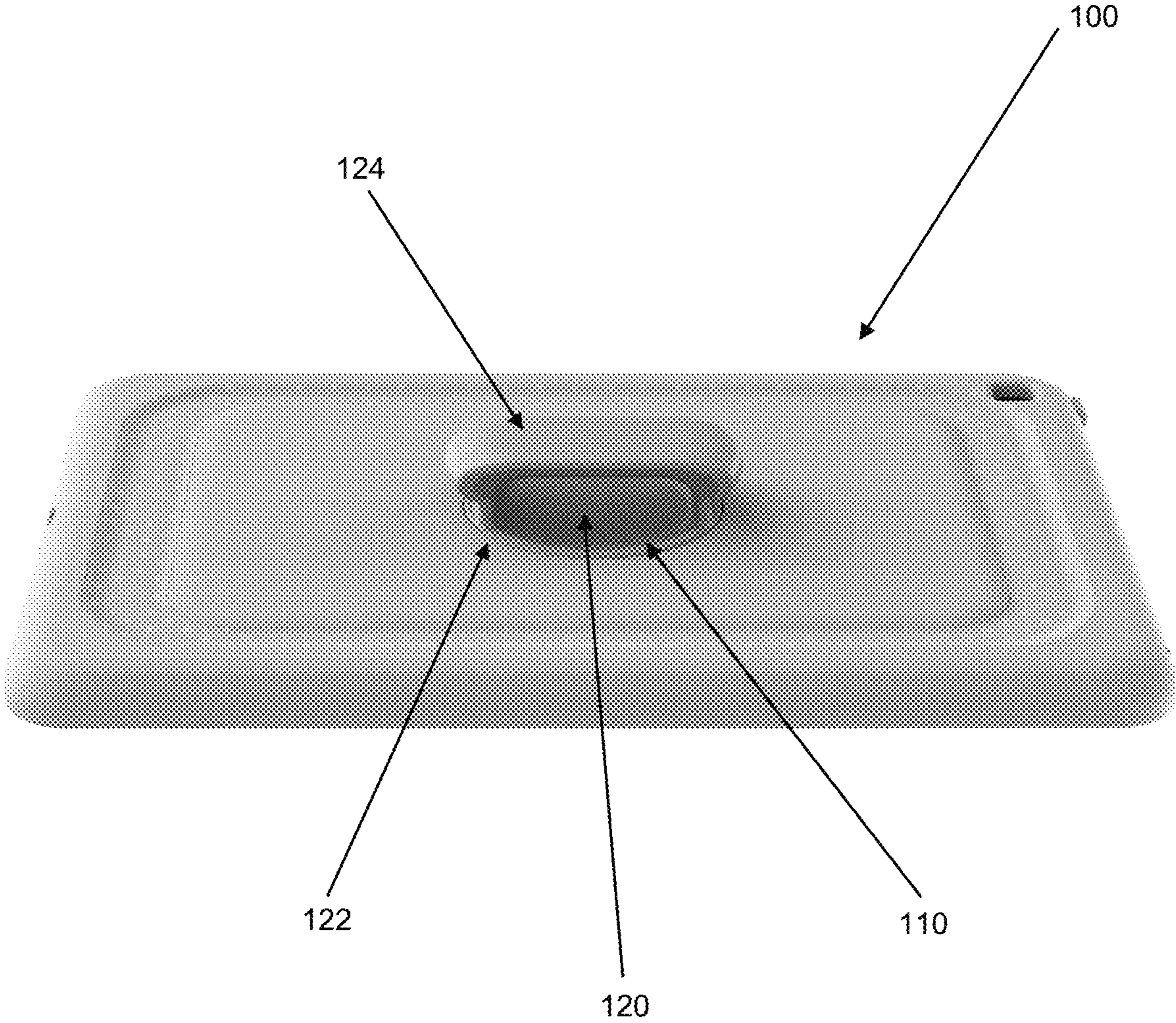

Figure 1

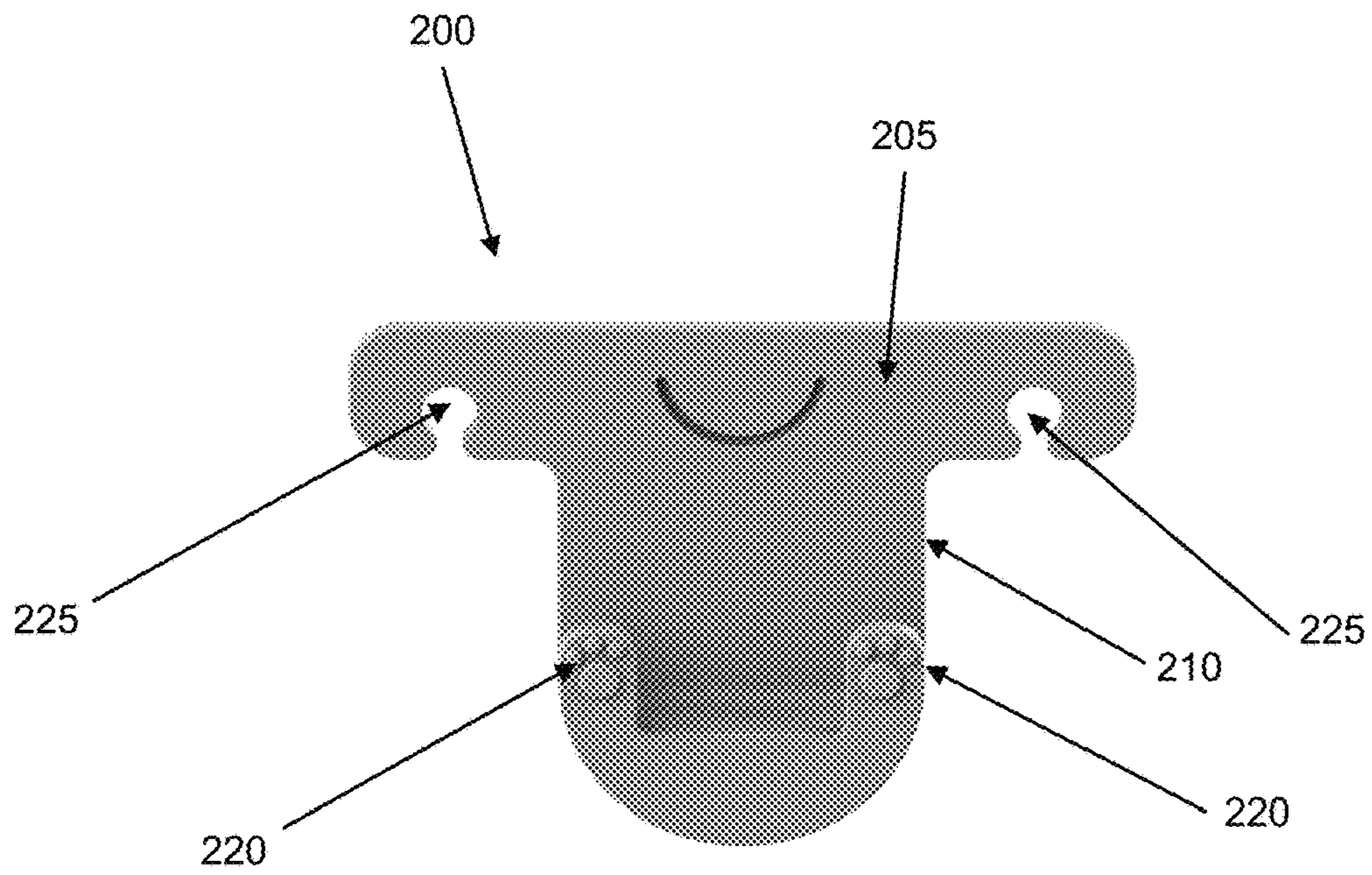

Figure 2A

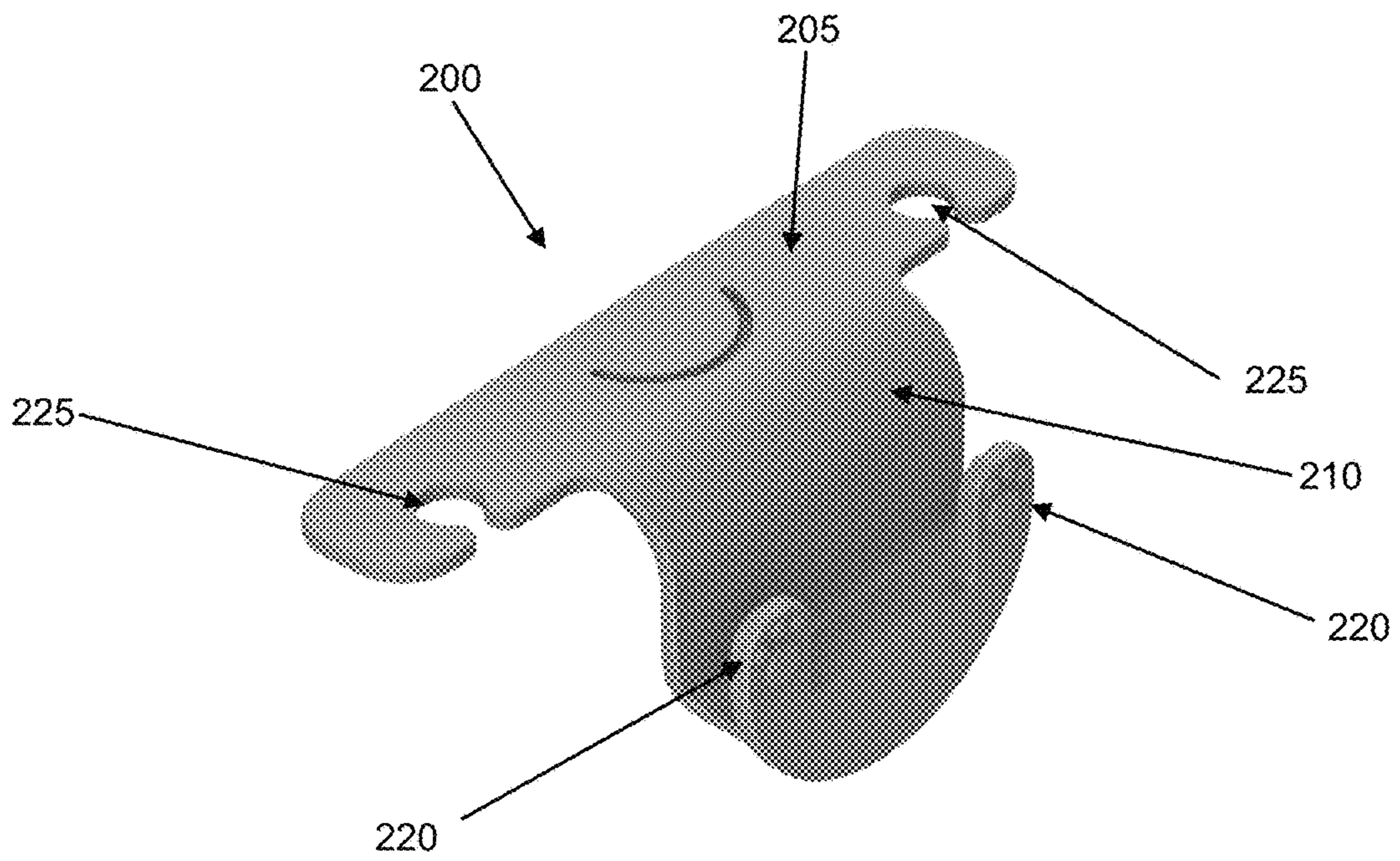

Figure 2B

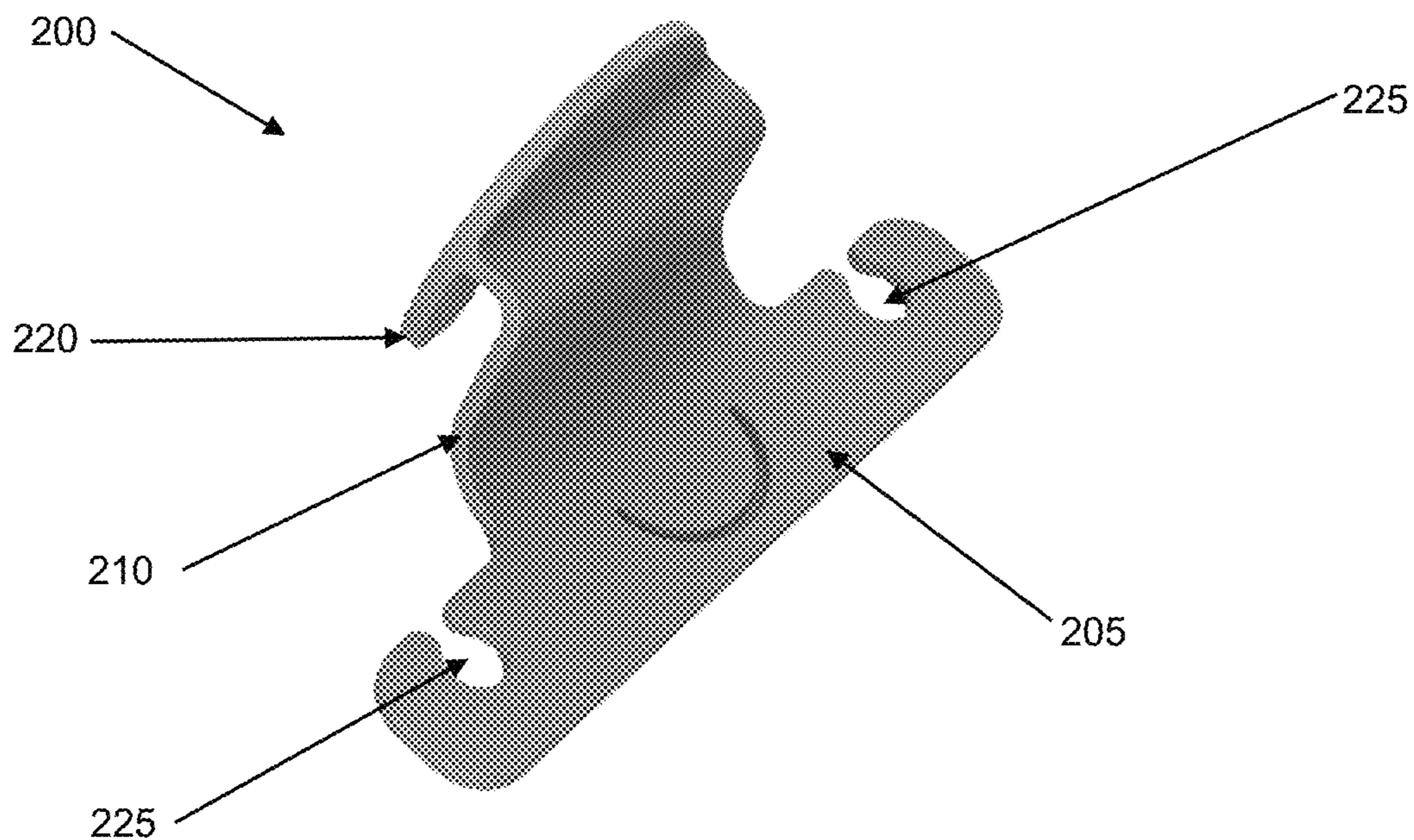

Figure 2C

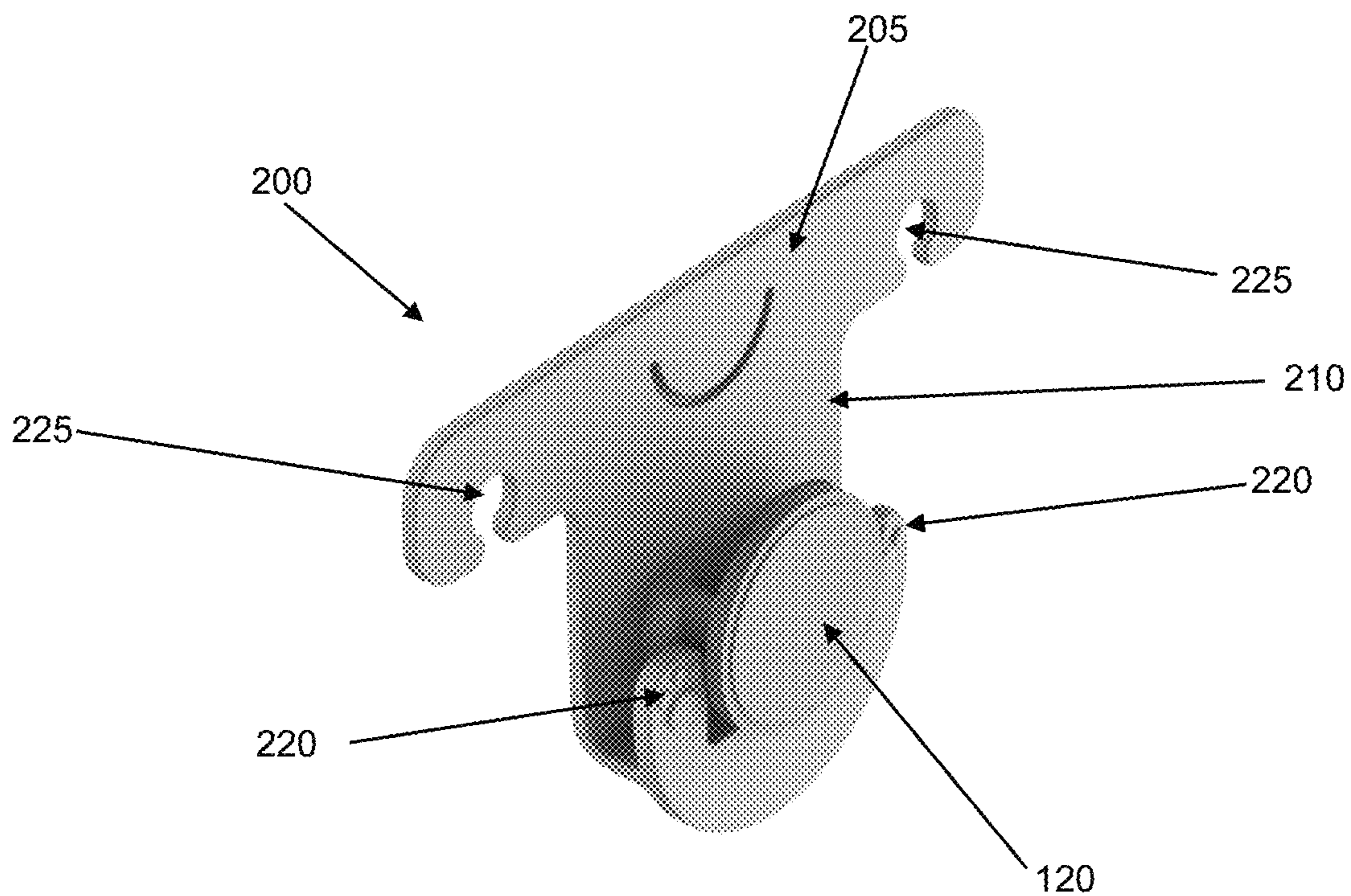

Figure 2D

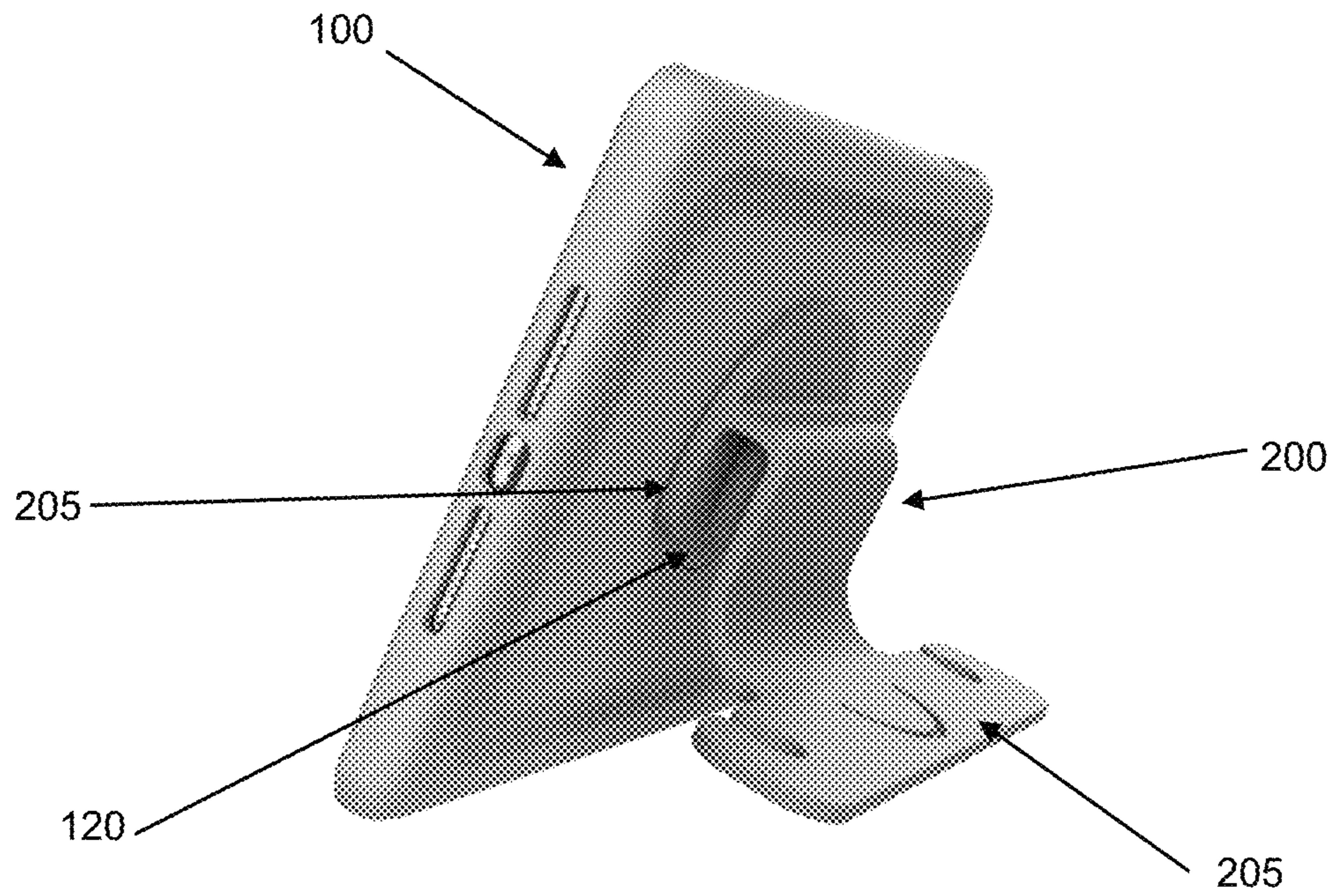

Figure 3A

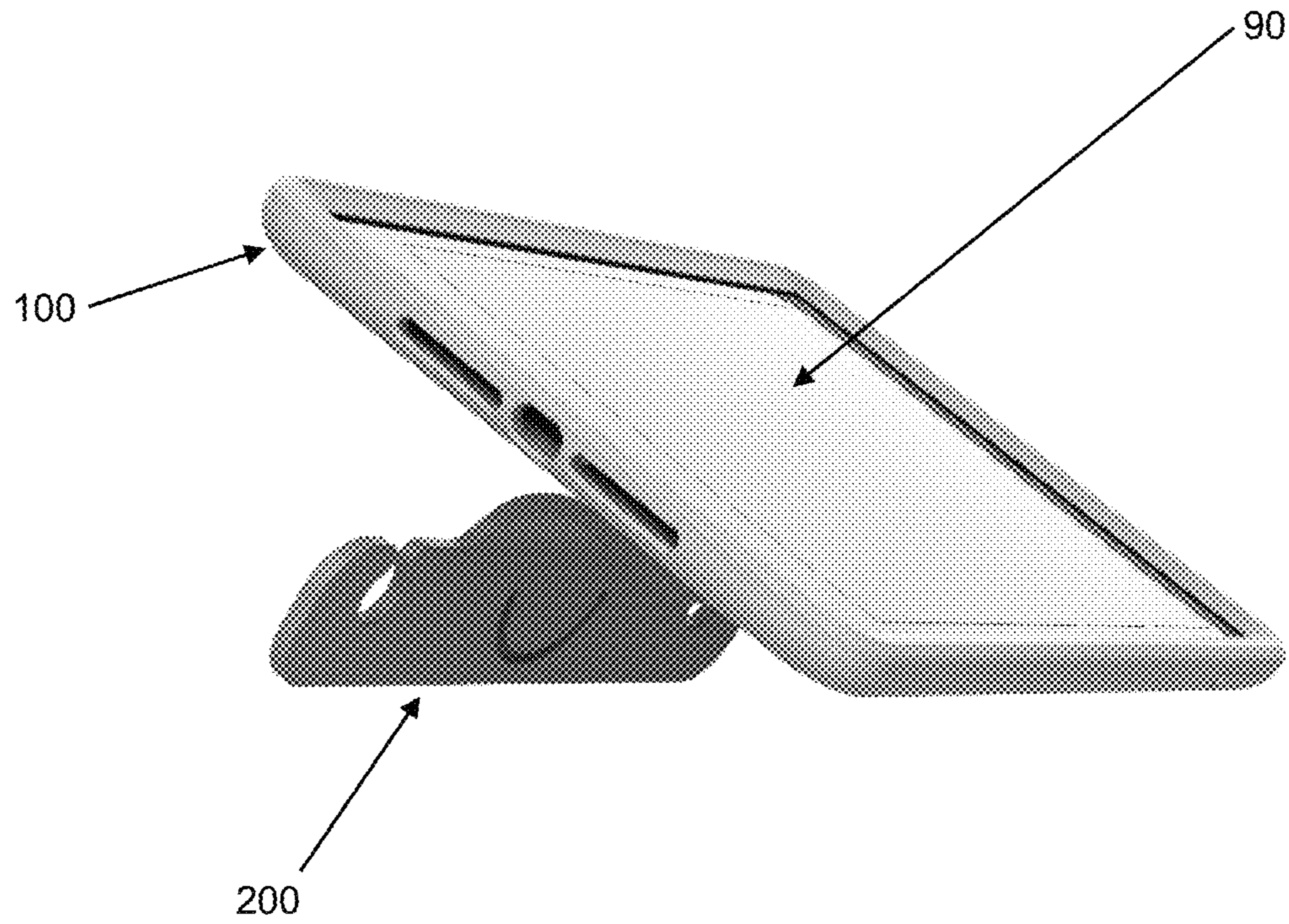

Figure 3B

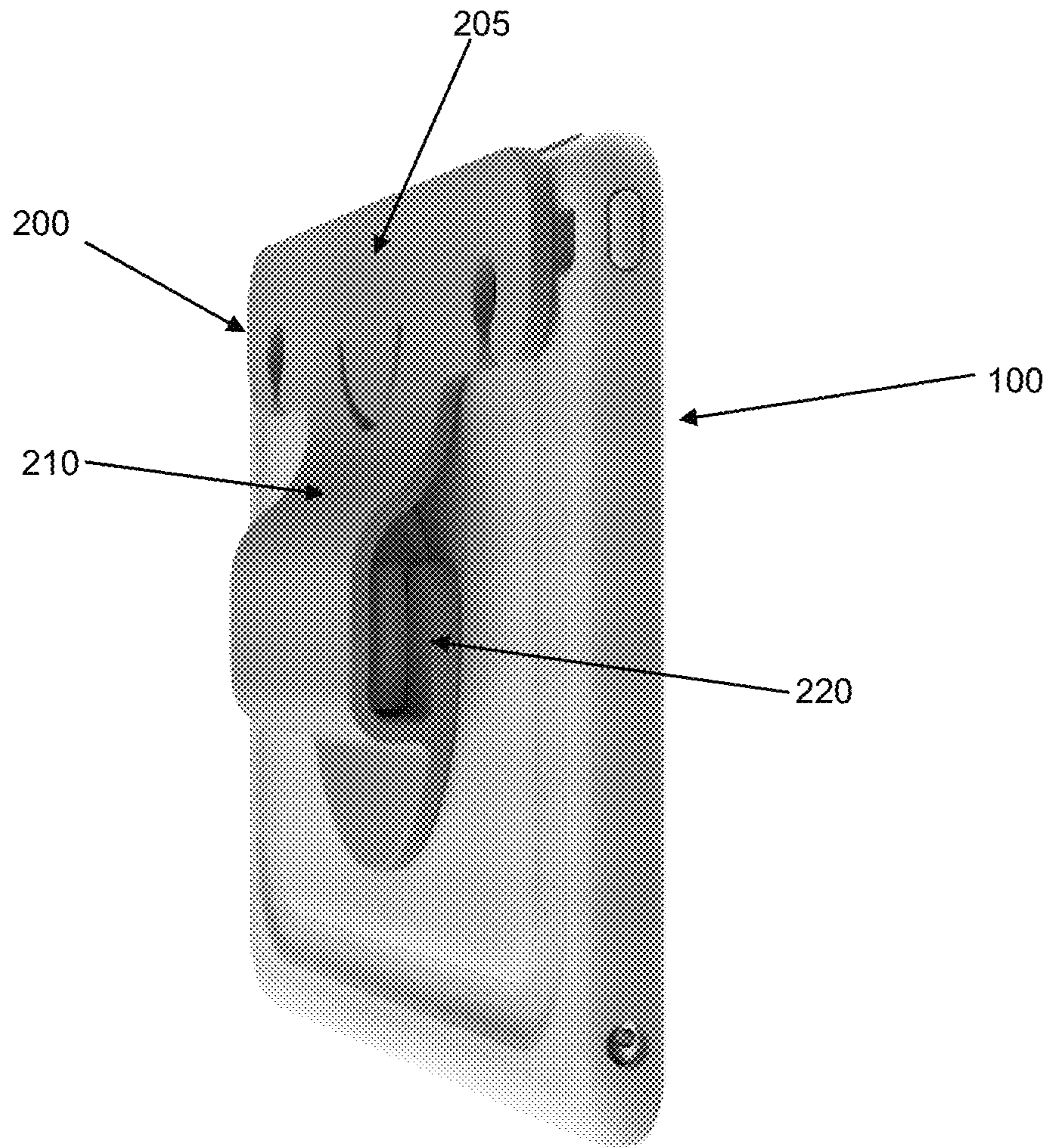

Figure 3C

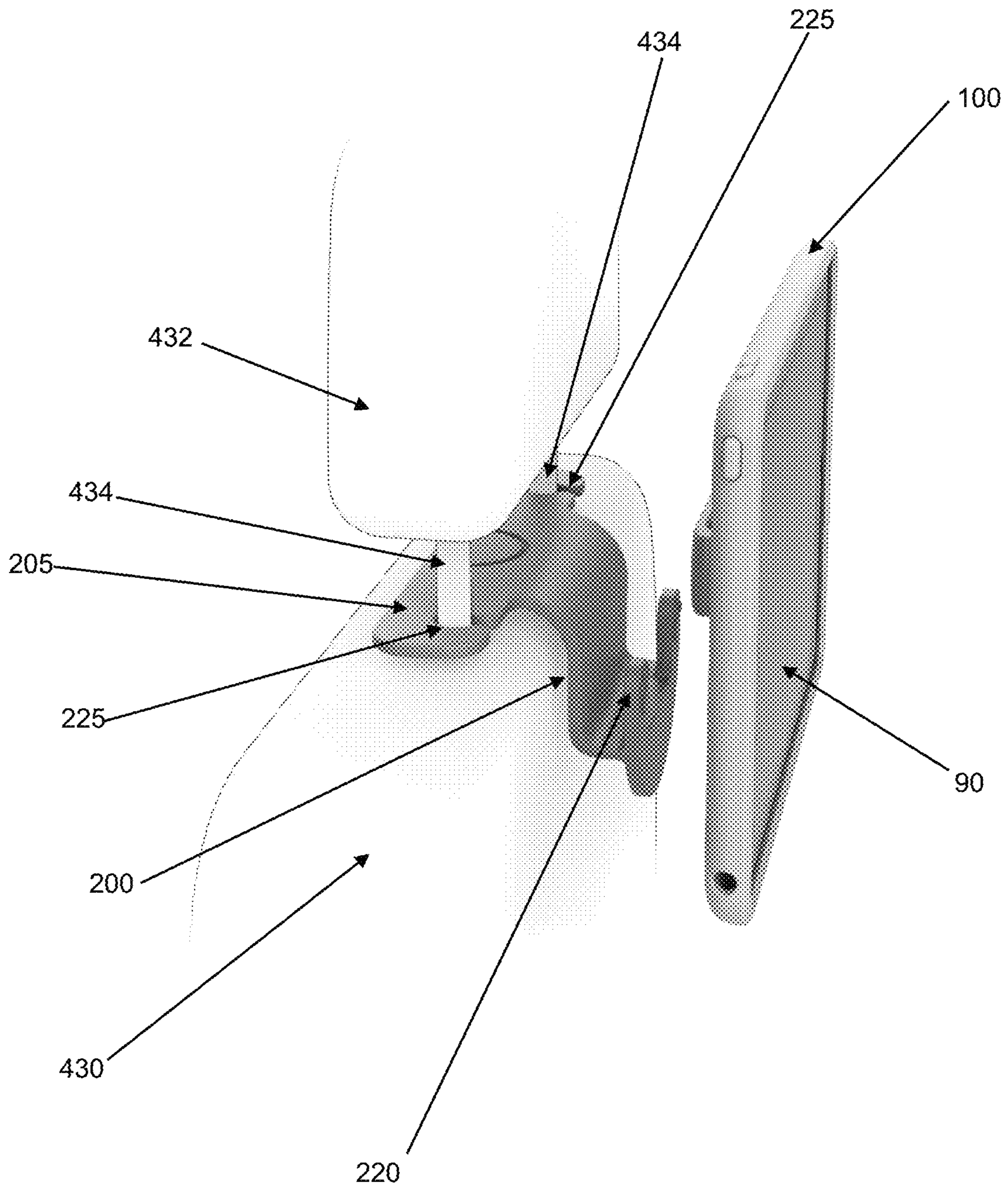

Figure 4

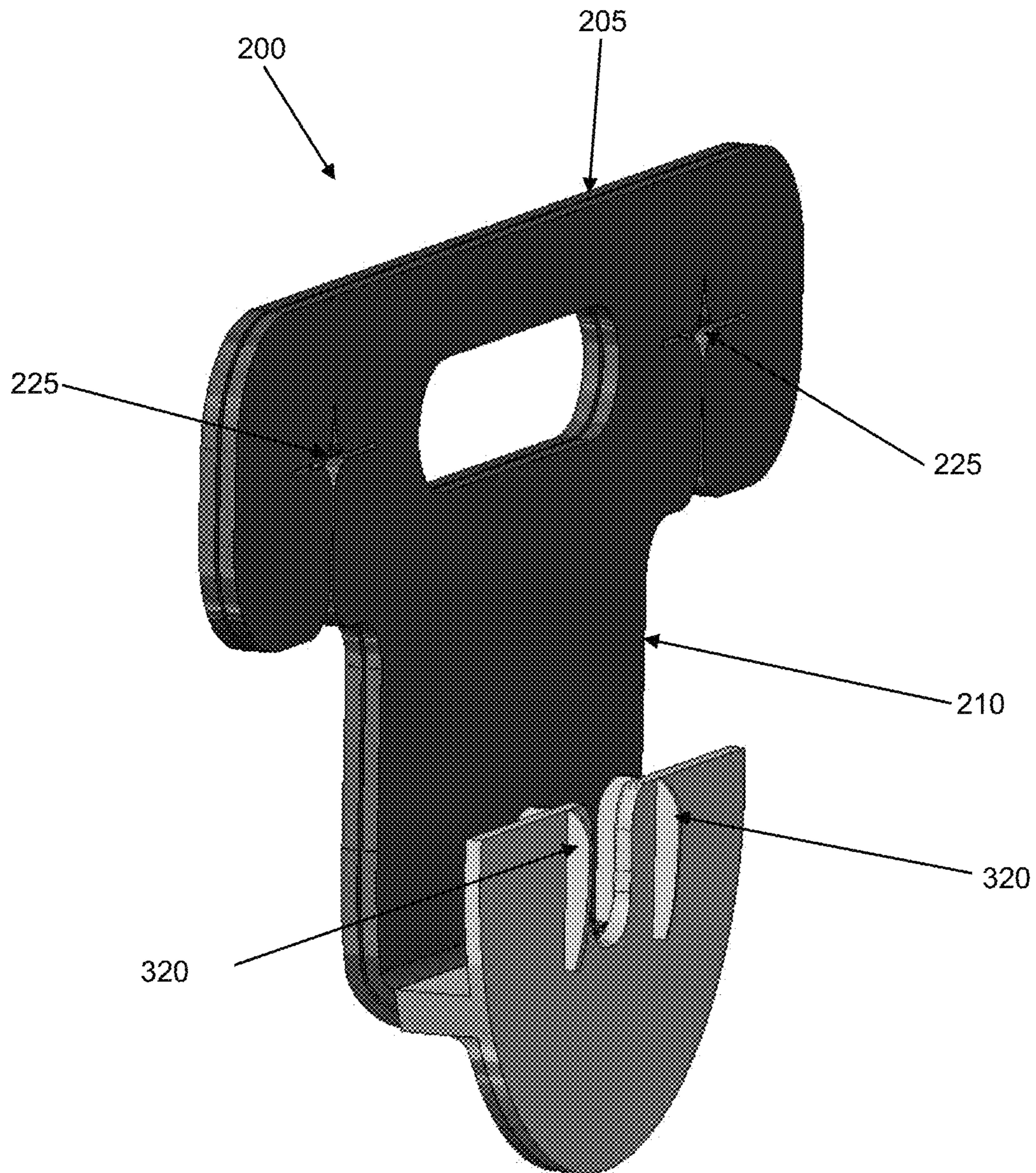

Figure 5

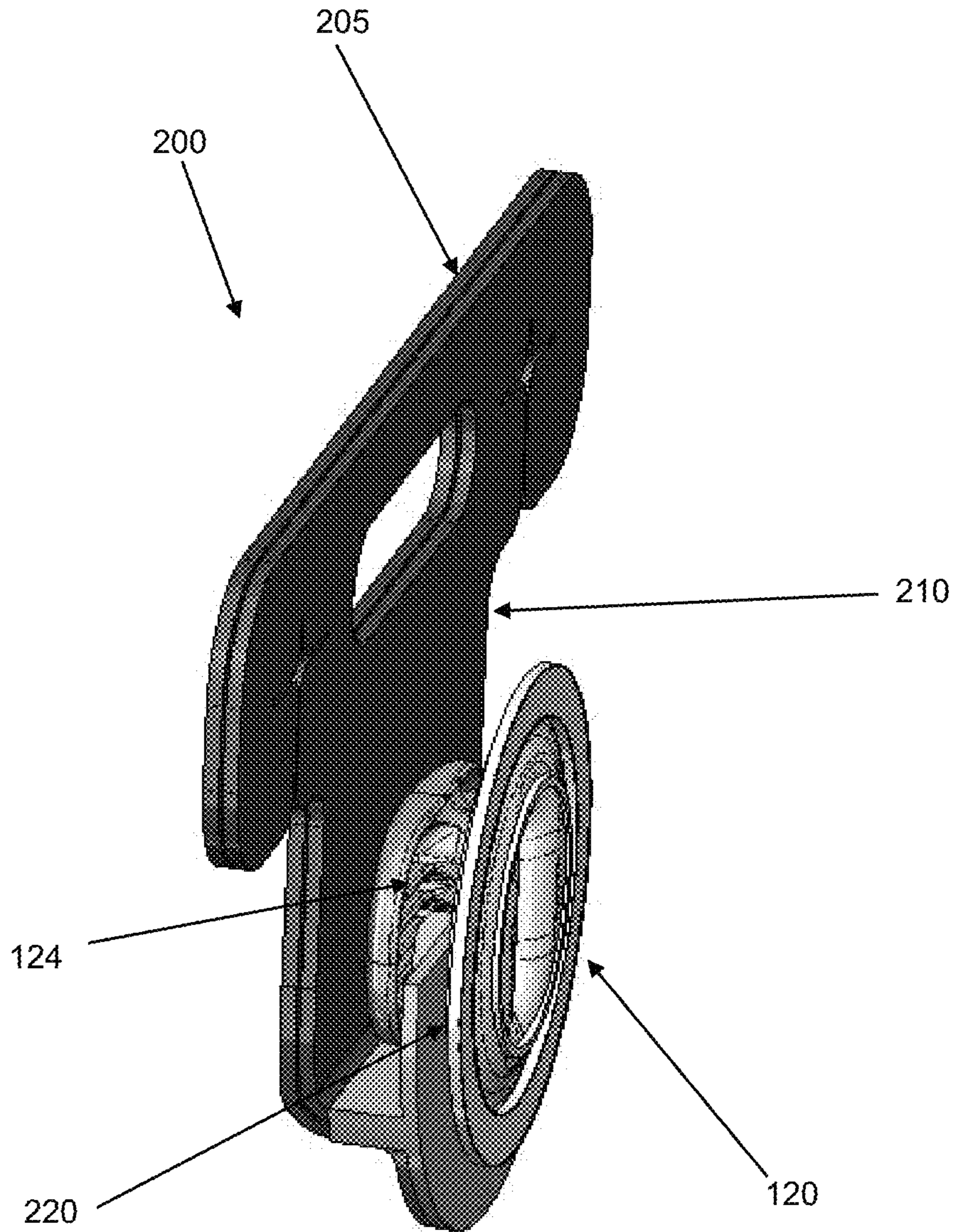

Figure 6

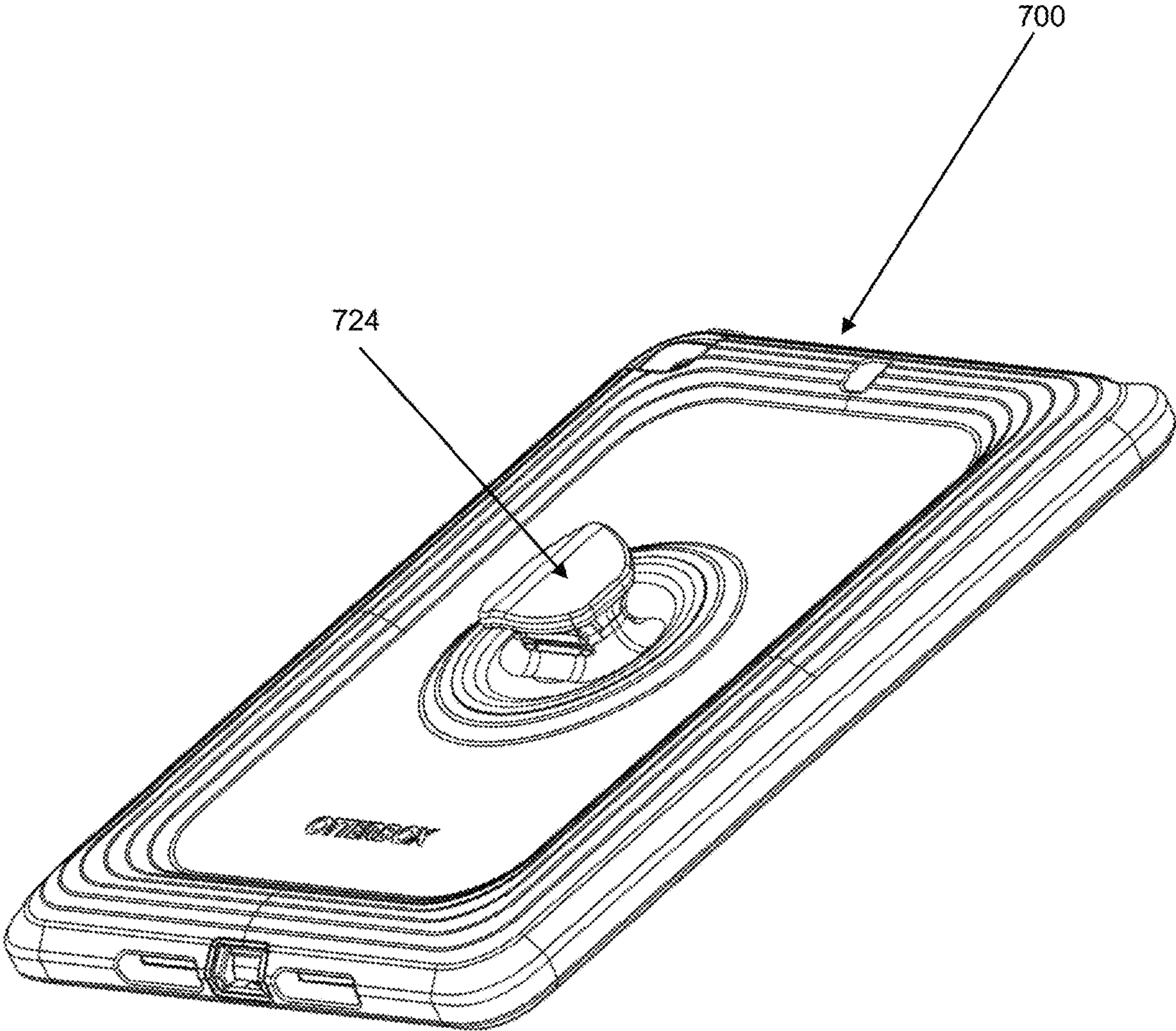

Figure 7

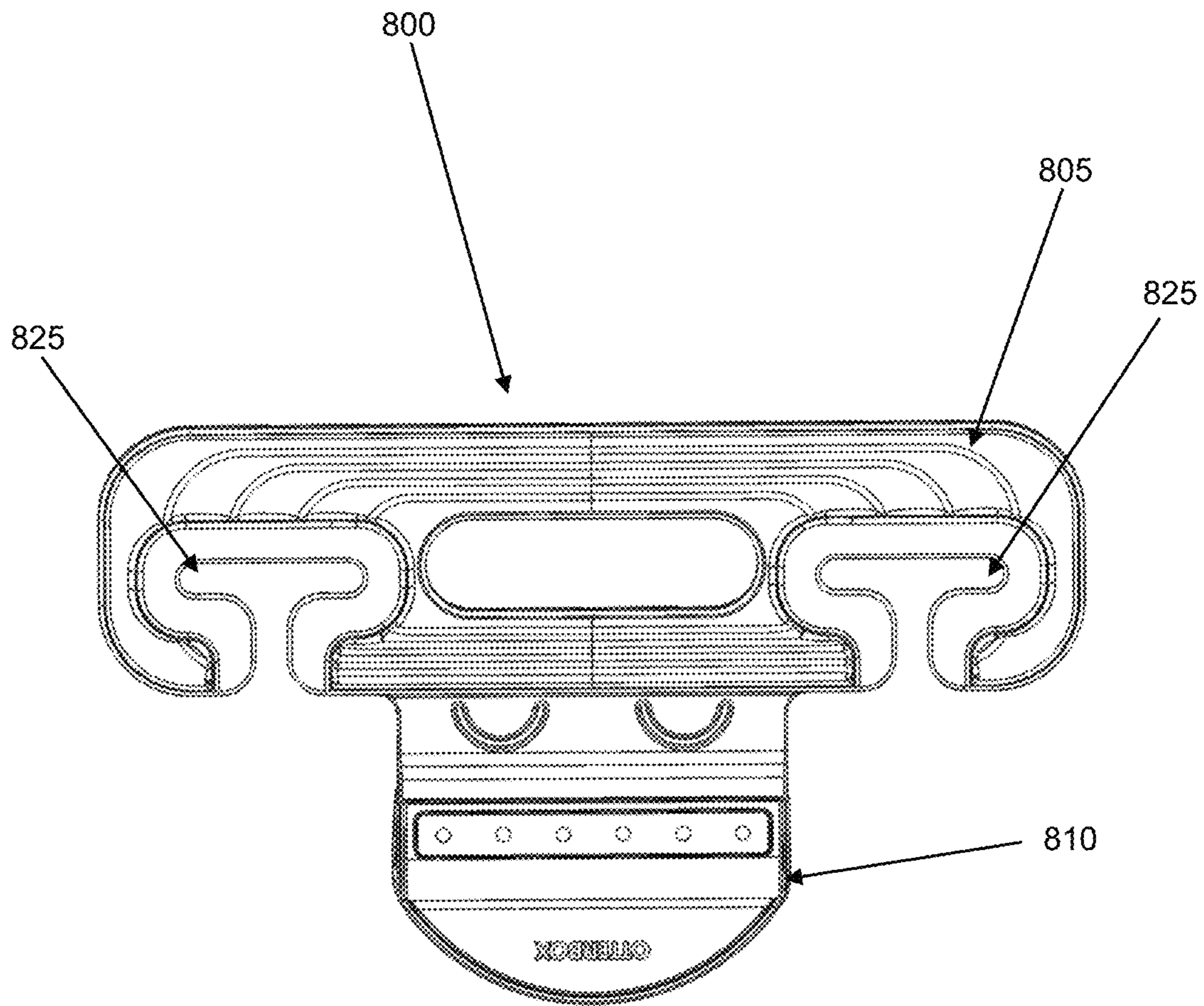

Figure 8

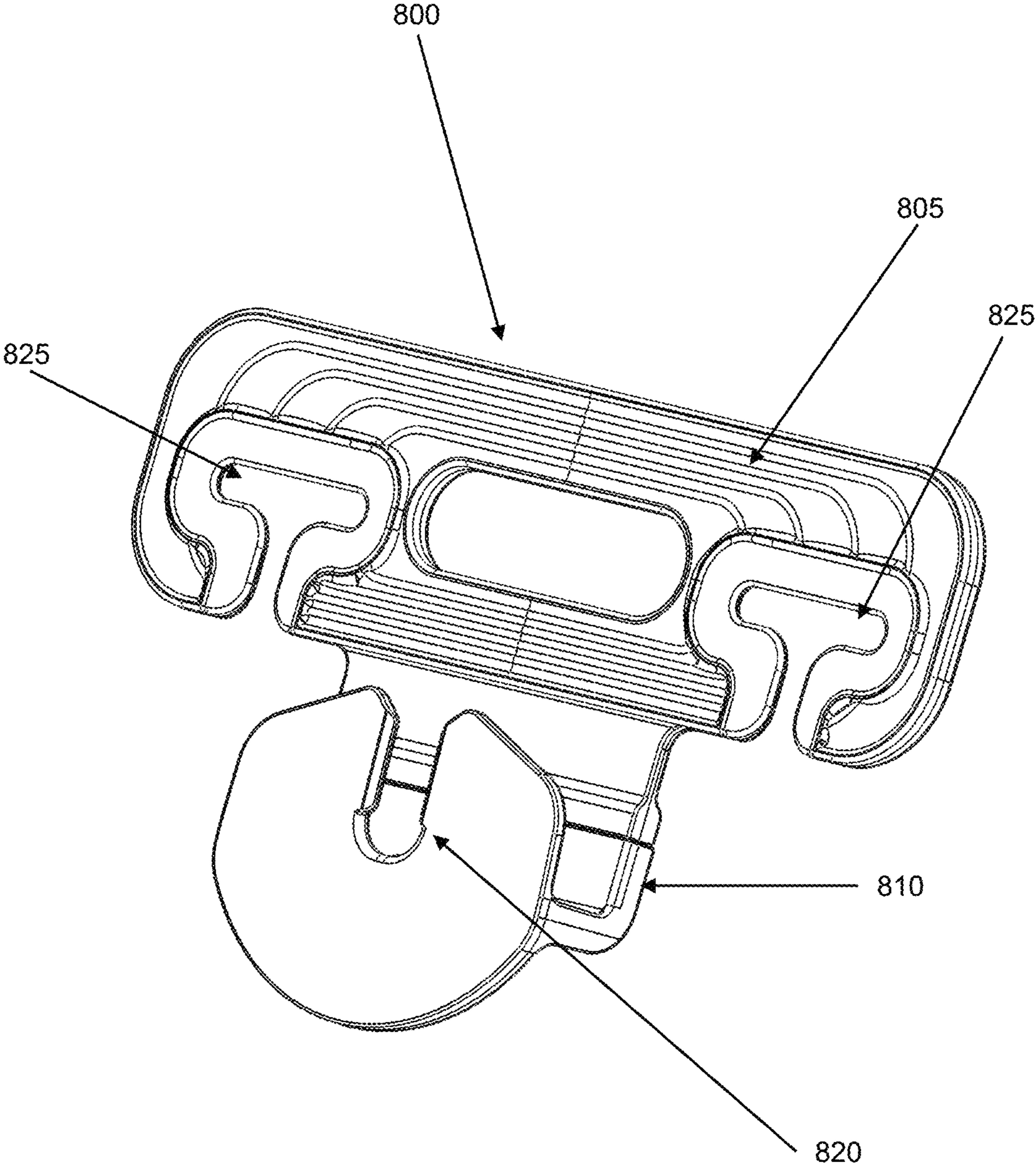

Figure 9

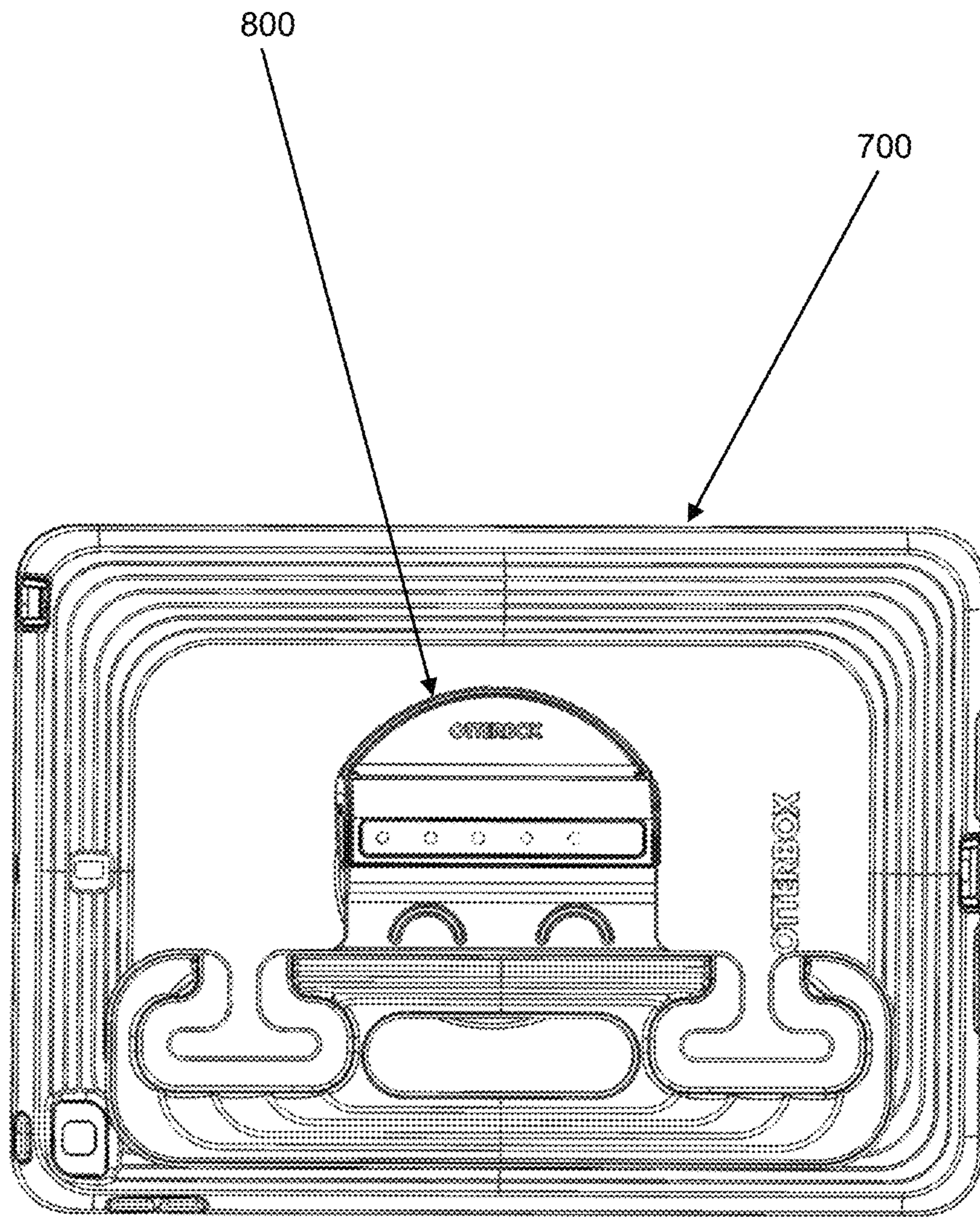

Figure 10

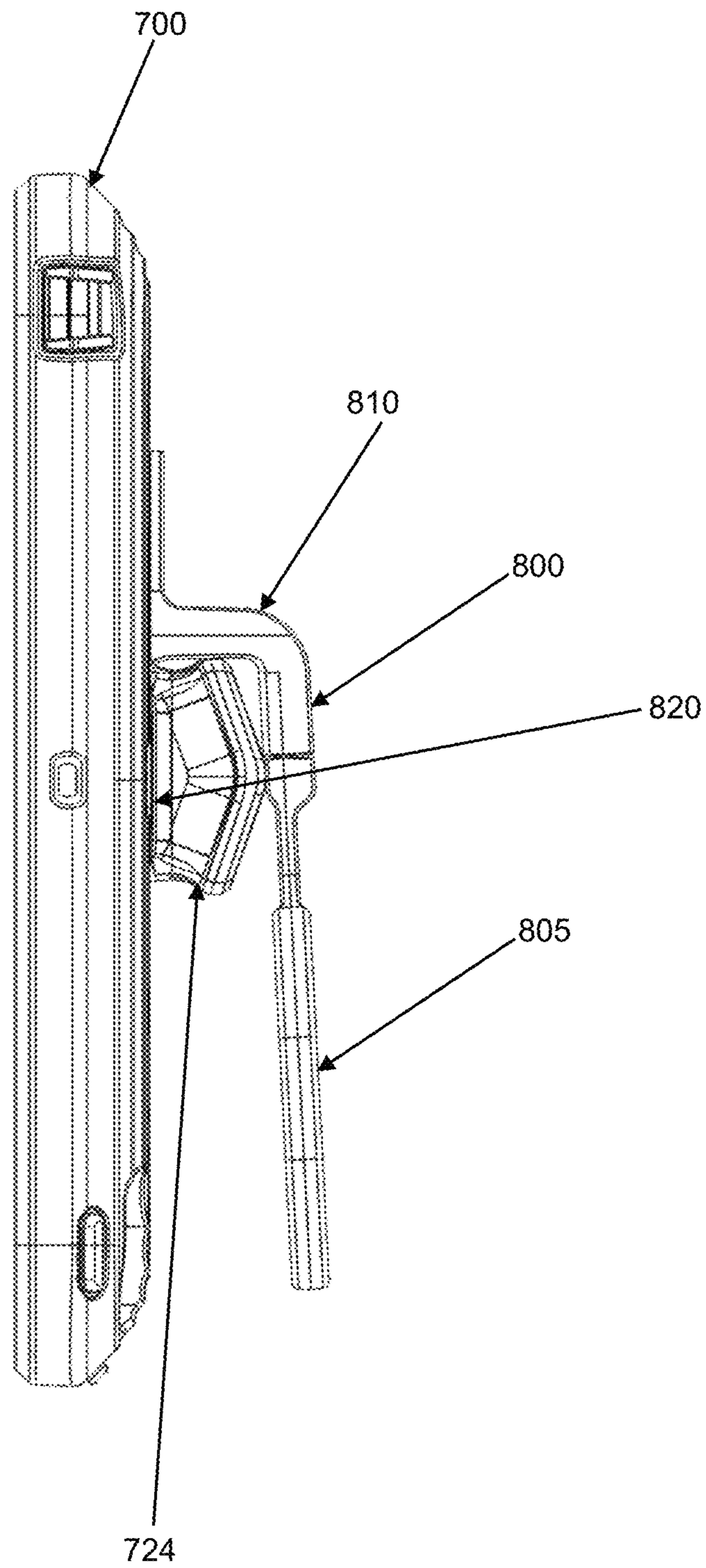

Figure 11

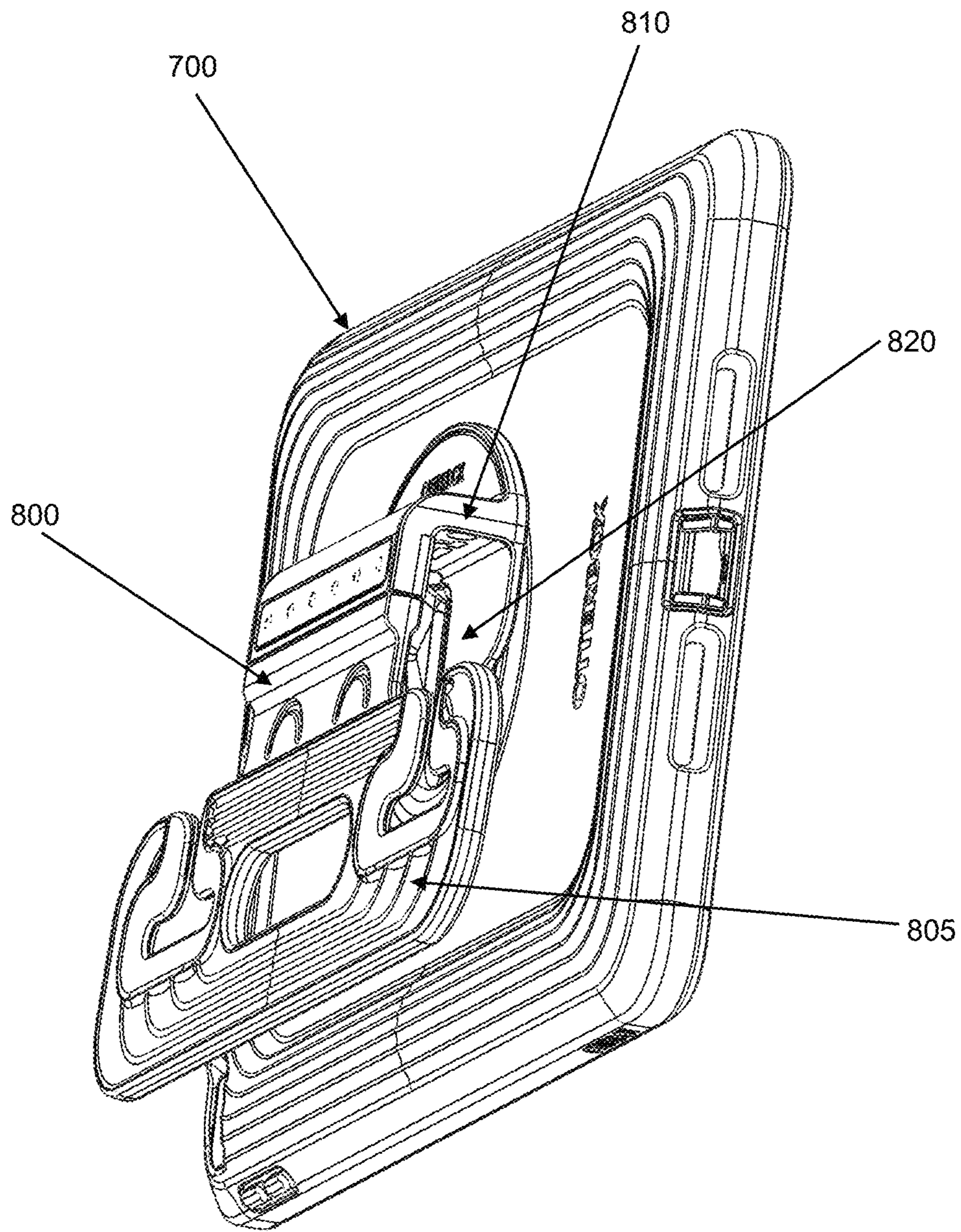

Figure 12

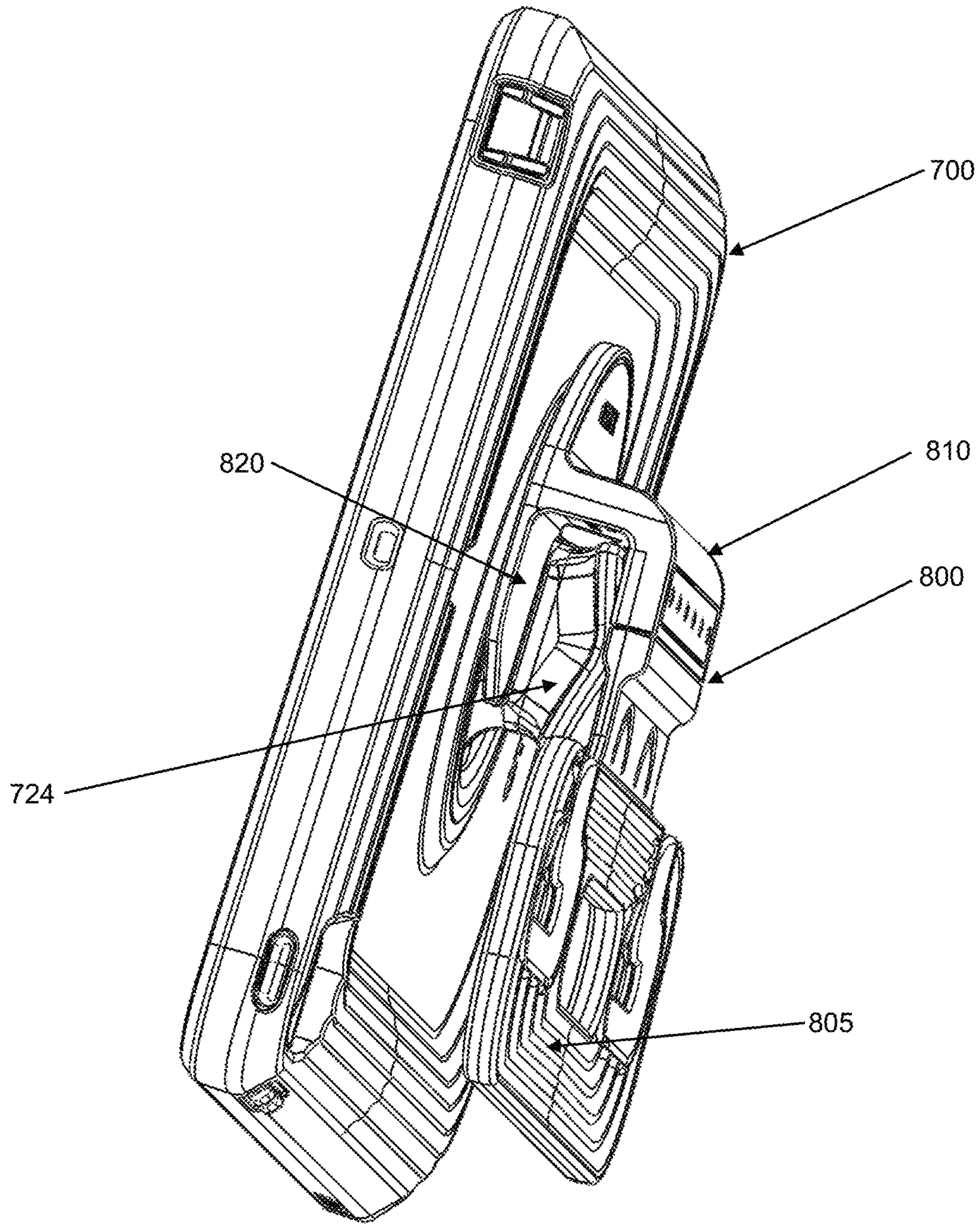

Figure 13

1**PROTECTIVE CASE SYSTEM FOR USE
WITH ELECTRONIC DEVICE**

RELATED APPLICATIONS

This application claims priority to U.S. patent application Ser. No. 17/168,258, filed Feb. 5, 2021, which claims priority to U.S. Provisional Patent Application No. 63/020,619, filed May 6, 2020, all of which are hereby incorporated by reference in their entireties.

BACKGROUND

Personal electronic devices are commonly used for communication and entertainment, as well as for a variety of other purposes. Examples of personal electronic devices include smartphones, tablet computers, gaming devices, audio players, video players, cameras, portable computers, two-way radios, GPS receivers, and/or other portable devices. Tablet computers have become more common and are often used by children, and often in a portable manner. It is not only desirable to have protective cases that protect these types of electronic devices from damage, but also include features for making them easier to carry as well as making them attachable to other objects.

SUMMARY

In one exemplary embodiment, a protective case system for use with an electronic device includes a protective case, a handle, and an adapter. The handle is removably attachable at a back surface of the protective case. The handle is configured for carrying the protective case and the electronic device when the handle is attached to the protective case and the electronic device is installed in the protective case. The adapter is removably attachable to the handle and is configured to function as a stand for the protective case. The adapter is further configured to removably attach to headrest posts of a seat.

In another exemplary embodiment, a protective case system for use with an electronic device includes a protective case, a handle, and an adapter. The protective case removably receives the electronic device and a display screen of the electronic device remains accessible when the electronic device is installed in the protective case. The handle is attached to and extends outward from a back surface of the protective case. The handle is configured for carrying the protective case and the installed electronic device. The adapter is configured to be removably attachable to the handle and bendable by a user to a plurality of positions. The adapter is configured to function as a multi-position stand for the protective case and the installed electronic device. The adapter is further configured to removably affix the protective case and the installed electronic device to a seat.

While several examples are provided above for purposes of illustration and description, other modifications and variations may be possible in view of the teachings herein. The embodiments described herein illustrate and explain the principles of the concept and its practical application to enable others skilled in the art to best utilize the invention.

BRIEF DESCRIPTION OF THE DRAWINGS

FIG. 1 illustrates an assembly including a case with a handle attachment;

2

FIG. 2A illustrates an adapter for use with the assembly of FIG. 1;

FIG. 2B illustrates another view of the adapter of FIG. 2A;

FIG. 2C illustrates another view of the adapter of FIG. 2A;

FIG. 2D illustrates the adapter of FIG. 2A with the handle attachment of FIG. 1;

FIG. 3A illustrates the assembly of FIG. 1 in use with the adapter of FIG. 2A;

FIG. 3B illustrates the assembly of FIG. 3A in a different orientation;

FIG. 3C illustrates another orientation of the assembly of FIGS. 3A and 3B;

FIG. 4 illustrates the assembly of FIGS. 3A-3C in use with a seat;

FIG. 5 illustrates another adapter for use with the assembly of FIG. 1; and

FIG. 6 illustrates the adapter of FIG. 5 with a handle attachment;

FIG. 7 illustrates a case with a handle;

FIG. 8 illustrates an arm for use with the case of FIG. 7;

FIG. 9 illustrates another view of the arm of FIG. 8;

FIG. 10 illustrates a rear view of the case of FIG. 7 with the arm of FIG. 8;

FIG. 11 illustrates a side view of the assembly of FIG. 10;

FIG. 12 illustrates a rear perspective view of the assembly of FIG. 10;

FIG. 13 illustrates an alternative rear perspective view of the assembly of FIG. 10.

DETAILED DESCRIPTION

Electronic devices are increasingly used with protective cases that protect the electronic devices from a variety of forces or elements such as: dropping, impact, scratching, water, dirt, dust, rain, snow, and/or chemicals. Children use electronic devices more and more frequently. Children often use tablet computers for entertainment, education, and/or gaming and may use them in a variety of different locations or settings. It is desirable to provide accessories which enable people, and particularly children, to more easily carry the electronic devices as well as use them in a variety of settings. Some desirable improvements include carrying handles, stands which can be adapted to a variety of situations, and adapters for conveniently attaching to a car headrest.

While most of the electronic device cases disclosed herein are described as “protective” cases, the apparatuses and techniques disclosed herein related to removable modules do not necessarily require that the case is protective and could apply to any type of electronic device case, cover, sleeve, sheath, attachment panel, etc. In other examples, the case may be water resistant or water proof for protecting the electronic device from water or other liquids. In yet other examples, the case may have other characteristics, such as but not limited to, chemical resistance and antimicrobial characteristics. Moreover, while the electronic device cases disclosed herein are generally understood to serve as after-market accessories for original equipment electronic devices (i.e., smartphones, tablet computers, gaming devices, audio players, video players, cameras, portable computers, two-way radios, GPS receivers, other portable devices, etc.), the apparatuses and techniques described herein could also be applied to the primary housings of original equipment electronic devices themselves. Further, while many of the uses described herein are described with respect to use by

kids or children, the apparatuses and techniques described herein are equally applicable to a variety of types of users or use scenarios.

FIG. 1 illustrates an exemplary case 100 for use with an electronic device 90 (not shown in FIG. 1, but shown in at least FIGS. 3B and 4), such as a smartphone, a tablet computer, a gaming device, an audio player, a video player, a camera, a portable computer, a two-way radio, a GPS receiver, and/or another portable device. Case 100 may include an inner liner and an outer shell. Case 100 may include various openings or apertures for accessing features of electronic device 90. Case 100 may also include features for actuating buttons or switches of electronic device 90. Case 100 may be protective, chemical-resistant, antibacterial, water-resistant, and/or waterproof.

As illustrated in FIG. 1, case 100 includes a receiver 110 for receiving a handle attachment 120. Receiver 110 may include a receiver area, a recess, a hole, a slot, one or more attachment mechanisms, threads, tabs, clips, snaps, ridges, a friction fit, and/or an interference fit for removably or releasably attaching handle attachment 120 to case 100. Handle attachment 120 includes a handle base 122 and a handle 124. Handle base 122 is received by or attaches to receiver 110 of case 100. In some examples, handle base 122 may temporarily or removably attach to receiver 110 in a rotational or twist-lock manner. While handle attachment 120 is attached to case 100, handle 124 can be used to carry case 100 along with any installed electronic device. The size, shape, and/or orientation of handle 124 may make it easier to carry case 100, particularly for a child. Handle 124 may also make it less likely that case 100 and the associated electronic device are accidentally dropped. Handle 124 may have other shapes, sizes, and/or configurations.

FIG. 2A illustrates an adapter 200 for use with case 100 and handle attachment 120. Adapter 200 includes an adapter foot portion 205 and an adapter body portion 210. While specific shapes are illustrated in the figures herein, many other shapes are possible. Adapter foot portion 205 includes post receivers 225 which are discussed in more detail with respect to FIG. 4. At an opposite end of adapter 200 from adapter foot portion 205, adapter 200 also includes clips 220 which are discussed in more detail with respect to FIG. 2D. Adapter 200 may also be referred to as an arm, a stand, or an accessory.

Adapter body 210 is formed, at least in part, from a flexible, bendable, or pliable material that is bendable and retains its shape after being bent, at least in part. Adapter body 210 may also later be bent to a different shape. Many materials are possible. In some cases, adapter body 210 may be formed from a shape memory material. FIG. 2B illustrates adapter 200 where adapter body 210 has been bent to a roughly 90 degree angle. It remains in that shape until it is bent back, or bent to another shape or configuration. FIG. 2C illustrates an opposite side view of adapter 200 of FIG. 2B.

FIG. 2D illustrates adapter 200 with handle attachment 120 inserted and temporarily attached, affixed, or retained by clips 220. Clips 220 may be flexible and may flex to removably or temporarily hold handle attachment 120 with an interference fit, a friction fit, and/or a snap fit such that it remains attached for use, but can be removed if a sufficient force is applied.

FIG. 3A illustrates the assembly of FIG. 2D with handle attachment 120 attached to case 100. In this configuration, adapter 200 acts as an adjustable stand for holding case 100 in a viewing orientation on a horizontal, or substantially horizontal, surface. Adapter body 210 can be bent to adjust

the viewing angle of the assembly. For example, FIG. 3B illustrates the assembly of FIG. 3A in a different viewing orientation. Adapter body 210 may be bent to different angles or positions to accommodate different situations or environments. When not in use as a stand, adapter 200 can be folded flat, or nearly flat, to reduce the amount of space it takes up. For example, FIG. 3C illustrates the assembly of FIG. 3B with adapter 200 folded flat, or substantially flat.

FIG. 4 illustrates the assembly of FIGS. 3A-3C in use with a seat 300. Seat 300 may be an automobile seat and includes a headrest 432 with headrest posts 434. Adapter 200 includes post receivers 225 to hang or temporarily attach adapter 200 to posts 434 for temporarily holding case 100 and electronic device 100 in a viewing position on or behind seat 430. Receivers 225 may include some flexible, spongy, or resilient material for accommodating a variety of post sizes and/or post spacings. The flexible or resilient material may enable the receivers 225 to accommodate these dimensional variations while still holding the assembly somewhat snugly in place when used with a particular seat. Receivers 225 may also include slots to accommodate headrest posts with various spacings. Case 100 can be attached to or removed from adapter 200 without necessarily removing adapter 200 from seat 430. As in other examples, adapter 200 and/or adapter body 210 can be bent to achieve a preferred viewing angle.

FIG. 5 illustrates another adapter 200 for use with the components or systems disclosed herein. In the example of FIG. 5, attachment mechanisms 320 provide a different method of removably attaching handle 124 and handle attachment 120. Attachment mechanisms 320 may provide an interference fit, a friction fit, and/or a snap fit with handle 124 and may do so in more than one axis. FIG. 6 illustrates handle attachment 120 and handle 124 removably attached to adapter 200. As in other examples, case 100 may be attached to handle attachment 120 and the whole assembly used as illustrated in FIGS. 3A-3C.

FIGS. 5 and 6 also illustrate that at least adapter foot 205 may be a multilayer structure. In one example, it may contain an out layer on each side that is made of a relatively hard or stiff material. An inner layer may be made of a more pliable or flexible material and the inner layer may extend further into post receiver areas 225 than the out layers. In this way, the flexible material of the inner layer can conform around posts of different sizes to provide a relatively snug fit while the outer layers still provide stiffness to the overall structure.

FIG. 7 illustrates an alternate case 700 for use with an electronic device, such as a tablet computer. Case 700 is an example of case 100 and may have any of the features, elements, characteristics, and/or functions of case 100, including combinations thereof. Case 700 includes a handle 724. Handle 724 is an example of handle 124 and may have any of the features, elements, characteristics, and/or functions of handle 124, including combinations thereof. Handle 724 may have other shapes or sizes. Case 700 covers at least portions of the sides and back of an electronic device installed in case 700.

FIG. 8 illustrates an adapter 800, which may also be referred to as an arm. Adapter 800 is an example of adapter 200 and may have any of the features, elements, characteristics, and/or functions of adapter 200, including combinations thereof. Adapter 800 includes an adapter foot portion 805 and an adapter body portion 810. While specific shapes are illustrated in the figures herein, many other shapes are possible. Adapter 800 may include portions that may each be rigid, flexible, resilient, or bendable. The bendable portions

5

are formed from a material which allows adapter **800** to be bent to a particular shape or angle by a user and stays in that general position when released by the user. Adapter foot portion **805** includes post receivers **825**. Post receivers **825** may include slots for accommodating headrest posts with various spacing. Adapter foot portion **805** may be formed from a flexible material that allows it to be temporarily bent to be removably engaged with headrest posts. The inner edges of post receivers may also include a more flexible, foamy, or spongy material to assist in maintaining a snug fit and/or to reduce unwanted vibration or movement around headrest posts.

FIG. **9** illustrates a rear view of the adapter **800** of FIG. **8**. Adapter **800** includes handle receiver **820** for receiving a shoulder portion of handle **724**. Handle receiver **820** may include a receiver area, a recess, a hole, a slot, one or more attachment mechanisms, threads, tabs, clips, snaps, ridges, a friction fit, and/or an interference fit for removably or releasably attaching or affixing adapter **800** to handle **724** and/or case **700**. Handle **724** may or may not rotate within handle receiver **820** and/or may have a locking feature to selectively and temporarily prohibit rotation.

FIG. **10** illustrates a rear view of case **700** with adapter **800** attached. FIG. **11** illustrates a side view of the assembly of FIG. **10**. Adapter foot portion **805** may be bent to various positions by a user similar to those of adapter **200** illustrated in FIGS. **2A-2D**. Adapter foot portion **805** may also be bent to various stand positions or to a stowed position similar to those of adapter **200** illustrated in FIGS. **3A-3C**.

FIG. **12** illustrates a rear perspective view of case **700** with adapter **800** attached. FIG. **13** illustrates an alternative rear perspective view of the assembly of FIG. **12**. Adapter **800** may be bent or positioned such that the assembly of FIGS. **10-13** may be used with a seat similar to the illustration of FIG. **4**. Other configurations are possible.

Any combination of the components or elements disclosed herein may be used together in the form of a system or kit. Any combination of the components disclosed herein may also be described as an accessory for an electronic device.

The elements, components, and steps described herein are meant to exemplify some types of possibilities. In no way should the aforementioned examples limit the scope of the invention, as they are only exemplary embodiments.

The phrases “in some embodiments,” “according to some embodiments,” “in the embodiments shown,” “in other embodiments,” “in some examples,” “in other examples,” “in some cases,” “in some situations,” “in one configuration,” “in another configuration,” and the like generally mean that the particular technique, feature, structure, or characteristic following the phrase is included in at least one embodiment of the present invention and/or may be included in more than one embodiment of the present invention. In addition, such phrases do not necessarily refer to the same embodiments or to different embodiments.

The foregoing disclosure has been presented for purposes of illustration and description. Other modifications and variations may be possible in view of the above teachings. The embodiments described in the foregoing disclosure were chosen to explain the principles of the concept and its practical application to enable others skilled in the art to best utilize the invention. It is intended that the claims be construed to include other alternative embodiments of the invention except as limited by the prior art.

What is claimed is:

1. A protective case system for use with an electronic device, the protective case system comprising:

6

a protective case for removably receiving the electronic device, wherein a display screen of the electronic device remains visible when the electronic device is installed in the protective case;

a handle attached to and extending outward from a back surface of the protective case, wherein the handle is configured for carrying the protective case; and

an adapter attached to the handle, wherein the adapter is configured to be bendable to a plurality of positions and is configured to function as a multi-position stand for the protective case and the installed electronic device, and wherein the adapter is further configured to removably affix the protective case and the installed electronic device to headrest posts of a seat.

2. The protective case system of claim **1** wherein the adapter includes two post receivers configured for each receiving a respective one of the headrest posts.

3. The protective case system of claim **2** wherein the two post receivers of the adapter are spaced apart a same distance as a distance between the headrest posts.

4. The protective case system of claim **2** wherein each post receiver comprises a slot for accommodating, alternately, two or more sets of headrest posts having differing spacing.

5. The protective case system of claim **2** wherein a portion of the adapter including the two post receivers is formed from a flexible material.

6. The protective case system of claim **1** wherein the handle is removably attached to the protective case.

7. The protective case system of claim **1** wherein the handle is permanently attached to the protective case.

8. The protective case system of claim **1** wherein the adapter is removably attachable to the handle.

9. The protective case system of claim **8** wherein the adapter is removably attachable to the handle with an interference fit.

10. The protective case system of claim **8** wherein the adapter is removably attachable to the handle with a friction fit.

11. The protective case system of claim **1** wherein the attached adapter is rotatable relative to the protective case.

12. The protective case system of claim **1** wherein the adapter is bendable to at least a stowed position and two different stand positions.

13. The protective case system of claim **1** wherein the adapter is bendable to change a viewing angle of the installed electronic device when the protective case system and the installed electronic device are removably attached to the headrest posts of the seat.

14. A protective case system for use with a tablet computer, the protective case system comprising:

a protective case adapted for covering at least a portion of the tablet computer and removably retaining the tablet computer;

a handle attached to and extending outward from the protective case, wherein the handle is adapted for carrying the protective case and the tablet computer when the tablet computer is installed in the protective case; and

an adapter adapted to be removably attachable to the handle, wherein the adapter is bendable to a plurality of positions and is adapted to function as a stand for the protective case and the installed tablet computer, and wherein the adapter is further adapted to removably attach the protective case and the installed tablet computer to a seat.

7

15. The protective case system of claim **14** wherein the attached adapter is rotatable relative to the protective case.

16. The protective case system of claim **14** wherein the adapter is bendable to at least a stowed position and two different stand positions, wherein each of the two different stand positions provides a different viewing angle for the installed tablet computer.

17. The protective case system of claim **16** wherein the adapter attaches to headrest posts of the seat and the adapter is bendable to change a viewing angle of the installed tablet computer when the protective case system is attached to the headrest posts of the seat.

18. An accessory for use with an electronic device, the accessory comprising:

a case for removably retaining and protecting the electronic device when the electronic device is installed in the case;

8

a handle attached to and extending outward from the case, wherein the handle is configured for holding or carrying the case and the installed electronic device; and an arm configured to attach to the handle, wherein the arm is bendable by a user to a plurality of positions, wherein the arm is configured to function as a multi-position stand for the case and the installed electronic device, and wherein the arm includes one or more slots configured to removably affix the case and the installed electronic device to an automobile seat.

19. The accessory of claim **18** wherein the arm includes a rigid portion and a flexible portion, wherein the flexible portion is configured to removably attach the arm to headrest posts of the automobile seat.

20. The accessory of claim **18** wherein the arm is removably attachable to the handle with one or more of an interference fit and a friction fit.

* * * * *