

US011962809B2

(12) **United States Patent**
Denoual et al.

(10) **Patent No.:** **US 11,962,809 B2**
(45) **Date of Patent:** **Apr. 16, 2024**

(54) **IMAGE DATA ENCAPSULATION WITH REFERENCED DESCRIPTION INFORMATION**

(71) Applicant: **CANON KABUSHIKI KAISHA**,
Tokyo (JP)

(72) Inventors: **Franck Denoual**, Saint Domineuc (FR);
Frédéric Maze, Langan (FR); **Jean Le Feuvre**, Cachan (FR); **Cyril Concolato**, Combs la Ville (FR)

(73) Assignee: **Canon Kabushiki Kaisha**, Tokyo (JP)

(*) Notice: Subject to any disclaimer, the term of this patent is extended or adjusted under 35 U.S.C. 154(b) by 0 days.

(21) Appl. No.: **17/820,697**

(22) Filed: **Aug. 18, 2022**

(65) **Prior Publication Data**

US 2022/0400288 A1 Dec. 15, 2022

Related U.S. Application Data

(63) Continuation of application No. 16/775,001, filed on Jan. 28, 2020, now Pat. No. 11,463,734, which is a (Continued)

(30) **Foreign Application Priority Data**

Mar. 25, 2014 (GB) 1405367
Jul. 1, 2014 (GB) 1411740

(51) **Int. Cl.**

H04N 21/4728 (2011.01)
H04N 19/105 (2014.01)
H04N 19/17 (2014.01)
H04N 19/46 (2014.01)
H04N 19/70 (2014.01)

(Continued)

(52) **U.S. Cl.**

CPC **H04N 19/70** (2014.11); **H04N 19/105** (2014.11); **H04N 19/17** (2014.11); **H04N 19/46** (2014.11); **H04N 21/4728** (2013.01); **H04N 21/8146** (2013.01); **H04N 21/8455** (2013.01); **H04N 21/8456** (2013.01); **H04N 21/85406** (2013.01); **H04N 19/172** (2014.11); **H04N 19/182** (2014.11); **H04N 19/184** (2014.11)

(58) **Field of Classification Search**

CPC H04N 19/70; H04N 19/105
See application file for complete search history.

(56) **References Cited**

U.S. PATENT DOCUMENTS

6,067,400 A * 5/2000 Saeki G09B 5/065
386/E9.036
8,472,549 B2 * 6/2013 Zhang H04L 27/3488
375/267

(Continued)

Primary Examiner — Irfan Habib

(74) *Attorney, Agent, or Firm* — Canon U.S.A., Inc. IP Division

(57) **ABSTRACT**

Methods of encapsulating a bitstream include generating reference information to enable image items identifying image portions of a bit stream to be referenced to corresponding description information. The resulting encapsulated file may also include information identifying a timed portion of the data stream corresponding to a video sequence. Description information may include spatial parameters, such as position and width and height of sub-parts of an overall image, and/or display parameters such as colour display, pixel aspect ratio, and clean aperture parameters.

28 Claims, 9 Drawing Sheets

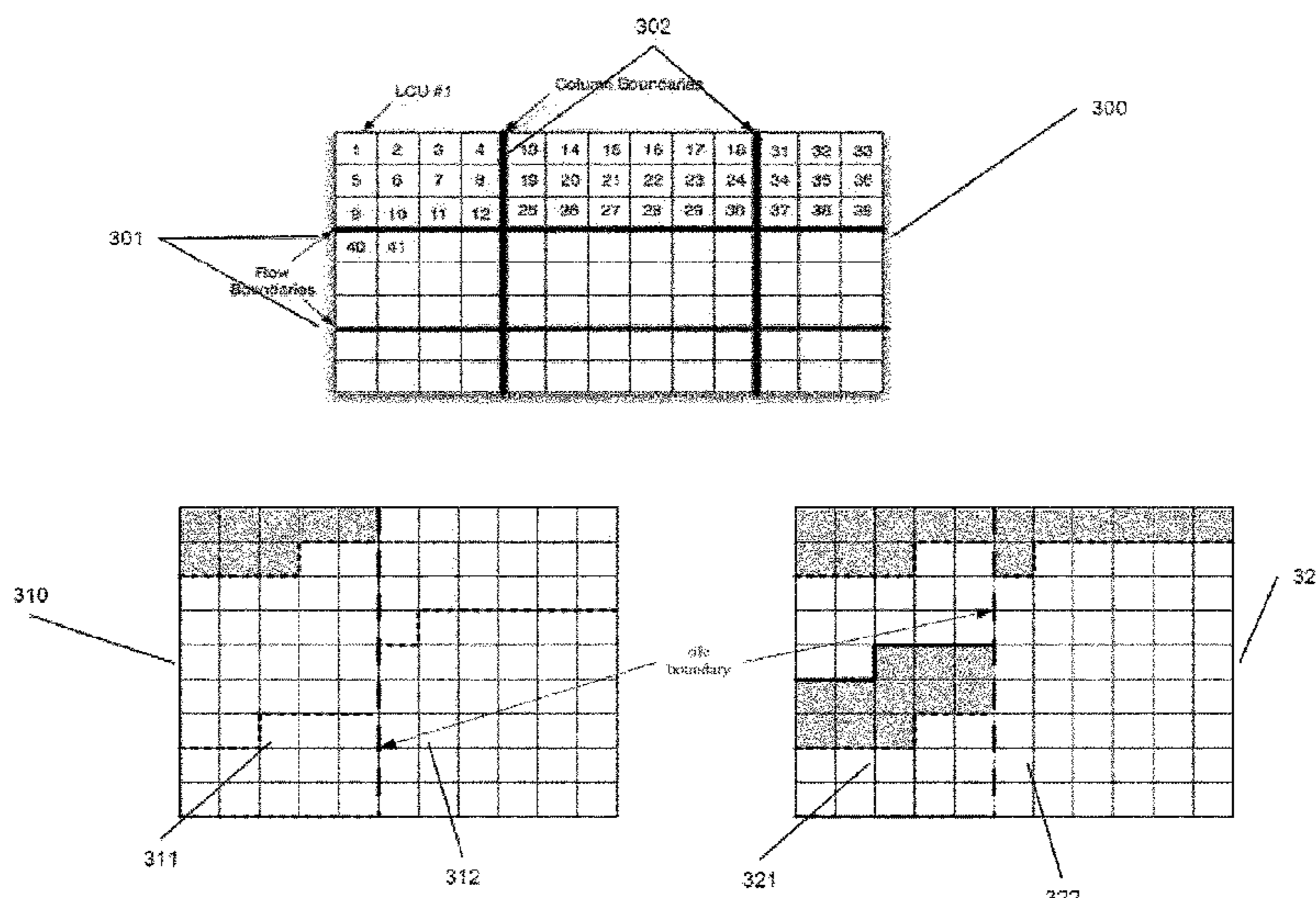

Related U.S. Application Data

continuation of application No. 16/213,333, filed on Dec. 7, 2018, now Pat. No. 10,582,221, which is a continuation of application No. 15/128,756, filed as application No. PCT/EP2015/056313 on Mar. 24, 2015, now Pat. No. 10,200,721.

(51) **Int. Cl.**

H04N 21/81 (2011.01)
H04N 21/845 (2011.01)
H04N 21/854 (2011.01)
H04N 19/172 (2014.01)
H04N 19/182 (2014.01)
H04N 19/184 (2014.01)

(56)

References Cited

U.S. PATENT DOCUMENTS

8,614,960 B2 * 12/2013 Arkhipenkov H04J 3/047
 370/252
 8,780,999 B2 * 7/2014 Chen H04N 21/4345
 375/240.25
 9,106,895 B2 * 8/2015 Won H04N 21/234327
 9,432,664 B2 * 8/2016 Wang H04N 19/30
 9,591,383 B2 * 3/2017 Maze H04L 65/70
 9,621,894 B2 * 4/2017 Seregin H04N 19/18
 9,667,941 B2 * 5/2017 Hattori H04N 13/161
 9,848,217 B2 * 12/2017 Choi H04N 21/234327
 9,906,807 B2 * 2/2018 Denoual H04N 21/845
 11,070,893 B2 * 7/2021 Denoual H04N 21/8456
 2001/0004404 A1 * 6/2001 Itokawa H04N 9/8042
 375/E7.211
 2002/0071485 A1 * 6/2002 Caglar H04N 19/34
 375/E7.091

2004/0131269 A1 * 7/2004 Kobayashi H04N 19/13
 375/E7.199
 2006/0284994 A1 * 12/2006 Kim H04N 1/00442
 348/231.2
 2007/0183495 A1 * 8/2007 Kim H04N 19/597
 375/E7.181
 2009/0222855 A1 * 9/2009 Vare H04L 12/189
 725/39
 2009/0323809 A1 * 12/2009 Raveendran H04N 19/137
 375/E7.104
 2010/0254620 A1 * 10/2010 Iwahashi H04N 19/61
 382/233
 2010/0316122 A1 * 12/2010 Chen H04N 21/8451
 375/E7.076
 2010/0322317 A1 * 12/2010 Yoshimatsu H04N 19/44
 375/240.24
 2012/0036544 A1 * 2/2012 Chen H04N 21/435
 725/109
 2012/0133736 A1 * 5/2012 Nishi H04N 19/70
 348/43
 2012/0137122 A1 * 5/2012 Lu H04N 21/2362
 713/150
 2012/0155782 A1 * 6/2012 Choi H04N 19/597
 382/238
 2012/0162228 A1 * 6/2012 Yamane H04N 19/33
 345/428
 2013/0259130 A1 * 10/2013 Coban H04N 19/70
 375/240.15
 2014/0126640 A1 * 5/2014 Samuelsson H04N 19/46
 375/240.16
 2015/0269736 A1 * 9/2015 Hannuksela H04N 13/161
 345/419
 2016/0255381 A1 * 9/2016 Denoual H04N 21/234345
 709/231
 2017/0134756 A1 * 5/2017 Denoual H04N 19/105
 2018/0007407 A1 * 1/2018 Maze H04N 19/46

* cited by examiner

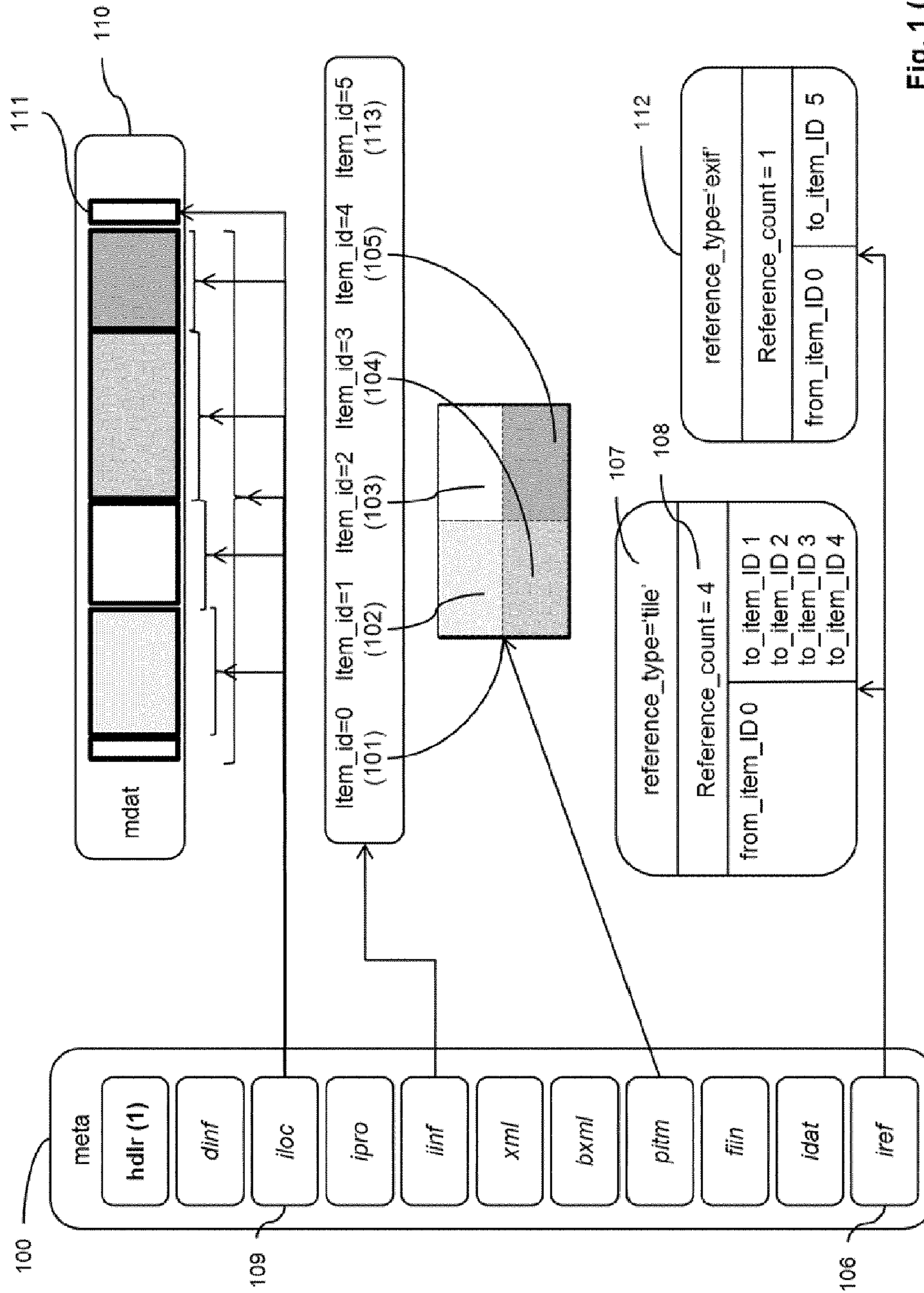

Fig. 1 (prior art)

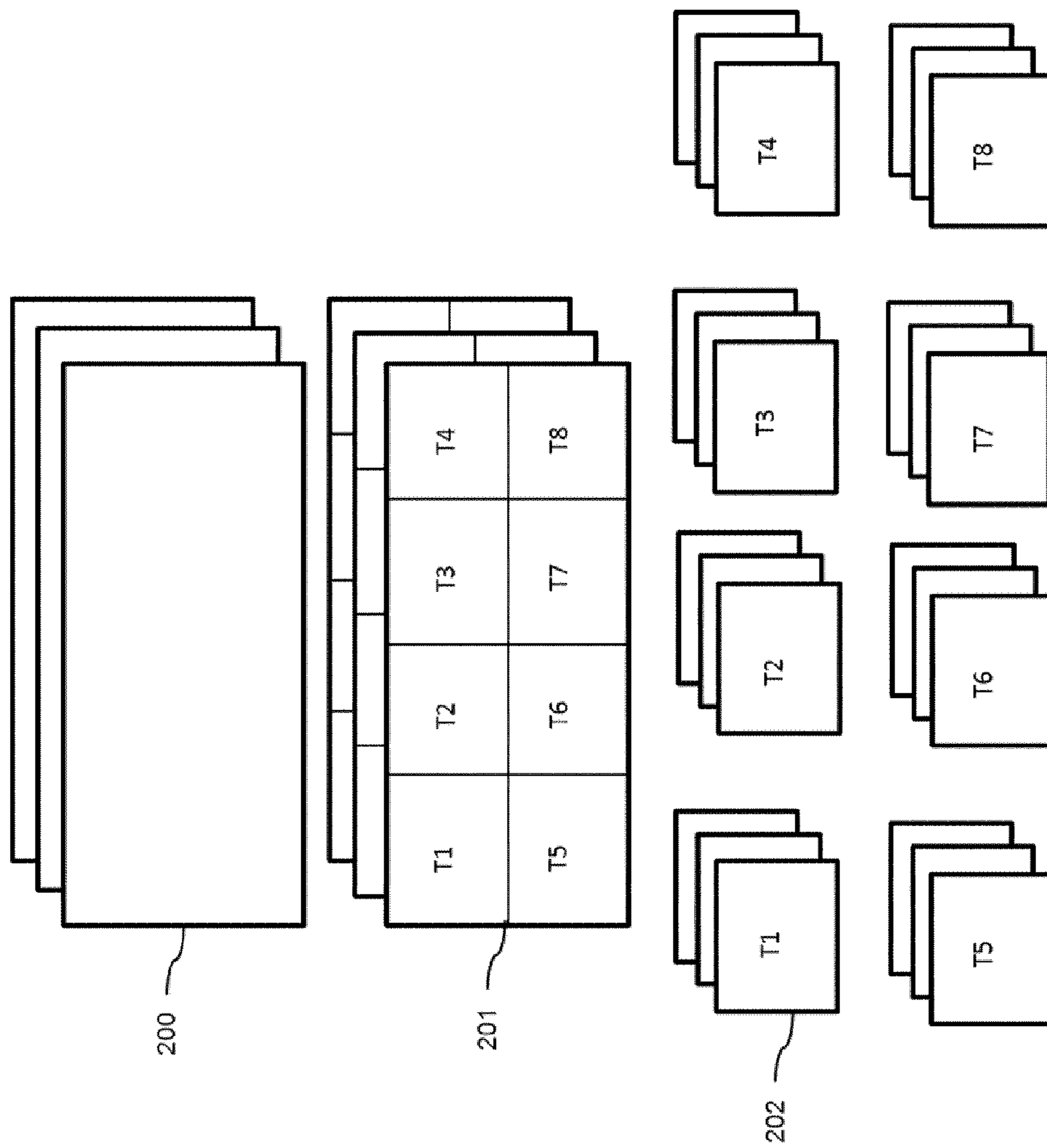

Fig. 2

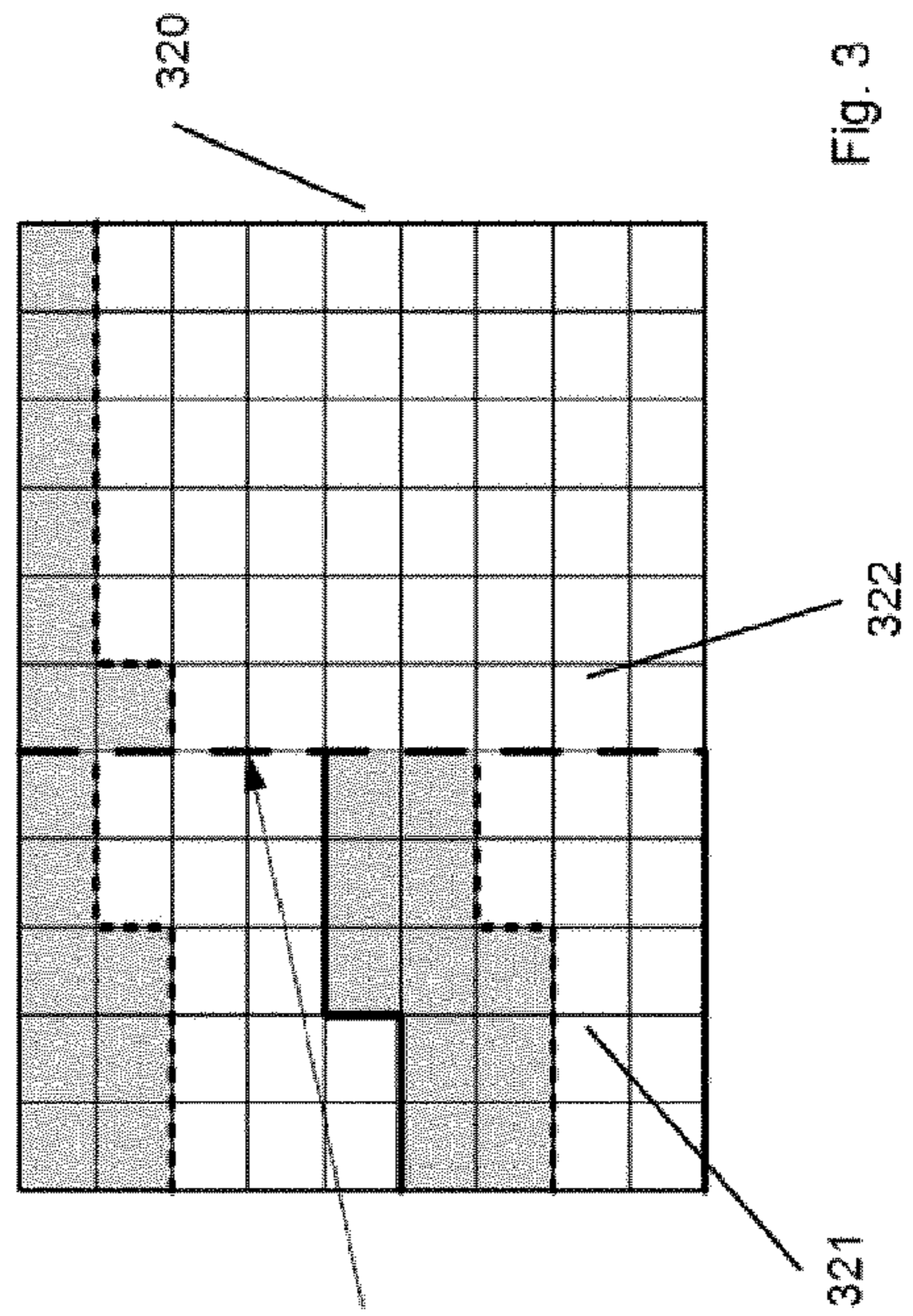
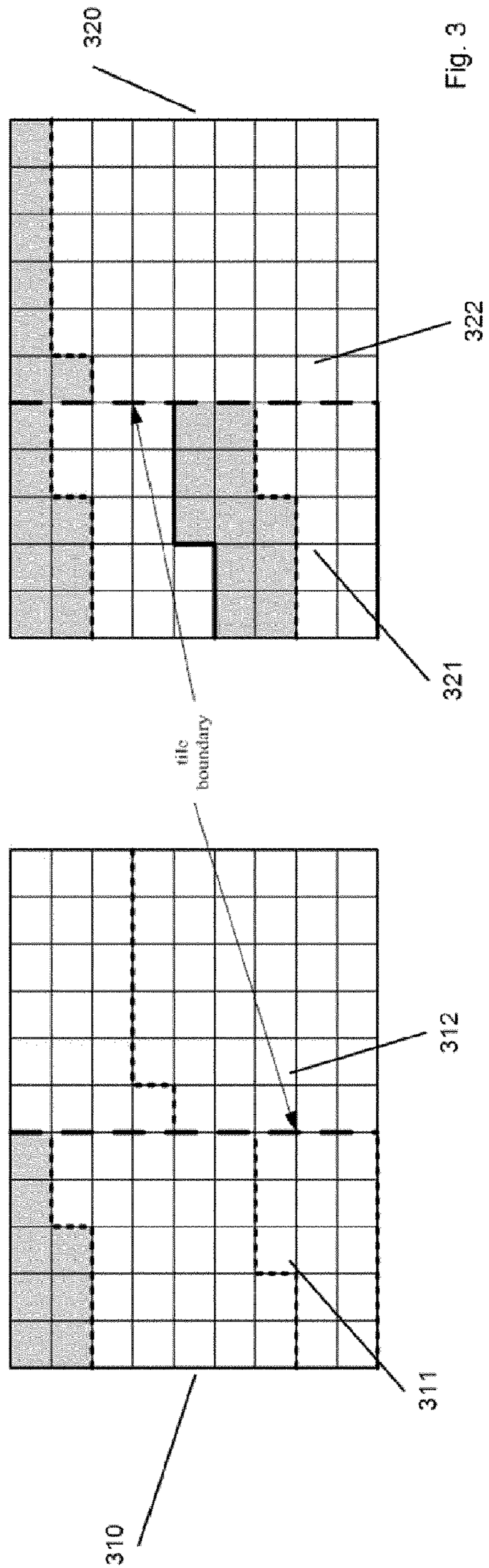
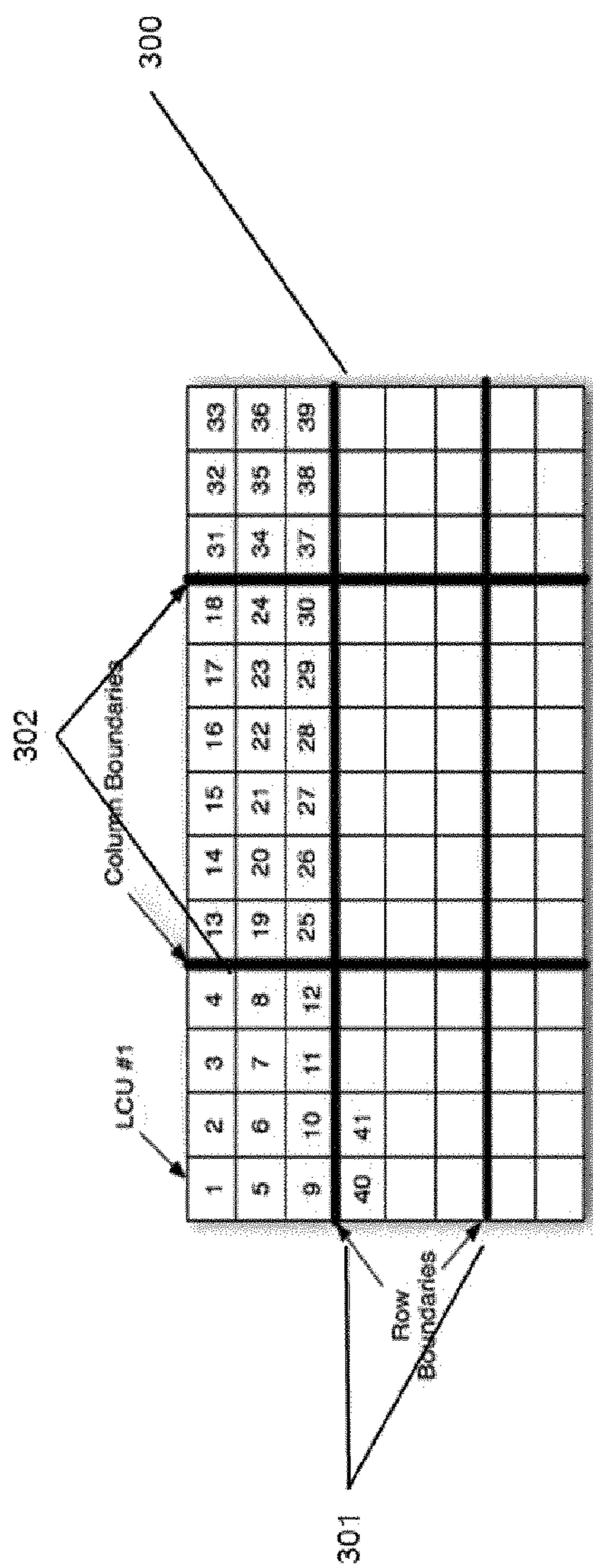

Fig. 3

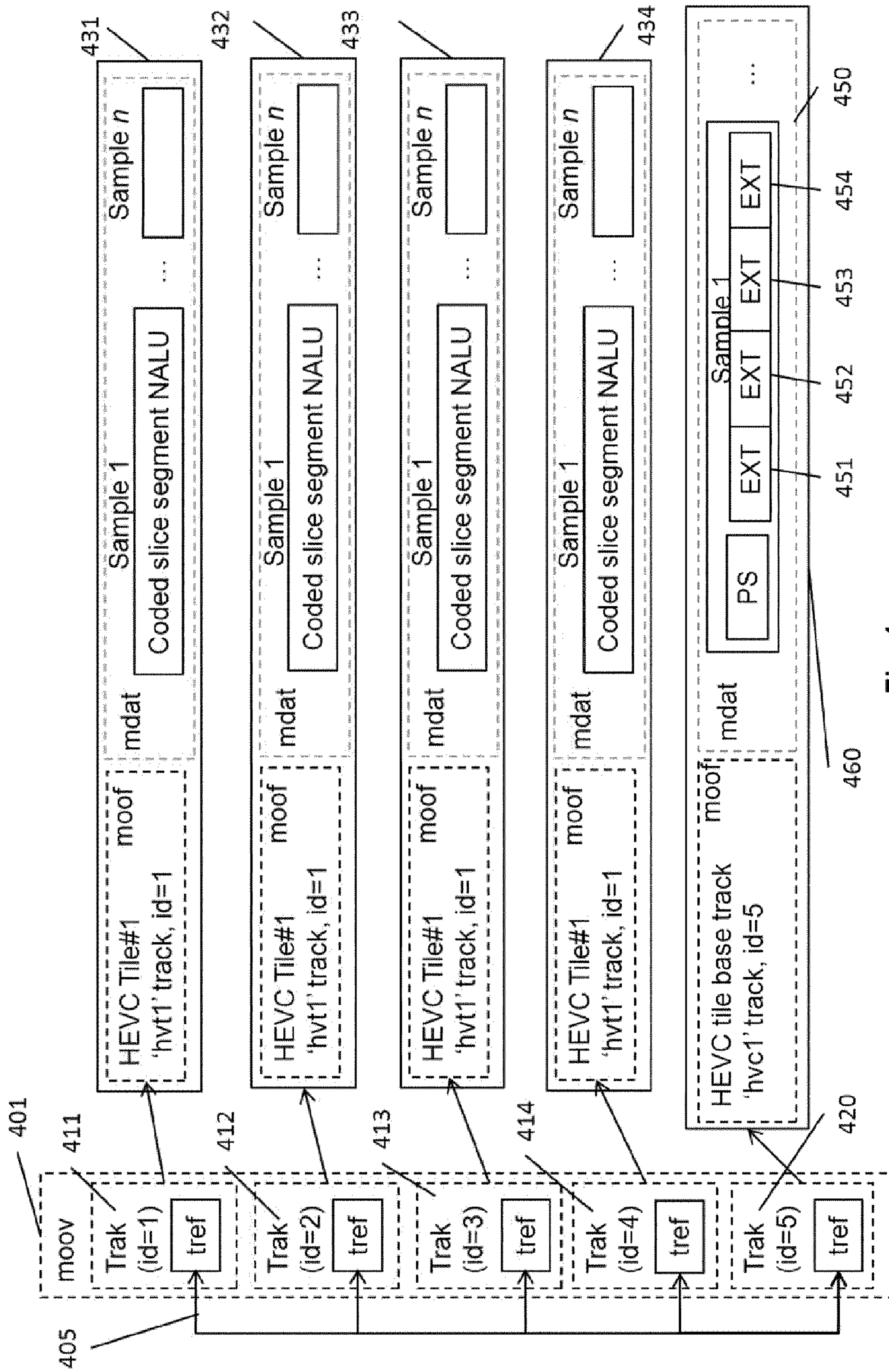

Fig. 4

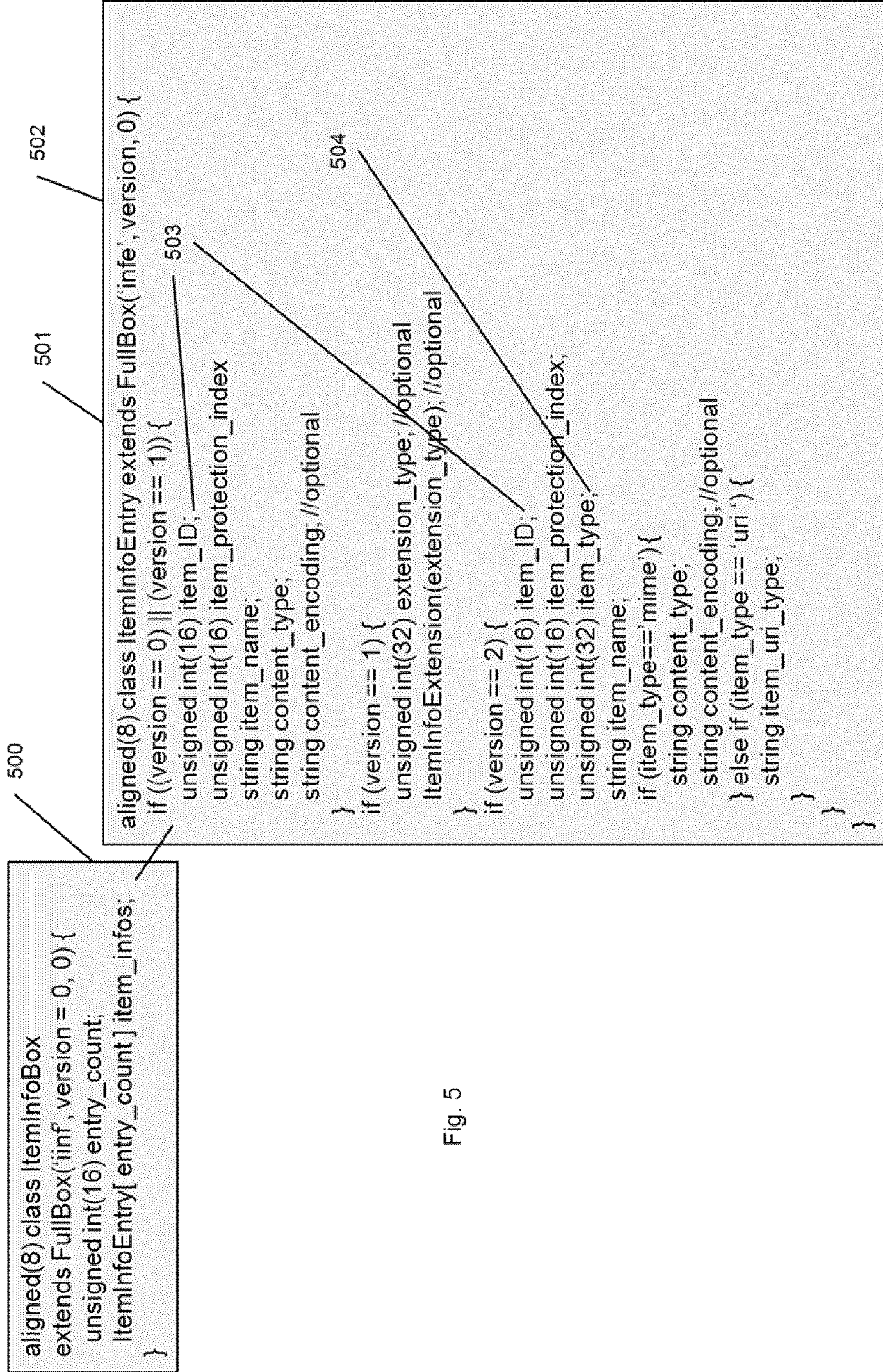

Fig. 5

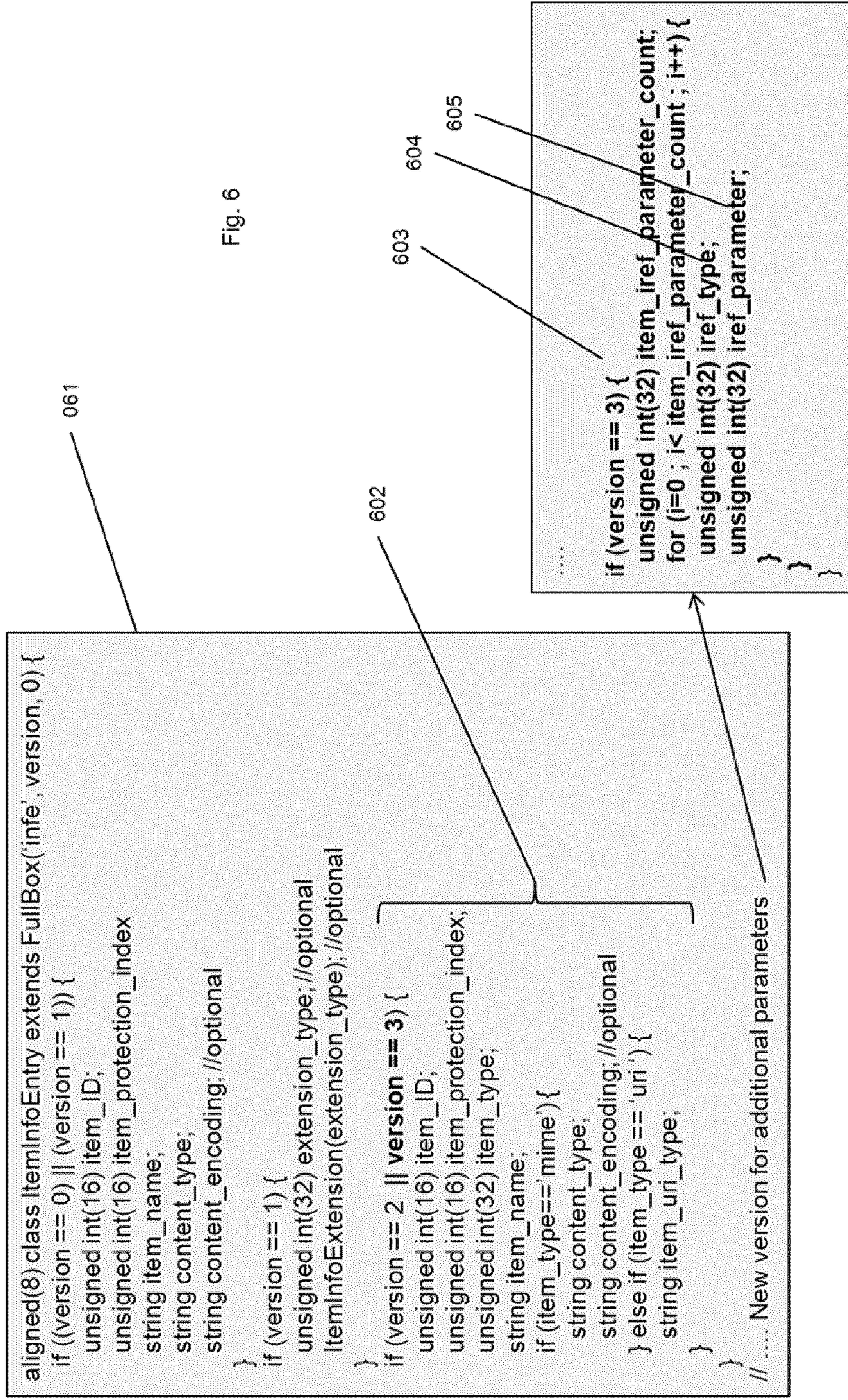

Fig. 6

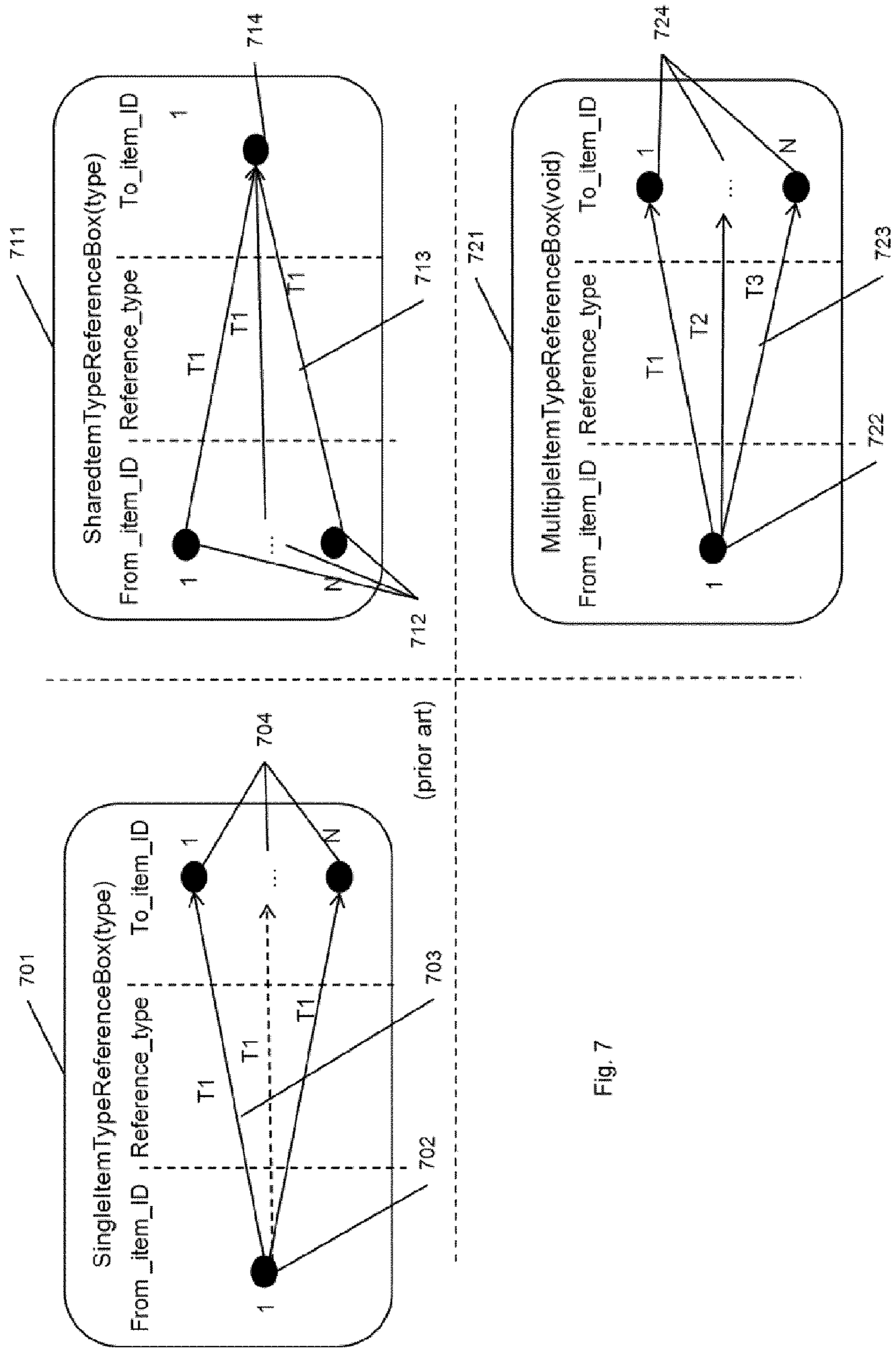

Fig. 7

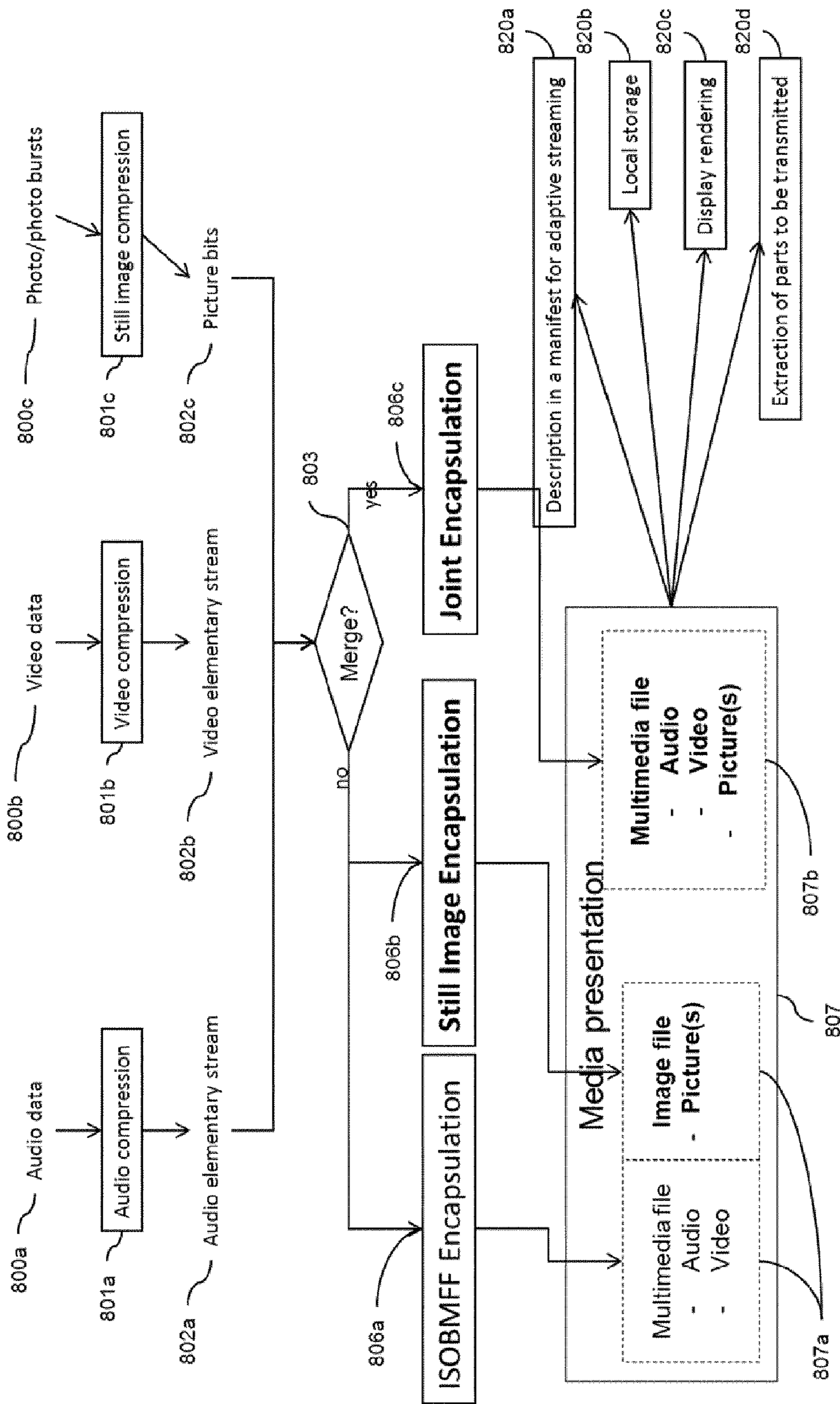

Fig. 8

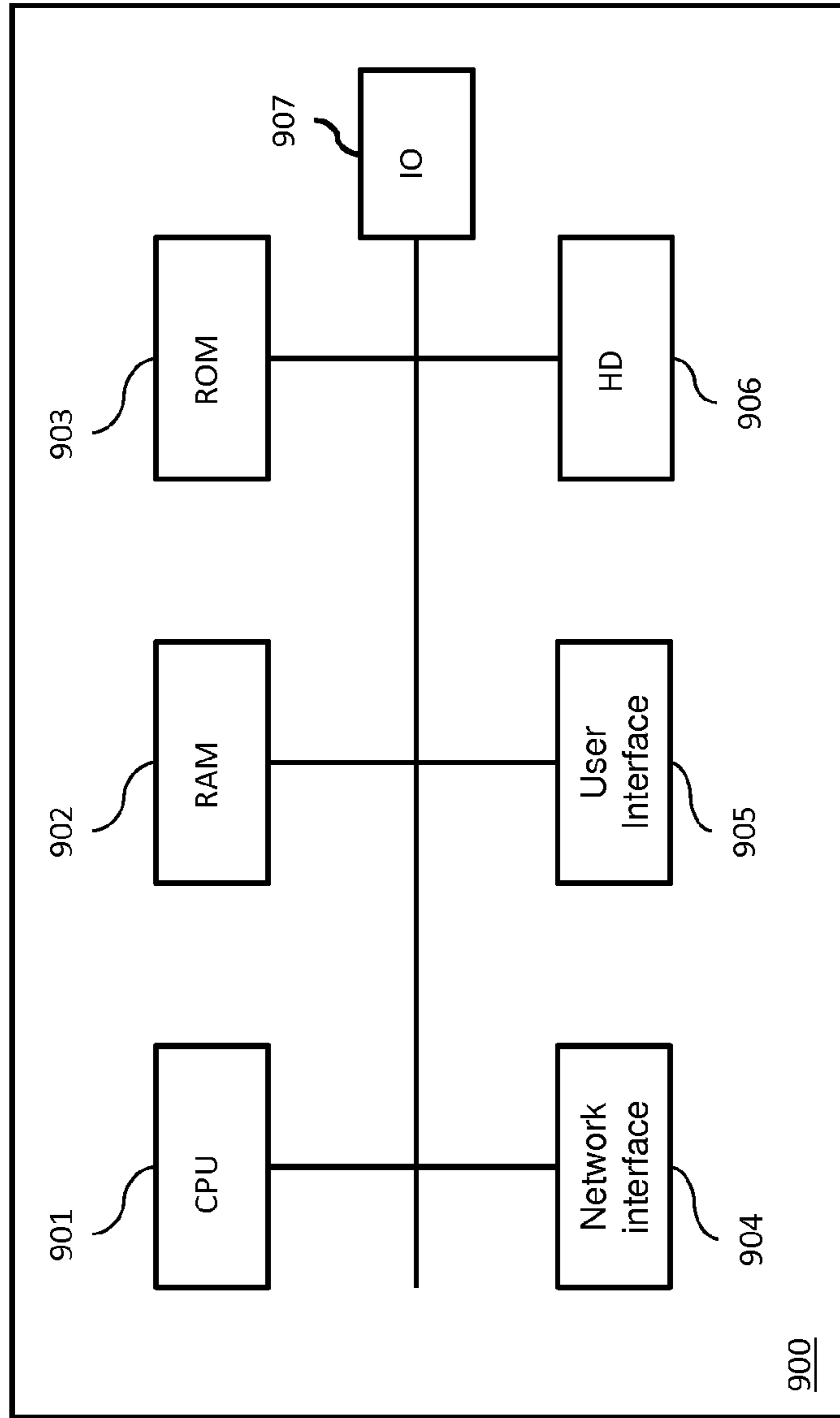

Figure 9

IMAGE DATA ENCAPSULATION WITH REFERENCED DESCRIPTION INFORMATION

CROSS-REFERENCE TO RELATED APPLICATIONS

This application is a continuation of U.S. patent application Ser. No. 16/775,001, filed on Jan. 28, 2020, which is continuation of U.S. patent application Ser. No. 16/213,333, filed on Dec. 7, 2018, now issued as U.S. Pat. No. 10,582,221 on Mar. 3, 2020, which is continuation of U.S. patent application Ser. No. 15/128,756, filed on Sep. 23, 2016, now issued as U.S. Pat. No. 10,200,721 on Feb. 5, 2019, which is a National Phase application of PCT Application No. PCT/EP2015/056313, filed on Mar. 24, 2015 and which claims the benefit under 35 U.S.C. § 119(a)-(d) of United Kingdom Patent Application No. GB1405367.2, filed on Mar. 25, 2014, and GB1411740.2, filed on Jul. 1, 2014. The above cited patent applications are incorporated herein by reference in their entirety.

FIELD OF THE INVENTION

The present invention relates to the storage of image data, such as still images, bursts of still images or video data in a media container with descriptive metadata. Such metadata generally provides easy access to the image data and portions of the image data.

BACKGROUND OF THE INVENTION

Some of the approaches described in this section could be pursued, but are not necessarily approaches that have been previously conceived or pursued. Therefore, the approaches described in this section are not necessarily prior art to the claims in this application and are not admitted to be prior art by inclusion in this section.

The HEVC standard defines a profile for the encoding of still images and describes specific tools for compressing single still images or bursts of still images. An extension of the ISO Base Media File Format (ISOBMFF) used for such kind of image data has been proposed for inclusion into the ISO/IEC 23009 standard, in Part 12, under the name: "Image File Format". The standard covers two forms of storage corresponding to different use cases:

- the storage of image sequences, with timing that is optionally used at the decoder, and in which the images may be dependent on other images, and
- the storage of single images, and collections of independently coded images.

In the first case, the encapsulation is close to the encapsulation of the video tracks in the ISO Base Media File Format (see document «Information technology—Coding of audio-visual objects—Part 12: ISO base media file format», ISO/IEC 14496-12:2008, Third edition, October 2008), and the same tools and concepts are used, such as the 'trak' boxes and the sample grouping for description. The 'trak' box is a file format box that contains sub boxes for describing a track, that is to say, a timed sequence of related samples.

In the second case, a set of ISOBMFF boxes, the 'meta' boxes are used. These boxes and their hierarchy offer less description tools than the 'trak' boxes and relate to "information items" or "items" instead of related samples.

The image file format can be used for locally displaying multimedia files or for streaming multimedia presentations. HEVC Still Images have many applications which raise many issues.

Image bursts are one application. Image bursts are sequences of still pictures captured by a camera and stored as a single representation (many picture items referencing a block of data). Users may want to perform several types of actions on these pictures: select one as thumbnail or cover, apply effects on these pictures or the like.

There is thus a need for descriptive metadata for identifying the list of pictures with their corresponding bytes in the block of data.

Computational photography is another application. In computational photography, users have access to different resolutions of the same picture (different exposures, different focuses etc.). These different resolutions have to be stored as metadata so that one can be selected and the corresponding piece of data can be located and extracted for processing (rendering, editing, transmitting or the like).

With the increase of picture resolution in terms of size, there is thus a need for providing enough description so that only some spatial parts of these large pictures can be easily identified and extracted.

Another kind of applications is the access to specific pictures from a video sequence, for instance for video summarization, proof images in video surveillance data or the like.

For such kind of applications, there is a need for image metadata enabling to easily access the key images, in addition to the compressed video data and the video tracks metadata.

In addition, professional cameras have reached high spatial resolutions. Videos or images with 4K2K resolution are now common. Even 8 k4 k videos or images are now being common. In parallel, video are more and more played on mobile and connected devices with video streaming capabilities. Thus, splitting the videos into tiles becomes important if the user of a mobile device wants to display or wants to focus on sub-parts of the video by keeping or even improving the quality. By using tiles, the user can therefore interactively request spatial sub-parts of the video.

There is thus a need for describing these spatial sub-parts of the video in a compact fashion in the file format in order to be accessible without additional processing other than simply parsing metadata boxes. For images corresponding to the so-described videos, it is also of interest for the user to access to spatial sub-parts.

The ISO/IEC 23009 standard covers two ways for encapsulating still images into the file format that have been recently discussed.

One way is based on 'trak' boxes, and the notion of timed sequence of related samples with associated description tools, and another is based on 'meta' boxes, based on information items, instead of samples, providing less description tools, especially for region of interest description and tiling support.

There is thus a need for providing tiling support in the new Image File Format.

The use of tiles is commonly known in the prior art, especially at compression time. Concerning their indexation in the ISO Base Media File format, tiling descriptors exist in drafts for amendment of Part 15 of the ISO/IEC 14496 standard "Carriage of NAL unit structured video in the ISO Base Media File Format".

However, these descriptors rely on 'trak' boxes and sample grouping tools and cannot be used in the Still Image

File Format when using the ‘meta’ based approach. Without such descriptors, it becomes complicated to select and extract tiles from a coded picture stored in this file format.

FIG. 1 illustrates the description of a still image encoded with tiles in the ‘meta’ box (100) of ISO Base Media File Format, as disclosed in MPEG contribution m32254.

An information item is defined for the full picture 101 in addition to respective information items for each tile picture (102, 103, 104 and 105). The box (106), called ‘ItemReferenceBox’, from the ISO BMFF standard is used for indicating that a ‘tile’ relationship (107) exists between the information item of the full picture and the four information items corresponding to the tile pictures (108). Identifiers of each information item are used so that a box (109), called ‘ItemLocationBox’, provides the byte range(s) in the encoded data (110) that represent each information item. Another box “ItemReferenceBox” (112) is used for associating EXIF metadata (111) with the information item for the full picture (101) and a corresponding data block (111) is created in the media data box (110). Also, an additional information item (113) is created for identifying the EXIF metadata.

Even if the full picture and its tiles are introduced as information items, no tiling information is provided here. Moreover, when associating additional metadata with an information item (like EXIF), no data block referenced using an additional ItemReferenceBox’ is created.

Reusing information on tiling from EXIF and reusing the mechanism defined in the Still Image File format draft wouldn’t make it possible to describe non-regular grid with existing EXIF tags.

Thus, there is still a need for improvements in the file format for still images, notably HEVC still images. In particular, there is a need for methods for extracting a region of interest in still Images stored with this file format.

SUMMARY OF THE INVENTION

According to a first aspect of the invention there is provided a method of encapsulating an encoded bitstream representing one or more images, the method comprising:

- providing tile description information comprising spatial parameters for dividing an image area into one or more tiles;
- providing tile picture item information identifying a portion of the bit stream representing a tile of a single image;
- providing reference information linking said tile picture item to said tile description information, and
- outputting said bistream together with said provided information as an encapsulated data file.

The output may be performed according to a defined standard, and is readable and decodable.

A method according to the first aspect makes it possible to easily identify, select and extract tiles from, for example, ultra-high resolution images (4K2K, 8K4K . . .), by parsing syntax elements and without complex computation.

The description tools of the metadata boxes of the ISO Base Media File Format can be extended. In particular, it makes it possible to associate tile description with information items.

Parts of the ‘meta’ boxes hierarchy can be extended so as to provide additional description tools and especially to support tile-based access within still images.

A method according to the first aspect makes it possible to easily extract, from an encoded HEVC Still Picture, a region of interest based on HEVC tiles.

Embodiments of the invention provide tile description support and tile access for still images encoded according to the HEVC standard.

This makes it possible to preserve the region of interest feature available for video tracks for still image. In general, parts of a still picture corresponding to a user-defined region of interest can be identified and easily extracted for rendering or transmission to media players.

For example, said encapsulated encoded bitstream also contains information identifying a timed portion of said data stream corresponding to a video sequence.

Therefore, double indexing can be provided on a single piece of data that provides the same access facilities to the video as in some still images that are part of this video.

For example, tile description information includes a set of spatial parameters for each tile picture item.

For example, tile description information includes spatial parameters common to more than one tile picture item.

For example, tile description information is embedded in the bitstream.

For example, tile description information is provided as metadata.

For example, the reference information includes a reference type, and additional descriptive metadata including said tile description information.

For example, the reference information includes a reference type, and a reference parameter relating to said tile description information

The method may further comprise providing a metadata item for referencing said tile description information in the bitstream.

For example, tile picture items are grouped and wherein the reference information is provided for linking a group of tile picture items to said tile description information.

For example, all references linking metadata items to another item are included in a single reference box in the encapsulated data file.

For example, all the relationships from one item, of any type, are stored in a single item information descriptor.

For example, wherein said outputting is performed by a server module for adaptive streaming.

For example, said outputting is performed for storage into a memory.

For example, said outputting is performed to a display module for display.

For example, said outputting is performed by a communication module for transmission.

For example, said encapsulated data file corresponds to a standardized file format.

For example, said encapsulated data file is decodable and playable.

According to a second aspect of the invention there is provided a method of processing an encapsulated data file including an encoded bitstream corresponding to one or more images, and information including tile description information comprising spatial parameters for dividing an image area into one or more tiles, the method comprising:

- selecting an image region of interest,
- identifying, from said tile description information, tiles which correspond to the selected area of interest,
- selecting one or more tile picture items linked to said identified tiles, each tile picture item identifying a portion of the bitstream representing a tile of a single image,
- extracting a portion of the bitstream identified by the selected tile picture item(s), and
- outputting said extracted bitstream portion.

5

For example, wherein said outputting is performed by a server module for adaptive streaming.

For example, said outputting is performed for storage into a memory.

For example, said outputting is performed to a display module for display.

For example, said outputting is performed by a communication module for transmission.

For example, said encapsulated data file corresponds to a standardized file format.

For example, said encapsulated data file is decodable and playable.

According to a third aspect of the invention there is provided a method of processing image data representing at least one image for encapsulation into an encapsulation file, the method comprising:

obtaining a spatial subdivision of said at least one image into a plurality of image portions,

determining at least one portion identification data identifying a data portion within said image data, representing an image portion of said plurality,

encapsulating said image data into said encapsulation file along with at least:

subdivision description data representing said subdivision of said at least one image,

said portion identification data, and

reference data linking said subdivision description data and said portion identification data.

For example, said image data represent a plurality of images of a video sequence, and the method further comprises determining at least one time identification data identifying a data portion within said image data, representing a time portion of said video sequence, and said image data are encapsulated along with said time identification data.

For example, a plurality of portion identification data are determined respectively representing a same image portion of the images of said time portion of said video sequence.

For example, at least said subdivision description data is encapsulated as metadata to the image data.

For example, said spatial subdivision is embedded in a bitstream containing said image data.

For example, respective portion identification data are determined for each image portion.

For example, common portion identification data are determined for a plurality of image portions.

The method may further comprise outputting said encapsulation file into a bitstream for adaptive streaming by a server device.

The method may further comprise outputting said encapsulation file into a bitstream for transmission to a display device for displaying said image data.

The method may further comprise outputting said encapsulation file into a bitstream for transmission to a client device.

The method may further comprise storing said encapsulation file into a storage device.

For example, the reference data includes a reference type, and additional descriptive metadata including said subdivision description data.

For example, the reference data includes a reference type and a reference parameter relating to said subdivision description data.

For example, said subdivision description data is referenced in a metadata item.

6

For example, portion identification data are grouped and wherein the reference data links a group of portion identification data to said portion identification data.

For example, said encapsulated file comprises a single reference box containing all reference data for the image data.

For example, said encapsulated file comprises a description containing a representation of the relationships between said subdivision description data, portion identification data and reference data.

According to a fourth aspect of the invention, there is provided a method of processing an encapsulation file comprising:

image data representing at least one image,

subdivision description data representing a spatial subdivision of said at least one image into a plurality of image portions,

at least one portion identification data identifying a data portion within said image data, representing an image portion of said plurality, and

reference data linking said subdivision description data and said portion information,

the method comprising:

determining a region of interest in said at least one image, determining, based on said subdivision description data, at least one image portion, belonging to said region of interest,

accessing, based on said reference data, at least one portion identification data identifying a data portion within said image data, representing said at least one image portion belonging to said region of interest, and extracting said data portion within said image data.

For example, said image data comprise a plurality of images of a video sequence, and said encapsulation file further comprises at least one time identification data identifying a data portion within said image data, representing a time portion of said video sequence, the region of interest being determined for the images of said time portion of said video sequence and the data portions corresponding to said region of interest in a plurality of images of said time portion of said video sequence are extracted.

For example, a plurality of portion identification data respectively represent a same image portion of the images of said time portion of said video sequence.

For example, at least said subdivision description data is encapsulated as metadata to the image data.

For example, respective portion identification data are determined for each image portion.

For example, common portion identification data are determined for a plurality of image portions.

The method may further comprise receiving said encapsulation file as a bitstream adaptively streamed by a server device.

The method may further comprise displaying said region of interest.

For example, the reference data includes a reference type, and additional descriptive metadata including said subdivision description data.

For example, the reference data includes a reference type and a reference parameter relating to said subdivision description data.

For example, said subdivision description data is referenced in a metadata item.

For example, portion identification data are grouped and wherein the reference data links a group of portion identification data to said portion identification data.

For example, said encapsulated file comprises a single reference box containing all reference data for the image data.

For example, said encapsulated file comprises a description containing a representation of the relationships between said subdivision description data, portion identification data and reference data.

According to a fifth aspect of the invention, there is provided a device configured to implement a method according to the first aspect.

The device may comprise:

a processing unit configured to provide tile description information comprising spatial parameters for dividing an image area into one or more tiles; provide tile picture item information identifying a portion of the bit stream representing a tile of a single image; provide reference information linking said tile picture item to said tile description information, and

a communication unit configured to output said bistream together with said provided information as an encapsulated data file.

According to a sixth aspect of the invention, there is provided a device configured to implement a method according to the second aspect.

The device may be configured to process an encapsulated data file including an encoded bitstream corresponding to one or more images, and information including tile description information comprising spatial parameters for dividing an image area into one or more tiles. The device may also comprise:

a processing unit configured to select an image region of interest, identify, from said tile description information, tiles which correspond to the selected area of interest, select one or more tile picture items linked to said identified tiles, each tile picture item identifying a portion of the bitstream representing a tile of a single image, extract a portion of the bitstream identified by the selected tile picture item(s), and

a communication unit configured to output said extracted bitstream portion

According to a seventh aspect of the invention, there is provided a device configured to implement a method according to the third aspect.

The device may be configured to process image data representing at least one image for encapsulation into an encapsulation file, and the device may comprise a processing unit configured to obtain a spatial subdivision of said at least one image into a plurality of image portions, determine at least one portion identification data identifying a data portion within said image data, representing an image portion of said plurality, encapsulate said image data into said encapsulation file along with at least:

subdivision description data representing said subdivision of said at least one image, said portion identification data, and reference data linking said subdivision description data and said portion identification data.

According to an eighth aspect of the invention, there is provided a device configured to implement a method according to the fourth aspect.

The device may be configured to process an encapsulation file comprising:

image data representing at least one image, subdivision description data representing a spatial subdivision of said at least one image into a plurality of image portions,

at least one portion identification data identifying a data portion within said image data, representing an image portion of said plurality, and reference data linking said subdivision description data and said portion information.

The device may also comprise a processing unit configured to determine a region of interest in said at least one image, determine, based on said subdivision description data, at least one image portion, belonging to said region of interest, access, based on said reference data, at least one portion identification data identifying a data portion within said image data, representing said at least one image portion belonging to said region of interest, and extract said data portion within said image data.

According to a ninth aspect of the invention, there is provided a system comprising:

a first device according to the fifth of seventh aspect, and a second device according to the sixth of eighth aspect for processing files from said first device.

The invention also provides a computer program and a computer program product for carrying out any of the methods described herein and/or for embodying any of the apparatus features described herein, and a computer readable medium having stored thereon a program for carrying out any of the methods described herein and/or for embodying any of the apparatus features described herein.

The invention extends to methods, apparatus and/or use substantially as herein described with reference to the accompanying drawings.

BRIEF DESCRIPTION OF THE DRAWINGS

Other features and advantages of the invention will become apparent from the following description of non-limiting exemplary embodiments, with reference to the appended drawings:

FIG. 1 illustrates a description of a still image encoded with tiles of ISO Base Media File Format;

FIG. 2 illustrates an example of a tiled video;

FIG. 3 illustrates various tile/slice configurations in HEVC;

FIG. 4 illustrates the tile encapsulation according to the ISO Base Media File format with 'track' boxes;

FIG. 5 illustrates the standard metadata for describing information items in 'meta' boxes of the ISO BMFF;

FIG. 6 illustrates an exemplary extension to the information item description;

FIG. 7 illustrates the referencing mechanisms between information items;

FIG. 8 illustrates a context of implementation of embodiments of the invention;

FIG. 9 is a schematic block diagram of a computing device for implementation of one or more embodiments of the invention.

DETAILED DESCRIPTION OF THE INVENTION

In what follows, embodiments of the invention are described.

In order to better understand the technical context, video tiling is explained with reference to FIG. 2 which shows a video (200) having consecutive temporal frames. Each frame (201) is divided into 8 portions (here rectangular portions) referred to as "tiles" T1 to T8. The number and the

shape of the tiles can be different. In what follows, it is considered that the tiling is the same whatever the index of the video frame.

The result of this tiling is 8 independent sub-videos (**202**). These sub-videos represent a partition of the whole global video. Each independent sub-video can be encoded as an independent bitstream, according to the AVC or HEVC standards for example. The sub-video can also be part of one single video bitstream, like for example tiles of the HEVC standard or slices of the AVC standard.

The HEVC standard defines different spatial subdivision of pictures: tiles, slices and slice segments. These different subdivisions (or partitions) have been introduced for different purposes: the slices are related to streaming issues while the tiles and the slice segments have been defined for parallel processing.

A tile defines a rectangular region of a picture that contains an integer number of Coding Tree Units (CTU). FIG. 3 shows the tiling of an image (**300**) defined by row and column boundaries (**301**, **302**). This makes the tiles good candidates for regions of interest description in terms of position and size. However, the HEVC standard bitstream organization in terms of syntax and its encapsulation into Network Abstract Layer (NAL) units is rather based on slices (as in AVC standard).

According to the HEVC standard, a slice is a set of slice segments, with at least the first slice segment being an independent slice segment, the others, if any, being dependent slice segments. A slice segment contains an integer number of consecutive CTUs (in the raster scan order). It has not necessarily a rectangular shape (thus less appropriate than tiles for region of interest representation). A slice segment is encoded in the HEVC bitstream as a header called “slice_segment_header” followed by data called “slice_segment_data”. Independent slice segments and dependent slice segments differ by their header: dependent slice segments have a shorter header because they reuse information from the independent slice segment’s header. Both independent and dependent slice segments contain a list of entry points in the bitstream: either to tiles or to entropy decoding synchronization points.

FIG. 3 shows different configurations of images **310** and **320** of slice, slice segments and tiles. These configurations differ from the configuration of image **300** in which one tile has one slice (containing only one independent slice segment). Image **310** is partitioned into two vertical tiles (**311**, **312**) and one slice (with 5 slice segments). Image **320** is split into two tiles (**321**, **322**), the left tile **321** having two slices (each with two slice segments), the right tile **322** having one slice (with two slice segments). The HEVC standard defines organization rules between tiles and slice segments that can be summarized as follows (one or both conditions have to be met):

- All CTUs in a slice segment belong to the same tile, and
- All CTUs in a tile belong to the same slice segment

In order to have matching region of interest support and transport, the configuration **300**, wherein one tile contains one slice with one independent segment, is preferred. However, the encapsulation solution would work with the other configurations **310** or **320**.

While the tile is the appropriate support for regions of interest, the slice segment is the entity that will be actually put into NAL units for transport on the network and aggregated to form an access unit (coded picture or sample at file format level). According to the HEVC standard, the type of NAL unit is specified in a NAL unit header. For NAL units of type “coded slice segment”, the slice_segment_header

indicates via the “slice_segment_address” syntax element the address of the first coding tree block in the slice segment. The tiling information is provided in a PPS (Picture Parameter Set) NAL unit. The relation between a slice segment and a tile can then be deduced from these parameters.

By definition, on tiles borders, the spatial predictions are reset. However, nothing prevents a tile from using temporal predictors from a different tile in the reference frame(s). In order to build independent tiles, at encoding time, the motion vectors for the prediction units inside a tile are constrained to remain in the co-located tile in the reference frame(s). In addition, the in-loop filters (deblocking and SAO) have to be deactivated on the tiles borders so that no error drift is introduced when decoding only one tile. This control of the in-loop filters is already available in the HEVC standard and is set in slice segment headers with the flag called “loop_filter_across_tiles_enabled_flag”. By explicitly setting this flag to 0, the pixels at the tiles borders do not depend on the pixels that fall on the border of the neighbor tiles. When the two conditions on motion vectors and on in-loop filters are met, the tiles are said “independently decodable” or “independent”.

When a video sequence is encoded as a set of independent tiles, it may be decoded using a tile-based decoding from one frame to another without risking missing reference data or propagation of reconstruction errors. This configuration makes it possible to reconstruct only a spatial part of the original video that corresponds, for example, to a region of interest.

In what follows, independent tiles are considered.

With reference to FIG. 4, encapsulation of tiles into ISO BMFF file format is described. For example, each tile is encapsulated into a dedicated track. The setup and initialization information common to all tiles is encapsulated into a specific track, called for example the “tile base track”. The full video is thus encapsulated as a composition of all these tracks, namely the tile base track and the set of tile tracks.

FIG. 4 illustrates an exemplary encapsulation. One way to encapsulate tiled video according to the ISO BMFF standard is to split each tile into a dedicated track, to encapsulate the setup and initialization information common to all tiles in a specific track, called for example the “tile base track” and to encapsulate the full video as a composition of all these tracks: tile base track plus a set of tile tracks. The encapsulation is thus referred to as “multi-track tile encapsulation”. An example of multi-track tile encapsulation is provided in FIG. 4.

Box **401** represents the main ISO BMFF box ‘moov’ and contains the full list of tracks with their identifiers. For example, boxes **411** to **414** represent tile tracks (four tiles in the present example) and box **420** represents the tile base track. Additional tracks such as audio or text tracks may be used and encapsulated in the same file. However, for the sake of conciseness such additional tracks are not discussed here.

As represented in FIG. 4, the tile data is split into independent and addressable tracks so that any combination of tile track(s) can easily be reconstructed from the tile base track referencing the tile tracks for decoding and display. The tile base track may also be referred to as the “composite track” or “reference track” since it is designed to allow combination of any tiles: one, many or all tiles. The tile base track **420** contains common information to all the tile tracks and a list of samples **450** (only the first one is represented in FIG. 4) in a “mdat” box. Each sample **450** of the tile base track **420** is built by reference to each tile track through the use of extractors (**451** to **454** each one representing one

extractor to each tile). Each tile track **411** to **414** represents a spatial part of the whole, or full-frame, video. The tile description (position, size, bandwidth etc.) is stored in the track header boxes (not represented) of each tile track **411** to **414**. The tile base track and each tile track are cross-referenced (**405**) using a box “TrackReferenceBox” in each track. Each tile track **411** to **414** refers to the tile base track **420** as the ‘tbas’ track (‘tbas’ is a specific code indicating a coding dependency from each tile track to the tile base track, in particular where to find the parameter “HEVCDecoder-ConfigurationRecord” that makes it possible to setup the video decoder that will process the elementary stream resulting from the file format parsing). Conversely, in order to enable full-video reconstruction, the tile base track **420** indicates a dependency of type ‘scal’ to each tile track (**405**). This is to indicate the coding dependency and to reflect the sample **450** definition of the tile base track as extractors to the tile tracks data. These extractors are specific extractors that, at parsing time, can support the absence of data. In FIG. **4**, in order to provide a streamable version of the file, each track is decomposed into media segments (**431** to **434** for the tile tracks and **460** for the tile base track). Each media segment comprises one or more movie fragments, indicated by the ‘moov’ box plus data. For tile tracks, the data part corresponds to a spatial sub-part of the video while for the tile base track, it contains the parameter sets, SEI messages when present and the list of extractors. The “moov” box **401** in case of streaming application would fit in an initialization segment. FIG. **4** illustrates only one segment but the tracks can be decomposed into any number of segments, the constraint being that segments for tile tracks and for tile base track follow the same temporal decomposition (i.e. they are temporally aligned), this is to make switching possible from full-video to a tile or a set of tiles. The granularity of this temporal decomposition is not described here, for the sake of conciseness.

The file format has descriptive metadata (such as “VisualSampleGroupEntries” for instance, or track reference types in ‘terf’ boxes) that describe the relationships between the tracks so that the data corresponding to one tile, a combination of tiles or all the tiles can easily be identified by parsing descriptive metadata.

In what follows, still images are described at the same level. Thus, upon user selection of any tiles, combination of tiles or all tiles of a picture, identification and extraction is facilitated. In case the pictures are mixed with video data, the description comes in parallel to the descriptive metadata for the video. Thus, for the same data set, an additional indexation layer is provided for the pictures (in addition to the indexation layers for the video and for the audio). In still image file formats using ‘meta’ boxes, the pictures with the related information are described as information items. As illustrated in FIG. **5**, the information items are listed in a dedicated sub-box “ItemInfoBox” **500** of the ‘meta’ box. This sub-box provides the number of information items present in the file. The sub-box also provides for each item, descriptive metadata represented as “ItemInfoEntry” **501**. Several versions **502** (0, 1, 2) of this box exist according to the ISO BMFF standard evolution.

“Meta” items may not be stored contiguously in a file. Also, there is no particular restriction concerning the interleaving of the item data. Thus, two items in a same file may share one or several blocks of data. This is particularly useful for HEVC tiles (tiles can be stored contiguously or not), since it can make it straightforward to have one item per independently decodable tile. This item indicates the

data offset in the main HEVC picture and length of the slice(s) used for the tile through an Item Location Box.

According to embodiments, a new item type for describing a tile picture may be added, named for example: “hvct” or ‘tile’ or reused from ISO/IEC 14496-15: ‘hvt1’. Each item representing the tile picture (whatever the four character code chosen) may have a reference of type “tbas” to the ‘hvt1’ item from which it is extracted. Each item has an identifier “item_ID” **503** and is further described in a box “ItemLocationBox” in terms of byte position and size in the media data box containing the compressed data for the pictures.

Such syntax makes it possible for a file format reader (or “parser”), to determine, via the list of information items, how many information items are available with information concerning their type **504**, for example ‘tile’ to indicate an information item is a tile picture of a full picture.

Thus, it is made possible to select a subset of information items in the file, a combination thereof, or the full set of information items in order to download only one tile of the image and the associated decoder configuration, while skipping the other tiles.

For cases where an HEVC tile depends on another HEVC tile for decoding, the dependency shall be indicated by an item reference of type ‘dpnd’ (or any specific four character code that indicates coding dependencies) as described in document w14123, WD of ISO/IEC 14496-15:2013 AMD 1, “Enhanced carriage of HEVC and support of MVC with depth information”, MPEG 107 San José January 2014.

This document defines tools for associating HEVC tile NALUs with sample group descriptions indicating the spatial position of the tile (using the “TileRegionGroupEntry” descriptor). However, there is no direct equivalent of sample grouping for metadata information items which could allow reuse of these descriptors.

Therefore, according to embodiments, a tile description item is defined per tile and the tile is linked to its description using a modified version of the “ItemReferenceBox” box as explained below.

According to other embodiments, only one tiling description is provided, preferably in a generic way. Thus, the item list does not get too long.

The design may be as follows:

allow some items to describe a set of metadata, similar to sample groups but specific to each item type, for any item, add the ability to describe one parameter for a given type of item reference. The parameter would then be interpreted depending on the type of the referred item (similar to grouping type).

An upgrade of the descriptive metadata for an information item may be needed as explained in what follows with reference to FIG. **6**.

According to the ISO BMFF standard, the sample grouping mechanism is based on two main boxes having a “grouping_type” parameter as follows:

the box “SampleGroupDescriptionBox” has a parameter ‘sgpd’ that defines a list of properties (a list “SampleGroupEntry”),
the box “SampleToGroupBox” has a parameter ‘sbgp’ that defines a list of sample group with their mapping to a property.

The “grouping_type” parameter links a list of sample groups to a list of properties, the mapping of a sample group to one property in the list being specified in the box “SampleToGroupBox”.

In order to provide the same functionality for the information items, a list of information items groups and a list of

13

properties have to be described. Also, it should be made possible to map each group of information items to a property.

In what follows, there is described how to make possible such descriptive metadata to be embedded in the Still Image File Format. In other words, how to link a descriptor to an image item. Even if the use cases are described for the HEVC Still Image File Format, the following features may be used in other standards such as ISO/IEC 14496-12 for associating any kind of information item with additional descriptive metadata.

According to embodiments, the existing “ItemInformationEntry” box **601** with parameter ‘infe’ is extended with a new version number (**602** and **603**) in order to link each item to a property via a new parameter called “iref_type” **604** as shown in FIG. 6. This makes it possible to avoid the creation of new boxes and improves the description while keeping it short.

The original definition of ItemInformationEntry box is given by:

```

if (version == 2) {
    unsigned int(16) item_ID;
    unsigned int(16) item_protection_index;
    unsigned int(32) item_type;
    string item_name ;
    if (item_type=='mime') {
        string content_type;
        string content_encoding; //optional
    } else if (item_type == 'uri ') {
        string item_uri_type;
    }
}

```

A new version making linking a tile picture to its description may be as follows:

```

if ((version == 2) || (version == 3)) {
    unsigned int(16) item_ID;
    unsigned int(16) item_protection_index;
    unsigned int(32) item_type;
    string item_name;
    if (version == 2) {
        if (item_type=='mime') {
            string content_type;
            string content_encoding; //optional
        } else if (item_type == 'uri ') {
            string item_uri_type;
        }
    }
    if (version == 3) {
        unsigned int(32) item_iref_parameter_count;
        for (i=0 ; i< item_iref_parameter_count ; i++) {
            unsigned int(32) iref_type;
            unsigned int(32) iref_parameter;
        }
    }
}

```

According to other embodiments, closer to the box “SampleToGroupBox”, the definition of the box “ItemInformationBox” with four character code ‘iinfe’ is changed as follows, for example by introducing a new version of this box:

14

the current version:

```

aligned(8) class ItemInfoBox extends FullBox('iinfe', version = 0, 0) {
    unsigned int(16) entry_count;
    ItemInfoEntry[ entry_count ] item_infos;
}

```

is changed into:

```

aligned(8) class ItemInfoBox extends FullBox('iinfe', version = 1, 0) {
    unsigned int(16)group_entry_count;
    for (int g=0; g< group_entry_count;g++){
        unsigned int(16) item_run;
        unsigned int(16) grouping_type;
        unsigned int(16) property_index;
        unsigned int(16) entry_count;
        ItemInfoEntry[ entry_count ] item_infos;
    }
    unsigned int(16) remaining_entry_count;
    ItemInfoEntry[remaining_entry_count ] item_infos;
}

```

Alternatively, in order to signal whether group is in use or not, the current version is changed into:

```

aligned(8) class ItemInfoBox extends FullBox('iinfe', version = 1, 0) {
    unsigned int(1)group_is_used;
    if (group_is_used == 0){ // standard iinf box but with 1
        additional byte overhead
        unsigned int(7)reserved; // for byte alignment
        unsigned int(16) entry_count;
        ItemInfoEntry[ entry_count ] item_infos;
    } else {
        unsigned int(15)group_entry_count;
        for (int g=0; g< group_entry_count;g++){
            unsigned int(16) item_run;
            unsigned int(16) grouping_type;
            unsigned int(16) property_index;
            unsigned int(16) entry_count;
            ItemInfoEntry[ entry_count ] item_infos;
        }
        unsigned int(16) remaining_entry_count;
        ItemInfoEntry[remaining_entry_count ] item_infos;
    }
}

```

The “group_entry_count” parameter defines the number of information items groups in the media file. For each group of information item, a number of information items is indicated, starting from item_ID=0. Since information items have no time constraints and relationships, contrary to the samples, the encapsulation module can assign the information item identifiers in any order. By assigning increasing identifiers numbers following the items group, the list of information group can be more efficiently represented using a parameter item_run identifying the runs of consecutive information items identifiers in a group.

The related information items have an index called for example “property_index”. This “property_index” parameter associated with the “grouping_type” parameter enables a file format parser (or “reader”) to identify either a reference to descriptive metadata or the descriptive metadata itself. FIG. 7 illustrates two exemplary embodiments.

The group feature in box “SingleItemTypeReferenceBox” **701** may be used with a group identification “group_ID” instead of the information item identification (item_ID) that is usually used for the value of the from_item_ID parameter. By design, the box “SingleItemTypeReferenceBox” makes it easier to find all the references of a specific kind or from a specific item. Using it with a “group_ID” instead of

15

“item_ID” makes it possible to find for a group of items to easily identify all the references of a specific type. Advantageously, since there is at most one box “ItemInformationBox” per encapsulated file, there is no need to define group identifications. The encapsulation module (during encoding) and the parsing module (during decoding) can run a respective counter (as the “g” variable in the box “ItemInformationBox” on the list of information item groups as they are created or read. Alternatively, the parser may be informed, using the flag “group_used_flag”, whether to maintain or not the group identification counter.

Back to the example with one group of information items corresponding to the tile pictures, one group may contain four entries and the reference 700 “SingleItemTypeReference” may indicate the list of information items 704 on which the four tile picture information items depend, and so for a particular reference type 703.

According to other exemplary embodiments, the information item is used in a new kind of box “ItemReferenceBox”, as described hereinafter, that makes it possible, from one item 722, to list multiple reference types 723 to various other information items 724.

For the latter case, the specific box “ItemReferenceBox” 721 may be implemented as follows:

```
aligned(8) class MultipleItemTypeReferenceBox(void) extends
Box(void) {
    unsigned int(16) from_item_ID;
    unsigned int(16) reference_count;
    for (j=0; j<reference_count; j++) {
        unsigned int(32) reference_type; // new parameter to allow
        multiple types
        unsigned int(16) to_item_ID;
    }
}
```

As for the standard box “ItemInformationBox”, the list of item entries is described, but this time with a different order depending on the grouping. In the tile example, this may lead to a first group of four information items corresponding to the tile pictures gathered in a group with a parameter that may be named ‘tile’ followed by non-grouped information items for the configuration information, for the full picture information item and optionally for the EXIF metadata.

Thus, one box is modified and one box is created that is a specific kind of ItemReferenceBox. In what follows, this new kind of ItemReferenceBox is described.

The box “ItemReferenceBox” may also be extended by distinguishing between the various kinds of ItemReferenceBox by using the flag parameters in the box “FullBox” which is part of the ItemReferenceBox as follows:

```
aligned(8) class ItemReferenceBox extends FullBox('iref', 0, flags) {
switch (flags) {
case 0:
    SingleItemTypeReferenceBox references[ ];
    break;
case 1:
    MultipleItemTypeReferenceBox references[ ];
    break;
case 2:
    SharedItemTypeReferenceBox references[ ];
    break;
}
}
```

16

Using the box “MultipleItemTypeReferenceBox” 721, one picture with four tiles may be described as follows:

```
Item Reference Box (version=1 or flags=1):
fromID=2, ref_count=1, type='cdsc', toID=1;
fromID=1, ref_count=1, type='init', toID=3;
fromID=4, ref_count=2, type='tbas', toID=1, type='tile'
toID=8;
fromID=5, ref_count=2, type='tbas', toID=1, type='tile'
toID=8;
fromID=6, ref_count=2, type='tbas', toID=1, type='tile'
toID=8;
fromID=7, ref_count=2, type='tbas', toID=1, type='tile'
toID=8;
```

This design makes it fairly easier to find all the references of any kinds from a specific item.

Description support 711 for a list of items 712 referencing a same item 714 with a given type 713 may be as follows:

```
aligned(8) class SharedItemTypeReferenceBox(ref_type) extends
Box(referenceType) {
    unsigned int(16) reference_count;
    for (j=0; j<reference_count; j++) {
        unsigned int(16) from_item_ID;
    }
    unsigned int(16) to_item_ID;
}
```

In the example of a picture with four tiles, then we may have:

```
type='cdsc', ref_count=1, fromID=2, toID=1;
type='init', ref_count=1, fromID=1, toID=3;
type='tbas', ref_count=4, fromID=4, fromID=5, fromID=6, fromID=7, toID=1;
type='tile', ref_count=4, fromID=4, fromID=5, fromID=6, fromID=7, toID=8;
```

The design of the box “SharedItemTypeReferenceBox” makes it easier to find all the references of a specific type pointing to a specific item. This is in contrast with box “SingleItemTypeReferenceBox”. But since most of the “reference_type” defined for track references are not bi-directional, the box “SingleItemTypeReferenceBox” may not be used with some unidirectional reference type to signal all nodes having this reference type to other items. Alternatively, a flag may be provided in the “SingleItemTypeReference” for indicating whether it is a direct reference or a reverse reference, thereby alleviating the need for the new SharedItemTypeReferenceBox.

In view of the above, an information item can be associated with tiling information. A description of this tiling information has now to be provided.

For example, each tile may be described using a tile descriptor, such as the “iref_parameter” 605 of the extended “ItemInfoEntry” 601. A specific descriptor may be as follows:

```
aligned(8) class TileInfoDataBlock( ) {
    unsigned int(8) version;
    unsigned int(32) reference_width; // full image sizes
    unsigned int(32) reference_height;
    unsigned int(32) horizontal_offset; // tile positions
    unsigned int(32) vertical_offset;
    unsigned int(32) region_width; // tile sizes
    unsigned int(32) region_height;
}
```

According to embodiments, a descriptor may be used for the grid of tiles to apply to the one or more pictures to be stored.

Such descriptor may be as follows:

```

aligned(8) class TileInfoDataItem ( ) {
  unsigned int(8) version;
  unsigned int(1) regular_spacing; // regular grid or not
  unsigned int(7) reserved = 0;
  unsigned int(32) reference_width; // full-frame sizes
  unsigned int(32) reference_height;
  unsigned int(32) nb_cell_horiz;
  unsigned int(32) nb_cell_vert;
  if (!regular_spacing) {
    for (i=0; i<nb_cell_width; i++)
      unsigned int(16) cell_width;
    for (i=0; i<nb_cell_height; i++)
      unsigned int(16) cell_height;
  }
}

```

This descriptor “TileInfoDataItem” allows describing a tiling grid (regular or irregular). The grid is described rows by rows starting from top-left.

The descriptor shall be stored as an item of type ‘tile’. When another item refers to this item, it shall use a reference of type “tile” to this description and it shall have a parameter “iref_parameter” specified, whose value is the 0-based index of the cell in the grid defined by the descriptor, where 0 is the top-left item, 1 is the cell immediately to the right of cell 0 and so on.

In the Descriptor:

“version” indicates the version of the syntax for the TileInfoDataItem. Only value 0 is defined.

“regular_spacing” indicates if all tiles in the grid have the same width and the same height.

“reference_width, reference_height” indicates the units in which the grid is described. These units may or may not match the pixel resolution of the image which refers to this item. If the grid is regular, the “reference_width” (resp. “reference_height”) shall be a multiple of “nb_cell_horiz” (resp. “nb_cell_vert”).

“cell_width” gives the horizontal division of the grid in non-regular tiles, starting from the left.

“cell_height” gives the vertical division of the grid in non-regular tiles, starting from the top.

The above approach makes it possible to share the tiling information for all tiles.

Moreover, in case there are multiple pictures sharing the same tiling, even more description may be shared by simply referencing a cell in the grid of tiles.

The tiling configuration can be put in the media data box or in a dedicated box shared (by reference) among the tile information items.

The above descriptors are pure spatial descriptors in the sense that they only provide spatial locations and sizes for sub-image(s) in a greater image. In some use cases, for example with image collections or image composition, a spatial location is not enough to describe the image, typically when images overlap. This is one limitation of the TileInfoDataBlock descriptor above. In order to allow image composition, whatever the image i.e. a tile or an independent/complete image, it may be useful to define a descriptor that contains on the one hand the positions and sizes of the image (spatial relations) and on the other hand display information (color, cropping . . .) for that picture. For example, color information can be provided to transform a sub-image from a color space to another one for display. This kind of information can be conveyed in the ColorInformationBox ‘colr’ of the ISOBMFF. It can be useful, for

compacity, to have the same data prepared for different kinds of display just by providing the transformation parameters to apply rather than conveying the two different so-transformed pictures. As well, the pixel aspect ratio like PixelAspectRatio box ‘pasp’ defined in the ISOBMFF Part-12 can be put in this descriptor to redefine a width and height that can be different than the encoded width and height of each picture. This would indicate the scale ratio to apply by the display after the decoding of an image. We would then have the coded sizes stored in the video sample entries (‘std’ box for example) and the display sizes deduced from the ‘pasp’ box. Another possible information for display could be the clean aperture information box ‘clap’ also defined in ISOBMFF. According to standard SMPTE 274M, the clean aperture defines an area within which picture information is subjectively uncontaminated by all edge transient distortions (possible ringing effects at the borders of images after analog to digital conversions). This list of parameters useful for display is not limitative and we could put as optional components in the sub-image descriptor any other descriptive metadata box. These ones can be explicitly mentioned because they are already part of the standard and they provide generic tools to indicate image cropping, sample aspect ratio modification and color adjustments. Unfortunately their use was only possible for media tracks, not for image file format relying on ‘meta’ boxes. We then suggest a new descriptor called for example “SimpleImageMeta-Data” to support spatial description of image items, along with other properties such as clean aperture or sample aspect ratio. This applies to any sub-image (tile or independent image) intended to be composed in a bigger image or at the reverse extracted from a bigger image:

```

aligned(8) class SimpleImageMetaData {
  CleanApertureBox clap; // optional
  PixelAspectRatioBox pasp; // optional
  ColourInformationBox colour; // optional
  ImageSpatialRelationBox location; // optional
}

```

Or its variation when considering extension parameters to help the display process (through for example extra_boxes):

```

aligned(8) class SimpleImageMetaData {
  CleanApertureBox clap; // optional
  PixelAspectRatioBox pasp; // optional
  ColourInformationBox colour; // optional
  ImageSpatialRelationBox location; // optional
  extra_boxes boxes; // optional
}

```

Where the ImageSpatialRelationBox is an extension of the TileInfoDataBlock as described in the following. Another useful parameter to consider is the possibility to compose images as layers. We then suggest inserting a parameter to indicate the level associated to an image in this layered composition. This is typically useful when images overlap. This can be called ‘layer’ for example with layer information indication. An example syntax for such descriptor is provided:

Definition

Box Type: ‘isre’

Container: Simple image meta-data item (‘simd’)

Mandatory: No

Quantity: Zero or one per item

Syntax:

```

aligned(8) class ImageSpatialRelationBox
extends FullBox('isre, version = 0, 0) {
  unsigned int(32) horizontal_display_offset;
  unsigned int(32) vertical_display_offset;
  unsigned int(32) display_width;
  unsigned int(32) display_height;
  int(16) layer;
}

```

with the associated semantics:

horizontal_display_offset specifies the horizontal offset of the image.

vertical_display_offset specifies the vertical offset of the image.

display_width specifies the width of the image.

display_height specifies the height of the image.

layer specifies the front-to-back ordering of the image; images with lower numbers are closer to the viewer. 0 is the normal value, and -1 would be in front of layer 0, and so on

This new 'isre' box type gives the ability to describe the relative position of an image with other images in an image collection. It provides a subset of the functionalities of the transformation matrix usually found in the movie or track header box of a media file. Coordinates in the ImageSpatialRelationBox are expressed on a square grid giving the author's intended display size of the collection; these units may or may not match the coded size of the image. The intended display size is defined by:

Horizontally: the maximum value of (horizontal_display_offset+display_width) for all 'isre' boxes

Vertically: the maximum value of (vertical_display_offset+display_height) for all 'isre' boxes

When some images do not have any 'isre' associated while other images in the file have 'isre' associated, the default images without any 'isre' shall be treated as if their horizontal and vertical offsets are 0, their display size is the intended display size and their layer is 0.

The ImageSpatialRelationBox indicates the relative spatial position of images after any cropping or sample aspect ratio has been applied to the images. This means, when 'isre' is combined with 'pasp', etc in a SimpleImageMetaData, the image is decoded, the 'pasp', 'clap', ccolr are applied if present and then the image is moved and scaled to the offset and size declared in the 'isre' box.

This new descriptor can be used as description of an image (tile or single image) by defining an association between the item information representing the image and the item information representing the descriptor (let's give the type 'simd' for SimpleImageMetadata Definition, any reserved 4 character code would be acceptable for a mp4 parser to easily identify the kind of metadata it is currently processing). This association is done with an ItemReferenceBox and with a new reference type; 'simr' to indicate "spatial image relation". The example description below illustrates the case of a composition of 4 images where the composition itself has no associated item. Each image item is associated to a SimpleImageMetaData item through an item reference of type 'simr' and shares the DecoderConfigurationRecord information in a dedicated 'hvcC' item.

ftyp box: major-brand='hevc', compatible-brands='hevc'
meta box: (container)

handler box: hdlr='hvc1'// no primary item provided

Item Information Entries:

5 item_type='hvc1', itemID=1, item_protection_index=0

item_type='hvc1', itemID=2, item_protection_index=0

item_type='hvc1', itemID=3, item_protection_index=0

item_type='hvc1', itemID=4, item_protection_index=0

10 item_type='simd' itemID=5 (sub-image descriptor)

item_type='simd' itemID=6 (sub-image descriptor)

item_type='simd' itemID=7 (sub-image descriptor)

item_type='simd' itemID=8 (sub-image descriptor)

15 item_type='hvcC', item_ID=9, item_protection_index=0 . . .

Item Reference:

type='simr' fromID=1, toID=5

type='simr' fromID=2, toID=6

type='simr' fromID=3, toID=7

20 type='simr' fromID=4, toID=8

type='init', fromID=1, toID=9;

type='init', fromID=3, toID=9;

type='init', fromID=4, toID=9;

type='init', fromID=5, toID=9;

25 Item Location:

itemID=1, extent_count=1, extent_offset=P1,
extent_length=L1;

itemID=2, extent_count=1, extent_offset=P2,
extent_length=L2;

30 itemID=3, extent_count=1, extent_offset=P3,
extent_length=L3;

itemID=4, extent_count=1, extent_offset=P4,
extent_length=L4;

35 itemID=5, extent_count=1, extent_offset=P5,
extent_length=L5;

itemID=6, extent_count=1, extent_offset=P6,
extent_length=L6;

40 itemID=7, extent_count=1, extent_offset=P7,
extent_length=L7;

itemID=8, extent_count=1, extent_offset=P8,
extent_length=L8;

45 itemID=9, extent_count=1, extent_offset=P0,
extent_length=L0;

Media Data Box:

1 HEVC Decoder Configuration Record ('hvcC' at offset P0)

4 HEVC Images (at file offsets P1, P2, P3, P4)

4 simple image metadata (at file offsets P5, P6, P7, P8)

50 The above organization of data is provided as an example: image and metadata could be interlaced in the media data box for example to have an image plus its metadata addressable as a single byte range. When receiving this description, a parser is informed, by parsing the informations in the 'simd' items whether a sub-image is cropped from a full picture, or conversely if a full picture is a composition from sub-images. In case of crop, the full picture item and the cropped image would share the same data range as in example below and the same decoder configuration information. The sub-image would then then be associated to a 'simd' item having only 'clap' information and no positioning, then no 'isre'.

65 In case of composition: in such case, the full picture item is associated to a 'simd' item that only contains 'isre' information and the sub-image would be associated to a 'simd' item reflecting its position in the full image.

21

The example below illustrates the case where 4 images are composed into a larger one. All images, including the composed one are exposed as a playable item using the proposed descriptor.

```

ftyp box: major-brand='hevc', compatible-brands='hevc' 5
meta box: (container)
  handler box: hdlr='hvc1' primary item: itemID=1;
Item Information Entries:
item_type='hvc1', itemID=1, item_protection_
  index=0 . . . // full-image 10
item_type='hvc1', itemID=2, item_protection_
  index=0 . . . // sub-image
item_type='hvc1', itemID=3, item_protection_
  index=0 . . . // sub-image
item_type='hvc1', itemID=4, item_protection_ 15
  index=0 . . . // sub-image
item_type='hvc1', itemID=5, item_protection_
  index=0 . . . // sub-image
item_type='simd' itemID=6 (sub-image descriptor) . . . 20
item_type='simd' itemID=7 (sub-image descriptor) . . .
item_type='simd' itemID=8 (sub-image descriptor) . . .
item_type='simd' itemID=9 (sub-image descriptor) . . .
item_type='hvcC', item_ID=10 (decoder config record)
item_type='simd', item_ID=11 (sub-image descriptor) 25
Item Reference Entries:
type='simr', fromID=1, toID=11
type='simr', fromID=2, toID=6
type='simr', fromID=3, toID=7
type='simr', fromID=4, toID=8
type='simr', fromID=5, toID=9
type='init', fromID=1, toID=10 . . .
type='init', fromID=2, toID=10 . . .
type='init', fromID=3, toID=10 . . .
type='init', fromID=4, toID=10 . . .
type='init', fromID=5, toID=10 . . .
Item Location:
itemID=1, extent_count=4, // full image is composed of 4
  sub-images
  extent_offset=P2, extent_length=L2;
  extent_offset=P3, extent_length=L3;
  extent_offset=P4, extent_length=L4;
  extent_offset=P5, extent_length=L5;
itemID=2, extent_count=1, extent_offset=P2,
  extent_length=L2;
itemID=3, extent_count=1, extent_offset=P3,
  extent_length=L3;
itemID=4, extent_count=1, extent_offset=P4,
  extent_length=L4;
itemID=5, extent_count=1, extent_offset=P5, 50
  extent_length=L5;
itemID=6, extent_count=1, extent_offset=P6,
  extent_length=L6;
itemID=7, extent_count=1, extent_offset=P7,
  extent_length=L7;
itemID=8, extent_count=1, extent_offset=P8,
  extent_length=L8;
itemID=9, extent_count=1, extent_offset=P9,
  extent_length=L9;
itemID=10, extent_count=1, extent_offset=P0, 60
  extent_length=L0;
itemID=11, extent_count=1, extent_offset=P10,
  extent_length=L10;
Media Data Box:
1 HEVC Decoder Configuration Record ('hvcC' at offset 65
  P0)
4 HEVC (sub) Images (at file offsets P2, P3, P4, P5)

```

22

5 simple image metadata (at file offsets P6, P7, P8, P9, P10)

This other example illustrates the case where the full picture is actually a tiled HEVC picture (4 tiles):

```

ftyp box: major-brand='hevc', compatible-brands='hevc'
meta box: (container)
  handler box: hdlr='hvc1' primary item: itemID=1;
Item Information Entries:
item_type='hvc1', itemID=1, item_protection_
  index=0 . . . //full-image
item_type='hvt1', itemID=2, item_protection_
  index=0 . . . // sub-image
item_type='hvt1', itemID=3, item_protection_
  index=0 . . . // sub-image
item_type='hvt1', itemID=4, item_protection_
  index=0 . . . // sub-image
item_type='hvt1', itemID=5, item_protection_
  index=0 . . . // sub-image
item_type='simd' itemID=6 (sub-image descriptor) . . .
item_type='simd' itemID=7 (sub-image descriptor) . . .
item_type='simd' itemID=8 (sub-image descriptor) . . .
item_type='simd' itemID=9 (sub-image descriptor) . . .
item_type='hvcC', item_ID=10 (decoder config record)
Item Reference Entries:
type='init', fromID=1, toID=10 . . .
// declare sub-images as tiles of the full image
type='tbas', fromID=2, toID=1 . . .
type='tbas', fromID=3, toID=1 . . .
type='tbas', fromID=4, toID=1 . . .
type='tbas', fromID=5, toID=1 . . .
// providing positions and sizes
type='simr', fromID=2, toID=6
type='simr', fromID=3, toID=7
type='simr', fromID=4, toID=8
type='simr', fromID=5, toID=9
Item Location:
itemID=1, extent_count=4, // full image is composed of 4
  tiles
  extent_offset=P2, extent_length=L2 . . . // data for tile
  1
  extent_offset=P3, extent_length=L3 . . . // data for tile
  2
  extent_offset=P4, extent_length=L4 . . . // data for tile
  3
  extent_offset=P5, extent_length=L5 . . . // data for tile
  4
itemID=2, extent_count=1, extent_offset=P2,
  extent_length=L2;
itemID=3, extent_count=1, extent_offset=P3,
  extent_length=L3;
itemID=4, extent_count=1, extent_offset=P4,
  extent_length=L4;
itemID=5, extent_count=1, extent_offset=P5,
  extent_length=L5;
itemID=6, extent_count=1, extent_offset=P6,
  extent_length=L6;
itemID=7, extent_count=1, extent_offset=P7,
  extent_length=L7;
itemID=8, extent_count=1, extent_offset=P8,
  extent_length=L8;
itemID=9, extent_count=1, extent_offset=P9,
  extent_length=L9;
itemID=10, extent_count=1, extent_offset=P0,
  extent_length=L0;

```

Media Data Box:

1 HEVC Decoder Configuration Record ('hvcC' at offset P0)

1 HEVC Image (with 4 tiles at file offsets P2, P3, P4, P5)

4 simple image metadata (at file offsets P6, P7, P8, P9)

Depending on use cases, it would be possible to have several image items sharing the same metadata, for example when the same cropping is to be applied to all images. It is also possible for an image item to have multiple 'simr' references to different SimpleImageMetaData, for example when cropping is shared among images but not spatial information.

An alternative embodiment to the new version of the ItemInfoEntry (as illustrated in FIG. 6) is to define more than one parameter (605) per information item entry and reference. In the embodiment of FIG. 6, the iref_parameter is a four bytes code that is useful in case of a tile index to refer to a cell in a tiling grid. But in order to have richer description and to be able to embed linked description inside the item info entry itself rather than with the data (in mdat box), the following extension can be useful:

```

if (version == 3) {
    unsigned int(32) item_iref_parameter_count;
    for (i=0 ; i< item_iref_parameter_count ; i++) {
        unsigned int(32) iref_type;
        ItemReferenceParameterEntry parameter;
    }
    aligned(8) abstract class ItemReferenceParameterEntry (unsigned
int(32) format)
        extends Box(format){
    }
    // Example to reference a tile index
    aligned(8) abstract class TileIndexItemReferenceParameterEntry
        extends ItemReferenceParameterEntry('tile'){
        unsigned int(32) tile_index;
    }
    // Example to inline the tile description
    aligned(8) abstract class TileIndexItemReferenceParameterEntry
        extends ItemReferenceParameterEntry('tile'){
        unsigned int(32) tile_index;
    }
}

```

In the above extension:

item_iref_parameter_count gives the number of reference types for which a parameter is given. This is unchanged compared to item 605 in FIG. 6,

iref_type gives the reference type, as indicated in the 'iref' box, for which the parameter applies for this item.

This is unchanged compared to item 605 in FIG. 6.

parameter here differs from iref_parameter (item 605 in FIG. 6) because it provides an extension means via the new box Item ReferenceParameterEntry. By specializing this new box (as done above with TileIndexItemReferenceParameterEntry for tile index in a tiling configuration), any kind of additional metadata can be associated with an information item entry provided that the encapsulation and the parsing modules are aware of the structure of this specialized box. This can be done by standard types of Item ReferenceParameterEntry or by providing by construction or in a negotiation step the structure of the parameter entry. The semantics of the parameter is given by the semantics of the item with type iref_type.

In what follows, there are provided exemplary descriptive metadata for information items describing a picture with 4 tiles and the EXIF meta data of the full picture.

In the prior art, the tile pictures were listed as information items without any corresponding description provided as

show herein below. Moreover, the setup information denoted 'hvcC' type was not described as an item. This makes it possible to factorize the common data related to HEVC parameter sets and SEI messages that apply to all tile pictures and to the full picture.

ftyp box: major-brand='hevc', compatible-brands='hevc'
meta box: (container)

handler box: hdlr='hvc1' primary item: itemID=1;

Item Information:

item_type='hvc1', itemID=1, item_protection_index=0
(unused)=> Full pict.

item_type='Exif', itemID=2, item_protection_index=0
(unused)

item_type='hvcC', itemID=3, item_protection_index=0
(unused)

item_type='hvct', itemID=4, item_protection_index=0
(unused)=> Tile pict.

item_type='hvct', itemID=5, item_protection_index=0
(unused)=> Tile pict.

item_type='hvct', itemID=6, item_protection_index=0
(unused)=> Tile pict.

item_type='hvct', itemID=7, item_protection_index=0
(unused)=> Tile pict.

Item Location:

itemID=1, extent_count=1, extent_offset=X,
extent_length=Y;

itemID=2, extent_count=1, extent_offset=P,
extent_length=Q;

itemID=3, extent_count=1, extent_offset=R,
extent_length=S;

itemID=4, extent_count=1, extent_offset=X,
extent_length=ET1;

itemID=5, extent_count=1, extent_offset=X+ET1,
extent_length=ET2;

itemID=6, extent_count=1, extent_offset=X+ET2,
extent_length=ET3;

itemID=7, extent_count=1, extent_offset=X+ET3,
extent_length=ET4;

Item Reference:

type='cdsc', fromID=2, toID=1;

type='init', fromID=1, toID=3;

type='tbas', fromID=4, toID=1;

type='tbas', fromID=5, toID=1;

type='tbas', fromID=6, toID=1;

type='tbas', fromID=7, toID=1;

Media data box:

HEVC Image (at file offset X, with length Y)

Exif data block (at file offset P, with length Q)

HEVC Config Record (at file offset R, with length S)

// No Tile description

According to embodiments, using the extension with version 3 (see FIG. 6, 602, 603) of ItemInfoEntry box (601): tile picture information is listed with associated references to parts of the tiling configuration that is also described as an information item (ID=8).

ftyp box: major-brand='hevc', compatible-brands='hevc'
meta box: (container)

handler box: hdlr='hvc1' primary item: itemID=1;

Item Information:

item_type='hvc1', itemID=1, item_protection_index=0
(unused)

item_type='Exif', itemID=2, item_protection_index=0
(unused)

item_type='hvcC', itemID=3, item_protection_index=0
(unused)

item_type='hvct', itemID=4, parameter for
ireftype==tile: tile_index=0

25

item_type='hvct', itemID=5, parameter for
 ireftype==tile: tile_index=1
 item_type='hvct', itemID=6, parameter for
 ireftype==tile: tile_index=2
 item_type='hvct', itemID=7, parameter for
 ireftype==tile: tile_index=3
 item_type='tile', itemID=8, (tiling configuration)

Item Location:

itemID=1, extent_count=1, extent_offset=X,
 extent_length=Y;

itemID=2, extent_count=1, extent_offset=P,
 extent_length=Q;

itemID=3, extent_count=1, extent_offset=R,
 extent_length=S;

itemID=4, extent_count=1, extent_offset=X,
 extent_length=ET1;

itemID=5, extent_count=1, extent_offset=X+ET1,
 extent_length=ET2;

itemID=6, extent_count=1, extent_offset=X+ET2,
 extent_length=ET3;

itemID=7, extent_count=1, extent_offset=X+ET3,
 extent_length=ET4;

itemID=8, extent_count=1, extent_offset=i,
 extent_length=I;

Item Reference:

type='cdsc', fromID=2, toID=1;

type='init', fromID=1, toID=3;

type='tbas', fromID=4, toID=1;

type='tbas', fromID=5, toID=1;

type='tbas', fromID=6, toID=1;

type='tbas', fromID=7, toID=1;

type='tile', fromID=4, toID=8; //

type='tile', fromID=5, toID=8; // link each tile pict.

type='tile', fromID=6, toID=8; // to the tiling config item

type='tile', fromID=7, toID=8; //

Media data box:

HEVC Image (at file offset X, with length Y)

Exif data block (at file offset P, with length Q)

HEVC Config Record (at file offset R, with length S)

Tile description data block (at file offset i, with length I)

FIG. 8 illustrates a context of implementation of embodiments of the invention. First different media are recorded: for example audio during step 800a, video during step 800b and one or more pictures during step 800c. Each medium is compressed during respective steps 801a, 801b and 801c. During these compression steps elementary streams 802a, 802b and 802c are generated. Next, at application level (user selection from graphical user interface; configuration of the multimedia generation system etc.), an encapsulation mode is selected in order to determine whether or not all these elementary streams should be merged or not. When the "merge" mode is activated (test 803, "yes"), data for audio, video and still images are encapsulated in the same file during step 806c as described hereinabove. If the "merge" mode is not activated (test 803, "no"), then two encapsulated files are generated during steps 806a and 806b consecutively or in parallel thereby respectively leading to the creation of one file for synchronized time media data during step 807a and an additional file with only the still images 907b. During step 806a, audio and video elementary streams are encapsulated according to the ISO/BMFF standard and the still pictures are encapsulated during step 806b as described herein above in order to provide tile description and region of interest features. Finally, a media presentation 807 is obtained and can be provided to a DASH generator to prepare it for streaming (step 820a) or stored into a memory (step 820b) or rendered on a display unit (step 820c) or

26

transmitted (step 820d) to a remote entity either entirely or after some parts (such as tiles), have been extracted by parsing the descriptive metadata.

FIG. 9 is a schematic block diagram of a computing device 900 for implementation of one or more embodiments of the invention. The computing device 900 may be a device such as a micro-computer, a workstation or a light portable device. The computing device 900 comprises a communication bus connected to:

a central processing unit 901, such as a microprocessor, denoted CPU;

a random access memory 902, denoted RAM, for storing the executable code of the method of embodiments of the invention as well as the registers adapted to record variables and parameters necessary for implementing the method for reading and writing the manifests and/or for encoding the video and/or for reading or generating the Data under a given file format, the memory capacity thereof can be expanded by an optional RAM connected to an expansion port for example;

a read only memory 903, denoted ROM, for storing computer programs for implementing embodiments of the invention;

a network interface 904 is typically connected to a communication network over which digital data to be processed are transmitted or received. The network interface 904 can be a single network interface, or composed of a set of different network interfaces (for instance wired and wireless interfaces, or different kinds of wired or wireless interfaces). Data are written to the network interface for transmission or are read from the network interface for reception under the control of the software application running in the CPU 901;

a user interface 905 for receiving inputs from a user or to display information to a user;

a hard disk 906 denoted HD

an I/O module 907 for receiving/sending data from/to external devices such as a video source or display

The executable code may be stored either in read only memory 903, on the hard disk 906 or on a removable digital medium such as for example a disk. According to a variant, the executable code of the programs can be received by means of a communication network, via the network interface 904, in order to be stored in one of the storage means of the communication device 900, such as the hard disk 906, before being executed.

The central processing unit 901 is adapted to control and direct the execution of the instructions or portions of software code of the program or programs according to embodiments of the invention, which instructions are stored in one of the aforementioned storage means. After powering on, the CPU 901 is capable of executing instructions from main RAM memory 902 relating to a software application after those instructions have been loaded from the program ROM 903 or the hard-disc (HD) 906 for example. Such a software application, when executed by the CPU 901, causes the steps of a method according to embodiments to be performed.

Alternatively, the present invention may be implemented in hardware (for example, in the form of an Application Specific Integrated Circuit or ASIC).

The present invention may be embedded in a device like a camera, a smartphone or a tablet that acts as a remote controller for a TV, for example to zoom in onto a particular region of interest. It can also be used from the same devices to have personalized browsing experience of the TV program by selecting specific areas of interest. Another usage

from these devices by a user is to share with other connected devices some selected sub-parts of his preferred videos. It can also be used in smartphone or tablet to monitor what happened in a specific area of a building put under surveillance provided that the surveillance camera supports the generation part of this invention.

While the invention has been illustrated and described in detail in the drawings and foregoing description, such illustration and description are to be considered illustrative or exemplary and not restrictive, the invention being not restricted to the disclosed embodiment. Other variations to the disclosed embodiment can be understood and effected by those skilled in the art in practicing the claimed invention, from a study of the drawings, the disclosure and the appended claims.

In the claims, the word “comprising” does not exclude other elements or steps, and the indefinite article “a” or “an” does not exclude a plurality. A single processor or other unit may fulfil the functions of several items recited in the claims. The mere fact that different features are recited in mutually different dependent claims does not indicate that a combination of these features cannot be advantageously used. Any reference signs in the claims should not be construed as limiting the scope of the invention.

The invention claimed is:

1. A method of generating a still image file including a media data portion and a metadata portion, the metadata portion being different from the media data portion, the method comprising:

obtaining identification information for each of media items, a first media item corresponding to a still image and a plurality of second media items corresponding to a plurality of partial areas in the still image;

obtaining description information comprising parameters relating to the plurality of partial areas;

obtaining association information for associating each identification information of the plurality of second media items with at least one parameter in the description information,

obtaining item reference information which represents, by using the identification information, a reference between the first media item and the plurality of second media items, and

generating the still image file including the identification information, the description information, the association information, and the item reference information in a ‘meta’ box of the metadata portion, and data of the plurality of partial areas of the still image in the media data portion.

2. The method according to claim 1, wherein the item reference information includes reference type information.

3. The method according to claim 1, wherein the identification information is stored in ‘ItemInfoBox’ of the ‘meta’ box, and the ‘meta’ box and ‘ItemInfoBox’ are defined in ISO Base Media File Format standard.

4. The method according to claim 1, wherein the item reference information is stored in ‘ItemReferenceBox’ in the ‘meta’ box, and ‘ItemReferenceBox’ is defined in ISO Base Media File Format standard.

5. The method according to claim 1, wherein the parameters includes at least one of a width and a height, color information, and decoder configuration information of the corresponding partial area.

6. The method according to claim 1, wherein the parameters include a width and a height of a partial area covered by the corresponding partial areas.

7. The method according to claim 1, wherein the parameters include a number of columns and a number of rows of a grid composed of the plurality of partial areas.

8. The method according to claim 1, wherein the item reference information represents a reference from the first media items to the plurality of second media items.

9. A method of processing a still image file including a media data portion and a metadata portion, the metadata portion being different from the media data portion, the method comprising:

obtaining, from the still image file, identification information for each of media items, a first media item corresponding to a still image and a plurality of second media items corresponding to a plurality of partial areas in the still image;

obtaining, from the still image file, description information comprising parameters relating to the plurality of partial areas;

obtaining, from the still image file, association information for associating each identification information of the plurality of second media items with at least one parameter in the description information, and

obtaining, from the still image file, item reference information which represents, by using the identification information, a reference between the first media item and the plurality of second media items, and

processing the still image file based on at least one of the identification information, the description information, the association information, and the item reference information.

10. The method according to claim 9, wherein the item reference information includes reference type information.

11. The method according to claim 9, wherein the identification information is stored in ‘ItemInfoBox’ of the ‘meta’ box, and the ‘meta’ box and ‘ItemInfoBox’ are defined in ISO Base Media File Format standard.

12. The method according to claim 9, wherein the item reference information is stored in ‘ItemReferenceBox’ in the ‘meta’ box, and ‘ItemReferenceBox’ is defined in ISO Base Media File Format standard.

13. The method according to claim 9, wherein the parameters includes at least one of a width and a height, color information, and decoder configuration information of the corresponding partial area.

14. The method according to claim 6, wherein the parameters include a width and a height of a partial area covered by the corresponding partial area.

15. The method according to claim 9, wherein the parameters include a number of columns and a number of rows of a grid composed of the plurality of partial areas.

16. The method according to claim 9, wherein the item reference information represents a reference from the first media items to the plurality of second media items.

17. A processing apparatus for generating a still image file including a media data portion and a metadata portion, the metadata portion being different from the media data portion, the processing apparatus comprising:

at least one processor; and

at least one memory storing executable instructions which, when executed by the at least one processor, cause the processing apparatus to perform operations including:

obtaining identification information for each of media items, a first media item corresponding to a still image and a plurality of second media items corresponding to a plurality of partial areas in the still image;

obtaining description information comprising parameters relating to the plurality of partial areas;
 obtaining association information for associating each identification information of the plurality of second media items with at least one parameter in the description information, and
 obtaining item reference information which represents, by using the identification information, a reference between the first media item and the plurality of second media items, and
 generating the still image file including the identification information, the description information, the association information, and the item reference information in a 'meta' box of the metadata portion, and data of the plurality of partial areas of the still image in the media data portion.

18. The processing apparatus of claim 17, wherein the item reference information includes reference type information.

19. The processing apparatus of claim 17, wherein the identification information is stored in 'ItemInfoBox' of the 'meta' box, and the 'meta' box and 'ItemInfoBox' are defined in ISO Base Media File Format standard.

20. The processing apparatus of claim 17, wherein the obtained item reference information is stored in 'ItemReferenceBox' in the 'meta' box, and 'ItemReferenceBox' is defined in ISO Base Media File Format standard.

21. The processing apparatus of claim 17, wherein the parameters includes at least one of a width and a height, color information, and decoder configuration information of the corresponding partial area.

22. A processing apparatus for processing a still image file including a media data portion and a metadata portion, the metadata portion being different from the media data portion, the processing apparatus comprising:

at least one processor; and

at least one memory storing executable instructions which, when executed by the at least one processor, cause the processing apparatus to perform operations including:

obtaining, from the still image file, identification information for each of media items, a first media item corresponding to a still image and a plurality of second media items corresponding to a plurality of partial areas in the still image;

obtaining, from the still image file, description information comprising parameters relating to the plurality of partial areas;

obtaining, from the still image file, association information for associating each identification information of the plurality of second media items with at least one parameter in the description information, and

obtaining, from the still image file, item reference information which represents, by using the identification information, a reference between the first media item and the plurality of second media items; and

processing the still image file based on at least one of the identification information, the description information, the association information, and the item reference information.

23. The processing apparatus of claim 22, wherein the item reference information includes reference type information.

24. The processing apparatus of claim 22, wherein the identification information is stored in 'ItemInfoBox' of the

'meta' box, and the 'meta' box and 'ItemInfoBox' are defined in ISO Base Media File Format standard.

25. The processing apparatus of claim 22, wherein the item reference information is stored in 'ItemReferenceBox' in the 'meta' box, and 'ItemReferenceBox' is defined in ISO Base Media File Format standard.

26. The processing apparatus of claim 22, wherein the parameters includes at least one of a width and a height, color information, and decoder configuration information of the corresponding partial area.

27. A non-transitory computer-readable storage medium storing computer executable instructions for causing a computer to execute a method of generating a still image file including a media data portion and a metadata portion, the metadata portion being different from the media data portion, the method comprising:

obtaining identification information for each of media items, a first media item corresponding to a still image and a plurality of second media items corresponding to a plurality of partial areas in the still image;

obtaining description information comprising parameters relating to the plurality of partial areas;

obtaining association information for associating each identification information of the plurality of second media items with at least one parameter in the description information, and

obtaining item reference information which represents, by using the obtained identification information, a reference between the first media item and the plurality of second media items; and

generating the still image file including the identification information, the description information, the association information, and the item reference information in a 'meta' box of the metadata portion, and data of the plurality of partial areas of the still image in the media data portion.

28. A non-transitory computer-readable storage medium storing computer executable instructions for causing a computer to execute a method of processing a still image file including a media data portion and a metadata portion, the metadata portion being different from the media data portion, the method comprising:

obtaining, from the still image file, identification information for each of media items, first media item being corresponding to a still image and a plurality of second media items being corresponding to a plurality of partial areas in the still image;

obtaining, from the still image file, description information comprising parameters relating to the plurality of partial areas;

obtaining, from the still image file, association information for associating each identification information of the plurality of second media items with at least one parameter in the description information, and

obtaining, from the still image file, item reference information which represents, by using the identification information, a reference between the first media item and the plurality of second media items; and

processing the still image file based on at least one of the identification information, the description information, the association information, and the item reference information.