



US011955849B2

(12) **United States Patent**
Campbell et al.

(10) **Patent No.:** **US 11,955,849 B2**
(45) **Date of Patent:** **Apr. 9, 2024**

(54) **COMPOSITES AND METHODS OF MAKING COMPOSITE MATERIALS**

H02K 3/52 (2006.01)
H02K 15/00 (2006.01)

(71) Applicant: **Hamilton Sundstrand Corporation**,
Charlotte, NC (US)

(52) **U.S. Cl.**
CPC *H02K 15/0018* (2013.01); *H02K 3/487*
(2013.01); *H02K 3/527* (2013.01)

(72) Inventors: **Kris H. Campbell**, Poplar Grove, IL (US); **Shin Katsumata**, Rockford, IL (US); **Brian C. Konopa**, Rockford, IL (US); **Erika M. Danckers**, Rockford, IL (US); **Andreas C. Koenig**, Rockford, IL (US); **Ashutosh Joshi**, Roscoe, IL (US)

(58) **Field of Classification Search**
CPC H02K 3/24; H02K 3/527; H02K 9/223;
H02K 9/227; H02K 2205/12; H02K
15/0018; H02K 3/487
See application file for complete search history.

(73) Assignee: **Hamilton Sundstrand Corporation**,
Charlotte, NC (US)

(56) **References Cited**

(*) Notice: Subject to any disclaimer, the term of this patent is extended or adjusted under 35 U.S.C. 154(b) by 0 days.

U.S. PATENT DOCUMENTS

(21) Appl. No.: **18/089,562**

- 5,811,908 A * 9/1998 Iwata F02N 3/02
310/156.08
- 7,821,171 B2 * 10/2010 Lemmers, Jr. H02K 3/527
310/260
- 2005/0231058 A1 * 10/2005 Down H02K 3/527
310/192
- 2015/0028709 A1 * 1/2015 Ueda H02K 1/278
310/156.19
- 2018/0278112 A1 * 9/2018 Patel H02K 3/20

(22) Filed: **Dec. 27, 2022**

* cited by examiner

(65) **Prior Publication Data**

US 2023/0170770 A1 Jun. 1, 2023

Primary Examiner — Leda T Pham

Related U.S. Application Data

(62) Division of application No. 17/142,189, filed on Jan. 5, 2021, now Pat. No. 11,539,273.

(57) **ABSTRACT**

A wedge for use in an electric machine includes a central portion comprising at least a first material, a first wing integrally attached to the central portion, and a second wing integrally attached to the central portion opposite the first wing, wherein the first wing, and the second wing include a second material.

(51) **Int. Cl.**

H02K 3/48 (2006.01)
H02K 3/487 (2006.01)

16 Claims, 3 Drawing Sheets

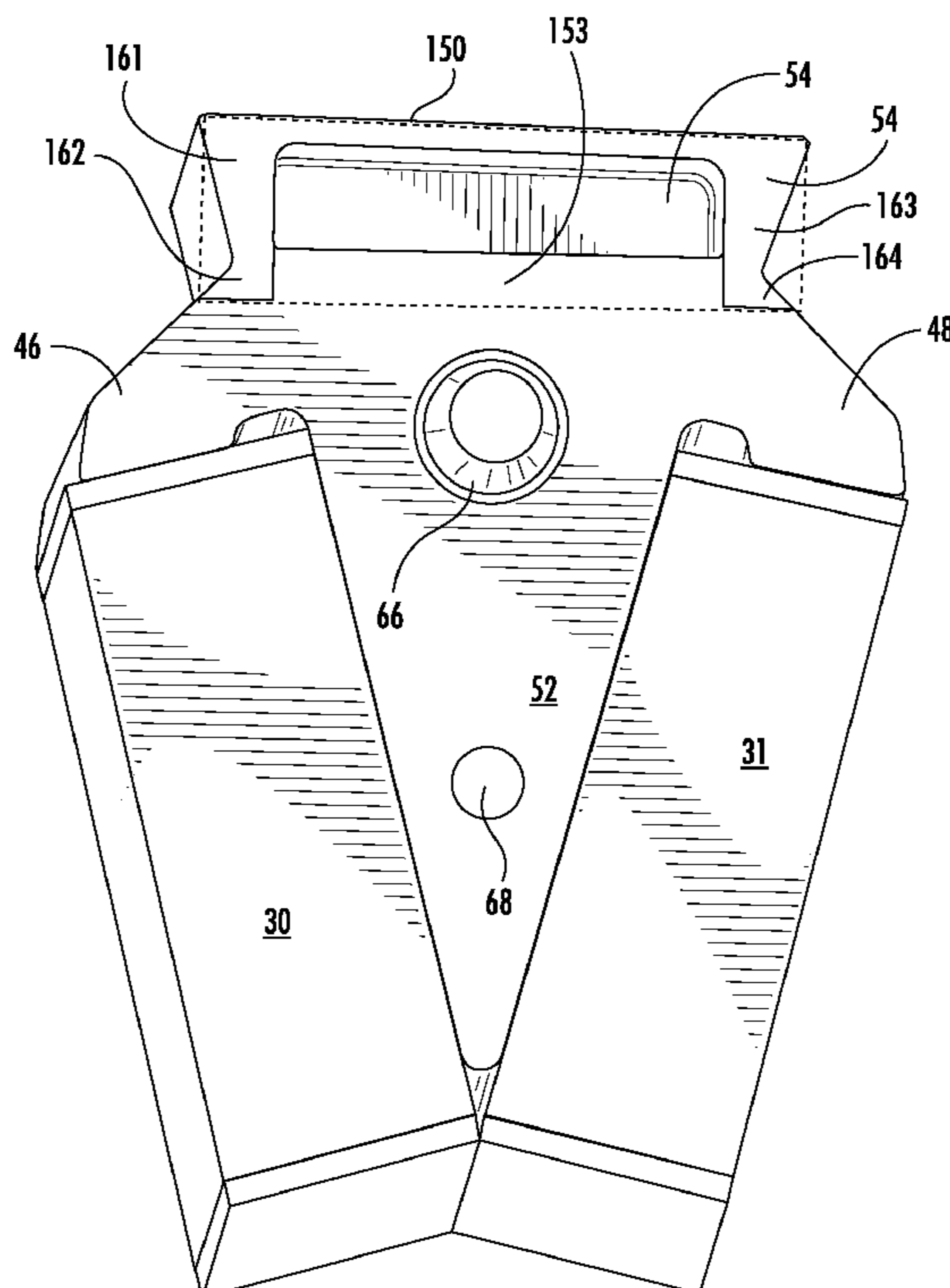

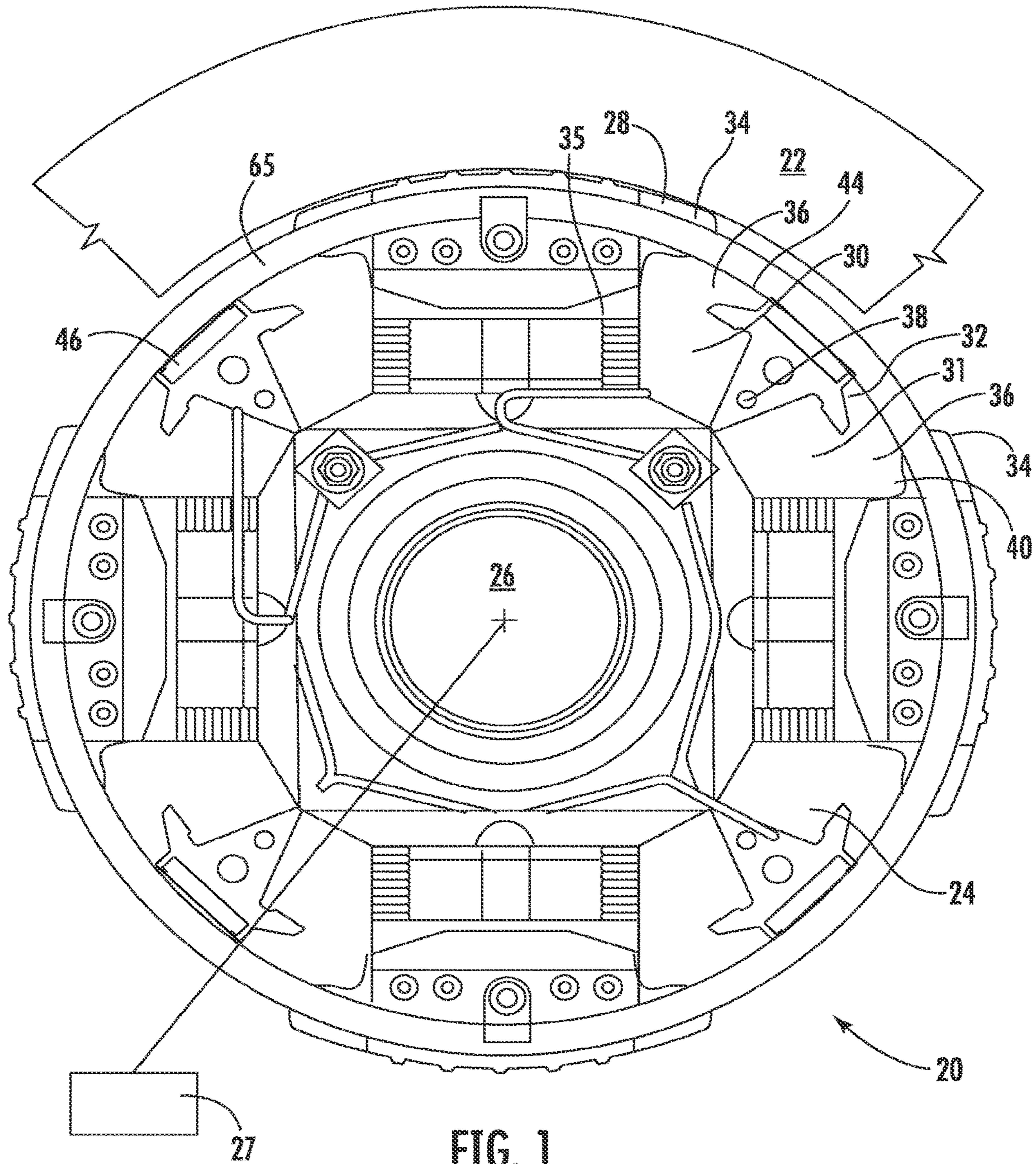

FIG. 1

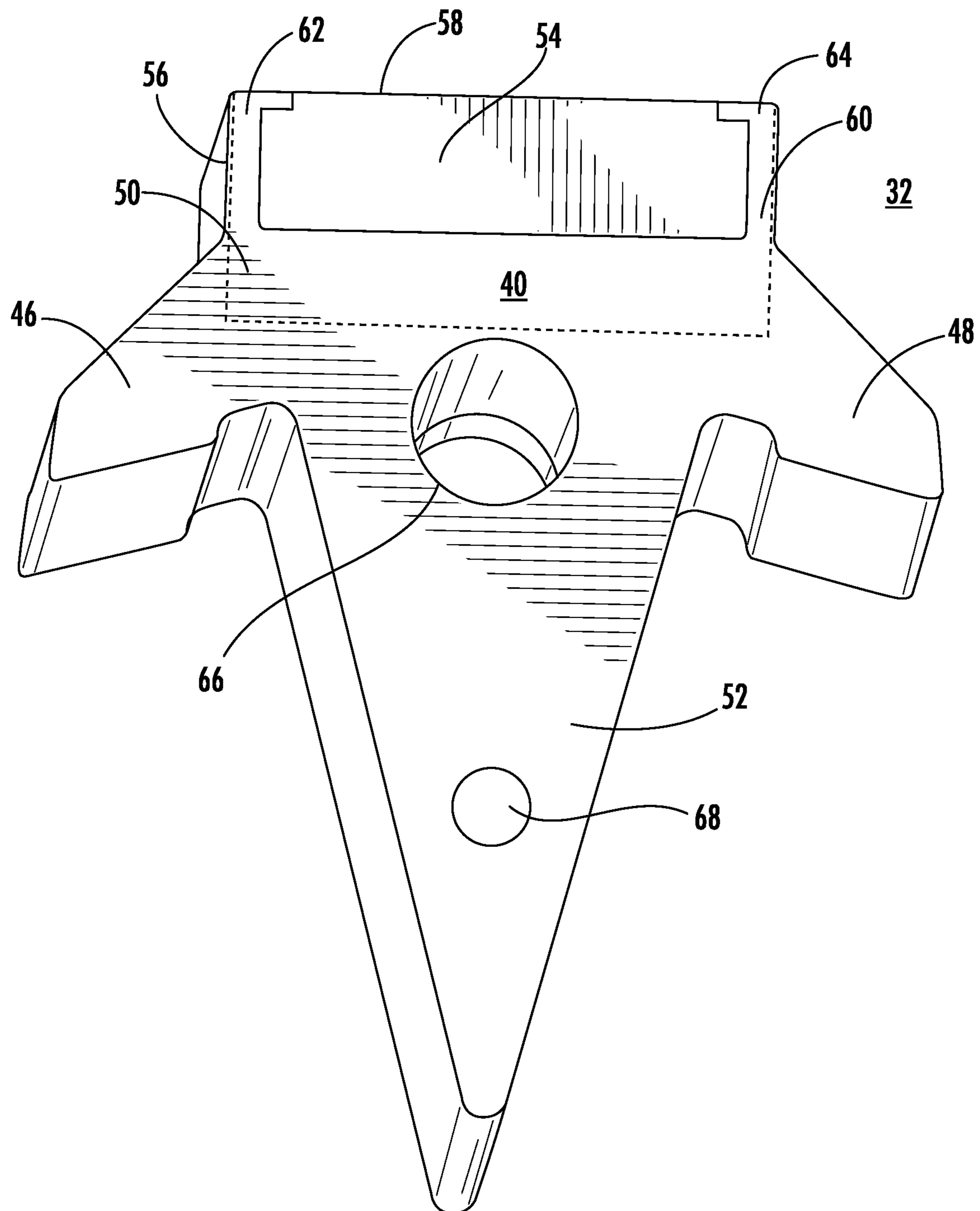

FIG. 2

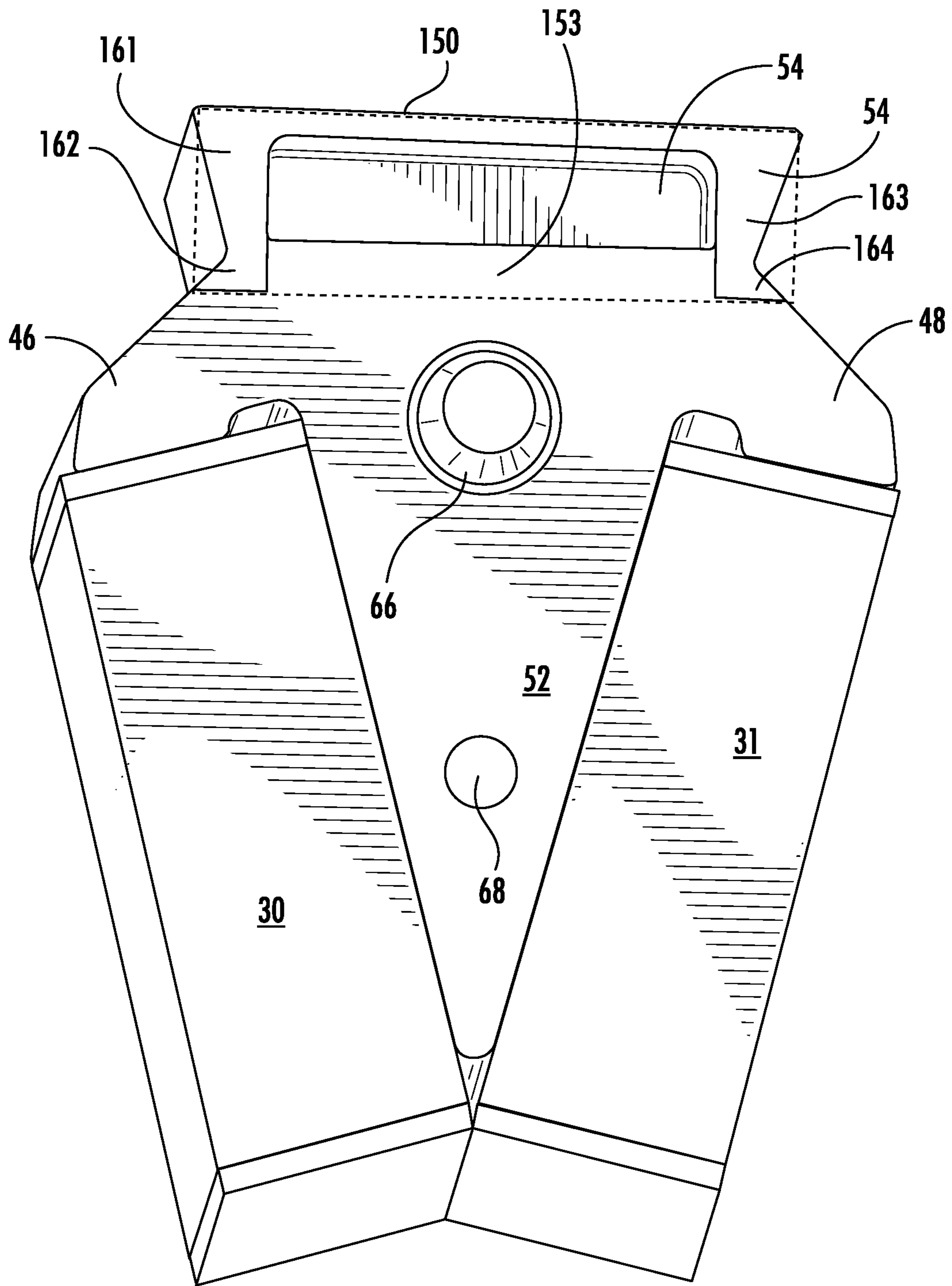

FIG. 3

1

COMPOSITES AND METHODS OF MAKING COMPOSITE MATERIALS

CROSS REFERENCE TO RELATED APPLICATIONS

This application is a divisional of U.S. patent application Ser. No. 17/142,189, filed Jan. 5, 2021, the entire content of which is incorporated herein by reference.

BACKGROUND

Technological Field

The present disclosure relates generally a wedge to be positioned between coils in an electrical generator, and more specifically to a wedge including a plurality of materials.

Description of Related Art

Electrical generators typically include a shaft that is driven for rotation, and which carries a plurality of field coils. The coils are typically separated by wedges. Wedges on electromagnetic machines are typically electrically conductive and thus have associated losses due to eddy currents. Wedges can be used smooth the area between laminations, thereby reducing friction and windage losses, however historically this has increased eddy current losses. Thus one loss cannot be reduced without increasing the other. Historically wedges have been generally been considered satisfactory for their intended purpose. However, there is still a need in the art for improved wedges having improved thermal conductivity while minimizing other losses. The present disclosure provides a solution for this need.

SUMMARY OF THE INVENTION

A rotor for a generator includes a shaft, a rotor core radially outward from the shaft and having a plurality of poles spanning axially along the rotor core, a plurality of windings wrapped axially around each of the plurality of poles, a plurality of wedges, each wedge being positioned between two adjacent poles of the plurality of poles, each wedge having a central portion comprising at least a first material, a first wing integrally attached to the central portion, and a second wing integrally attached to the central portion opposite the first wing, wherein the first wing, and the second wing include a second material.

Each of the windings can contact the second material of each of the wedges and not contact the first material of each of the wedges. The central portion can include the second material. The first material can be electrically non-conductive. The second material can be electrically conductive. The first material can include titanium. The second material can include aluminum. The central portion is primarily composed of the second material.

The central portion can include a quadrilateral section radially outward from a triangular central leg separating the first wing from the second wing. The quadrilateral section can include the first material and the second material. The quadrilateral section can include three outward facing edges, wherein each of the edges includes the second material, and two of the edges do not include the first material. The quadrilateral section can include a first “L” shaped portion including the second material. The quadrilateral section includes a second “L” shaped portion can include the second material bracketing a portion of the first material with the

2

first “L” shaped portion. It is also considered that the first wing and the second wing include the first material, a portion of an outer edge of the first wing, and a portion of an outer edge of the second wing include the first material.

5 The central portion can include an aperture configured to allow coolant oil flow. The central portion can include a fastener located radially inward of the aperture. The fastener can include steel.

10 These and other features of the systems and methods of the subject disclosure will become more readily apparent to those skilled in the art from the following detailed description of the preferred embodiments taken in conjunction with the drawings.

BRIEF DESCRIPTION OF THE DRAWINGS

15 So that those skilled in the art to which the subject disclosure appertains will readily understand how to make and use the devices and methods of the subject disclosure without undue experimentation, embodiments thereof will be described in detail herein below with reference to certain figures, wherein:

FIG. 1 is a schematic sectional view of a machine;

20 FIG. 2 is a perspective view of a wedge for the machine of FIG. 2; and

25 FIG. 3 is a perspective view of an embodiment of a wedge for the machine of FIG. 1.

DETAILED DESCRIPTION

30 Reference will now be made to the drawings wherein like reference numerals identify similar structural features or aspects of the subject disclosure. For purposes of explanation and illustration, and not limitation, a partial view of an exemplary embodiment of a rotor accordance with the disclosure is shown in FIG. 1 and is designated generally by reference character **100**. Other embodiments of the rotor and wedges used therein in accordance with the disclosure, or aspects thereof, are provided in FIGS. 2 and 3, as will be described. The disclosure describes a wedge that is both smooth on the outer diameter to reduce friction and windage, and yet limits high conductivity, both electrical and thermal, to regions where heat needs to be transferred.

35 FIG. 1 shows a cross-section of a machine **20** having a central shaft **26**, which is driven to rotate by a source of rotation, such as a gas turbine engine **27** (shown schematically) and adjacent to a stator **22** (shown schematically) to generate electricity. The rotor **24** includes a lamination stack **28** having poles **35** with circumferentially extending wedges **32**. The wedges **32** sit in a channel radially inwardly of circumferentially opposed pole tips **34** on poles **35**. The channels receive field coils or windings **30** and **31**, which are wound around the poles **35**. The wedge **32** separates and supports adjacent coils **30** and **31**.

40 FIG. 2 shows a detailed view of a wedge **32** of FIG. 1. The wedge **32** includes a central portion **40**. The central portion **40** includes a first material and a second material. A first wing **46** is integrally attached to the central portion **40**, and a second wing **48** is integrally attached to the central portion **40** opposite the first wing **46**. The first wing **46** and the second wing **48** include the second material only. Each of the windings, seen in FIG. 1, contact the wings **46**, **48** of each of the wedges and do not contact the first material section of each of the wedges.

45 The first material can be electrically non-conductive, such as titanium. The second material can be electrically conductive, such as aluminum. The central portion **40** is primarily

3

composed of the second material, with only a small portion touching the outer surface, with the outer surface having an air gap placed after it. The central portion 40 includes a quadrilateral section 50 positioned radially outward from a triangular central leg 52 which separates the first wing 46 from the second wing 48. The quadrilateral section 50 includes the small section 54 of the first material. The quadrilateral section 50 can include three outward facing edges 56, 58, 60, where each of the edges are partially made up of the second material, and two of the edges 56 and 60 do not include the first material. The quadrilateral section 50 includes a first "L" shaped portion 62 made of the second material and a second "L" shaped portion 64 bracketing the first material section 54. The central portion 40 also includes an oil flow aperture 68 and a fastener aperture 66 located radially inward of the aperture. The fastener can include steel, and more specifically cobalt steel.

FIG. 3 shows an embodiment of the wedge 32 wherein the first material section 54 hugs a second material section 153 such that each of the wings 46 and 48 include the first material. The central portion includes a trapezoidal portion 150 radially outward from the triangular central leg 52. The trapezoidal portion 150 includes the first material, and includes a first leg 161 and a second leg 163. The first leg 161 extends partially into the first wing 46 and the second leg 163 extends partially into the second wing 48 such that the first wing 46 and the second wing 48 include the first material and the second material. The first leg 161 and the second leg 163 can include respective "L" shaped portions, 162, 164. Each of the "L" shaped portions 162, 164 face away from the triangular central leg 52. The "L" shaped portions 162, 164 hug the portion 153 of the central portion 140 made of the second material.

The methods and systems of the present disclosure, as described above and shown in the drawings, provide for wedges with better conductivity properties. While the apparatus and methods of the subject disclosure have been shown and described with reference to preferred embodiments, those skilled in the art will readily appreciate that changes and/or modifications may be made thereto without departing from the scope of the subject disclosure.

What is claimed is:

1. A wedge for use in an electric machine comprising: a central portion comprising a first material; a first wing integrally attached to the central portion; and a second wing integrally attached to the central portion opposite the first wing, wherein the first wing and the second wing include at least a second material, wherein the central portion includes a trapezoidal portion radially outward from a triangular central leg, the triangular central leg separating the first wing from the second wing, wherein the trapezoidal portion includes the first material, wherein the trapezoidal portion includes a first leg and a second leg, wherein the first leg extends partially into the first wing and the second leg extends partially into the second wing such that the first wing and the second wing include the first material and the second material.
2. The wedge of claim 1, wherein the first material has a lower electrical conductivity relative to the second material.
3. The wedge of claim 2, wherein the first material includes titanium.
4. The wedge of claim 2, wherein the second material includes aluminum.

4

5. The wedge of claim 1, wherein the central portion is primarily composed of the second material.

6. The wedge of claim 1, wherein the first leg of the trapezoidal portion includes a first "L" shaped portion wherein the first "L" shaped portion faces away from the central portion.

7. The wedge of claim 6, wherein the second leg of the trapezoidal portion includes a second "L" shaped portion, wherein the second "L" shaped portion faces away from the central portion, wherein the first and second "L" shaped portions hug a portion of the first material of the central portion.

8. The wedge of claim 1, wherein the central portion includes a coolant aperture configured to allow coolant oil flow.

9. The wedge of claim 8, wherein the central portion includes a fastener or fastener aperture located radially inward of the coolant aperture.

10. The wedge of claim 9, wherein the fastener includes steel.

11. The wedge of claim 1, wherein the first material is different from the second material.

12. A rotor for a generator comprising:
- a shaft;
 - a rotor core radially outward from the shaft and having a plurality of poles spanning axially along the rotor core;
 - a plurality of windings wrapped axially around each of the plurality of poles; and
 - a plurality of wedges, each wedge being positioned between two adjacent poles of the plurality of poles, wherein each wedge includes:
 - a central portion comprising a first material;
 - a first wing integrally attached to the central portion; and
 - a second wing integrally attached to the central portion opposite the first wing, wherein the first wing and the second wing include at least a second material,
 wherein the central portion includes a trapezoidal portion of the first material radially outward from a triangular central leg, the triangular central leg separating the first wing from the second wing, wherein the trapezoidal portion includes a first leg and a second leg, wherein the first leg extends partially into the first wing and the second leg extends partially into the second wing such that the first wing and the second wing include the first material and the second material.

13. The rotor of claim 12, wherein each of the windings contacts the second material of each of the wedges.

14. The rotor of claim 12, wherein each of the windings does not contact the first material of each of the wedges.

15. The rotor of claim 12, wherein the first leg of the trapezoidal portion includes a first "L" shaped portion, wherein the first "L" shaped portion faces away from the central portion.

16. The rotor of claim 15, wherein the second leg of the trapezoidal portion includes a second "L" shaped portion, wherein the second "L" shaped portion faces away from the central portion, wherein the first and second "L" shaped portions hug a portion of the first material of the central portion.

* * * * *