



US011930794B2

(12) **United States Patent**
Radzyner

(10) **Patent No.:** **US 11,930,794 B2**
(45) **Date of Patent:** **Mar. 19, 2024**

(54) **AUTONOMOUS BEEHIVES**

(71) Applicant: **BEEWISE TECHNOLOGIES LTD.**,
Clil (IL)

(72) Inventor: **Eliyah Radzyner**, Clil (IL)

(73) Assignee: **Beewise Technologies LTD.**, Kibbutz
Beit-Haemek (IL)

(*) Notice: Subject to any disclaimer, the term of this
patent is extended or adjusted under 35
U.S.C. 154(b) by 0 days.

(21) Appl. No.: **17/835,163**

(22) Filed: **Jun. 8, 2022**

(65) **Prior Publication Data**

US 2022/0295760 A1 Sep. 22, 2022

Related U.S. Application Data

(63) Continuation of application No. 16/872,769, filed on
May 12, 2020, which is a continuation-in-part of
application No. PCT/IL2018/051223, filed on Nov.
13, 2018.

(60) Provisional application No. 62/904,695, filed on Sep.
24, 2019, provisional application No. 62/904,699,
filed on Sep. 24, 2019, provisional application No.
62/904,701, filed on Sep. 24, 2019, provisional
application No. 62/904,703, filed on Sep. 24, 2019,
(Continued)

(51) **Int. Cl.**

A01K 59/00 (2006.01)
A01K 47/06 (2006.01)
A01K 51/00 (2006.01)
A01K 53/00 (2006.01)

(52) **U.S. Cl.**

CPC **A01K 59/00** (2013.01); **A01K 47/06**
(2013.01); **A01K 51/00** (2013.01); **A01K 53/00**
(2013.01)

(58) **Field of Classification Search**

CPC **A01K 59/00**; **A01K 47/00**; **A01K 51/00**;
A01K 53/00

See application file for complete search history.

(56) **References Cited**

U.S. PATENT DOCUMENTS

1,768,041 A * 2/1928 Fenno **A01K 47/00**
3,456,056 A 7/1969 Reich et al.

(Continued)

FOREIGN PATENT DOCUMENTS

CN 101720680 A 6/2010
CN 203087245 U 7/2013

(Continued)

OTHER PUBLICATIONS

Communication and Supplementary Partial European Search Report
for Application No. EP 20 86 8356; dated Feb. 22, 2023 (10 pages).

(Continued)

Primary Examiner — Joshua J Michener

Assistant Examiner — Henry Hooper Mudd

(57) **ABSTRACT**

A system including: a plurality of bee frames releasably
mounted within at least one hive chamber; a mechanism that
extracts a bee frame from a hive chamber and inserts a bee
frame into a hive chamber; an imaging system that acquires
an image of a frame; and a processing unit which: deter-
mines, based on processing the image, the specific content of
each of a plurality of cells in the frame, and predicts a
possibility of swarming based on identifying, in the image,
at least one cell including a queen larva.

2 Claims, 23 Drawing Sheets

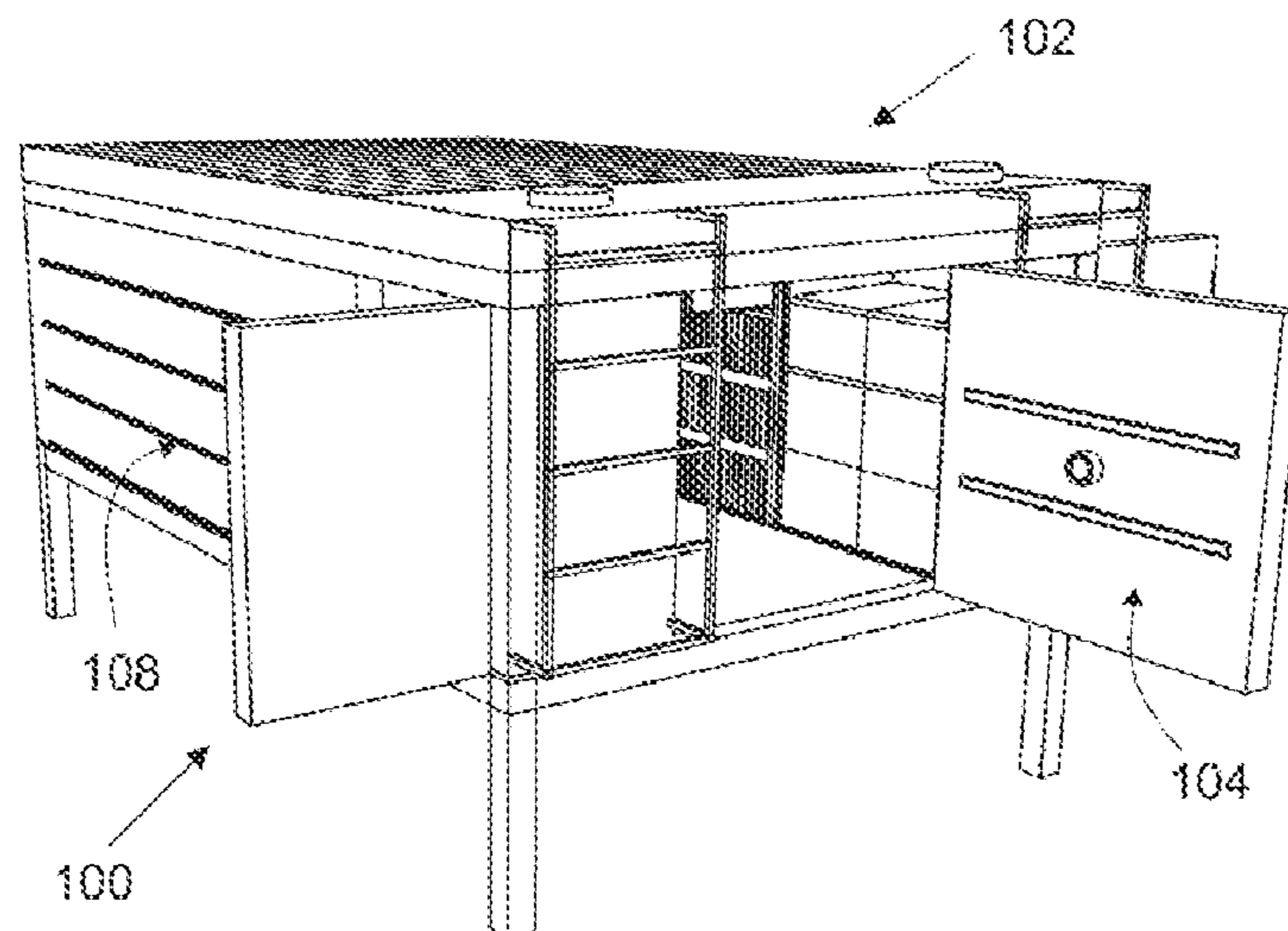

Related U.S. Application Data

provisional application No. 62/584,952, filed on Nov. 13, 2017.

WO 2019092731 A1 5/2019
 WO WO 2019/148235 8/2019
 WO 2021059282 A1 4/2021

(56)

References Cited

U.S. PATENT DOCUMENTS

3,771,179 A * 11/1973 Ogilby A01K 49/02
 6/12 A
 3,789,443 A 2/1974 Cowen
 3,914,812 A 10/1975 Kent
 3,999,237 A 12/1976 Solomon
 4,288,880 A 9/1981 Gary et al.
 4,520,519 A 6/1985 Kuehl
 4,573,228 A 3/1986 Bachalo
 5,685,762 A 11/1997 Penrose et al.
 6,475,061 B1 11/2002 Huang
 6,524,058 B1 2/2003 Watters
 8,602,837 B1 12/2013 Allan
 10,645,910 B1 5/2020 Gil Gonzalez
 10,757,921 B1 9/2020 Wood
 2002/0086430 A1 7/2002 Hopmeier
 2012/0202403 A1 8/2012 Sinanis et al.
 2014/0212520 A1 7/2014 Del Vecchio
 2014/0370781 A1 12/2014 Anderson et al.
 2015/0049919 A1 2/2015 Humal
 2016/0015007 A1 1/2016 Sinanis
 2017/0064931 A1 3/2017 Tagliaferri
 2017/0360010 A1 12/2017 Wilson-Rich
 2018/0160656 A1 6/2018 Ben-Shimon et al.
 2018/0288977 A1 10/2018 Hummer
 2020/0267945 A1* 8/2020 Symes A01K 47/06
 2020/0315143 A1 10/2020 Radzyner
 2020/0349397 A1 11/2020 Criswell et al.
 2021/0161107 A1 6/2021 Gamberoni et al.
 2021/0289765 A1 9/2021 Scofield et al.
 2022/0022429 A1 1/2022 Hummer et al.
 2022/0264854 A1 8/2022 Radzyner
 2022/0369602 A1 11/2022 Radzyner et al.

FOREIGN PATENT DOCUMENTS

CN 10358334 A 2/2014
 CN 103583416 A 2/2014
 CN 105 519 456 A 4/2016
 CN 205511589 U 8/2016
 CN 205511592 U 8/2016
 CN 106 719 106 A 5/2017
 CN 107047378 A 8/2017
 CN 108668955 A 10/2018
 DE 20 2006 007269 U1 7/2006
 DE 10 2013 006265 A1 10/2014
 IT UB20159742 A1 6/2017
 KR 20120060253 A * 9/2010 A01K 51/00
 KR 200460083 Y1 5/2012
 KR 20120045211 A 5/2012
 KR 20120060253 A 6/2012
 KR 20120102497 A 9/2012
 KR 101244803 B1 3/2013
 KR 20140059538 A 5/2014
 KR 200475229 Y1 11/2014
 KR 20160101621 A 8/2016
 KR 20180054182 A 5/2018
 KR 102093334 B1 3/2020
 WO 2012108857 A1 8/2012

OTHER PUBLICATIONS

Communication and European Search Report for Application No. EP 22 19 7442; dated Feb. 2, 2023 (7 pages).
 Communication and European Search Report for Application No. EP 22 19 7464; dated Feb. 2, 2023 (9 pages).
 USPTO office action for U.S. Appl. No. 17/857,071; dated Oct. 20, 2022 (27 pages).
 Communication Pursuant to Article 94(3) EPC dated Nov. 6, 2023 From the European Patent Office Re. Application No. 2219764.5. (7 Pages).
 Communication Pursuant to Article 94(3) EPC dated Aug. 28, 2023 From the European Patent Office Re. Application No. 22197442.1. (7 Pages).
 International Preliminary Report on Patentability dated May 19, 2020 From the International Bureau of WIPO Re. Application No. PCT/IL2018/051223. (7 Pages).
 International Search Report and the Written Opinion dated Jan. 6, 2021 From the International Searching Authority Re. Application No. PCT/IL2020/051052. (11 Pages).
 International Search Report and the Written Opinion dated Feb. 17, 2019 From the International Searching Authority Re. Application No. PCT/IL2018/051223. (11 Pages).
 Interview Summary dated Nov. 6, 2023 from U.S. Patent and Trademark Office Re. U.S. Appl. No. 17/737,147. (2 pages).
 Invitation pursuant to Rule 137(4) EPC and Article 94(3) EPC Dated Sep. 20, 2023 From the European Patent Office Re. Application No. 18876119.1. (5 Pages).
 Notice of Allowance dated Nov. 8, 2023 from U.S. Patent and Trademark Office Re. U.S. Appl. No. 17/737,147. (10 pages).
 Notification of Office Action dated Oct. 28, 2020 From the State Intellectual Property Office of the People's Republic of China Re. Application No. 201880073417.7. (7 Pages).
 Office Action dated Jul. 9, 2023 From the Israel Patent Office Re. Application No. 274613. (3 Pages).
 Official Action dated May 3, 2023 from U.S. Patent and Trademark Office Re. U.S. Appl. No. 17/737,147. (25 pages).
 Official Action dated Apr. 4, 2022 from U.S. Patent and Trademark Office Re. U.S. Appl. No. 16/872,769. (36 pages).
 Official Action dated Dec. 6, 2023 from U.S. Patent and Trademark Office Re. U.S. Appl. No. 17/762,211. (20 pages).
 Official Action dated Sep. 7, 2023 From the U.S. Patent and Trademark Office Re. U.S. Appl. No. 16/872,769. (40 Pages).
 Official Action dated Jul. 19, 2023 from U.S. Patent and Trademark Office Re. U.S. Appl. No. 17/737,147. (24 pages).
 Official Action dated Nov. 21, 2022 from U.S. Patent and Trademark Office Re. U.S. Appl. No. 17/737,147. (21 pages).
 Restriction Official Action dated Nov. 3, 2021 from the U.S. Patent and Trademark Office Re. U.S. Appl. No. 16/872,769. (9 pages).
 Supplementary European Search Report and the European Search Opinion dated Oct. 30, 2020 From the European Patent Office Re. Application No. 18876119.1. (9 Pages).
 Translation dated Nov. 23, 2020 of Notification of Office Action dated Oct. 28, 2020 From the State Intellectual Property Office of the People's Republic of China Re. Application No. 201880073417.7. (11 Pages).

* cited by examiner

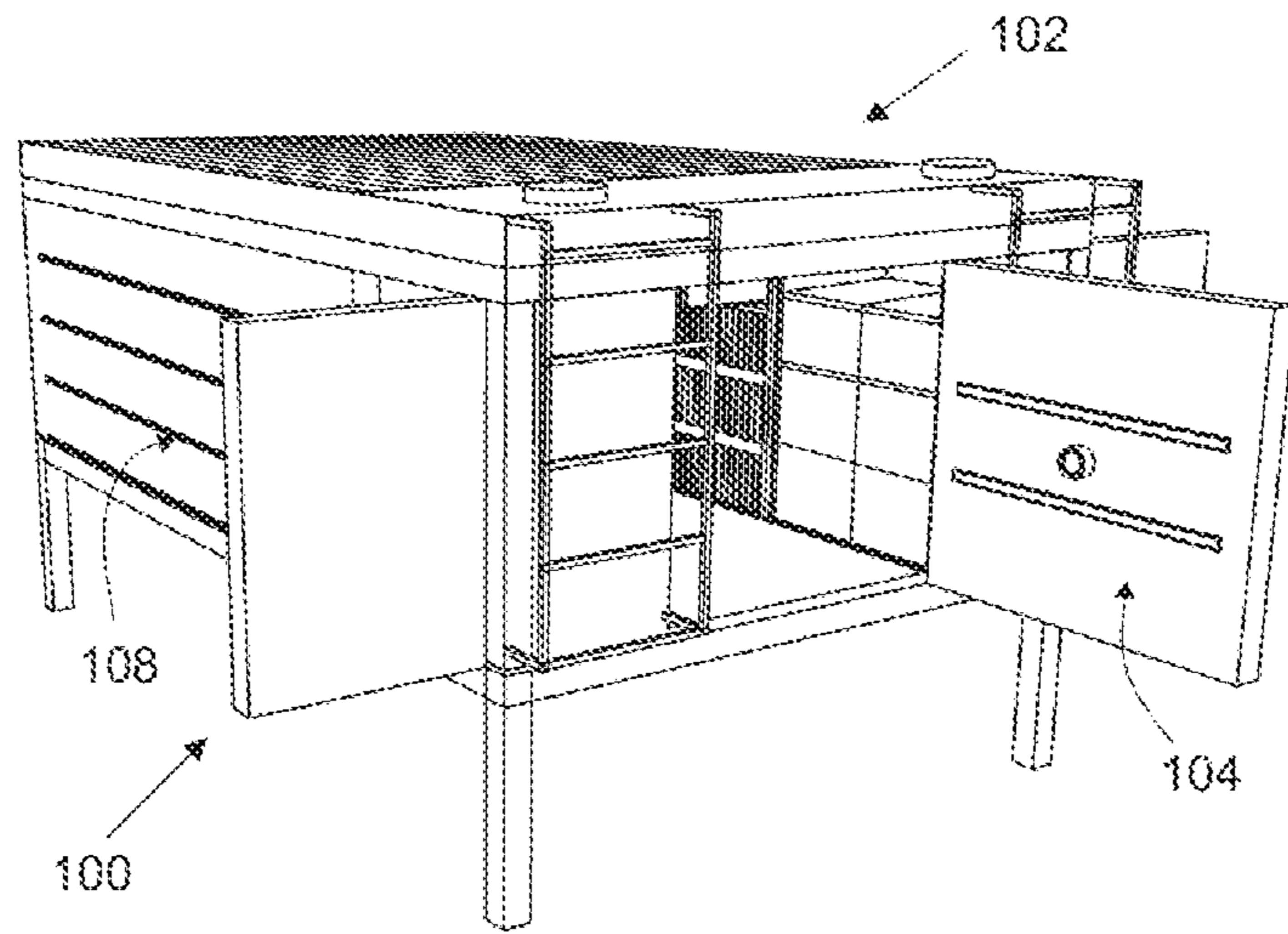

Fig. 1a

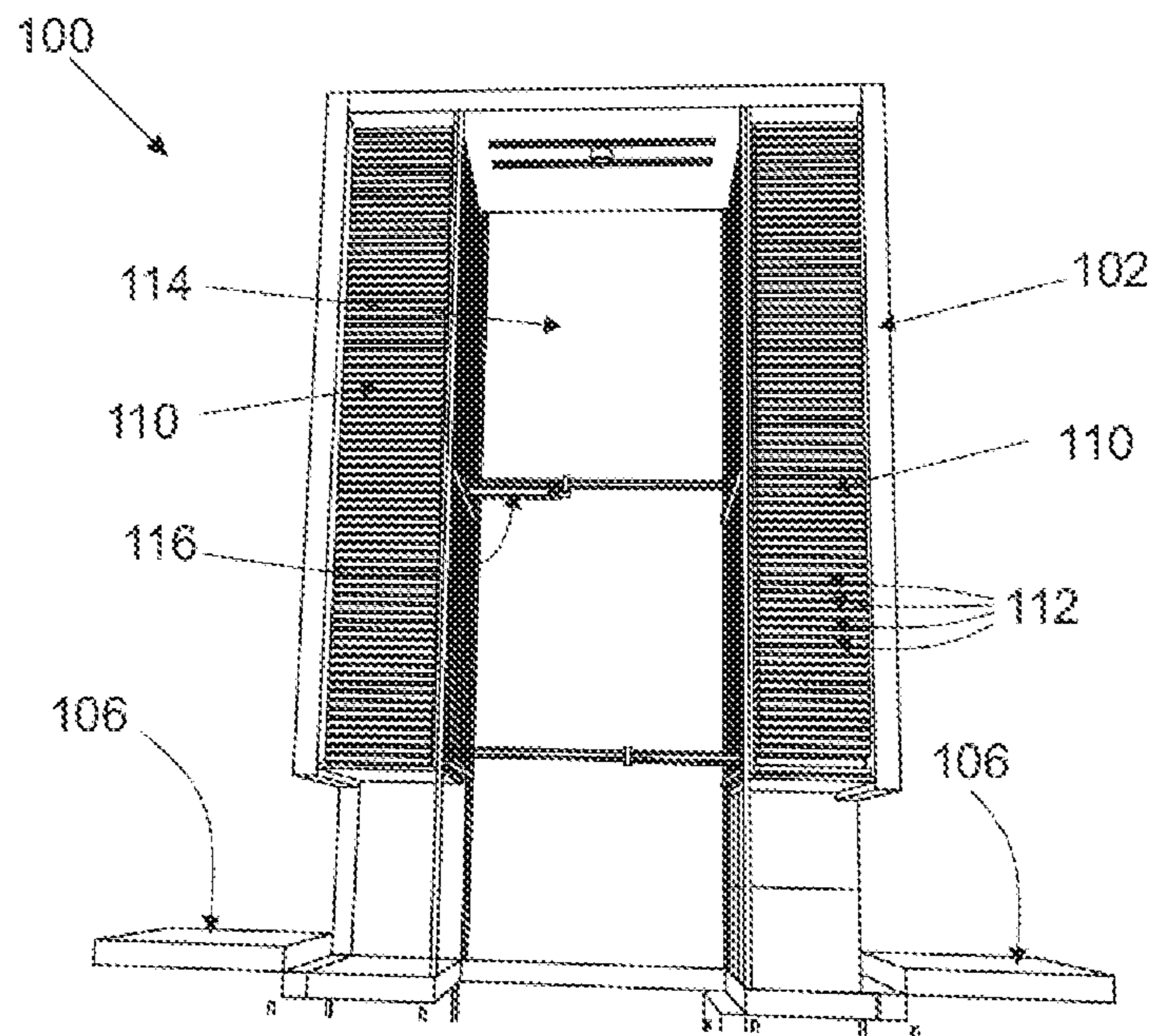

Fig. 1b

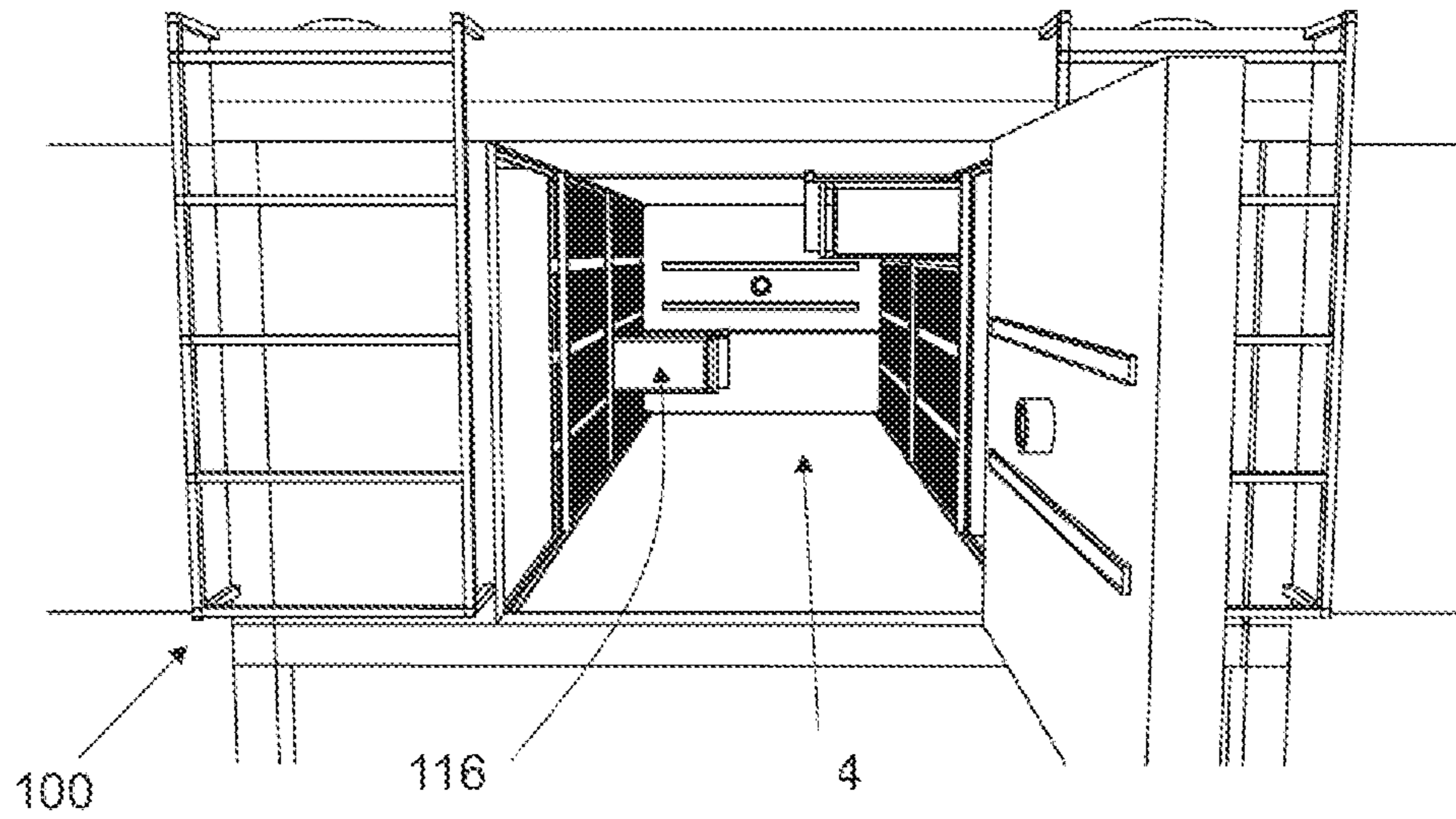

Fig. 1c

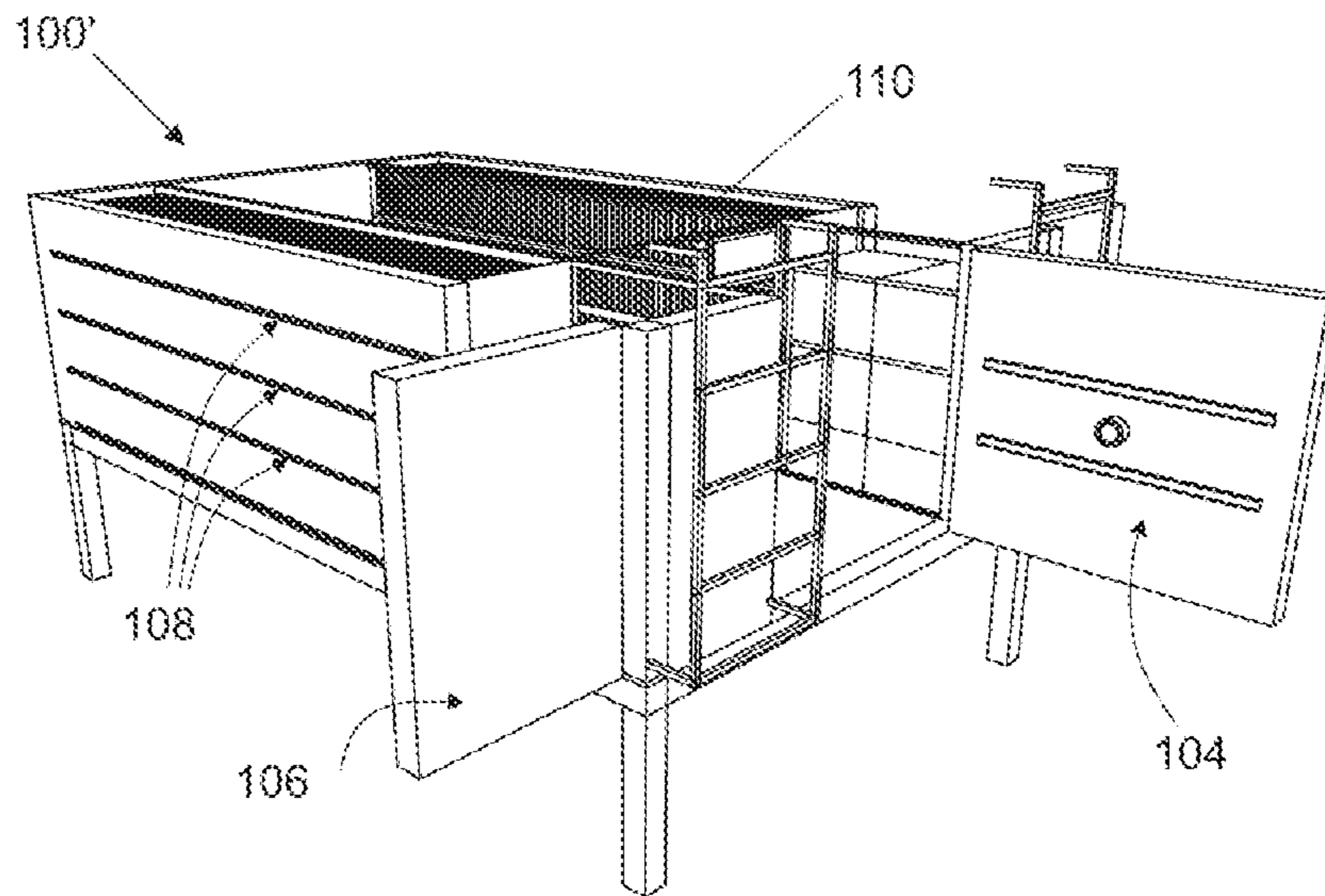

Fig. 1d

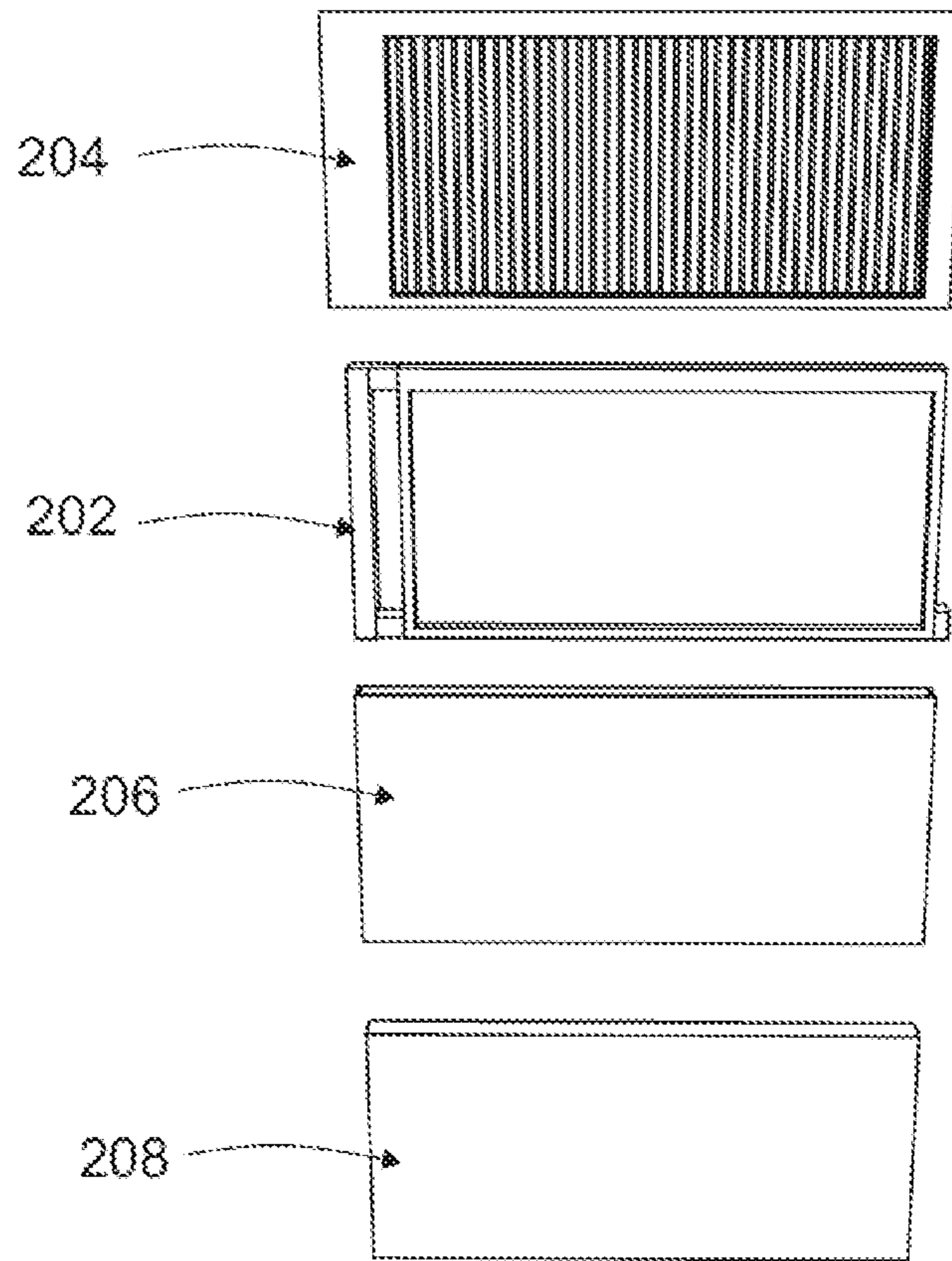

Fig. 2

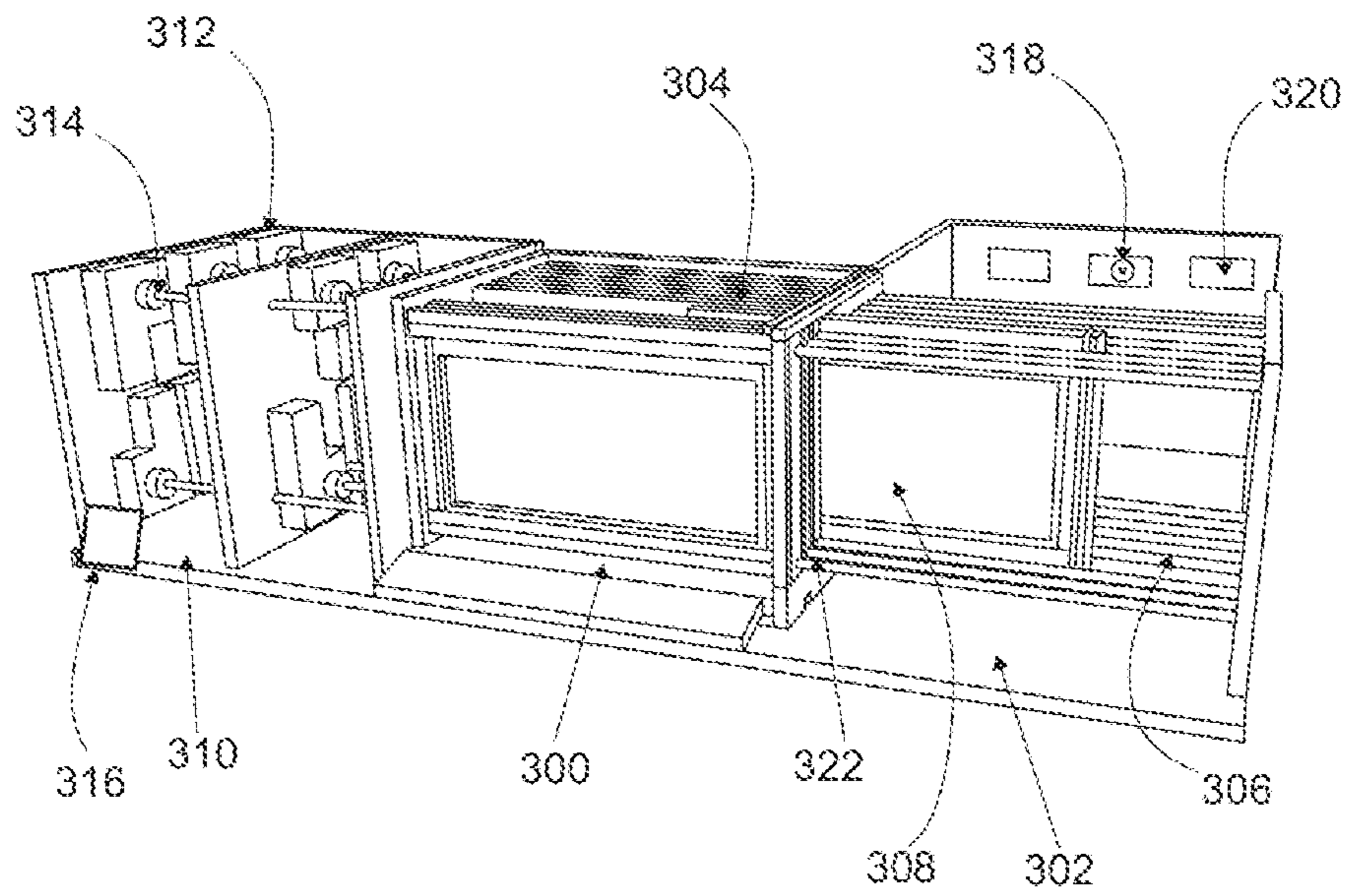

Fig. 3

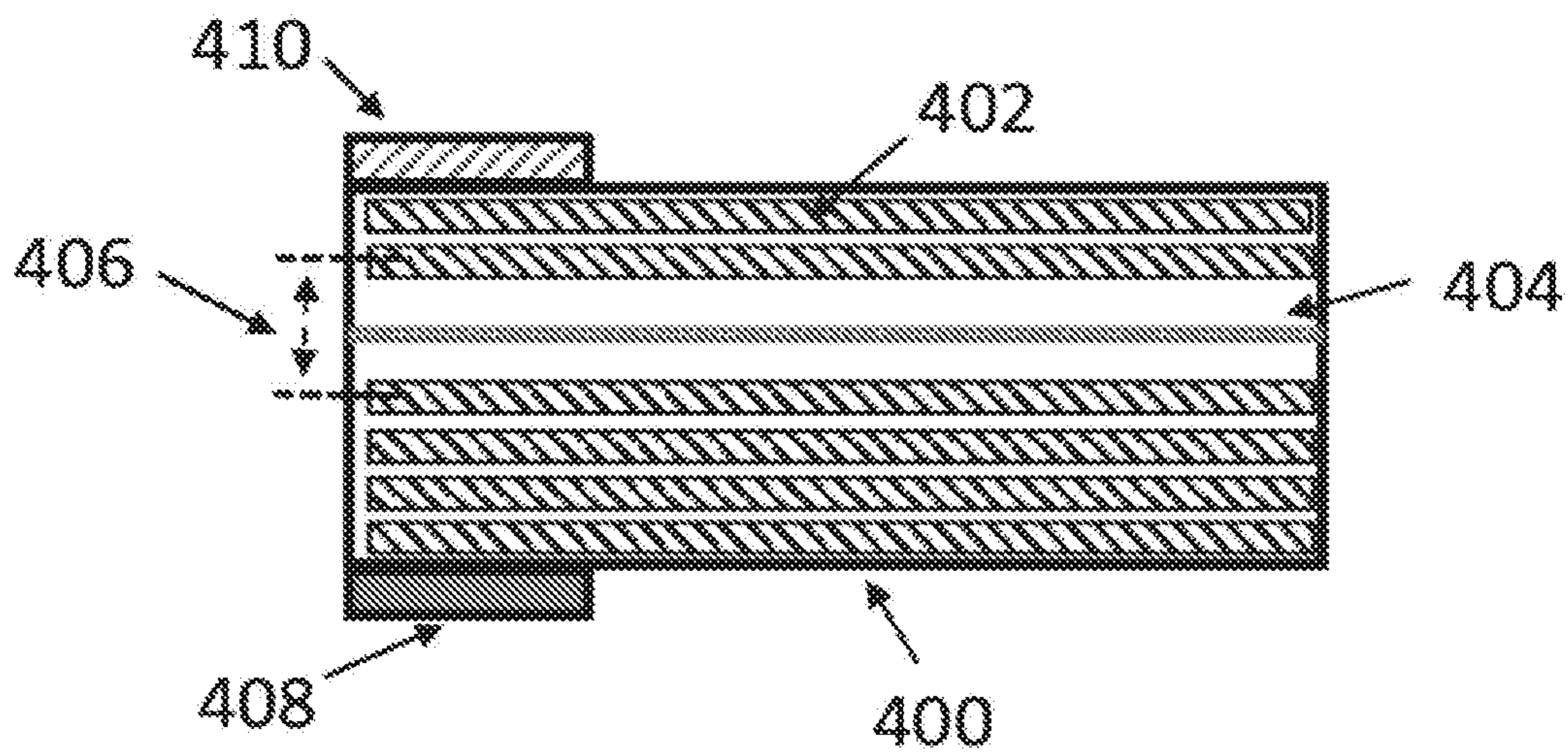

Fig. 4

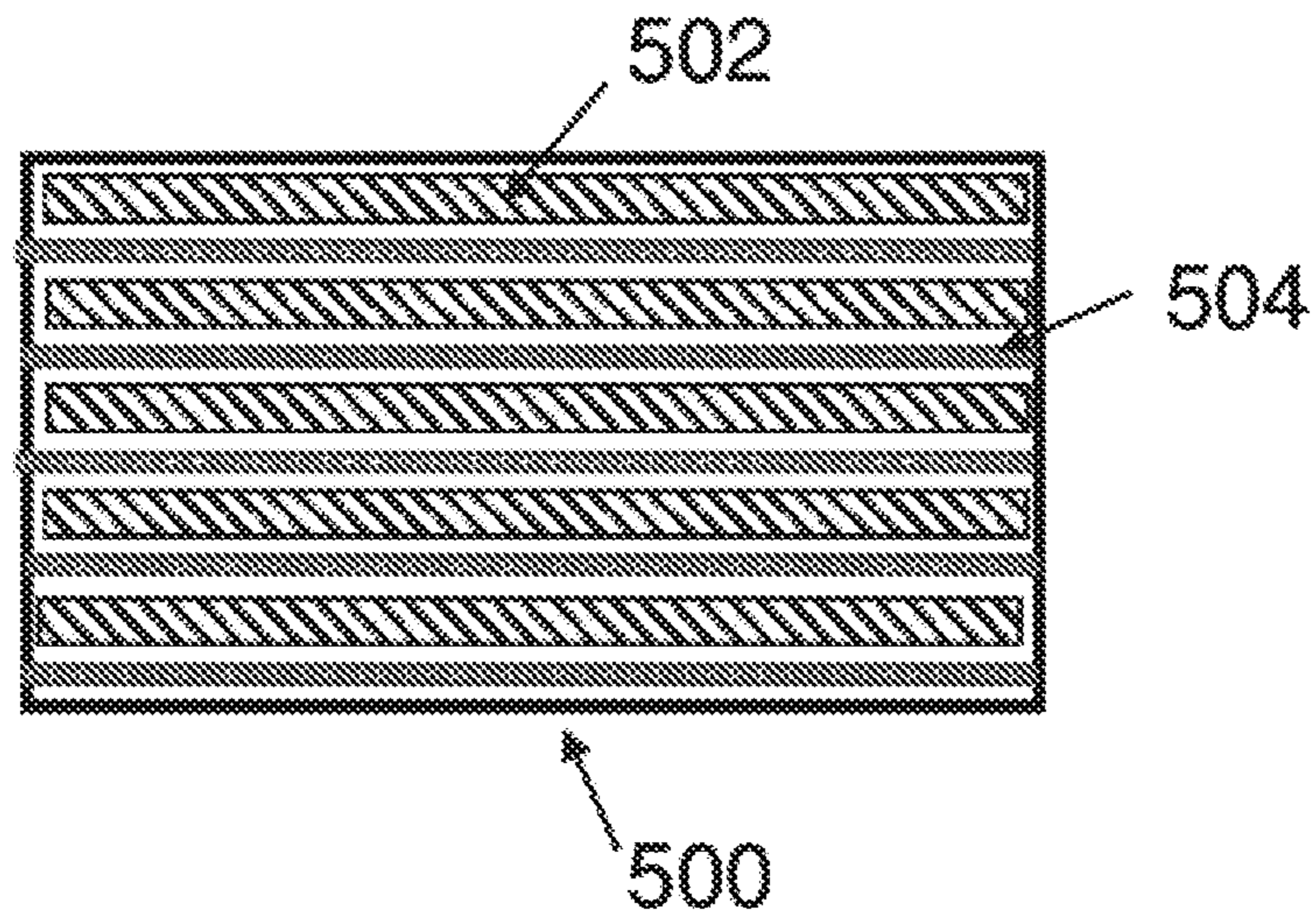

Fig. 5

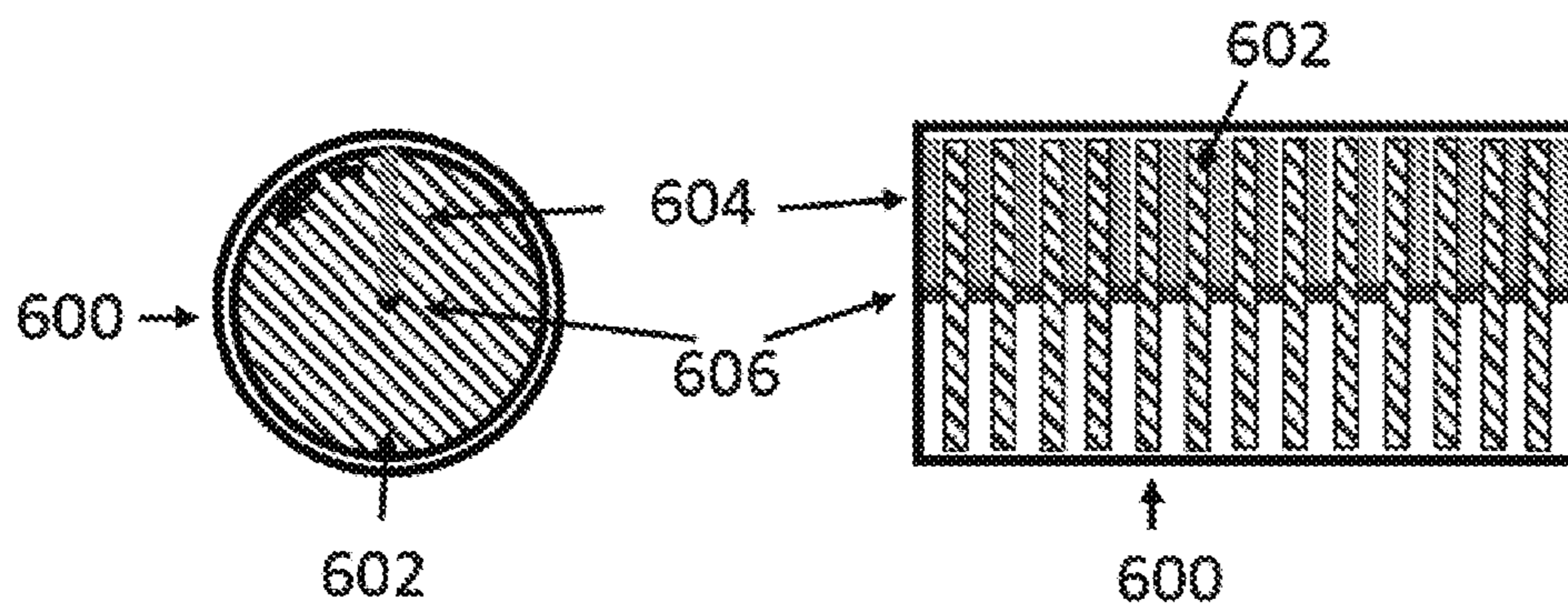

Fig. 6

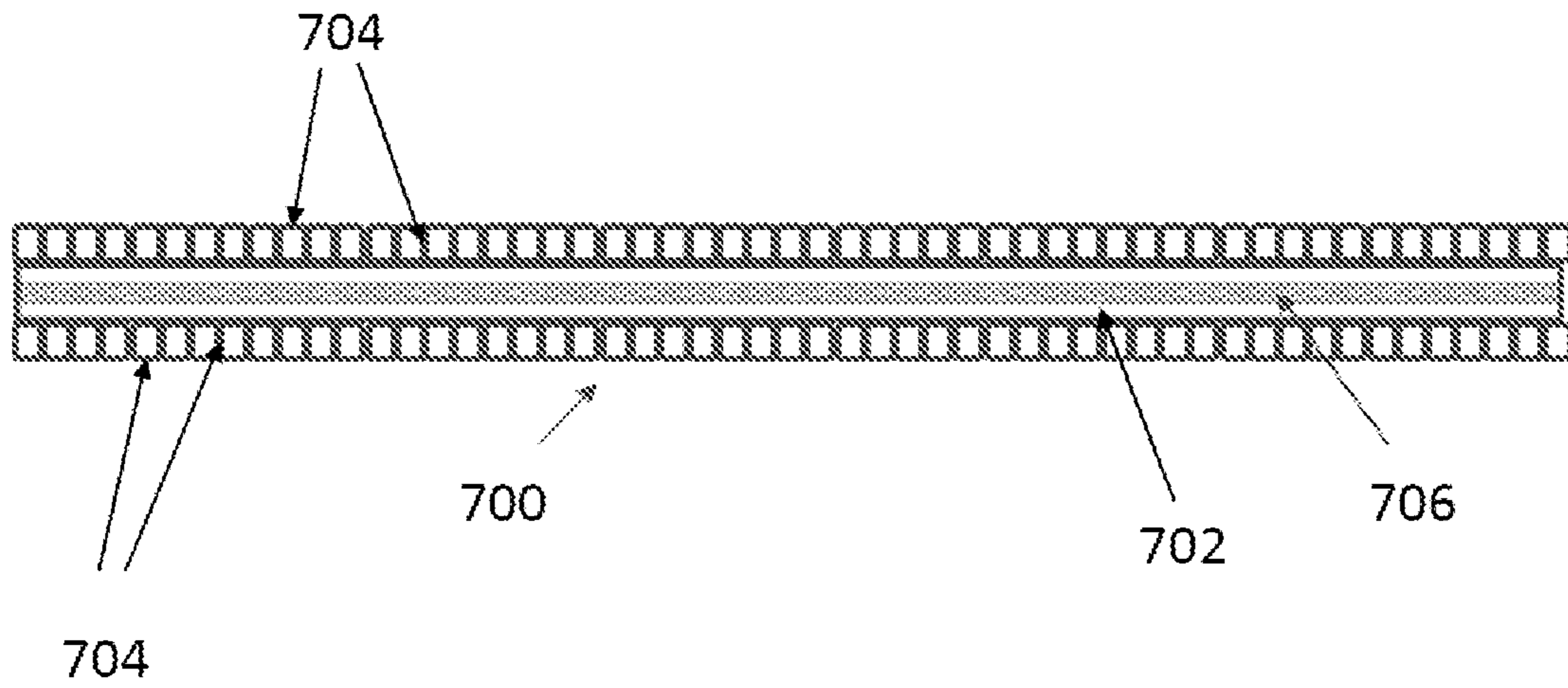

Fig. 7

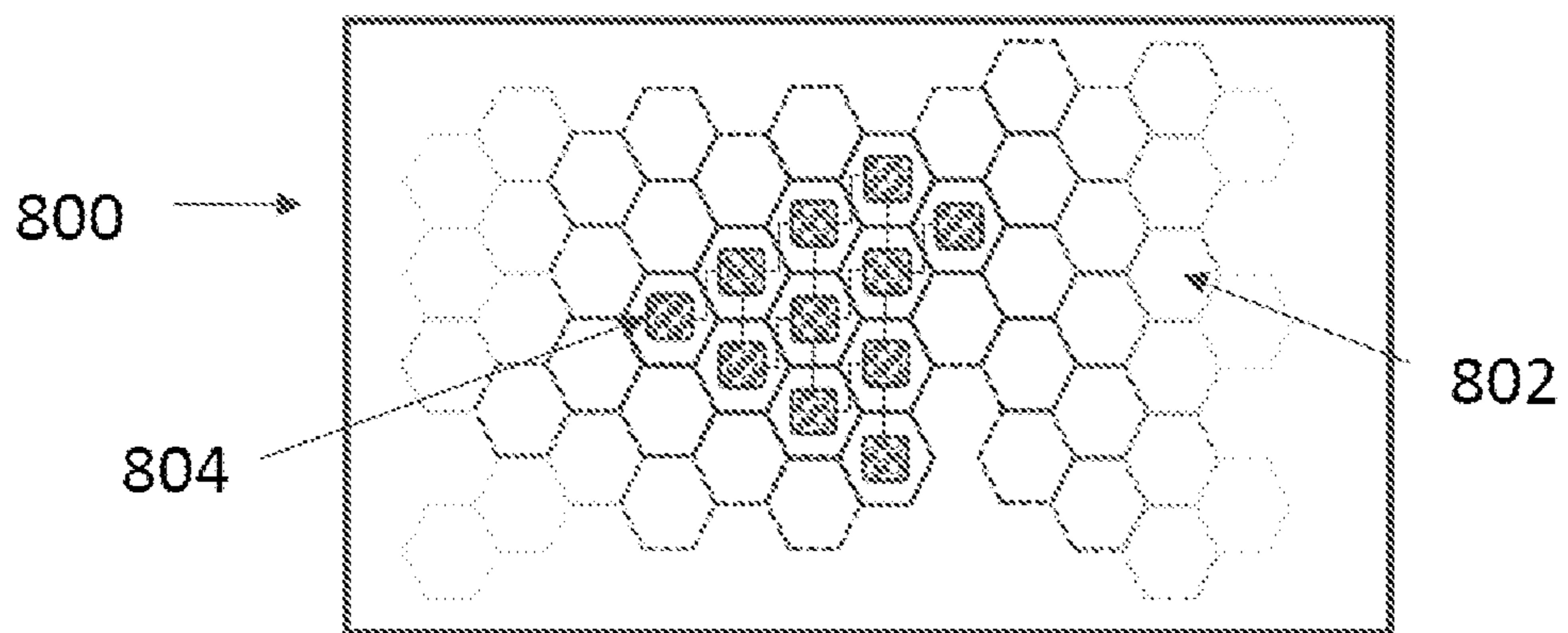

Fig. 8

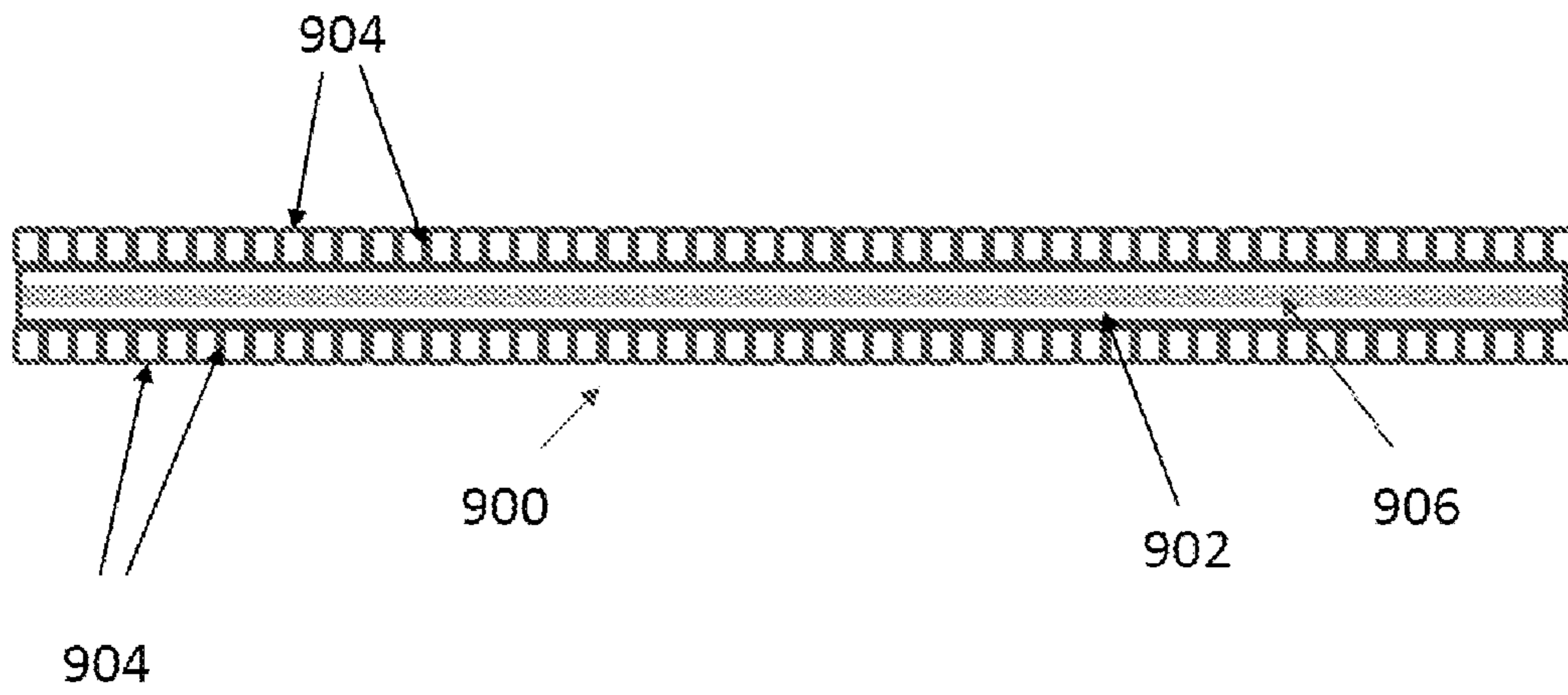

Fig. 9

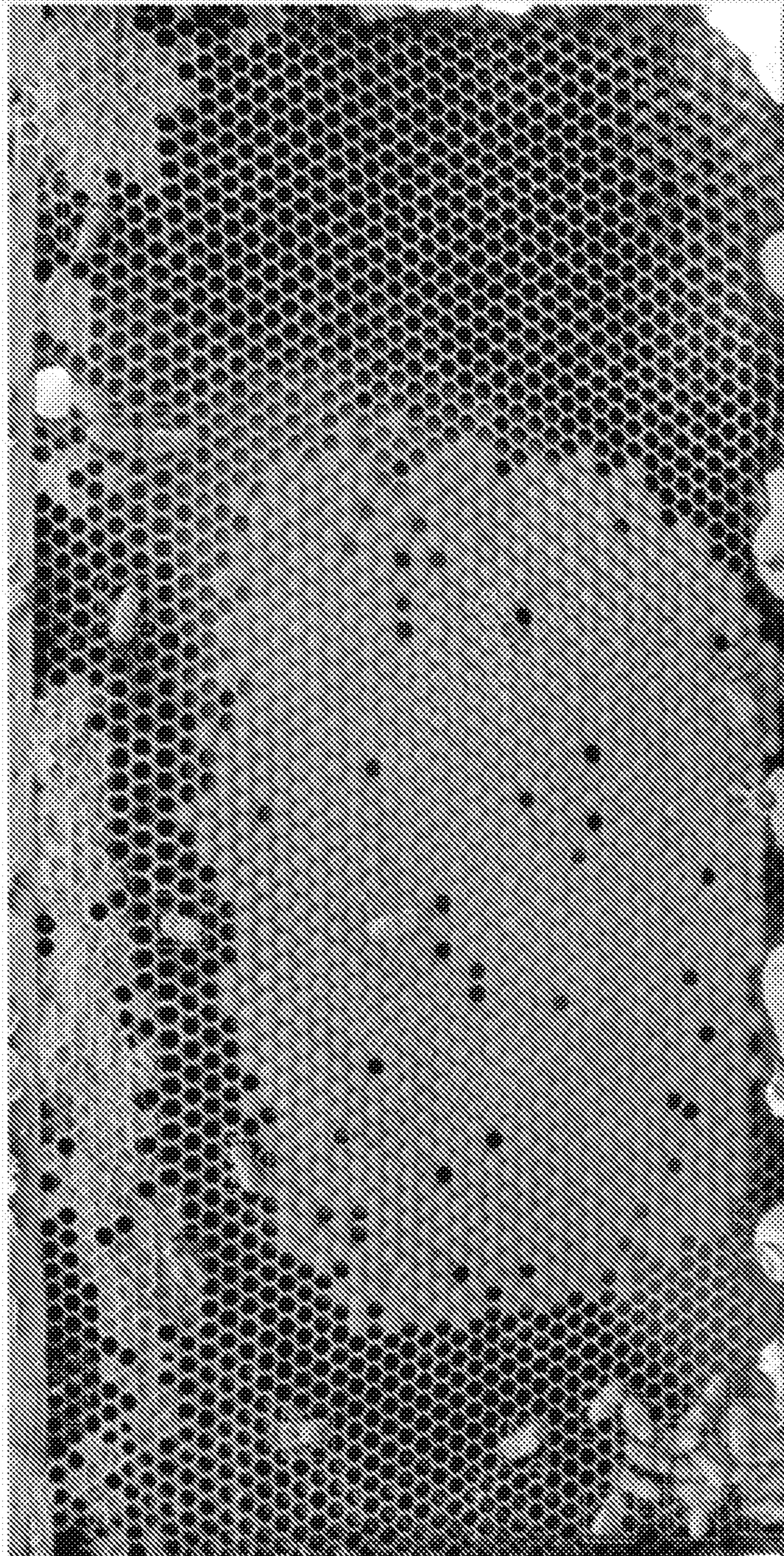

Fig. 10a

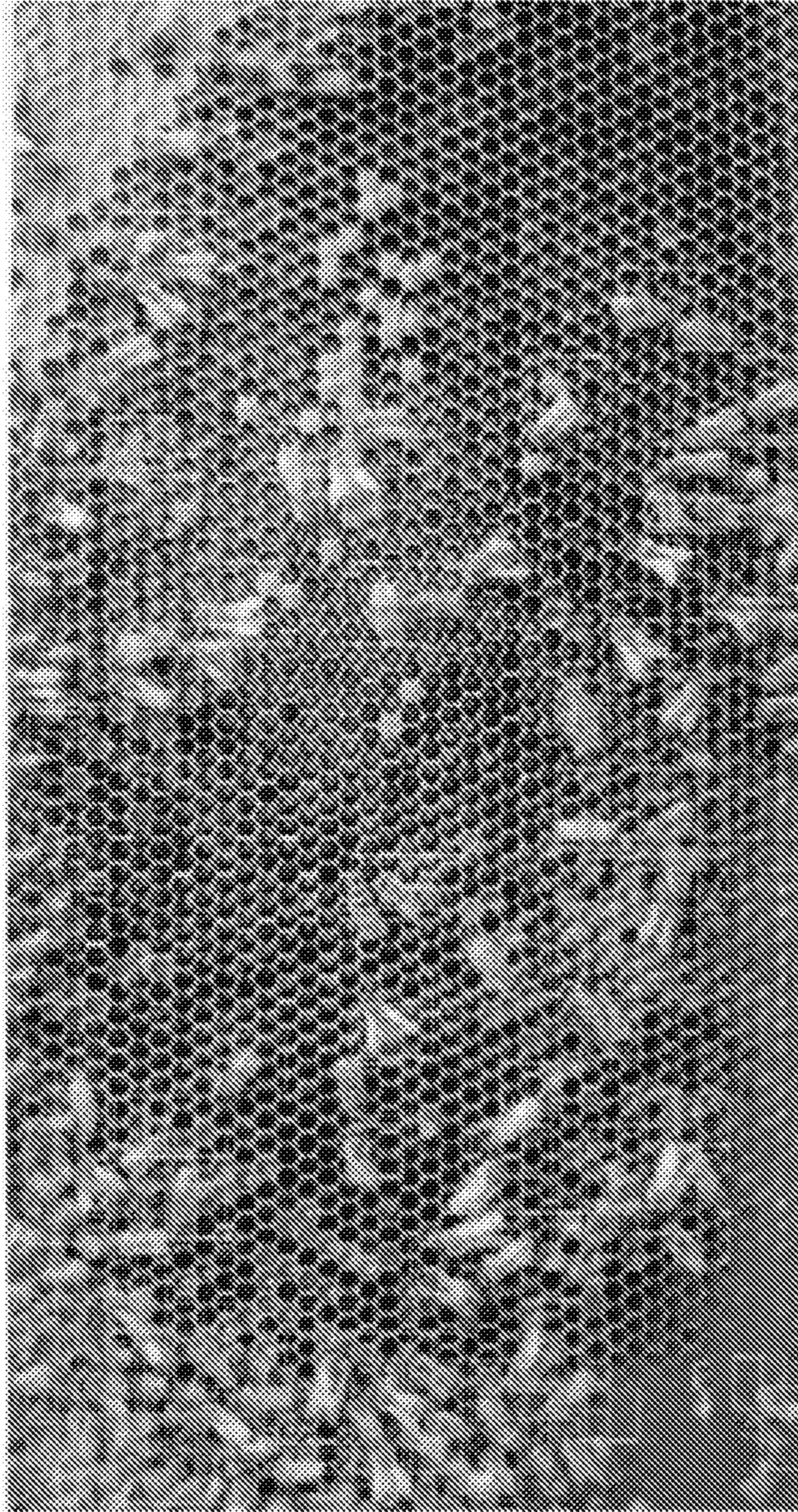

Fig. 10b

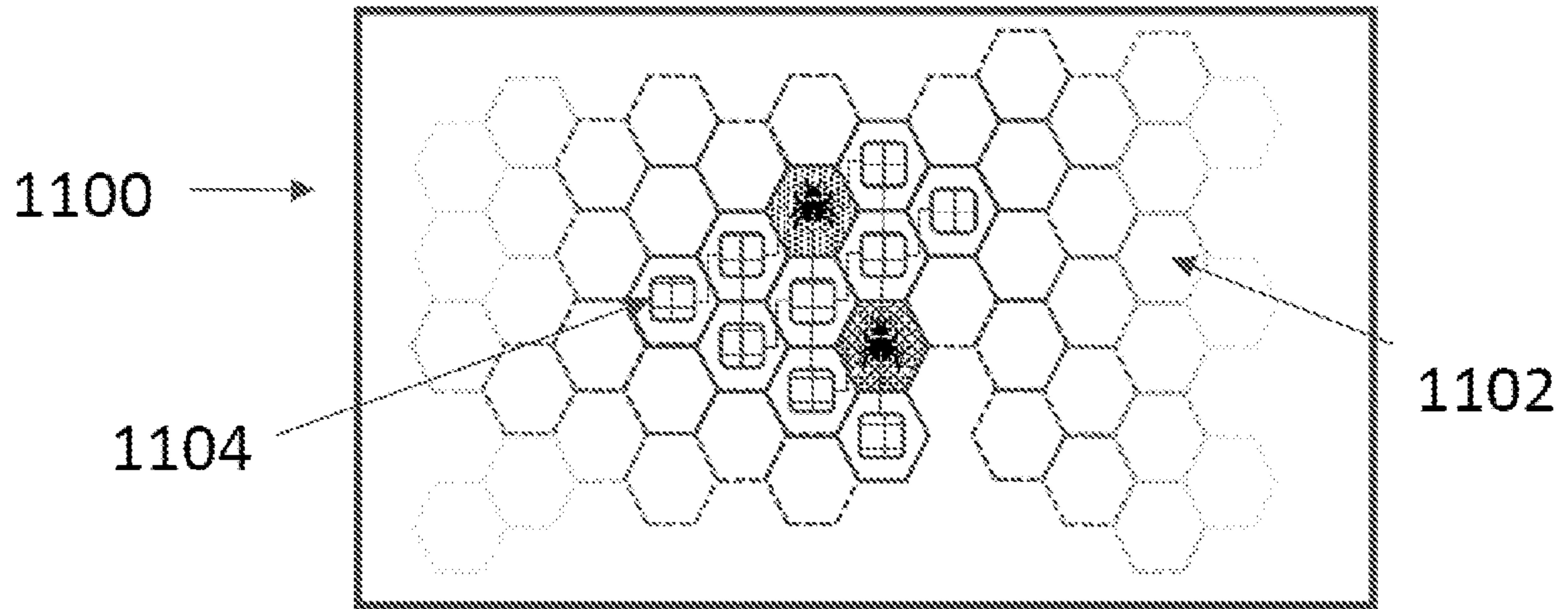

Fig. 11

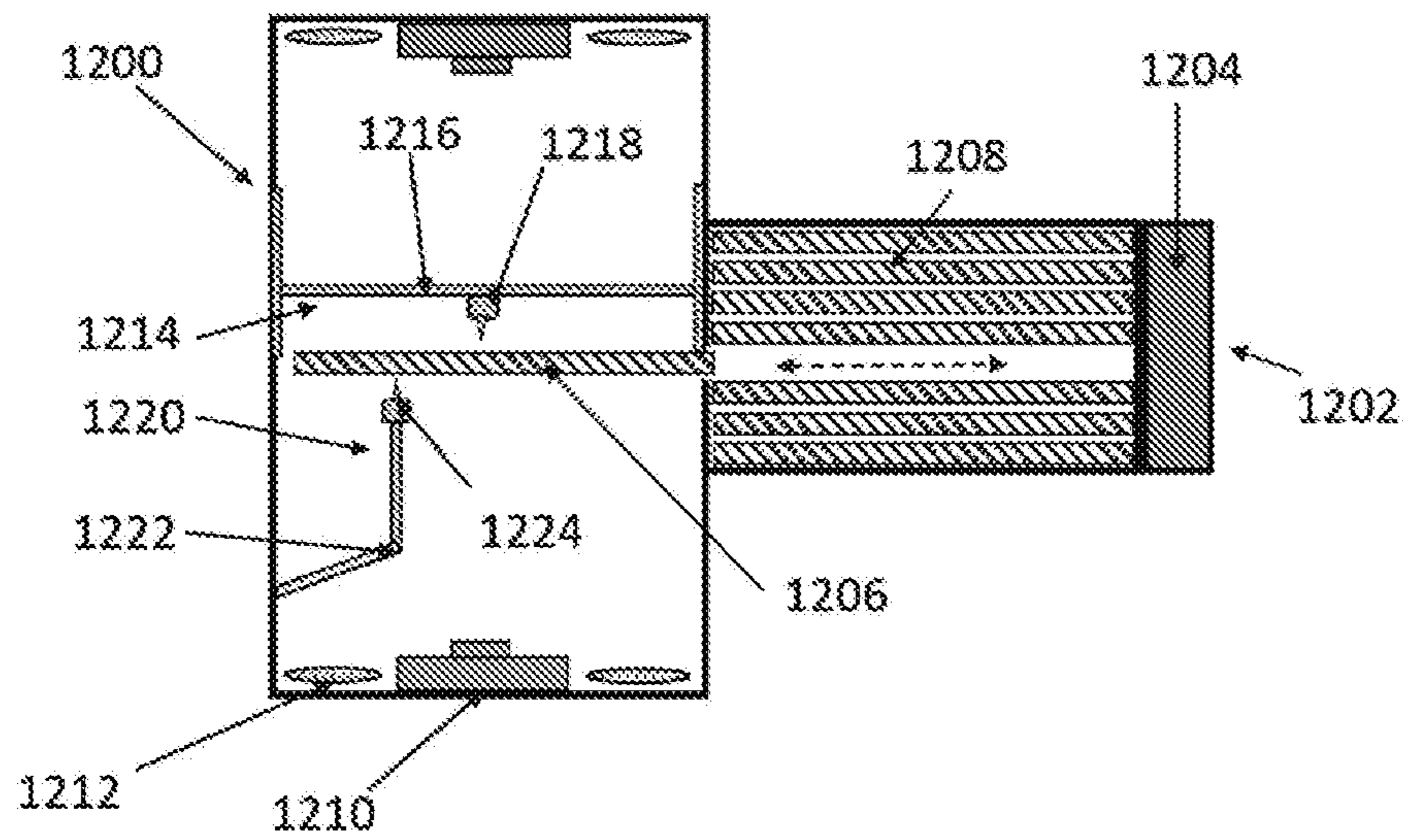

Fig. 12

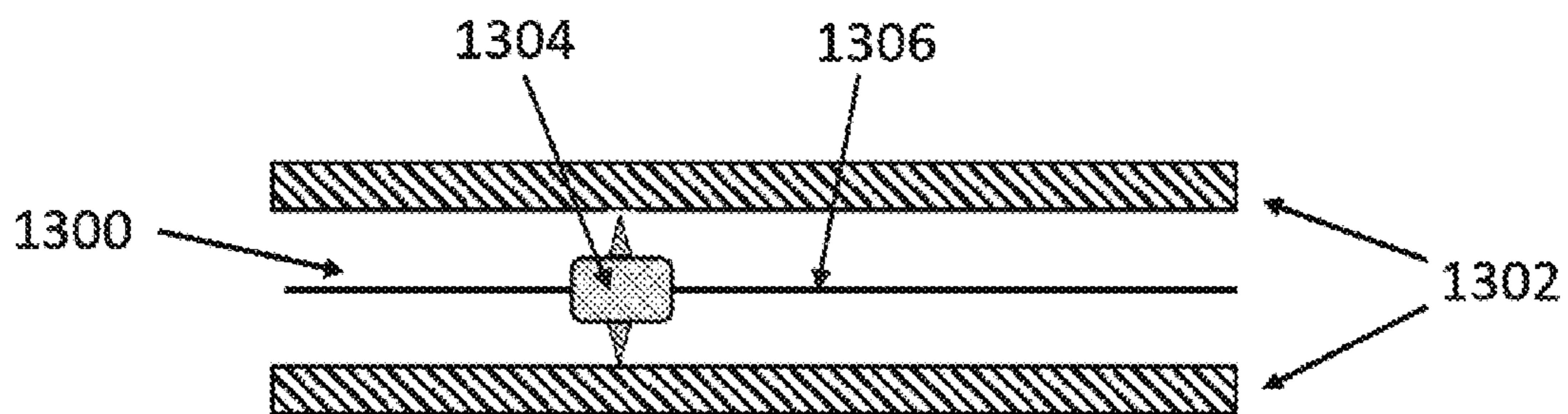

Fig. 13

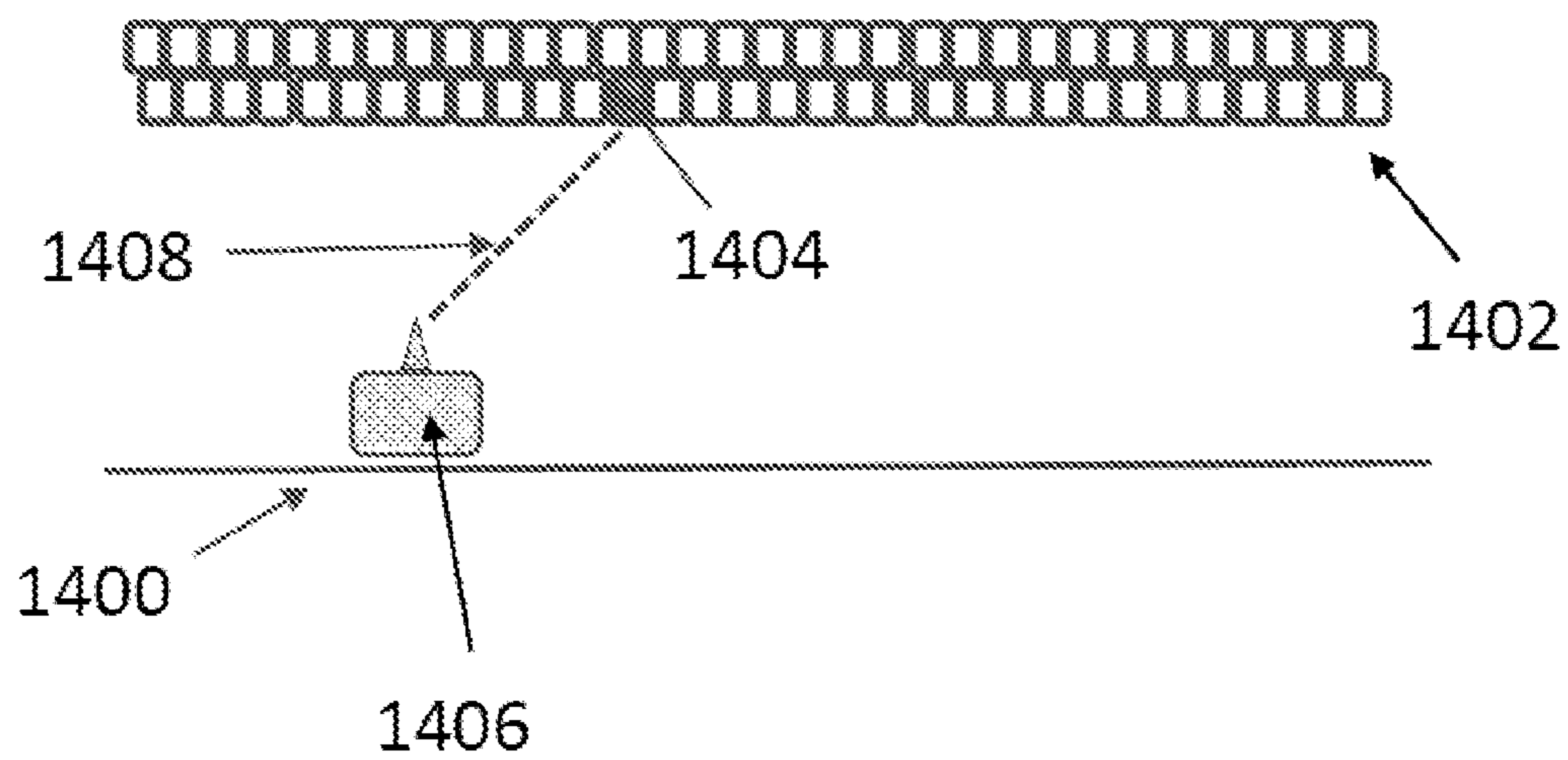

Fig. 14

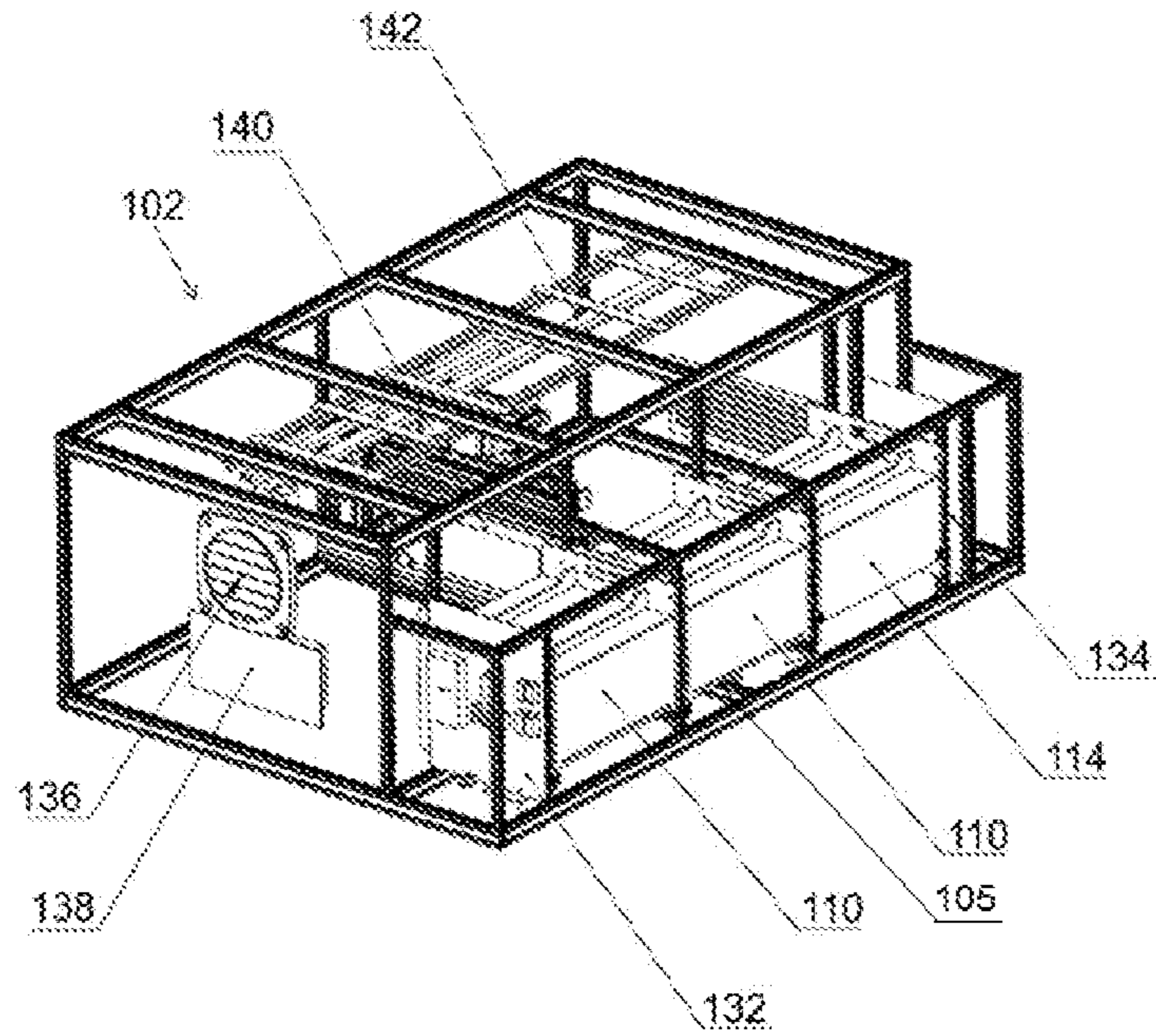

Fig. 15

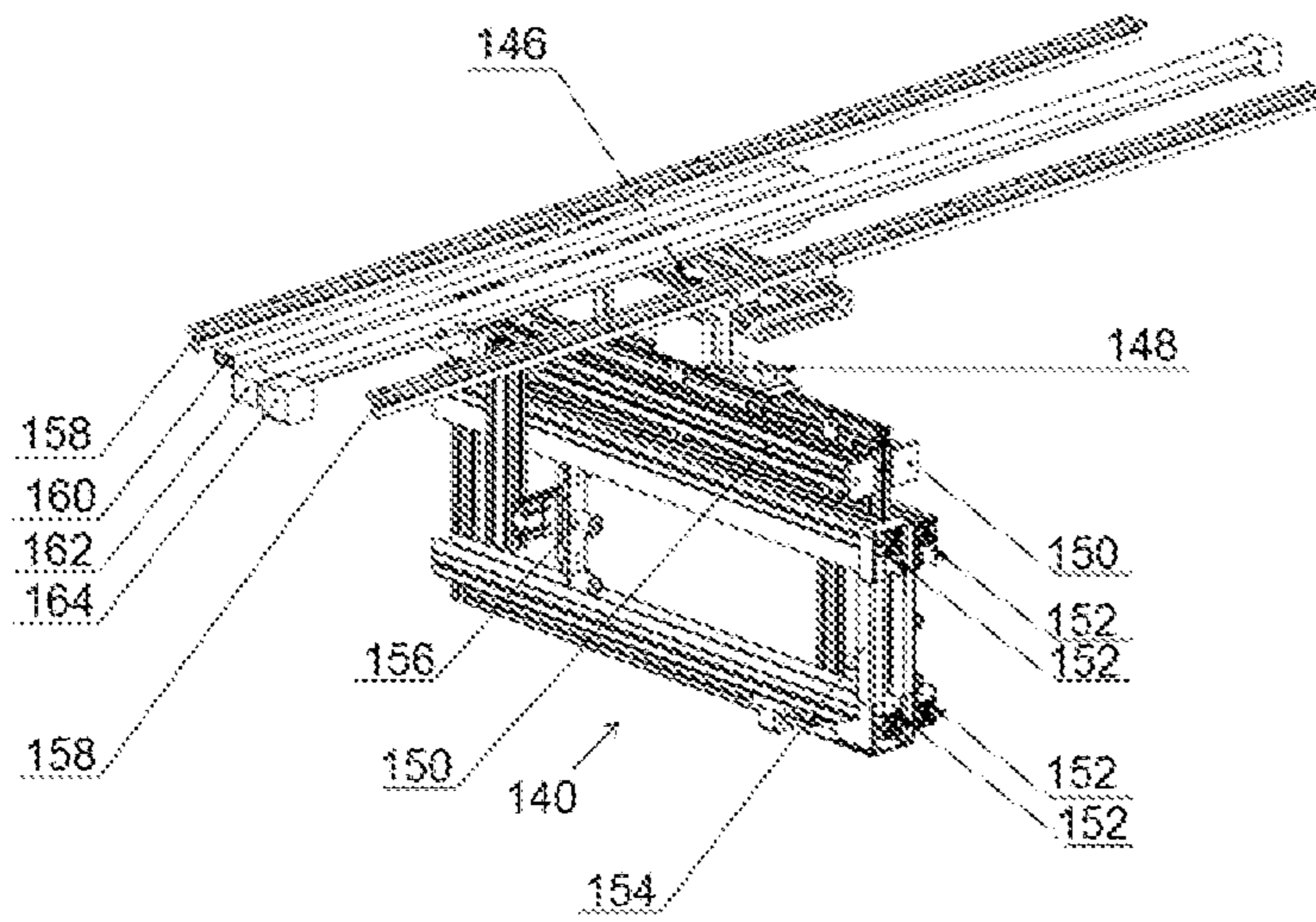

Fig. 16

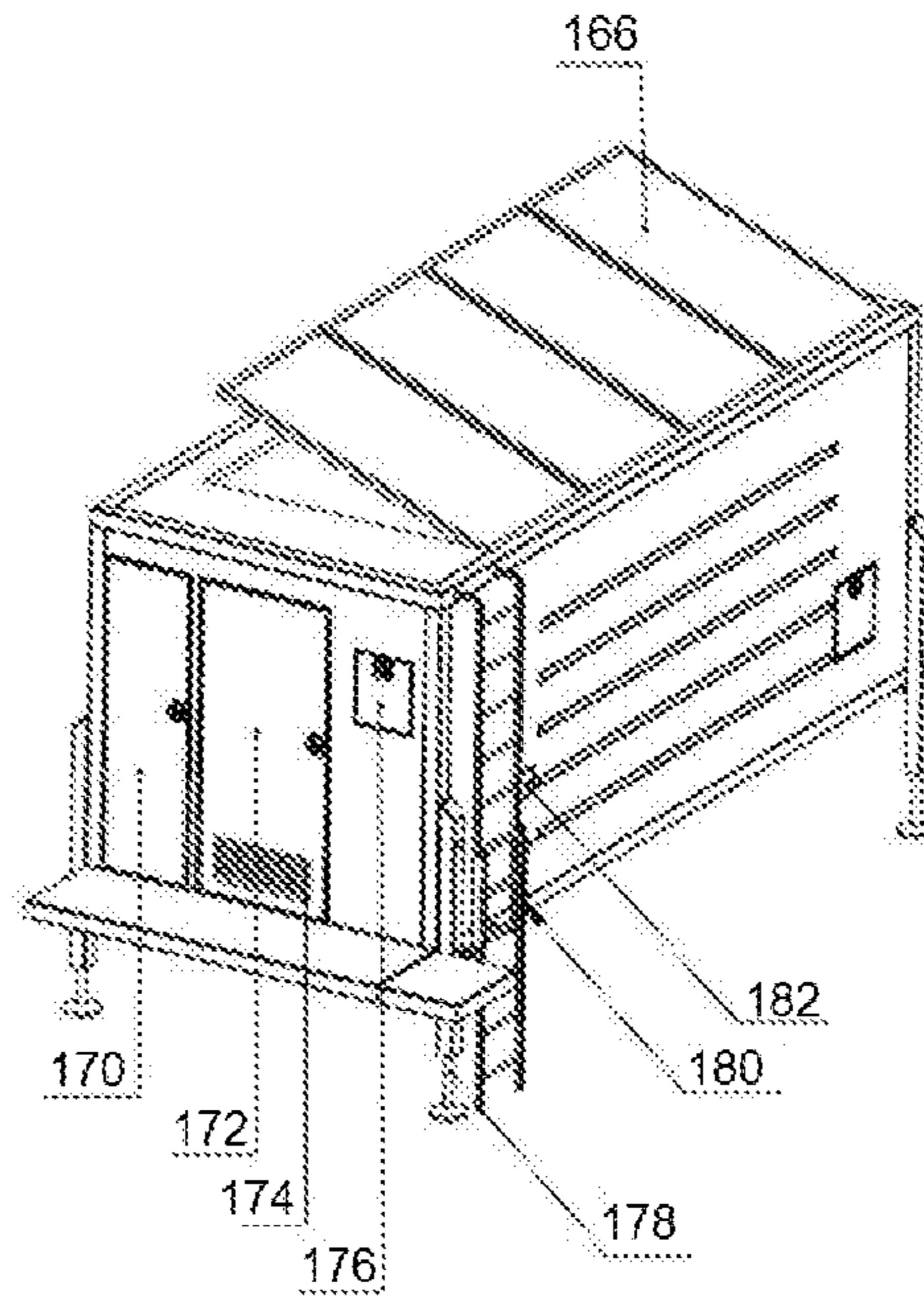

Fig. 17a

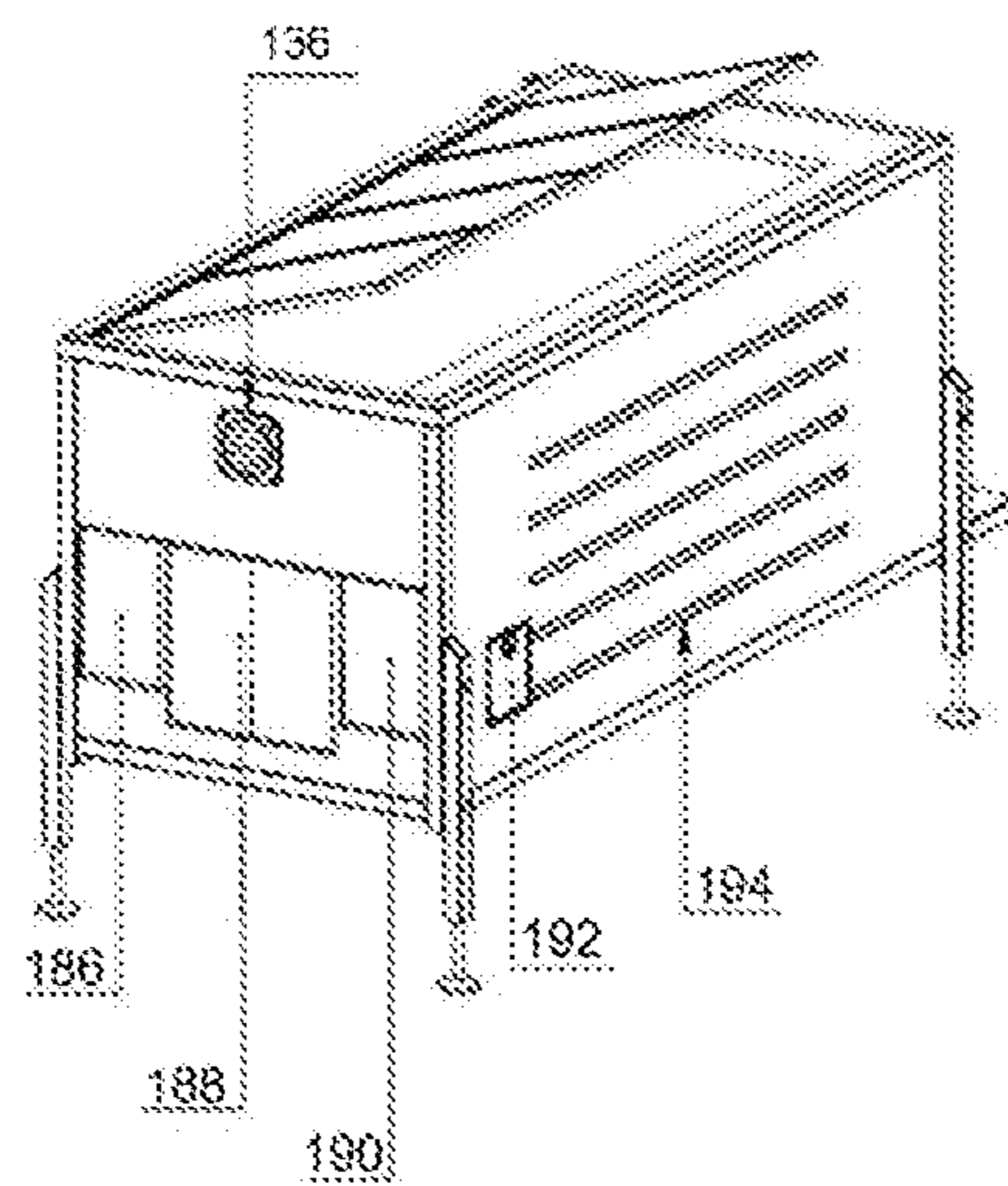

Fig. 17b

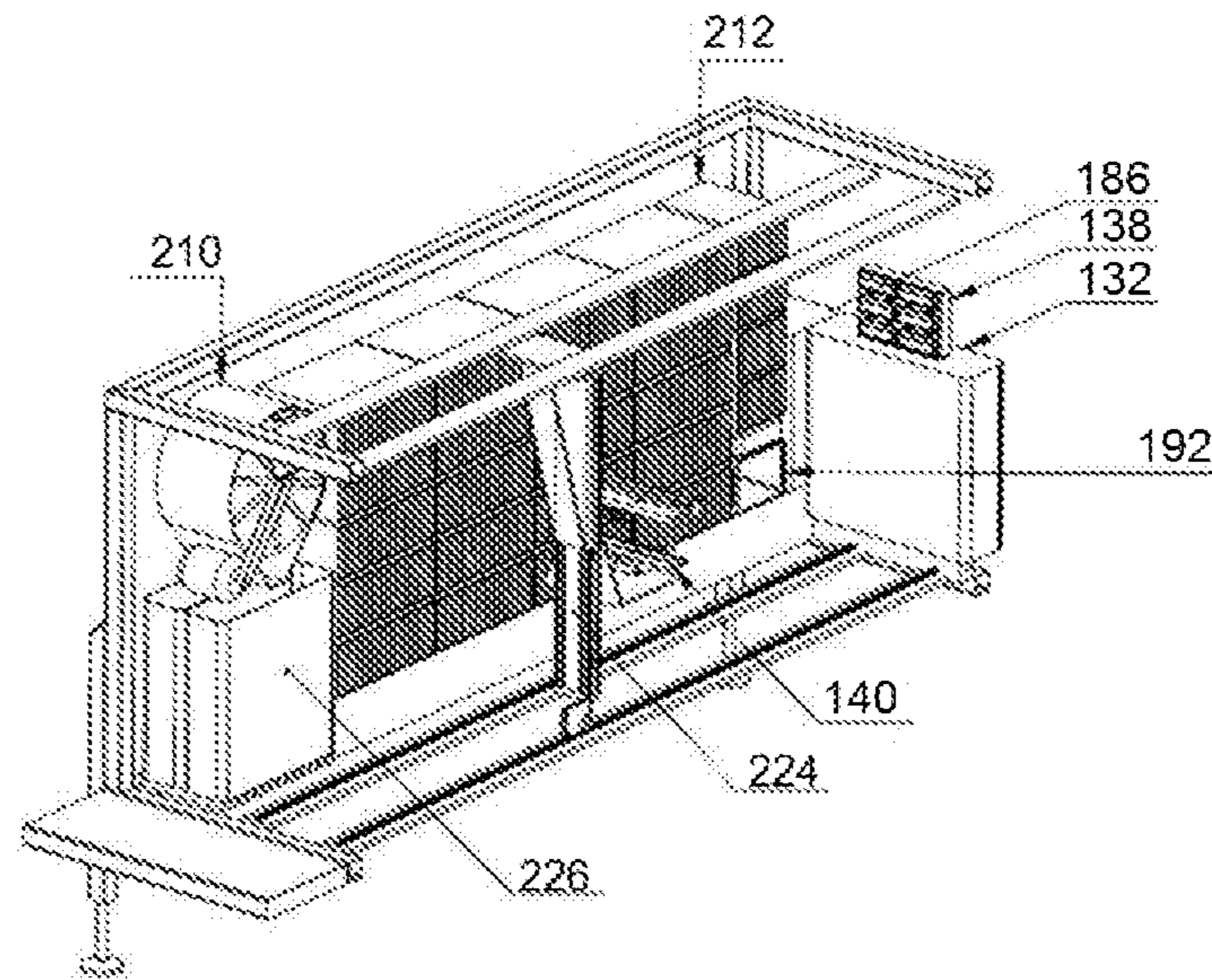

Fig. 18a

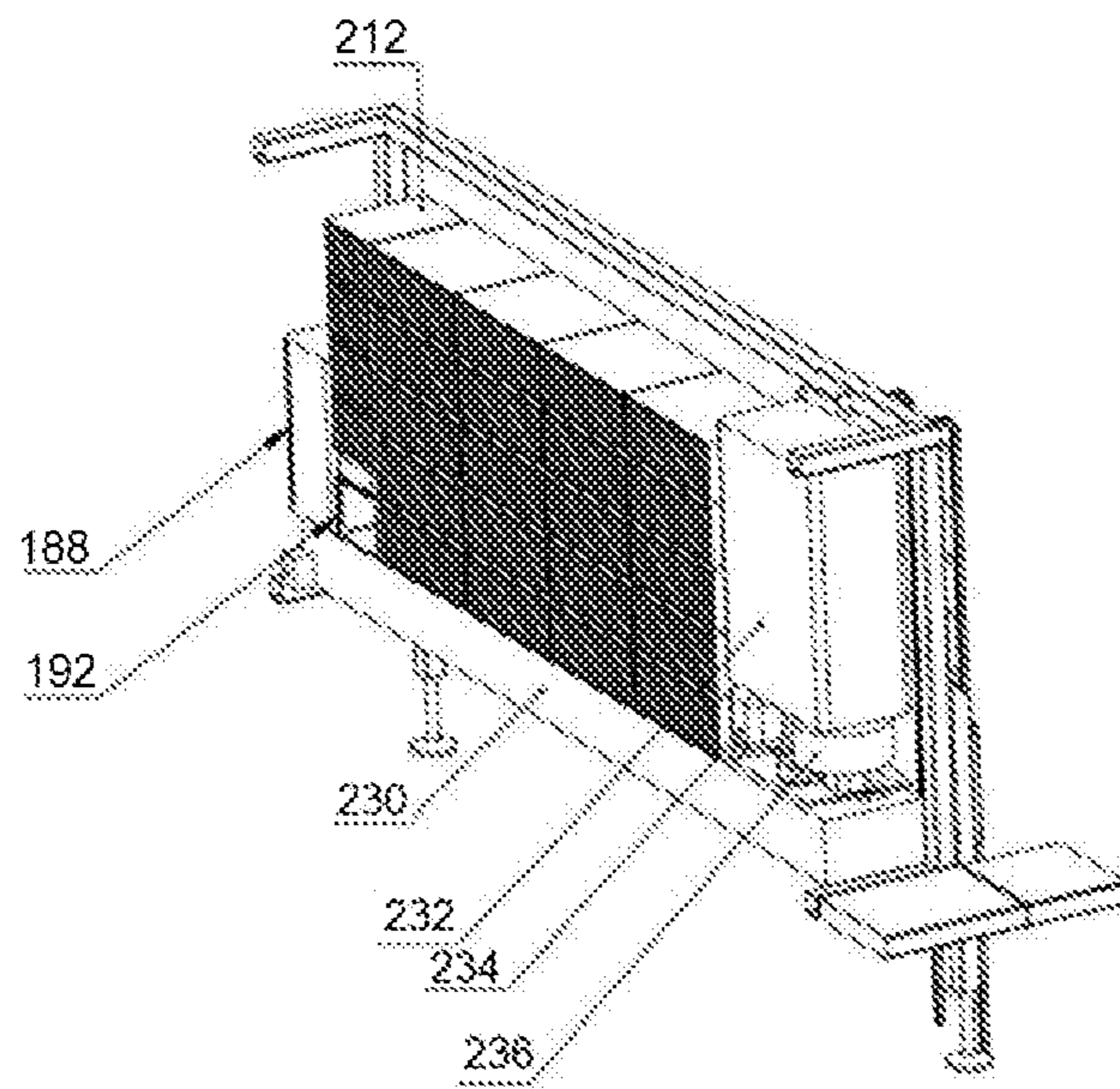

Fig. 18b

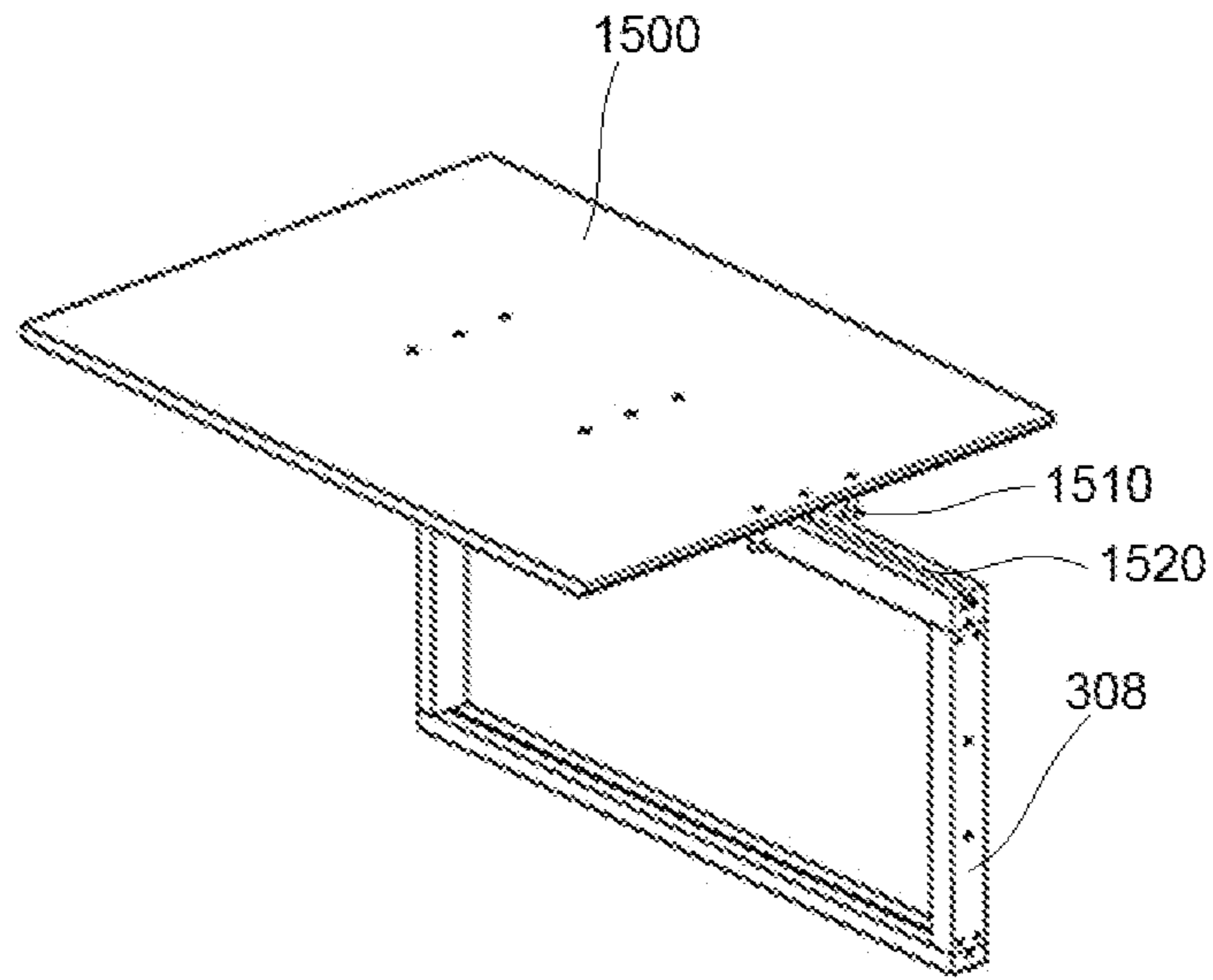

Fig. 19a

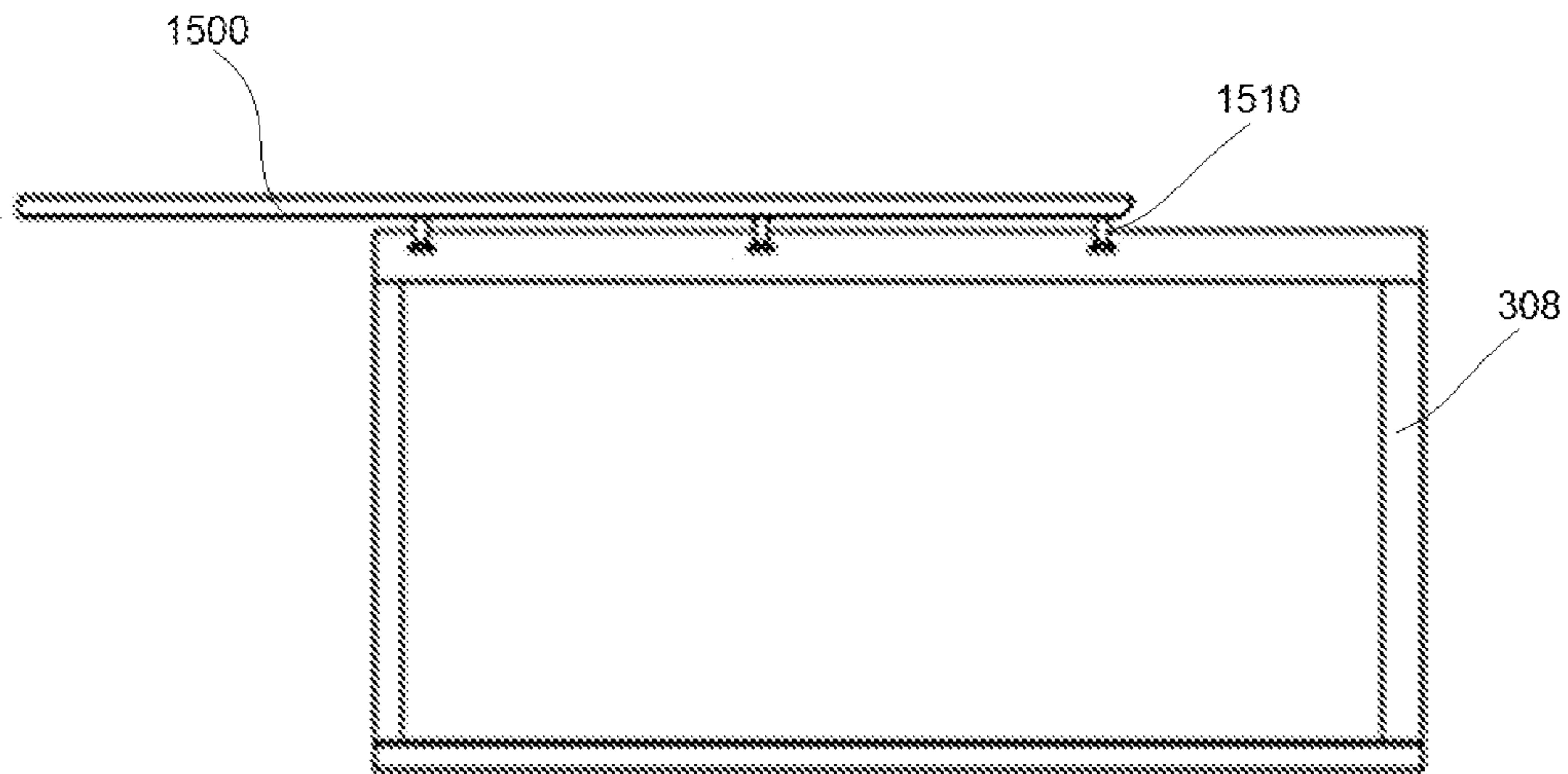

Fig. 19b

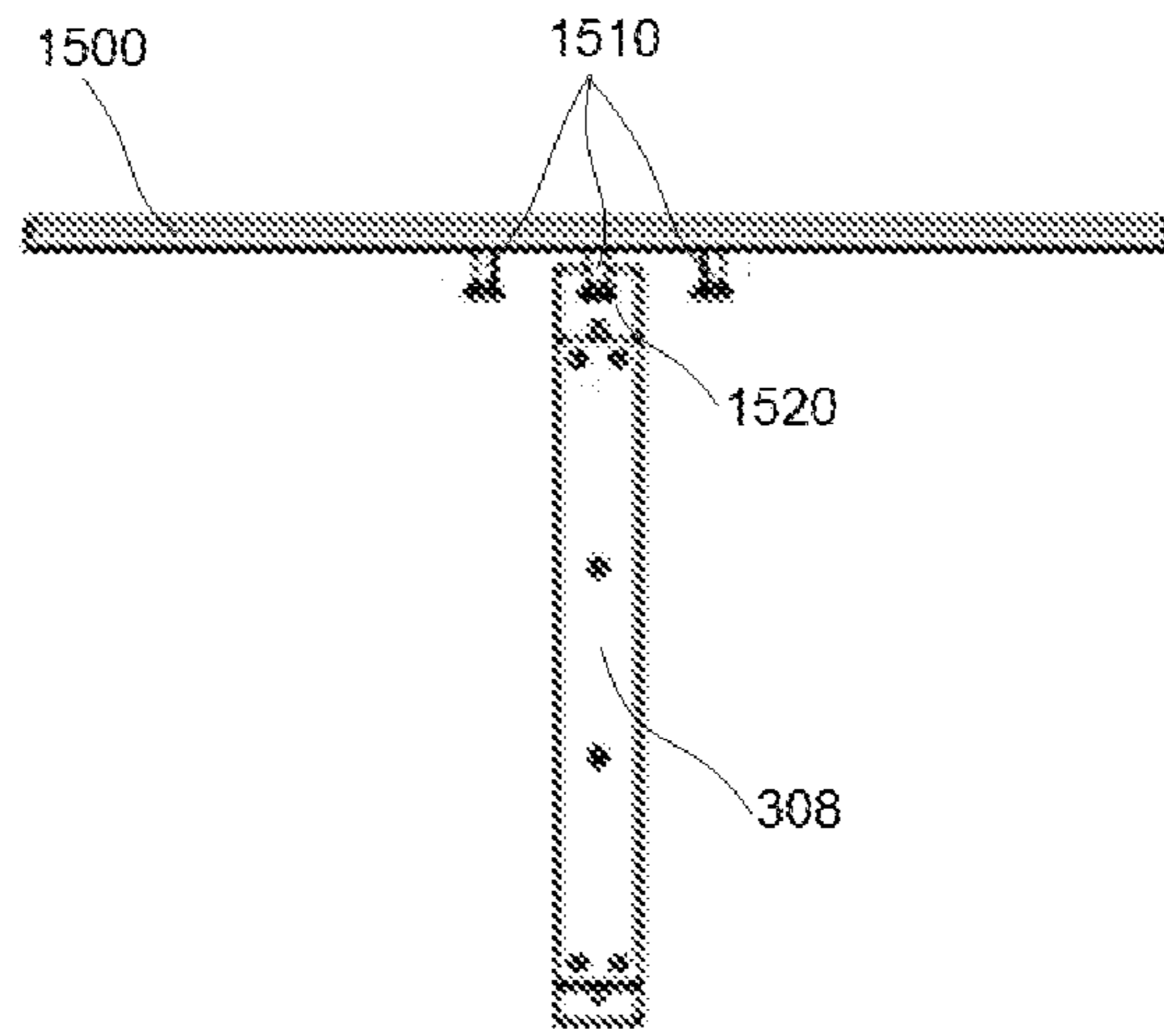

Fig. 19c

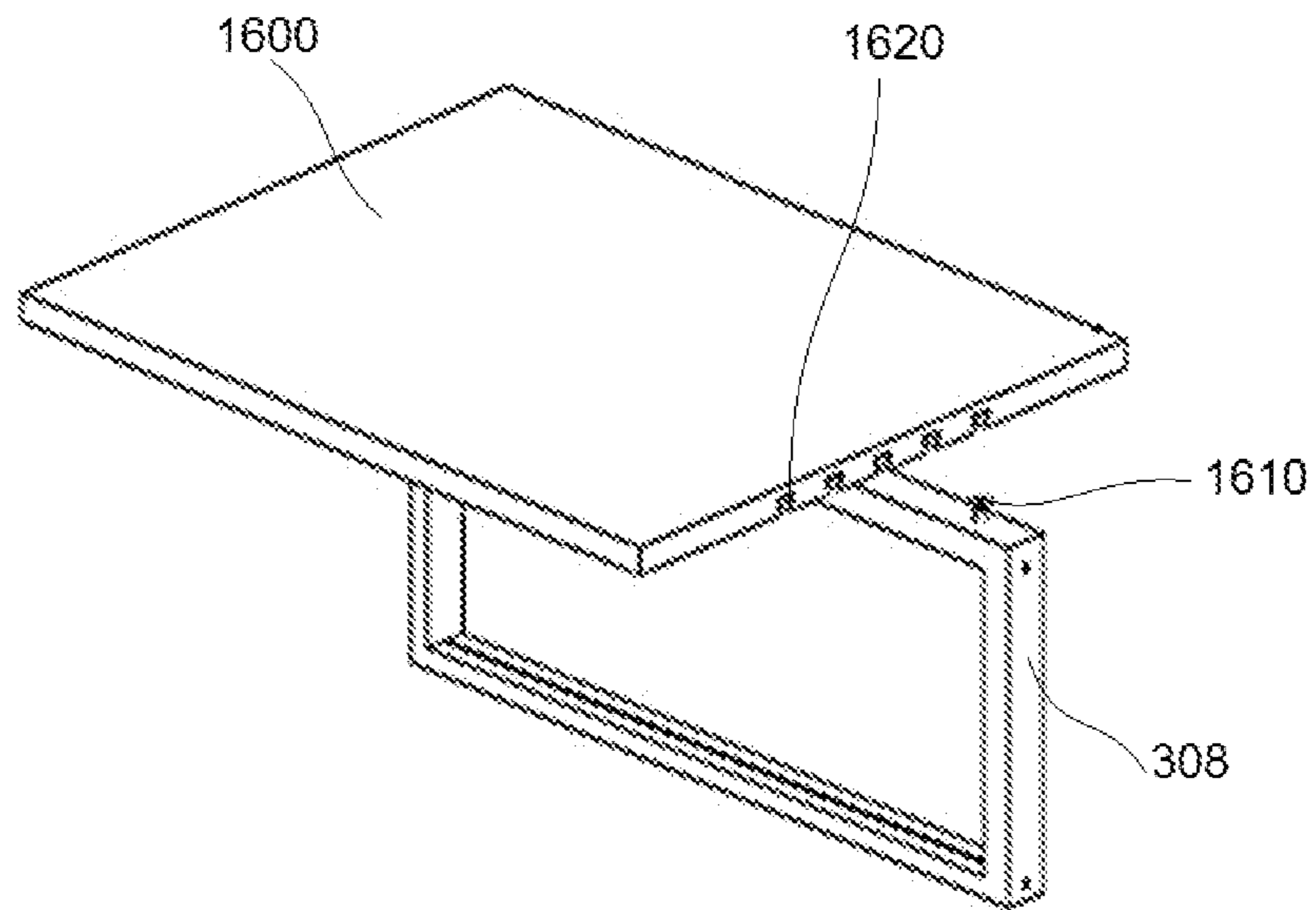

Fig. 20a

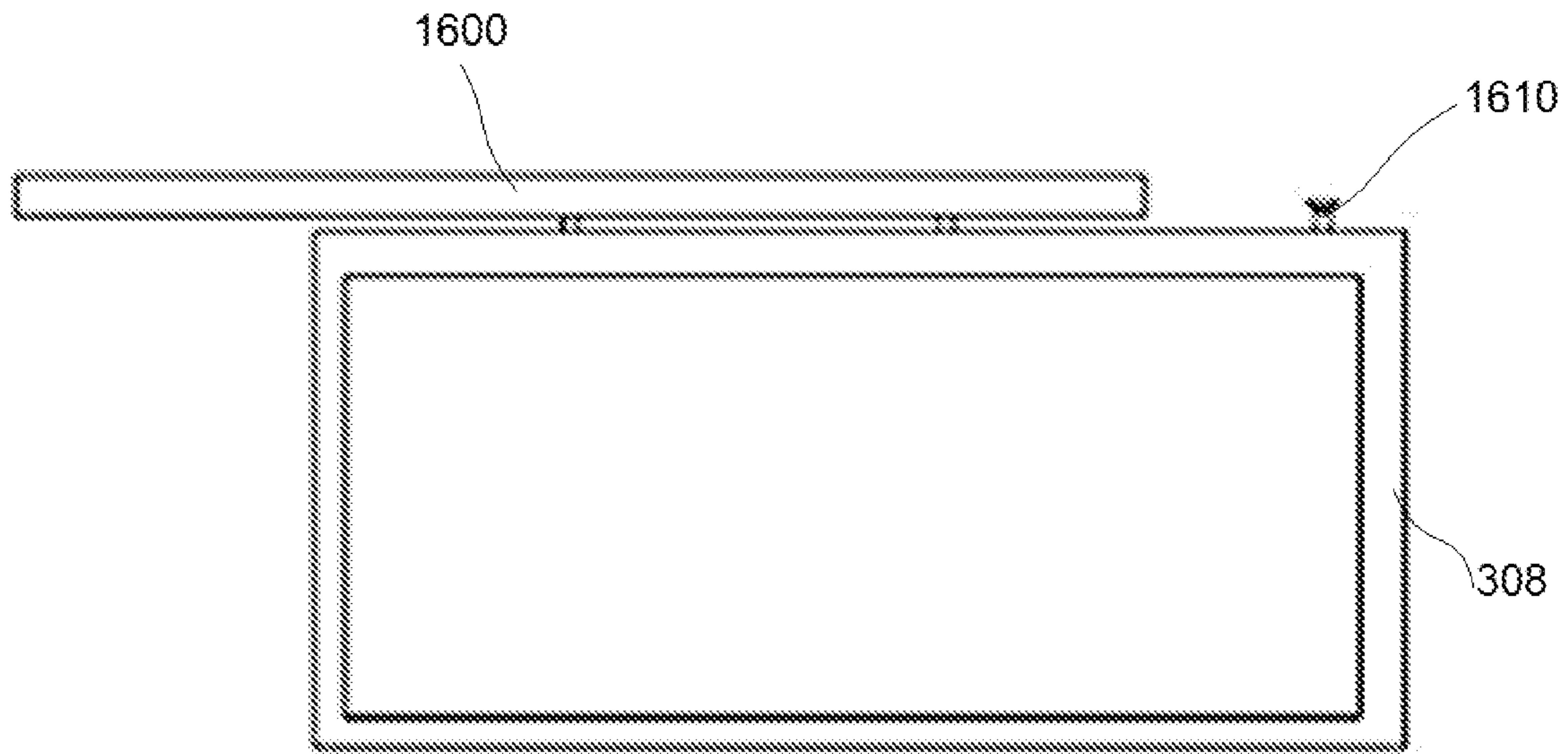

Fig. 20b

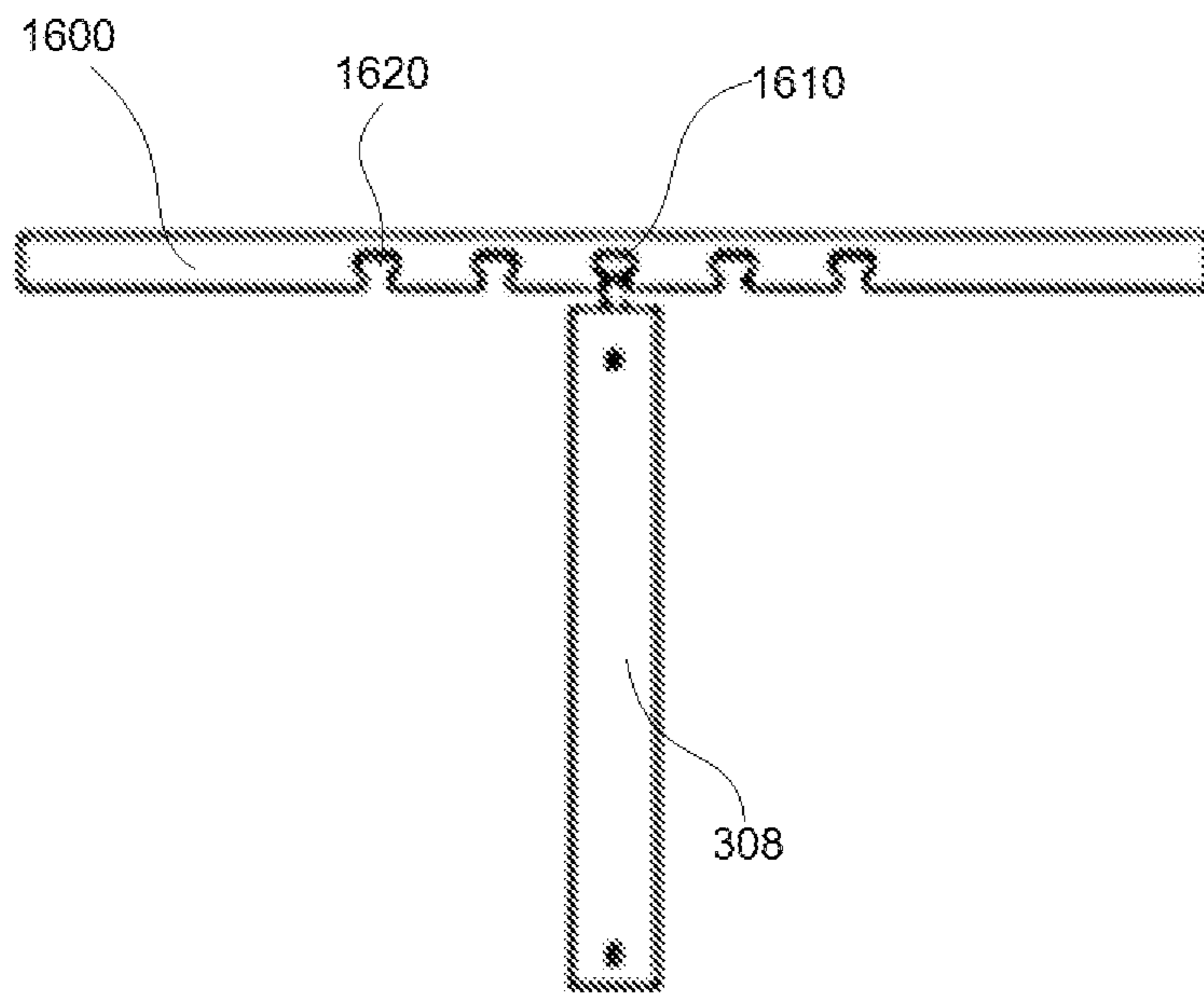

Fig. 20c

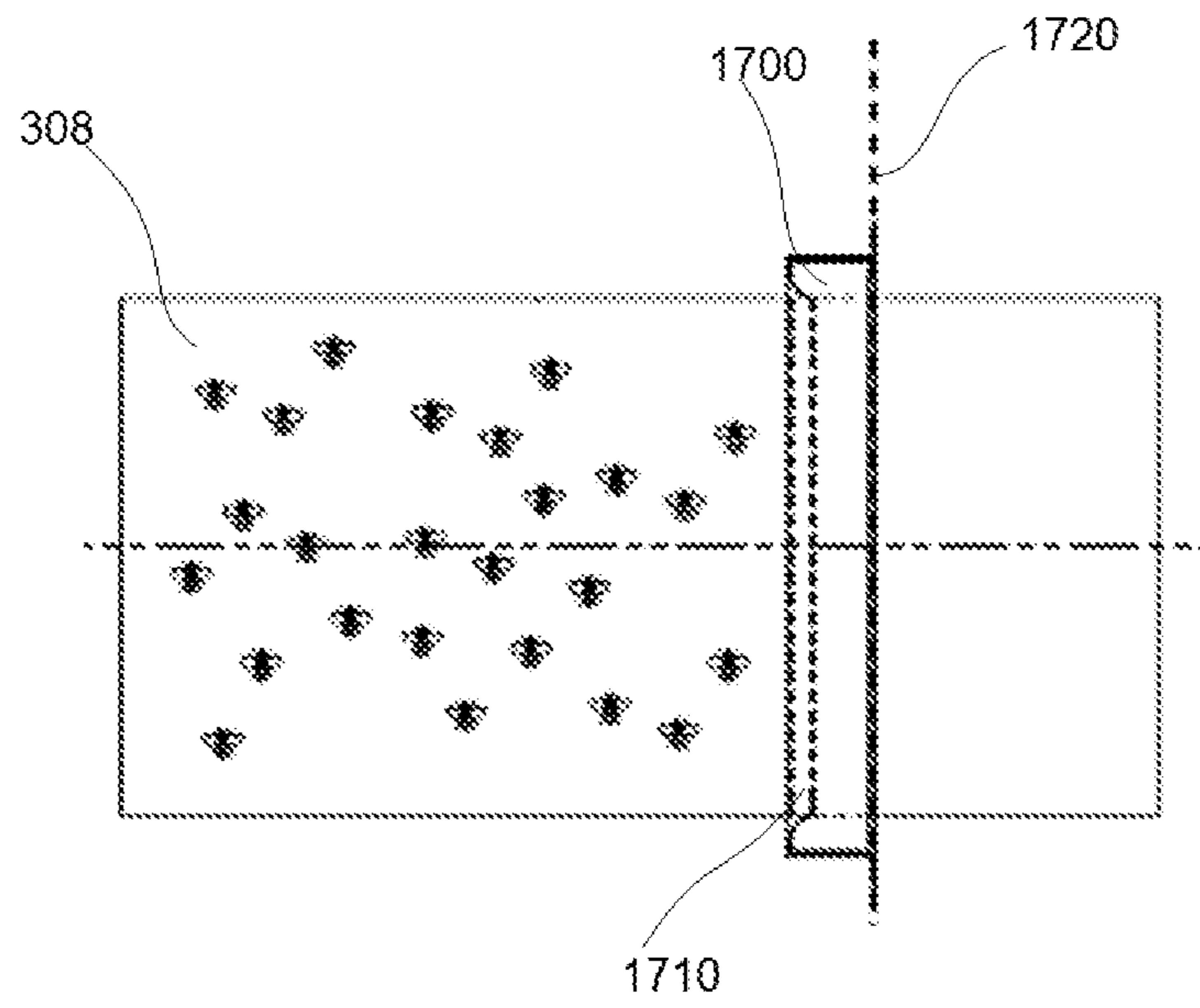

Fig. 21a

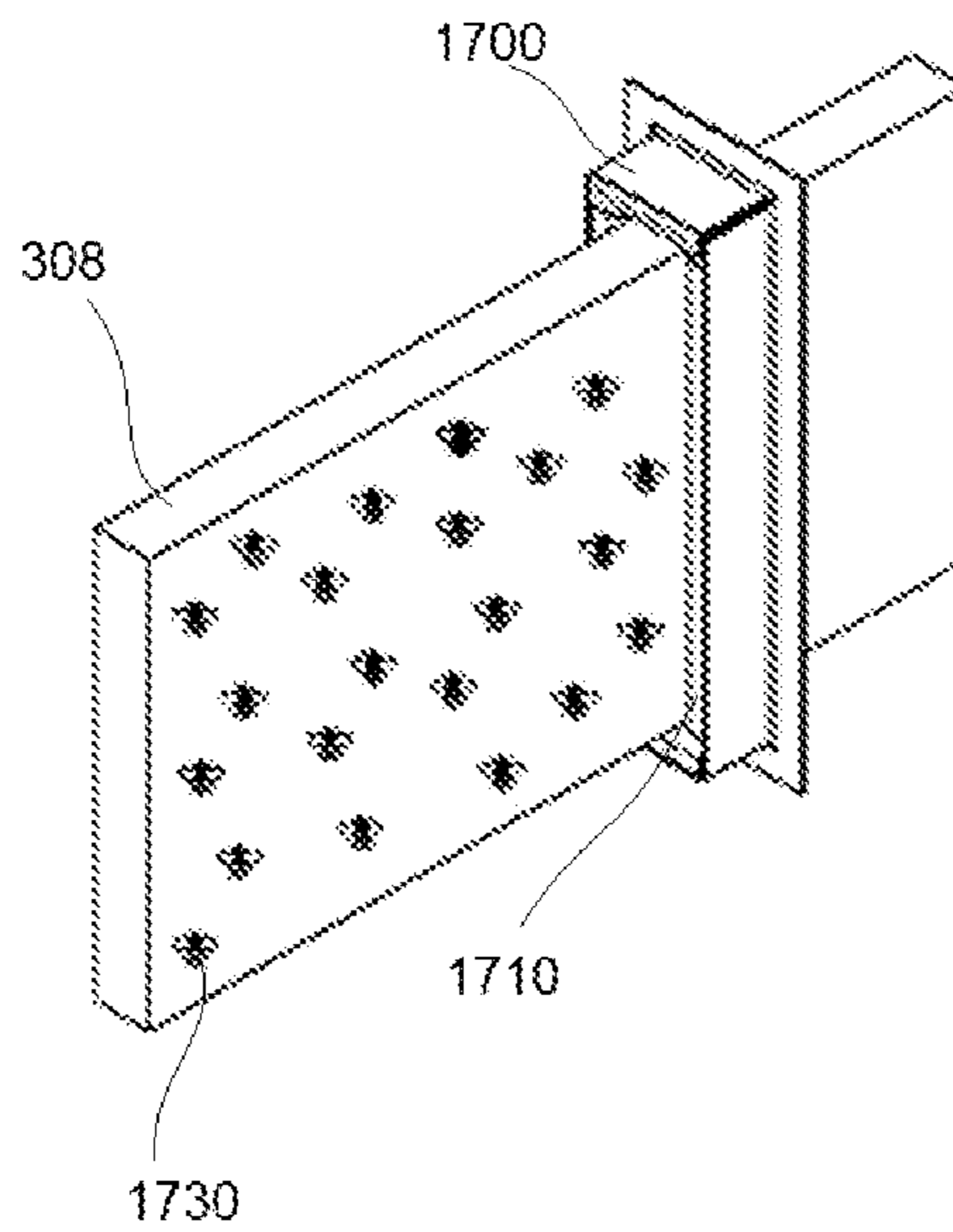

Fig. 21b

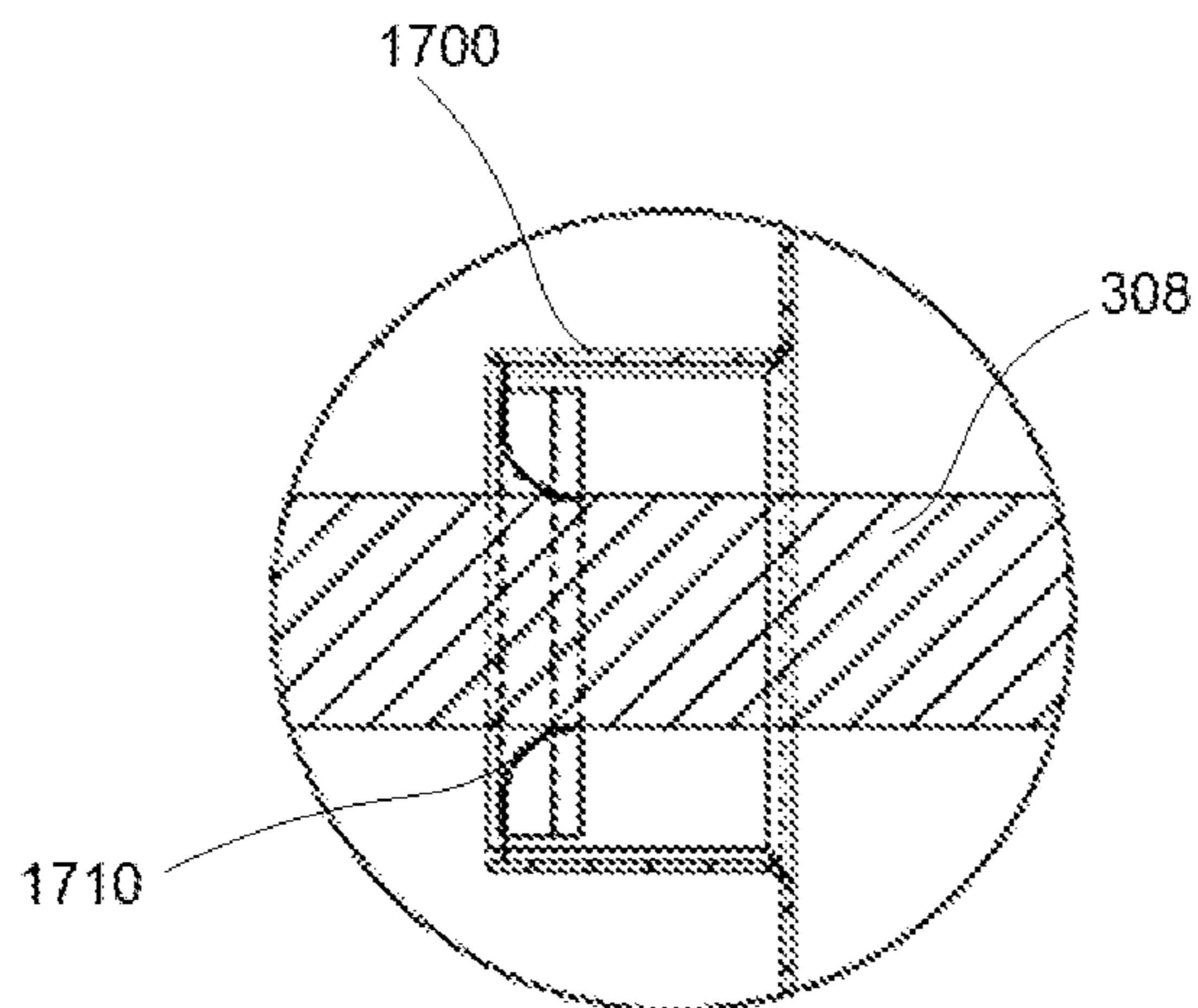

Fig. 21c

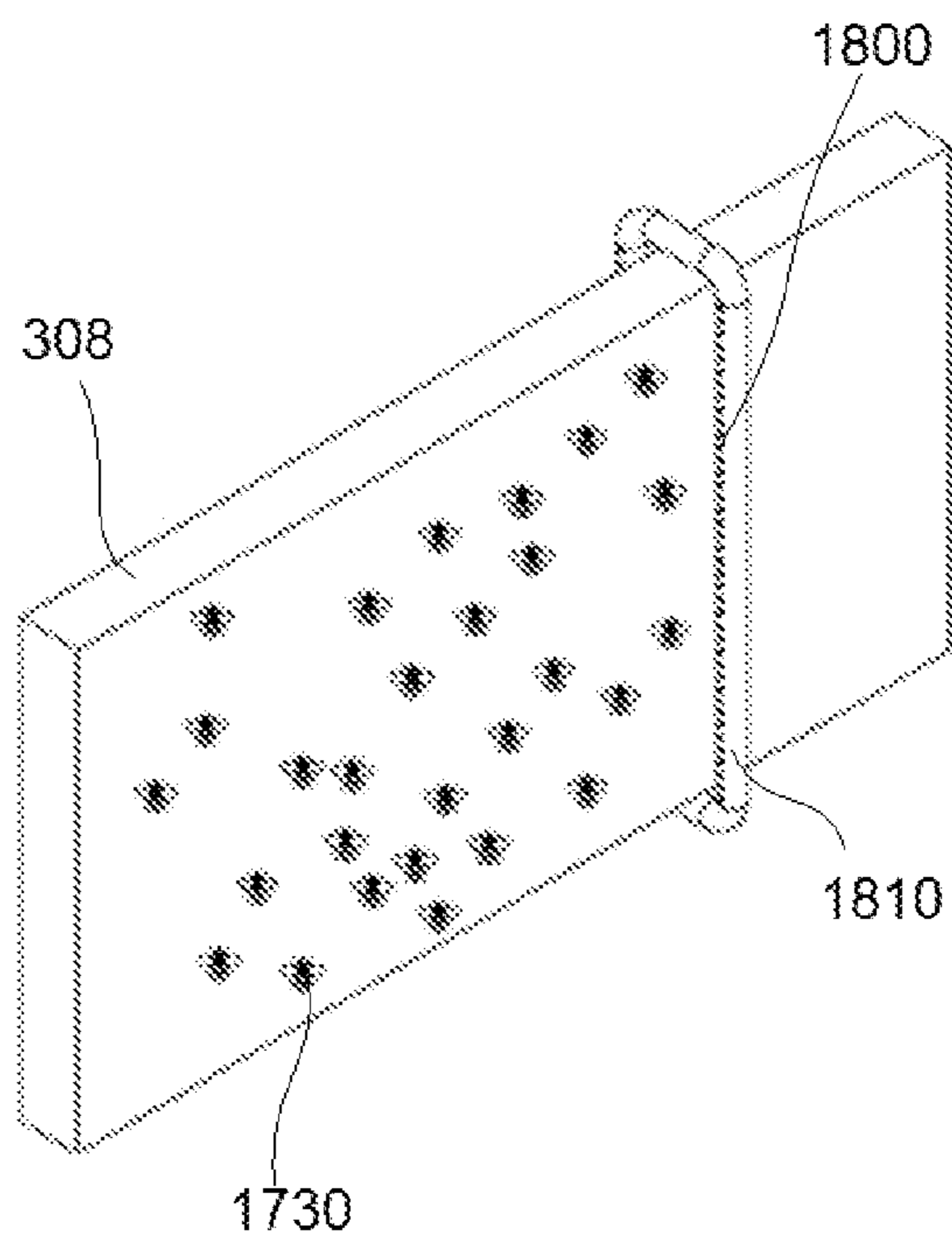

Fig. 22a

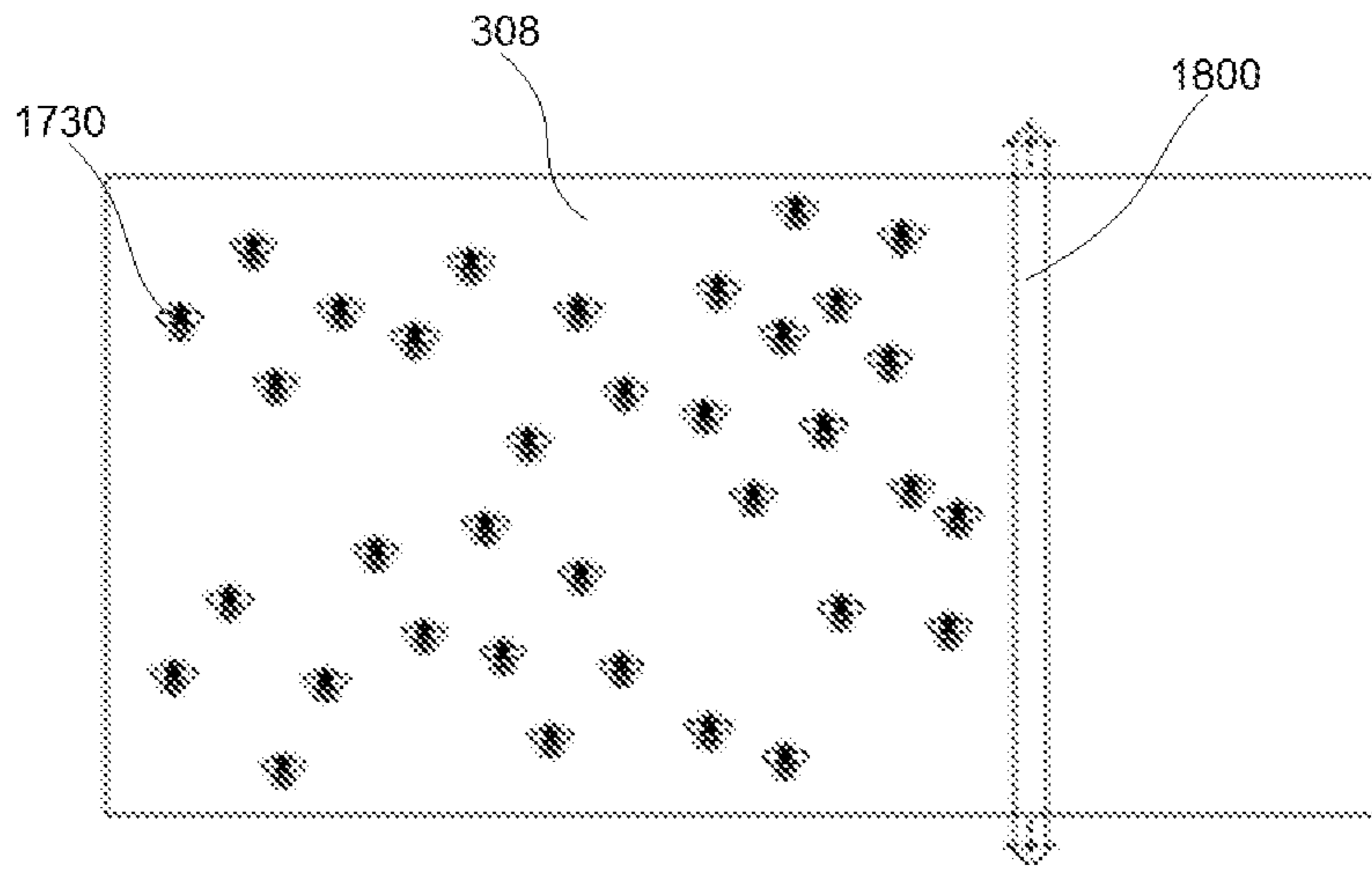

Fig. 22b

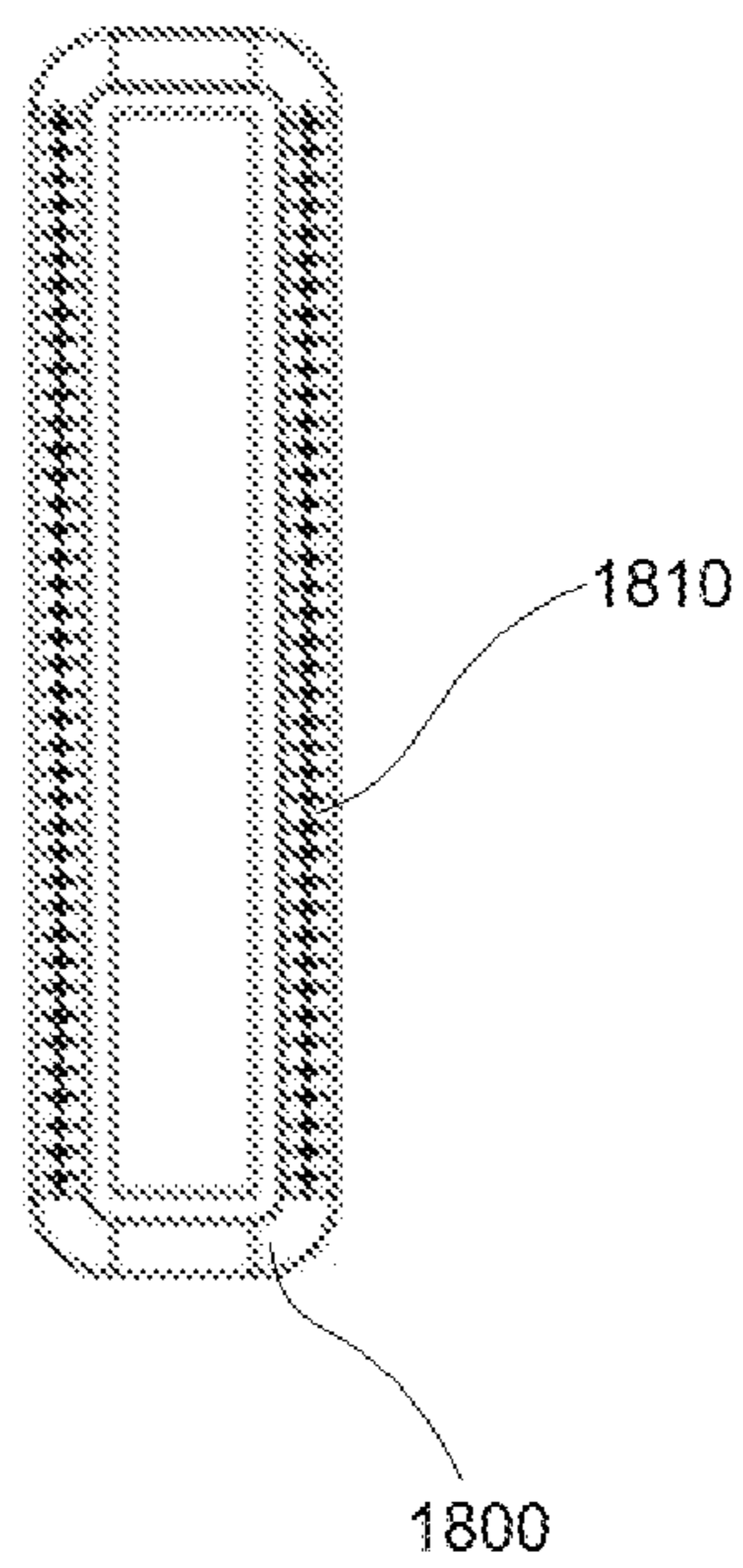

Fig. 22c

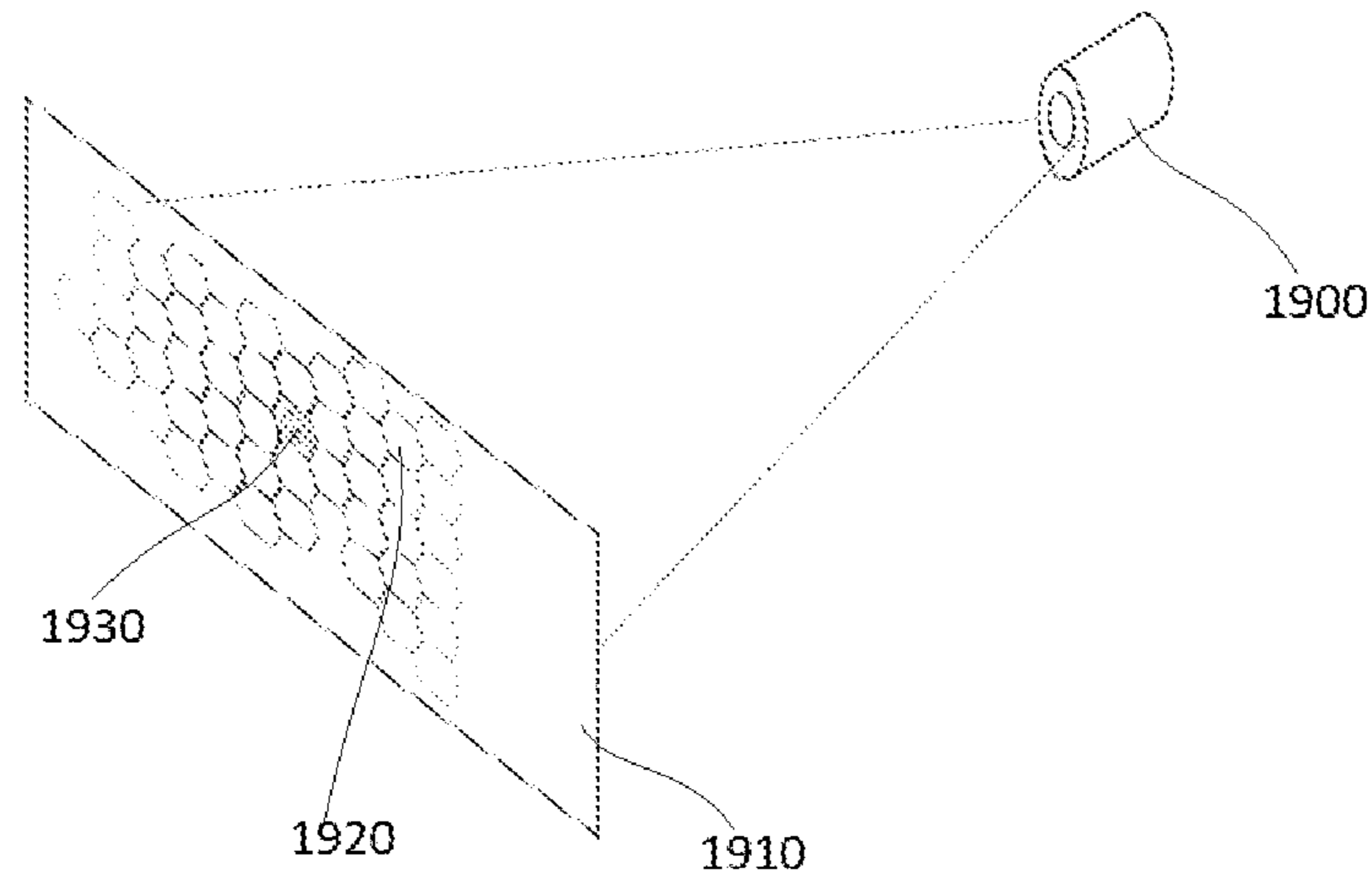

Fig. 23a

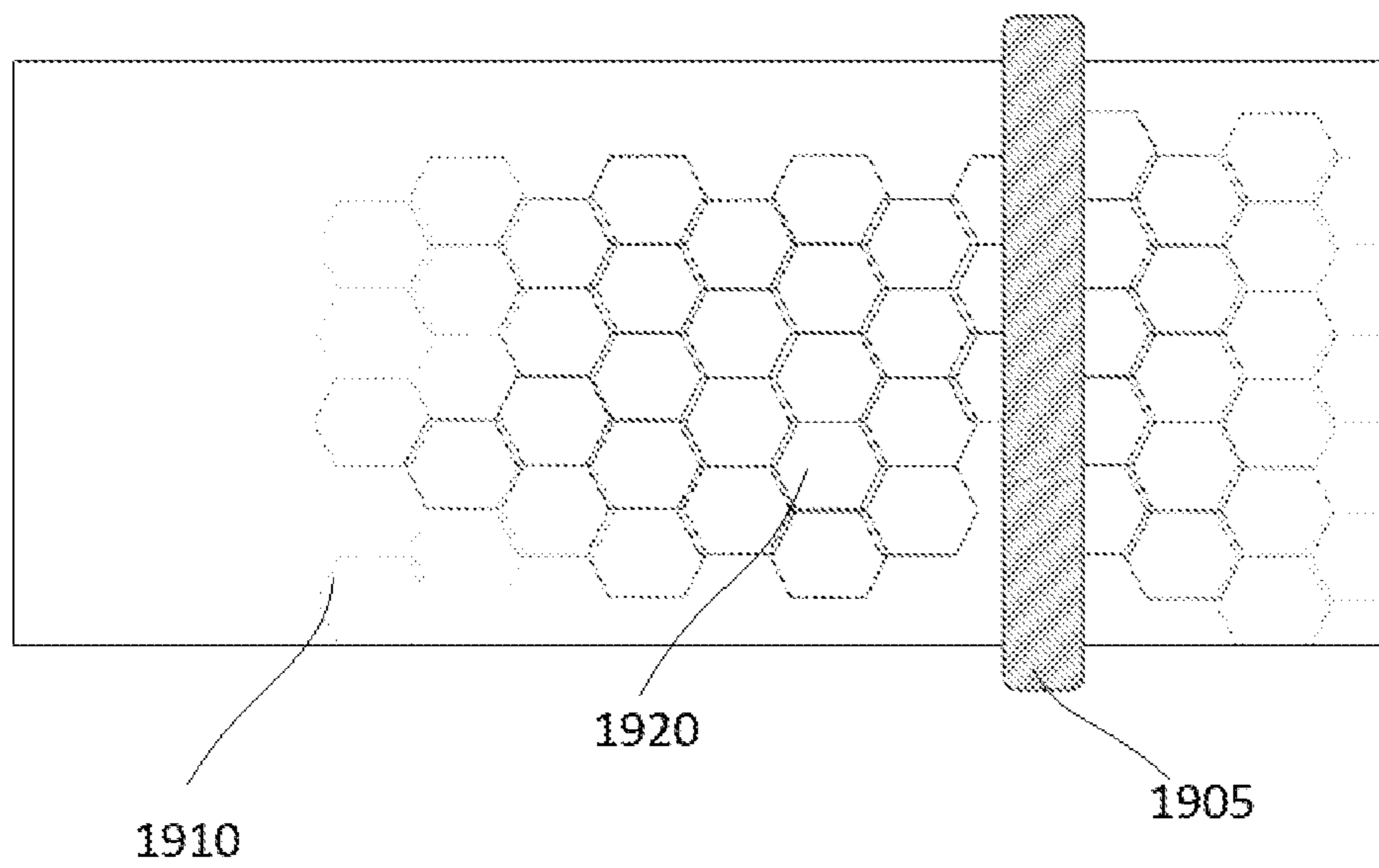

Fig. 23b

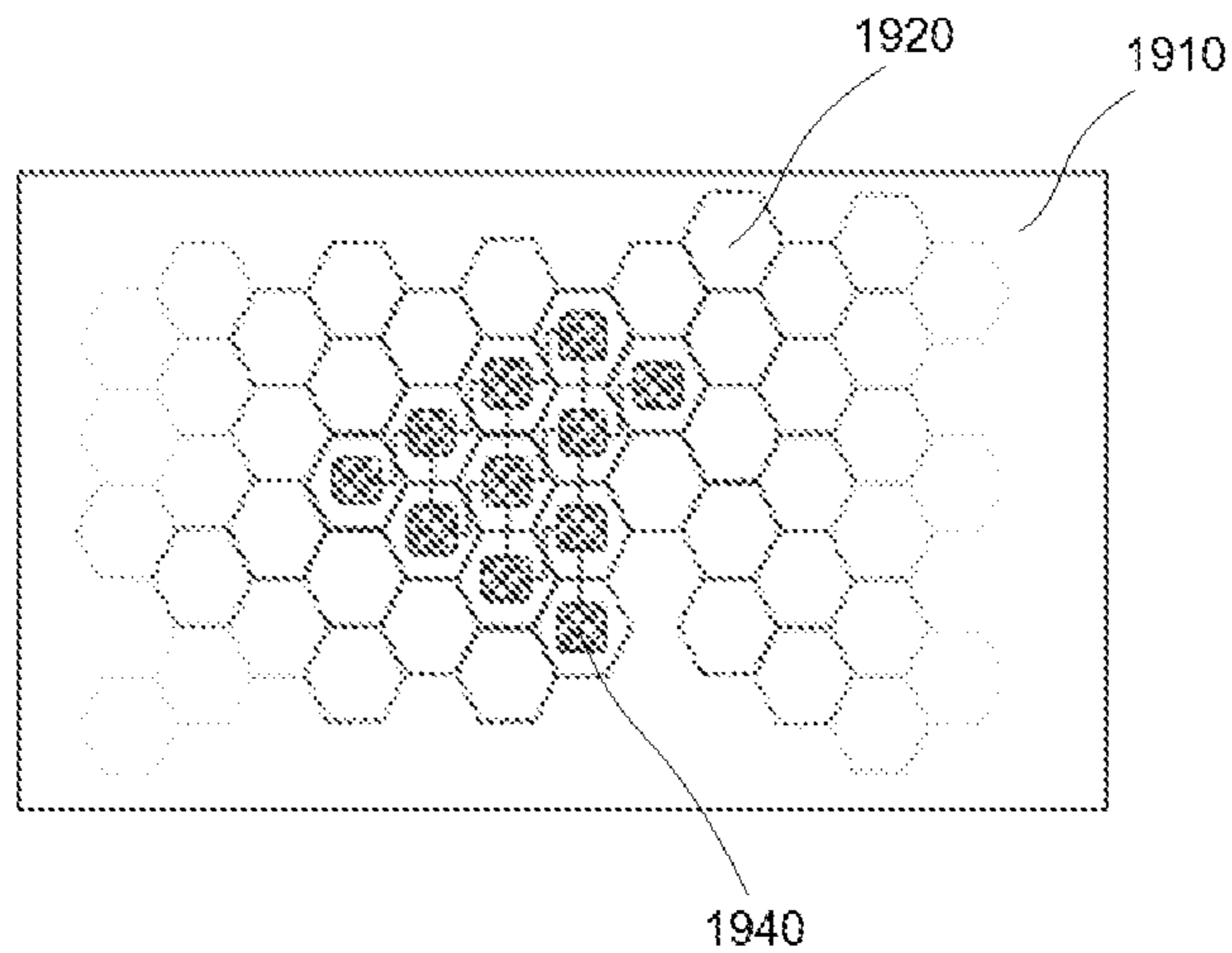

Fig. 23c

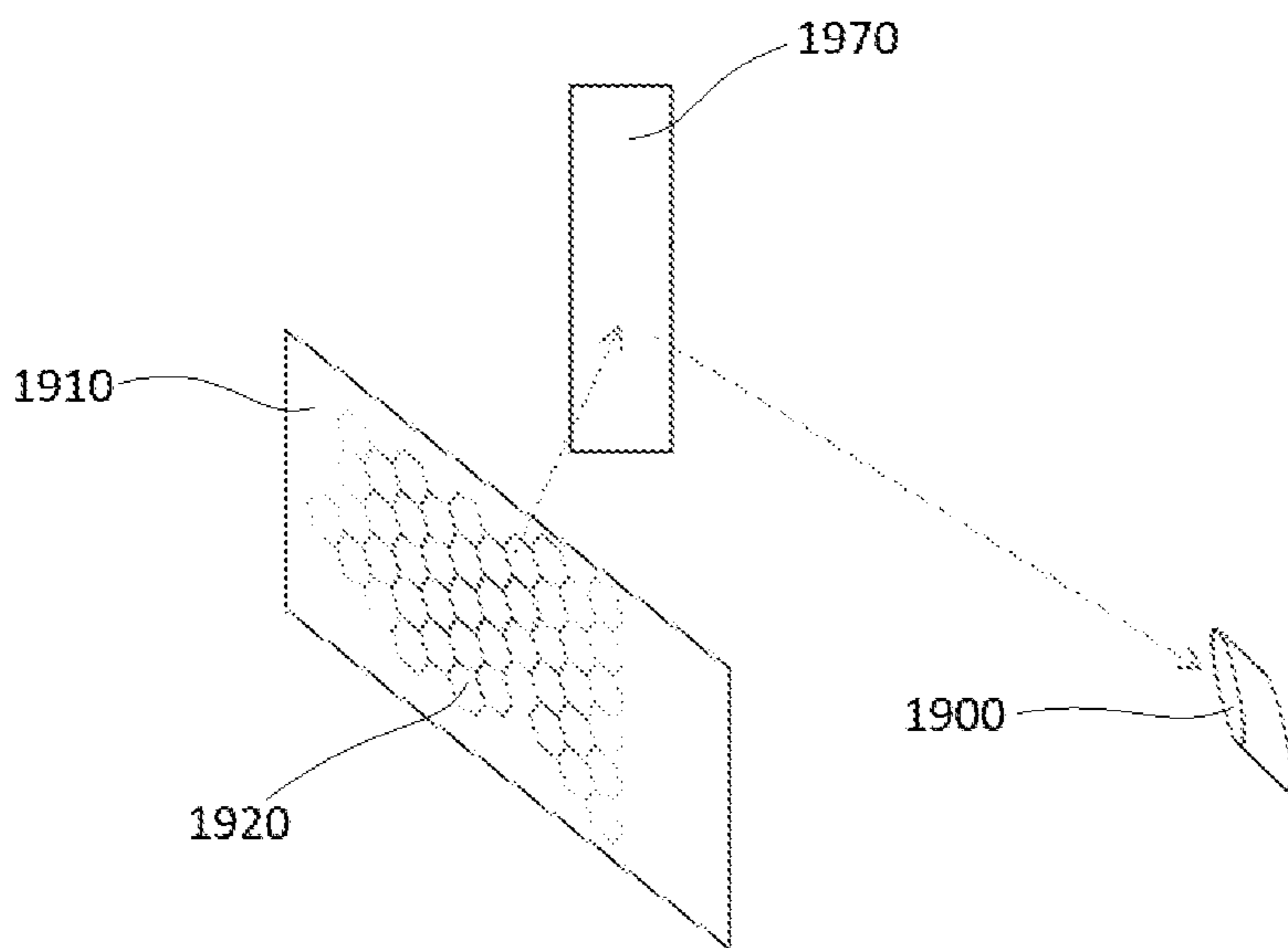

Fig. 23d

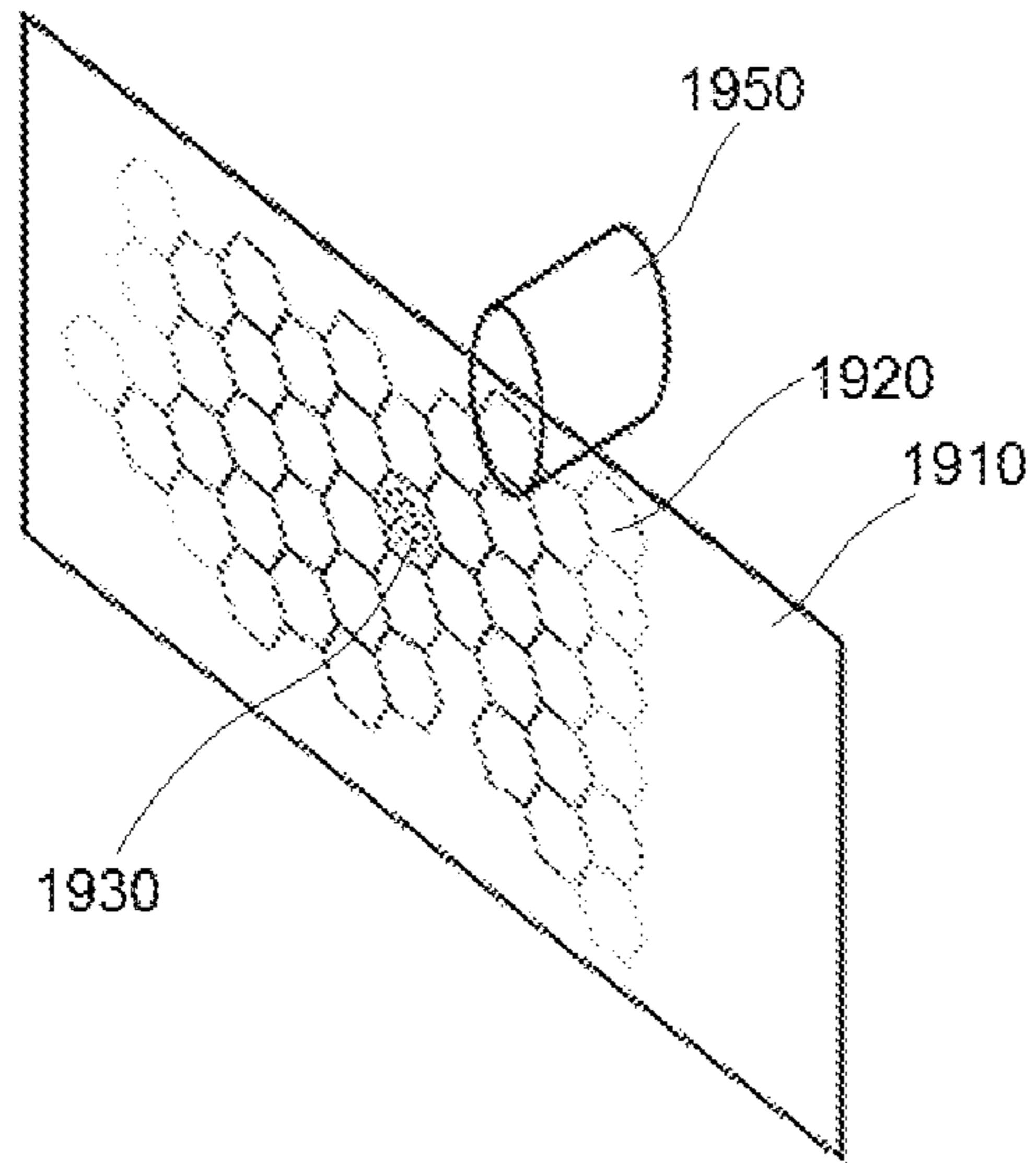

Fig. 24a

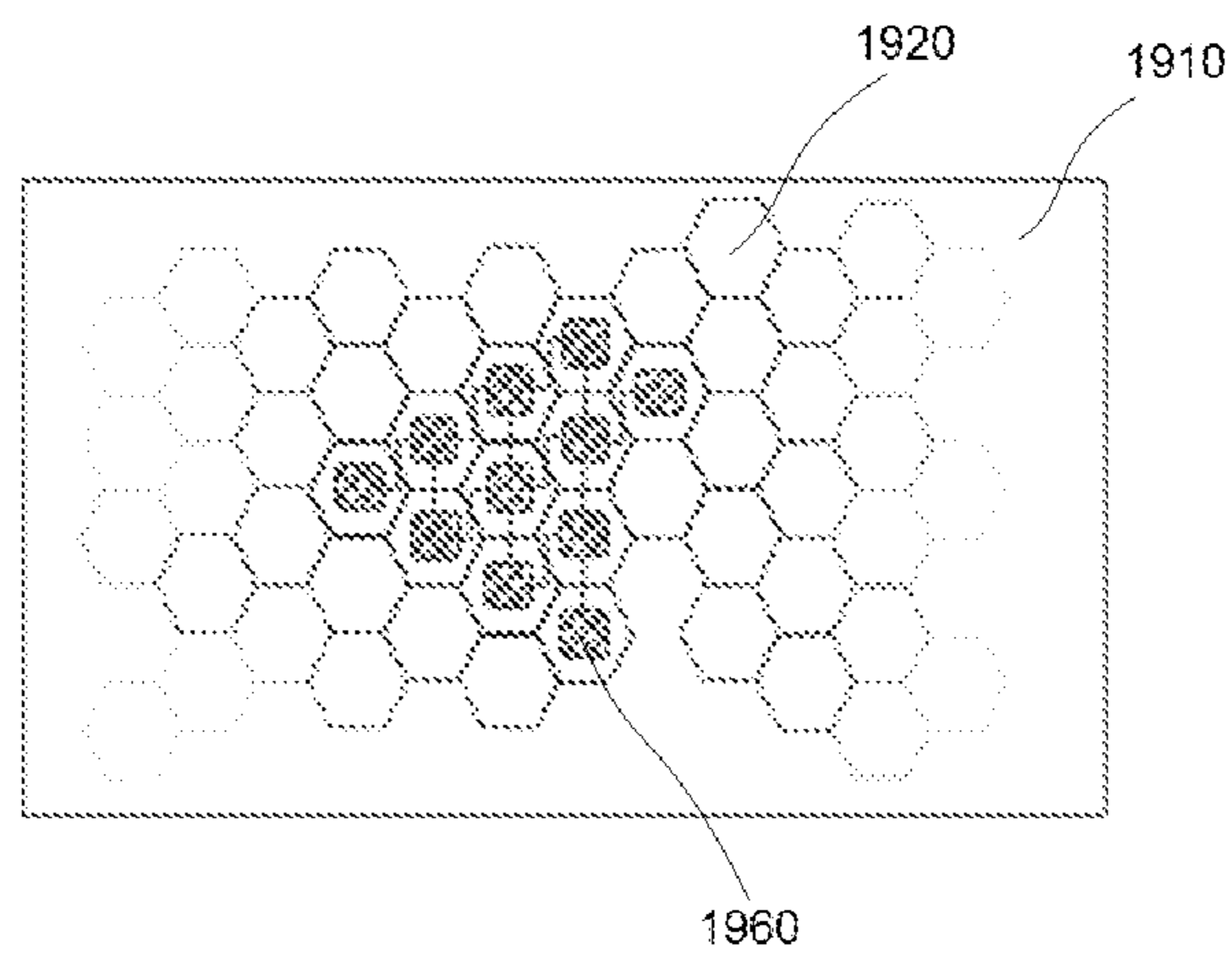

Fig. 24b

AUTONOMOUS BEEHIVES**CROSS-REFERENCES TO RELATED APPLICATIONS**

This application is a continuation of U.S. Ser. No. 16/872,769 filed on May 12, 2020; which was a continuation-in-part of PCT/IL2018/051223 filed on Nov. 13, 2018; which claims the benefit of priority of U.S. Provisional Application No. 62/584,952 filed on Nov. 13, 2017. U.S. Ser. No. 16/872,769 also claims the benefit of priority of U.S. Provisional Application Nos. 62/904,695; 62/904,699; 62/904,701 and 62/904,703 filed on Sep. 24, 2019. The contents of the above applications are all incorporated by reference as if fully set forth herein in their entireties.

TECHNICAL FIELD

The present disclosed subject matter relates to beehives. More particularly, the present disclosed subject matter relates to efficient automatic beehives.

Unless otherwise defined, all technical and scientific terms used herein have the same meaning as commonly understood by one of ordinary skill in the art to which this disclosed subject matter belongs. Although methods and materials similar or equivalent to those described herein can be used in the practice or testing of the present disclosed subject matter, suitable methods and materials are described below. In case of conflict, the specification, including definitions, will control. In addition, the materials, methods, and examples are illustrative only and not intended to be limiting.

BACKGROUND OF THE INVENTION

Beekeeping has barely changed in the past 150 years and is still based on traditional labor-intensive work practices which have not been modernized. Inadequate beekeeping methods combined with new pests and diseases have put apiaries in the face of high annual colony loss rates associated with the *Varroa* mite and Colony Collapse Disorder (CCD). Traditional work practices have become increasingly difficult and have had a strong negative effect on the profitability of beekeeping in the honey industry. An astonishing 70% of the honey sold at supermarkets as pure honey is not pure. This results from the lack of traceability in the honey production process.

The contribution of bees to agriculture is estimated at \$160B a year. Since the 1990's the rate of increase in pollination-based agriculture has sharply increased, surpassing the average increase in the number of hives. This situation in addition to the recent colony loss crises has created a severe shortage in bees for pollination. This has a very strong effect on the pollination market. In the US prices for pollination services have tripled over the past 15 years.

SUMMARY OF THE INVENTION

It is hence one object of the invention to disclose an automatic beehive for commercial beekeeping including honey production and pollination services. The aforesaid automatic beehive comprises: (a) a plurality of honeycomb brood frames and other frames in the hive releasably mounted within at least one hive chamber; (b) a mechanism for removing all kind of bee frames such as honeycomb or brood frames and other types of frames from said hive chamber and inserting said bee frames thereinto; (c) an

automated honey harvesting arrangement; (d) an arrangement for monitoring hive and bees conditions, analyzing obtained data and reporting results to a user; and (e) an arrangement for feeding bees, pest and climate control. (f)
5 An AI based decision making algorithm based on data gathered from the hives which will alert the user suggest and perform beekeeping practices within the unit in an automatic manner.

It is a core purpose of the invention to provide the mechanism for removing and inserting said bee frames (all kind of frames in the hive) comprising a frame loader linearly displaceable along said at least one hive chamber.

Another object of the invention is to disclose the frame loader displaceable along at least one main rail oriented in parallel to a face of hive chamber.

A further object of the invention is to disclose the frame loader driven by a motor.

A further object of the invention is to disclose the frame loader comprising a mechanism configured for releasably gripping said bee frames therewithin.

A further object of the invention is to disclose the mechanism is a gripper.

A further object of the invention is to disclose the frame loader linearly displaceable perpendicular to said face of said at least one hive chamber such that each honey frame in said hive chamber is removable from and insertable into said at least one hive chamber.

A further object of the invention is to disclose the frame loader comprising at least one loader rail oriented perpendicular to said face of said at least one hive chamber and a ball-screw linear actuator configured for removing and inserting said bee frame gripped within said frame loader.

A further object of the invention is to disclose the frame loader comprising a loader mechanism configured for directing said bee frames during removing and inserting thereof.

A further object of the invention is to disclose the honey harvesting arrangement comprising at least one sensor configured for monitoring said honeycombs to be harvested.

A further object of the invention is to disclose the honey harvesting arrangement comprising a centrifuge honey extractor.

A further object of the invention is to disclose a mechanism for controlling the size of the opening of the hives used for bees in order to exit and enter the hive in order to collect pollen, nectar etc., based on a mechanical arrangement for enlarging and diminishing the opening automatically operated by the unit.

A further object of the invention is to disclose the arrangement for monitoring hive and bees conditions, analyzing obtained data and reporting results to a user comprising optical means selected from the group consisting of a camera, a scanner, a mirror configured for forming images of said honeycomb and brood frames and a light source for illumination of said honeycomb and brood frames.

A further object of the invention is to disclose the arrangement for feeding bees, pest and climate control comprising a sugar tank, a water tank, a pesticide tank, a sugar solution mixer, and a dispenser of an obtained solution.

A further object of the invention is to disclose the arrangement for feeding bees, pest and climate control comprising an air conditioning system.

A further object of the invention is to disclose the arrangement for monitoring bees conditions, analyzing obtained data and reporting results to a user comprising at least one sensor and artificial intelligence unit configured for classifying current well-being of said hive chambers hives inside the automatic beehive.

A further object of the invention is to disclose the at least one sensor and artificial intelligence unit configured for obtaining metrics of said well-being of said hive chambers, making beekeeping decisions and predicting failure modes of said beehive.

A further object of the invention is to disclose a method of producing honey comprising steps of: (a) providing an automatic system for maintaining bees; said automatic beehive comprising: (i) a plurality of honeycomb and brood frames releasably mounted within at least one hive chamber; (ii) a mechanism for removing said bee frames from said hive chamber and inserting said bee frames thereinto; (iii) an automated honey harvesting arrangement; (iv) an arrangement for monitoring hive and bees conditions, analyzing obtained data and reporting results to a user; and (v) an arrangement for feeding bees, pest and climate control; said mechanism for removing and inserting said bee frames comprises a frame loader linearly displaceable along said at least one hive chamber; (b) providing honey bees; (c) maintaining internal climate conditions effective for honey production; (d) monitoring hive and bees conditions; (e) analyzing obtained data; (f) breeding said honey bees; (g) reporting analyzed data to a user; (h) harvesting honey.

It is another core purpose of the invention to provide the method comprising steps of removing and inserting said bee frames performed by a frame loader linearly displaceable along said at least one hive chamber.

A further object of the invention is to disclose a beehive for commercial or recreational beekeeping comprising honey production and pollination services; said beehive comprises: (a) a plurality of bee frames releasably mounted within at least one hive chamber; and (b) an arrangement for releasably securing said bee frames within said hive chamber.

It is a core purpose of the invention to provide the arrangement for hanging and releasably securing said bee frames comprises a base plate, a plurality of t-head connecting elements and a plurality of t-slots; said plurality of t-head connecting elements is releasably receivable within said plurality of t-slots.

Another object of the invention is to disclose the plurality of t-head connecting elements are secured to said base plate and arranged such that said bee frames provided with said t-slots are hangable to said base plate.

A further object of the invention is to disclose the plurality of said base plate provided with said plurality of t-slots. The bee frames are provided with said t-head connecting elements such that said bee frames are hangable to said base plate.

A further object of the invention is to disclose the beehive comprising at least one arrangement selected from the group consisting of: (a) an automated honey harvesting arrangement; (b) an arrangement for monitoring bees conditions, analyzing obtained data and reporting results to a user; and (c) an arrangement for feeding bees, pest and climate control.

A further object of the invention is to disclose beehive for commercial or recreational beekeeping comprising honey production and pollination services. The aforesaid beehive comprises: (a) a plurality of bee frames releasably mounted within at least one hive chamber; and (b) an arrangement for removing said bee frames from said hive chamber and inserting said bee frames thereinto;

It is a core purpose of the invention to provide said arrangement for removing and inserting said bee frames comprising bee-barriers members configured for individually embracing said bee frames such that each bee frame

passes through said bee-barrier member while bees maintained within said beehive are prevented from escaping from said beehive during replacement of said frames. Each of said bee-barrier member is provided with means for removing bees from said bee frames during removing thereof from said beehive.

Another object of the invention is to disclose the said means for removing bees from said bee frames comprising a member selected from the group consisting of a brush, a blade, a comb, a scrubber and any combination thereof.

A further object of the invention is to disclose the means for removing bees from said bee frames comprising air passages fluidly connectable to a source of compressed air configured for blowing off bees from said bee frames during removing thereof.

A further object of the invention is to disclose the means for removing bees from said bee frames comprising a heater configured for thermally repelling bees from said bee frames during removing thereof.

A further object of the invention is to disclose an automatic beehive for commercial beekeeping including honey production and pollination services. The aforesaid automatic beehive comprises: (a) a plurality of honeycomb brood frames and other frames in the hive releasably mounted within at least one hive chamber; (b) a mechanism for removing all kind of bee frames such as honeycomb or brood frames and other types of frames from said hive chamber and inserting said bee frames thereinto; (c) an automated honey harvesting arrangement; (d) an arrangement for monitoring hive and bees conditions, analyzing obtained data and reporting results to a user; and (e) an arrangement for feeding bees, pest and climate control. (f) An AI based decision making algorithm based on data gathered from the hives which will alert the user suggest and perform beekeeping practices within the unit in an automatic manner.

It is a core purpose of the invention to provide said beehive further comprises thermal *Varroa* mite diagnostic means.

Another object of the invention is to disclose the thermal *Varroa* mite diagnostic means selected from the group a thermal vision camera, a scanner, a visual light camera accompanied with a light source and any combination thereof configured for comb monitoring.

A further object of the invention is to disclose the thermal *Varroa* mite diagnostic means comprises a plurality of heat sensors embedded into said comb.

A further object of the invention is to disclose monitoring and diagnostic means comprising a plurality of optical sensors embedded into said comb.

It is hence one object of the invention to disclose an automatic beehive for commercial beekeeping including honey production and pollination services. The aforesaid automatic beehive comprises: (a) a plurality of honeycomb brood frames and other frames in the hive releasably mounted within at least one hive chamber; (b) a mechanism for removing all kind of bee frames such as honeycomb or brood frames and other types of frames from said hive chamber and inserting said bee frames thereinto; (c) an automated honey harvesting arrangement; (d) an arrangement for monitoring hive and bees conditions, analyzing obtained data and reporting results to a user; and (e) an arrangement for feeding bees, pest and climate control. (f) An AI based decision making algorithm based on data gathered from the hives which will alert the user suggest and perform beekeeping practices within the unit in an automatic manner.

5

It is a core purpose of the invention to provide said arrangement for monitoring bees conditions, analyzing obtained data and reporting results further comprises chemical *Varroa* mite diagnostic means.

Another object of the invention is to disclose the chemical *Varroa* mite diagnostic means comprises at least one chemical sensor mounted in proximity of said bee frames; said at least one chemical sensor is configured for diagnosing *Varroa* mite infection.

A further object of the invention is to disclose the chemical *Varroa* mite diagnostic means comprises a plurality of chemical sensors embedded into said comb.

BRIEF DESCRIPTION OF THE DRAWINGS

Some embodiments of the disclosed subject matter described, by way of example only, with reference to the accompanying drawings. With specific reference now to the drawings in detail, it is stressed that the particulars shown are by way of example and for purposes of illustrative discussion of the preferred embodiments of the present disclosed subject matter only, and are presented in the cause of providing what is believed to be the most useful and readily understood description of the principles and conceptual aspects of the disclosed subject matter. In this regard, no attempt is made to show structural details of the disclosed subject matter in more detail than is necessary for a fundamental understanding of the disclosed subject matter, the description taken with the drawings making apparent to those skilled in the art how the several forms of the disclosed subject matter may be embodied in practice the art how the several forms of the disclosed subject matter may be embodied in practice.

In the drawings:

FIGS. 1a-1d illustrate an automatic unit of several beehives in several views and positions, in accordance with some exemplary embodiments of the disclosed subject matter;

FIG. 2 illustrates several types of frames to be used in the unit shown in FIG. 1a;

FIG. 3 illustrates an interior view of an automatic beehive in accordance with an exemplary embodiment of the disclosed subject matter;

FIG. 4 illustrates comb frame monitoring system in accordance with an exemplary embodiment of the disclosed subject matter;

FIG. 5 illustrates comb frame monitoring system in accordance with an exemplary embodiment of the disclosed subject matter;

FIG. 6 illustrates yet another comb frame monitoring system in accordance with an exemplary embodiment of the disclosed subject matter;

FIG. 7 illustrates additional comb frame monitoring system in accordance with an exemplary embodiment of the disclosed subject matter;

FIG. 8 illustrates yet additional comb frame monitoring system in accordance with an exemplary embodiment of the disclosed subject matter;

FIG. 9 illustrates comb frame illumination system in accordance with an exemplary embodiment of the disclosed subject matter;

FIG. 10a depicts an image of a honeycomb which is a mass of hexagonal prismatic wax cells built by honey bees in their nests to contain their larvae and stores of honey and pollen, on a comb frame onto which image processing was performed in accordance with an exemplary embodiment of the disclosed subject matter;

6

FIG. 10b depicts another image of a honeycomb on a comb frame onto which image processing was performed in accordance with an exemplary embodiment of the disclosed subject matter;

FIG. 11 illustrates a portion of a honeycomb provided with a disinfecting system in accordance with an exemplary embodiment of the disclosed subject matter;

FIG. 12 illustrates an upper view of a monitoring and disinfecting chamber adjacent a beehive chamber in accordance with an exemplary embodiment of the disclosed subject matter;

FIG. 13 illustrates an upper view of a disinfecting system in accordance with an exemplary embodiment of the disclosed subject matter;

FIG. 14 illustrates an upper view of another disinfecting system in accordance with an exemplary embodiment of the disclosed subject matter;

FIG. 15 is an isometric view of a unit of several beehives enclosure with a frame loader;

FIG. 16 is an isometric enlarged view of a frame loader;

FIGS. 17a and 17b are external views of a unit of several beehives; and

FIGS. 18a and 18b are internal views of a unit of several beehives;

FIGS. 19a to 19c are isometric, side and front views of a first embodiment of an arrangement for releasably securing bee frames;

FIGS. 20a to 20c are isometric, side and front views of a second embodiment of an arrangement for releasably securing bee frames;

FIGS. 21a to 21c are side, isometric and enlarged top views of a bee-barrier member provided with mechanical brushes;

FIGS. 22a to 22c are side, isometric and enlarged views of a bee-barrier member provided with air passages;

FIG. 23a is an isometric schematic view of an optical arrangement for monitoring a comb;

FIG. 23b is a schematic view of an optical scanner movable along embedded in a comb;

FIG. 23c is a schematic view of an arrangement of optical sensors embedded in a comb;

FIG. 23d is a schematic view of a mirror which directs an image of the comb to a camera;

FIG. 24a is an isometric schematic view of a sensor mounted in front of a comb for diagnosing *Varroa* mite; and

FIG. 24b is a schematic view of an arrangement of chemical sensors embedded into a comb for diagnosing *Varroa* mite.

DETAILED DESCRIPTION OF THE INVENTION

Before explaining at least one embodiment of the disclosed subject matter in detail, it is to be understood that the disclosed subject matter is not limited in its application to the details of construction and the arrangement of the components set forth in the following description or illustrated in the drawings. The disclosed subject matter is capable of other embodiments or of being practiced or carried out in various ways. Also, it is to be understood that the phraseology and terminology employed herein is for the purpose of description and should not be regarded as limiting. The drawings are generally not to scale. For clarity, non-essential elements were omitted from some of the drawings.

A side-sliding configuration of hive chambers and frames (opposite to the standard top opening hives) allow for

vertical stacking of hives and maximizing the amount of colonies served by the unit. The side-sliding extraction and insertion of frames, show-cased in the Beewise prototype for monitoring, is to be further developed to allow for frames relocation, limited compatibility to standard (Langstroth) hives and other types, and include feeder, queen excluder and partition frames. This development will support the automation of vast majority of beekeeping actions and practices. It will also allow for easy migration of colonies between traditional and Beehome platforms. The design objective is a box-frames system that includes all the different functioning frames in a unified automation-friendly form-factor, based of standard (Langstroth) frame size for limited compatibility. In order to achieve this, additional materials are to be examined for use that is not use in hive chambers traditionally (such as silicones, soft plastics and polymeric foams (existing hive chambers and frames implementation wood, rigid plastics and metals).

An XYZ Cartesian robot is at the base of the system used to manipulate the different frames in the hive chamber. An additional 180 degrees rotary axis for two sided hive-array service and two sided visual monitoring is introduced. A combination of electric linear modules (belt and ball-screw driven) and pneumatic linear cylinders and grippers are used to achieve the best results considering the required precision, speed, force, durability, energetic efficiency, and cost.

Custom designed end unit ('frame loader') to deliver considerable tolerance in positioning (to overcome the biological variability in the hives) and control the bees allocation while manipulating frames in the hives. All while keeping clear sight for visual monitoring and keeping honey and wax away from mechanical parts.

The data relating to the colonies is collected using a variety of off-the-shelf sensors. The key one being a camera or scanner module chosen with suitable optics and lighting to produce the best images as raw data for image processing. The optical sensor is supplemented with load cell and in-hive environmental sensors (temperature, sound, and humidity). RFID tagging of the frames is considered for more efficient data management in the system and improved storage and logistics management for the user. Environmental sensors are also implemented to track the conditions in the unit and outside to drive the climate control system and ensure proper conditions in the unit. The units systems (robot, feeding, solar-power etc.) are self-monitored using the relevant standard industrial sensors (such as inductive switches, liquid level switch, load cells, etc.)

The product contains off-the-shelf industrial level CPU and I/O controllers to perform the on-board computation, actions control and data acquisition.

Reference is now to FIGS. 1a-1d illustrating an automatic unit of several beehives in several views and positions, in accordance with some exemplary embodiments of the disclosed subject matter. Automatic beehive 100 is an enclosure 102 provided with brood, super, and other chambers sized to fit the needs of the colony, as will be elaborated herein after. Beehive 100 has several openings for different purposes. At the front side, a main opening with a door 104 is provided so that a beekeeper or technician can reach the interior of the enclosure 102, while optionally, additional two service openings can be provided with doors 106 on the sides of the enclosure, in order to collect honey, honeycombs, old/damaged frames, add new frames etc. Bee passage holes 108 are provided preferably to the sides of the enclosure, were the bees are intended to be accommodated. The holes 108 can be provided in different shapes, orientations, and sizes, without limiting the scope of the subject matter.

FIG. 1b is a top view of the automatic unit of several beehives 100 while the roof of the enclosure is removed in order to be able to observe the interior order of the different chambers of the enclosure 102. The enclosure sides comprise horizontal rows of slots that can receive plurality of frames 112 depicted in FIG. 2. Alternatively, and optionally, several floors of frames can be organized one on top of the other as can be seen in FIG. 1c. Each of the plurality of frames 112 can be removed from its slot and returned to it.

The frames are separated from one another allowing a gap of air between them so as to allow space for the bees to be accommodated and build the honeycombs on the frames, usually about 4-9 mm between the frames should suffice for the bees.

Additionally, and preferably, the unit is provided with an air control system (not shown in the figures) that monitors characteristics or the beehive interior environment such as but not limited to temperature, humidity, allergens etc.

Additionally, and preferably, containers of sugar and water are provided on top of the beehive or in any other place suitable for it. Additionally, and preferably, the beehive is provided with wheels so it can be easily transported from one site to the other.

Reference is now made to FIG. 2 illustrating several types of frames to be used in the unit of several beehives shown in FIG. 1a. Most of the frames in the beehive are comb frames such as frame 202. Frame 202 is similar to a standard comb frame and is design to allow the bees to brood and build the honeycomb. It should be mentioned that each honeycomb comprises a plurality of hexagonal prismatic wax cells that are built by the community of honeybees in which their larvae and stores of honey and pollen are placed. The differentiation between the cells is crucial in the honey harvesting process, and monitoring the comb frames is needed in order to get as much information as needed.

Returning to FIGS. 1b and 1c, one can observe other chambers in the enclosure 102. Between the two rows of bee chambers 110, a monitoring and operating chamber 114 is provided in which at least one comb frame can be monitored so as to collect information. In order to monitor a frame of the plurality of frames, the frame to be examined 116 is removed from its place to the monitoring chamber 114 for inspection. The inspection can be performed by a variety of methods such as scanning, photographing, or any other method by which the surface of the honeycomb on the frame 116 is being imaged, after which image processing can optionally be employed in order to infer and differentiate the contents of the vast number of cells. In FIG. 1c, one can see more than a single frame to be examined in extracted from its positioning into the monitoring chamber 114.

Since the frames can be automatically removed from their slots to be examined and treated, they can be harvested in case the image processing system results indicate that the frame is ready for harvesting. Honey can be collected from frames that are ready for harvesting.

Reference is now made to FIG. 3 illustrating a cut through a portion of the automatic beehive in accordance with some exemplary embodiments of the disclosed subject matter. A hive chamber 300 is situated adjacent to a monitoring chamber 302. The hive chamber 300 comprises a plurality of frames 304 that are vertically placed one near the other in a row, as shown herein before. Opposite the frames, in the monitoring chamber 302, a set of rails 306 is provided. The set of rails 306 is organized to form slots, wherein each of the slots is capable of receiving an oppositely positioned frame. It is illustrated in the figure that one comb frame 308 is extracted from the hive chamber 300 into the monitoring

chamber **302** through a corresponding slot. The frame can be extracted and retracted back to its position using a displacement system.

In this embodiment, in FIG. 3, the displacement system is positioned in an actuating chamber **310** that is adjacent to the hive chamber **300** and comprises one or more motors **312** and pushing rods **314**. Other displacement systems can be used without limiting the scope of the disclosed subject matter. Optionally, a controller **316** that is electrically connected and controls the engines and the rods movements is provided so as to ensure proper functioning of the system is provided. The controller **316** can be placed within the actuating chamber **310** or in any other part of the beehive as well as externally placed. It is also possible to use wireless connection between the controller and the displacement system.

The frame **308** in the monitoring chamber **302** is being monitored preferably using a camera **318** that is preferably attached to the side of the monitoring chamber **302** and is directed to image an oppositely positioned frame. The camera **318** can be any optical sensor that converts light into electrical signal such as photoconductive devices. In case light is necessary for the imaging process, illumination is provided. At least one illuminator **320** is provided adjacent to the camera **318**. The illuminator can be LED, laser, or any other type of lighting. Information regarding the data processing will be explained hereinafter.

The frames **308** are extracted from the hive chamber **300**, where the community of bees is working. In order to prevent withdrawal of the bees from the hive chamber while the comb frame is extracted, the exit area is provided with barriers **322** that can be a full surface or has brush like structure from both sides of the frame that prevents the bees from exiting the hive chamber. Returning to FIG. 2, additional types of frames are provided. Queen excluder **204** is built according to the characteristics of the system; however, it accords the queen excluders that are provided in the art. In the same manner, a feeding frame **206** and a separator **208** are provided to separate between different sub-chambers of the bee chamber **110**. Placement and displacement of separator **208** and queen excluder **204** allow varying the number of frames allocated for each colony in the unit, as well as varying the size of the brood and honey chambers of each individual colony.

All types of frames are removable and can be extracted and retracted from their positioning from different reasons such as changes in the beehive structure and size, treatment of a unique frame, monitoring the comb frames, or any other maintenance action.

Monitoring the comb frames can be performed using several other embodiments as follows:

Reference is now made to FIG. 4 illustrating comb frame monitoring system in accordance with some exemplary embodiments of the disclosed subject matter. An upper view of a portion of a hive chamber **400** is provided with several comb frames **402**. A scanning or imaging device, an imager **404** is provided between the frames **402** so it can image the surface of the frame. In order to allow the imager **404** to be positioned between the frames **402**, the two frames from both sides of the device should be moved apart so as to increase the gap **406** that normally exists between the frames. Preferably, two actuators are provided. A first actuator **408** is provided so as to move the frames so as to allow the imager to have a sufficient gap between them and a second actuator **410** is provided so as to move the imager

404 from one gap to the other. Both actuators **408** and **410** can be positioned in any area of the chamber **400** or the beehive.

Reference is now made to FIG. 5 illustrating another comb frame monitoring system in accordance with some exemplary embodiments of the disclosed subject matter. An upper view **5** of a portion of a hive chamber **500** is provided with several comb frames **502**. A plurality of scanning or imaging device, each imager **504** is provided between two adjacent frames **402** so it can image the surface of the two frames that faces each other.

Reference is now made to FIG. 6 illustrating yet another comb frame monitoring system in accordance with some exemplary embodiments of the disclosed subject matter. A side view (right hand side) and frontal view (left hand side) of a cylindrical hive chamber **600** is illustrated. Hive chamber **600** is built as a cylinder so that rounded comb frames **602** are arranged one beside the other. A plurality of imagers **604** is provided between each pair of adjacent frames while the imagers are rotating about an axis **606**. In the frontal view, one can see that the imager **604** is a line imager that rotates according with the arrow and scans the full area of the frame **604**.

Reference is now made to FIG. 7 illustrating additional comb frame monitoring system in accordance with some exemplary embodiments of the disclosed subject matter. An upper view of a single frame is shown in the figure. The comb frame **700** comprises a middle compartment **702** while on both opposite surfaces of the comb frame **700**, cells of honeycomb **704** are built by the bees. Imager **706** is provided within the inner compartment **702** so that it can provide images of the honeycomb cells **704**.

Reference is now made to FIG. 8 illustrating yet additional comb frame monitoring system in accordance with some exemplary embodiments of the disclosed subject matter. A frontal view of a portion of a comb frame **800** is shown to have honeycomb cells **802** on its surface. Each cell **802** is provided with a miniature sensor **804** that images the interior of the cell and provides information on the cell content.

Reference is now made to FIG. 9 illustrating comb frame illumination system in accordance with some exemplary embodiments of the disclosed subject matter. An upper view of a single frame is shown in the figure. The comb frame **900** comprises a middle compartment **902** while on both opposite surfaces of the comb frame **900**, cells of honeycomb **904** are built by the bees. Illuminator **906** is provided within the inner compartment **902** so that it can provide improved image quality when an imager images the honeycomb. It should be mentioned that this type of inner illumination that is not producing heat within the frame can be used for any one of the previous illustrated imager embodiments. As mentioned herein before, in order to allow automatic beehives to function, data and information should be collected from the beehive so as to be able to provide treatment to the bees and the honey produced in the beehive. As indicated, monitoring the frames and the honeycomb cells is performed in or out of the hive chamber. Data is collected per cell as to the content of each cell, while bearing in mind that there are thousands of cells in a beehive. Each cell can be as followed: empty, contains bee stages in the phase of an egg, larvae, a sealed larvae, queen larvae and drone larvae or contains pollen, honey, or sealed honey. Integrating information regarding the cells contents, one can infer regarding the fertility of the queen, swarming, diseases, existence of

11

parasites, a combination thereof and the like. Imaging of the surface of the honeycomb can provide vast amount of information.

Reference is now made to FIG. 10a depicting an image of a honeycomb on a comb frame onto which image processing was performed in accordance with some exemplary embodiments of the disclosed subject matter. The image comprises the differentiation between different types of cells in the honeycomb as well as showing where the bees are situated. As examples, sealed larvae cells are shown in pink circles, sealed honey cells that are ready to be harvested are shown in green circles, and bees are shown in blue squares. Image processing can also identify pests in the cells or on the honeycomb surface such as the *Varroa destructor* mite.

Reference is being made to FIG. 10b depicting another image of a honeycomb on a comb frame onto which image processing was performed in accordance with some exemplary embodiments of the disclosed subject matter. In this image, only bees are detected and taken into account as data. Upon receiving the data from the imaging and processing systems, appropriate actions should be taken, if necessary, such as but not limited to disinfecting the honeycomb, removing frames, removing bees, imaging a specific frame as non-schedule action, harvesting honey, moving frames from one colony to the other, moving the queen excluder and the brier frame, feeding sugar syrup, heating or cooling the unit, applying pesticides, removing unwanted queen larvae cell, adding a queen, replacing a queen etc. The monitoring chamber can act also as a disinfecting and/or treatment chambers. It should be mentioned that the chambers can be separated or combined in any combination.

Reference is now made to FIG. 11 illustrating a portion of a honeycomb provided with a disinfecting system in accordance with some exemplary embodiments of the disclosed subject matter. Each cell 1102 of the honeycomb 1100 is provided with a miniature heater 1104 while the heaters of all cells are electrically connected to a common controller (not shown in the figure) that is configured to control the heating of a specific or several cells if detected to be infected with a parasite that can be destroyed by applying sufficient heat. Reference is now made to FIG. 12 illustrating an upper view of a monitoring and disinfecting chamber adjacent a hive chamber in accordance with some exemplary embodiments of the disclosed subject matter. A monitoring and disinfecting chamber 1200 is adjacent to a hive chamber 1202 of an automatic beehive. Actuating system 1204 is adjacent to the hive chamber 1202, wherein the actuating system is configured to push a single comb frame 1206 of the plurality of frames 1208 that are aligned in the hive chamber 1202 into the monitoring and disinfecting chamber 1200 at a time. The actuating system 1204 is configured to push the frame into the monitoring and infecting chamber in order to be examined or in order to be treated. As mentioned herein before, a monitoring chamber is preferably provided with at least one camera 1210 directed towards the extracted frame 1206 and illuminators 1212, also directed towards the extracted frame 1206. Since honeycombs are built on two surfaces of the frame, the camera and illuminators are provided on both sides of the chamber. The monitoring and disinfecting chamber 1200 is provided also with disinfecting means that are operated immediately after a detection of a parasite or other problem in a specific cell, or can be operated after all frames are imaged.

FIG. 12 illustrates two types of disinfecting systems, operating on both sides of the frame 1206. Any combination of the systems or other such systems is possible without limiting the scope of the disclosed subject matter. Disinfecting

12

tor system 1214 is provided with a supporting board 1216 that is configured to move along the sides of the monitoring and disinfecting chamber 1200 so as to get distant and closer to the extracted frame 1206 and a disinfecting head 1218 that is provided with a pointing edge that can physically puncture the cell, in case it is sealed, and treat the cell through the pointing edge using optical or chemical means, a combination thereof and the like in order to treat a specific cell. On the other side of the extracted frame 1206, another disinfecting system 1220 is provided. A disinfecting head 1224 is mounted on an arm 1222, that can be a robotic arm, that directs the disinfecting head 1224 to a specific location opposite a specific cell that needs treatment. The disinfecting head is provided, similarly to the disinfecting head 1218, with a pointing edge that can treat by physical or chemical methods, a combination thereof or the like, the honeycomb in the level of a single cell.

Reference is now made to FIG. 13 illustrating an upper view of a disinfecting system in accordance with some exemplary embodiments of the disclosed subject matter. Disinfecting system 1300 is configured to be positioned between two adjacent frames 1302. A disinfecting head 1304 is moving along a string 1306 from left to right and vice versa in order to be positioned in the correct positioning for disinfecting a specific cell while the string can move up and down so the whole surface of the frame is covered and can be reached by the disinfecting head. The disinfecting head 1304 is provided with two pointing edges on both sides so as to reach each one of the facing one another honeycomb cells.

In this embodiment, the disinfecting system can be incorporated within an imager that is provided as well between the frames and was shown herein in FIG. 5 or 6, as examples.

Reference is now made to FIG. 14 illustrating an upper view of another disinfecting system in accordance with some exemplary embodiments of the disclosed subject matter. A disinfecting system 1400 is positioned in a single spot in a disinfecting chamber opposite a bee frame 1402. As already noted, the comb frame is provided with built up of honeycomb on the surface of the frame, on both sides. When a specific cell 1404 is detected to be infected, it has to be treated. Disinfecting system 1400 is provided with a rotating head 1406 that can direct a coherent ray such as laser 1408 to the specific cell 1404 that needs treatment and heat it in order to disinfect the cell. This disinfecting system can be employed in any adequate scanning or imaging systems and can also be mobile and positioned in any positioning in the monitoring and disinfecting chamber.

Reference is now made to FIG. 15 presenting an internal isometric view of unit of one or several beehives enclosure 102. Frame loader 140 is displaceable along main axis 142 which is parallel to a face (not shown) of hive chambers 110. Numeral 136 refers to a vent creating an air flow into/out of the beehive. Camera 138 captures images of bee frames and transmits obtained images to control unit which is configured for analyzing them in terms of bees conditions, honey harvesting and pest control. The results of the carried out analysis are reported to a user. Camera 138 is provided with a light source for illumination of the bee frames during capturing their images.

Numeral 150 refers to an opening for the bees exiting or entering the hives, 105. The opening is divided into segments which can be either open or closed. Each segment of the opening has a bar running underneath the hive chamber which can be pushed or pulled by the cartesian robot, thus controlling whether the segment is open for the passage of

bees or closed. Thus, the location and number of open and closed segments is controlled from within the unit by the cartesian robot or another mechanism.

Reference is now made to FIG. 16 presenting an enlarged isometric view of the frame loader. A bee frame (not shown) is placeable into frame holder 140 which is displaceable along main axis rails 158 by stepper motor 164 by means of drag chain and linear drive belt 160 and 162, respectively. Frame loader 140 is connected to rails 158 via rotating table 146. The bee frame is movable along loader rails 152 via loader gate 154 and securable by gripper 156. Linear displacement along rails 152 is carried out by ball screw linear actuators 150.

Reference is now made to FIGS. 17a and 17b presenting external views of the beehive. Specifically, a level of the beehive is adjustable by means support members 178. A honey tank access and a service door are indicated by numerals 170 and 172 respectively. Service door 172 is provided with vent slits 174. Sugar loading is performed via port 176. Solar panel array is used as an alternative source of energy together with electric batteries 186. Water and pesticides are loaded via port 182. Numeral 180 refers to a service ladder. Opening and porches 194 are designed for landing bees and entering and exiting the hive.

The opening is divided into segments, which can be either open or closed. Each segment of the opening has a bar running underneath the hive chamber which can be pushed or pulled by the cartesian robot, thus controlling whether the segment is open for the passage of bees or closed. Thus, the location and number of open and closed segments is controlled from within the unit by the Cartesian robot or another mechanism.

Tools cabin and interface chamber are indicated by numerals 190 and 192, respectively.

Reference is now made to FIGS. 18a and 18b presenting internal views of the beehive. Bee frames are stored in store 212. Honey harvested by centrifugal machine 210 is stored in honey tank 226. Frame loader 140 is two-axis displaceable by Cartesian XY robot 224. Tanks 230, 232 and 234 accommodate water, sugar and pesticides, respectively. The aforesaid materials are mixed in mixer 236.

Reference is now made to FIGS. 19(a-c) and 20(a-c) presenting isometric, side and front views of first and second embodiments of a hanging arrangement configured for releasable securement of bee frame 308 to base plate 1500/1600. In the first embodiment shown in FIGS. 19(a-c) bee frames 308 is provided with t-slot while base plate 1500 has t-head connecting elements which are releasably securable within the aforesaid t-slot.

According to the second embodiment of the hanging arrangement, a plurality of t-slots are machined within base plate 1600 and t-head connecting elements 1610 carried by-head connecting elements are releasably securable within t-slot 1620.

According to the present invention, the arrangement for removing and inserting the bee frames includes bee-barrier members configured for individually embracing said bee frames such that each bee frame passes through said member. While replacement of the bee frames is performed, bees maintained within said beehive are prevented from escaping from said beehive during replacement of said frames. Each of said bee-barrier member is provided with means for removing bees from said bee frames during removing thereof from said beehive.

Reference is now made to FIGS. 21a to 21b presenting side, isometric and enlarged top views of a bee-barrier member provided with mechanical brushes.

Specifically, bee-barrier member 1700 is provided with brushes 1710. Bee frame 308 is pulled via member 1700 such that bees 1730 are removed from bee frame. Numeral 1720 refers to a beehive wall. A blade, a comb and a scrubber are also in the scope of the present invention.

Reference is now made to FIGS. 22a to 22c presenting side, isometric and enlarged views of a bee-barrier member provided with air passages. Bee-barrier member 1800 is provided with air passages 1810 fluidly connectable to a source of compressed air configured for blowing off bees from said bee frames during removing the aforesaid frame.

In order to treat colonies which are infected with *Varroa* one can treat the specific cells in which the *Varroa* mite reproduces. Identification of infected cells can be achieved by means of detection of heat traces of such cells. Differences in temperature between infected and uninfected cells can be used to distinguish infected cell which contain the *Varroa* mite. Such cells can then be treated. Treatments may include mechanical punctuation of the cell, chemical treatment, heat treatment, optical treatment, radiation or any other treatment applied to the infected cells which kills, harms or sterilizes the *Varroa* mite, either directly or indirectly through its bee brood host. In one such embodiment, infected cells may be moved by the BeeHome robotic mechanism to a treatment area or unique treatment operates. Detection of heat emitted by the cells of the colony can be done via a digital optical device (heat-based camera) or by other heat sensors installed in either the interior or exterior of the comb and/or the hive.

Exemplary embodiments of heat-based detection of cells infected by *Varroa* may include but are not limited to:

1. A digital optical device which captures an image or video recording of the frame. Image or video is then analyzed to detect cells with unique temperature profile which might indicate the presence of *Varroa* mites.
2. Sensors which are installed in the cell of the frame and enable sensing the temperature of the cell. The data collected by these sensors is then analyzed to detect cells with unique temperature profile which might indicate the presence of *Varroa* mites.

Reference is now made to FIG. 23a presenting a first exemplary optical embodiment of an arrangement for ongoing monitoring of the overall state and health of the honeycombs and bee frames and diagnosing the cells infected by *Varroa*. Camera 1900 is disposed in front of comb 1910. A part of cells 1920 is infected (marked by numeral 1930).

Reference is now made to FIG. 23b presenting a second exemplary optical embodiment of the diagnosing arrangement. Optical scanner 1905 is movable over comb 1910 or comb 1910 is movable over optical scanner 1905 in order to monitor the overall state and health of the honeycombs and bee frames and.

Reference is now made to FIG. 23c presenting a third exemplary optical embodiment of the diagnosing arrangement. An arrangement of heat sensors 1940 is embedded into comb 1910.

Reference is now made to FIG. 23d presenting a fourth exemplary embodiment of the optical arrangement usable for monitoring conditions of the bees, bee cells and frames accommodated in the beehive including diagnosing bee diseases. Camera 1900 is able to capture an image of different locations on the surface of comb 1910 reflected by mirror 1970

In order to treat colonies, which are infected with *Varroa*, one can treat the specific cells in which the *Varroa* mite reproduces. Identification of infected cells can be achieved

15

by means of detection of chemical traces in such cells. Unique Chemical traces can be used to distinguish infected cell, which contain the *Varroa* mite. Such cells can then be treated. Treatments may include mechanical punctuation of the cell, chemical treatment, heat treatment, optical treatment, radiation or any other treatment applied to the infected cells which kills, harms or sterilizes the *Varroa* mite, either directly or indirectly through its bee brood host. In one such embodiment, infected cells may be moved by the BeeHome robotic mechanism to a treatment area or unique treatment apparatus. Detection of chemical traces in the cells or chemical traces emitted by the cells of the colony can be done via a chemical sensors installed either in the exterior or the interior of the comb and/or the hive.

Exemplary embodiments of chemical based detection of cells infected by *Varroa* include but are not limited to:

1. A device, which senses chemical traces outside the cells. Data produced by the device is then analyzed to detect cells with unique chemical profile, which might indicate the presence of *Varroa* mites.
2. Sensors, which are installed in the cell of the frame and enable sensing chemical traces in the cell. The data collected by these sensors is then analyzed to detect cells with unique chemical profile which might indicate the presence of *Varroa* mites.

Reference is now made to FIG. **24a** presenting a first exemplary embodiment of an arrangement for diagnosing the cells infected by *Varroa*. Chemical sensor **1950** is disposed in front of comb **1910**. A part of cells **1920** is infected (marked by numeral **1930**).

Reference is now made to FIG. **24b** presenting a second exemplary embodiment of the diagnosing arrangement. An arrangement of chemical sensors **1960** is embedded into comb **1910**.

It should be noticed that in all the embodiments shown herein as well as other possible embodiments, a control unit, which is seen in several of the embodiments, should be electrically connected to the systems such as the disinfecting system, monitoring system, actuation system, a combination thereof and the like. The control unit will coordinate the full functioning of the beehive to allow it to work in automatic manner.

16

The unit of several beehives in accordance with the disclosed subject matter can be a portable unit that can be transported from one place to another for purposes such as relocation and crop pollination. Another feature is a solar panel that can provide electricity to the systems of the beehive.

Although the invention has been described in conjunction with specific embodiments thereof, it is evident that many alternatives, modifications and variations will be apparent to those skilled in the art. Accordingly, it is intended to embrace all such alternatives, modifications and variations that fall within the spirit and broad scope of the appended claims. All publications, patents and patent applications mentioned in this specification are herein incorporated in their entirety by reference into the specification, to the same extent as if each individual publication, patent, or patent application was specifically and individually indicated to be incorporated herein by reference. In addition, citation, or identification of any reference in this application shall not be construed as an admission that such reference is available as prior art to the present invention.

The invention claimed is:

1. A system including:

- a plurality of bee frames releasably mounted within at least one hive chamber;
- a mechanism configured to extract a bee frame from a hive chamber and inserts a bee frame into a hive chamber;
- an imaging system configured to acquire an image of a frame; and
- a processing unit configured to process the image and determine, for each of a plurality of cells in a frame, the cell is one of: empty, contains an egg, contains a larva, is a sealed larva cell, contains a queen larva, contains a drone larva, contains pollen, contains honey, or is a sealed honey cell.

2. The system of claim **1**, including a pointing edge adapted to physically puncture a specific cell containing a queen larva.

* * * * *