



US011896692B2

(12) **United States Patent**  
**Akinbobola et al.**

(10) **Patent No.:** **US 11,896,692 B2**  
(45) **Date of Patent:** **\*Feb. 13, 2024**

(54) **BEAUTY CARE PRODUCT**

(71) Applicant: **WELLA OPERATIONS US, LLC**,  
Calabasas, CA (US)

(72) Inventors: **Victor Akinbobola**, West Chester, OH  
(US); **Alton Lloyd Finley, III**,  
Cincinnati, OH (US); **Matthew David**  
**Joseph**, Pittsford, NY (US);  
**Christopher Robert Kopulos**,  
Cincinnati, OH (US); **Nicholas Arthur**  
**Ruebusch**, Fort Thomas, KY (US)

(73) Assignee: **WELLA OPERATIONS US, LLC**,  
Calabasas, CA (US)

(\* ) Notice: Subject to any disclaimer, the term of this  
patent is extended or adjusted under 35  
U.S.C. 154(b) by 0 days.  
  
This patent is subject to a terminal dis-  
claimer.

(21) Appl. No.: **18/079,694**

(22) Filed: **Dec. 12, 2022**

(65) **Prior Publication Data**

US 2023/0113258 A1 Apr. 13, 2023

**Related U.S. Application Data**

(60) Continuation of application No. 16/850,850, filed on  
Apr. 16, 2020, now abandoned, which is a  
(Continued)

(30) **Foreign Application Priority Data**

Oct. 31, 2013 (EP) ..... 13191005

(51) **Int. Cl.**  
**B65D 79/00** (2006.01)  
**A61K 8/22** (2006.01)  
(Continued)

(52) **U.S. Cl.**  
CPC ..... **A61K 8/22** (2013.01); **A45D 7/04**  
(2013.01); **A45D 19/0066** (2021.01);  
(Continued)

(58) **Field of Classification Search**  
CPC ..... **A45D 7/04**; **A45D 2019/025**; **A45D**  
**2007/001**; **A45D 2019/0066**;  
(Continued)

(56) **References Cited**

**U.S. PATENT DOCUMENTS**

4,946,053 A 8/1990 Conrad  
6,077,579 A 6/2000 de Laforcade  
(Continued)

**FOREIGN PATENT DOCUMENTS**

CN 1585610 A 2/2005  
EP 1593605 A1 11/2005  
(Continued)

**OTHER PUBLICATIONS**

“Chinese Application Serial No. 201480022427.X, Office Action  
dated Apr. 18, 2018”, w/ English translation, 6 pgs.  
(Continued)

*Primary Examiner* — Rachel R Steitz  
*Assistant Examiner* — Brianne E Kalach  
(74) *Attorney, Agent, or Firm* — Dennemeyer &  
Associates LLC; Victoria Friedman

(57) **ABSTRACT**

A beauty care product comprising a sealable plastic con-  
tainer, a sealing means and a beauty care component is  
provided, wherein the container of which is resistant to  
random, uncontrolled deformation under a substantial pres-  
sure differential between the environment and inside the  
container, yet having an affordable cost of manufacture  
and/or being appealing to the consumer. A kit comprising  
said product thereof, a method of manufacturing said prod-  
(Continued)

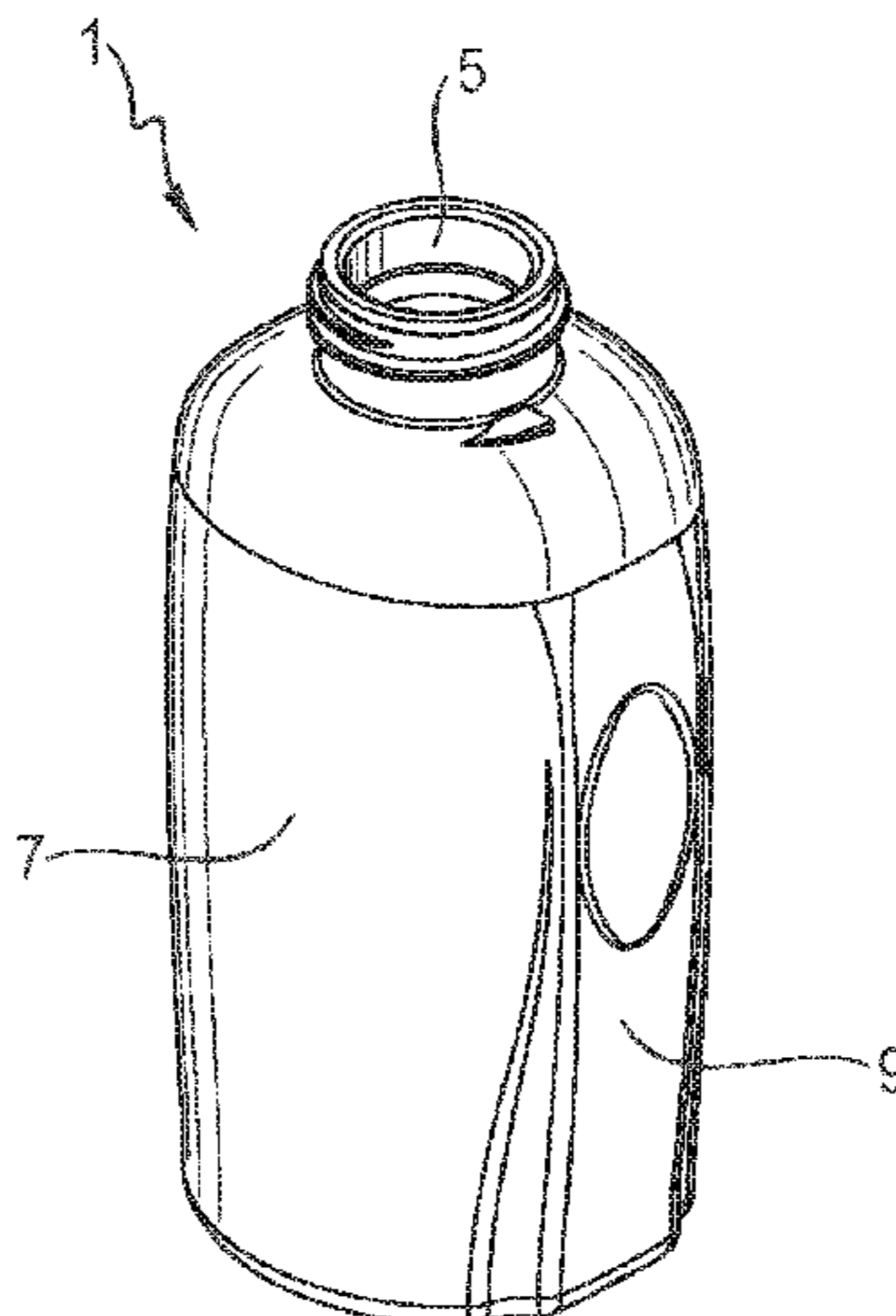

uct, and a method of using said product for application onto skin and/or hair are also provided.

**18 Claims, 2 Drawing Sheets**

**Related U.S. Application Data**

continuation of application No. 16/560,292, filed on Sep. 4, 2019, now abandoned, which is a continuation of application No. 15/042,288, filed on Feb. 12, 2016, now Pat. No. 10,441,515, which is a division of application No. 14/265,722, filed on Apr. 30, 2014, now Pat. No. 9,289,045.

(60) Provisional application No. 61/820,346, filed on May 7, 2013.

(51) **Int. Cl.**

*B65D 1/32* (2006.01)  
*B65D 1/02* (2006.01)  
*A45D 19/00* (2006.01)  
*A45D 7/04* (2006.01)  
*A61K 8/02* (2006.01)  
*A61Q 5/10* (2006.01)  
*A61Q 5/08* (2006.01)

(52) **U.S. Cl.**

CPC ..... *A61K 8/0204* (2013.01); *A61Q 5/08* (2013.01); *A61Q 5/10* (2013.01); *B65D 1/023* (2013.01); *B65D 1/0207* (2013.01); *B65D 1/0223* (2013.01); *B65D 1/32* (2013.01); *B65D 79/0084* (2020.05); *A45D 2200/058* (2013.01); *A45D 2200/25* (2013.01); *A61K 2800/87* (2013.01); *B65D 2501/0081* (2013.01)

(58) **Field of Classification Search**

CPC ..... *A45D 2200/058*; *A45D 2200/25*; *A61K 8/22*; *B65D 79/0084*

See application file for complete search history.

(56)

**References Cited**

U.S. PATENT DOCUMENTS

6,637,613 B2 10/2003 Shimada  
 7,163,123 B2 1/2007 Bezek  
 7,425,220 B2 9/2008 Barrass  
 D653,120 S 1/2012 Dombrowski  
 9,289,045 B2 3/2016 Akinbobola  
 2005/0067369 A1 3/2005 Trude

2006/0054635 A1 3/2006 Iwahashi  
 2008/0257856 A1 10/2008 Melrose  
 2009/0050171 A1 2/2009 Barrass  
 2009/0095702 A1 4/2009 Ungrady  
 2010/0126523 A1 5/2010 Fujinuma  
 2012/0175338 A1 7/2012 Castillo Higareda  
 2013/0292355 A1 11/2013 Lausted  
 2013/0313217 A1 11/2013 Yamamoto

FOREIGN PATENT DOCUMENTS

EP 2087878 A1 8/2009  
 JP 2003276719 A 10/2003  
 JP 2008291020 A 12/2008  
 JP 4357183 B2 11/2009  
 JP 2010179063 A 8/2010  
 JP 2016525987 A 9/2016  
 WO 2004071887 A1 8/2004  
 WO 2005047121 A2 5/2005  
 WO 2014182511 A1 11/2014

OTHER PUBLICATIONS

“Chinese Application Serial No. 201480022427 X, Office Action dated Jan. 15, 2018”, Without English Translation, 6 pgs.  
 “Chinese Application Serial No. 201480022427.X, Office Action dated Mar. 23, 2017”, (w/ English Translation), 13 pgs.  
 “Chinese Application Serial No. 201480022427 X, Response filed Dec. 27, 2017 to Office Action dated Mar. 23, 2017”, (w/English Translation of Claims), 9 pgs.  
 “Chinese Application Serial No. 201480022427.X, Response filed Jun. 20, 2018 to Office Action dated Apr. 18, 2018”, w/ English Claims, 10 pgs.  
 “Chinese Application Serial No. 201480022427.X, Response filed Mar. 28, 2018 to Office Action dated Jan. 15, 2018”, w/ English Claims, 10 pgs.  
 “European Application Serial No. 13191005.1, Extended European Search Report dated Apr. 22, 2014”, 7 pgs.  
 “European Application Serial No. 13191005.1, Response filed Mar. 26, 2015 to Extended European Search Report dated Apr. 22, 2014”, 6 pgs.  
 “International Application Serial No. PCT/US2014/035976, International Preliminary Report on Patentability dated Nov. 19, 2015”, 8 pgs.  
 “International Application Serial No. PCT/US2014/035976, International Search Report dated Jul. 10, 2014”, 3 pgs.  
 “International Application Serial No. PCT/US2014/035976, Written Opinion dated Jul. 10, 2014”, 6 pgs.  
 “Japanese Application Serial No. 2016-512945, Examiners Decision of Final Refusal dated Jul. 11, 2017”. (w/ English Translation), 6 pgs.  
 “Japanese Application Serial No. 2016-512945, Office Action dated Nov. 8, 2016”, (w/ English Translation), 4 pgs.  
 “Japanese Application Serial No. 2016-512945, Written Argument and Amendment filed Apr. 24, 2017 to Office Action dated Nov. 8, 2016”, (w/English Translation), 15 pgs.

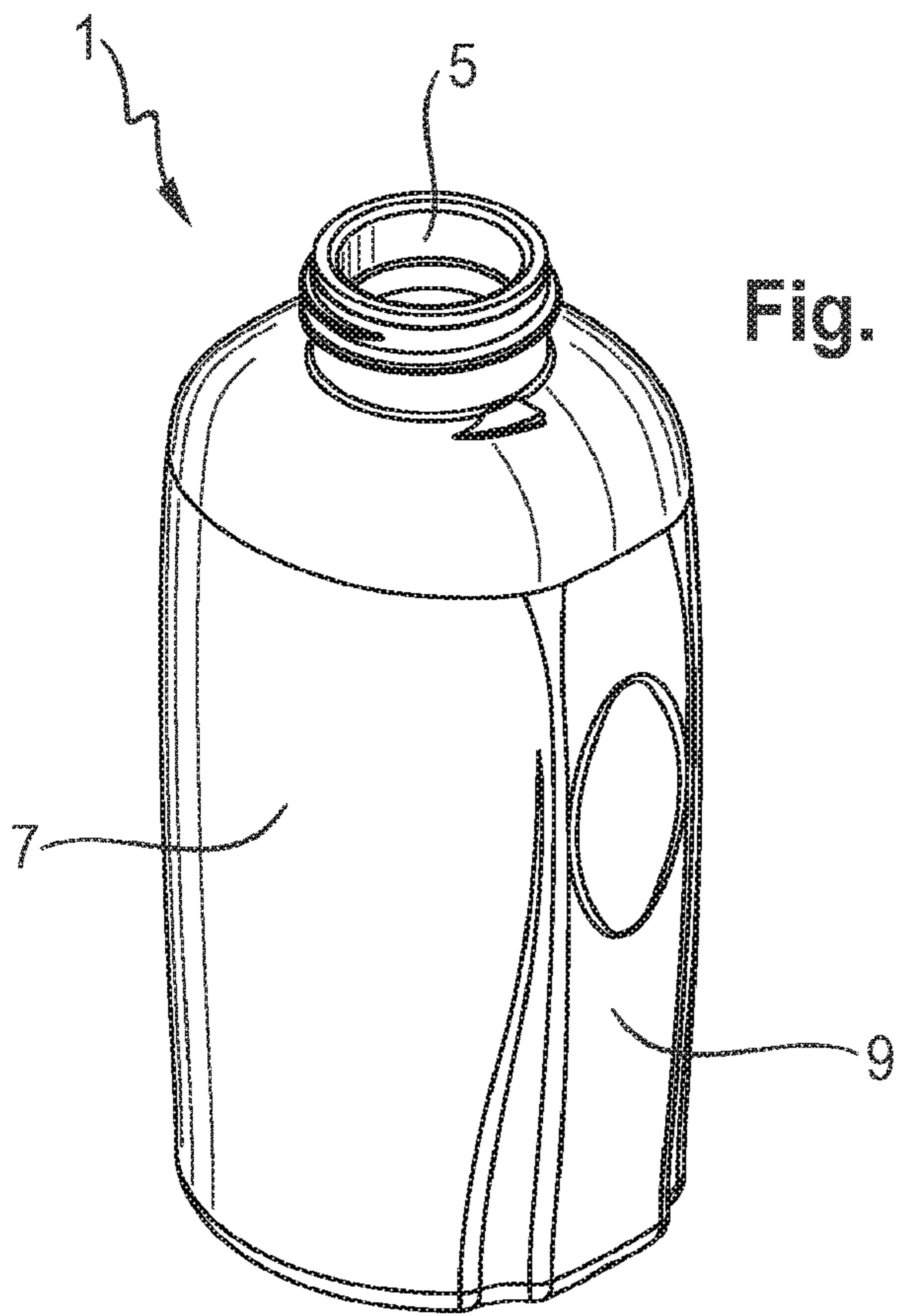

Fig. 1

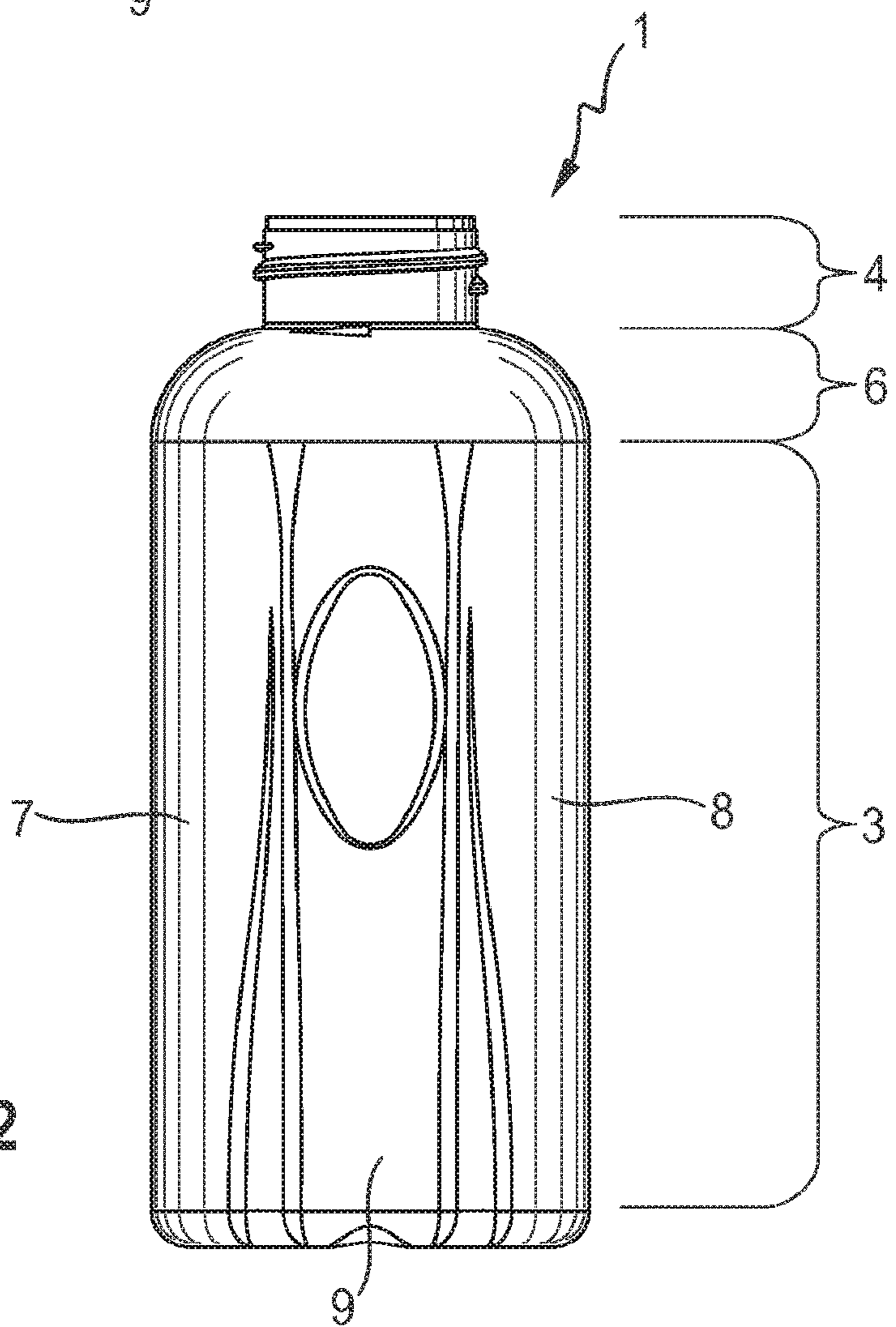

Fig. 2

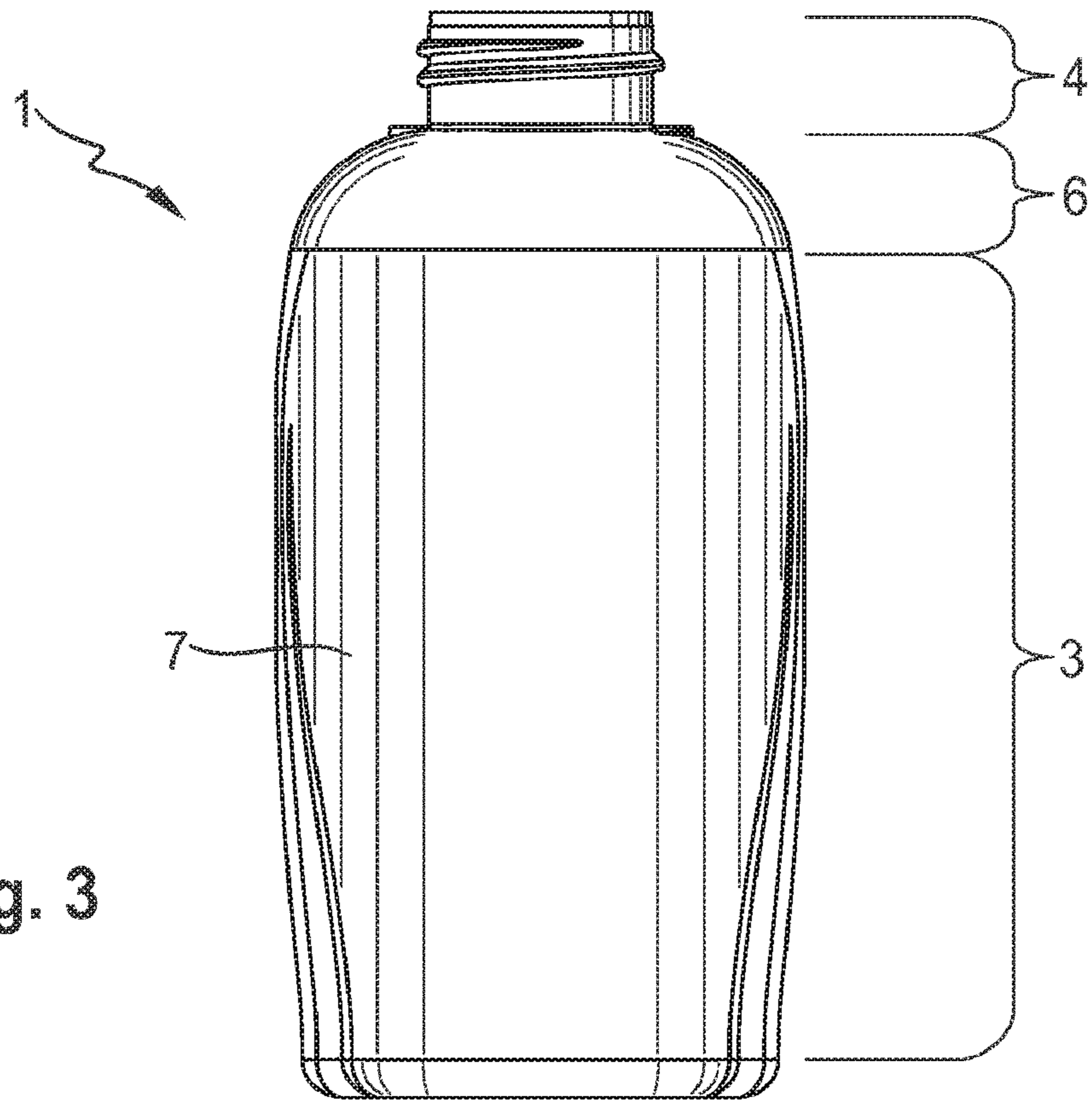

Fig. 3

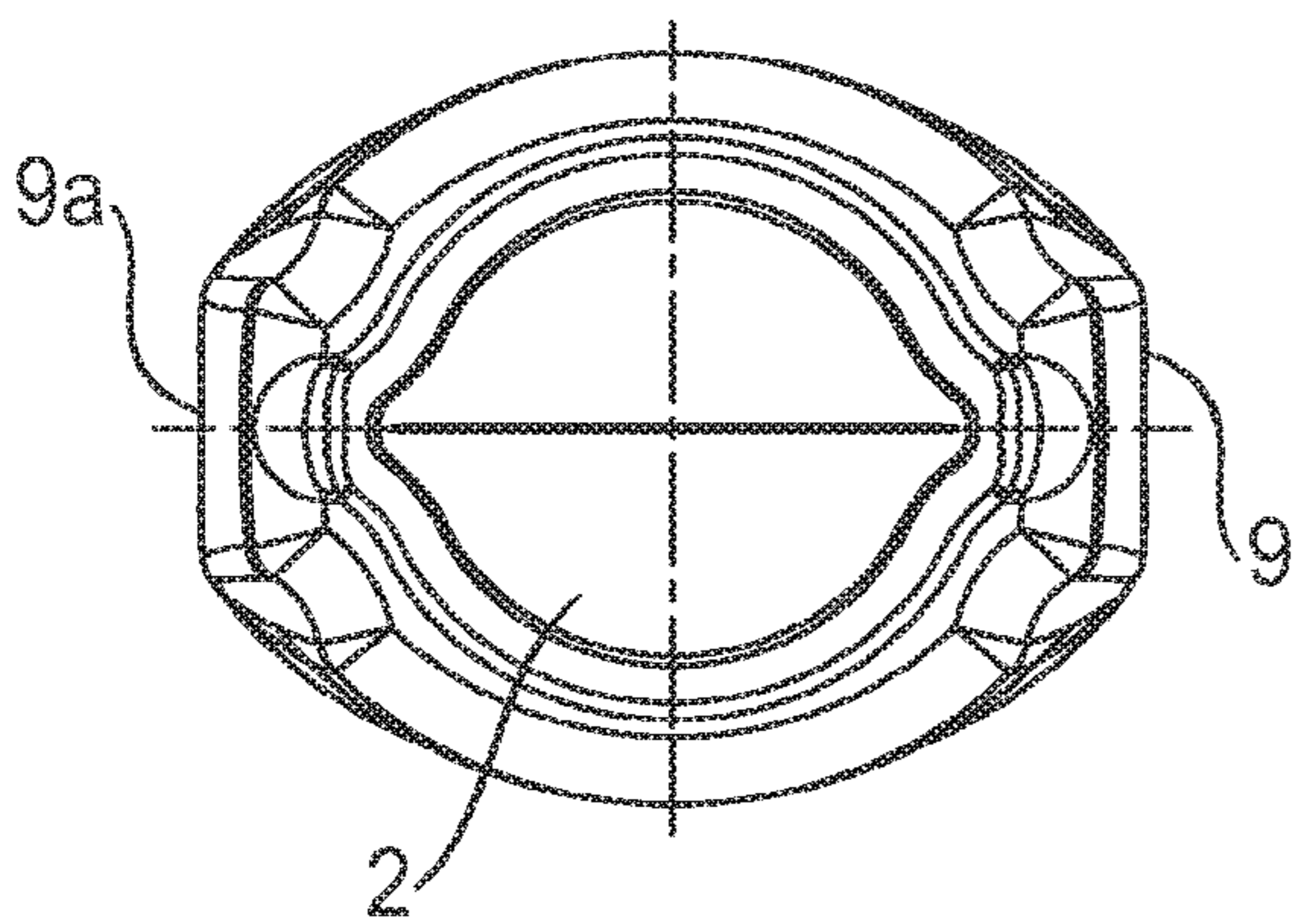

Fig. 4

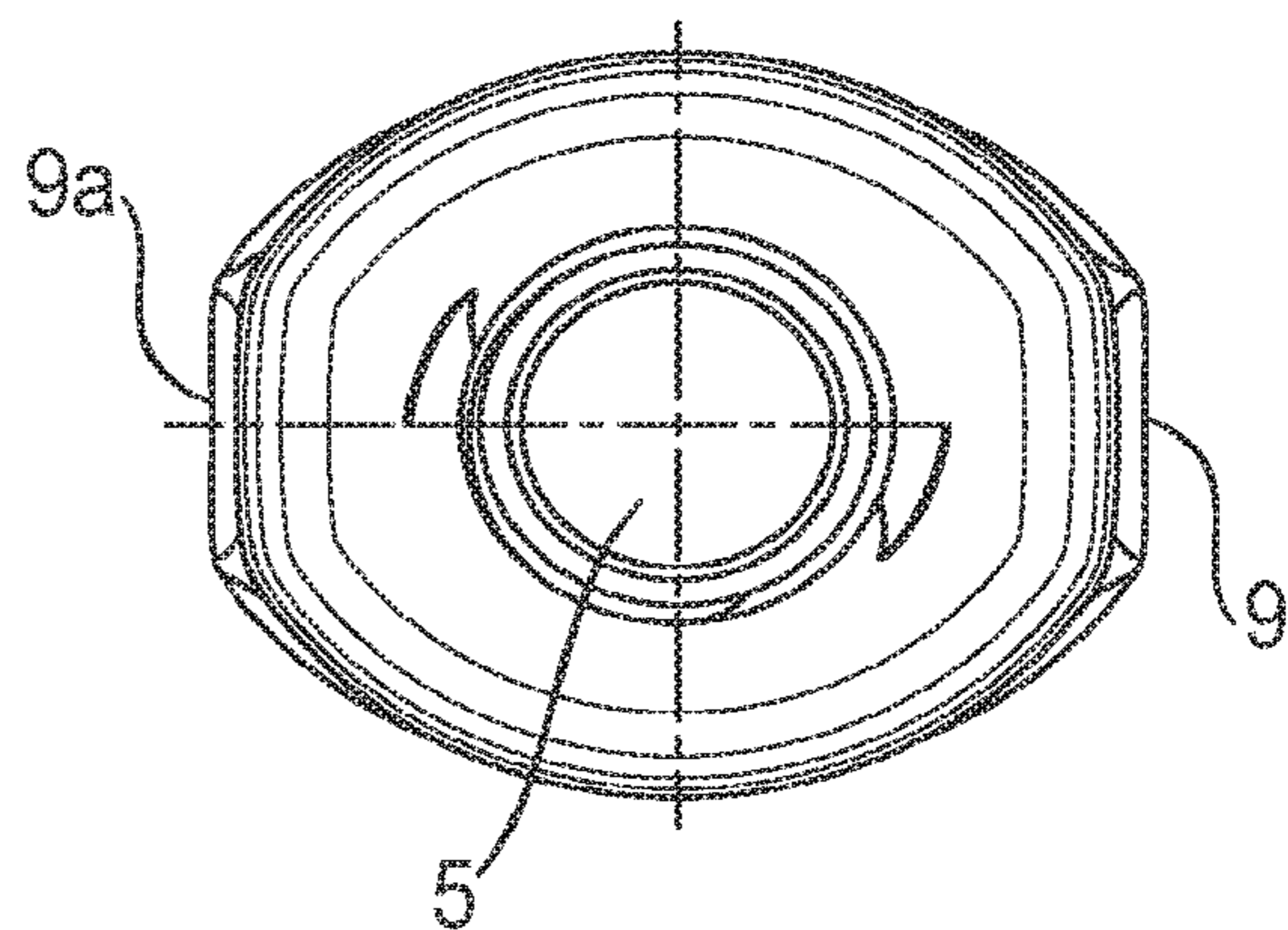

Fig. 5

**1****BEAUTY CARE PRODUCT****CROSS REFERENCE TO RELATED APPLICATIONS**

This is a nonprovisional continuation application claims the benefit of U.S. patent application Ser. No. 16/850,850, filed Apr. 16, 2020, which application is a continuation of U.S. patent application Ser. No. 16/560,292, filed Sep. 4, 2019, which application is a continuation of U.S. patent application Ser. No. 15/042,288, filed Feb. 12, 2016, which application is a division of U.S. patent application Ser. No. 14/265,722, filed Apr. 30, 2014, which application claims priority to U.S. Provisional Patent Application Ser. No. 61/820,346 filed on May 7, 2013, which applications and publications are incorporated herein by reference in their entirety. European Application Serial No. 131910051 also claims priority to U.S. Provisional Patent Application Ser. No. 61/820,346 filed on May 7, 2013, which application and publication is incorporated herein by reference in its entirety.

**FIELD OF THE INVENTION**

The present invention relates to a beauty care product comprising a sealable plastic container, a sealing means and a beauty care component; to a kit comprising said product thereof; to a method of manufacturing said product; and to a method of using said product for application onto skin and/or hair. The present invention provides a product, the container of which is resistant to random, uncontrolled deformation under a substantial pressure differential between the environment and inside the container, yet having an affordable cost of manufacture and/or being appealing to the consumer.

**BACKGROUND OF THE INVENTION**

Beauty care compositions, particularly hair coloring and/or bleaching compositions and/or heat-generating cosmetic compositions, may involve reactive chemistry, as they comprise ingredients undergoing a chemical reaction when placed in contact with each other. For example, oxidative hair color compositions comprise a primary precursor (also called coupler), a secondary precursor (also called developer) and an oxidizing agent such as ammonia. When mixed together, a chemical reaction occurs so that a dye is formed.

Such chemical reaction is wanted upon application onto hair, but not before. For avoiding the chemical reaction to occur prematurely such as upon manufacture and/or upon storage, these ingredients are usually comprised within different components, such as a first component (also called a tint) comprising the primary precursor and a second component (also called the developer) comprising the secondary precursor. These components may be sold as a kit and be packaged individually in any suitable packaging, wherein these kits comprise at least two components to be mixed extemporaneously i.e. shortly before application onto hair.

Professional hairdressers are usually mixing the different components using a bowl and a spatula. Untrained users such as consumers coloring their hair by themselves are not willing to mix the components in a bowl, as the mixture obtained may lack homogeneity, leading afterwards to an uneven hair coloration and also because such process is uneasy to achieve, and may lead to staining the area where the mixing is taking place e.g. the sink, the bathtub, and/or the floor. For avoiding such drawbacks, hair coloring and/or

**2**

bleaching kits are usually provided with at least one squeezable plastic container comprising about 70% or less of a component upon storage. At least one of the other components is poured into the container, mixed together with its content, and the resulting hair coloring and/or bleaching composition is applied onto hair by squeezing the plastic container.

Such type of containers while being convenient upon use, have shown drawbacks upon storage. Indeed, they usually comprise relatively thin panels in order to be squeezable i.e. deformable upon application of localized pressure onto the container by hand without excessive force. However, as these containers are filled with about 70% or less of a component, there is a substantial residual volume filled with gas e.g. ambient air at the place of manufacture. Upon certain circumstances such as a change of temperature and/or a change of altitude, there may have a significant pressure differential between the environment and inside the container. Such differential often leads to an uncontrolled, random deformation of the container. This is unwanted as the container may not be appealing to the consumer, may look defect and/or may even induce the leaking of its content and/or its breakage.

Different solutions have been provided for avoiding these drawbacks. For example, containers comprising thicker labels and/or labels made of more rigid plastics have been provided. These containers require however an increased force for being squeezed, which is inconvenient upon use by the consumer. Containers having pressure-regulating means have also been provided. Such means are usually sophisticated and therefore expensive to be manufactured. It also usually requires at least one additional process step for affixing them onto the container and/or the sealing means. This drives the cost of manufacture up, and impacts negatively on the price of sale of the hair coloring and/or bleaching products and/or kits.

There is a desirable need therefore of providing a hair coloring and/or bleaching product comprising a squeezable plastic container containing upon storage about 70% or less of a hair coloring and/or bleaching component, which is resistant to random, uncontrolled deformation under a substantial pressure differential between the environment and inside the container. There is also the desirable need for providing a hair coloring and/or bleaching product comprising a squeezable plastic container being resistant to uncontrolled deformation, which has an affordable cost of manufacture. There is also the desirable need for providing a hair coloring and/or bleaching product comprising a squeezable plastic container being resistant to uncontrolled deformation, which is appealing to the consumer yet easy to use.

**SUMMARY OF THE INVENTION**

In one aspect, the present invention relates to a beauty care product comprising:

- (a) a sealable plastic container **1** comprising a base section **2**, a body section **3**, and a neck section **4** forming an aperture **5**; said sections delimiting an inner reservoir;
- (b) a sealing means, affixed onto the neck section **4** of the container **1**;
- (c) a beauty care component, contained within the reservoir of the container **1**;

wherein the reservoir comprises upon storage no more than about 70% of the component by total volume of the reservoir, the remaining volume being filled with gas; wherein the body section **3** is four-paneled and comprises a non-collapsible squeezable front panel **7**, two symmetrical collapsible

side panels 9 and 9a and a non-collapsible squeezable back panel 8; wherein the ratio of the average thicknesses between front and/or back panels 7,8 and the side panels 9,9a is at least 2:1. In at least one embodiment, the side panels 9,9a are temporarily deformable in response to a substantial pressure differential between the environment and inside the reservoir of the container 1.

In a second aspect, the present invention relates to a beauty care kit comprising said product, and at least one additional product. In a third aspect, the present invention relates to a method for manufacturing said product. In a fourth aspect, the present invention relates to a method of using said product for application onto hair and/or skin.

#### BRIEF DESCRIPTION OF THE DRAWINGS

FIG. 1 is a perspective view from above of the container 1, including the front panel and one of the side panel (right).

FIG. 2 is a front view of the container 1.

FIG. 3 is a side view (right) of the container 1.

FIG. 4 is a bottom view of the container 1.

FIG. 5 is a top view of the container 1.

#### DETAILED DESCRIPTION OF THE INVENTION

In this document, including in all embodiments of all aspects of the present invention, the following definitions apply unless specifically stated otherwise. All percentages are by weight of the total composition. All ratios are weight ratios. References to 'parts' e.g. a mixture of 1 part X and 3 parts Y, is a ratio by weight. "QS" or "QSP" means sufficient quantity for 100% or for 100 g. +/- indicates the standard deviation. All ranges are inclusive and combinable. The number of significant digits conveys neither a limitation on the indicated amounts nor on the accuracy of the measurements. All numerical amounts are understood to be modified by the word "about". All measurements are understood to be made at 23° C. and at ambient conditions, where "ambient conditions" means at 1 atmosphere (atm) of pressure and at 50% relative humidity. "Relative humidity" refers to the ratio (stated as a percent) of the moisture content of air compared to the saturated moisture level at the same temperature and pressure. Relative humidity can be measured with a hygrometer, in particular with a probe hygrometer from VWR® International. Herein "min" means "minute" or "minutes". Herein "mol" means mole. Herein "g" following a number means "gram" or "grams". All weights as they pertain to listed ingredients are based on the active level and do not include carriers or by-products that may be included in commercially available materials. Herein, "comprising" means that other steps and other ingredients can be in addition. "Comprising" encompasses the terms "consisting of" and "consisting essentially of". The compositions, formulations, methods, uses, kits, and processes of the present invention can comprise, consist of, and consist essentially of the elements and limitations of the invention described herein, as well as any of the additional or optional ingredients, components, steps, or limitations described herein. Embodiments and aspects described herein may comprise or be combinable with elements, features or components of other embodiments and/or aspects despite not being expressly exemplified in combination, unless an incompatibility is stated. "In at least one embodiment" means that one or more embodiments of the present invention has/have the subsequently described feature.

"Molecular weight" or "M.Wt." or "MW" and grammatical equivalents mean the number average molecular weight.

"Water-soluble" refers to any material that is sufficiently soluble in water that when dissolved forms a clear solution to the naked eye at a concentration of 0.1 g of the material in 1 Litre of deionized water at 25° C. and 1 atm pressure. The term "water-insoluble" refers to any material that is not "water-soluble".

"Substantially free from" or "substantially free of" means less than about 1%, or less than 0.8%, or less than 0.5%, or less than 0.3%, or about 0%, by total weight of the composition or formulation.

"Hair" means mammalian keratin fibres including scalp hair, facial hair and body hair. It includes such hair still being attached to a living subject and also hair that has been removed therefrom such as hair swatches and hair on a doll/mannequin. In an embodiment, "hair" means human hair. "Hair shaft" or "hair fibre" means an individual hair strand and may be used interchangeably with the term "hair."

"Cosmetically acceptable" means that the compositions, formulations or components described are suitable for use in contact with human keratinous tissue without undue toxicity, incompatibility, instability, allergic response, and the like. All compositions and formulations described herein which have the purpose of being directly applied to keratinous tissue are limited to those being cosmetically acceptable.

"Derivatives" includes but is not limited to, amide, ether, ester, amino, carboxyl, acetyl, acid, salt and/or alcohol derivatives of a given compound, in at least one embodiment, "derivatives thereof" means the amide, ether, ester, amino, carboxyl, acetyl, acid, salt and alcohol derivatives.

"Monomer" means a discrete, non-polymerised chemical moiety capable of undergoing polymerisation in the presence of an initiator or any suitable reaction that creates a macromolecule e.g. such as polycondensation, polyaddition, anionic or cationic polymerization. "Unit" means a monomer that has already been polymerised i.e. is part of a polymer.

"Polymer" means a chemical formed from the polymerisation of two or more monomers. The term "polymer" shall include all materials made by the polymerisation of monomers as well as natural polymers. Polymers made from only one type of monomer are called homopolymers. Herein, a polymer comprises at least two monomers. Polymers made from two or more different types of monomers are called copolymers. The distribution of the different monomers can be random, alternating or block-wise (i.e. block copolymer). The term "polymer" used herein includes any type of polymer including homopolymers and copolymers,

"Kit" means a package comprising a plurality of components. "Kit" may be referred to as "kit-of-parts". An example of a kit is, for example, a first composition and a separately packaged second composition and optionally application instructions.

As used herein, when describing the container according to the present invention, the expressions "bottom" and "top" are relative to the orientation of the product when resting onto a surface so that the base section of the container (also called bottom section) is orientated toward the bottom of the product and the neck section and sealing means are orientated toward the top of product. Likewise, the expressions "vertical/vertically" and "horizontal/horizontally" are relative to the orientation of the product when resting onto a surface, said surface being horizontal.

As used herein, when describing the panels forming the body section of the container, "front", "back" and "side" are

## 5

relative to the panel onto which the front label is attached, said front label being the label displaying information about the product to be seen first by the consumer when standing on the supermarket shelf, including, but not limited to, the brand name, logo, slogan, illustrations and/or pictures, information such as the container size, etc.

As used herein, “beauty care products” means any products being suitable for application onto keratin substrates, including hair, skin, eyebrows, eyelashes, lips, and nails. Beauty care products may include personal care products, make-up products, shave care products and hair care products. Personal care products may include personal and/or facial cleansing products. Make-up products may include mascaras, foundations and enamels. Hair care products may include shampoos, conditioning compositions, styling compositions and hair color compositions.

In a first aspect, the present invention relates to a product comprising a sealable plastic container **1**, said container **1** comprising a base section **2**, a body section **3**, and a neck section **4**.

The base section **2** allows the container **1** to rest onto a surface, e.g. a supermarket shelf and/or on the bathtub or sink contours. The neck section **4** forms an aperture **5**, suitable for pouring a liquid into and/or out of the container **1**. The container **1** may also contain a shoulder section **6**, joining the body section **3** to the neck section **4**.

The base section **2**, the body section **3**, the neck section **4**, and optionally the shoulder section **6** delimit an inner reservoir (not shown). This reservoir comprises a total volume of from about 20 ml to about 1500 ml, alternatively from about 50 ml to about 1000 ml, alternatively from about 75 ml to about 500 ml, alternatively from about 100 ml to about 250 ml, alternatively from about 160 ml to about 170 ml.

A beauty care component (not shown), particularly a hair coloring and/or bleaching component, as described herein-after, is contained within the reservoir. The reservoir comprises upon storage no more than about 70%, no more than about 50%, alternatively from about 30% to about 50%, of said component by total volume of the reservoir. In another embodiment, the reservoir comprises upon storage less than about 30% and/or at least about 5% of said component by total volume of the reservoir. In still another embodiment, the reservoir (container) is substantially free of any component upon storage.

After filling and sealing, as the inner reservoir is not filled entirely with said component, the reservoir is left with a remaining volume. In a preferred embodiment, said remaining volume is filled with a gas. The gas may be selected from oxygen, nitrogen, carbon dioxide, ambient air, and mixtures thereof; alternatively a gas being ambient air; alternatively a gas being ambient air at a pressure from about 70 kPa to about 101 kPa; alternatively a gas being ambient air at a pressure from about 70 kPa to about 101 kPa and at temperature of from about 15° C. to about 45° C. In at least one embodiment, the remaining volume of the reservoir is filled with ambient air. As used herein, “ambient air” means the ambient air at the time of manufacture of the product, particularly the time at which the container **1** is filled with the component, and subsequently sealed. Without wishing to be bound by any theory, it is believed that, because the reservoir of the container **1** comprises upon manufacture and/or storage a remaining volume filled with a gas at a certain pressure and temperature, this container **1** may be subject to deformation forces, such as extension and/or collapsible forces, whenever a substantial pressure differential between the environment and the reservoir remaining

## 6

volume occurs. As used herein, “a substantial pressure differential” means a difference of pressure of from about 0.01 kPa to about 30 kPa between the environment and the reservoir remaining volume. Such pressure differential may be induced by a change of temperature inside the reservoir and/or a change of atmospheric pressure in the environment, e.g. because of a change of altitude.

The body section **3** is four-paneled. It comprises a front panel **7**, a back panel **8**, and two side panels **9** and **9a**. These panels are substantially vertical.

The front and back panels **7,8** are non-collapsible and squeezable panels. As used herein, “noncollapsible” means that these panels are not prone to a passive deformation when the container **1** is subject to a substantial pressure differential. As used herein, “squeezable” means that these panels are prone to an active deformation when subject to a substantial force e.g. a force of at least 0.113 Joules (1 in-lb), alternatively from about Joules (1 in-lb) to about 4.519 Joules (40 in-lb), alternatively from about 1.130 Joules (10 in-lb) to about 3.390 Joules (30 in-lb), exerted locally onto these panels, preferably a force exerted by the consumer hand. At least one of the front and back panels **7,8** may be functional panels, alternatively the front panel **7** may be a functional panel or both panels **7** and **8** may be functional panels. As used herein, “functional” means that the panels are the support for the labels, comprising various information including, but not limited to, the brand name, logo, slogan, illustrations and/or pictures, information such as the container size, ingredient list, and/or regulatory requirements. The front and/or the back panels **7,8** may have an average thickness of from about 0.50 mm to about 3 mm, alternatively from about 0.50 mm to about 1.5 mm, alternatively from about 0.55 mm to about 1.15 mm. The front and back panels **7,8** may have substantially the same average thickness, alternatively an average thickness differing from about +/-10%, alternatively from about +/-5%, alternatively from about +/-1%.

Thickness can be measured using a caliper device. Average thickness may be measured by taking at least 10 measurements approximately evenly distributed across the area of the panel and then calculating the mean thickness i.e. average thickness, which is measured in millimeters i.e. mm. In at least one embodiment, the average thickness has a standard deviation of less than about +/-10%, or less than about +/-5%, or less than about +/-1%.

The side panels **9** and **9a** are collapsible panels. As used herein, “collapsible” means that these panels are prone to a passive deformation when the container is subject to a substantial pressure differential. In at least one embodiment, “substantial pressure differential” means a pressure differential of at least 2%, or at least 5%, or at least 10%, or at least 20% measured in kPa. Preferably, the side panels **9** and **9a** are collapsible substantially over their entire surface. In a preferred embodiment, these panels are not intended to be squeezable/squeezed. These panels may be non-functional panels, i.e. these panels may not be the support of any label. The side panels **9** and **9a** may have an average thickness of from about 0.25 mm to about 1.5 mm, alternatively from about 0.25 mm to about 0.55 mm. Both side panels **9** and **9a** may have substantially the same average thickness, alternatively an average thickness differing from about +/-10%, alternatively from about +/-5%, alternatively from about +/-1%.

In order for the front and back labels **7,8** and the side labels **9,9a** to exhibit different properties vis-à-vis collapsibility and squeezability under normal conditions of use, and particularly for obtaining a container having non-collaps-

ible, squeezable front and back panels **7,8** and collapsible side panels **9,9a**, the inventors have found that these panels should exhibit a specific differential of average thicknesses. The ratio of the average thicknesses between the front and/or back panels **7,8** and the side panels **9,9a** is at least about 2:1, alternatively from about 2:1 to about 5:1, alternatively from about 2:1 to about 3:1, alternatively from about 2:1 to about 2.5:1. Average thickness is measured in millimeters i.e. mm, and thus the ratio of average thickness refers to mm.

In at least one embodiment, the body section **3** is an extended hollow body section. In a preferred embodiment, the body section **3** has a non-cylindrical, non-rectangular and non-squared cross-sectional shape (horizontal cross-section at half height). The body section **3** may have an overall elliptical cross-sectional shape, with the tangents at the panel edges between the side panel **9,9a** and the front and/or the back panels **7,8** forming an angle of more than 90° and less than 180°, alternatively from about 100° to about 150°, alternatively from about 110° to about 140°.

In at least one embodiment, the front and/or back panels **7,8** are substantially non-planar relative to a horizontal plane, preferably they are substantially convex in shape relative to a horizontal plane. The front and/or back panels **7,8** may have a radius from about 10 mm to about 40 mm, alternatively from about 10 mm to less than about 20 mm, alternatively from about 20 mm to less than about 30 mm, alternatively from about 30 mm to about 40 mm. The front and/or back panels **7,8** may also be substantially planar relative to a vertical plane.

In at least one embodiment, the side panels **9,9a** are substantially non-planar relative to a horizontal plane, preferably they are substantially concave in shape relative to a horizontal plane. The side panels **9,9a** may have a radius from about 10 mm to about mm, alternatively from about 10 mm to less than about 20 mm, alternatively from about 20 mm to less than about 30 mm, alternatively from about 40 mm to less than about 55 mm. The side panels **9,9a** may also be substantially planar relative to a vertical plane.

In at least one embodiment, the sealable plastic container **1** has a substantially symmetrical shape relative to an axis formed by the center of the aperture and the center of the bottom base section **2**.

The container **1** may have a width of from, about 20 mm to about 105 mm, alternatively from about 20 mm to about 30 mm, alternatively from about 40 mm to about mm, alternatively from about 90 mm to less than about 105 mm. In at least one embodiment, the width is the average width. Average width may be measured by taking at least 10 measurements approximately evenly distributed across and then calculating the mean width i.e. average width, which is measured in millimeters i.e. mm. In at least one embodiment, the average width has a standard deviation of less than about +/-10%, or less than about +/-5%, or less than about +/-1%.

The container **1** may also have a length of from about 20 mm to 80 mm, alternatively from about 20 mm to about 30 mm, alternatively from about 40 mm to about mm, alternatively from about 70 mm to about 80 mm. In at least one embodiment, the length is the average length. Average length may be measured by taking at least 10 measurements approximately evenly distributed across and then calculating the mean length i.e. average length, which is measured in millimeters i.e. mm. In at least one embodiment, the average length has a standard deviation of less than about +/-10%, or less than about +/-5%, or less than about +/-1%.

The container **1** may also have a height of from about 50 mm to about 300 mm, alternatively from about 50 mm to

about 70 mm, alternatively from about 100 mm to about 120 mm, alternatively from about 250 mm to about 270 mm, the height being measured from the bottom of the base section **2** to the top of the neck section **4**, excluding the sealing means. In at least one embodiment, the height is the average height. Average height may be measured by taking at least 10 measurements approximately evenly distributed across and then calculating the mean height i.e. average height, which is measured in millimetres i.e. mm. In at least one embodiment, the average height has a standard deviation of less than about +/-10%, or less than about +/-5%, or less than about +/-1%.

The container **1** is made of plastics, alternatively of cosmetic-grade plastics. The base section **2**, the body section **3**, the neck section **4** and optionally the shoulder section **6** may be made of the same plastics. The container **1** may be made of plastics selected from the group consisting of polyethylene terephthalate (PET), polyethylene (PE), high density polyethylene (HDPE), low density polyethylene (LDPE), polyvinyl chloride (PVC), polyvinylidene chloride (PVDC), polypropylene (PP), polystyrene (PS), high-impact polystyrene (HIPS), polyamides (PA) (Nylons), acrylonitrile butadiene styrene (ABS), polyethylene/acrylonitrile butadiene styrene (PE/ABS), polycarbonate (PC), polycarbonate/acrylonitrile butadiene styrene (PC/ABS), polyurethanes (PU), acrylonitrile butadiene styrene (ABS), Celluloid, Cellulose acetate, ethylene-vinyl acetate (EVA), ethylene vinyl alcohol (EVAL), liquid crystal polymer (LCP), polyacetal (POM or Acetal), polyacrylates (Acrylic), polyacrylonitrile (PAN or Acrylonitrile), polyamide-imide (PAI), polyaryletherketone (PAEK or Ketone), polybutadiene (PBD), polybutylene (PB), polybutylene terephthalate (PBT), polycyclohexylene dimethylene terephthalate (PCT), polyhydroxyalkanoates (PHAs), polyketone (PK), polyester, polyethylene (PE) including low density (LDPE) and high density (HDPE) versions, polyetheretherketone (PEEK), polyetherimide (PEI), polyethersulfone (PES), polyethylenechlorinates (PEC), polyimide (PI), polylactic acid (PLA), polymethylpentene (PMP), polyphenylene oxide (PPO), polyphenylene sulfide (PPS), polyphthalamide (PPA), polysulfone (PSU), and mixtures thereof. The container **1** may alternatively be made of plastics selected from, polyolefines; alternatively from the group consisting of high-density polyethylene (HDPE), low density polyethylene (LDPE), polypropylene (PP), polyethylene terephthalate (PET), derivatives thereof, and mixtures thereof; alternatively from plastics being high-density polyethylene (HDPE). Commercially available HDPE are provided by Exxon under the trade name AS55-003. In a preferred embodiment, the container **1** is made of high-density polyethylene and is substantially free of polyethylene terephthalate. In at least one embodiment, the container **1** comprises at least about 80%, or at least about 85%, or at least about 90%, or at least about 95% polyethylene.

The product comprises a sealing means (not shown in figures). In at least one embodiment, the sealing means is suitable for impermeably sealing the container **1** upon storage. Any suitable sealing means may be used. The sealing means may be a lid, a cap, an operculum or a nozzle. The sealing means may be permanently- or releasably-affixed onto the neck section **4** of the container **1**. Preferably, the sealing means is releasably-affixed onto the neck section **4** of the container **1**.

The product may further comprise at least one label (not shown in figures), alternatively two labels, to be affixed onto the container **1**. The labels may be selected from front labels and/or back labels. The front label is usually an aesthetical



appealing label, showing for example the brand name, logo, slogan, illustrations and/or pictures. The back label is usually informative, showing for example information such as the container size, INCI list, regulatory requirements, and instructions on how to use the product and/or the component. In a preferred embodiment, the front label is affixed to the front panel 7 and/or the back label is affixed onto the back panel 8. The front and/or back panels may be affixed onto their respective panels 7,8 using any suitable means, such as gluing.

The product comprises a beauty care component (not shown in figures). Preferably, the product comprises a hair coloring and/or bleaching component. The component may comprise a source of an oxidizing agent. Any oxidizing agent known in the art may be used. Preferred oxidizing agents are water-soluble peroxygen oxidizing agents. As used herein, "water-soluble" means that in standard conditions at least about 0.1 g, alternatively about 1 g, alternatively about 10 g of the oxidizing agent can be dissolved in 1 litre of deionized water at 25° C. The component may comprise a total amount of oxidizing agent ranging from about 3% to about 12%, by weight of the total component. Suitable water-soluble oxidizing agents include, but are not limited to: inorganic peroxygen materials capable of yielding hydrogen peroxide in an aqueous solution; alternatively hydrogen peroxide, inorganic alkali metal peroxides, organic peroxides, inorganic perhydrate salt bleaching compounds, and mixtures thereof; alternatively hydrogen peroxide, percarbonates, persulphates, and mixtures thereof. In at least one embodiment, the beauty care component comprises hydrogen peroxide (H<sub>2</sub>O<sub>2</sub>). The beauty care component may be a developer composition. The developer composition may be based on any desired formulation chassis, including any commercial product, for example an oil-in-water emulsion. In at least one embodiment, the developer composition comprises from about 6% to about 9% H<sub>2</sub>O<sub>2</sub> relative to the total weight of the developer composition. In at least one embodiment, the component is a hair coloring and/or hair bleaching component comprising a total amount of oxidizing agent ranging from about 3% to about 12%, by weight of the total component. A commercial example is the Welloxon® Emulsion with respectively about 6% and about 9% H<sub>2</sub>O<sub>2</sub>, marketed by Wella and comprising as INCI ingredients: Water, H<sub>2</sub>O<sub>2</sub>, Cetearyl Alcohol, Cetareth-25, Salicylic Acid, Phosphoric Acid, Disodium Phosphate, Etidronic Acid.

In a second aspect, the present invention relates to a beauty care kit, preferably a hair coloring and/or bleaching kit. The kit comprises the beauty care product as described hereinbefore. It also comprises at least an additional product, alternatively from about 2 to about 4 additional products, alternatively 2 or 3 additional products. The additional products may be selected from the group consisting of a product comprising a packaged component, a tool, an instruction sheet, or combinations thereof. The packaged component may be selected from a tint component comprising at least one primary precursor, a component comprising at least a secondary precursor, a conditioning component comprising at least one conditioning active ingredient. Said components may be packaged in any suitable packaging, alternatively from a sealable container, optionally sealed with a sealable means; or a sachet. Said tool may be selected from any tool suitable for coloring and/or bleaching hair, alternatively from a comb, a spatula, a brush, a bowl for missing the components. The instruction sheet may comprise any suitable information, e.g. the step sequence, about on how to color and/or bleach hair with said kit. Any of the

disclosure in relation to the first aspect is also relevant to and compatible with the second aspect.

In a third aspect, the present invention relates to a process for manufacturing the product as described herein before. The container may be manufacture using any suitable process of manufacture. In a preferred embodiment, the container is manufactured by a process selected from blow molding, compaction plus sintering, compression molding, expandable bead molding, extrusion blow molding, foam molding, injection molding, injection/stretch blow molding, laminating, reaction injection molding, matched mold, matrix molding, plastic moulding, pressure plug assist molding, rotational molding (or rotomolding), transfer molding, thermoforming, vacuum forming, vacuum plug assist molding; alternatively from an extrusion process, alternatively by a continuous extrusion blow molding process. Any of the disclosure in relation to the first and second aspects is also relevant to and compatible with the third aspect.

In a fourth aspect, the present invention relates to a method for coloring and/or bleaching hair. The method comprises the steps of:

- (a) providing a first product comprising: a sealable plastic container comprising a base section, a body section, and a neck section forming an aperture; said sections delimitating an inner reservoir; a sealing means, affixed onto the neck section of the container; a developer component, contained within the reservoir of the container; wherein the reservoir comprises upon storage no more than about 70% of the component by total volume of the reservoir, the remaining volume being filled with gas; wherein the body section is four-paneled and comprises a non-collapsible squeezable front panel, two symmetrical collapsible side panels and a non-collapsible squeezable back panel; wherein the ratio of the average thicknesses between front and/or back panels and the side panels is at least 2:1;
- (b) providing an additional product being a packaged component selected from a tint component comprising at least one primary precursor, a component comprising at least one secondary precursor, or combination thereof;
- (c) pouring the additional product into the reservoir remaining volume of the container of the first product;
- (d) mixing the developer component homogeneously with the additional product
- (e) applying the mixed composition onto hair,

Any of the disclosure in relation to the first, second and third aspects is also relevant to and compatible with the fourth aspect.

#### EXAMPLE

The following examples are for illustration and not intended to limit the claim scope. A beauty care product according to the present invention was obtained starting from a commercially available high-density polyethylene (HDPE) provided by Exxon under the tradename AS55-003 and using an extrusion blow molding process.

The sealable plastic container 1 obtained—as shown in FIG. 1—exhibits the following characteristics:

- weight (undecorated): 12.0 g+/-1.5 g;
- height (overall): 114.45 mm+/-1.52 mm;
- width (max): 51 mm+/-1.52 mm;
- depth (max): 44.5 mm+/-0.4 mm;
- overflow capacity (OFC): 165 mL+/-5 mL;
- side panels thickness (average): 0.39 mm
- front panel thickness (average): 1.04 mm

## 11

back panel thickness (average): 1.04 mm  
 difference in wall thickness between front and back panel  
 (measured at the center): 0.0 mm+/-0.1 mm;  
 difference in wall thickness between two symmetrical side  
 panels (measured at the center): 0.0 mm+/-0.1 mm; 5  
 ratio of the average thicknesses between front and/or back  
 panels and the side panels: 2.67 mm;  
 total volume of the inner reservoir: 165 ml;  
 I dimension (inner diameter of the neck section): 17.02  
 mm+/-0.12 mm; 10  
 T dimension (outside diameter of the neck section): 23.66  
 mm+/-0.2 mm;  
 H dimension (height of the neck section) 12.34 mm+/-0.4  
 mm;

The sealing means is non-vented closure to be screwed 15  
 onto the screw thread of the neck section of the container.

The beauty care component is a developer component,  
 conventionally used in the field of hair coloring and/or  
 bleaching hair. This developer is Welloxon 6%. The volume  
 of the developer packaged into the container is of about 60 20  
 ml, i.e. about 36% of the total volume of the inner reservoir  
 of the container. The remaining volume filled with ambient  
 air at the place of manufacture is therefore of about 64% of  
 the total volume of the inner reservoir. The beauty care  
 product is manufactured at a place of manufacture wherein 25  
 the ambient temperature is about 21° C. to about 26° C. and  
 the atmospheric pressure is about kPa to about 84 kPa.

Upon transportation and/or storage, despite some changes  
 of ambient temperature and/or atmospheric pressure, the  
 container shows satisfactory resistance to random, uncon- 30  
 trolled deformation because of the presence of two sym-  
 metrical collapsible side panels having a specific average  
 thickness ratio relative to the front and/or back panels.

The dimensions and values disclosed herein are not to be  
 understood as being strictly limited to the exact numerical 35  
 values recited. Instead, unless otherwise specified, each such  
 dimension is intended to mean both the recited value and a  
 functionally equivalent range surrounding that value. For  
 example, a dimension disclosed as "40 mm" is intended to  
 mean "about 40 mm." Every document cited herein, includ- 40  
 ing any cross referenced or related patent or application and  
 any patent application or patent to which this application  
 claims priority or benefit thereof, is hereby incorporated  
 herein by reference in its entirety unless expressly excluded  
 or otherwise limited. The citation of any document is not an 45  
 admission that it is prior art with respect to any invention  
 disclosed or claimed herein or that it alone, or in any  
 combination with any other reference or references, teaches,  
 suggests or discloses any such invention. Further, to the  
 extent that any meaning or definition of a term in this 50  
 document conflicts with any meaning or definition of the  
 same term in a document incorporated by reference, the  
 meaning or definition assigned to that term in this document  
 shall govern. While particular embodiments of the present  
 invention have been illustrated and described, it would be 55  
 obvious to those skilled in the art that various other changes  
 and modifications can be made without departing from the  
 spirit and scope of the invention. It is therefore intended to  
 cover in the appended claims all such changes and modifi-  
 cations that are within the scope of this invention. 60

What is claimed is:

1. A beauty care product comprising:

- (a) a sealable plastic container comprising a base section,  
 a body section, and a neck section forming an aperture;  
 said sections delimiting an inner reservoir; 65
- (b) a sealing means, affixed onto the neck section of the  
 container;

## 12

(d) a beauty care component, contained within the reser-  
 voir of the container; wherein the reservoir comprises  
 upon storage nor more than about 70% of the beauty  
 care component by total volume of the reservoir, the  
 remaining volume being filled with gas; wherein the  
 body section is four-paneled and comprises a non-  
 collapsible squeezable front panel, two symmetrical  
 collapsible side panels and a non-collapsible squeez-  
 able back panel; wherein the front panel and back panel  
 have a first average thickness, and the two side panels  
 have a second average thickness which is less than the  
 first average thickness.

2. The product according to claim 1, wherein the side  
 panels are temporarily deformable in response to a substan-  
 tial pressure differential between the environment and inside  
 the reservoir of the container.

3. The product according to claim 1, wherein the front  
 and/or back panels have a first average thickness in the range  
 of about 0.25 mm to about 3 mm.

4. The product according to claim 1, wherein the side  
 panels have a second average thickness in the range of about  
 0.25 mm to about 1.5 mm.

5. The product according to claim 1, wherein the container  
 further comprises a shoulder section, joining the body sec-  
 tion to the neck section.

6. The product according to claim 1, wherein the reservoir  
 has a total volume of from about 20 ml to about 1500 ml.

7. The product according to claim 1, wherein the remain-  
 ing volume of the reservoir is filled with ambient air.

8. The product according to claim 1, wherein the body  
 section is an extended hollow body section; and wherein the  
 panels are substantially non-planar relative to the horizontal  
 plane.

9. The product according to claim 1, wherein the panels  
 are substantially non-planar relative to the horizontal plane. 35

10. The product according to claim 1, wherein the con-  
 tainer has a width of from about 20 mm to about 105 mm,  
 a length of from about 20 mm to about 80 mm, and a height  
 of from about 50 mm to about 300 mm.

11. The product according to claim 1, wherein the sealing  
 means is releasably-affixed onto the neck section of the  
 container.

12. The product according to claim 1, wherein the beauty  
 care component is a hair coloring and/or hair bleaching  
 component comprising a total amount of oxidizing agent  
 ranging from about 3% to about 13%, by weight of the total  
 beauty care component.

13. The product according to claim 1, wherein the con-  
 tainer is made of plastics.

14. The product according to claim 13, wherein the  
 container is made of high-density polyethylene.

15. The product according to claim 1, wherein the con-  
 tainer is made of high-density polyethylene and is substan-  
 tially free of polyethylene terephthalate.

16. The product according to claim 1, wherein the ratio of  
 the first average thickness to the second average thickness is  
 in the range of 2:1 to 5:1.

17. A beauty care product comprising:

- (a) a sealable plastic container comprising a base section,  
 a body section, and a neck section forming an aperture;  
 said sections delimiting an inner reservoir;
- (b) a sealing means, affixed onto the neck section of the  
 container;
- (d) a beauty care component, contained within the reser-  
 voir of the container; wherein the reservoir comprises  
 upon storage nor more than about 70% of the beauty  
 care component by total volume of the reservoir, the

remaining volume being filled with gas; wherein the body section is four-paneled and comprises a non-collapsible squeezable front panel, two symmetrical collapsible side panels and a non-collapsible squeezable back panel; wherein the front panel and back panel 5 have a first thickness, and the two side panels have a second thickness which is less than the first thickness.

**18.** The product according to claim **17**, wherein the side panels are temporarily deformable in response to a substantial pressure differential between the environment and the 10 inside of the reservoir of the container.

\* \* \* \* \*