



US011886363B2

(12) **United States Patent**
Longo et al.

(10) **Patent No.:** **US 11,886,363 B2**
(45) **Date of Patent:** ***Jan. 30, 2024**

(54) **QUALITY OF SERVICE POLICY SETS**

(56) **References Cited**

(71) Applicant: **NetApp, Inc.**, San Jose, CA (US)

U.S. PATENT DOCUMENTS

(72) Inventors: **Austino Longo**, Lafayette, CO (US);
Jared Cantwell, Boulder, CO (US)

5,138,697 A 8/1992 Yamamoto et al.
5,375,216 A 12/1994 Moyer et al.
(Continued)

(73) Assignee: **NetApp, Inc.**, San Jose, CA (US)

FOREIGN PATENT DOCUMENTS

(*) Notice: Subject to any disclaimer, the term of this patent is extended or adjusted under 35 U.S.C. 154(b) by 0 days.

EP 0726521 A2 8/1996
EP 1970821 A1 9/2008
(Continued)

This patent is subject to a terminal disclaimer.

OTHER PUBLICATIONS

(21) Appl. No.: **17/739,391**

Agrawal, et al., "Design Tradeoffs for SSD Performance," USENIX Annual Technical Conference, 2008, 14 Pages.
(Continued)

(22) Filed: **May 9, 2022**

Primary Examiner — Idriss N Alrobaye
Assistant Examiner — Henry W Yu

(65) **Prior Publication Data**

US 2022/0261362 A1 Aug. 18, 2022

(74) *Attorney, Agent, or Firm* — Jaffery Watson
Mendonsa & Hamilton LLP

Related U.S. Application Data

(57) **ABSTRACT**

(63) Continuation of application No. 17/203,094, filed on Mar. 16, 2021, now Pat. No. 11,327,910, which is a
(Continued)

Disclosed are systems, computer-readable mediums, and methods for managing client performance in a storage system. In one example, the storage system receives a request from a client to write data to the storage system. The storage system estimates, based on a system metric associated with the storage system reflecting usage of the storage system, a requested write QoS parameter for storing the data by the storage system during a first time period. The storage system further determines a target write QoS parameter for the client based on the estimated requested write QoS parameter and an allocated write QoS parameter for the client. Then, the storage system independently regulates read performance and write performance of the client using a controller to adjust the write performance toward the determined target write QoS parameter within the first time period based on feedback regarding the estimated requested write QoS parameter.

(51) **Int. Cl.**
G06F 13/16 (2006.01)
G06F 11/34 (2006.01)
(Continued)

(52) **U.S. Cl.**
CPC **G06F 13/1689** (2013.01); **G06F 3/061** (2013.01); **G06F 3/067** (2013.01);
(Continued)

(58) **Field of Classification Search**
CPC .. G06F 13/1689; G06F 11/3433; G06F 13/16; G06F 3/0659; G06F 3/067;
(Continued)

20 Claims, 11 Drawing Sheets

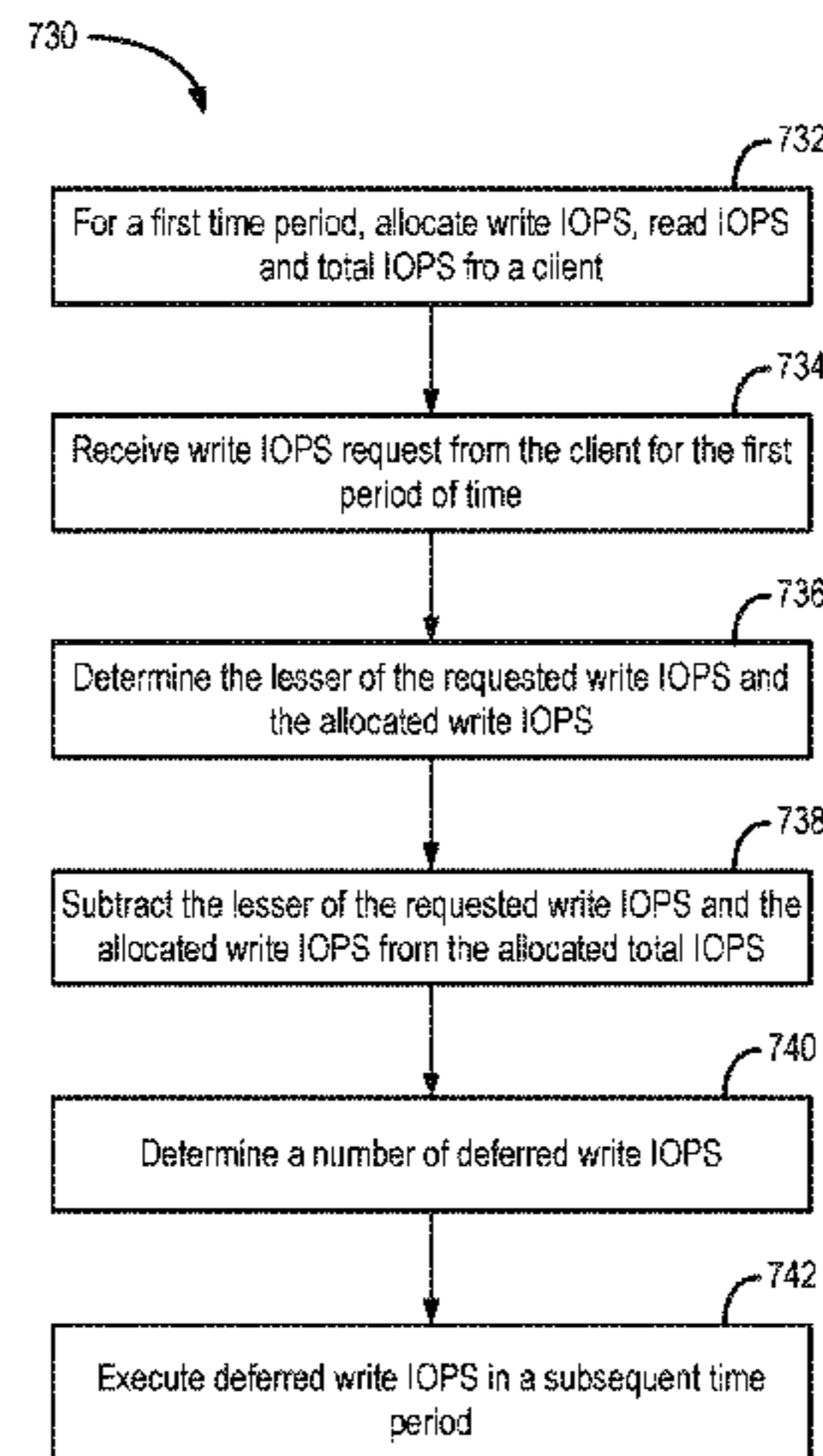

Related U.S. Application Data

continuation of application No. 16/867,418, filed on May 5, 2020, now Pat. No. 10,997,098, which is a continuation of application No. 15/270,973, filed on Sep. 20, 2016, now Pat. No. 10,642,763.

(51) **Int. Cl.**

G06F 3/06 (2006.01)
H04L 67/00 (2022.01)
G06F 13/40 (2006.01)
H04L 67/10 (2022.01)

(52) **U.S. Cl.**

CPC **G06F 3/0659** (2013.01); **G06F 11/3433** (2013.01); **G06F 13/16** (2013.01); **G06F 13/4068** (2013.01); **H04L 67/00** (2013.01); **H04L 67/10** (2013.01); **G06F 11/3419** (2013.01); **G06F 2206/1012** (2013.01)

(58) **Field of Classification Search**

CPC .. G06F 3/061; G06F 13/4068; G06F 11/3419; G06F 2206/1012; H04L 67/10; H04L 67/00

See application file for complete search history.

(56)

References Cited

U.S. PATENT DOCUMENTS

5,459,857 A 10/1995 Ludlam et al.
5,511,190 A 4/1996 Sharma et al.
5,542,089 A 7/1996 Lindsay et al.
5,592,432 A 1/1997 Vishlitzky et al.
5,603,001 A 2/1997 Sukegawa et al.
5,611,073 A 3/1997 Malpure et al.
5,734,859 A 3/1998 Yorimitsu et al.
5,734,898 A 3/1998 He
5,751,993 A 5/1998 Ofek et al.
5,860,082 A 1/1999 Smith et al.
5,864,698 A 1/1999 Krau et al.
5,890,161 A 3/1999 Helland et al.
5,937,425 A 8/1999 Ban
5,974,421 A 10/1999 Krishnaswamy et al.
5,991,862 A 11/1999 Ruane
6,047,283 A 4/2000 Braun et al.
6,067,541 A 5/2000 Raju et al.
6,081,900 A 6/2000 Subramaniam et al.
6,219,800 B1 4/2001 Johnson et al.
6,257,756 B1 7/2001 Zarubinsky et al.
6,275,898 B1 8/2001 Dekoning
6,347,337 B1 2/2002 Shah et al.
6,363,385 B1 3/2002 Kedem et al.
6,385,699 B1 5/2002 Bozman et al.
6,397,307 B2 5/2002 Ohran
6,434,555 B1 8/2002 Frolund et al.
6,434,662 B1 8/2002 Greene et al.
6,526,478 B1 2/2003 Kirby
6,553,384 B1 4/2003 Frey et al.
6,560,196 B1 5/2003 Wei
6,567,817 B1 5/2003 Vanleer et al.
6,578,158 B1 6/2003 Deitz et al.
6,604,155 B1 8/2003 Chong, Jr.
6,609,176 B1 8/2003 Mizuno
6,640,312 B1 10/2003 Thomson et al.
6,681,389 B1 1/2004 Engel et al.
6,704,839 B2 3/2004 Butterworth et al.
6,728,843 B1 4/2004 Pong et al.
6,741,698 B1 5/2004 Jensen
6,779,003 B1 8/2004 Midgley et al.
6,795,890 B1 9/2004 Sugai et al.
6,895,500 B1 5/2005 Rothberg
6,904,470 B1 6/2005 Ofer et al.
6,912,645 B2 6/2005 Dorward et al.
6,917,898 B1 7/2005 Kirubalaratnam et al.
6,928,521 B1 8/2005 Burton et al.

6,928,526 B1 8/2005 Zhu et al.
6,961,865 B1 11/2005 Ganesh et al.
7,003,565 B2 2/2006 Hind et al.
7,028,218 B2 4/2006 Schwarm et al.
7,039,694 B2 5/2006 Kampe et al.
7,047,358 B2 5/2006 Lee et al.
7,055,058 B2 5/2006 Lee et al.
7,065,619 B1 6/2006 Zhu et al.
7,093,086 B1 8/2006 Van Rietschote
7,110,913 B2 9/2006 Monroe et al.
7,152,142 B1 12/2006 Guha et al.
7,167,951 B2 1/2007 Blades et al.
7,174,379 B2 2/2007 Agarwal et al.
7,177,853 B1 2/2007 Ezra et al.
7,188,149 B2 3/2007 Kishimoto et al.
7,191,357 B2 3/2007 Holland et al.
7,219,260 B1 5/2007 De Forest et al.
7,249,150 B1 7/2007 Watanabe et al.
7,251,663 B1 7/2007 Smith
7,257,690 B1 8/2007 Baird
7,305,579 B2 12/2007 Williams
7,325,059 B2 1/2008 Barach et al.
7,334,094 B2 2/2008 Fair
7,334,095 B1 2/2008 Fair et al.
7,366,865 B2 4/2008 Lakshmanamurthy et al.
7,370,048 B2 5/2008 Loeb
7,373,345 B2 5/2008 Carpentier et al.
7,394,944 B2 7/2008 Boskovic et al.
7,395,283 B1 7/2008 Atzmony et al.
7,395,352 B1 7/2008 Lam et al.
7,415,653 B1 8/2008 Bonwick et al.
7,451,167 B2 11/2008 Bali et al.
7,454,592 B1 11/2008 Shah et al.
7,457,864 B2 11/2008 Chambliss et al.
7,464,125 B1 12/2008 Orszag et al.
7,519,725 B2 4/2009 Alvarez et al.
7,526,685 B2 4/2009 Maso et al.
7,529,780 B1 5/2009 Braginsky et al.
7,529,830 B2 5/2009 Fujii
7,543,100 B2 6/2009 Singhal et al.
7,543,178 B2 6/2009 McNeill et al.
7,562,101 B1 7/2009 Jernigan, IV et al.
7,562,203 B2 7/2009 Scott et al.
7,603,391 B1 10/2009 Federwisch et al.
7,603,529 B1 10/2009 Machardy et al.
7,624,112 B2 11/2009 Ganesh et al.
7,644,087 B2 1/2010 Barkai et al.
7,650,476 B2 1/2010 Ashour et al.
7,668,885 B2 2/2010 Wittke et al.
7,680,837 B2 3/2010 Yamato
7,681,076 B1 3/2010 Sarma
7,689,716 B2 3/2010 Short et al.
7,701,948 B2 4/2010 Rabje et al.
7,730,153 B1 6/2010 Gole et al.
7,739,614 B1 6/2010 Hackworth
7,743,035 B2 6/2010 Chen et al.
7,757,056 B1 7/2010 Fair
7,797,279 B1 9/2010 Starling et al.
7,805,266 B1 9/2010 Dasu et al.
7,805,583 B1 9/2010 Todd et al.
7,814,064 B2 10/2010 Vingralek
7,817,562 B1 10/2010 Kemeny
7,818,525 B1 10/2010 Frost et al.
7,831,736 B1 11/2010 Thompson
7,831,769 B1 11/2010 Wen et al.
7,849,098 B1 12/2010 Scales et al.
7,849,281 B2 12/2010 Malhotra et al.
7,873,619 B1 1/2011 Faibish et al.
7,899,791 B1 3/2011 Gole
7,917,726 B2 3/2011 Hummel et al.
7,921,169 B2 4/2011 Jacobs et al.
7,921,325 B2 4/2011 Kondo et al.
7,949,693 B1 5/2011 Mason et al.
7,953,878 B1 5/2011 Trimble
7,962,709 B2 6/2011 Agrawal
7,987,167 B1 7/2011 Kazar et al.
7,996,636 B1 8/2011 Prakash et al.
8,055,745 B2 11/2011 Atluri
8,060,797 B2 11/2011 Hida et al.

(56)

References Cited

U.S. PATENT DOCUMENTS

8,074,019 B2	12/2011	Gupta et al.	8,799,601 B1	8/2014	Chen et al.
8,078,918 B2	12/2011	Diggs et al.	8,799,705 B2	8/2014	Hallak et al.
8,082,390 B1	12/2011	Fan et al.	8,806,115 B1	8/2014	Patel et al.
8,086,585 B1	12/2011	Brashers et al.	8,806,160 B2	8/2014	Colgrove et al.
8,089,969 B2	1/2012	Rabie et al.	8,812,450 B1	8/2014	Kesavan et al.
8,090,908 B1	1/2012	Bolen et al.	8,819,208 B2	8/2014	Wright
8,099,396 B1	1/2012	Novick et al.	8,824,686 B1	9/2014	Ishii et al.
8,099,554 B1	1/2012	Solomon et al.	8,826,023 B1	9/2014	Harmer et al.
8,122,213 B2	2/2012	Cherian et al.	8,832,363 B1	9/2014	Sundaram et al.
8,127,182 B2	2/2012	Sivaperuman et al.	8,832,373 B2	9/2014	Colgrove et al.
8,131,926 B2	3/2012	Lubbers et al.	8,843,711 B1	9/2014	Yadav et al.
8,140,821 B1	3/2012	Raizen et al.	8,849,764 B1	9/2014	Long et al.
8,140,860 B2	3/2012	Haswell	8,850,108 B1	9/2014	Hayes et al.
8,145,838 B1	3/2012	Miller et al.	8,850,216 B1	9/2014	Mikhailov et al.
8,156,016 B2	4/2012	Zhang	8,855,318 B1	10/2014	Patnala et al.
8,156,290 B1	4/2012	Vanninen et al.	8,856,593 B2	10/2014	Eckhardt et al.
8,156,306 B1	4/2012	Raizen et al.	8,868,868 B1	10/2014	Maheshwari et al.
8,184,807 B2	5/2012	Kato et al.	8,874,842 B1	10/2014	Kimmel et al.
8,205,065 B2	6/2012	Matze	8,880,787 B1	11/2014	Kimmel et al.
8,209,587 B1	6/2012	Taylor et al.	8,880,788 B1	11/2014	Sundaram et al.
8,214,868 B2	7/2012	Hamilton et al.	8,892,818 B1	11/2014	Zheng et al.
8,224,935 B1	7/2012	Bandopadhyay et al.	8,892,938 B1	11/2014	Sundaram et al.
8,225,135 B2	7/2012	Barrall et al.	8,898,388 B1	11/2014	Kimmel
8,244,978 B2	8/2012	Kegel et al.	8,904,137 B1	12/2014	Zhang et al.
8,250,116 B2	8/2012	Mazzagatti et al.	8,904,231 B2	12/2014	Coatney et al.
8,261,085 B1	9/2012	Fernandez	8,922,928 B2	12/2014	Powell
8,312,231 B1	11/2012	Li et al.	8,930,778 B2	1/2015	Cohen
8,327,103 B1	12/2012	Can et al.	8,943,032 B1	1/2015	Xu et al.
8,332,357 B1	12/2012	Chung	8,943,282 B1	1/2015	Armangau et al.
8,341,457 B2	12/2012	Spry et al.	8,949,568 B2	2/2015	Wei et al.
8,369,217 B2	2/2013	Bostica et al.	8,977,781 B1	3/2015	Yokoi et al.
8,417,987 B1	4/2013	Goel et al.	8,996,468 B1	3/2015	Mattox
8,429,096 B1	4/2013	Soundararajan et al.	8,996,535 B1	3/2015	Kimmel et al.
8,429,282 B1	4/2013	Ahuja et al.	8,996,790 B1	3/2015	Segal et al.
8,452,929 B2	5/2013	Bennett	8,996,797 B1	3/2015	Zheng et al.
8,463,825 B1	6/2013	Harty et al.	9,003,162 B2	4/2015	Lomet et al.
8,468,368 B2	6/2013	Gladwin et al.	9,009,449 B2	4/2015	Chou et al.
8,484,439 B1	7/2013	Frailong et al.	9,021,303 B1	4/2015	Desouter et al.
8,489,811 B1	7/2013	Corbett et al.	9,026,694 B1	5/2015	Davidson et al.
8,495,417 B2	7/2013	Jernigan, IV et al.	9,037,544 B1	5/2015	Zheng et al.
8,510,265 B1	8/2013	Boone et al.	9,047,211 B2	6/2015	Wood et al.
8,515,965 B2	8/2013	Mital et al.	9,058,119 B1	6/2015	Ray, III et al.
8,520,855 B1	8/2013	Kohno et al.	9,092,142 B2	7/2015	Nashimoto et al.
8,533,410 B1	9/2013	Corbett et al.	9,152,330 B2	10/2015	Patel et al.
8,539,008 B2	9/2013	Faith et al.	9,152,335 B2	10/2015	Sundaram et al.
8,543,611 B1	9/2013	Mirtich et al.	9,152,684 B2	10/2015	Zheng et al.
8,549,154 B2	10/2013	Colrain et al.	9,170,746 B2	10/2015	Sundaram et al.
8,555,019 B2	10/2013	Montgomery et al.	9,195,939 B1	11/2015	Goyal et al.
8,560,879 B1	10/2013	Goel	9,201,742 B2	12/2015	Bulkowski et al.
8,566,508 B2	10/2013	Borchers et al.	9,201,804 B1	12/2015	Egyed
8,566,617 B1	10/2013	Clifford	9,201,918 B2	12/2015	Zheng et al.
8,572,091 B1	10/2013	Sivasubramanian et al.	9,225,801 B1	12/2015	McMullen et al.
8,577,850 B1	11/2013	Genda et al.	9,229,642 B2	1/2016	Shu et al.
8,583,865 B1	11/2013	Sade et al.	9,251,064 B2	2/2016	Kimmel
8,589,550 B1	11/2013	Faibish et al.	9,256,549 B2	2/2016	Kimmel et al.
8,589,625 B2	11/2013	Colgrove et al.	9,268,502 B2	2/2016	Zheng et al.
8,595,434 B2	11/2013	Northcutt et al.	9,268,653 B2	2/2016	Kimmel et al.
8,595,595 B1	11/2013	Grcanac et al.	9,274,901 B2	3/2016	Veerla et al.
8,600,949 B2	12/2013	Periyagaram et al.	9,286,413 B1	3/2016	Coates et al.
8,626,875 B2 *	1/2014	Viveganandhan H04L 65/613 709/224	9,298,417 B1	3/2016	Muddu et al.
8,645,664 B1	2/2014	Colgrove et al.	9,323,701 B2	4/2016	Shankar
8,645,698 B2	2/2014	Yi et al.	9,342,444 B2	5/2016	Minckler et al.
8,671,265 B2	3/2014	Wright	9,348,514 B2	5/2016	Fornander et al.
8,706,692 B1	4/2014	Luthra et al.	9,367,241 B2	6/2016	Sundaram et al.
8,706,701 B1	4/2014	Stefanov et al.	9,372,789 B2	6/2016	Minckler et al.
8,712,963 B1	4/2014	Douglis et al.	9,377,953 B2	6/2016	Fornander et al.
8,732,426 B2	5/2014	Colgrove et al.	9,378,043 B1	6/2016	Zhang et al.
8,745,338 B1	6/2014	Yadav et al.	9,383,933 B2	7/2016	Wright
8,751,763 B1	6/2014	Ramarao	9,389,958 B2	7/2016	Sundaram et al.
8,762,654 B1	6/2014	Yang et al.	9,400,609 B1	7/2016	Randall et al.
8,775,868 B2	7/2014	Colgrove et al.	9,405,473 B2	8/2016	Zheng et al.
8,782,439 B2	7/2014	Resch	9,405,783 B2	8/2016	Kimmel et al.
8,787,580 B2	7/2014	Hodges et al.	9,411,620 B2	8/2016	Wang et al.
8,799,571 B1	8/2014	Desroches et al.	9,413,680 B1	8/2016	Kusters et al.
			9,418,131 B1	8/2016	Halevi et al.
			9,423,964 B1	8/2016	Randall et al.
			9,438,665 B1	9/2016	Vasanth et al.
			9,454,434 B2	9/2016	Sundaram et al.
			9,459,856 B2	10/2016	Curzi et al.

(56)

References Cited

U.S. PATENT DOCUMENTS							
9,460,009	B1	10/2016	Taylor et al.	2002/0091897	A1	7/2002	Chiu et al.
9,471,248	B2	10/2016	Zheng et al.	2002/0116569	A1	8/2002	Kim et al.
9,471,680	B2	10/2016	Elsner et al.	2002/0156891	A1	10/2002	Ulrich et al.
9,483,349	B2	11/2016	Sundaram et al.	2002/0158898	A1	10/2002	Hsieh et al.
9,507,537	B2	11/2016	Wright	2002/0174419	A1	11/2002	Alvarez et al.
9,529,546	B2	12/2016	Sundaram et al.	2002/0175938	A1	11/2002	Hackworth
9,537,827	B1	1/2017	McMullen et al.	2002/0188711	A1	12/2002	Meyer et al.
9,563,654	B2	2/2017	Zheng et al.	2003/0005147	A1	1/2003	Enns et al.
9,572,091	B2	2/2017	Lee et al.	2003/0084251	A1	5/2003	Gaither et al.
9,606,874	B2	3/2017	Moore et al.	2003/0105928	A1	6/2003	Ash et al.
9,613,046	B1	4/2017	Xu et al.	2003/0115204	A1	6/2003	Greenblatt et al.
9,619,160	B2	4/2017	Patel et al.	2003/0115282	A1	6/2003	Rose
9,619,351	B2	4/2017	Sundaram et al.	2003/0120869	A1	6/2003	Lee et al.
9,639,278	B2	5/2017	Kimmel et al.	2003/0126118	A1	7/2003	Burton et al.
9,639,293	B2	5/2017	Guo et al.	2003/0126143	A1	7/2003	Roussopoulos et al.
9,639,546	B1	5/2017	Gorski et al.	2003/0135729	A1	7/2003	Mason et al.
9,652,405	B1	5/2017	Shain et al.	2003/0145041	A1	7/2003	Dunham et al.
9,671,960	B2	6/2017	Patel et al.	2003/0159007	A1	8/2003	Sawdon et al.
9,690,703	B1	6/2017	Jess et al.	2003/0163628	A1	8/2003	Lin et al.
9,710,317	B2	7/2017	Gupta et al.	2003/0172059	A1	9/2003	Andrei
9,720,601	B2	8/2017	Gupta et al.	2003/0182312	A1	9/2003	Chen et al.
9,720,822	B2	8/2017	Kimmel	2003/0182322	A1	9/2003	Manley et al.
9,762,460	B2	9/2017	Pawlowski et al.	2003/0191916	A1	10/2003	McBrearty et al.
9,779,123	B2	10/2017	Sen et al.	2003/0195895	A1	10/2003	Nowicki et al.
9,785,525	B2	10/2017	Watanabe et al.	2003/0200388	A1	10/2003	Hetrick
9,798,497	B1	10/2017	Schick et al.	2003/0212872	A1	11/2003	Patterson et al.
9,798,728	B2	10/2017	Zheng	2003/0223445	A1	12/2003	Lodha
9,817,858	B2	11/2017	Eisenreich et al.	2004/0003173	A1	1/2004	Yao et al.
9,823,857	B1 *	11/2017	Pendharkar G06F 3/0613	2004/0052254	A1	3/2004	Hooper
9,830,103	B2	11/2017	Pundir et al.	2004/0054656	A1	3/2004	Leung et al.
9,836,355	B2	12/2017	Pundir et al.	2004/0107281	A1	6/2004	Bose et al.
9,836,366	B2	12/2017	Schatz et al.	2004/0133590	A1	7/2004	Henderson et al.
9,842,008	B2	12/2017	Kimmel et al.	2004/0133622	A1	7/2004	Clubb et al.
9,846,642	B2	12/2017	Choi et al.	2004/0133742	A1	7/2004	Vasudevan et al.
9,852,076	B1	12/2017	Garg et al.	2004/0153544	A1	8/2004	Kelliher et al.
9,934,264	B2	4/2018	Swaminathan et al.	2004/0153863	A1	8/2004	Klotz et al.
9,952,767	B2	4/2018	Zheng et al.	2004/0158549	A1	8/2004	Matena et al.
9,953,351	B1	4/2018	Sivasubramanian et al.	2004/0186858	A1	9/2004	McGovern et al.
9,954,946	B2	4/2018	Shetty	2004/0205166	A1	10/2004	Demoney
10,013,311	B2	7/2018	Sundaram et al.	2004/0210794	A1	10/2004	Frey et al.
10,037,146	B2	7/2018	Wright	2004/0215792	A1	10/2004	Koning et al.
10,042,853	B2	8/2018	Sundaram et al.	2004/0267836	A1	12/2004	Armangau et al.
10,049,118	B2	8/2018	Patel et al.	2004/0267932	A1	12/2004	Voellm et al.
10,108,547	B2	10/2018	Pundir et al.	2005/0010653	A1	1/2005	McCanne
10,133,511	B2	11/2018	Muth et al.	2005/0027817	A1	2/2005	Novik et al.
10,162,686	B2	12/2018	Kimmel et al.	2005/0039156	A1	2/2005	Catthoor et al.
10,185,681	B2	1/2019	Kimmel	2005/0043834	A1	2/2005	Rotariu et al.
10,210,082	B2	2/2019	Patel et al.	2005/0044244	A1	2/2005	Warwick et al.
10,216,966	B2	2/2019	McClanahan et al.	2005/0076113	A1	4/2005	Klotz et al.
10,229,009	B2	3/2019	Muth et al.	2005/0076115	A1	4/2005	Andrews et al.
10,235,059	B2	3/2019	Patel et al.	2005/0080923	A1	4/2005	Elzur
10,339,132	B2	7/2019	Zaveri et al.	2005/0091261	A1	4/2005	Wu et al.
10,360,120	B2	7/2019	Watanabe et al.	2005/0108472	A1	5/2005	Kanai et al.
10,365,838	B2	7/2019	D'Sa et al.	2005/0119996	A1	6/2005	Ohata et al.
10,439,900	B2	10/2019	Wright et al.	2005/0128951	A1	6/2005	Chawla et al.
10,452,608	B2	10/2019	Cantwell et al.	2005/0138285	A1	6/2005	Takaoka et al.
10,460,124	B2	10/2019	Wright et al.	2005/0144514	A1	6/2005	Ulrich et al.
10,516,582	B2	12/2019	Wright et al.	2005/0177770	A1	8/2005	Coatney et al.
10,530,880	B2	1/2020	McMullen et al.	2005/0203930	A1	9/2005	Bukowski et al.
10,565,230	B2	2/2020	Zheng et al.	2005/0216503	A1	9/2005	Charlot et al.
10,642,763	B2	5/2020	Longo et al.	2005/0228885	A1	10/2005	Winfield et al.
10,664,366	B2	5/2020	Schatz et al.	2005/0246362	A1	11/2005	Borland
10,712,944	B2	7/2020	Wright	2005/0246398	A1	11/2005	Barzilai et al.
10,762,070	B2	9/2020	Swaminathan et al.	2006/0004957	A1	1/2006	Hand et al.
10,789,134	B2	9/2020	Zheng et al.	2006/0071845	A1	4/2006	Stroili et al.
10,911,328	B2	2/2021	Wright et al.	2006/0072555	A1	4/2006	St. Hilaire et al.
10,929,022	B2	2/2021	Goel et al.	2006/0072593	A1	4/2006	Grippio et al.
10,951,488	B2	3/2021	Wright et al.	2006/0074977	A1	4/2006	Kothuri et al.
10,997,098	B2	5/2021	Longo et al.	2006/0075467	A1	4/2006	Sanda et al.
11,212,196	B2	12/2021	Wright et al.	2006/0085166	A1	4/2006	Ochi et al.
11,327,910	B2	5/2022	Longo et al.	2006/0101091	A1	5/2006	Carbajales et al.
11,379,119	B2	7/2022	Wright	2006/0101202	A1	5/2006	Mannen et al.
11,386,120	B2	7/2022	Cantwell et al.	2006/0112155	A1	5/2006	Earl et al.
2001/0056543	A1	12/2001	Isomura et al.	2006/0129676	A1	6/2006	Modi et al.
2002/0073354	A1	6/2002	Schroiff et al.	2006/0136718	A1	6/2006	Moreillon
				2006/0156059	A1	7/2006	Kitamura
				2006/0165074	A1	7/2006	Modi et al.
				2006/0206671	A1	9/2006	Aiello et al.
				2006/0232826	A1	10/2006	Bar-El

(56)

References Cited

U.S. PATENT DOCUMENTS

2006/0253749	A1	11/2006	Alderegula et al.	2010/0011037	A1	1/2010	Kazar
2006/0282662	A1	12/2006	Whitcomb	2010/0023726	A1	1/2010	Aviles
2006/0288151	A1	12/2006	McKenney	2010/0030981	A1	2/2010	Cook
2007/0016617	A1	1/2007	Lomet	2010/0031000	A1	2/2010	Flynn et al.
2007/0033376	A1	2/2007	Sinclair et al.	2010/0031315	A1	2/2010	Feng et al.
2007/0033433	A1	2/2007	Pecone et al.	2010/0042790	A1	2/2010	Mondal et al.
2007/0061572	A1	3/2007	Imai et al.	2010/0057792	A1	3/2010	Ylonen
2007/0064604	A1	3/2007	Chen et al.	2010/0070701	A1	3/2010	Iyigun et al.
2007/0083482	A1	4/2007	Rathi et al.	2010/0077101	A1	3/2010	Wang et al.
2007/0083722	A1	4/2007	Per et al.	2010/0077380	A1	3/2010	Baker et al.
2007/0088702	A1	4/2007	Fridella et al.	2010/0082648	A1	4/2010	Potapov et al.
2007/0094452	A1	4/2007	Fachan	2010/0082790	A1	4/2010	Hussaini et al.
2007/0106706	A1	5/2007	Ahrens et al.	2010/0122148	A1	5/2010	Flynn et al.
2007/0109592	A1	5/2007	Parvathaneni et al.	2010/0124196	A1	5/2010	Bonar et al.
2007/0112723	A1	5/2007	Alvarez et al.	2010/0161569	A1	6/2010	Schreter
2007/0112955	A1	5/2007	Clemm et al.	2010/0161574	A1	6/2010	Davidson et al.
2007/0136269	A1	6/2007	Yamakabe et al.	2010/0161850	A1	6/2010	Otsuka
2007/0143359	A1	6/2007	Uppala et al.	2010/0169415	A1	7/2010	Leggette et al.
2007/0186066	A1	8/2007	Desai et al.	2010/0174677	A1	7/2010	Zahavi et al.
2007/0186127	A1	8/2007	Desai et al.	2010/0174714	A1	7/2010	Asmundsson et al.
2007/0208537	A1	9/2007	Savoor et al.	2010/0191713	A1	7/2010	Lomet et al.
2007/0208918	A1	9/2007	Harbin et al.	2010/0199009	A1	8/2010	Koide
2007/0234106	A1	10/2007	Lecrone et al.	2010/0199040	A1	8/2010	Schnapp et al.
2007/0245041	A1	10/2007	Hua et al.	2010/0205353	A1	8/2010	Miyamoto et al.
2007/0255530	A1	11/2007	Wolff	2010/0205390	A1	8/2010	Arakawa
2007/0266037	A1	11/2007	Terry et al.	2010/0217953	A1	8/2010	Beaman et al.
2007/0300013	A1	12/2007	Kitamura	2010/0223385	A1	9/2010	Gulley et al.
2008/0019359	A1	1/2008	Droux et al.	2010/0228795	A1	9/2010	Hahn et al.
2008/0065639	A1	3/2008	Choudhary et al.	2010/0228999	A1	9/2010	Maheshwari et al.
2008/0071939	A1	3/2008	Tanaka et al.	2010/0250497	A1	9/2010	Redlich et al.
2008/0104264	A1	5/2008	Duerk et al.	2010/0250712	A1	9/2010	Ellison et al.
2008/0126695	A1	5/2008	Berg	2010/0262812	A1	10/2010	Lopez et al.
2008/0127211	A1	5/2008	Belsey et al.	2010/0268983	A1	10/2010	Raghuandan
2008/0155190	A1	6/2008	Ash et al.	2010/0269044	A1	10/2010	Ivanyi et al.
2008/0162079	A1	7/2008	Astigarraga et al.	2010/0280998	A1	11/2010	Goebel et al.
2008/0162990	A1	7/2008	Wang et al.	2010/0281080	A1	11/2010	Rajaram et al.
2008/0165899	A1	7/2008	Rahman et al.	2010/0293147	A1	11/2010	Snow et al.
2008/0168226	A1	7/2008	Wang et al.	2010/0306468	A1	12/2010	Shionoya
2008/0184063	A1	7/2008	Abdulvahid	2010/0309933	A1	12/2010	Stark et al.
2008/0201535	A1	8/2008	Hara	2011/0004707	A1	1/2011	Spry et al.
2008/0212938	A1	9/2008	Sato et al.	2011/0022778	A1	1/2011	Schibilla et al.
2008/0228691	A1	9/2008	Shavit et al.	2011/0035548	A1	2/2011	Kimmel et al.
2008/0244158	A1	10/2008	Funatsu et al.	2011/0066808	A1	3/2011	Flynn et al.
2008/0244354	A1	10/2008	Wu et al.	2011/0072008	A1	3/2011	Mandal et al.
2008/0250270	A1	10/2008	Bennett	2011/0078496	A1	3/2011	Jeddeloh
2008/0270719	A1	10/2008	Cochran et al.	2011/0087929	A1	4/2011	Koshiyama
2009/0019449	A1	1/2009	Choi et al.	2011/0093674	A1	4/2011	Frame et al.
2009/0031083	A1	1/2009	Willis et al.	2011/0099342	A1	4/2011	Ozdemir et al.
2009/0037500	A1	2/2009	Kirshenbaum	2011/0099419	A1	4/2011	Lucas et al.
2009/0037654	A1	2/2009	Allison et al.	2011/0119412	A1	5/2011	Orfitelli
2009/0043878	A1	2/2009	Ni	2011/0119668	A1	5/2011	Calder et al.
2009/0083478	A1	3/2009	Kunimatsu et al.	2011/0126045	A1	5/2011	Bennett et al.
2009/0097654	A1	4/2009	Blake	2011/0153603	A1	6/2011	Adiba et al.
2009/0132770	A1	5/2009	Lin et al.	2011/0153719	A1	6/2011	Santoro et al.
2009/0144497	A1	6/2009	Withers	2011/0153972	A1	6/2011	Laberge
2009/0150537	A1	6/2009	Fanson	2011/0154103	A1	6/2011	Bulusu et al.
2009/0157870	A1	6/2009	Nakadai	2011/0161293	A1	6/2011	Vermeulen et al.
2009/0193206	A1	7/2009	Ishii et al.	2011/0161725	A1	6/2011	Allen et al.
2009/0204636	A1	8/2009	Li et al.	2011/0173401	A1	7/2011	Usgaonkar et al.
2009/0210611	A1	8/2009	Mizushima	2011/0191389	A1	8/2011	Okamoto
2009/0210618	A1	8/2009	Bates et al.	2011/0191522	A1	8/2011	Condict et al.
2009/0225657	A1	9/2009	Haggar et al.	2011/0196842	A1	8/2011	Timashev et al.
2009/0235022	A1	9/2009	Bates et al.	2011/0202516	A1	8/2011	Rugg et al.
2009/0235110	A1	9/2009	Kurokawa et al.	2011/0213928	A1	9/2011	Grube et al.
2009/0249001	A1	10/2009	Narayanan et al.	2011/0231624	A1	9/2011	Fukutomi et al.
2009/0249019	A1	10/2009	Wu et al.	2011/0238546	A1*	9/2011	Certain G06Q 30/04 705/418
2009/0271412	A1	10/2009	Lacapra et al.	2011/0238857	A1	9/2011	Certain et al.
2009/0276567	A1	11/2009	Burkey	2011/0246733	A1	10/2011	Usgaonkar et al.
2009/0276771	A1	11/2009	Nickolov et al.	2011/0246821	A1	10/2011	Eleftheriou et al.
2009/0285476	A1	11/2009	Choe et al.	2011/0283048	A1	11/2011	Feldman et al.
2009/0299940	A1	12/2009	Hayes et al.	2011/0286123	A1	11/2011	Montgomery et al.
2009/0307290	A1	12/2009	Barsness et al.	2011/0289565	A1	11/2011	Resch et al.
2009/0313451	A1	12/2009	Inoue et al.	2011/0296133	A1	12/2011	Flynn et al.
2009/0313503	A1	12/2009	Atluri et al.	2011/0302572	A1	12/2011	Kuncoro et al.
2009/0327604	A1	12/2009	Sato et al.	2011/0307530	A1	12/2011	Patterson
				2011/0311051	A1	12/2011	Resch et al.
				2011/0314346	A1	12/2011	Vas et al.
				2012/0003940	A1	1/2012	Hirano et al.

(56)

References Cited

U.S. PATENT DOCUMENTS

2012/0011176	A1	1/2012	Aizman	2013/0138862	A1	5/2013	Motwani et al.
2012/0011340	A1	1/2012	Flynn et al.	2013/0148504	A1	6/2013	Ungureanu
2012/0016840	A1	1/2012	Lin et al.	2013/0159512	A1	6/2013	Groves et al.
2012/0047115	A1	2/2012	Subramanya et al.	2013/0159815	A1	6/2013	Jung et al.
2012/0054746	A1	3/2012	Vaghani et al.	2013/0166724	A1	6/2013	Bairavasundaram et al.
2012/0063306	A1	3/2012	Sultan et al.	2013/0166727	A1	6/2013	Wright et al.
2012/0066204	A1	3/2012	Ball et al.	2013/0166861	A1	6/2013	Takano et al.
2012/0072656	A1	3/2012	Archak et al.	2013/0185403	A1	7/2013	Vachharajani et al.
2012/0072680	A1	3/2012	Kimura et al.	2013/0185719	A1	7/2013	Kar et al.
2012/0078856	A1	3/2012	Linde	2013/0198480	A1	8/2013	Jones et al.
2012/0084506	A1	4/2012	Colgrove et al.	2013/0204902	A1	8/2013	Wang et al.
2012/0109895	A1	5/2012	Zwilling et al.	2013/0219048	A1	8/2013	Arvidsson et al.
2012/0109936	A1	5/2012	Zhang et al.	2013/0219214	A1	8/2013	Samanta et al.
2012/0124282	A1	5/2012	Frank et al.	2013/0226877	A1	8/2013	Nagai et al.
2012/0136834	A1	5/2012	Zhao	2013/0227111	A1	8/2013	Wright et al.
2012/0143877	A1	6/2012	Kumar et al.	2013/0227145	A1	8/2013	Wright et al.
2012/0150869	A1	6/2012	Wang et al.	2013/0227195	A1	8/2013	Beaverson et al.
2012/0150930	A1	6/2012	Jin et al.	2013/0227201	A1	8/2013	Talagala et al.
2012/0151118	A1	6/2012	Flynn et al.	2013/0227236	A1	8/2013	Flynn et al.
2012/0166715	A1	6/2012	Frost et al.	2013/0232240	A1	9/2013	Purusothaman et al.
2012/0166749	A1	6/2012	Eleftheriou et al.	2013/0232261	A1	9/2013	Wright et al.
2012/0185437	A1	7/2012	Pavlov et al.	2013/0238832	A1	9/2013	Dronamraju et al.
2012/0197844	A1	8/2012	Wang et al.	2013/0238876	A1	9/2013	Fiske et al.
2012/0210095	A1	8/2012	Nellans et al.	2013/0238932	A1	9/2013	Resch
2012/0226668	A1	9/2012	Dhamankar et al.	2013/0262404	A1	10/2013	Daga et al.
2012/0226841	A1	9/2012	Nguyen et al.	2013/0262412	A1	10/2013	Hawton et al.
2012/0239869	A1	9/2012	Chiueh et al.	2013/0262746	A1	10/2013	Srinivasan
2012/0240126	A1	9/2012	Dice et al.	2013/0262762	A1	10/2013	Igashira et al.
2012/0243687	A1	9/2012	Li et al.	2013/0262805	A1	10/2013	Zheng et al.
2012/0246129	A1	9/2012	Rothschild et al.	2013/0268497	A1	10/2013	Baldwin et al.
2012/0246392	A1	9/2012	Cheon	2013/0275656	A1	10/2013	Talagala et al.
2012/0271868	A1	10/2012	Fukatani et al.	2013/0290249	A1	10/2013	Merriman et al.
2012/0290629	A1	11/2012	Beaverson et al.	2013/0290263	A1	10/2013	Beaverson et al.
2012/0290788	A1	11/2012	Klemm et al.	2013/0298170	A1	11/2013	Elarabawy et al.
2012/0303876	A1	11/2012	Benhase et al.	2013/0304998	A1	11/2013	Palmer et al.
2012/0310890	A1	12/2012	Dodd et al.	2013/0305002	A1	11/2013	Hallak et al.
2012/0311246	A1	12/2012	McWilliams et al.	2013/0311740	A1	11/2013	Watanabe et al.
2012/0311290	A1	12/2012	White	2013/0325828	A1	12/2013	Larson et al.
2012/0311292	A1	12/2012	Maniwa et al.	2013/0326546	A1	12/2013	Bavishi et al.
2012/0311568	A1	12/2012	Jansen	2013/0339629	A1	12/2013	Alexander et al.
2012/0317084	A1	12/2012	Liu	2013/0346700	A1	12/2013	Tomlinson et al.
2012/0317338	A1	12/2012	Yi et al.	2013/0346720	A1	12/2013	Colgrove et al.
2012/0317353	A1	12/2012	Webman et al.	2013/0346810	A1	12/2013	Kimmel et al.
2012/0317395	A1	12/2012	Segev et al.	2014/0006353	A1	1/2014	Chen et al.
2012/0323860	A1	12/2012	Yasa et al.	2014/0013068	A1	1/2014	Yamato et al.
2012/0324150	A1	12/2012	Moshayedi et al.	2014/0025986	A1	1/2014	Kalyanaraman et al.
2012/0331471	A1	12/2012	Ramalingam et al.	2014/0052764	A1	2/2014	Michael et al.
2013/0007097	A1	1/2013	Sambe et al.	2014/0059309	A1	2/2014	Brown et al.
2013/0007370	A1	1/2013	Parikh et al.	2014/0068184	A1	3/2014	Edwards et al.
2013/0010966	A1	1/2013	Li et al.	2014/0081906	A1	3/2014	Geddam et al.
2013/0013654	A1	1/2013	Lacapra et al.	2014/0081918	A1	3/2014	Srivastava et al.
2013/0018722	A1	1/2013	Libby	2014/0082255	A1	3/2014	Powell
2013/0018854	A1	1/2013	Condict	2014/0082273	A1	3/2014	Segev
2013/0019057	A1	1/2013	Stephens et al.	2014/0089264	A1	3/2014	Talagala et al.
2013/0024641	A1*	1/2013	Talagala G06F 11/3442 711/170	2014/0089683	A1	3/2014	Miller et al.
2013/0042065	A1	2/2013	Kasten et al.	2014/0095758	A1	4/2014	Smith et al.
2013/0054927	A1	2/2013	Raj et al.	2014/0095803	A1	4/2014	Kim et al.
2013/0055358	A1	2/2013	Short et al.	2014/0101115	A1	4/2014	Ko et al.
2013/0060992	A1	3/2013	Cho et al.	2014/0101298	A1	4/2014	Shukla et al.
2013/0061169	A1	3/2013	Pearcy et al.	2014/0108350	A1	4/2014	Marsden
2013/0073519	A1	3/2013	Lewis et al.	2014/0108797	A1	4/2014	Johnson et al.
2013/0073821	A1	3/2013	Flynn et al.	2014/0108863	A1	4/2014	Nowoczynski et al.
2013/0080679	A1	3/2013	Bert	2014/0129830	A1	5/2014	Raudaschl
2013/0080720	A1	3/2013	Nakamura et al.	2014/0143207	A1	5/2014	Brewer et al.
2013/0083639	A1	4/2013	Wharton et al.	2014/0143213	A1	5/2014	Tal et al.
2013/0086006	A1	4/2013	Colgrove et al.	2014/0149355	A1	5/2014	Gupta et al.
2013/0086270	A1	4/2013	Nishikawa et al.	2014/0149647	A1	5/2014	Guo et al.
2013/0086336	A1	4/2013	Canepa et al.	2014/0164715	A1	6/2014	Weiner et al.
2013/0097341	A1	4/2013	Oe et al.	2014/0172811	A1	6/2014	Green
2013/0110783	A1	5/2013	Wertheimer et al.	2014/0181370	A1	6/2014	Cohen et al.
2013/0110845	A1	5/2013	Dua	2014/0185615	A1	7/2014	Ayoub et al.
2013/0111374	A1	5/2013	Hamilton et al.	2014/0195199	A1	7/2014	Uluyol
2013/0124776	A1	5/2013	Hallak et al.	2014/0195480	A1	7/2014	Talagala et al.
2013/0138616	A1	5/2013	Gupta et al.	2014/0195492	A1	7/2014	Wilding et al.
				2014/0195564	A1	7/2014	Talagala et al.
				2014/0208003	A1	7/2014	Cohen et al.
				2014/0215129	A1	7/2014	Kuzmin et al.
				2014/0215147	A1	7/2014	Pan
				2014/0215170	A1	7/2014	Scarpino et al.

(56)

References Cited

U.S. PATENT DOCUMENTS

2014/0215262 A1 7/2014 Li et al.
 2014/0223029 A1 8/2014 Bhaskar et al.
 2014/0223089 A1 8/2014 Kang et al.
 2014/0244962 A1 8/2014 Arges et al.
 2014/0250440 A1 9/2014 Carter et al.
 2014/0258681 A1 9/2014 Prasky et al.
 2014/0259000 A1 9/2014 Desanti et al.
 2014/0279917 A1 9/2014 Minh et al.
 2014/0279931 A1 9/2014 Gupta et al.
 2014/0281017 A1 9/2014 Apte
 2014/0281055 A1 9/2014 Davda et al.
 2014/0281123 A1 9/2014 Weber
 2014/0281131 A1 9/2014 Joshi et al.
 2014/0283118 A1 9/2014 Anderson et al.
 2014/0289476 A1 9/2014 Nayak
 2014/0297980 A1 10/2014 Yamazaki
 2014/0304548 A1 10/2014 Steffan et al.
 2014/0310231 A1 10/2014 Sampathkumaran et al.
 2014/0310373 A1 10/2014 Aviles et al.
 2014/0317093 A1 10/2014 Sun et al.
 2014/0325117 A1 10/2014 Canepa et al.
 2014/0325147 A1 10/2014 Nayak
 2014/0331061 A1 11/2014 Wright et al.
 2014/0344216 A1 11/2014 Abercrombie et al.
 2014/0344222 A1 11/2014 Morris et al.
 2014/0344539 A1 11/2014 Gordon et al.
 2014/0372384 A1 12/2014 Long et al.
 2014/0379965 A1 12/2014 Gole et al.
 2014/0379990 A1 12/2014 Pan et al.
 2014/0379991 A1 12/2014 Lomet et al.
 2014/0380092 A1 12/2014 Kim et al.
 2015/0019792 A1 1/2015 Swanson et al.
 2015/0032928 A1 1/2015 Andrews et al.
 2015/0039716 A1 2/2015 Przykucki, Jr. et al.
 2015/0039745 A1 2/2015 Degioanni et al.
 2015/0039852 A1 2/2015 Sen et al.
 2015/0040052 A1 2/2015 Noel et al.
 2015/0052315 A1 2/2015 Ghai et al.
 2015/0058577 A1 2/2015 Earl
 2015/0066852 A1 3/2015 Beard et al.
 2015/0085665 A1 3/2015 Kompella et al.
 2015/0085695 A1 3/2015 Ryckbosch et al.
 2015/0089138 A1 3/2015 Tao et al.
 2015/0089285 A1 3/2015 Lim et al.
 2015/0095555 A1 4/2015 Asnaashari et al.
 2015/0106556 A1 4/2015 Yu et al.
 2015/0112939 A1 4/2015 Cantwell et al.
 2015/0120754 A1 4/2015 Chase et al.
 2015/0121021 A1 4/2015 Nakamura et al.
 2015/0127922 A1 5/2015 Camp et al.
 2015/0134926 A1 5/2015 Yang et al.
 2015/0169414 A1 6/2015 Lalsangi et al.
 2015/0172111 A1 6/2015 Lalsangi et al.
 2015/0186270 A1 7/2015 Peng et al.
 2015/0193338 A1 7/2015 Sundaram et al.
 2015/0199415 A1 7/2015 Bourbonnais et al.
 2015/0213032 A1 7/2015 Powell et al.
 2015/0220402 A1 8/2015 Cantwell et al.
 2015/0234709 A1 8/2015 Koarashi
 2015/0236926 A1 8/2015 Wright et al.
 2015/0242478 A1 8/2015 Cantwell et al.
 2015/0244795 A1 8/2015 Cantwell et al.
 2015/0253992 A1 9/2015 Ishiguro et al.
 2015/0254013 A1 9/2015 Chun
 2015/0261446 A1 9/2015 Lee
 2015/0261792 A1 9/2015 Attarde et al.
 2015/0269201 A1 9/2015 Caso et al.
 2015/0286438 A1 10/2015 Simionescu et al.
 2015/0288671 A1 10/2015 Chan et al.
 2015/0293817 A1 10/2015 Subramanian et al.
 2015/0301964 A1 10/2015 Brinicombe et al.
 2015/0324236 A1 11/2015 Gopalan et al.
 2015/0324264 A1 11/2015 Chinnakkonda et al.
 2015/0339194 A1 11/2015 Kalos et al.
 2015/0355985 A1 12/2015 Holtz et al.

2015/0363328 A1 12/2015 Candelaria
 2015/0370715 A1 12/2015 Samanta et al.
 2015/0378613 A1 12/2015 Koseki
 2016/0004733 A1 1/2016 Cao et al.
 2016/0011984 A1 1/2016 Speer et al.
 2016/0026552 A1 1/2016 Holden et al.
 2016/0034358 A1 2/2016 Hayasaka et al.
 2016/0034550 A1 2/2016 Ostler et al.
 2016/0048342 A1 2/2016 Jia et al.
 2016/0070480 A1 3/2016 Babu et al.
 2016/0070490 A1 3/2016 Koarashi et al.
 2016/0070618 A1 3/2016 Pundir et al.
 2016/0070644 A1 3/2016 D'Sa et al.
 2016/0070714 A1 3/2016 D'Sa et al.
 2016/0077744 A1 3/2016 Pundir et al.
 2016/0077945 A1 3/2016 Kalra et al.
 2016/0092125 A1 3/2016 Cowling et al.
 2016/0099844 A1 4/2016 Colgrove et al.
 2016/0117103 A1* 4/2016 Gallant G06F 3/0665
 711/114
 2016/0132396 A1 5/2016 Kimmel et al.
 2016/0139838 A1 5/2016 D'Sa et al.
 2016/0139849 A1 5/2016 Chaw et al.
 2016/0149763 A1 5/2016 Ingram et al.
 2016/0149766 A1 5/2016 Borowiec et al.
 2016/0154834 A1 6/2016 Friedman et al.
 2016/0179410 A1 6/2016 Haas et al.
 2016/0188370 A1 6/2016 Razin et al.
 2016/0188430 A1 6/2016 Nitta et al.
 2016/0197995 A1* 7/2016 Lu H04L 67/61
 709/219
 2016/0203043 A1 7/2016 Nazari et al.
 2016/0246522 A1 8/2016 Krishnamachari et al.
 2016/0283139 A1 9/2016 Brooker et al.
 2016/0336223 A1* 11/2016 Chase H01L 23/49827
 2016/0350192 A1 12/2016 Doherty et al.
 2016/0366223 A1* 12/2016 Mason H04L 67/1097
 2016/0371021 A1 12/2016 Goldberg et al.
 2017/0003892 A1 1/2017 Sekido et al.
 2017/0017413 A1 1/2017 Aston et al.
 2017/0031769 A1 2/2017 Zheng et al.
 2017/0031774 A1 2/2017 Bolen et al.
 2017/0032005 A1 2/2017 Zheng et al.
 2017/0046257 A1 2/2017 Babu et al.
 2017/0068599 A1 3/2017 Chiu et al.
 2017/0083535 A1 3/2017 Marchukov et al.
 2017/0097771 A1 4/2017 Krishnamachari et al.
 2017/0097873 A1 4/2017 Krishnamachari et al.
 2017/0109298 A1 4/2017 Kurita et al.
 2017/0123726 A1 5/2017 Sinclair et al.
 2017/0212690 A1 7/2017 Babu et al.
 2017/0212891 A1 7/2017 Pundir et al.
 2017/0212919 A1 7/2017 Li et al.
 2017/0220777 A1 8/2017 Wang et al.
 2017/0269980 A1 9/2017 Gupta et al.
 2017/0300248 A1 10/2017 Purohit et al.
 2017/0315740 A1 11/2017 Corsi et al.
 2017/0315878 A1 11/2017 Purohit et al.
 2017/0329593 A1 11/2017 McMullen
 2017/0351543 A1 12/2017 Kimura
 2018/0287951 A1 10/2018 Waskiewicz, Jr. et al.
 2022/0103436 A1 3/2022 Wright et al.

FOREIGN PATENT DOCUMENTS

EP 2693358 A1 2/2014
 EP 2735978 A1 5/2014
 WO 2006050455 A2 5/2006
 WO 2012132943 A1 10/2012
 WO 2013101947 A1 7/2013

OTHER PUBLICATIONS

Alvaraez C., "NetApp Deduplication for FAS and V-Series Deployment and Implementation Guide," Technical Report TR-3505, 2011, 75 pages.
 Amit et al., "Strategies for Mitigating the IOTLB Bottleneck," Technion—Israel Institute of Technology, IBM Research Haifa,

(56)

References Cited

OTHER PUBLICATIONS

WIOSCA 2010—Sixth Annual Workshop on the Interaction between Operating Systems and Computer Architecture, 2010, 12 pages.

Arpaci-Dusseau R., et al., “Log-Structured File Systems,” *Operating Systems: Three Easy Pieces* published by Arpaci-Dusseau Books, May 25, 2014, 15 pages.

Balakrishnan, M., et al., “CORFU: A Shared Log Design for Flash Clusters,” Microsoft Research Silicon Vally, University of California, San Diego, Apr. 2012, <https://www.usenix.org/conference/nsdi12/technical-sessions/presentation/balakrishnan>, 14 pages.

Ben-Yehuda et al., “The Price of Safety: Evaluating IOMMU Performance,” *Proceedings of the Linux Symposium*, vol. 1, Jun. 27-30, 2007, pp. 9-20.

Bitton D. et al., “Duplicate Record Elimination in Large Data Files,” Oct. 26, 1999, 11 pages.

Bogaerd, “Cdefutorial,” <http://oss.oetiker.ch/rrdtool/tut/cdefutorial.en.html> Date obtained from the internet, Sep. 9, 2014, 14 pages.

Bogaerd, “Rates, Normalizing and Consolidating,” <http://www.vandenbogaerd.nl/rrdtool/process.php> Date obtained from the internet: Sep. 9, 2014, 5 pages.

Bogaerd, “rrdtutorial,” <http://oss.oetiker.ch/rrdtool/lul/rrdtutorial.en.html> Date obtained from the internet, Sep. 9, 2014, 21 pages.

Chris K., et al., “How Many Primes are There?,” Nov. 2001, Retrieved from Internet: <https://web.archive.org/web/20011120073053/http://primes.utm.edu/howmany.shtml>, 5 pages.

CornwellM., “Anatomy of a Solid-state Drive,” *ACM Queue-Networks*, Oct. 2012, vol. 10 (10), pp. 1-7.

Culik K., et al., “Dense Multiway Trees,” *ACM Transactions on Database Systems*, Sep. 1981, vol. 6 (3), pp. 486-512.

Debnath B., et al., “FlashStore: High Throughput Persistent Key-Value Store,” *Proceedings of the VLDB Endowment VLDB Endowment*, Sep. 2010, vol. 3 (1-2), pp. 1414-1425.

Debnath, et al., “ChunkStash: Speeding up In line Storage Deduplication using Flash Memory,” *USENIX, USENIXATC '10*, Jun. 2010, 15 pages.

Dictionary, “Definition for References,” Retrieved from Internet: <http://www.dictionary.com/browse/reference?s=t> on Dec. 23, 2017, 5 pages.

Enclopedia Entry, “Pointers vs. References,” Retrieved from Internet: <https://www.geeksforgeeks.org/pointers-vs-references-cpp/> on Dec. 23, 2017, 5 pages.

Extended European Search Report for Application No. 20201330.6 dated Dec. 8, 2020, 7 pages.

Extended European Search Report for Application No. 20205866.5 dated Dec. 8, 2020, 7 pages.

Extended European Search Report dated Apr. 9, 2018 for EP Application No. 15855480.8 filed Oct. 22, 2015, 7 pages.

Fan, et al., “MemC3: Compact and Concurrent MemCache with Dumber Caching and Smarter Hashing,” *USENIX NSDI '13*, Apr. 2013, pp. 371-384.

Gal E., et al., “Algorithms and Data Structures for Flash Memories,” *ACM Computing Surveys (CSUR) Archive*, Publisher ACM, New York City, NY, USA, Jun. 2005, vol. 37 (2), pp. 138-163.

Gray J., et al., “Flash Disk Opportunity for Server Applications,” *Queue—Enterprise Flash Storage*, Jul.-Aug. 2008, vol. 6 (4), pp. 18-23.

Gulati A., et al., “BASIL: Automated IO Load Balancing Across Storage Devices,” *Proceedings of the 8th USENIX Conference on File and Storage Technologies, FAST'10*, Berkeley, CA, USA, 2010, 14 pages.

Handy J., “SSSI Tech Notes: How Controllers Maximize SSD Life,” *SNIA*, Jan. 2013, pp. 1-20.

Hwang K., et al., “RAID-x: A New Distributed Disk Array for I/O-centric Cluster Computing,” *IEEE High-Performance Distributed Computing*, Aug. 2000, pp. 279-286.

IBM Technical Disclosure Bulletin, “Optical Disk Axial Runout Test”, vol. 36, No. 10, NN9310227, Oct. 1, 1993, 3 pages.

Intel, Product Specification—Intel® Solid-State Drive DC S3700, Jun. 2013, 34 pages.

International Search Report and Written Opinion for Application No. PCT/EP2014/071446 dated Apr. 1, 2015, 14 pages.

International Search Report and Written Opinion for Application No. PCT/US2012/071844 dated Mar. 1, 2013, 12 pages.

International Search Report and Written Opinion for Application No. PCT/US2014/035284 dated Apr. 1, 2015, 8 pages.

International Search Report and Written Opinion for Application No. PCT/US2014/055138 dated Dec. 12, 2014, 13 pages.

International Search Report and Written Opinion for Application No. PCT/US2014/058728 dated Dec. 16, 2014, 11 pages.

International Search Report and Written Opinion for Application No. PCT/US2014/060031 dated Jan. 26, 2015, 9 pages.

International Search Report and Written Opinion for Application No. PCT/US2014/071446 dated Apr. 1, 2015, 13 pages.

International Search Report and Written Opinion for Application No. PCT/US2014/071465 dated Mar. 25, 2015, 12 pages.

International Search Report and Written Opinion for Application No. PCT/US2014/071484 dated Mar. 25, 2015, 9 pages.

International Search Report and Written Opinion for Application No. PCT/US2014/071581 dated Apr. 10, 2015, 9 pages.

International Search Report and Written Opinion for Application No. PCT/US2014/071635 dated Mar. 31, 2015, 13 pages.

International Search Report and Written Opinion for Application No. PCT/US2015/016625 dated Sep. 17, 2015, 8 pages.

International Search Report and Written Opinion for Application No. PCT/US2015/021285 dated Jun. 23, 2015, 8 pages.

International Search Report and Written Opinion for Application No. PCT/US2015/024067 dated Jul. 8, 2015, 7 pages.

International Search Report and Written Opinion for Application No. PCT/US2015/048800 dated Nov. 25, 2015, 11 pages.

International Search Report and Written Opinion for Application No. PCT/US2015/048810 dated Dec. 23, 2015, 11 pages.

International Search Report and Written Opinion for Application No. PCT/US2015/048833 dated Nov. 25, 2015, 11 pages.

International Search Report and Written Opinion for Application No. PCT/US2015/056932 dated Jan. 21, 2016, 11 pages.

International Search Report and Written Opinion for Application No. PCT/US2015/057532 dated Feb. 9, 2016, 12 pages.

International Search Report and Written Opinion for Application No. PCT/US2016/059943 dated May 15, 2017, 14 pages.

International Search Report and Written Opinion for Application No. PCT/US2018/025951, dated Jul. 18, 2018, 16 pages.

Jones, M., “Next-generation Linux File Systems: NiLFS(2) and Eofs,” IBM, 2009.

Jude Nelson “Syndicate: Building a Virtual Cloud Storage Service Through Service Composition” Princeton University, 2013, pp. 1-14.

Kagel A.S., “Two-way Merge Sort,” *Dictionary of Algorithms and Data Structures [online]*, retrieved on Jan. 28, 2015, Retrieved from the Internet : URL: <http://xlinux.nist.gov/dads/HTML/twomerge.html>, May 2005, 1 page.

Konishi, R., et al., “Filesystem Support for Continuous Snapshotting,” *Ottawa Linux Symposium*, 2007.

Lampert L., “The Part-Time Parliament,” *ACM Transactions on Computer Systems*, May 1998, vol. 16 (2), pp. 133-169.

Leventhal A.H., “A File System All its Own,” *Communications of the ACM Queue*, May 2013, vol. 56 (5), pp. 64-67.

Lim H., et al., “SILT: A Memory-Efficient, High-Performance Key-Value Store,” *Proceedings of the 23rd ACM Symposium on Operating Systems Principles (SOSP'11)*, Oct. 23-26, 2011, pp. 1-13.

Metreveli, Z., et al., “CPHash: A Cache-Partitioned Hash Table,” 2011, 10 pages. URL: <https://people.csail.mit.edu/nickolai/papers/metrevelicphash-%20tr.pdf>.

Moshayedi M., et al., “Enterprise SSDs,” *ACM Queue—Enterprise Flash Storage*, Jul.-Aug. 2008, vol. 6 (4), pp. 32-39.

Odlevak, “Simple Kexec Example”, <https://www.linux.com/blog/simple-kexec-example>, accessed on Feb. 5, 2019 (Year: 2011), 4 pages.

Oetiker, “RRDfetch,” <http://oss.oetiker.ch/rrdtool/doc/rrdfetch.en.html>, Date obtained from the internet: Sep. 9, 2014, 5 pages.

Oetiker, “RRDtool,” Retrieved from the Internet: Sep. 9, 2014, 5 pages, URL: <http://loss.oetiker.ch/rrdtool/doc/rrdtool.en.html>.

(56)

References Cited

OTHER PUBLICATIONS

O'Neil P., et al., "The Log-structured Merge-tree (lsm-tree)," *Acta Informatica*, 33, 1996, pp. 351-385.

Ongaro D., et al., "In Search of an Understandable Consensus Algorithm (Extended Version)," 2014, 18 pages.

Ongaro D., et al., "In Search of an Understandable Consensus Algorithm," Stanford University, URL: <https://ramcloud.stanford.edu/wiki/download/attachments/11370504/raft.pdf>, May 2013, 14 pages.

Pagh R., et al., "Cuckoo Hashing," Elsevier Science, Dec. 8, 2003, pp. 1-27.

Pagh R., et al., "Cuckoo Hashing for Undergraduates," IT University of Copenhagen, Mar. 27, 2006, pp. 1-6.

"Pivot Root," Die.net, retrieved from https://linux.die.net/pivot_root on Nov. 12, 2011, 2 pages.

Proceedings of the FAST 2002 Conference on File Storage Technologies, Monterey, California, USA, Jan. 28-30, 2002, 14 pages.

Rosenblum M., et al., "The Design and Implementation of a Log-Structured File System," In Proceedings of ACM Transactions on Computer Systems, vol. 10(1), Feb. 1992, pp. 26-52.

Rosenblum M., et al., "The Design and Implementation of a Log-Structured File System," Proceedings of the 13th ACM Symposium on Operating Systems Principles, (SUN00007382-SUN00007396), Jul. 1991, 15 pages.

Rosenblum M., et al., "The Design and Implementation of a Log-Structured File System," (SUN00006867-SUN00006881), Jul. 1991, 15 pages.

Rosenblum M., et al., "The LFS Storage Manager," USENIX Technical Conference, Anaheim, CA, (Sun 00007397-SUN00007412), Jun. 1990, 16 pages.

Rosenblum M., et al., "The LFS Storage Manager," USENIX Technical Conference, Computer Science Division, Electrical Engin. and Computer Sciences, Anaheim, CA, presented at Summer '90 USENIX Technical Conference, (SUN00006851-SUN00006866), Jun. 1990, 16 pages.

Rosenblum M., "The Design and Implementation of a Log-Structured File System," UC Berkeley, 1992, pp. 1-101.

Sears., et al., "Bism: A General Purpose Log Structured Merge Tree," Proceedings of the 2012 ACM SIGMOD International Conference on Management, 2012, 12 pages.

Seltzer M., et al., "An Implementation of a Log Structured File System for UNIX," Winter USENIX, San Diego, CA, Jan. 25-29, 1993, pp. 1-18.

Seltzer M.I., et al., "File System Performance and Transaction Support," University of California at Berkeley Dissertation, 1992, 131 pages.

Smith K., "Garbage Collection," Sand Force, Flash Memory Summit, Santa Clara, CA, Aug. 2011, pp. 1-9.

Stoica I., et al., "Chord: A Scalable Peer-to-Peer Lookup Service for Internet Applications." SIGCOMM'01, Aug. 2001, 12 pages.

Supplementary European Search Report for Application No. EP12863372 dated Jul. 16, 2015, 7 pages.

Texas Instruments, User Guide, TMS320C674x/OMAP-L1 x Processor Serial ATA (SATA) Controller, Mar. 2011, 76 Pages.

Twigg A., et al., "Stratified B-trees and Versioned Dictionaries," Proceedings of the 3rd US EN IX Conference on Hot Topics in Storage and File Systems, 2011, vol. 11, pp. 1-5.

Waskiewicz P.J., "Scaling With Multiple Network Namespaces in a Single Application," Netdev 1.2—The Technical Conference on Linux Networking, retrieved from internet: URL; <https://netdevconf.org/1.2/papers/pj-netdev-1.2.pdf> Dec. 12, 2016, 5 pages.

Wei Y., et al., "NAND Flash Storage Device Performance in Linux File System," 6th International Conference on Computer Sciences and Convergence Information Technology (ICIT), 2011.

Wikipedia, "Cuckoo Hashing," http://en.wikipedia.org/wiki/Cuckoo_hash, Apr. 2013, pp. 1-5.

Wilkes J., et al., "The Hp Auto Raid Hierarchical Storage System," Operating System Review, ACM, New York, NY, Dec. 1, 1995, vol. 29 (5), pp. 96-108.

Wu P-L., et al., "A File-System-Aware FTL Design for Flash-Memory Storage Systems," IEEE, Design, Automation & Test in Europe Conference & Exhibition, 2009, pp. 1-6.

Yossef., "Building Murphy-Compatible Embedded Linux Systems," Proceedings of the Linux Symposium, Ottawa, Ontario Canada, Jul. 2005, 24 pages.

European Office Action for Application No. EP20201330 dated Oct. 7, 2022, 5 pages.

European Office Action for Application No. EP20205866 dated Oct. 10, 2022, 6 pages.

* cited by examiner

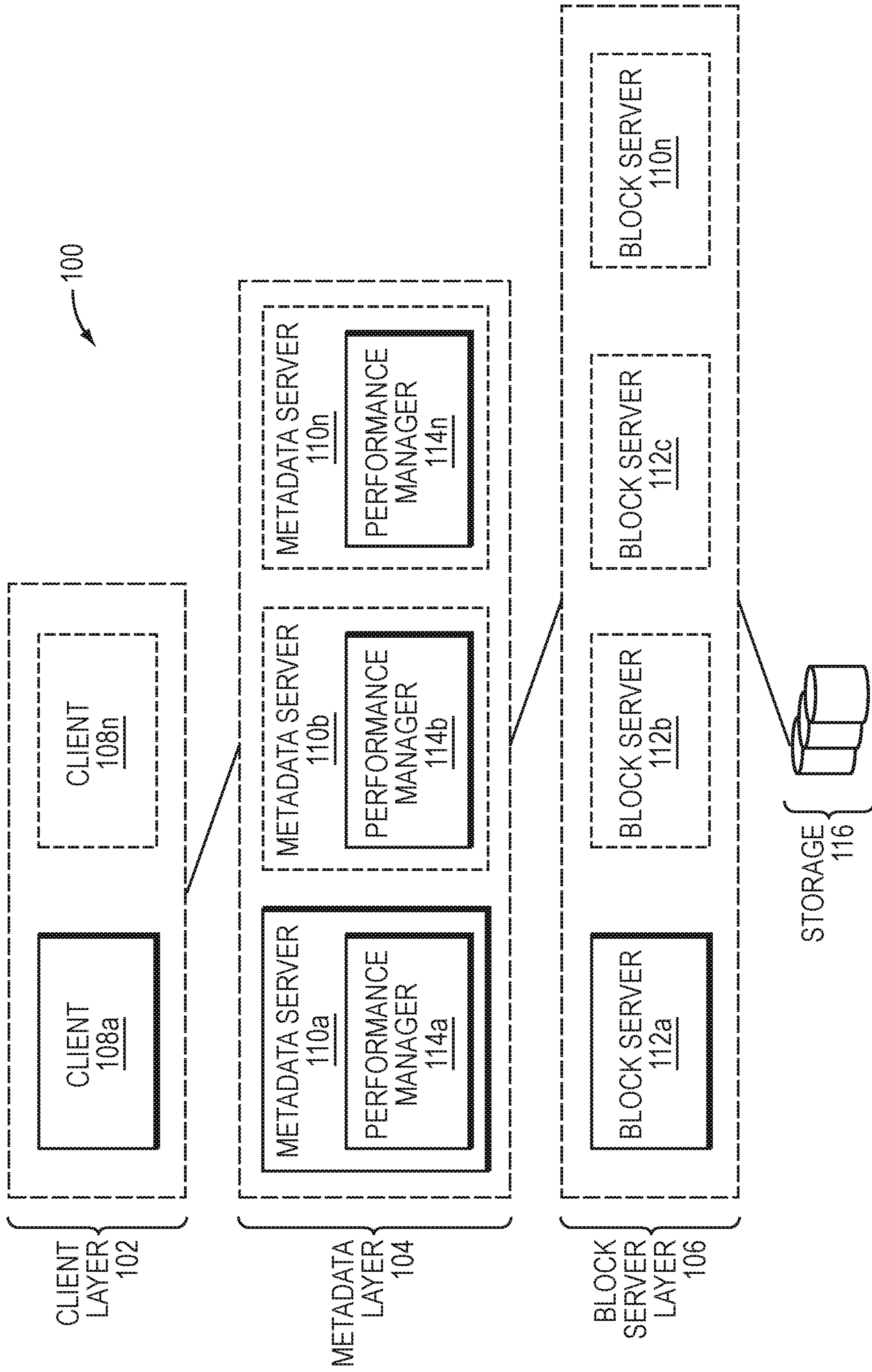

FIG. 1A

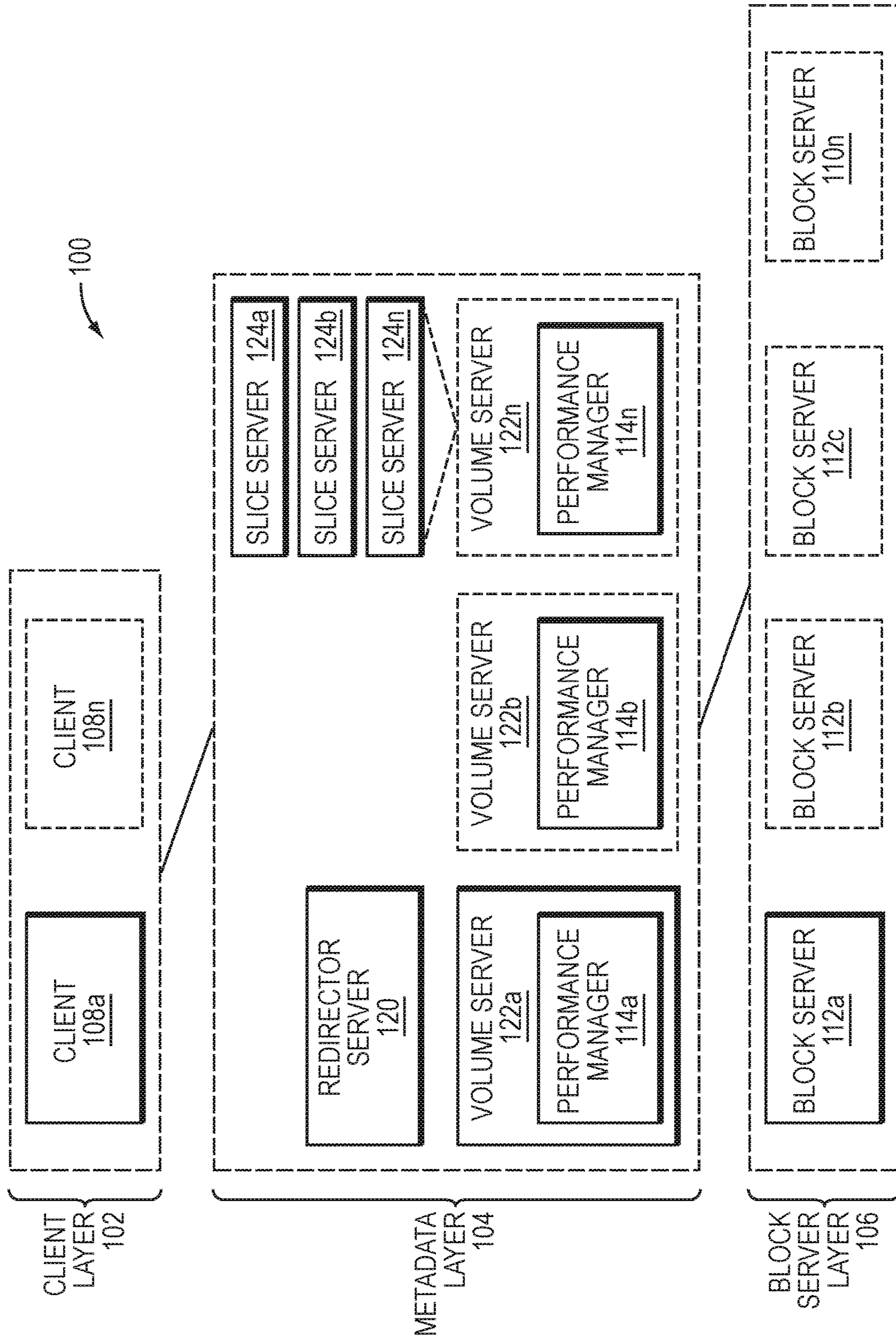

FIG. 1B

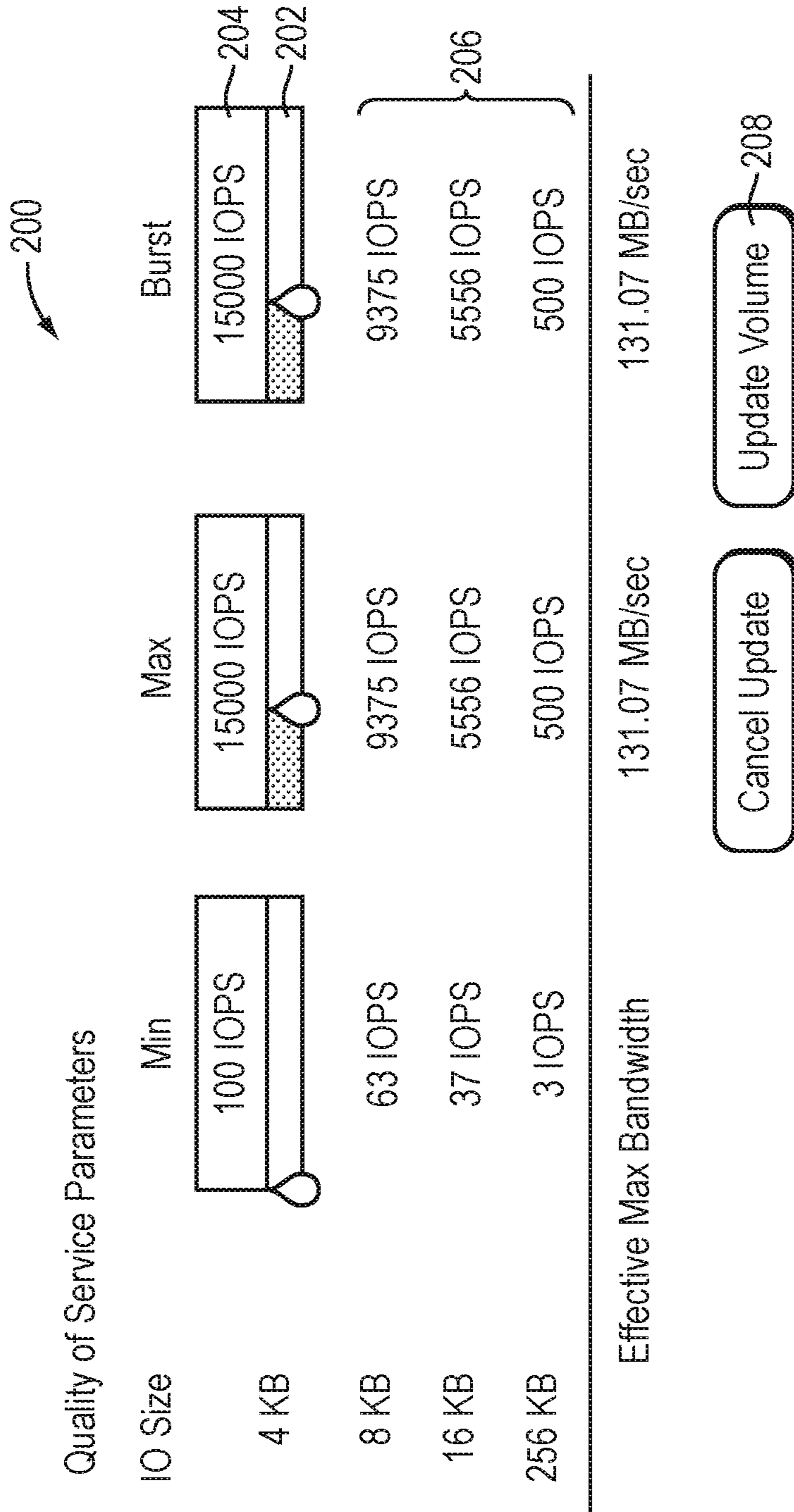

FIG. 2

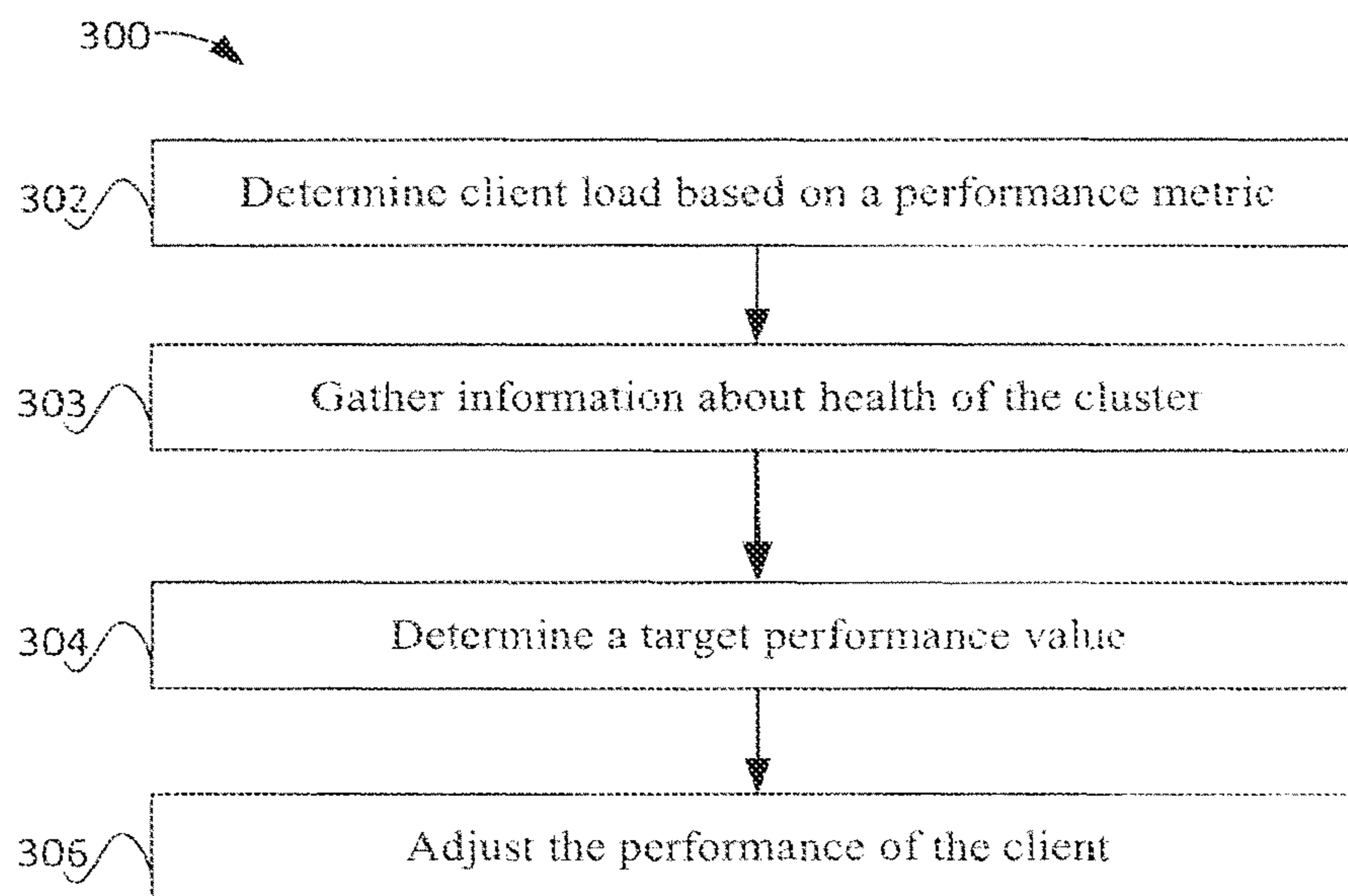

FIG. 3

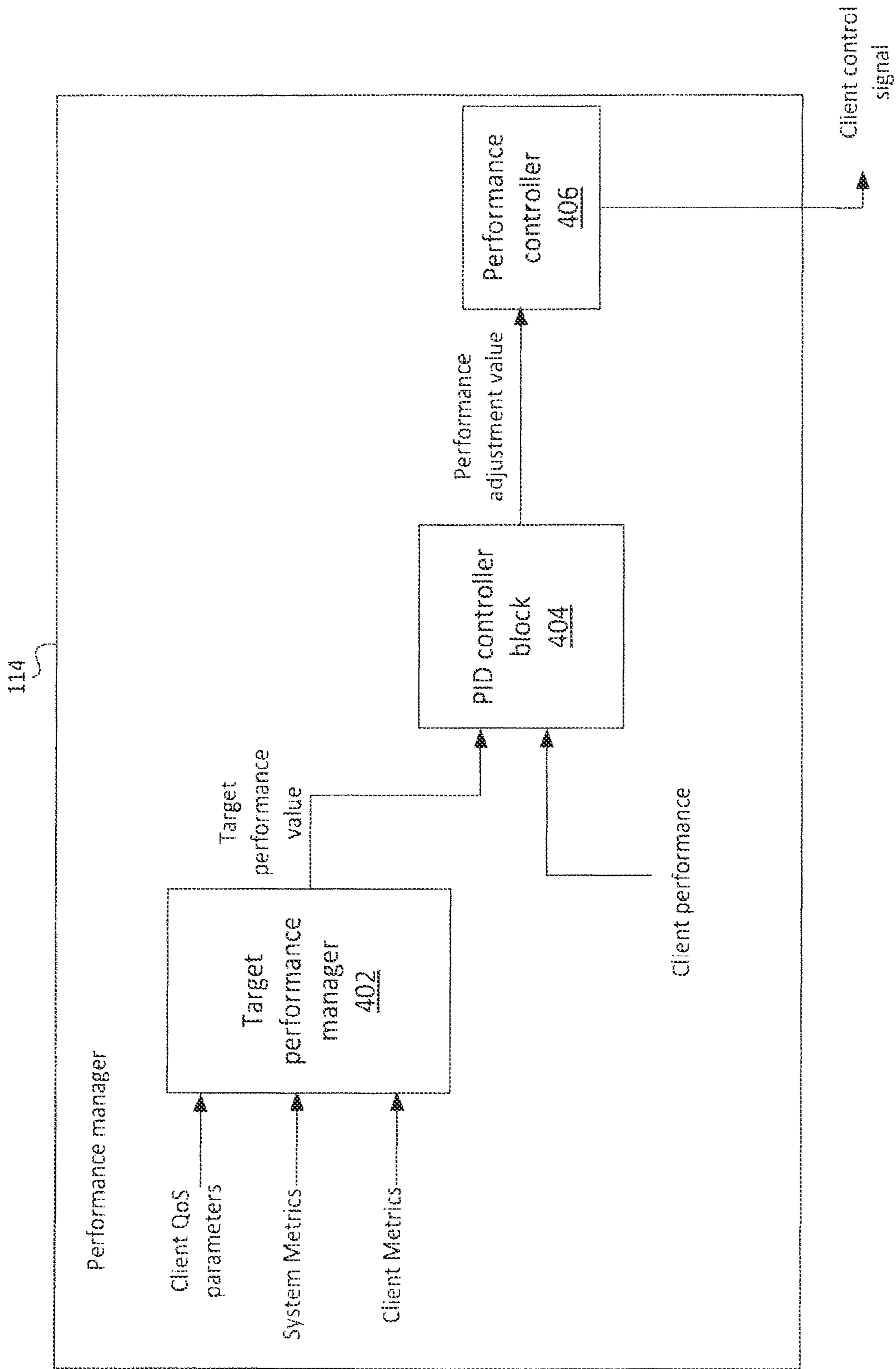

FIG. 4

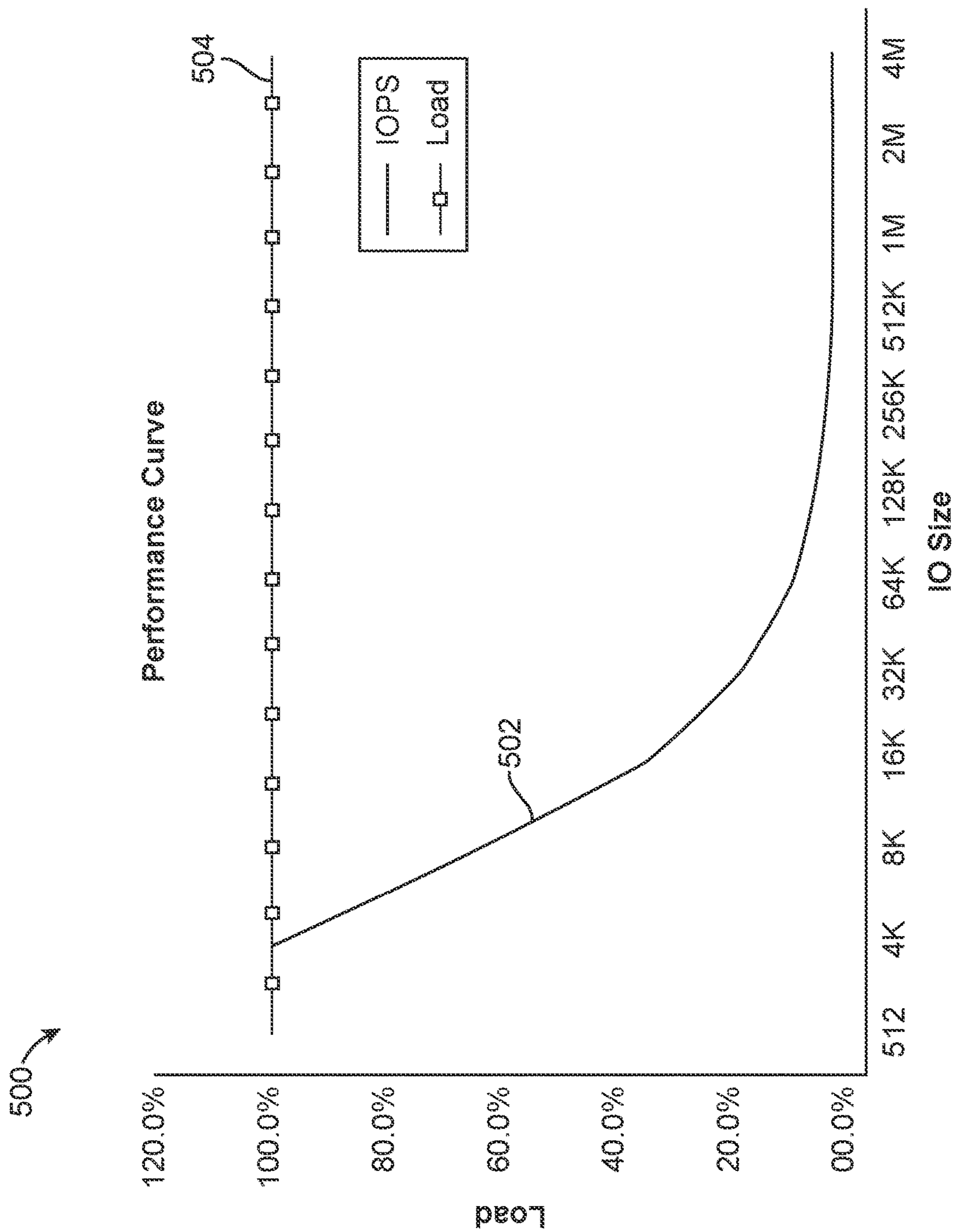

FIG. 5

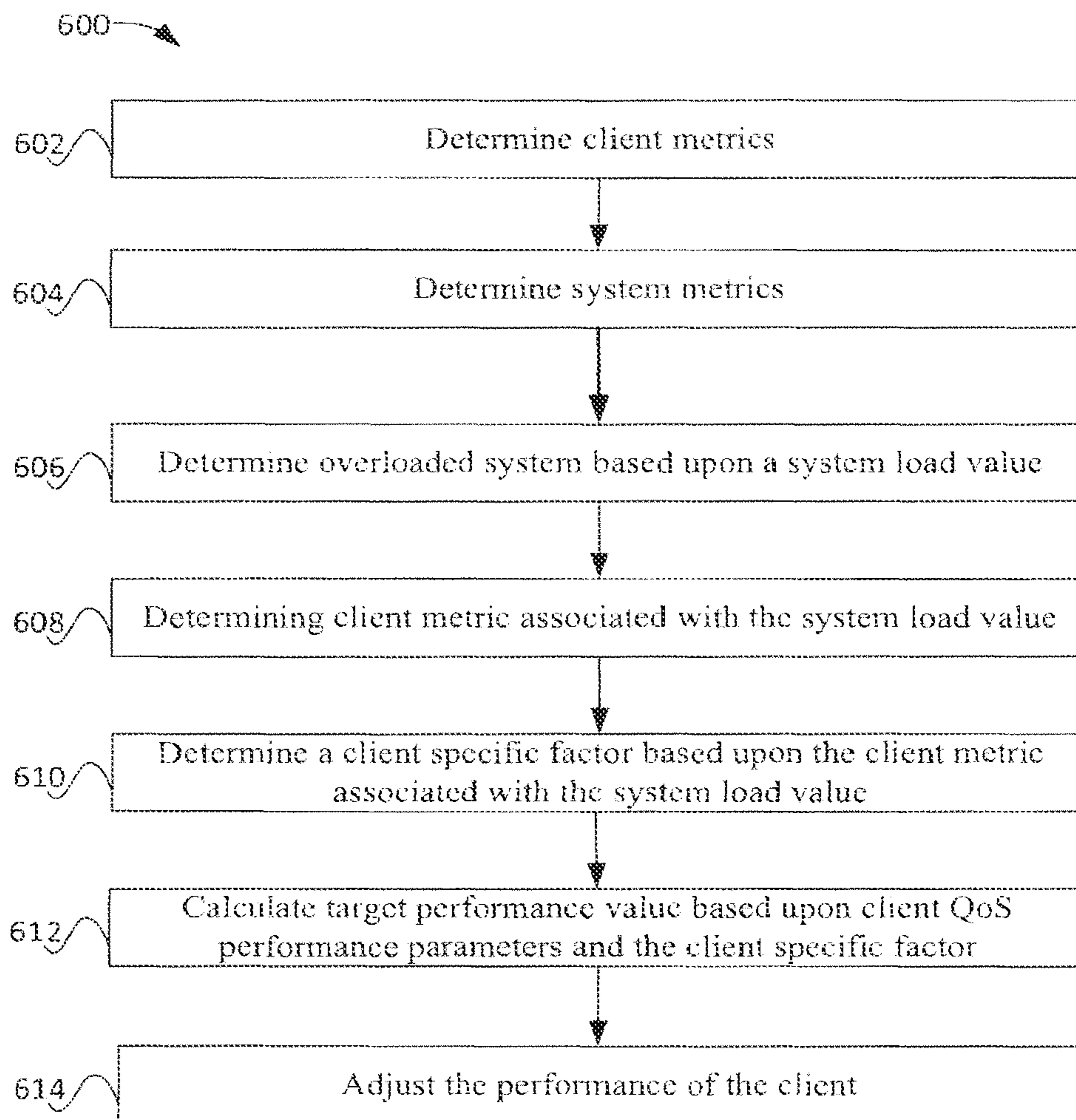

FIG. 6

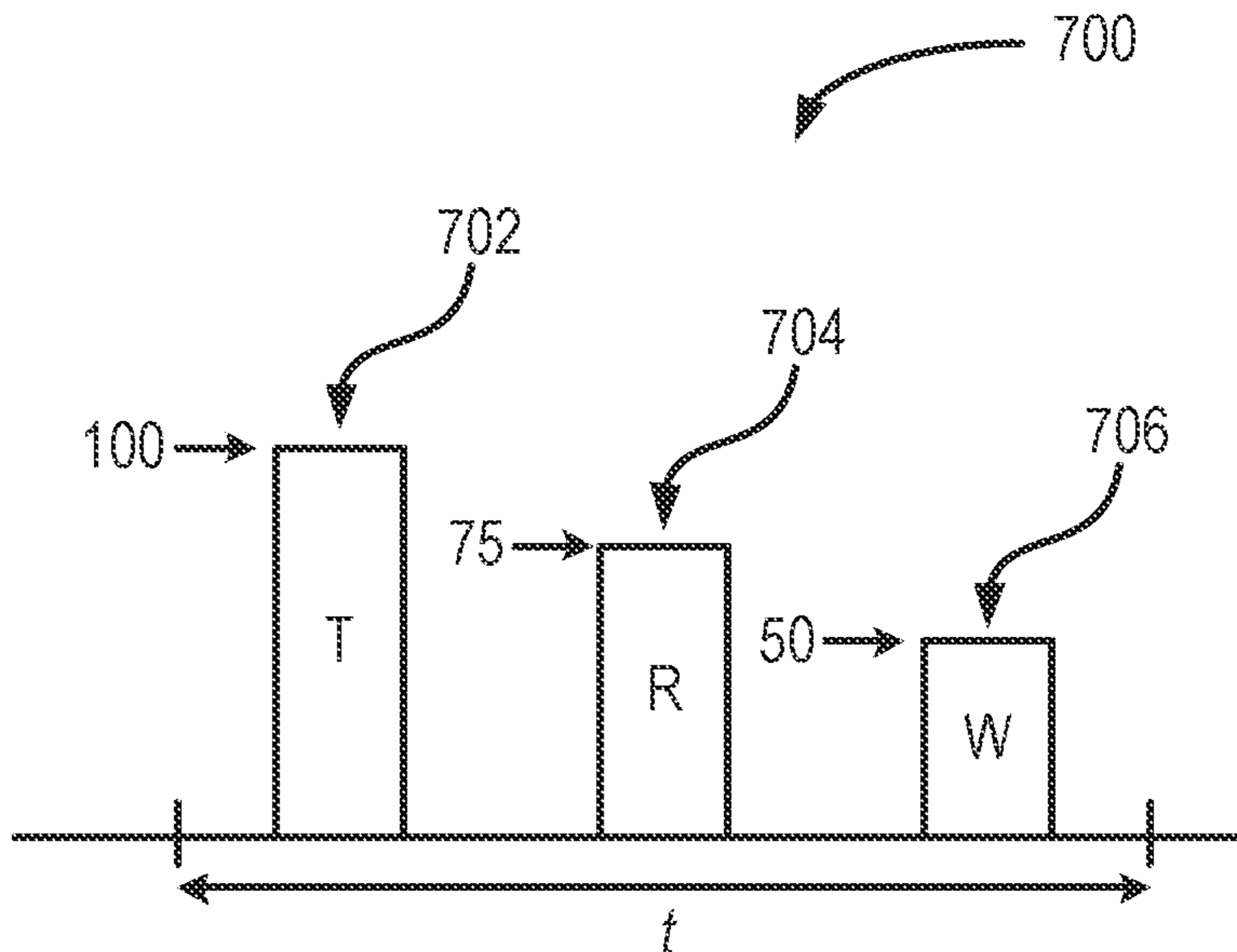

FIG. 7A

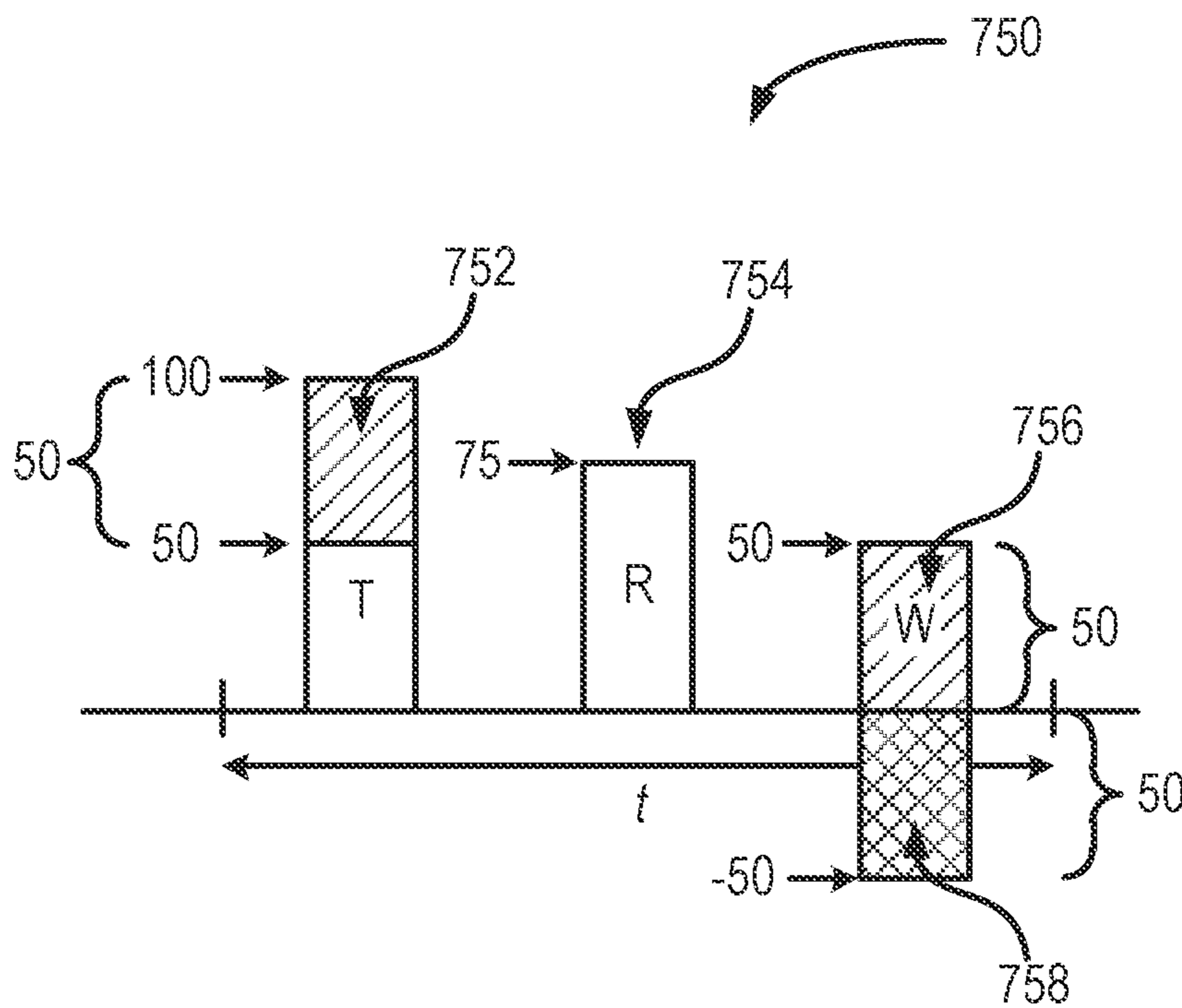

FIG. 7C

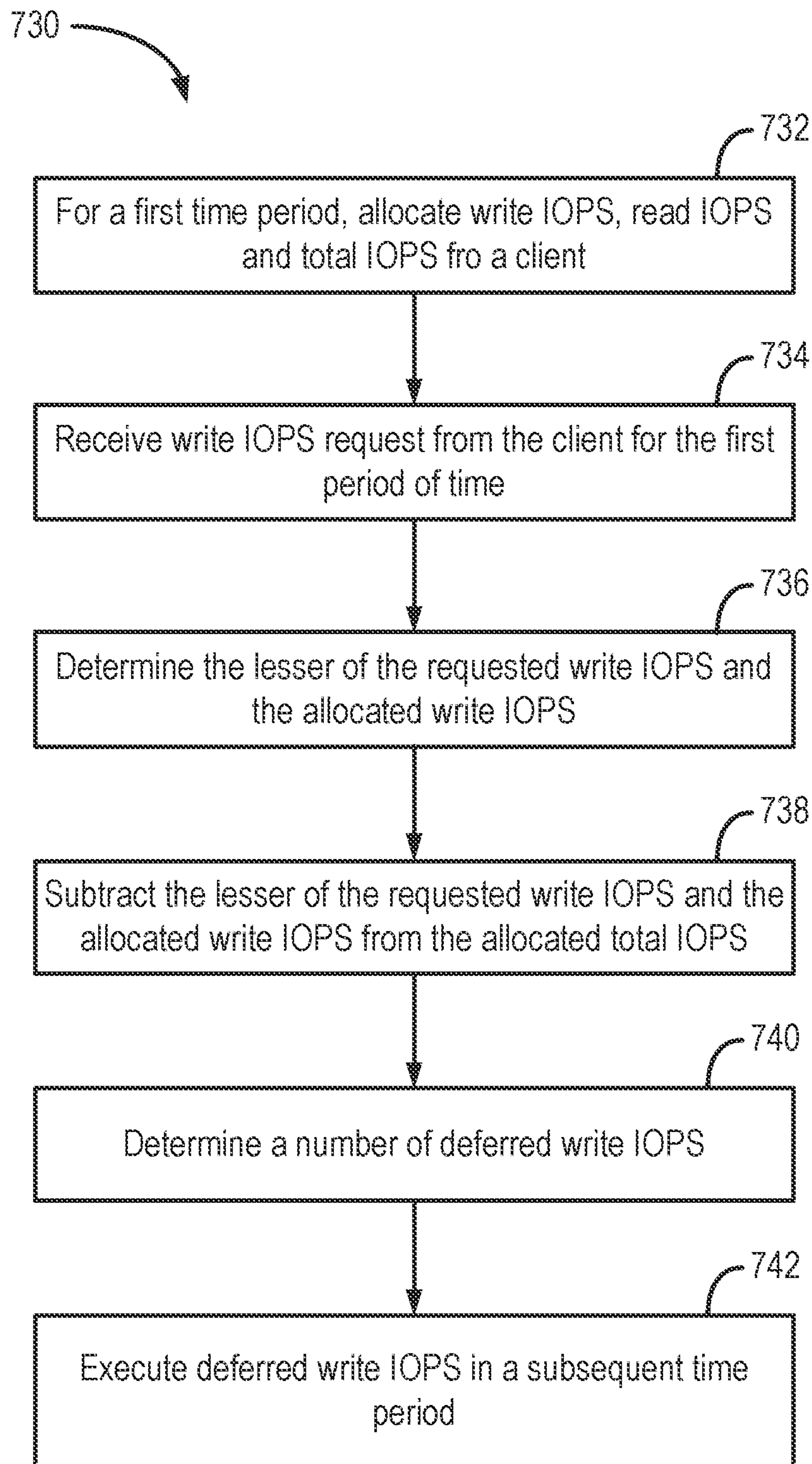

FIG. 7B

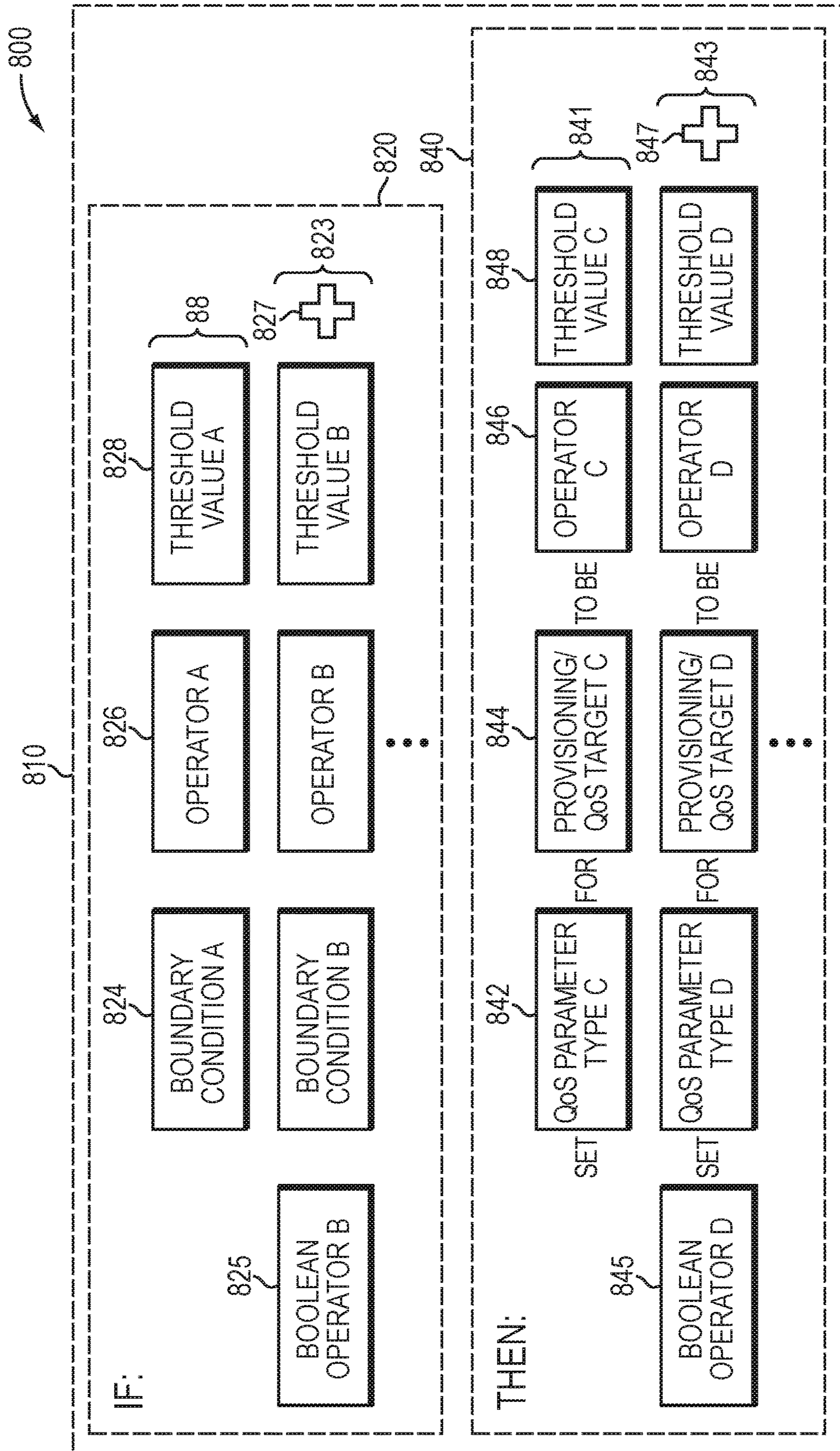

FIG. 8

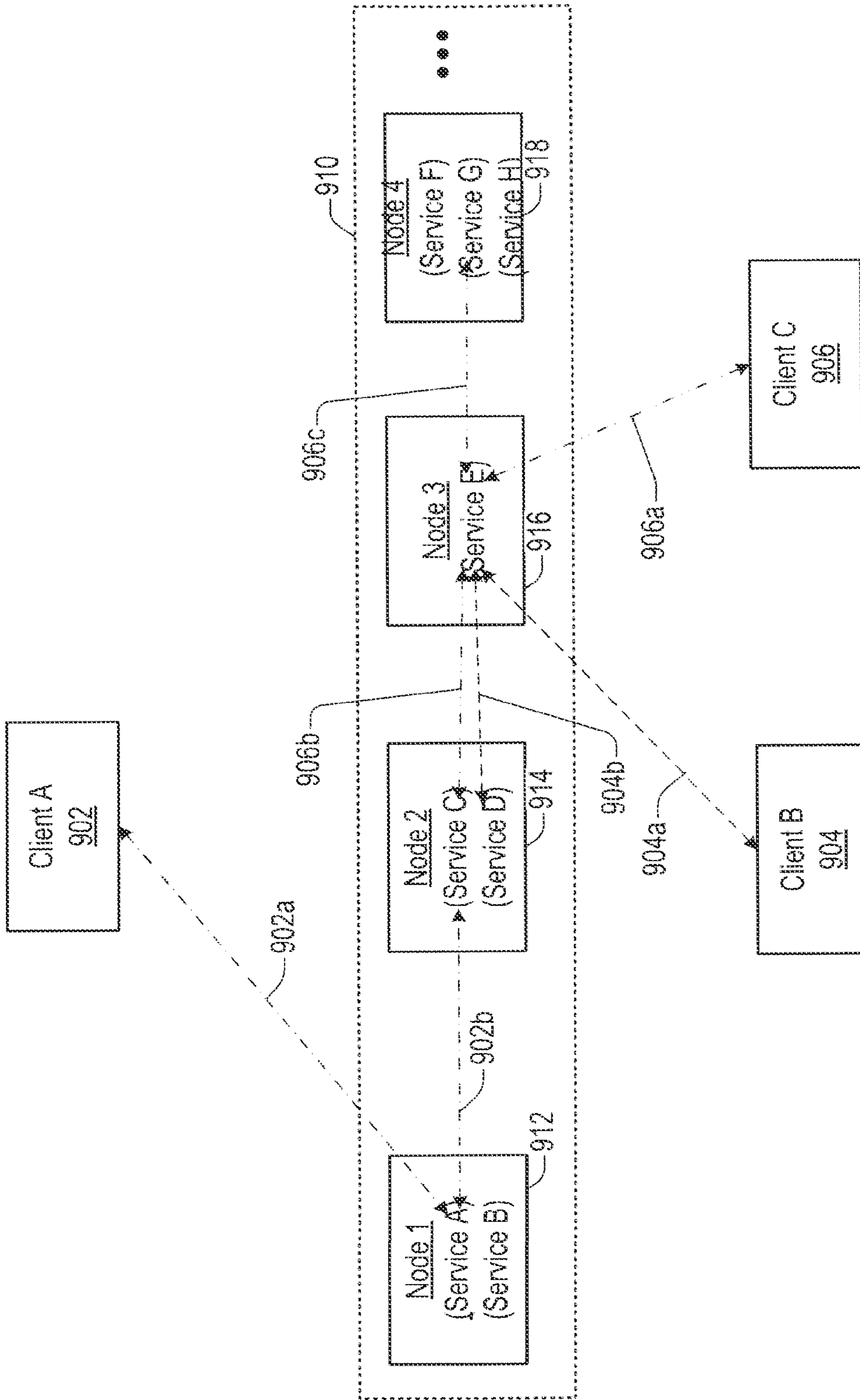

Fig. 9

QUALITY OF SERVICE POLICY SETS

CROSS-REFERENCE TO RELATED PATENTS

This application is a continuation of U.S. patent application Ser. No. 17/203,094, filed on Mar. 16, 2021, which is a continuation of U.S. patent application Ser. No. 16/867,418, filed on May 5, 2020, now U.S. Pat. No. 10,997,098, which is a continuation of U.S. patent application Ser. No. 15/270,973, filed on Sep. 20, 2016, now U.S. Pat. No. 10,642,763, all of which are hereby incorporated by reference in their entirety for all purposes.

BACKGROUND

The following description is provided to assist the understanding of the reader. None of the information provided is admitted to be prior art.

In data storage architectures, a client's data may be stored in a volume. The client can access the client data from the volume via one or more volume servers coupled to the volume. The volume servers can map the locations of the data specified by the client, such as file name, drive name, etc., into unique identifiers that are specific to the location of the client's data on the volume. Using the volume server as an interface to the volume allows the freedom to distribute the data evenly over the one or more volumes. The even distribution of data can be beneficial in terms of volume and system performance.

Read and write requests of the client are typically transformed into read and/or write input/output operations (IOPS). For example, a file read request by a client can be transformed into one or more read IOPS of some size. Similarly, a file write request by the client can be transformed into one or more write IOPS.

BRIEF DESCRIPTION OF THE DRAWINGS

The foregoing and other features of the present disclosure will become more fully apparent from the following description and appended claims, taken in conjunction with the accompanying drawings.

FIG. 1A depicts a simplified system for performance management in a storage system in accordance with an illustrative implementation.

FIG. 1B depicts a more detailed example of a system in accordance with an illustrative implementation.

FIG. 2 depicts a user interface for setting quality of service parameters in accordance with an illustrative implementation.

FIG. 3 depicts a simplified flowchart of a method of performing performance management in accordance with an illustrative implementation.

FIG. 4 depicts a more detailed example of adjusting performance using a performance manager in accordance with an illustrative implementation.

FIG. 5 depicts a performance curve comparing the size of input/output operations with system load in accordance with an illustrative implementation.

FIG. 6 depicts a simplified flowchart of a method of performing performance management that matches an overloaded system metric with a client metric in accordance with an illustrative implementation.

FIG. 7A illustrates an example allocation of input-output operations to a client over a period of time in accordance with an illustrative implementation.

FIG. 7B shows an example flow diagram of a process for independent control of read IOPS and write IOPS associated with a client in accordance with an illustrative implementation.

FIG. 7C shows example target IOPS associated with a client over a time period in accordance with an illustrative implementation.

FIG. 8 shows an example QoS Interface GUI 800 which may be configured or designed to enable service providers, users, and/or other entities to dynamically define and/or create different performance classes of use and/or to define performance/QoS related customizations in the storage system in accordance with an illustrative implementation.

FIG. 9 shows a portion of a storage system in accordance with an illustrative implementation.

DETAILED DESCRIPTION OF EXAMPLE EMBODIMENTS

Overview

In one embodiment, a method for managing input-output operations within a system including at least one client and storage system includes receiving, at a processor, a number of allocated total input-output operations (IOPS), a number of allocated read IOPS and a number of allocated write IOPS for at least one client accessing a storage system during a first time period. Each of the number of allocated read IOPS and the number of allocated write IOPS is not greater than the number of allocated total IOPS. The method further includes receiving, at the processor, a requested number of write IOPS associated with the at least one client's request to write to the storage system. The method also includes determining, at the processor, a target write IOPS based on the number of allocated total IOPS, the number of allocated write IOPS and the requested number of write IOPS. The method further includes executing, by the processor, the determined target write IOPS within the first time period.

In one or more embodiments, a system includes a storage system and a processor coupled to the storage system. The storage system is configured to store client data. The processor is configured to receive a number of allocated total input-output operations (IOPS), a number of allocated read IOPS and a number of allocated write IOPS for at least one client accessing a storage system during a first time period. Each of the number of allocated read IOPS and the number of allocated write IOPS is not greater than the number of allocated total IOPS. The processor is further configured to receiving a requested number of write IOPS associated with the at least one client's request to write to the storage system. The processor is additionally configured to determine a target write IOPS based on the number of allocated total IOPS, the number of allocated write IOPS, and the requested number of write IOPS. The processor is also configured to execute the determined target write IOPS within the first time period.

The foregoing summary is illustrative only and is not intended to be in any way limiting. In addition to the illustrative aspects, implementations, and features described above, further aspects, implementations, and features will become apparent by reference to the following drawings and the detailed description.

Specific Example Embodiments

One or more different inventions may be described in the present application. Further, for one or more of the invention(s) described herein, numerous embodiments may be described in this patent application, and are presented for illustrative purposes only. The described embodiments are not intended to be limiting in any sense. One or more of the invention(s) may be widely applicable to numerous embodiments, as is readily apparent from the disclosure. These embodiments are described in sufficient detail to enable those skilled in the art to practice one or more of the invention(s), and it is to be understood that other embodiments may be utilized and that structural, logical, software, electrical and other changes may be made without departing from the scope of the one or more of the invention(s). Accordingly, those skilled in the art will recognize that the one or more of the invention(s) may be practiced with various modifications and alterations. Particular features of one or more of the invention(s) may be described with reference to one or more particular embodiments or figures that form a part of the present disclosure, and in which are shown, by way of illustration, specific embodiments of one or more of the invention(s). It should be understood, however, that such features are not limited to usage in the one or more particular embodiments or figures with reference to which they are described. The present disclosure is neither a literal description of all embodiments of one or more of the invention(s) nor a listing of features of one or more of the invention(s) that must be present in all embodiments.

Headings of sections provided in this patent application and the title of this patent application are for convenience only, and are not to be taken as limiting the disclosure in any way. Devices that are in communication with each other need not be in continuous communication with each other, unless expressly specified otherwise. In addition, devices that are in communication with each other may communicate directly or indirectly through one or more intermediaries. A description of an embodiment with several components in communication with each other does not imply that all such components are required. To the contrary, a variety of optional components are described to illustrate the wide variety of possible embodiments of one or more of the invention(s).

Further, although process steps, method steps, algorithms or the like may be described in a sequential order, such processes, methods and algorithms may be configured to work in alternate orders. In other words, any sequence or order of steps that may be described in this patent application does not, in and of itself, indicate a requirement that the steps be performed in that order. The steps of described processes may be performed in any order practical. Further, some steps may be performed simultaneously despite being described or implied as occurring non-simultaneously (e.g., because one step is described after the other step). Moreover, the illustration of a process by its depiction in a drawing does not imply that the illustrated process is exclusive of other variations and modifications thereto, does not imply that the illustrated process or any of its steps are necessary to one or more of the invention(s), and does not imply that the illustrated process is preferred.

When a single device or article is described, it will be readily apparent that more than one device/article (whether or not they cooperate) may be used in place of a single device/article. Similarly, where more than one device or article is described (whether or not they cooperate), it will be readily apparent that a single device/article may be used in

place of the more than one device or article. The functionality and/or the features of a device may be alternatively embodied by one or more other devices that are not explicitly described as having such functionality/features. Thus, other embodiments of one or more of the invention(s) need not include the device itself.

Techniques and mechanisms described or reference herein will sometimes be described in singular form for clarity. However, it should be noted that particular embodiments include multiple iterations of a technique or multiple instantiations of a mechanism unless noted otherwise.

DETAILED DESCRIPTION

Described herein are techniques for a performance management storage system. In the following description, for purposes of explanation, numerous examples and specific details are set forth in order to provide a thorough understanding of various implementations. Particular implementations as defined by the claims may include some or all of the features in these examples alone or in combination with other features described below, and may further include modifications and equivalents of the features and concepts described herein.

Storage System

FIG. 1A depicts a simplified system for performance management in a storage system **100** in accordance with an illustrative implementation. System **100** includes a client layer **102**, a metadata layer **104**, a block server layer **106**, and storage **116**.

Before discussing how particular implementations manage performance of clients **108**, the structure of a possible system is described. Client layer **102** includes one or more clients **108a-108n**. Clients **108** include client processes that may exist on one or more physical machines. When the term “client” is used in the disclosure, the action being performed may be performed by a client process. A client process is responsible for storing, retrieving, and deleting data in system **100**. A client process may address pieces of data depending on the nature of the storage system and the format of the data stored. For example, the client process may reference data using a client address. The client address may take different forms. For example, in a storage system that uses file storage, client **108** may reference a particular volume or partition, and a file name. With object storage, the client address may be a unique object name. For block storage, the client address may be a volume or partition, and a block address. Clients **108** communicate with metadata layer **104** using different protocols, such as small computer system interface (SCSI), Internet small computer system interface (iSCSI), fibre channel (FC), common Internet file system (CIFS), network file system (NFS), hypertext transfer protocol (HTTP), web-based distributed authoring and versioning (WebDAV), or a custom protocol.

Metadata layer **104** includes one or more metadata servers **110a-110n**. Performance managers **114** may be located on metadata servers **110a-110n**. Block server layer **106** includes one or more block servers **112a-112n**. Block servers **112a-112n** are coupled to storage **116**, which stores volume data for clients **108**. Each client **108** may be associated with a volume. In one implementation, only one client **108** accesses data in a volume; however, multiple clients **108** may access data in a single volume.

Storage **116** can include multiple solid state drives (SSDs). In one implementation, storage **116** can be a cluster of individual drives coupled together via a network. When the term “cluster” is used, it will be recognized that cluster

5

may represent a storage system that includes multiple disks that may not be networked together. In one implementation, storage **116** uses solid state memory to store persistent data. SSDs use microchips that store data in non-volatile memory chips and contain no moving parts. One consequence of this is that SSDs allow random access to data in different drives in an optimized manner as compared to drives with spinning disks. Read or write requests to non-sequential portions of SSDs can be performed in a comparable amount of time as compared to sequential read or write requests. In contrast, if spinning disks were used, random read/writes would not be efficient since inserting a read/write head at various random locations to read data results in slower data access than if the data is read from sequential locations. Accordingly, using electromechanical disk storage can require that a client's volume of data be concentrated in a small relatively sequential portion of the cluster to avoid slower data access to non-sequential data. Using SSDs removes this limitation.

In various implementations, non-sequentially storing data in storage **116** is based upon breaking data up into one more storage units, e.g., data blocks. A data block, therefore, is the raw data for a volume and may be the smallest addressable unit of data. The metadata layer **104** or the client layer **102** can break data into data blocks. The data blocks can then be stored on multiple block servers **112**. Data blocks can be of a fixed size, can be initially a fixed size but compressed, or can be of a variable size. Data blocks can also be segmented based on the contextual content of the block. For example, data of a particular type may have a larger data block size compared to other types of data. Maintaining segmentation of the blocks on a write (and corresponding re-assembly on a read) may occur in client layer **102** and/or metadata layer **104**. Also, compression may occur in client layer **102**, metadata layer **104**, and/or block server layer **106**.

In addition to storing data non-sequentially, data blocks can be stored to achieve substantially even distribution across the storage system. In various examples, even distribution can be based upon a unique block identifier. A block identifier can be an identifier that is determined based on the content of the data block, such as by a hash of the content. The block identifier is unique to that block of data. For example, blocks with the same content have the same block identifier, but blocks with different content have different block identifiers. To achieve even distribution, the values of possible unique identifiers can have a uniform distribution. Accordingly, storing data blocks based upon the unique identifier, or a portion of the unique identifier, results in the data being stored substantially evenly across drives in the cluster.

Because client data, e.g., a volume associated with the client, is spread evenly across all of the drives in the cluster, every drive in the cluster is involved in the read and write paths of each volume. This configuration balances the data and load across all of the drives. This arrangement also removes hot spots within the cluster, which can occur when client's data is stored sequentially on any volume.

In addition, having data spread evenly across drives in the cluster allows a consistent total aggregate performance of a cluster to be defined and achieved. This aggregation can be achieved, since data for each client is spread evenly through the drives. Accordingly, a client's I/O will involve all the drives in the cluster. Since, all clients have their data spread substantially evenly through all the drives in the storage system, a performance of the system can be described in aggregate as a single number, e.g., the sum of performance of all the drives in the storage system.

6

Block servers **112** and slice servers **124** maintain a mapping between a block identifier and the location of the data block in a storage medium of block server **112**. A volume includes these unique and uniformly random identifiers, and so a volume's data is also evenly distributed throughout the cluster.

Metadata layer **104** stores metadata that maps between client layer **102** and block server layer **106**. For example, metadata servers **110** map between the client addressing used by clients **108** (e.g., file names, object names, block numbers, etc.) and block layer addressing (e.g., block identifiers) used in block server layer **106**. Clients **108** may perform access based on client addresses. However, as described above, block servers **112** store data based upon identifiers and do not store data based on client addresses. Accordingly, a client can access data using a client address which is eventually translated into the corresponding unique identifiers that reference the client's data in storage **116**.

Although the parts of system **100** are shown as being logically separate, entities may be combined in different fashions. For example, the functions of any of the layers may be combined into a single process or single machine (e.g., a computing device) and multiple functions or all functions may exist on one machine or across multiple machines. Also, when operating across multiple machines, the machines may communicate using a network interface, such as a local area network (LAN) or a wide area network (WAN). In one implementation, one or more metadata servers **110** may be combined with one or more block servers **112** in a single machine. Entities in system **100** may be virtualized entities. For example, multiple virtual block servers **112** may be included on a machine. Entities may also be included in a cluster, where computing resources of the cluster are virtualized such that the computing resources appear as a single entity.

FIG. 1B depicts a more detailed example of system **100** according to one implementation. Metadata layer **104** may include a redirector server **120** and multiple volume servers **122**. Each volume server **122** may be associated with a plurality of slice servers **124**.

In this example, client **108a** wants to connect to a volume (e.g., client address). Client **108a** communicates with redirector server **120**, identifies itself by an initiator name, and also indicates a volume by target name that client **108a** wants to connect to. Different volume servers **122** may be responsible for different volumes. In this case, redirector server **120** is used to redirect the client to a specific volume server **122**. To client **108**, redirector server **120** may represent a single point of contact. The first request from client **108a** then is redirected to a specific volume server **122**. For example, redirector server **120** may use a database of volumes to determine which volume server **122** is a primary volume server for the requested target name. The request from client **108a** is then directed to the specific volume server **122** causing client **108a** to connect directly to the specific volume server **122**. Communications between client **108a** and the specific volume server **122** may then proceed without redirector server **120**.

Volume server **122** performs functions as described with respect to metadata server **110**. Additionally, each volume server **122** includes a performance manager **114**. For each volume hosted by volume server **122**, a list of block identifiers is stored with one block identifier for each logical block on the volume. Each volume may be replicated between one or more volume servers **122** and the metadata for each volume may be synchronized between each of the

volume servers **122** hosting that volume. If volume server **122** fails, redirector server **120** may direct client **108** to an alternate volume server **122**.

In one implementation, the metadata being stored on volume server **122** may be too large for one volume server **122**. Thus, multiple slice servers **124** may be associated with each volume server **122**. The metadata may be divided into slices and a slice of metadata may be stored on each slice server **124**. When a request for a volume is received at volume server **122**, volume server **122** determines which slice server **124** contains metadata for that volume. Volume server **122** then routes the request to the appropriate slice server **124**. Accordingly, slice server **124** adds an additional layer of abstraction to volume server **122**.

The above structure allows storing of data evenly across the cluster of disks. For example, by storing data based on block identifiers, data can be evenly stored across drives of a cluster. As described above, data evenly stored across the cluster allows for performance metrics to manage load in system **100**. If the system **100** is under a load, clients can be throttled or locked out of a volume. When a client is locked out of a volume, metadata server **110** or volume server **122** may close the command window or reduce or zero the amount of read or write data that is being processed at a time for client **108**. The metadata server **110** or the volume server **122** can queue access requests for client **108**, such that IO requests from the client **108** can be processed after the client's access to the volume resumes after the lock out period.

Performance Metrics and Load of the Storage System

The storage system **100** can also include a performance manager **114** that can monitor clients' use of the storage system's resources. In addition, performance manager **114** can regulate the client's use of the storage system **100**. The client's use of the storage system can be adjusted based upon performance metrics, the client's quality of service parameters, and the load of the storage system. Performance metrics are various measurable attributes of the storage system. One or more performance metrics can be used to calculate a load of the system, which, as described in greater detail below, can be used to throttle clients of the system.

Performance metrics can be grouped in different categories of metrics. System metrics is one such category. System metrics are metrics that reflect the use of the system or components of the system by all clients. System metrics can include metrics associated with the entire storage system or with components within the storage system. For example, system metrics can be calculated at the system level, cluster level, node level, service level, or drive level. Space utilization is one example of a system metric. The cluster space utilization reflects how much space is available for a particular cluster, while the drive space utilization metric reflects how much space is available for a particular drive. Space utilization metrics can also be determined for at the system level, service level, and the node level. Other examples of system metrics include measured or aggregated metrics such as read latency, write latency, input/output operations per second (IOPS), read IOPS, write IOPS, I/O size, write cache capacity, dedupe-ability, compressibility, total bandwidth, read bandwidth, write bandwidth, read/write ratio, workload type, data content, data type, etc.

IOPS can be real input/output operations per second that are measured for a cluster or drive. Bandwidth may be the amount of data that is being transferred between clients **108** and the volume of data. Read latency can be the time taken for the system **100** to read data from a volume and return the data to a client. Write latency can be the time taken for the

system to write data and return a success indicator to the client. Workload type can indicate if IO access is sequential or random. The data type can identify the type of data being accessed/written, e.g., text, video, images, audio, etc. The write cache capacity refers to a write cache or a node, a block server, or a volume server. The write cache is relatively fast memory that is used to store data before it is written to storage **116**. As noted above, each of these metrics can be independently calculated for the system, a cluster, a node, etc. In addition, these values can also be calculated at a client level.

Client metrics are another category of metrics that can be calculated. Unlike system metrics, client metrics are calculated taking into account the client's use of the system. As described in greater detail below, a client metric may include use by other client's that are using common features of the system. Client metrics, however, will not include use of non-common features of the system by other clients. In one implementation, client metrics can include the same metrics as the system metrics, but rather than being component or system wide, are specific to a volume of the client. For example, metrics such as read latency or write IOPS can be monitored for a particular volume of a client.

Metrics, both system and client, can be calculated over a period of time, e.g., 250 ms, 500 ms, 1 s, etc. Accordingly, different values such as a min, max, standard deviation, average, etc., can be calculated for each metric. One or more of the metrics can be used to calculate a value that represents a load of the storage system. Loads can be calculated for the storage system as a whole, for individual components, for individual services, and/or individual clients. Load values, e.g., system load values and/or client load values, can then be used by the quality of service system to determine if and how clients should be throttled.

As described in greater detail below, performance for individual clients can be adjusted based upon the monitored metrics. For example, based on a number of factors, such as system metrics, client metrics, and client quality of service parameters, a number of IOPS that can be performed by a client **108** over a period of time may be managed. In one implementation, performance manager **114** regulates the number of IOPS that are performed by locking client **108** out of a volume for different amounts of time to manage how many IOPS can be performed by client **108**. For example, when client **108** is heavily restricted, client **108** may be locked out of accessing a volume for 450 milliseconds every 500 milliseconds and when client **108** is not heavily restricted, client **108** is blocked out of a volume every 50 milliseconds for every 500 milliseconds. The lockout effectively manages the number of IOPS that client **108** can perform every 500 milliseconds. Although examples using IOPS are described, other metrics may also be used, as will be described in more detail below.

The use of metrics to manage load in system **100** is possible because a client's effect on global cluster performance is predictable due to the evenness of distribution of data, and therefore, data load. For example, by locking out client **108** from accessing the cluster, the load in the cluster may be effectively managed. Because load is evenly distributed, reducing access to the client's volume reduces that client's load evenly across the cluster. However, conventional storage architectures where hot spots may occur result in unpredictable cluster performance. Thus, reducing access by a client may not alleviate the hot spots because the client may not be accessing the problem areas of the cluster. Because in the described embodiment, client loads are evenly distributed through the system, a global performance

pool can be calculated and individual client contributions to how the system is being used can also be calculated.

Client Quality of Service Parameters

In addition to system metrics and client metrics, client quality of service (QoS) parameters can be used to affect how a client uses the storage system. Unlike metrics, client QoS parameters are not measured values, but rather variables that can be set that define the desired QoS bounds for a client. Client QoS parameters can be set by an administrator or a client. In one implementation, client QoS parameters include minimum, maximum, and max burst values. Using IOPS as an example, a minimum IOPS value is a proportional amount of performance of a cluster for a client. Thus, the minimum IOPS is not a guarantee that the volume will always perform at this minimum IOPS value. When a volume is in an overload situation, the minimum IOPS value is the minimum number of IOPS that the system attempts to provide the client. However, based upon cluster performance, an individual client's IOPS may be lower or higher than the minimum value during an overload situation. In one implementation, the system **100** can be provisioned such that the sum of the minimum IOPS across all clients is such that the system **100** can sustain the minimum IOPS value for all clients at a given time. In this situation, each client should be able to perform at or above its minimum IOPS value. The system **100**, however, can also be provisioned such that the sum of the minimum IOPS across all clients is such that the system **100** cannot sustain the minimum IOPS for all clients. In this case, if the system becomes overloaded through the use of all clients, the client's realized IOPS can be less than the client's minimum IOPS value. In failure situations, the system may also throttle users such that their realized IOPS are less than their minimum IOPS value. A maximum IOPS parameter is the maximum sustained IOPS value over an extended period of time. The max burst IOPS parameter is the maximum IOPS value that a client can "burst" above the maximum IOPS parameter for a short period of time based upon credits. In one implementation, credits for a client are accrued when the client is operating under their respective maximum IOPS parameter. Accordingly, a client will only be able to use the system in accordance with their respective maximum IOPS and maximum burst IOPS parameters. For example, a single client will not be able to use the system's full resources, even if they are available, but rather, is bounded by their respective maximum IOPS and maximum burst IOPS parameters.

As noted above, client QoS parameters can be changed at any time by the client or an administrator. FIG. 2 depicts a user interface **200** for setting client QoS in accordance with one illustrative implementation. The user interface **200** can include inputs that are used to change various QoS parameters. For example, slide bars **202** and/or text boxes **204** can be used to adjust QoS parameters. As noted above in one implementation, client QoS parameters include a minimum IOPS, a maximum IOPS, and a maximum burst IOPS. Each of these parameters can be adjusted with inputs, e.g., slide bars and/or text boxes. In addition, the IOPS for different size IO operations can be shown. In the user interface **200**, the QoS parameters associated with 4 k sized IO operations are changed. When any performance parameter is changed, the corresponding IOPS for different sized IO operations are automatically adjusted. For example, when the burst parameter is changed, IOPS values **206** are automatically adjusted. Once the QoS parameters have been set, activating a save changes button **208** updates the client's QoS parameters. As described below, the target performance manager **402** can use the updated QoS parameters, such that the updated QoS

parameters take effect immediately. The updated QoS parameters take effect without requiring any user data to be moved in the system.

Performance Management

FIG. 3 depicts a simplified flowchart **300** of a method of performing performance management according to one implementation. Additional, fewer, or different operations of the method **300** may be performed, depending on the particular embodiment. The method **300** can be implemented on a computing device. In one implementation, the method **300** is encoded on a computer-readable medium that contains instructions that, when executed by a computing device, cause the computing device to perform operations of the method **300**.

At **302**, performance manager **114** determines a client load based on one or more performance metrics. For example, performance manager **114** may calculate a client's load based on different performance metrics, such as IOPS, bandwidth, and latency. The metrics may be historical metrics and/or current performance metrics. Historical performance may measure previous performance for an amount of time, such as the last week of performance metrics. Current performance may be real-time performance metrics. Using these performance metrics, e.g., system metrics and/or client metrics, a load value is calculated.

At **303**, performance manager **114** gathers information about health of the cluster. The health of the cluster may be information that can quantify performance of the cluster, such as a load value. The cluster health information may be gathered from different parts of system **100**, and may include health in many different aspects of system **100**, such as system metrics and/or client metrics. In addition, cluster health information can be calculated as a load value from the client and/or system metrics. The health information may not be cluster-wide, but may include information that is local to the volume server **122** that is performing the performance management. The cluster health may be affected; for example, if there is a cluster data rebuild occurring, total performance of the cluster may drop. Also, when data discarding, adding or removing of nodes, adding or removing of volumes, power failures, used space, or other events affecting performance are occurring, performance manager **114** gathers this information from the cluster.

At **304**, performance manager **114** determines a target performance value. For example, based on the load values and client quality of service parameters, a target performance value is determined. The target performance value may be based on different criteria, such as load values, client metrics, system metrics, and quality of service parameters. The target performance value is the value at which performance manager **114** would like client **108** to operate. For example, the target performance may be 110 IOPS.

At **306**, performance manager **114** adjusts the performance of client **108**. For example, the future client performance may be adjusted toward the target performance value. If IOPS are being measured as the performance metric, the number of IOPS a client **108** performs over a period of time may be adjusted to the target performance value. For example, latency can be introduced or removed to allow the number of IOPS that a client can perform to fluctuate. In one example, if the number of IOPS in the previous client performance is 80 and the target performance value is 110 IOPS, then the performance of the client is adjusted to allow client **108** to perform more IOPS such that the client's performance moves toward performing 110 IOPS.

Traditional provisioning systems attempt to achieve a quality of service by placing a client's data on a system that

should provide the client with the requested quality of service. A client requesting a change to their quality of service, therefore, can require that the client's data be moved from one system to another system. For example, a client that wants to greatly increase its quality of service may need to be moved to a more robust system to ensure the increased quality of service. Unlike the traditional provisioning systems, the performance manager can dynamically adjust quality of service for specific clients without moving the client's data to another cluster. Accordingly, quality of service for a client can be adjusted instantly, and a client can change QoS parameters without requiring manual intervention for those QoS parameters to take effect. This feature allows the client to schedule changes to their QoS parameters. For example, if a client performs backups on the first Sunday of every month from 2:00 am-4:00 am, they could have their QoS parameters automatically change just prior to the start of the backup and change back after the backup finishes. This aspect allows a client the flexibility to schedule changes to their QoS parameters based upon the client's need. As another example, the client can be presented with a turbo button. When selected, the turbo button increases the client's QoS parameters by some factor, e.g., 3, 4, 5, etc., or to some large amount. Clients could use this feature if their data needs were suddenly increased, such as when a client's website is experiencing a high number of visitors. The client could then unselect the turbo button to return to their original QoS parameters. Clients could be charged for how long they use the turbo button features. In another implementation, the turbo button remains in effect for a predetermined time before the client's original QoS parameters are reset.

In addition to the above examples, clients and/or administrators can set client QoS parameters based upon various conditions. In addition, as noted above client QoS parameters are not limited to IOPS. In different implementations, client QoS parameters can be bandwidth, latency, etc. According to different embodiments, the storage system may be configured or designed to allow service providers, clients, administrators and/or users, to selectively and dynamically configure and/or define different types of QoS and provisioning rules which, for example, may be based on various different combinations of QoS parameters and/or provisioning/QoS target types, as desired by a given user or client.

According to different embodiments, examples of client QoS parameters may include, but are not limited to, one or more of the following (or combinations there:

- IOPS;
- Bandwidth;
- Write Latency;
- Read Latency;
- Write buffer queue depth;
- I/O Size (e.g., amount of bytes accessed per second);
- I/O Type (e.g., Read I/Os, Write I/Os, etc.);
- Data Properties such as, for example, Workload Type (e.g., Sequential, Random); Dedupe-ability;
- Compressibility; Data Content; Data Type (e.g., text, video, images, audio, etc.); etc.

According to different embodiments, examples of various provisioning/QoS target types may include, but are not limited to, one or more of the following (or combinations thereof):

- Service or group of Services;
- Client or group of Clients;
- Connection (e.g. Client connection);
- Volume, or group of volumes;
- Node or group of nodes;

- Account/Client;
- User;
- iSCSI Session;
- Time segment;
- Read IOPS amount;
- Write IOPS amount;
- Application Type;
- Application Priority;
- Region of Volume (e.g., Subset of LBAs);
- Volume Session(s);
- I/O size;
- Data Property type;
- etc.

FIG. 8 shows an example QoS Interface GUI 800 which may be configured or designed to enable service providers, users, and/or other entities to dynamically define and/or create different performance classes of use and/or to define performance/QoS related customizations in the storage system. In at least one embodiment, the QoS Interface GUI 800 may be configured or designed to allow service providers, users, and/or other entities dynamically switch between the different performance classes of use, allowing such clients to dynamically change their performance settings on the fly (e.g., in real-time).

For example, according to various embodiments, a service provider may dynamically define and/or create different performance classes of use in the storage system, may allow clients to dynamically switch between the different performance classes of use, allowing such clients to dynamically modify or change their performance settings on the fly (e.g., in real-time). In at least one embodiment, the storage system is configured or designed to immediately implement the specified changes for the specified provisioning/QoS Targets, and without requiring the client's storage volume to be taken off-line to implement the performance/QoS modifications. In at least one embodiment, the different performance classes of use may each have associated therewith a respective set of QoS and/or provisioning rules (e.g., 810) which, for example, may be based on various different combinations of QoS parameters and/or provisioning/QoS target types.

In the context of the present example, the respective set of QoS and/or provisioning rules 810 include an "IF" portion 820 and a "THEN" portion 840. The "IF" portion 820 includes a first conditional expression 88 and a second conditional expression 823 connected by a Boolean operator B 825. The first conditional expression 88 includes a boundary condition A 824, an operator A 826, and a threshold value A 828. The plus symbol 823 may be selected to add additional conditional expressions. When the one or more conditional expressions of the "IF" portion 820 evaluate to true, the "THEN" portion is performed. The "THEN" portion 840 includes a first performance setting 841 and a second performance setting 843 connected by a Boolean operator D 845. The first performance setting 841 includes a QoS parameter type C 842 that is to be set for provisioning/QoS target C 844 based on operator C 846 to a threshold value C 848. The plus symbol 847 may be selected to add additional performance settings.

The above process for performing performance management may be performed continuously over periods of time. For example, a period of 500 milliseconds is used to evaluate whether performance should be adjusted. As will be described in more detail below, client 108 may be locked out of performing IOPS for a certain amount of time each period to reduce or increase the number of IOPS being performed.

13

Examples of different types of conditions, criteria and/or other information which may be used to configure the QoS Interface GUI of FIG. 8 may include, but are not limited to, one or more of the following (or combinations thereof):

Example Boundary Conditions (e.g., 824)

LOAD(Service);	Date
LOAD(Read);	Read IOPS
LOAD(Write);	Write IOPS
LOAD(Write_Buffer);	Application Type
LOAD(Client-Read);	Application Priority
LOAD(Client-Write);	Region of Volume
LOAD(Client);	LBA ID
LOAD(Cluster);	Volume Session ID
LOAD(System)	Connection ID
Write Latency;	I/O size
Read Latency;	I/O Type
Write buffer queue depth;	Workload Type
LOAD(Client);	Dedupe-ability
Volume ID	Compressability
Group ID	Data Content
Account ID	Data Type
Client ID	Data Properties
User ID	Detectable Condition and/or Event
iSCSI Session ID	Etc.
Time	

Example QoS Parameters (e.g., 842)

MAX IOPS	MAX Read I/O
MIN IOPS	MIN Read I/O
BURST IOPS	BURST Read I/O
MAX Bandwidth	MAX Write I/O
MIN Bandwidth	MIN Write I/O
BURST Bandwidth	BURST Write I/O
MAX Latency	I/O Type
MIN Latency	Workload Type
BURST Latency	Dedupe-ability
MAX I/O Size	Compressability
MIN I/O Size	Data Content
BURST I/O Size	Data Type
I/O Type	Billing Amount

Example Provisioning/QoS Targets (e.g., 844)

Cluster ID	Application Type
Service ID	Application Priority
Client ID	Region of Volume
Connection ID	LBA ID
Node ID	Volume Session ID
Volume ID	Connection ID
Group ID	I/O size
Account ID	I/O Type
Client ID	Workload Type
User ID	Dedupe-ability
iSCSI Session ID	Compressability
Time	Data Content
Date	Data Type
Read IOPS	Data Properties
Write IOPS	Etc.

Example Operators (e.g., 826, 846)

Equal To	Not Equal To
Less Than	Contains
Greater Than	Does Not Contain
Less Than or Equal To	Matches
Greater Than or Equal To	Regular Expression(s)
Within Range of	

14

Example Threshold Values (e.g., 828, 848)

Alpha-numeric value(s)	Random Type
Numeric value(s)	Text Type
Numeric Range(s)	Video Type
Numeric value per Time Interval value (e.g., 5000 IOPS/sec)	Audio Type
Sequential Type	Image Type
	Performance Class of Use Value

Example Boolean Operators (e.g., 825, 845)

	AND	NAND
	OR	NOR
	XOR	XNOR
	NOT	
	EXCEPT	

The following example scenarios help to illustrate the various features and functionalities enabled by the QoS Interface GUI 800, and help to illustrate the performance/QoS related provisioning features of the storage system:

Example A—Configuring/provisioning the storage system to automatically and/or dynamically increase storage performance to enable a backup to go faster during a specified window of time. For example, in one embodiment, the speed of a volume backup operation may be automatically and dynamically increased during a specified time interval by causing a MAX IOPS value and/or MIN IOPS value to be automatically and dynamically increased during that particular time interval.

Example B—Configuring/provisioning the storage system to automatically and/or dynamically enable a selected initiator to perform faster sequential I/Os from 10 pm to Midnight.

Example C—Configuring/provisioning the storage system to automatically and/or dynamically enable a selected application to have increased I/O storage performance.

Example D—Configuring/provisioning the storage system to automatically and/or dynamically enable a selected group of clients to have their respective MAX, MIN and BURST IOPS double on selected days/dates of each month.

Example E—Configuring/provisioning the storage system to present a client or user with a “Turbo Boost” interface which includes a virtual Turbo Button. Client may elect to manually activate the Turbo Button (e.g., on the fly or in real-time) to thereby cause the storage system to automatically and dynamically increase the level of performance provisioned for that Client. For example, in one embodiment, client activation of the Turbo Button may cause the storage system to automatically and dynamically increase the client’s provisioned performance by a factor of 3x for one hour. In at least one embodiment, the dynamic increase in provisioned performance may automatically cease after a predetermined time interval. In at least one embodiment, the storage system may be configured or designed to charge the client an increased billing amount for use of the Turbo Boost service/feature.

Example F—Configuring/provisioning the storage system to automatically and/or dynamically charge an additional fee or billing amount for dynamically providing increased storage array performance (e.g., to allow a faster backup) to go faster at a particular time.

Example G—Configuring/provisioning the storage system to automatically and/or dynamically charge an additional fee or billing amount for IOPS and/or I/O access of the storage system which exceeds minimum threshold value(s) during one or more designated time intervals.

Performance manager **114** may use different ways of adjusting performance FIG. 4 depicts a more detailed example of adjusting performance using performance manager **114** according to one implementation. A target performance manager **402** determines a target performance value. In one implementation, target performance manager **402** uses the client's QoS parameters, system metrics, and client metrics to determine the target performance value. System metrics and client metrics can be used to determine the system load and client load. As an example, client load can be measured based on a client metrics, such as in IOPS, bytes, or latency in milliseconds.

In one implementation, system metrics are data that quantifies the current load of the cluster. Various system load values can be calculated based upon the system metrics. The load values can be normalized measures of system load. For example, different load values can be compared to one another, even if the load values use different metrics in their calculations. As an example, system load can be expressed in a percentage based on the current load of the cluster. In one example, a cluster that is overloaded with processing requests may have a lower value than when the system is not overloaded. In another implementation, the target performance manager **402** receives calculated load values as input, rather than system and/or client metrics.

The target performance manager **402** can read the client QoS parameters, relevant system metrics, and relevant client metrics. These values can be used to determine the target performance value for client **108**. The QoS parameters may also be dynamically adjusted during runtime by the administrator or the client as described above, such as when a higher level of performance is desired (e.g., the customer paid for a higher level of performance). The calculation of the target performance value is explained in greater detail below.

In one implementation, the target performance manager **402** outputs the target performance value to a proportion-integral-derivative (PID) controller block **404**. PID controller block **404** may include a number of PID controllers for different performance metrics. Although PID controllers are described, other controllers may be used to control the performance of clients **108**. In one example, PID controller block **404** includes PID controllers for IOPS, bandwidth, and latency. Target performance manager **402** outputs different target performance values for the performance metrics into the applicable PID controllers. The PID controllers also receive information about previous and/or current client performance and the target performance value. For example, the PID controllers can receive client metrics, system metrics, and/or load values, that correspond with the target performance value. The PID controller can then determine a client performance adjustment value. For example, a PID controller is configured to take feedback of previous client performance and determine a value to cause a system to move toward the target performance value. For example, a PID can cause varied amounts of pressure to be applied, where pressure in this case causes client **108** to slow down, speed up or stay the same in performing IOPS. As an example, if the target performance value is 110 IOPS and client **108** has been operating at 90 IOPS, then the client performance adjustment value is output, which by being applied to the client **108** should increase the number of IOPS being performed.

In one implementation, PID controller block **404** outputs a performance adjustment value. As an example, the performance adjustment value can be a pressure value that indicates an amount of time that the client is locked out

performing IO operations within the storage system. This lock out time will cause client performance to move toward the target performance value. For example, a time in milliseconds is output that is used to determine how long to lock a client **108** out of a volume. Locking a client out of performing IO operations artificially injects latency into the client's IO operations. In another of implementations, the performance adjustment value can be a number of IO operations that the client can perform in a period of time. If the client attempts to do more IO operations, the client can be locked out of doing those IO operations until a subsequent period of time. Locking client **108** out of the volume for different times changes the number of IOPS performed by client **108**. For example, locking client **108** out of the volume for shorter periods of time increases the number of IOPS that can be performed by client **108** during that period.

A performance controller **406** receives the performance adjustment value and outputs a client control signal to control the performance of client **108**. For example, the amount of lockout may be calculated and applied every half second. In one implementation, clients **108** are locked out by closing and opening a command window, such as an Internet small computer system interface (iSCSI) command window. Closing the command window does not allow a client **108** to issue access requests to a volume and opening the command window allows a client **108** to issue access requests to the volume. Locking clients **108** out of a volume may adjust the number of IOPS, bandwidth, or latency for client **108**. For example, if a client **108** is locked out of a volume every 50 milliseconds of every 500 milliseconds as compared to being locked out of the volume for 450 milliseconds of every 500 milliseconds, the client may issue more IOPS. For a bandwidth example, if bandwidth is constrained, then client **108** is locked out of a volume for a longer period of time to increase available bandwidth. In another implementation, the amount of data that is being serviced at a time is modified, either to zero or some number, to affect the performance at which the system services that client's IO.

As described above, IOPS are metrics that can be used to manage performance of a client. IOPS include both write IOPS and read IOPS. Individual input/output operations do not have a set size. That is, an input operation can be writing 64 k of data to a drive, while another input operation can be writing 4 k of data to the drive. Accordingly, capturing the raw number of input/output operations over a period of time does not necessarily capture how expensive the IO operation actually is. To account for this situation, an input/output operation can be normalized based upon the size of the I/O operation. This feature allows for consistent treatment of IOPS, regardless of each operation's size of the data. This normalization can be achieved using a performance curve. FIG. 5 depicts a performance curve **500** comparing the size of input/output operations, with system load in accordance with an illustrative implementation. Line **504** indicates the system at full load, while line **502** indicates the load of the system for 10 operations of differing sizes. The performance curve can be determined based upon empirical data of the system **100**. The performance curve allows IOPS of different sizes to be compared and to normalize IOPS of different sizes. For example, an IOP of size 32 k is roughly five times more costly than a 4 k IOP. That is, the number of IOPS of size 32 k to achieve 100% load of a system is roughly 20% of the number of IOPS of size 4 k. This is because larger block sizes have a discount of doing IP and not having to process smaller blocks of data. In various implementations, this curve can be used as a factor in deciding a client's target performance value. For example, if the target performance

value for a client is determined to be 1,000 IOPS, this number can be changed based upon the average size of IOs the client has done in the past. As an example, if a client's average IO size is 4 k, the client's target performance value can remain at 1,000 IOPS. However, if the client's average IO size is determined to be 32 k, the client's target performance value can be reduced to 200 IOPS, e.g., $1,000 \times 0.2$. The 200 IOPS of size 32 k is roughly equivalent to 1,000 IOPS of size 4 k.

In determining a target performance value, the target performance manager 402 uses a client's QoS parameters to determine the target performance value for a client. In one implementation, an overload condition is detected and all clients are throttled in a consistent manner. For example, if the system load is determined to be at 20%, all clients may be throttled such that their target performance value is set to 90% of their maximum IOPS setting. If the system load increases to 50%, all clients can be throttled based upon setting their target performance value to 40% of their maximum IOPS setting.

Clients do not have to be throttled in a similar manner. For example, clients can belong to different classes of uses. In one implementation, classes of uses can be implemented simply by setting the QoS parameters of different clients differently. For example, a premium class of use could have higher QoS parameters, e.g., min IOPS, max IOPS, and burst IOPS, values compared to a normal class of use. In another implementation, the class of use can be taken into account when calculating the target performance value. For example, taking two different classes, one class could be throttled less than the other class. Using the example scenario above, clients belonging to the first class could be throttled 80% of their maximum IOPS value when the system load reaches 20%. The second class of clients, however, may not be throttled at all or by a different amount, such as 95% of their maximum IOPS value.

In another implementation, the difference between a client's minimum IOPS and maximum IOPS can be used to determine how much to throttle a particular client. For example, a client with a large difference can be throttled more than a client whose difference is small. In one implementation, the difference between the client's maximum IOPS and minimum IOPS is used to calculate a factor that is applied to calculate the target performance value. In this implementation, the factor can be determined as the IOPS difference divided by some predetermined IOPS amount, such as 5,000 IOPS. In this example, a client whose difference between their maximum IOPS and their minimum IOPS was 10,000, would be throttled twice as much as a client whose IOPS difference was 5,000. Clients of the system can be billed different amounts based upon their class. Accordingly, clients could pay more to be throttled later and/or less than other classes of clients.

In another implementation, throttling of clients can be based upon the client's use of the system. In this implementation, the target performance manager 402 can review system metrics to determine what metrics are currently overloaded. Next, the client metrics can be analyzed to determine if that client is contributing to an overloaded system value. For example, the target performance manager 402 can determine that the system is overloaded when the cluster's write latency is overloaded. The read/write IOPS ratio for a client can be used to determine if a particular client is having a greater impact on the overload condition. Continuing this example, a client whose read/write IOPS ratio was such that the client, was doing three times more writes than reads and was doing 1,500 writes would be

determined to be negatively impacting the performance of the cluster. Accordingly, the target performance manager 402 could significantly throttle this client. In one implementation, this feature can be done by calculating a factor based upon the read/write IOPS ratio. This factor could be applied when calculating the target performance value, such that the example client above would be throttled more than a client whose read/write IOPS ratio was high. In this example, a high read/write IOPS ratio indicates that the client is doing more reads than writes. The factor can also be based upon the number of IOPS that each client is doing. In addition, the number of IOPS for a particular client can be compared to the number of IOPS for the cluster, such that an indication of how heavily a particular client is using the cluster can be determined. Using this information, the target performance manager can calculate another factor than can be used to scale the target performance value based upon how much a client is using the system compared to all other clients.

FIG. 6 depicts a simplified flowchart of a method 600 of performing performance management that matches an overloaded system metric with a client metric in accordance with one illustrative implementation. Additional, fewer, or different operations of the method 600 may be performed, depending on the particular embodiment. The method 600 can be implemented on a computing device. In one implementation, the method 600 is encoded on a computer-readable medium that contains instructions that, when executed by a computing device, cause the computing device to perform operations of the method 600.

In an operation 602, client metrics can be determined. For example, a performance manager 114 can determine client metrics, as described above, for a preceding period of time, e.g., 100 ms, 1 s, 10 s, etc. In an operation 604, system metrics can be determined. For example, the performance manager 114 or another process can determine system metrics as described above. In one implementation, the client metrics and/or system metrics are used to calculate one or more load values. In an operation 606, the target performance manager 402 can then determine if the system is overloaded in way based upon various load values. For example, the target performance manager 402 can determine if a system is overloaded by comparing system load values with corresponding thresholds. Any load value above its corresponding threshold indicates an overload condition. In one implementation, the system load values are analyzed in a prioritized order and the first overloaded load value is used to determine how to throttle clients.

In an operation 608, one or more corresponding client metrics associated with the overloaded load value are determined. For example, if the overloaded system load is the number of read operations, the client's number of read operations can be used as the associated client metric. The client's metric does not have to be the same as the overloaded system metric. As another example, if the overloaded system load is read latency, the corresponding client metrics can be the ratio of read to write IO operations and the total number of read operations for a client. In an operation 610, a client-specific factor is determined based upon the client metric associated with the overloaded system load value. In the first example above, the factor can be the number of the client's read operations divided by the total number of read operations of the cluster. The client factor, therefore, would be relative to how much the client is contributing to the system load value. Clients that were doing a relatively larger number of reads would have a greater client metric compared with a client that was doing a relatively smaller number of reads.

In an operation **612**, the client-specific factor is used to calculate the target performance value for the client. In one implementation, an initial target performance value can be calculated and then multiplied by the client specific factor. In another implementation, a cluster reduction value is determined and this value is multiplied by the client specific factor. Continuing the example above, the cluster reduction value can be the number of read IOPS that should be throttled. Compared to throttling each client equally based upon the cluster reduction value, using the client-specific factor results in the same number of read IOPS that are throttled, but clients who have a large number of read IO operations are throttled more than clients who have a smaller number of read IO operations. Using client-specific factors helps the target performance manager **402** control the throttling of clients to help ensure that the throttling is effective. For example, if client-specific factors were not used and throttling was applied equally across all clients, a client whose use of the system was not contributing to the system's overloading would be unnecessarily throttled. Worse, the throttling of all of the clients might not be as effective since the throttling of clients who did not need to be throttled would not help ease the overloading condition, which could result in even more throttling being applied to clients.

In an operation **614**, the performance manager **114** can adjust the performance of client **108**. For example, the client's use of the system can be throttled as described above.

Using the above system, clients **108** may be offered performance guarantees based on performance metrics, such as IOPS. For example, given that system **100** can process a total number of IOPS, the total number may be divided among different clients **108** in terms of a number of IOPS within the total amount. The IOPS are allocated using the min, max, and burst. If it is more than the total then possible, the administrator is notified that too many IOPS are being guaranteed and instructed to either add more performance capacity or change the IOP guarantees. This notification may be before a capacity threshold is reached (e.g., full capacity or a pre-defined threshold below full capacity). The notification can be sent before the capacity is reached because client performance is characterized in terms of IOPS and the administrator can be alerted that performance is overprovisioned by N number of IOPS. For example, clients **108** may be guaranteed to be operating between a minimum and maximum number of IOPS over time (with bursts above the maximum at certain times). Performance manager **114** can guarantee performance within these QoS parameters using the above system. Because load is evenly distributed, hot spots will not occur and system **100** may operate around the total amount of IOPS regularly. Thus, without hot spot problems and with system **100** being able to provide the total amount of IOPS regularly, performance may be guaranteed for clients **108** as the number of IOPS performed by clients **108** are adjusted within the total to make sure each client is operating within the QoS parameters for each given client **108**. Since each client's effect on a global pool of performance is measured and predictable, the administrator can consider the entire cluster's performance as a pool of performance as opposed to individual nodes, each with its own performance limits. This feature allows the cluster to accurately characterize its performance and guarantee its ability to deliver performance among all of its volumes.

Accordingly, performance management is provided based on the distributed data architecture. Because data is evenly distributed across all drives in the cluster, the load of each individual volume is also equal across every single drive in

storage system **100**. This feature may remove hot spots and allow performance management to be accurate and fairly provisioned and to guarantee an entire cluster performance for individual volumes.

5 Independent Control of Write IOPS and Read IOPS

In some systems, read and write IOPS are combined and can be controlled at a system level. For example, a storage system can throttle the number of IOPS that are run within a given time period. These systems, therefore, assume that a read and a write IOP are similar in regards to the cost to perform each IOP. Generally, a write IOP is more expensive to complete compared to a read IOP. For example, a write IOP can include both reading and writing metadata compared to a read IOP that can avoid any metadata writes. Treating write IOPS separately from read IOPS at a system level allows for a system to fine tune system performance. In one example, an overloaded system can throttle writes to help reduce the overloading but allow reads to continue without throttling. This can allow for users of the storage system who are doing mostly reads to see less slowdown compared to a system that would throttle read and write IOPS together.

FIG. 7A illustrates an example allocation of IOPS **700** to a client over a period of time t . In particular, the FIG. 7A shows an allocation of total IOPS **702**, read IOPS **704**, and write IOPS **706** to a client over a time period t . The client, such as a client **108** shown in FIGS. 1A and 1B, is allocated 100 total IOPS **702**. Of the allocated 100 IOPS, the client is allocated a maximum of 75 read IOPS **704** and a maximum of 50 write IOPS **706**. That is, even though the client is allocated 100 total IOPS, the IOPS cannot exceed 50 write IOPS and cannot exceed 75 read IOPS. The client can request a combination of a number of write IOPS and a number of read IOPS that satisfy the allocation shown in FIG. 7A. It is understood that the number of total IOPS **702**, the read IOPS **704**, and the write IOPS **706** can have values different than the ones shown in FIG. 7A, however, the number of read IOPS **704** and the number of write IOPS **706** may not exceed the total number of IOPS **702**. For example, in one or more embodiments, the number of read IOPS **704** can be equal to the total number of IOPS **702**. As noted above, write IOPS are typically more expensive, in terms of system resources, than read IOPS. Reading and writing of metadata, write access times, etc. are some reasons why writes are more expensive compared to reads. Thus, the system may allow the user to request as many read IOPS as the total IOPS allocated, but limit the number of write IOPS to a number that is substantially smaller than the total IOPS.

The allocation of IOPS **700** is defined over a time period t . The time period t can represent the duration of time over which the QoS parameter for the client is defined. For example, without limitation, the time period t can be equal to about 10 ms to about 1 s.

In one or more embodiments, the allocation of total IOPS **702** shown in FIG. 7A can represent client maximum QoS parameters, such as the maximum IOPS discussed above in relation to FIG. 2. An administrator, for example, can use the user interface **200** shown in FIG. 2 to adjust the total IOPS by adjusting the maximum QoS value using sliders **202**. In one or more embodiments, the user interface **200** can also display maximum read IOPS and maximum write IOPS values to the user, and provide the ability to change these values. For example, the user interface can include two additional columns one each for maximum read IOPS and maximum write IOPS. The columns can include rows of IOPS corresponding to each of the various IO sizes, such as 4 KB, 8 KB, 16 KB, and 256 KB. The user interface **200** can

additionally include sliders **202** or text boxes to allow setting and changing the values of the total IOPS, read IOPS and write IOPS, in a manner similar to that discussed above in relation to altering the values of minimum IOPS, maximum IOPS, and burst IOPS in FIG. 2.

In one or more embodiments, the allocation of IOPS **700** can be determined by a performance manager, such as the performance manager **114** discussed above in relation to FIG. 1B. In particular, the performance manager **114** can determine the allocation of IOPS **700** based on the result of determining target performance values for the client **108**. As discussed above, the performance manager **114** can determine target performance values associated with a client **108** based at least on a load value and client quality of service parameters. The load value can quantify the health of a cluster of storage drives **116** accessed by the clients **108**. For example, the load value can refer to the total number of IOPS a cluster of storage drives **116** is receiving and/or processing from one or more clients **108**. The client quality of service parameters can refer to the bandwidth allocated to the client **108**. In one or more embodiments, the client quality of service parameters can refer to the number of IOPS per unit time promised to a client **108**. In one or more embodiments, the performance manager **114** can compare the load value to the client's quality of service parameters, and adjust the target performance values, such as the total IOPS, read IOPS and the write IOPS, such that the load value associated with the cluster of storage drives **116** is maintained at acceptable levels.

In one or more embodiments, the allocation of IOPS **700** shown in FIG. 7A can change over time based on the system and client metrics received by the performance manager **114**. For example, if the performance manager **114** determines that it has oversubscribed the available IOPS on the system, the performance manager **114** may dynamically alter the allocation of IOPS such that the available IOPS are appropriately distributed among clients **108**. In one or more embodiments, each client **108** can have a different allocation of IOPS based on the quality of service agreement with that client.

FIG. 7B shows an example flow diagram of a process **730** for independent control of read IOPS and write IOPS associated with a client. In particular, the process **730** can be executed by the performance manager **114** discussed above in relation to FIG. 1A. In one or more embodiments, the target performance manager **402** shown in FIG. 4 can be used to execute the process **730** to generate a set of client target performance values. In some such embodiments, the target performance values generated by the target performance manager **402** can be directly fed to the performance controller **406** without being modified by the PID controller block **404**. FIG. 7C shows example target IOPS **750** associated with a client over a time period t . In particular, the target IOPS **750** illustrate a result of the execution of the process **730** shown in FIG. 7B, which result includes target total IOPS **902**, target read IOPS **904**, and target write IOPS **906**. The process **730** shown in FIG. 7B is discussed in detail below in conjunction with the allocated IOPS **700** shown in FIG. 7A and the target IOPS **750** shown in FIG. 7C.

In some embodiments, after the client target performance values are calculated for a client, the process **730** includes, for a first time period, allocating write IOPS, read IOPS, and total IOPS for a client (operation **732**). As discussed above in relation to FIG. 7A, the client can be allocated a given number of total IOPS, read IOPS and write IOPS. Specifically, FIG. 7A shows an example in which the client is allocated 100 total IOPS, 75 read IOPS, and 50 write IOPS.

The process **730** also includes receiving write IOPS request from the client for the first time period (operation **734**). As discussed above in relation to FIGS. 1A and 1B, a client **108** can request writing to client data stored in the storage **116**. Typically, the client **108** will issue a write request to the metadata server **110**, where the request can include the data to be written along with addressing information including, for example, the file name, the object name, or the block number, associated with client data stored in the storage **116**. The metadata server **110** can translate the client addressing information into block layer addressing that can be understood by the block server **112** associated with the storage **116**. The metadata server **110** also can determine the number of IOPS needed to write the client data into the storage. The number of IOPS can be determined based on, for example, the size of the IOPS handled by the block server **112**. In one or more embodiments, the number of IOPS for a given client data to be written in the storage **116** is an inverse function of the size of the IOPS handled by the block server **112**. The example in FIG. 9 assumes that the number of requested write IOPS corresponding to the requested client data write is equal to 100 write IOPS. It is understood that number of write IOPS can be different in other cases.

The process **730** further includes determining the lesser of the requested write IOPS and the allocated write IOPS (operation **736**). This operation compares the number of requested IOPS to the number of allocated write IOPS. For example, as shown in FIG. 7C, the number of requested write IOPS (100) is greater than the number of allocated write IOPS (50). Thus, the allocated write IOPS is the lesser of the number of requested write IOPS and the number of allocated write IOPS. Further, the target write IOPS **756** is equated to the lesser of the requested write IOPS and the allocated write IOPS, that is, the allocated write IOPS (50). Of course, if the requested write IOPS were less than the allocated write IOPS (for example, if the requested number of write IOPS were 40 and the allocated write IOPS were 50), then the number of requested write IOPS would be the lesser of the number of requested write IOPS and the number of allocated write IOPS. Therefore, the number of target write IOPS **756** would be set to the number of requested write IOPS (40). It is noted that while the number of requested write IOPS of 100 is equal to the total number of allocated IOPS of 100, the allocation of only 50 write IOPS precludes the client from receiving more than 50 write IOPS for that particular time period t .

The process **730** also includes subtracting the lesser of the requested write IOPS and the allocated write IOPS from the allocated total IOPS (operation **738**). In other words, the number of target write IOPS are subtracted from the number of allocated total IOPS. As shown in FIG. 7C, the 50 target write IOPS **756** are subtracted from the 100 allocated total IOPS to result in the target total IOPS **752** of 50. The target total IOPS **752** is indicated by the shaded region between 100 and 50.

The process further includes determining a number of deferred write IOPS (operation **740**). The number of deferred write IOPS is determined by determining the difference between the number of requested write IOPS and the number of target write IOPS. For example, referring to FIG. 7C, the number of target write IOPS is indicated by the first shaded region **756**. Subtracting the number of requested write IOPS (100) from the target write IOPS (50) **756** results in a negative number: -50 . The absolute (50) of the resulting number (-50) indicates the number of deferred write IOPS **758**. These deferred write IOPS indicate the number of write

IOPS that are to be handled in a subsequent time period (operation 742). For example, the deferred write IOPS can be executed in a subsequent time period in a manner similar to that discussed above in relation to the requested write IOPS. Thus, if the number of allocated write IOPS in a subsequent time period is same (50) as that shown in FIG. 7A, then the deferred write IOPS can be executed in that subsequent time period. The management processor 114 may also take into account newly requested write IOPS during that subsequent time period to determine the target total and write IOPS.

It is noted that if the number of requested write IOPS is less than the number of allocated write IOPS, then there will be no deferred write IOPS. For example, if the number of number of requested write IOPS were 40, instead of 100, then the number of target write IOPS would be equal to 40, which can be accommodated by the number (50) of allocated write IOPS.

The resulting number of target total IOPS (50) leaves an additional number (50) of allocated IOPS that can be utilized by any read IOPS requested by the client. Thus, if the client 108 requests 50 read IOPS during the time period t, because the requested 50 read IOPS can be accommodated by both the allocated read IOPS (75) and the remaining allocated total IOPS (50), the requested read IOPS can be executed. It is noted that in some embodiments, the performance manager 114 may be configured to execute the requested write IOPS even if the number of requested write IOPS is greater than the number of allocated write IOPS as long as the number is less than or equal to the number of allocated total IOPS. For example, referring again to the above discussed example of receiving 100 requested write IOPS, as this number is equal to the 100 allocated total IOPS, the management processor 114 may set the target write IOPS to the requested write IOPS. In such instances, the number of allocated total IOPS would be completely exhausted for the time period t. As a result, any read IOPS requested by the client during the time period t would be denied by the management processor 114. The process 730 discussed above allows the management processor 114 to leave room for execution of read IOPS irrespective of the number of requested write IOPS.

The independent control of reads and writes can also be used when a storage system reaches a certain amount of free space. When the storage system reaches a critical level of free space, e.g., 5%, 10%, 12% of free system space and/or drive space, the system can throttle all client writes by lowering the write IOPS for the system. Such action will slow down the number of writes to the system that will further decrease the amount of free space. This allows for data to be moved off of the cluster and/or drive. In one embodiment, when this condition occurs a new cluster for one or more volumes is selected. The data from the one or more volumes are moved from the current cluster/drive and moved to the new cluster. To help facilitate this, the read IOPS of the original system can be set high to ensure that reads of the data are allowed and the write IOPS of the new cluster can be set to high at both the system level and the client level to ensure that the writes to the new cluster are not throttled. Once the data is moved to the new system, the data be deleted from the original system to free up space. In some embodiments, deletion of data can be either a write operation or considered a metadata only operation.

In various embodiments, metadata IO can be controlled independently of data 10. In one or more embodiments, the process 730 discussed above can be carried out in conjunction with the system level performance management, as

discussed above in relation to the method 600 shown in FIG. 6. In particular, the performance manager 114 can throttle the allocation of the total number of IOPS based on the current performance of the system, but allocate the read IOPS 704 and write IOPS 706 independently of the allocation of the total number of IOPS. In this manner, the performance manager 114 can throttle the allocation of the total number of IOPS 702 based on the system performance, as discussed in the method shown in FIG. 6, and in addition determine the target write IOPS 756 and deferred IOPS 758 based on the process 730 shown in FIG. 7B. In some other embodiments, the total IOPS, the read IOPS, and the write IOPS may all be throttled independently of each other based on the current performance of the system.

While the allocation of IOPS 700 shown in FIG. 7A is associated with the data associated with the client, the performance manager 114 also can maintain an allocation of IOPS for metadata access IO, including both reads and writes, or separate allocations for metadata reads and metadata writes. As discussed above in relation to FIGS. 1A and 1B, the metadata layer 104 can include metadata servers 110 or in some embodiments can include volume servers 114. The metadata servers 110 and the volume servers 114 translate the addressing scheme used by the client 108 into corresponding block server layer addressing scheme associated with the block server layer 106. The metadata servers 110 and the volume servers 114 can maintain mapping information that map the client addressing scheme to the block layer addressing scheme. The mapping information is typically stored as metadata in the metadata servers 110 or the volume servers 114. In one or more embodiments, the metadata can be stored in centralized storage, which can be accessed by one or more metadata servers 110 or volume servers 114 within the metadata layer 104. Accessing the metadata can include reading and writing. In one or more embodiments, the size of the metadata, and the number of IOPS associated with the read/write transactions between the metadata server 110 and metadata storage can be very large. In one or more such embodiments, the performance of the system can be impacted by not only the read and write IOPS associated with client data, but also due to the reads and write IOPS associated with the metadata.

In one or more embodiments, total, read, and write IOPS can be allocated to the metadata servers 110 or volume servers 114 for accessing metadata in a manner similar to that discussed above in relation to accessing client data. For example, a metadata performance manager, similar to the performance manager 114, can be used to manage system performance based on the metadata IOPS. The metadata performance manager can allocate total IOPS, read IOPS, and write IOPS for a metadata server 110 or a volume server 114. The metadata performance server can receive requested read and write IOPS from the metadata server 110 or the volume server 114 just as the performance manager 114 received read and write IOPS requests from clients. In a manner similar to the process 730 discussed above in relation to the performance manager 114, the metadata performance manager also can determine target read IOPS, target write IOPS and target total IOPS associated with metadata access. For example, the metadata performance manager can limit the number of target metadata write IOPS from exceeding the total metadata IOPS within a time period such that there are at least some room for executing any received metadata read IOPS during the same time period. The metadata performance manager can further determine deferred metadata write IOPS in cases where the requested metadata write IOPS exceeds the allocated metadata write

IOPS in a manner similar to that discussed above in relation to client data write IOPS in FIGS. 7A-7C.

In one or more embodiments, the metadata performance manager can dynamically change the allocated total, read, and write IOPS based on the system performance. In one or more embodiments, the metadata performance manager can receive system metrics as well as metadata metrics (such as, for example, metadata read/write IOPS, metadata storage capacity, or bandwidth) as inputs to determine the current load of the system and based on the determined current load and the system reallocate the total, read, and write IOPS. As one example, metadata access can be increased during certain system level operations, such as moving one or more volumes to another cluster or storage device.

Load Value Calculations

Load values can be used to determine if a client should be throttled to help ensure QoS among all clients. Various load values can be calculated based upon one or more system metric and/or client metric. As an example, a load value can be calculated that corresponds to a client's data read latency. When calculating a load value that corresponds with a client, how the client's data is managed on the storage system becomes important.

FIG. 9 shows a portion of a storage system in accordance with one illustrative implementation. In the specific example embodiment of FIG. 9, the storage system is shown to include a cluster 910 of nodes (912, 914, 916, and 918). According to different embodiments, each node may include one or more storage devices such as, for example, one or more solid state drives (SSDs). In the example embodiment of FIG. 9, it is assumed for purposes of illustration that three different clients (e.g., Client A 902, Client B 904, and Client C 906) are each actively engaged in the reading/writing of data from/to storage cluster 910.

Additionally, as illustrated in the example embodiment of FIG. 9, each node may have associated therewith one or more services (e.g., Services A-H), wherein each service may be configured or designed to handle a particular set of functions and/or tasks. For example, as illustrated in the example embodiment of FIG. 9: Services A and B may be associated with (and/or may be handled by) Node 1 (912); Services C and D may be associated with (and/or may be handled by) Node 2 (914); Service E may be associated with (and/or may be handled by) Node 3 (916); Services F, G, H may be associated with (and/or may be handled by) Node 4 (918). In at least one embodiment, one or more of the services may be configured or designed to implement a slice server. A slice server can also be described as providing slice service functionality.

Additionally, according to different embodiments, a given service may have associated therewith at least one primary role and further may have associated therewith one or more secondary roles. For example, in the example embodiment of FIG. 9, it is assumed that Service A has been configured or designed to include at least the following functionality: (1) a primary role of Service A functions as the primary slice service for Client A, and (2) a secondary role of Service A handles the data/metadata replication tasks (e.g., slice service replication tasks) relating to Client A, which, in this example involves replicating Client A's write requests (and/or other slice-related metadata for Client A) to Service C. Thus, for example, in one embodiment, write requests initiated from Client A may be received at Service A 902a, and in response, Service A may perform and/or initiate one or more of the following operations (or combinations thereof):

process the write request at Service A's slice server, which, for example, may include generating and storing related metadata at Service A's slice server;

(if needed) cause the data (of the write request) to be saved in a first location of block storage (e.g., managed by Service A);

forward (902b) the write request (and/or associated data/metadata) to Service C for replication.

In at least one embodiment, when Service C receives a copy of the Client A write request, it may respond by processing the write request at Service C's slice server, and (if needed) causing the data (of the write request) to be saved in a second location of block storage (e.g., managed by Service C) for replication or redundancy purposes. In at least one embodiment, the first and second locations of block storage may each reside at different physical nodes. Similarly Service A's slice server and Service C's slice server may each be implemented at different physical nodes.

Accordingly, in the example embodiment of FIG. 9, the processing of a Client A write request may involve two distinct block storage write operations—one initiated by Service A (the primary Service) and another initiated by Service C (the redundant Service). On the other hand, the processing of a Client A read request may only be handled by Service A (e.g., under normal conditions) since Service A is without involving Service C) since Service A is able to handle the read request without necessarily involving Service C.

For purposes of illustration, in the example embodiment of FIG. 9, it is also assumed that Service E has been configured or designed to include at least the following functionality: (1) a primary role of Service E functions as the primary slice service for Client B, and (2) a secondary role of Service E handles the data and/or metadata replication tasks (e.g., slice service replication tasks) relating to Client B, which, in this example involves replicating Client B's write requests (and/or other Slice-related metadata for Client B) to Service D. Thus, for example, in one embodiment, write requests initiated from Client B may be received at Service E 904a, and in response, Service E may perform and/or initiate one or more of the following operations (or combinations thereof):

process the write request at Service E's slice server, which, for example, may include generating and storing related metadata at Service E's slice server;

(if needed) cause the data (of the write request) to be saved in a first location of block storage (e.g., managed by Service E);

forward (904b) the write request (and/or associated data/metadata) to Service D for replication.

In at least one embodiment, when Service D receives a copy of the Client B write request, it may respond by processing the write request at Service D's slice server, and (if needed) causing the data (of the write request) to be saved in a second location of block storage (e.g., managed by Service D) for replication or redundancy purposes. In at least one embodiment, the first and second locations of block storage may each reside at different physical nodes. Similarly Service E's slice server and Service D's slice server may each be implemented at different physical nodes.

According to different embodiments, it is also possible to implement multiple replication (e.g., where the data/metadata is replicated at two or more other locations within the storage system/cluster). For example, as illustrated in the example embodiment of FIG. 9, it is assumed that Service E has been configured or designed to include at least the following functionality: (1) a primary role of Service E functions as the primary slice service for Client C, (2) a

secondary role of Service E handles the data and/or metadata replication tasks (e.g., slice service replication tasks) relating to Client C, which, in this example involves replicating Client C's write requests (and/or other Slice-related metadata for Client C) to Service C; and (3) a secondary role of Service E handles the data and/or metadata replication tasks (e.g., slice service replication tasks) relating to Client C, which, in this example involves replicating Client C's write requests (and/or other Slice-related metadata for Client C) to Service G. Thus, for example, in one embodiment, write requests initiated from Client C may be received at Service E **906a**, and in response, Service E may perform and/or initiate one or more of the following operations (or combinations thereof):

- process the write request at Service E's slice server, which, for example, may include generating and storing related metadata at Service E's slice server;
- (if needed) cause the data (of the write request) to be saved in a first location of block storage (e.g., managed by Service E);
- forward (**906b**) the write request (and/or associated data/metadata) to Service C for replication;
- forward (**906c**) the write request (and/or associated data/metadata) to Service G for replication.

In at least one embodiment, when Service C receives a copy of the Client C write request, it may respond by processing the write request at Service C's slice server, and (if needed) causing the data (of the write request) to be saved in a second location of block storage (e.g., managed by Service C) for replication or redundancy purposes. Similarly, In at least one embodiment, when Service G receives a copy of the Client C write request, it may respond by processing the write request at Service G's slice server, and (if needed) causing the data (of the write request) to be saved in a third location of block storage (e.g., managed by Service G) for replication or redundancy purposes.

One or more flow diagrams have been used herein. The use of flow diagrams is not meant to be limiting with respect to the order of operations performed. The herein-described subject matter sometimes illustrates different components contained within, or connected with, different other components. It is to be understood that such depicted architectures are merely exemplary, and that in fact many other architectures can be implemented which achieve the same functionality. In a conceptual sense, any arrangement of components to achieve the same functionality is effectively "associated" such that the desired functionality is achieved. Hence, any two components herein combined to achieve a particular functionality can be seen as "associated with" each other such that the desired functionality is achieved, irrespective of architectures or intermedial components. Likewise, any two components so associated can also be viewed as being "operably connected," or "operably coupled," to each other to achieve the desired functionality, and any two components capable of being so associated can also be viewed as being "operably couplable" to each other to achieve the desired functionality. Specific examples of operably couplable include but are not limited to physically mateable and/or physically interacting components and/or wirelessly interactable and/or wirelessly interacting components and/or logically interacting and/or logically interactable components.

With respect to the use of substantially any plural and/or singular terms herein, those having skill in the art can

translate from the plural to the singular and/or from the singular to the plural as is appropriate to the context and/or application. The various singular/plural permutations may be expressly set forth herein for sake of clarity.

It will be understood by those within the art that, in general, terms used herein, and especially in the appended claims (e.g., bodies of the appended claims) are generally intended as "open" terms (e.g., the term "including" should be interpreted as "including but not limited to;" the term "having" should be interpreted as "having at least," the term "includes" should be interpreted as "includes but is not limited to," etc.). It will be further understood by those within the art that if a specific number of an introduced claim recitation is intended, such an intent will be explicitly recited in the claim, and in the absence of such recitation no such intent is present. For example, as an aid to understanding, the following appended claims may contain usage of the introductory phrases "at least one" and "one or more" to introduce claim recitations. However, the use of such phrases should not be construed to imply that the introduction of a claim recitation by the indefinite articles "a" or "an" limits any particular claim containing such introduced claim recitation to inventions containing only one such recitation, even when the same claim includes the introductory phrases "one or more" or "at least one" and indefinite articles such as "a" or "an" (e.g., "a" and/or "an" should typically be interpreted to mean "at least one" or "one or more"); the same holds true for the use of definite articles used to introduce claim recitations. In addition, even if a specific number of an introduced claim recitation is explicitly recited, those skilled in the art will recognize that such recitation should typically be interpreted to mean at least the recited number (e.g., the bare recitation of "two recitations," without other modifiers, typically means at least two recitations, or two or more recitations). Furthermore, in those instances where a convention analogous to "at least one of A, B and C, etc." is used, in general such a construction is intended in the sense one having skill in the art would understand the convention (e.g., "a system having at least one of A, B, and C" would include but not be limited to systems that have A alone, B alone, C alone, A and B together, A and C together, B and C together, and/or A, B, and C together, etc.). In those instances where a convention analogous to "at least one of A, B, or C, etc." is used, in general such a construction is intended in the sense one having skill in the art would understand the convention (e.g., "a system having at least one of A, B, or C" would include but not be limited to systems that have A alone, B alone, C alone, A and B together, A and C together, B and C together, and/or A, B, and C together, etc.). It will be further understood by those within the art that virtually any disjunctive word and/or phrase presenting two or more alternative terms, whether in the description, claims, or drawings, should be understood to contemplate the possibilities of including one of the terms, either of the terms, or both terms. For example, the phrase "A or B" will be understood to include the possibilities of "A" or "B" or "A and B."

The foregoing description of illustrative implementations has been presented for purposes of illustration and of description. It is not intended to be exhaustive or limiting with respect to the precise form disclosed, and modifications and variations are possible in light of the above teachings or may be acquired from practice of the disclosed implementations. It is intended that the scope of the invention be defined by the claims appended hereto and their equivalents.

What is claimed is:

1. A method comprising:
 - receiving, by a storage system, a request from a client to write data to the storage system;
 - estimating, by the storage system, based on the request, a requested write quality of service (QoS) parameter for the client for storing the data by the storage system during a first time period;
 - determining, by the storage system, a target write QoS parameter for the client based on a system metric associated with the storage system reflecting usage of the storage system, the estimated requested write QoS parameter and an allocated write QoS parameter for the client; and
 - independently regulating, by the storage system, read performance and write performance of the client using a controller, to adjust the write performance toward the determined target write QoS parameter within the first time period based on feedback regarding a performance metric indicative of a current write performance by the client.
2. The method of claim 1, wherein said independently regulating does not increase a latency of processing a request from the client to read data from the storage system during the first time period.
3. The method of claim 1, wherein the requested write QoS parameter, the target write QoS parameter, and the allocated write QoS parameter comprise values expressed in terms of input/output operations per second (IOPS), bandwidth, or latency.
4. The method of claim 3, wherein the read performance and the write performance comprise values expressed in terms of IOPS, bandwidth, or latency.
5. The method of claim 1, wherein regulation of the write performance of the client is implemented by locking out access by the client to one or more volumes associated with the storage system.
6. The method of claim 1, wherein the system metric comprises space utilization and the method further comprises determining the allocated write QoS parameter for the client based at least in part on the space utilization.
7. A storage system comprising:
 - a processor; and
 - a non-transitory computer-readable media, coupled to the processor storing instructions that when executed by the processor cause the storage system to:
 - receive a request from a client to write data to the storage system;
 - estimate, based on the request, a requested write quality of service (QoS) parameter for the client for storing the data by the storage system during a first time period;
 - determine a target write QoS parameter for the client based on a system metric associated with the storage system reflecting usage of the storage system, the estimated requested write QoS parameter and an allocated write QoS parameter for the client; and
 - independently regulate read performance and write performance of the client using a controller to adjust the write performance toward the determined target write QoS parameter within the first time period based on feedback regarding a performance metric indicative of a current write performance by the client.
8. The storage system of claim 7, wherein independent regulation of the read performance and the write performance of the client does not increase a latency of processing a request from the client to read data from the storage system during the first time period.

9. The storage system of claim 7, wherein the requested write QoS parameter, the target write QoS parameter, and the allocated write QoS parameter comprise values expressed in terms of input/output operations per second (IOPS), bandwidth, or latency.
10. The storage system of claim 9, wherein the read performance and the write performance comprise values expressed in terms of IOPS, bandwidth, or latency.
11. The storage system of claim 7, wherein regulation of the write performance of the client is implemented by locking out access by the client to one or more volumes associated with the storage system.
12. The storage system of claim 7, wherein the system metric comprises space utilization and wherein the instructions further cause the storage system to determine the allocated write QoS parameter for the client based at least in part on the space utilization.
13. The storage system of claim 7, wherein the controller comprises a proportion-integral-derivative controller.
14. A non-transitory computer readable medium containing executable program instructions that when executed by a processor of a storage system cause the storage system to:
 - receive a request from a client to write data to the storage system;
 - estimate, based on the request, a requested write quality of service (QoS) parameter for the client for storing the data by the storage system during a first time period;
 - determine a target write QoS parameter for the client based on a system metric associated with the storage system reflecting usage of the storage system, the estimated requested write QoS parameter and an allocated write QoS parameter for the client; and
 - independently regulate read performance and write performance of the client using a controller to adjust the write performance toward the determined target write QoS parameter within the first time period based on feedback regarding a performance metric indicative of a current write performance by the client.
15. The non-transitory computer readable medium of claim 14, wherein independent regulation of the read performance and the write performance of the client does not increase a latency of processing a request from the client to read data from the storage system during the first time period.
16. The non-transitory computer readable medium of claim 14, wherein the requested write QoS parameter, the target write QoS parameter, and the allocated write QoS parameter comprise values expressed in terms of input/output operations per second (IOPS), bandwidth, or latency.
17. The non-transitory computer readable medium of claim 16, wherein the read performance and the write performance comprise values expressed in terms of IOPS, bandwidth, or latency.
18. The non-transitory computer readable medium of claim 14, wherein regulation of the write performance of the client is implemented by locking out access by the client to one or more volumes associated with the storage system.
19. The non-transitory computer readable medium of claim 14, wherein the system metric comprises space utilization and wherein the instructions further cause the storage system to determine the allocated write QoS parameter for the client based at least in part on the space utilization.
20. The non-transitory computer readable medium of claim 14, wherein the controller comprises a proportion-integral-derivative controller for each of IOPS, bandwidth, and latency.