



US011871765B2

(12) **United States Patent**
Shi et al.

(10) **Patent No.:** **US 11,871,765 B2**
(45) **Date of Patent:** **Jan. 16, 2024**

(54) **MICRO PUREE MACHINE**

(56) **References Cited**

(71) Applicant: **SharkNinja Operating LLC**,
Needham, MA (US)
(72) Inventors: **Ming Li Shi**, Dong Guan (CN); **Xu Sheng Deng**, HuiZhou (CN); **Pushan He**, Shenzhen (CN); **Ping Chu**,
Kowloon (HK)

U.S. PATENT DOCUMENTS

1,428,704 A 9/1922 Petri
1,473,066 A 11/1923 Wells
(Continued)

FOREIGN PATENT DOCUMENTS

BE 409469 A 6/1935
CA 3033891 2/2018
(Continued)

(73) Assignee: **SHARKNINJA OPERATING LLC**,
Needham, MA (US)

(*) Notice: Subject to any disclaimer, the term of this patent is extended or adjusted under 35 U.S.C. 154(b) by 518 days.

OTHER PUBLICATIONS

Translation of EP-1483997 (Year: 2004).*
(Continued)

(21) Appl. No.: **17/139,567**

Primary Examiner — Bobby Yeonjin Kim

(22) Filed: **Dec. 31, 2020**

(74) *Attorney, Agent, or Firm* — Burns & Levinson, LLP;
Joseph M. Maraia

(65) **Prior Publication Data**

US 2022/0202036 A1 Jun. 30, 2022

(51) **Int. Cl.**
A23G 9/22 (2006.01)
B01F 27/113 (2022.01)
(Continued)

(57) **ABSTRACT**

A blade assembly for a micro puree machine including a central support hub, a cutting blade, a mixing blade, a central opening, an angled ledge and an undercut. The cutting blade extends outward from a circumferential surface of the central support hub and defines a curved leading edge. The central opening is configured to receive a power shaft therein. The angled ledge is located at an upper end of the central support hub and extends about at least a portion of an outer perimeter of the central support hub. The undercut is located on the outer perimeter of the central support hub and is positioned closer to a lower end of the central support hub than the angled ledge. The undercut includes an engagement surface that extends outwards from a central axis of the central support hub and is configured to receive and retain a clip mechanism.

(52) **U.S. Cl.**
CPC **A23G 9/224** (2013.01); **A23G 9/12** (2013.01); **B01F 27/05** (2022.01); **B01F 27/071** (2022.01);
(Continued)

(58) **Field of Classification Search**
CPC B01F 27/113; B01F 27/071; B01F 27/112;
B01F 27/172; A23G 9/224; A47J 43/0711;
(Continued)

15 Claims, 36 Drawing Sheets

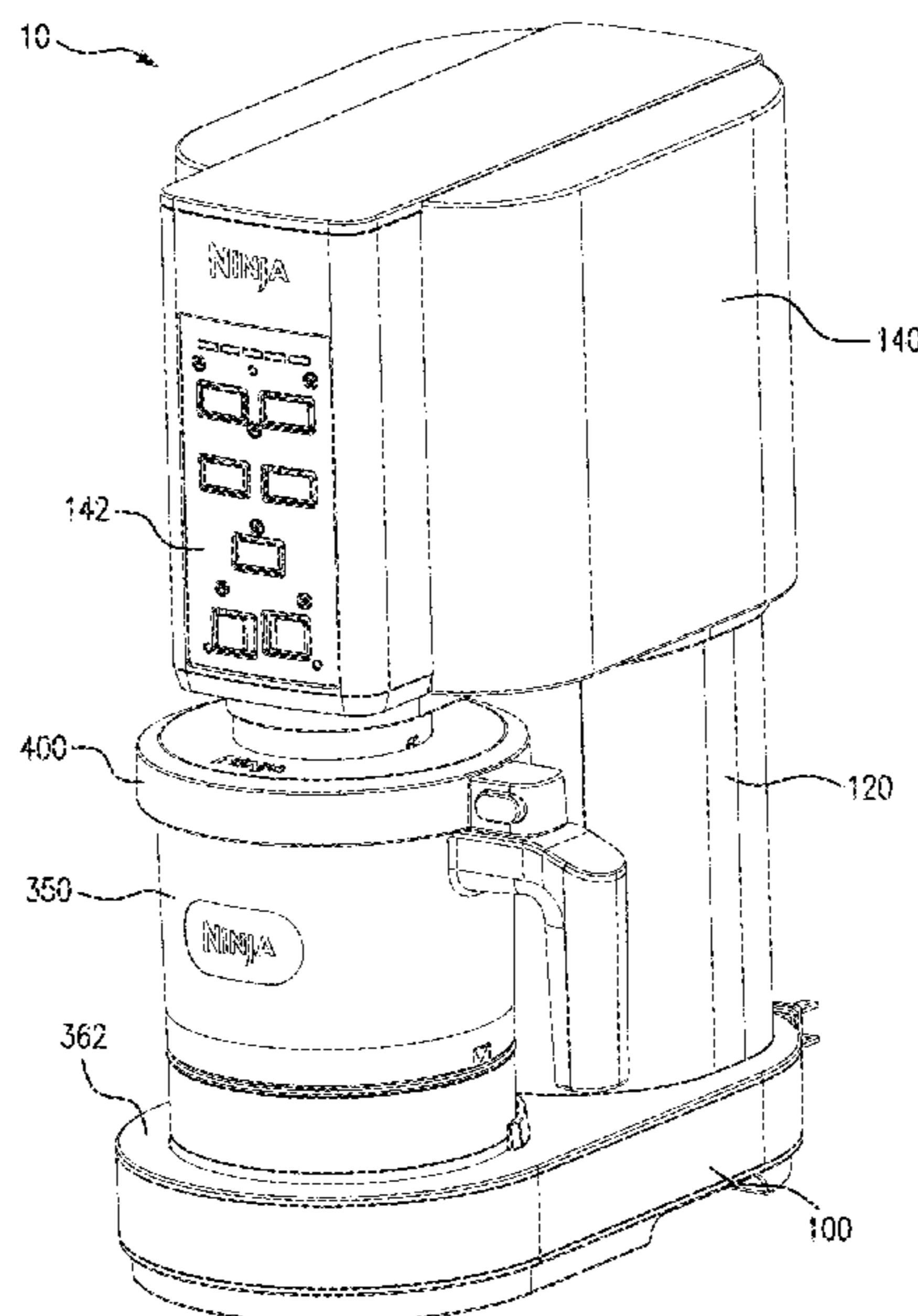

(51)	Int. Cl.		6,474,862 B2	11/2002	Farrell
	<i>B01F 27/07</i>	(2022.01)	6,494,610 B1	12/2002	Brunswick
	<i>B01F 27/05</i>	(2022.01)	6,510,704 B1	1/2003	Russell
	<i>B01F 27/91</i>	(2022.01)	6,510,890 B1	1/2003	Paskach et al.
	<i>A23G 9/12</i>	(2006.01)	6,553,779 B1	4/2003	Boyer et al.
	<i>B01F 35/43</i>	(2022.01)	D475,577 S	6/2003	Kung
	<i>B01F 27/172</i>	(2022.01)	6,599,007 B2	7/2003	Ryoo et al.
	<i>B01F 27/805</i>	(2022.01)	6,651,849 B2	11/2003	Schroeder et al.
	<i>B01F 27/112</i>	(2022.01)	6,698,228 B2	3/2004	Kateman et al.
	<i>B01F 101/13</i>	(2022.01)	6,715,706 B1	4/2004	Planca
	<i>B01F 101/00</i>	(2022.01)	6,730,348 B2	5/2004	Miller et al.
(52)	U.S. Cl.		6,735,967 B1	5/2004	Bischel et al.
	CPC	<i>B01F 27/112</i> (2022.01); <i>B01F 27/113</i> (2022.01); <i>B01F 27/172</i> (2022.01); <i>B01F 27/805</i> (2022.01); <i>B01F 27/91</i> (2022.01); <i>B01F 35/43</i> (2022.01); <i>B01F 2101/13</i> (2022.01); <i>B01F 2101/1805</i> (2022.01)	6,772,675 B2	8/2004	Ervin
			D496,213 S	9/2004	Midden et al.
			6,817,203 B1	11/2004	Rischewski
			6,817,749 B2	11/2004	Saunders et al.
			6,824,303 B2	11/2004	Huang
			6,848,356 B1	2/2005	Mueller
			6,863,916 B2	3/2005	Henriksen et al.
			6,866,414 B2	3/2005	Kupidowski
			6,892,554 B2	5/2005	Bonato et al.
(58)	Field of Classification Search		6,907,743 B2	6/2005	Cocchi et al.
	CPC	A47J 43/0722; B02C 18/18; B02C 18/08; B02C 18/06	6,923,010 B2	8/2005	Small et al.
	See application file for complete search history.		6,945,067 B2	9/2005	Petersen
			D511,066 S	11/2005	Garner
			6,966,691 B2	11/2005	Brunswick et al.
			6,991,363 B2	1/2006	Brunswick et al.
(56)	References Cited		7,014,354 B2	3/2006	Donthnier et al.
	U.S. PATENT DOCUMENTS		7,017,783 B1	3/2006	Hunter et al.
			7,028,607 B2	4/2006	Zweben
			7,047,758 B2	5/2006	Ross
			7,048,217 B2	5/2006	Dickson, Jr. et al.
			7,081,265 B2	7/2006	Wanat
			7,266,952 B2	9/2007	Ross et al.
			7,275,386 B2	10/2007	Cigolini
			7,318,703 B2	1/2008	Schober et al.
			7,325,413 B2	2/2008	Ball
			7,384,187 B2	6/2008	Blackburn et al.
			7,395,751 B2	7/2008	Liu
			7,412,845 B2	8/2008	Boulos et al.
			D577,807 S	9/2008	Kenyon et al.
			7,448,516 B2	11/2008	Davis et al.
			7,451,613 B2	11/2008	Barraclough et al.
			7,455,868 B2	11/2008	Kennedy et al.
			D587,967 S	3/2009	Wahl
			D598,712 S	8/2009	Alviar et al.
			7,572,472 B2	8/2009	Hermansen
			7,573,496 B2	8/2009	Okamura
			D600,978 S	9/2009	Poindexter et al.
			7,596,963 B2	10/2009	Rasmussen
			7,621,669 B1	11/2009	Gerber
			7,647,782 B2	1/2010	Bucceri
			7,665,398 B2	2/2010	Gerber
			7,690,835 B2	4/2010	Schnipke et al.
			7,712,321 B2	5/2010	Kadyk
			7,861,890 B2	1/2011	McGill
			D632,921 S	2/2011	Kang
			7,878,021 B2	2/2011	Perrier et al.
			7,896,038 B2	3/2011	Jones et al.
			7,950,843 B2	5/2011	Blackburn et al.
			7,997,788 B2	8/2011	Bell et al.
			D645,950 S	9/2011	Kenyon et al.
			D646,524 S	10/2011	Kortleven
			8,038,339 B2	10/2011	Jejcic
			8,109,113 B2	2/2012	Takata et al.
			8,177,418 B2	5/2012	Edwards et al.
			8,297,182 B2	10/2012	Cocchi et al.
			8,316,761 B2	11/2012	Bravo et al.
			8,322,274 B2	12/2012	Jejcic
			D678,727 S	3/2013	Kolar
			8,479,531 B2	7/2013	Maeda et al.
			8,641,265 B2	2/2014	Bravo
			D702,487 S	4/2014	Gillette
			8,746,004 B2	6/2014	Jejcic
			D708,902 S	7/2014	Audette
			8,763,420 B2	7/2014	Eichler
			8,778,436 B2	7/2014	Waletzko et al.
			8,807,469 B2	8/2014	Sung
			8,807,823 B2	8/2014	Williams

(56)

References Cited

U.S. PATENT DOCUMENTS

8,827,541 B2	9/2014	Bravo	10,701,953 B2	7/2020	Merlini
8,845,183 B2	9/2014	Kozlowski et al.	10,712,094 B2	7/2020	Cocchi et al.
8,857,197 B1	10/2014	Fisher et al.	10,736,336 B2	8/2020	Cocchi et al.
8,920,019 B2	12/2014	Kozlowski et al.	10,743,561 B2	8/2020	Smith
8,926,406 B2	1/2015	Mrak et al.	D895,348 S	9/2020	Vignau-Lous
8,944,289 B2	2/2015	Cocchi et al.	10,785,992 B2	9/2020	Newton et al.
9,016,926 B2	4/2015	Cocchi et al.	10,799,072 B2	10/2020	Ambrose et al.
D737,619 S	9/2015	Cornu et al.	10,905,134 B2	2/2021	Cocchi et al.
9,138,698 B2	9/2015	Lilja et al.	10,926,233 B2	2/2021	Goodson
9,155,322 B2	10/2015	Ricco et al.	10,945,447 B2	3/2021	Cocchi et al.
9,186,636 B2	11/2015	Dong et al.	10,952,455 B2	3/2021	Cocchi et al.
D746,883 S	1/2016	Strommer et al.	10,952,456 B2	3/2021	Cocchi et al.
9,241,501 B2	1/2016	Broadbent et al.	10,973,240 B1	4/2021	Fonte
9,301,537 B2	4/2016	Cocchi et al.	10,993,458 B2	5/2021	Cocchi et al.
9,320,290 B2	4/2016	Cocchi et al.	11,019,832 B2	6/2021	Dong
9,326,530 B2	5/2016	Ugolini	11,019,834 B2	6/2021	Bruckner et al.
9,326,531 B1	5/2016	Reich et al.	11,021,319 B2	6/2021	Fonte
9,334,874 B2	5/2016	Xia et al.	D927,931 S	8/2021	Kuchinski et al.
9,339,049 B2	5/2016	Jejcic	D932,440 S	10/2021	Huang
9,375,689 B2	6/2016	Bravo	11,154,163 B1	10/2021	He
9,393,533 B2	7/2016	Little et al.	D934,632 S	11/2021	Gross et al.
9,402,408 B2	8/2016	Cocchi et al.	11,202,999 B1	12/2021	Harrison, Jr.
D767,332 S	9/2016	Strommer et al.	11,311,847 B2	4/2022	Goldsmith
9,433,230 B1	9/2016	Fisher et al.	11,324,358 B1	5/2022	O'Loughlin
9,579,615 B2	2/2017	Farrell	D959,909 S	8/2022	Mock et al.
9,591,865 B2	3/2017	Ravji et al.	11,503,959 B2	11/2022	Proulx et al.
9,591,871 B2	3/2017	Ugolini	11,540,669 B2	1/2023	O'Loughlin et al.
9,635,874 B2	5/2017	Bruckner et al.	D983,603 S	4/2023	Shi et al.
9,763,462 B2	9/2017	He et al.	11,617,378 B2	4/2023	Shi et al.
9,816,748 B2	11/2017	Akan et al.	D985,331 S	5/2023	He et al.
9,833,109 B2	12/2017	Farrell et al.	D985,334 S	5/2023	Proulx et al.
9,854,820 B2	1/2018	Cocchi et al.	11,641,978 B2	5/2023	O'Loughlin et al.
9,883,685 B2	2/2018	Bunker et al.	11,672,382 B2	6/2023	He et al.
D812,963 S	3/2018	Smith	D992,956 S	7/2023	Kumpf
9,918,484 B2	3/2018	Ekenhorst et al.	2002/0093877 A1	7/2002	Brunswick
9,968,113 B2	5/2018	Lazzarini et al.	2003/0058734 A1	3/2003	Poitras
9,993,016 B1	6/2018	Dyer	2003/0192325 A1	10/2003	Cocchi et al.
10,004,250 B2	6/2018	Ugolini	2004/0056130 A1*	3/2004	Gursel A47J 43/0722 241/282.1
10,028,618 B1	7/2018	Benson	2004/0120213 A1	6/2004	Short
10,039,298 B2	8/2018	Noth et al.	2005/0141340 A1	6/2005	Donthnier et al.
10,111,447 B2	10/2018	Noth et al.	2005/0170054 A1	8/2005	Czark et al.
10,123,551 B2	11/2018	Beth Halachmi	2005/0183426 A1	8/2005	Learned
10,123,553 B2	11/2018	Cocchi et al.	2005/0194484 A1	9/2005	Starr
10,206,414 B2	2/2019	Cocchi et al.	2005/0207273 A1	9/2005	Newman
10,251,410 B2	4/2019	Cocchi et al.	2005/0249032 A1	11/2005	Heinhold et al.
10,285,417 B2	5/2019	Cocchi et al.	2006/0062078 A1	3/2006	Jejcic
10,306,905 B2	6/2019	Cocchi	2006/0158959 A1	7/2006	Huang
10,321,700 B2	6/2019	Cocchi et al.	2006/0171248 A1	8/2006	Chou
10,364,821 B2	7/2019	Pohler	2006/0263490 A1	11/2006	Wall et al.
10,375,973 B2	8/2019	Noth et al.	2007/0095961 A1	5/2007	Lin
D858,194 S	9/2019	Kiser	2007/0295750 A1	12/2007	Cocchi et al.
10,405,562 B2	9/2019	Cocchi et al.	2007/0297282 A1	12/2007	Procuranti
10,443,917 B2	10/2019	Kim	2008/0087026 A1	4/2008	Allin et al.
10,463,059 B2	11/2019	Bush	2008/0219090 A1	9/2008	Heinhold et al.
10,477,879 B2	11/2019	Cocchi et al.	2008/0223965 A1	9/2008	Obersteiner
10,480,524 B2	11/2019	Rhyner et al.	2008/0257173 A1	10/2008	Radi
10,512,276 B2	12/2019	Popov et al.	2008/0273419 A1	11/2008	Cocchi et al.
10,533,557 B2	1/2020	Bevington	2008/0282723 A1	11/2008	Perrier
10,542,766 B2	1/2020	Cocchi et al.	2009/0016150 A1	1/2009	Mimran
10,561,158 B2	2/2020	Cocchi et al.	2009/0032486 A1	2/2009	Brozell et al.
10,562,672 B2	2/2020	Kolar et al.	2009/0053375 A1	2/2009	Johnson
10,568,336 B2	2/2020	Choudhary et al.	2009/0133429 A1	5/2009	Petersen
10,588,330 B2	3/2020	Cocchi et al.	2009/0142466 A1	6/2009	Robinson et al.
10,602,755 B2	3/2020	Cocchi et al.	2009/0280214 A1	11/2009	Kim et al.
10,617,130 B2	4/2020	Cocchi et al.	2010/0246320 A1	9/2010	Sands
10,617,131 B2	4/2020	Lazzarini et al.	2011/0174654 A1	7/2011	Krasznai
10,624,363 B2	4/2020	Rizvi et al.	2012/0039721 A1	2/2012	Lilja et al.
D884,408 S	5/2020	Okmen	2012/0080549 A1*	4/2012	Rukavina B01F 27/112 241/282.1
10,660,348 B2	5/2020	Cheung	2012/0144676 A1	6/2012	Davidian
10,660,349 B2	5/2020	Cocchi et al.	2012/0170404 A1	7/2012	Drees et al.
10,674,742 B2	6/2020	Abu-Ali	2013/0265847 A1	10/2013	Little et al.
10,674,743 B2	6/2020	Ugolini	2013/0340456 A1	12/2013	Hoare et al.
10,674,744 B2	6/2020	Cocchi et al.	2014/0007779 A1	1/2014	Hoare et al.
10,694,895 B2	6/2020	Zakowski	2014/0117130 A1*	5/2014	Conti B01F 27/071 241/282.2
D891,634 S	7/2020	Skakoon	2014/0130538 A1	5/2014	Bond et al.
			2014/0199448 A1	7/2014	Shalev

(56)

References Cited

U.S. PATENT DOCUMENTS

2014/0332612	A1	11/2014	Liao et al.	CN	2560215	Y	7/2003
2015/0044344	A1	2/2015	Choi	CN	2576011	Y	10/2003
2015/0097063	A1	4/2015	Hsu	CN	2587189	Y	11/2003
2015/0245637	A1	9/2015	Bocchini	CN	2590387	Y	12/2003
2015/0257410	A1	9/2015	Baragiola et al.	CN	2598358	Y	1/2004
2015/0313414	A1	11/2015	Gerard	CN	2609355	Y	4/2004
2015/0342413	A1	12/2015	Joao et al.	CN	2629440	Y	8/2004
2016/0016133	A1	1/2016	Merritt et al.	CN	2660908	Y	12/2004
2016/0069604	A1	3/2016	Oh	CN	2666176	Y	12/2004
2016/0158719	A1	6/2016	Gushwa et al.	CN	2667901	Y	1/2005
2016/0220069	A1	8/2016	Gardner et al.	CN	2669617	Y	1/2005
2016/0270424	A1	9/2016	Noth et al.	CN	1579194	A	2/2005
2017/0042179	A1	2/2017	Thomas	CN	2719037	Y	8/2005
2017/0112326	A1	4/2017	Ochoa et al.	CN	2733910	Y	10/2005
2017/0188600	A1	7/2017	Semo Scharfman et al.	CN	2762561	Y	3/2006
2017/0209000	A1	7/2017	Dickson, Jr.	CN	2772248	Y	4/2006
2017/0215456	A1	8/2017	Noth et al.	CN	2785380	Y	6/2006
2017/0215647	A1	8/2017	Zakowski	CN	2802990	Y	8/2006
2017/0332843	A1	11/2017	Obersteiner	CN	2819134	Y	9/2006
2017/0360060	A1	12/2017	De'Longhi et al.	CN	1295977	C	1/2007
2017/0367370	A1	12/2017	Frisque et al.	CN	2855096	Y	1/2007
2018/0058742	A1	3/2018	Kim	CN	2907262	Y	6/2007
2018/0064131	A1	3/2018	Noth	CN	2935824	Y	8/2007
2018/0064132	A1	3/2018	Noth	CN	100342794	C	10/2007
2018/0078094	A1	3/2018	Haney et al.	CN	200959807		10/2007
2018/0084800	A1	3/2018	Noth	CN	201004979	Y	1/2008
2018/0093304	A1	4/2018	DeGennaro	CN	201015400	Y	2/2008
2018/0110238	A1	4/2018	Mohammed et al.	CN	201015402	Y	2/2008
2018/0263256	A1	9/2018	De'Longhi et al.	CN	201156957	Y	12/2008
2019/0075815	A1	3/2019	Cocchi et al.	CN	201174951	Y	1/2009
2019/0075971	A1	3/2019	Noca et al.	CN	201345883	Y	11/2009
2019/0110496	A1	4/2019	Cocchi et al.	CN	201352936	Y	12/2009
2019/0269148	A1	9/2019	Ait Bouziad et al.	CN	201352937	Y	12/2009
2019/0287102	A1	9/2019	Cocchi et al.	CN	201388483	Y	1/2010
2019/0313855	A1	10/2019	Ambrose et al.	CN	201388484	Y	1/2010
2019/0335786	A1	11/2019	Cocchi et al.	CN	201393518	Y	2/2010
2019/0337791	A1	11/2019	Bush	CN	201414376	Y	3/2010
2019/0343145	A1	11/2019	Cocchi et al.	CN	101744084	A	6/2010
2019/0380358	A1	12/2019	Cocchi et al.	CN	201523634	U	7/2010
2019/0390879	A1	12/2019	Cocchi et al.	CN	101810239	A	8/2010
2020/0000120	A1	1/2020	Cocchi et al.	CN	201557512		8/2010
2020/0120951	A1	4/2020	Wang	CN	201726817	U	2/2011
2020/0178560	A1	6/2020	Gerber et al.	CN	1788597	B	4/2011
2020/0196626	A1	6/2020	Cocchi et al.	CN	101138379	B	5/2011
2020/0196627	A1	6/2020	Cocchi et al.	CN	201839768	U	5/2011
2020/0221726	A1	7/2020	Cocchi et al.	CN	201888213	U	7/2011
2020/0238236	A1	7/2020	Branson, III	CN	201905193	U	7/2011
2020/0245638	A1	8/2020	Crema et al.	CN	102160593	A	8/2011
2020/0253235	A1	8/2020	Cocchi et al.	CN	201919605	U	8/2011
2020/0315218	A1	10/2020	Cocchi et al.	CN	201928933	U	8/2011
2020/0352193	A1	11/2020	Cocchi et al.	CN	201986636	U	9/2011
2020/0397017	A1	12/2020	Cocchi et al.	CN	201995529	U	10/2011
2021/0000133	A1	1/2021	Meldrum et al.	CN	202050862	U	11/2011
2021/0000298	A1	1/2021	Ambrose et al.	CN	202112243	U	1/2012
2021/0022364	A1	1/2021	Meldrum et al.	CN	202172781	U	3/2012
2021/0022365	A1	1/2021	Manz	CN	102138620	B	7/2012
2021/0106958	A1	4/2021	Medici	CN	202406999	U	9/2012
2021/0112825	A1	4/2021	Bellomare et al.	CN	202436050	U	9/2012
2021/0179323	A1	6/2021	Kreinbrink et al.	CN	202456290	U	10/2012
2021/0274974	A1	9/2021	Abraham	CN	101605464	B	11/2012
2021/0330129	A1	10/2021	Swidler	CN	101574112	B	12/2012
2021/0392918	A1	12/2021	Anand	CN	102144705	B	12/2012
2022/0030906	A1	2/2022	Springer	CN	202635510	U	1/2013
2023/0010316	A1	1/2023	White et al.	CN	202697631	U	1/2013
				CN	202722421	U	2/2013
				CN	202722422	U	2/2013
				CN	202773992	U	3/2013
				CN	202819518	U	3/2013
				CN	103082077	A	5/2013
				CN	202931999	U	5/2013
				CN	101889623	B	6/2013
				CN	202958664	U	6/2013
CH	685321	6/1995		CN	203058219	U	7/2013
CN	2418689	Y	2/2001	CN	203087447	U	7/2013
CN	2476962	Y	2/2002	CN	103262936	A	8/2013
CN	2478364	Y	2/2002	CN	203105529	U	8/2013
CN	2502525	Y	7/2002	CN	203152409	U	8/2013
CN	2515961	Y	10/2002	CN	203207110	U	9/2013
CN	2518335	Y	10/2002	CN	203233980	U	10/2013
CN	2521914	Y	11/2002	CN			

FOREIGN PATENT DOCUMENTS

(56)

References Cited

FOREIGN PATENT DOCUMENTS

CN	103404686	A	11/2013	CN	105841416	A	8/2016
CN	203262198	U	11/2013	CN	105851451	A	8/2016
CN	203279785	U	11/2013	CN	205409472	U	8/2016
CN	203279787	U	11/2013	CN	205431914	U	8/2016
CN	203290182	U	11/2013	CN	205455812	U	8/2016
CN	203407469	U	1/2014	CN	205505529	U	8/2016
CN	203467595	U	3/2014	CN	205505530	U	8/2016
CN	102048015	B	4/2014	CN	105961818	A	9/2016
CN	203534013	U	4/2014	CN	205567686	U	9/2016
CN	203563639	U	4/2014	CN	205580055	U	9/2016
CN	203590909	U	5/2014	CN	106035973	A	10/2016
CN	203597340	U	5/2014	CN	205624265	U	10/2016
CN	102987048	B	6/2014	CN	205624266	U	10/2016
CN	203661940	U	6/2014	CN	205655544	U	10/2016
CN	203725214	U	7/2014	CN	205695438	U	11/2016
CN	203744631	U	7/2014	CN	205695441	U	11/2016
CN	203748570	U	8/2014	CN	205695442	U	11/2016
CN	203748571	U	8/2014	CN	205747670	U	11/2016
CN	203748572	U	8/2014	CN	205848606	U	1/2017
CN	203748573	U	8/2014	CN	106376706	A	2/2017
CN	203748574	U	8/2014	CN	205939910	U	2/2017
CN	103168908	B	9/2014	CN	205947042	U	2/2017
CN	203827994	U	9/2014	CN	205947054	U	2/2017
CN	103211076	B	10/2014	CN	206005817	U	3/2017
CN	104115987	A	10/2014	CN	106693746		5/2017
CN	203897199	U	10/2014	CN	206182263	U	5/2017
CN	102805194	B	12/2014	CN	206196872	U	5/2017
CN	203985911	U	12/2014	CN	206196873	U	5/2017
CN	204090940	U	1/2015	CN	103190520	B	6/2017
CN	204120763	U	1/2015	CN	206213187	U	6/2017
CN	204146242	U	2/2015	CN	206227572	U	6/2017
CN	103380848	B	3/2015	CN	206227573	U	6/2017
CN	204191506	U	3/2015	CN	206227575	U	6/2017
CN	204202291	U	3/2015	CN	106979634	A	7/2017
CN	204217795	U	3/2015	CN	106982977	A	7/2017
CN	204259745	U	4/2015	CN	206354338	U	7/2017
CN	204273127	U	4/2015	CN	107019088	A	8/2017
CN	104621328	A	5/2015	CN	107027950	A	8/2017
CN	204362865	U	6/2015	CN	206413692	U	8/2017
CN	204362866	U	6/2015	CN	206443073	U	8/2017
CN	103478391	B	7/2015	CN	107125423	A	9/2017
CN	204426583	U	7/2015	CN	107175713	A	9/2017
CN	204444075	U	7/2015	CN	206525481	U	9/2017
CN	204482918	U	7/2015	CN	206547792	U	10/2017
CN	104824327	A	8/2015	CN	206576207	U	10/2017
CN	204599206	U	9/2015	CN	206620790	U	11/2017
CN	204599207	U	9/2015	CN	206739675	U	12/2017
CN	204599208	U	9/2015	CN	107616292	A	1/2018
CN	204616962	U	9/2015	CN	206821892	U	1/2018
CN	104982632	A	10/2015	CN	206821897	U	1/2018
CN	204707918	U	10/2015	CN	207023136	U	2/2018
CN	105010708	A	11/2015	CN	207023137	U	2/2018
CN	204742478	U	11/2015	CN	106221174	B	4/2018
CN	204742479	U	11/2015	CN	207201937	U	4/2018
CN	204742480	U	11/2015	CN	207220039	U	4/2018
CN	204811833	U	12/2015	CN	207269785	U	4/2018
CN	204830618	U	12/2015	CN	207285067	U	5/2018
CN	204837840	U	12/2015	CN	105758080	B	6/2018
CN	204860999	U	12/2015	CN	108271912	A	7/2018
CN	204907789	U	12/2015	CN	207590022	U	7/2018
CN	204930249	U	1/2016	CN	207653496	U	7/2018
CN	204949372	U	1/2016	CN	207716705	U	8/2018
CN	204949373	U	1/2016	CN	207721134	U	8/2018
CN	105498590		4/2016	CN	108514044	A	9/2018
CN	205161783	U	4/2016	CN	207836682	U	9/2018
CN	205161784	U	4/2016	CN	207940303	U	10/2018
CN	205180269	U	4/2016	CN	105953515	B	11/2018
CN	105685363	A	6/2016	CN	108813086	A	11/2018
CN	205093510	U	6/2016	CN	108813087	A	11/2018
CN	205308187	U	6/2016	CN	105076654	B	12/2018
CN	205337470	U	6/2016	CN	208228236	U	12/2018
CN	105758080	A	7/2016	CN	109152384	A	1/2019
CN	105767442	A	7/2016	CN	109156596	A	1/2019
CN	205358065	U	7/2016	CN	208425451	U	1/2019
CN	104279828	B	8/2016	CN	208434646	U	1/2019
				CN	105953513	B	3/2019
				CN	109431269	A	3/2019
				CN	109864173	A	6/2019
				CN	209031071	U	6/2019

(56)

References Cited

FOREIGN PATENT DOCUMENTS

CN	109997949	A	7/2019	EP	2067407	B1	8/2010
CN	209047390	U	7/2019	EP	2284465	A2	2/2011
CN	209073407	U	7/2019	EP	2402690	A2	1/2012
CN	209147536	U	7/2019	EP	1993373	B1	6/2013
CN	209251633	U	8/2019	EP	2659958		11/2013
CN	209284210	U	8/2019	EP	2140768	B1	3/2014
CN	209436192	U	9/2019	EP	2189067	B1	3/2014
CN	209489434	U	10/2019	EP	2242376	B1	6/2014
CN	110477182	A	11/2019	EP	2750517	A2	7/2014
CN	104782875	B	12/2019	EP	2560502	B1	12/2014
CN	209825085	U	12/2019	EP	2242377	B1	2/2015
CN	110651883	A	1/2020	EP	2611344	B1	7/2015
CN	209965158	U	1/2020	EP	2681009	B1	8/2015
CN	105558248	B	2/2020	EP	2755496	B1	8/2015
CN	110771717	A	2/2020	EP	2673581	B1	9/2015
CN	110810615	A	2/2020	EP	2478774	B1	7/2016
CN	210054494	U	2/2020	EP	2524603	B1	8/2016
CN	210157942	U	3/2020	EP	2862488	B1	8/2016
CN	210168943	U	3/2020	EP	2897469	B1	11/2016
CN	210203192	U	3/2020	EP	2805620	B1	2/2017
CN	210299346	U	4/2020	EP	2862450	B1	3/2017
CN	210332513	U	4/2020	EP	2277386	B1	4/2017
CN	210610902	U	5/2020	EP	2445356	B1	4/2017
CN	210625031	U	5/2020	EP	3148347	A1	4/2017
CN	111328909	A	6/2020	EP	3050616	B1	11/2017
CN	210695798	U	6/2020	EP	3247216	B1	11/2017
CN	210747048	U	6/2020	EP	2916695	B1	1/2018
CN	210901236	U	7/2020	EP	2708141	B1	4/2018
CN	210901239	U	7/2020	EP	2755497	B1	9/2018
CN	211026023	U	7/2020	EP	3369353	A1	9/2018
CN	211091708	U	7/2020	EP	3095332	B1	10/2018
CN	211091709	U	7/2020	EP	3145320	B1	12/2018
CN	106889294	B	8/2020	EP	3220749	B1	12/2018
CN	211211296	U	8/2020	EP	3426055	A1	1/2019
CN	111657388	A	9/2020	EP	3266311	B1	3/2019
CN	111657389	A	9/2020	EP	3247216	B1	4/2019
CN	211430928	U	9/2020	EP	3473950	A1	4/2019
CN	211746663	U	10/2020	EP	3331375	B1	6/2019
CN	211794135	U	10/2020	EP	3021956	B1	8/2019
CN	111887338	A	11/2020	EP	3568025	A1	11/2019
CN	111903828	A	11/2020	EP	3391752	B1	12/2019
CN	212232975	U	12/2020	EP	3305089	B1	1/2020
CN	212232976	U	12/2020	EP	3183975	B1	4/2020
CN	112219932	A	1/2021	EP	3185693	B1	4/2020
CN	212306694	U	1/2021	EP	3643180	A1	4/2020
CN	212325314	U	1/2021	EP	3091848	B1	7/2020
CN	212345191	U	1/2021	EP	3682743	A2	7/2020
CN	212414601	U	1/2021	EP	3490386	B1	8/2020
CN	212437169	U	2/2021	EP	3632473	A3	11/2020
CN	212464764	U	2/2021	EP	3058831	B1	12/2020
CN	112515503	A	3/2021	EP	3351113	B1	12/2020
CN	112715735	A	4/2021	EP	3528639	B1	12/2020
CN	212852474	U	4/2021	EP	3381295	B1	1/2021
CN	213045050	U	4/2021	EP	3758503	A1	1/2021
CN	213074319	U	4/2021	EP	3775729	A1	2/2021
DE	2905308		9/1979	EP	3291719	B1	3/2021
DE	102004008748		9/2004	EP	3292768	B1	3/2021
EP	0891139		5/2002	EP	3590351	B1	3/2021
EP	0877558	B1	7/2002	EP	3796784	A1	3/2021
EP	1264567		12/2002	EP	3801042	A1	4/2021
EP	0996341	B1	9/2003	EP	3801158	A1	4/2021
EP	1156735	B1	10/2004	FR	1104425	A	11/1955
EP	1483997	A1 *	12/2004	JP	S5931654	A	2/1984
EP	1544882	A2	6/2005	KR	20040099008	A	11/2004
EP	1588981	A1	10/2005	KR	101624283	B1	5/2016
EP	1334664	B1	12/2005	KR	20170056787	A	5/2017
EP	1449441	B1	12/2005	KR	102185180	B1	12/2020
EP	1309245	B1	3/2006	TW	M429850	U	5/2012
EP	1465499	B1	3/2006	TW	1465677	B	12/2014
EP	1637056	A2	3/2006	TW	I535986	B	6/2016
EP	1884167	A1	2/2008	WO	97/36498	A1	10/1997
EP	1068803	B1	12/2008	WO	9736498	A1	10/1997
EP	1802225	B1	4/2009	WO	0197628	A1	12/2001
EP	2070423	A1	6/2009	WO	03065819	A1	8/2003
				WO	2008/036972	A2	3/2008
				WO	2008036972	A2	3/2008
				WO	WO-2013120145	A1 *	8/2013
						 A47J 43/046

(56)

References Cited

WO 2022014808 B1 1/2022
 WO 2022020653 A1 1/2022

FOREIGN PATENT DOCUMENTS

WO 2014026445 A1 2/2014
 WO 2014206119 A1 12/2014
 WO 2015063135 A1 5/2015
 WO 2016078042 A1 5/2016
 WO 2017/090647 A1 6/2017
 WO 2017090647 A1 6/2017
 WO 2017139395 A1 8/2017
 WO 2017166007 A1 10/2017
 WO 2017166008 A1 10/2017
 WO 2018141758 A1 8/2018
 WO 2019197152 A1 10/2019
 WO 2019200490 A1 10/2019
 WO 2019/220490 A1 11/2019
 WO 2019/220491 A1 11/2019
 WO 2019220490 A1 11/2019
 WO 2019220491 A1 11/2019
 WO 2020028817 A2 2/2020
 WO 2020236173 A1 11/2020

OTHER PUBLICATIONS

Cuisinart Soft Serve Ice Cream Maker. Date First Available on Amazon.com: Oct. 2, 2001, URL: <https://www.amazon.com/Cuisinart-ICE-45-Serve-2-Quart-Cream/dp/B000F94GPQ/ref> (Year: 2001).
 “Ninja NC301 CREAMi Ice Cream Maker,” retrieved from URL: https://www.amazon.com/Ninja-NC301-placeholder-Cream-Maker/dp/B08QXB9BH5/ref=sr_1_1?keywords=ninja%2Bicecream%2Bmaker%2Bmachin&qid=1663587903&sr=8-1&th=1,9 pgs. (Pub: Aug. 17, 2021).
 Ice Cream Maker, Ninja™ CREAMi™: How to Assemble + Use, YouTube video by Ninja Kitchen; retrieved from URL: <https://www.youtube.com/watch?v=fXkq1tzxLm0>, (Jul. 27, 2021).
 Weija Cuisinart Main Stainless Steel Blade for Food Processors; date first available on Amazon.com Dec. 27, 2021, URL: <https://www.amazon.com/dp/B09P81M81J/ref> (Year: 2021).

* cited by examiner

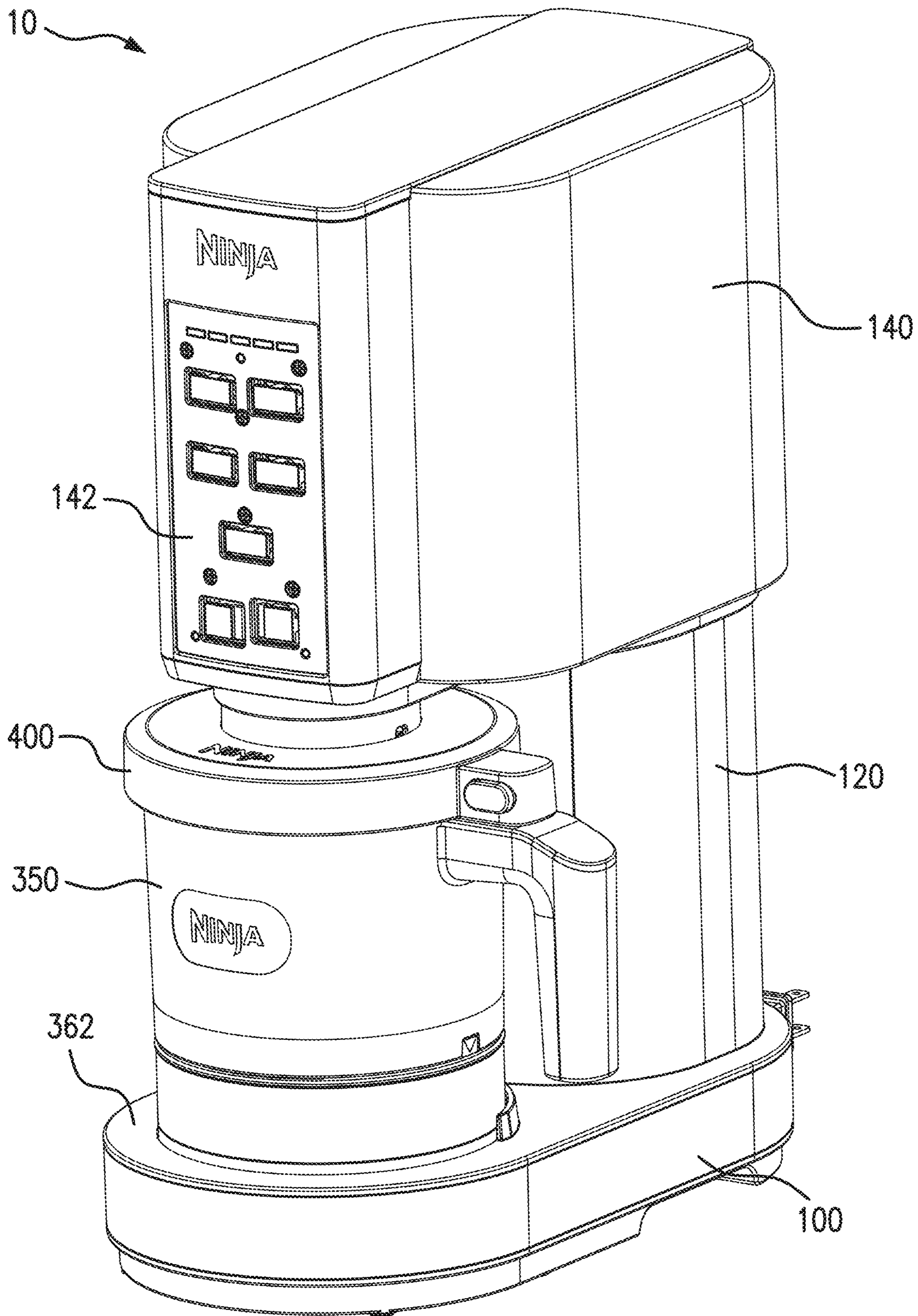

FIG. 1

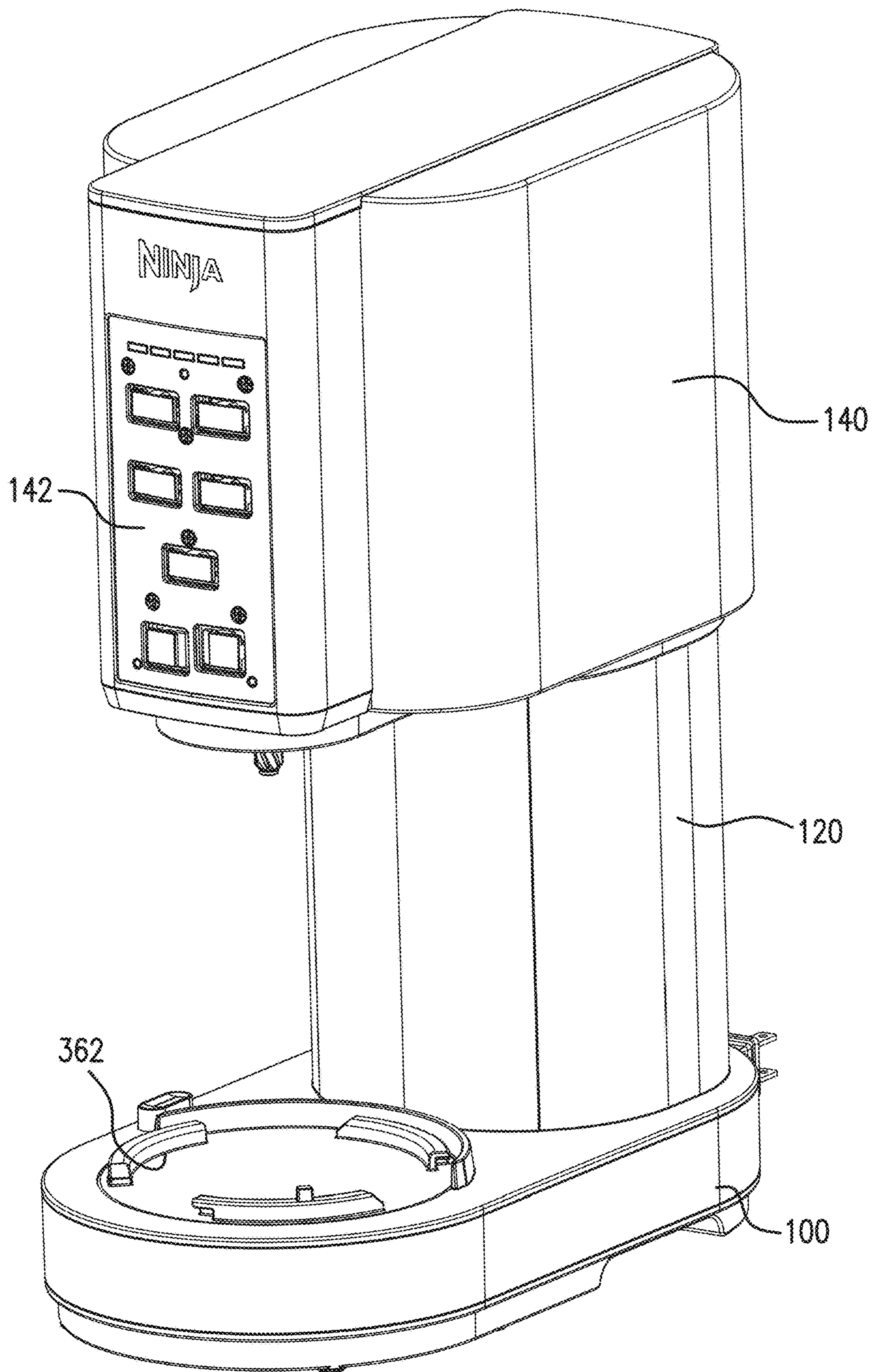

FIG. 2

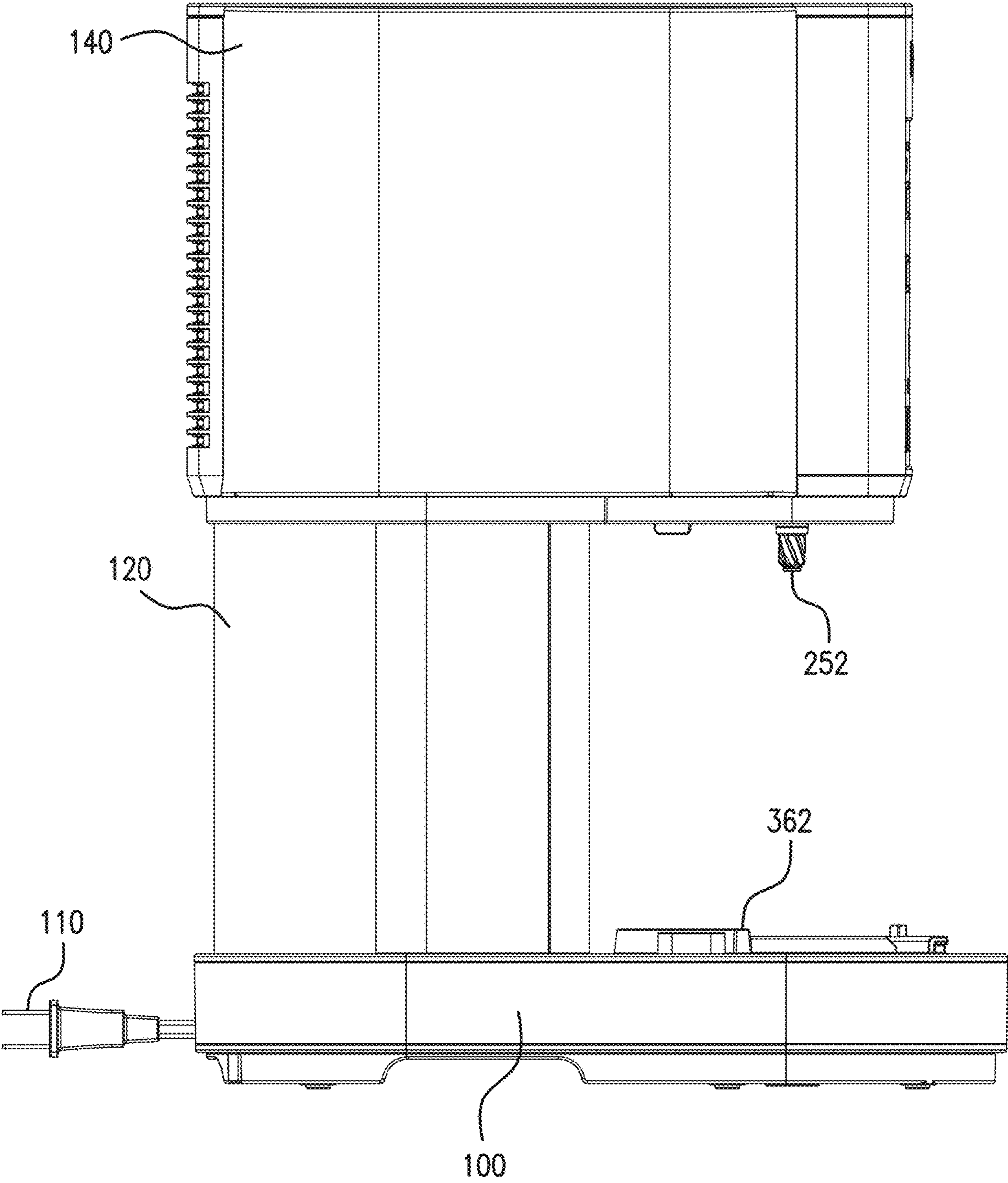

FIG. 3A

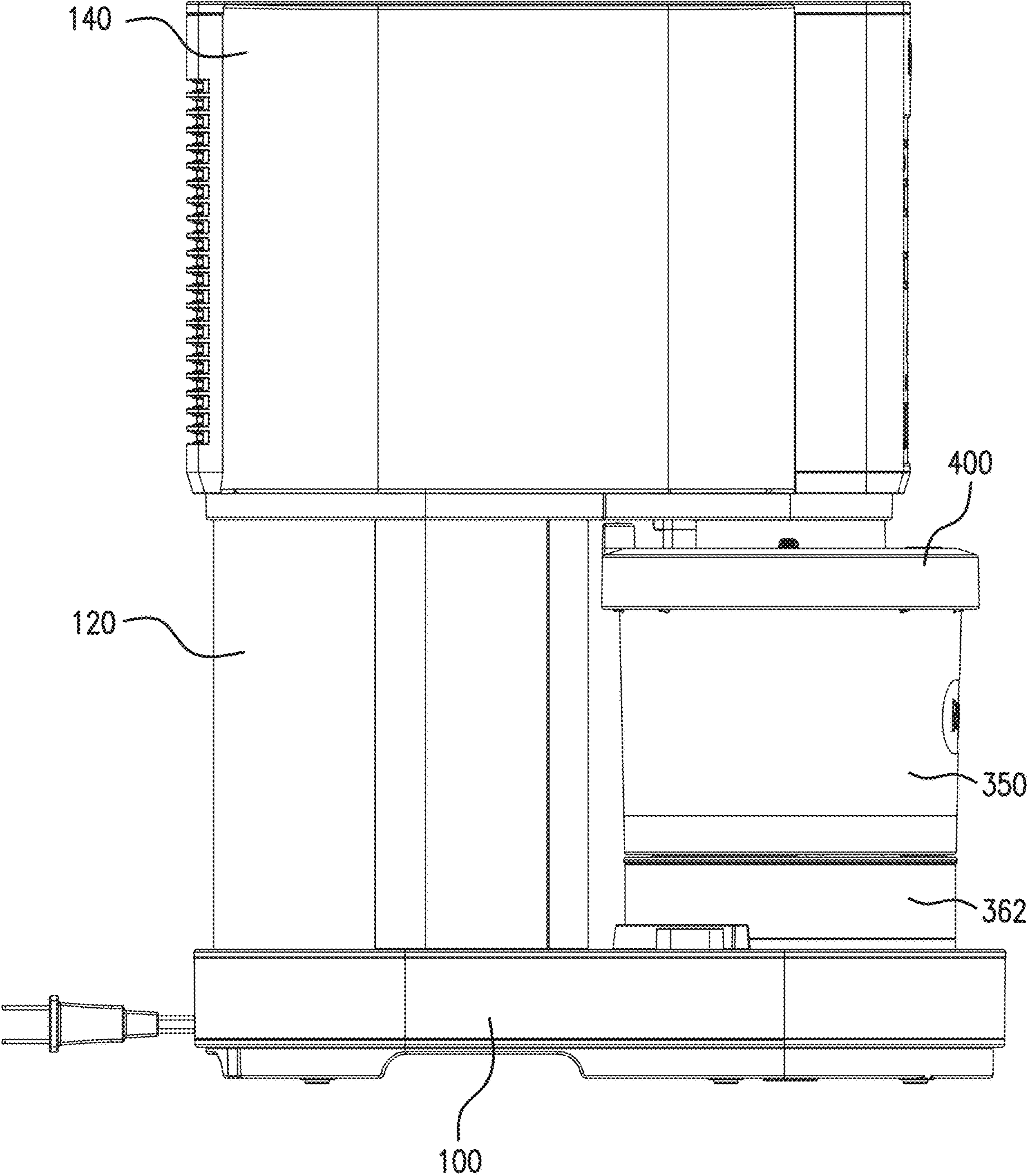

FIG. 3B

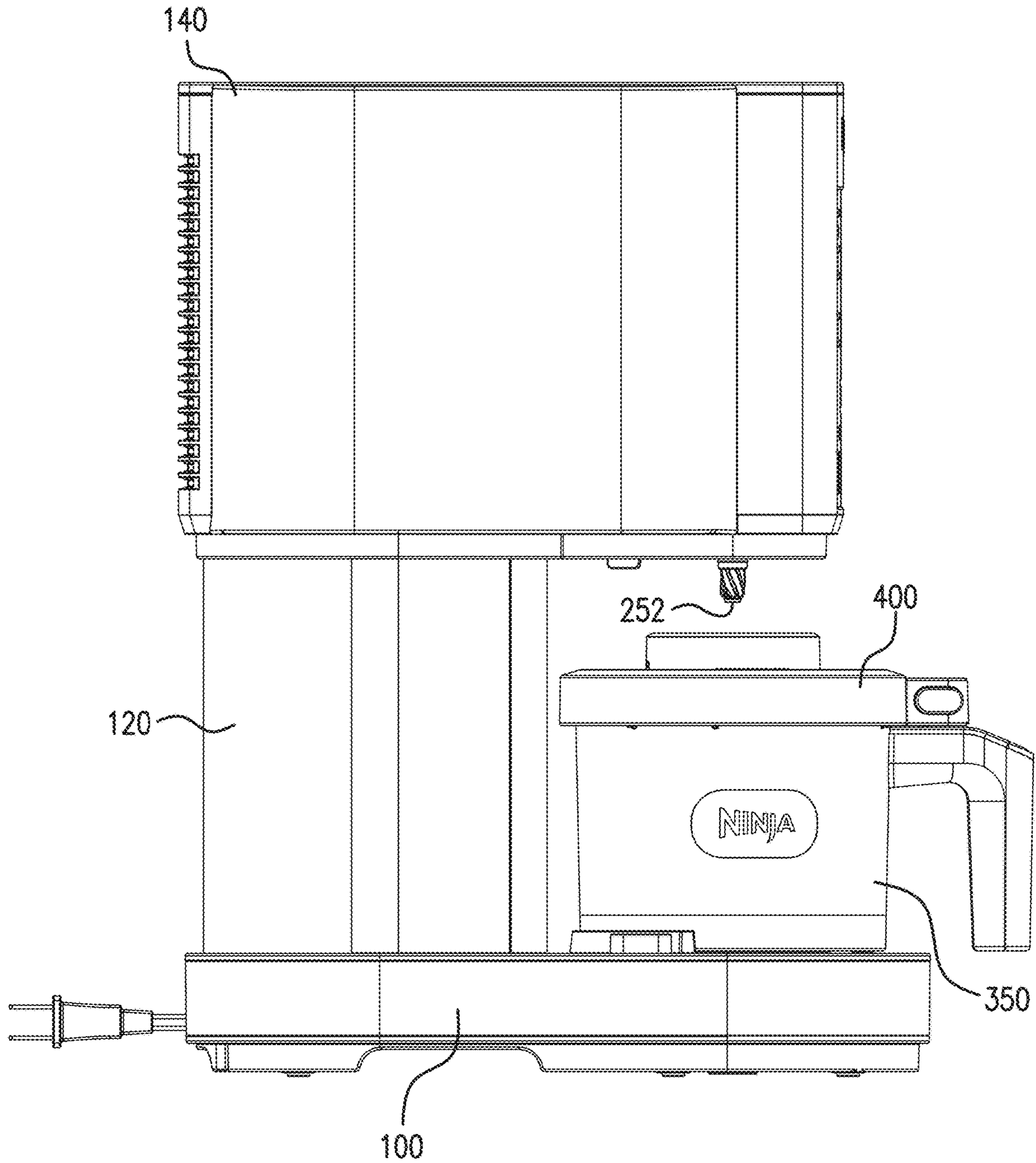

FIG. 3C

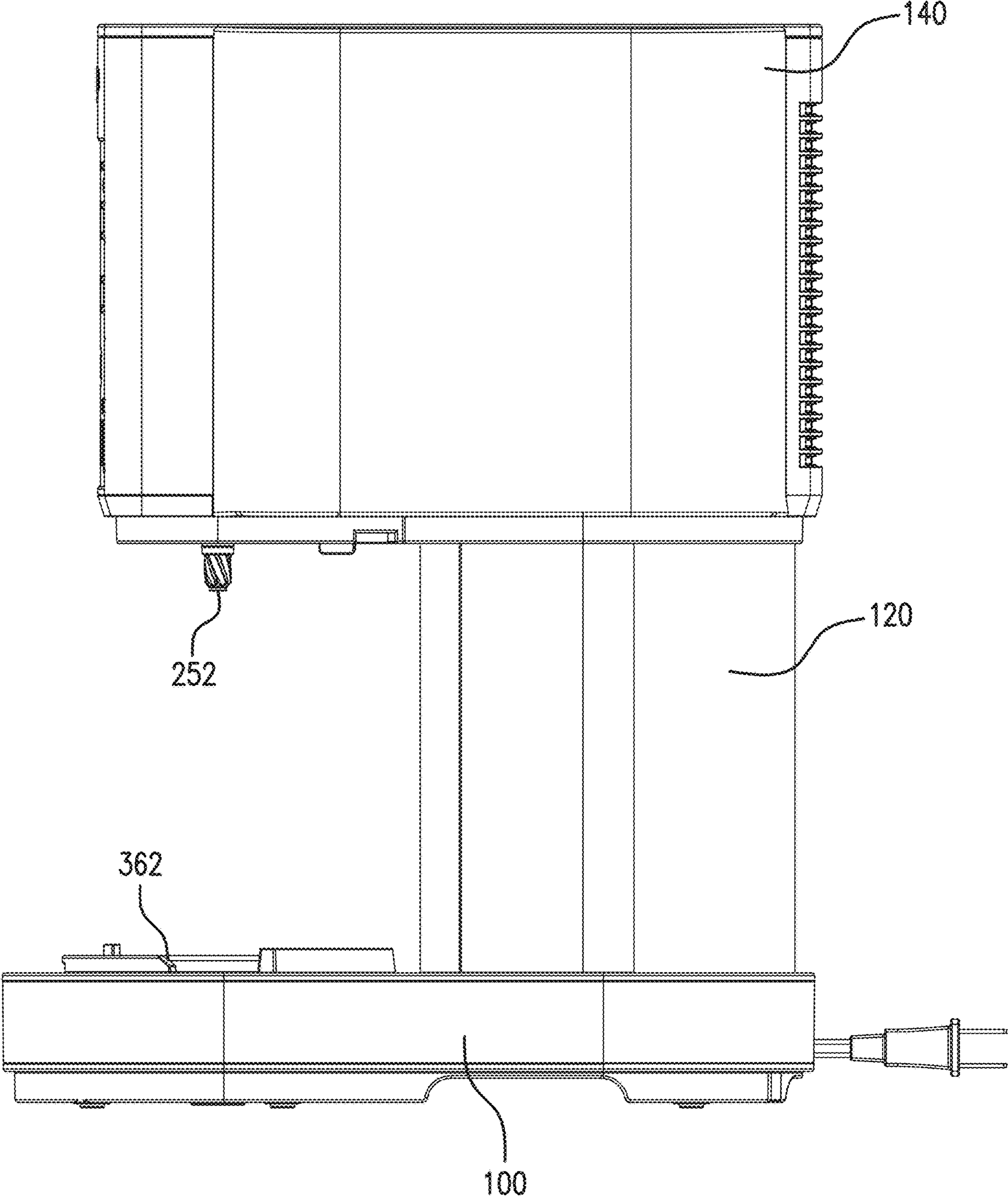

FIG. 4A

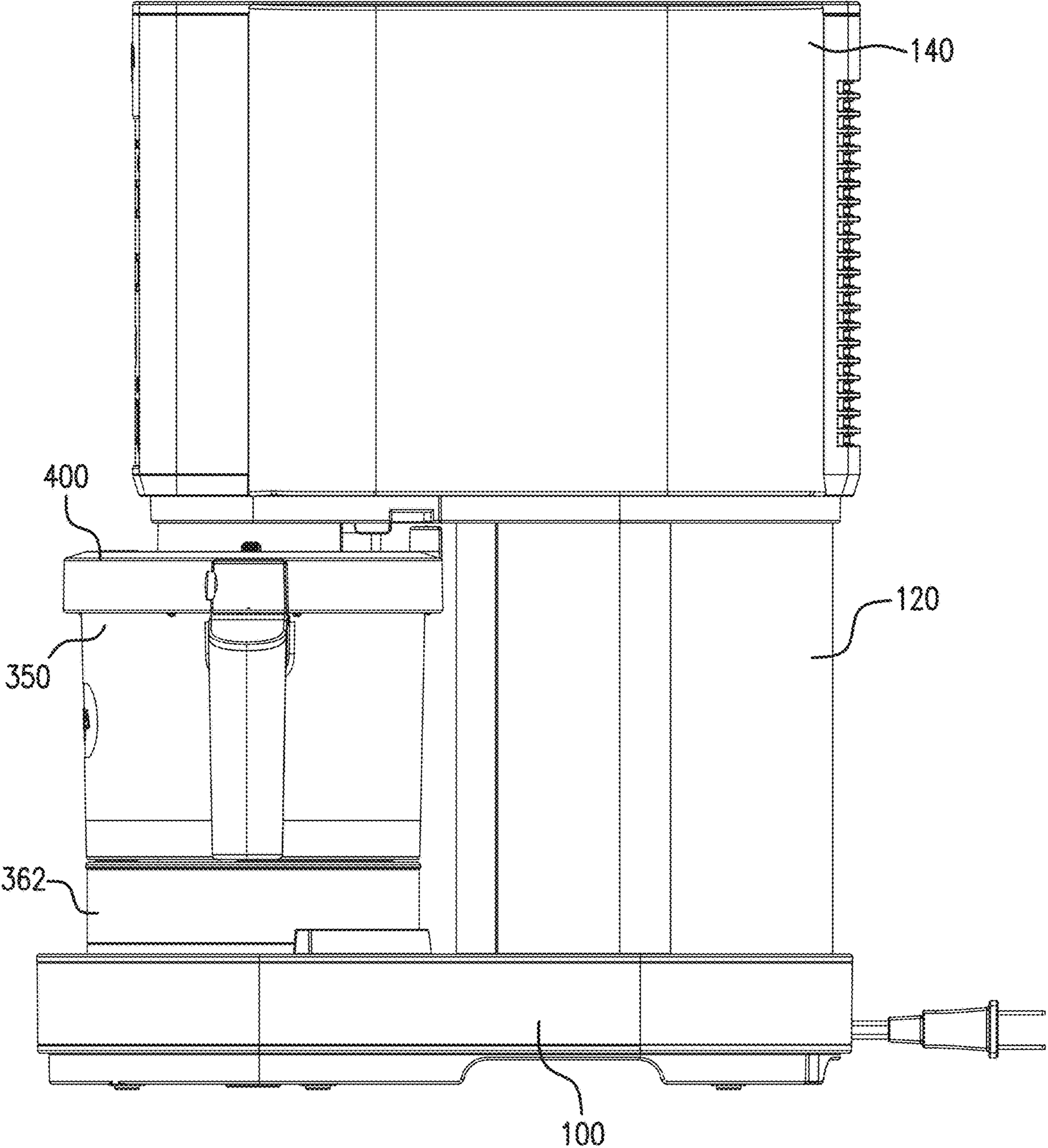

FIG. 4B

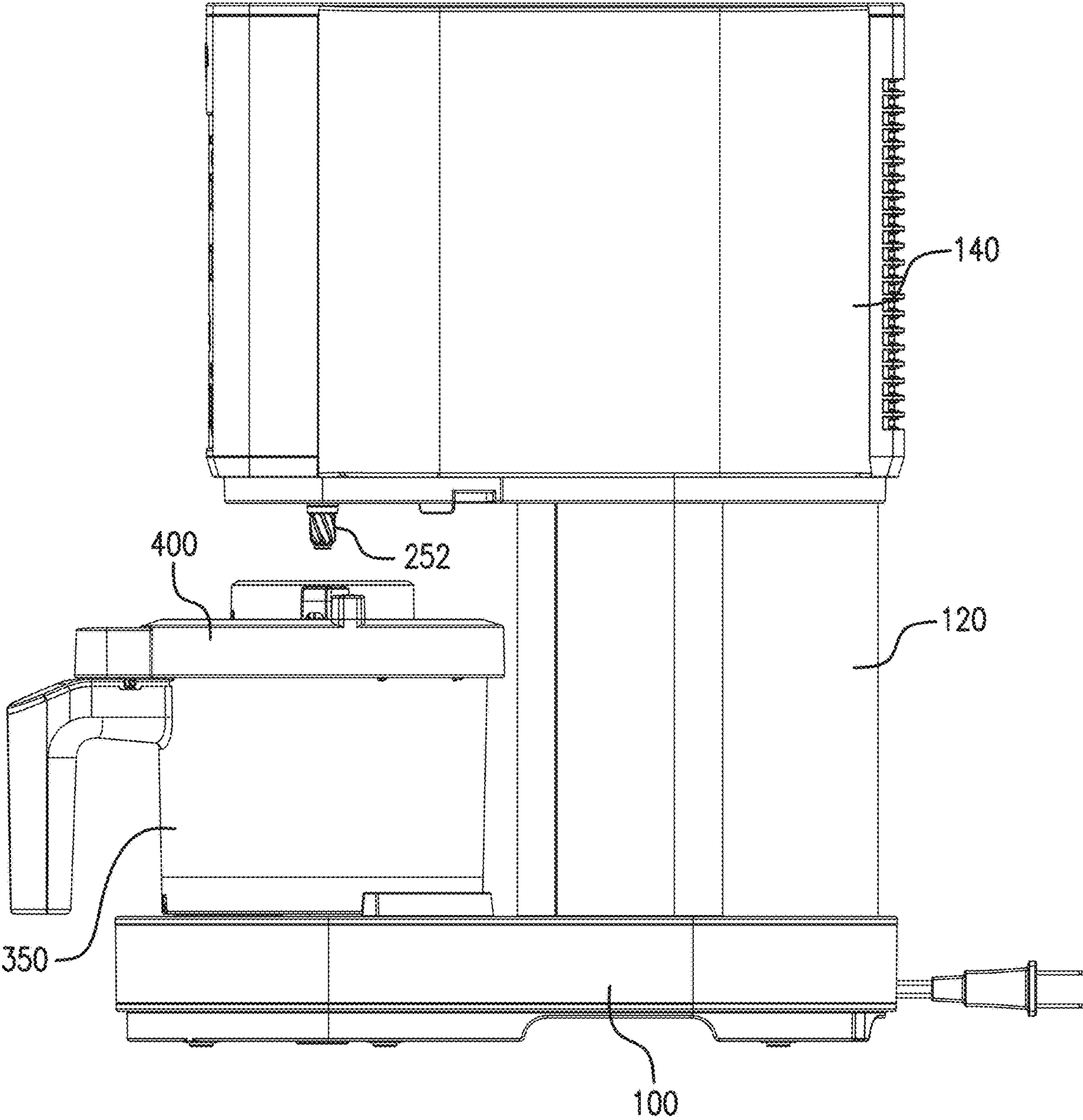
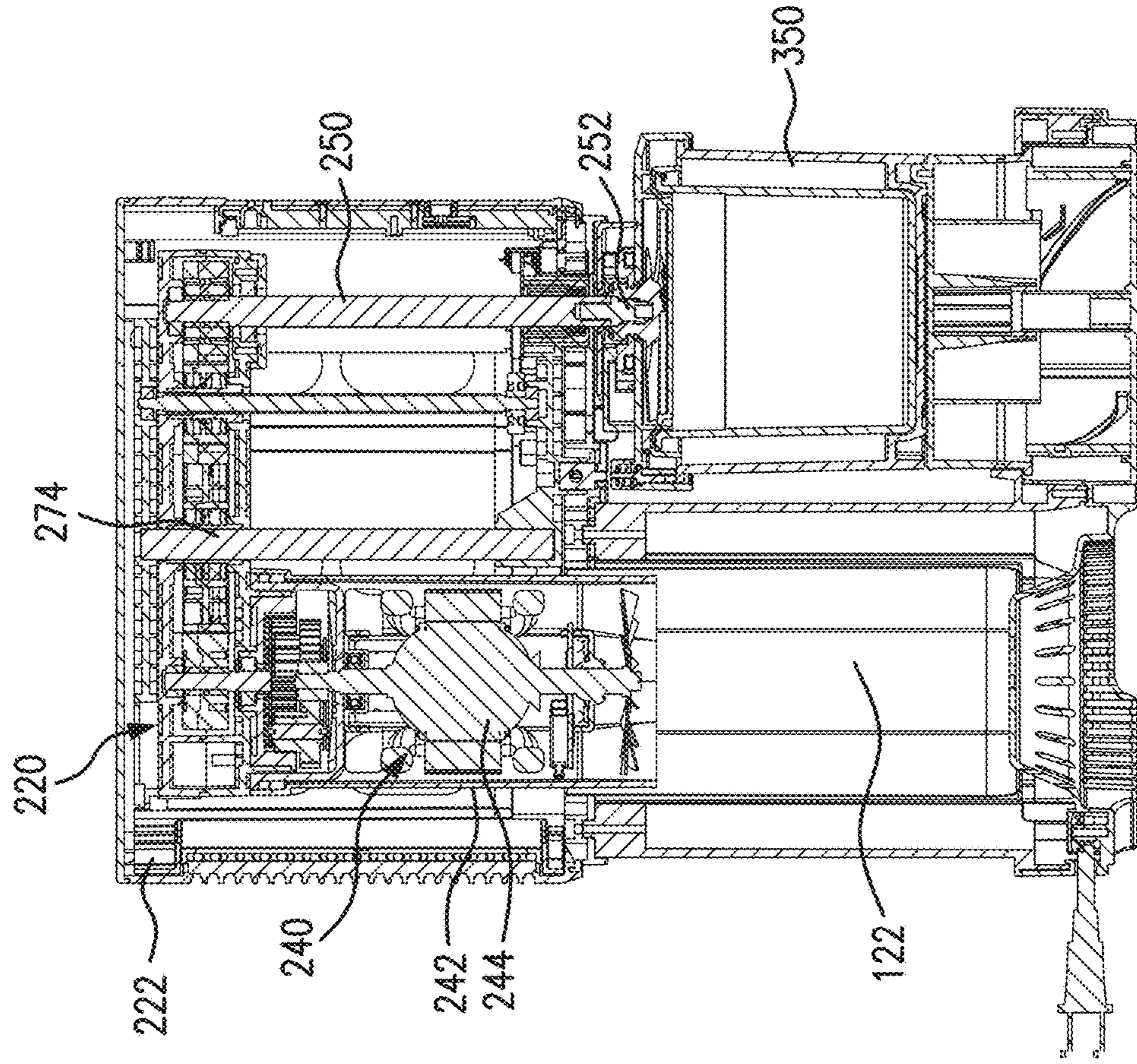
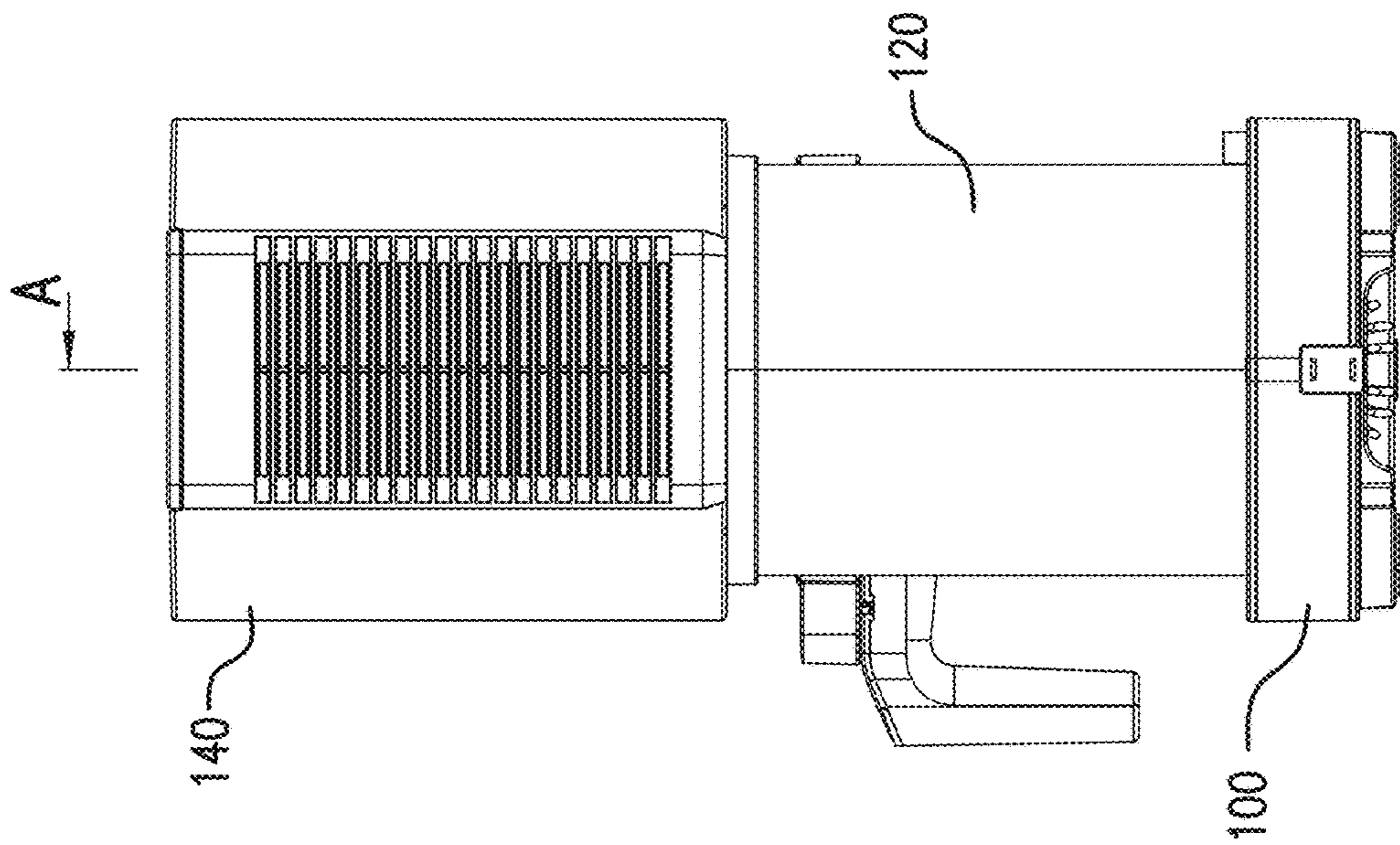

FIG. 4C



SECTION A--A

FIG. 5B

A

FIG. 5A

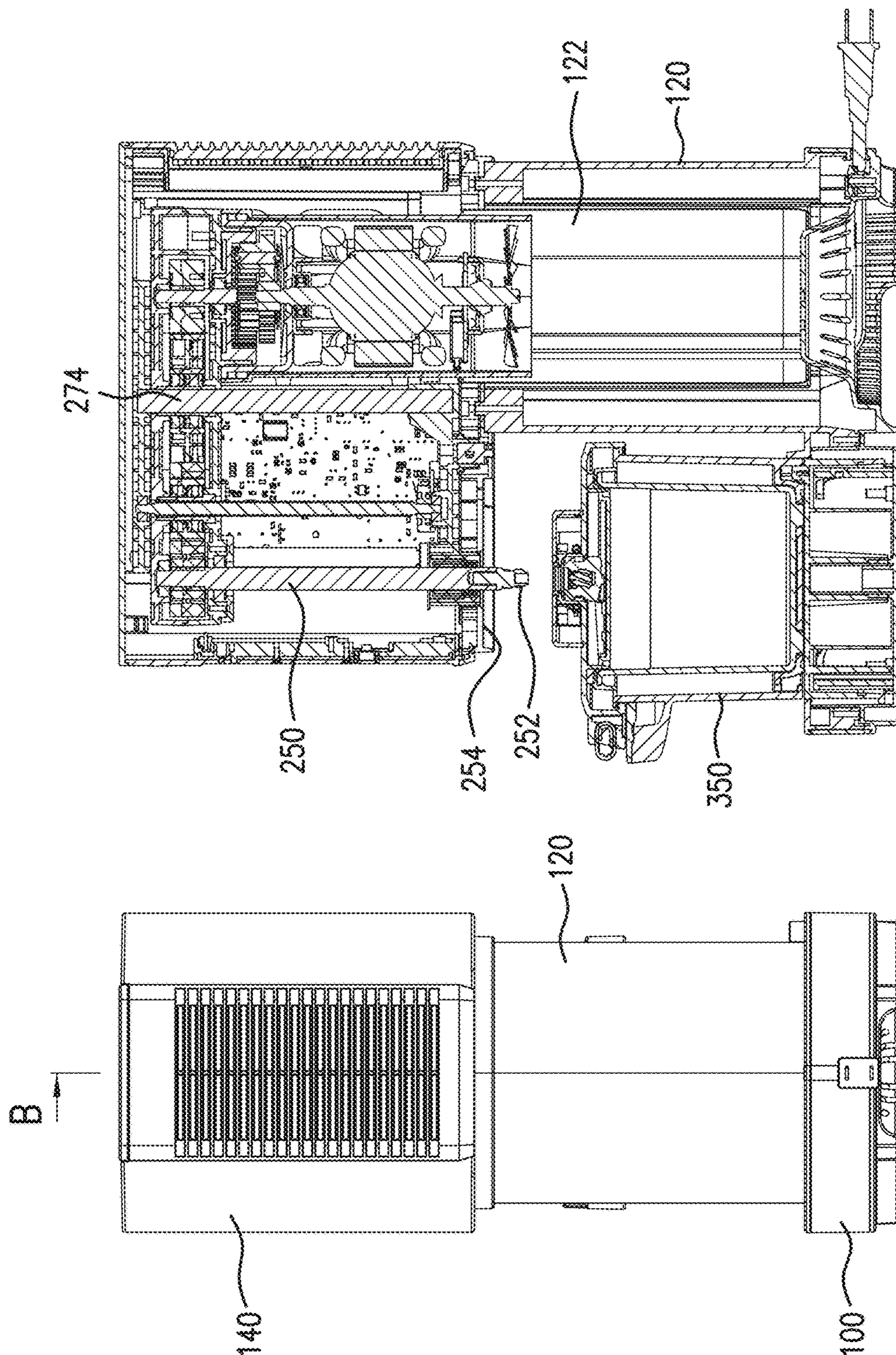

SECTION B--B

FIG. 6B

B

FIG. 6A

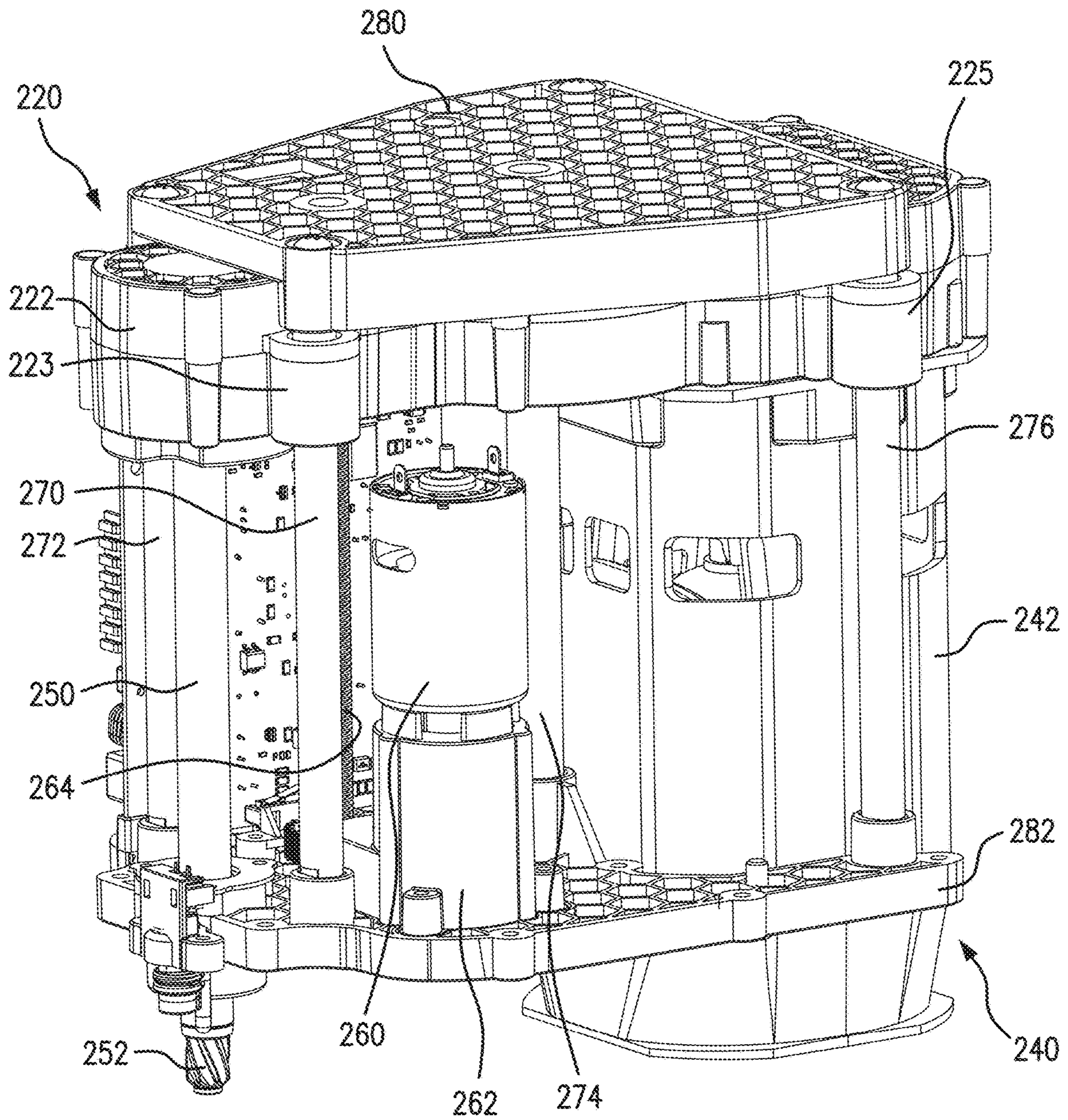

FIG. 7

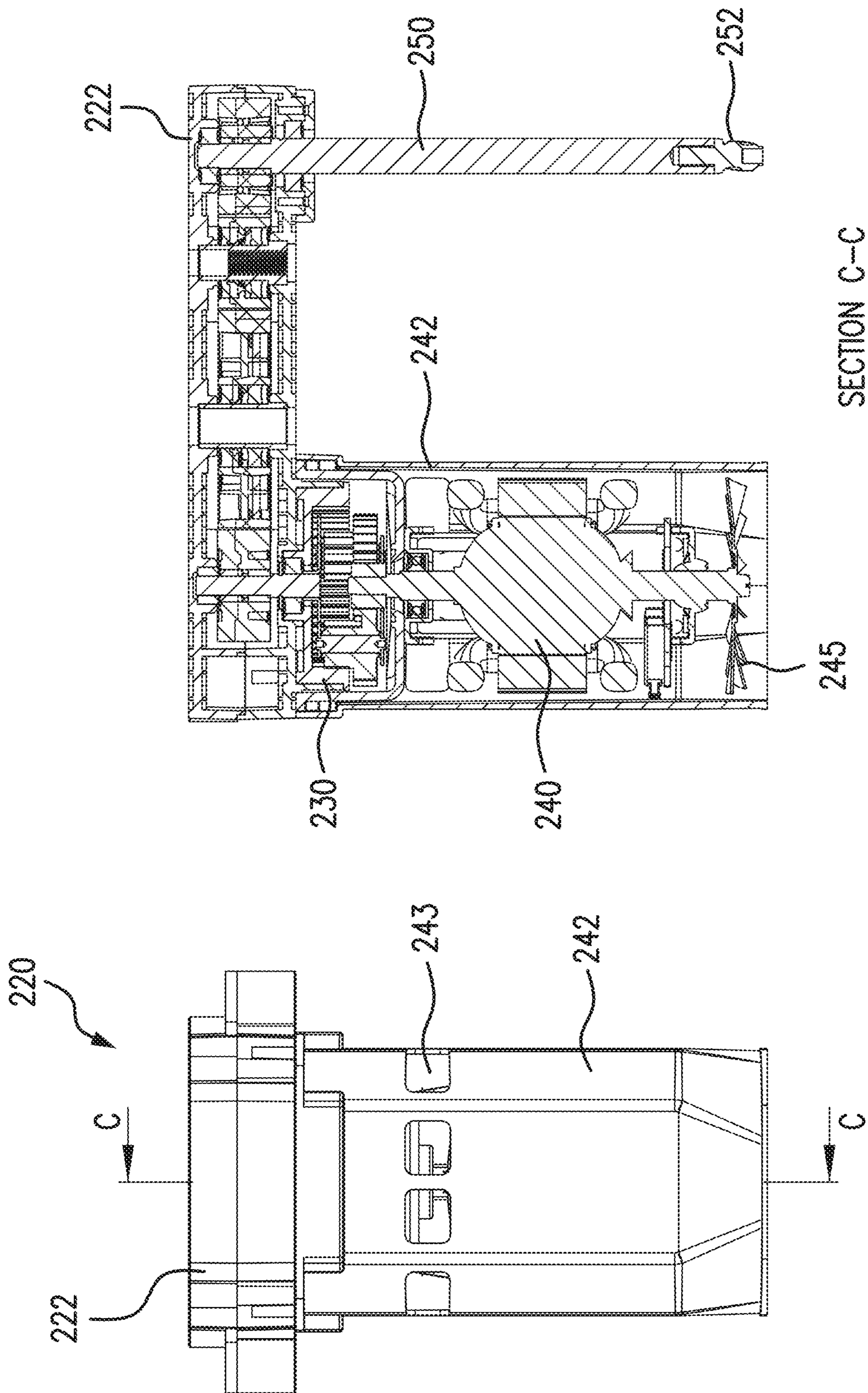

FIG. 8B

FIG. 8A

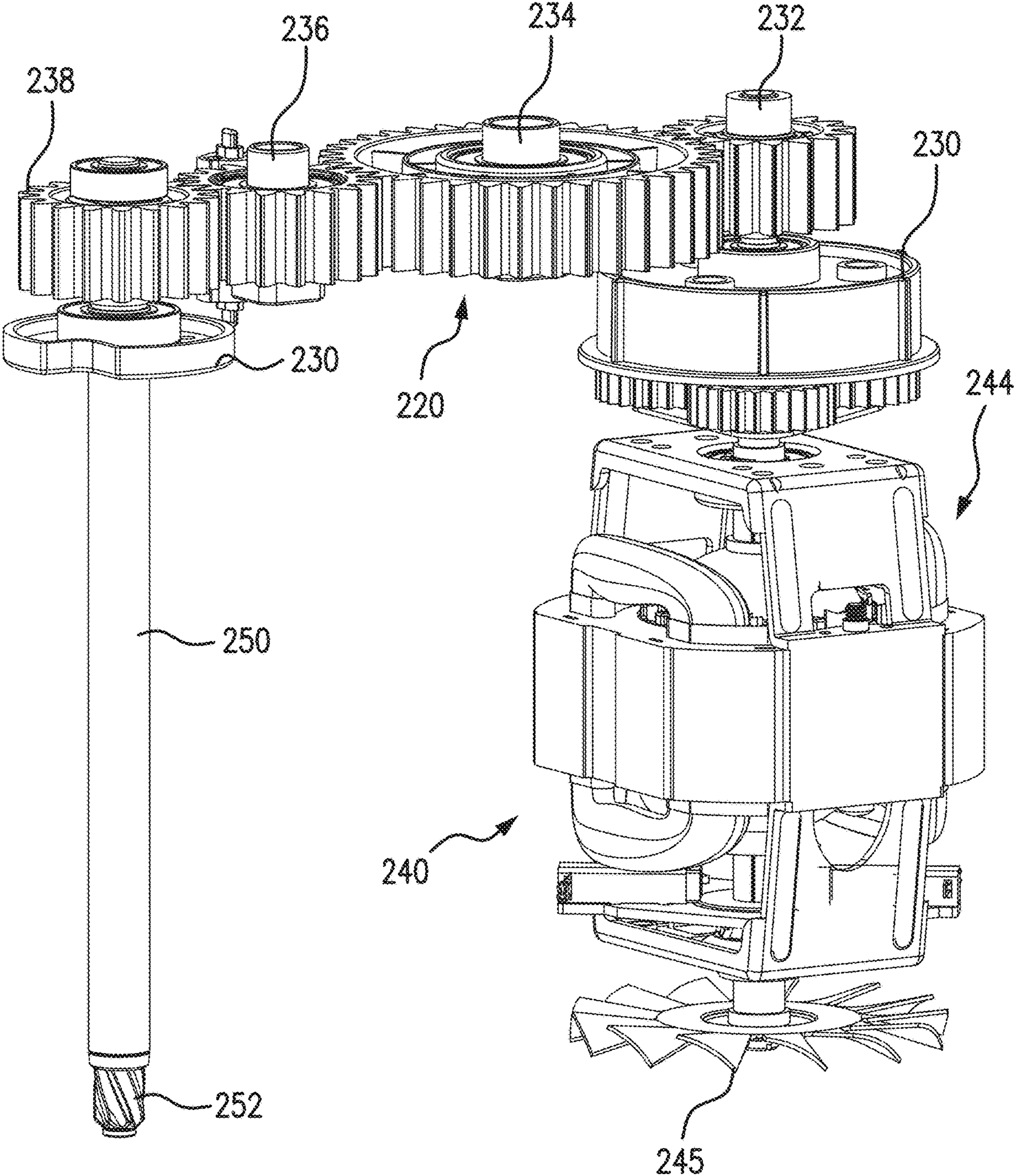

FIG. 9

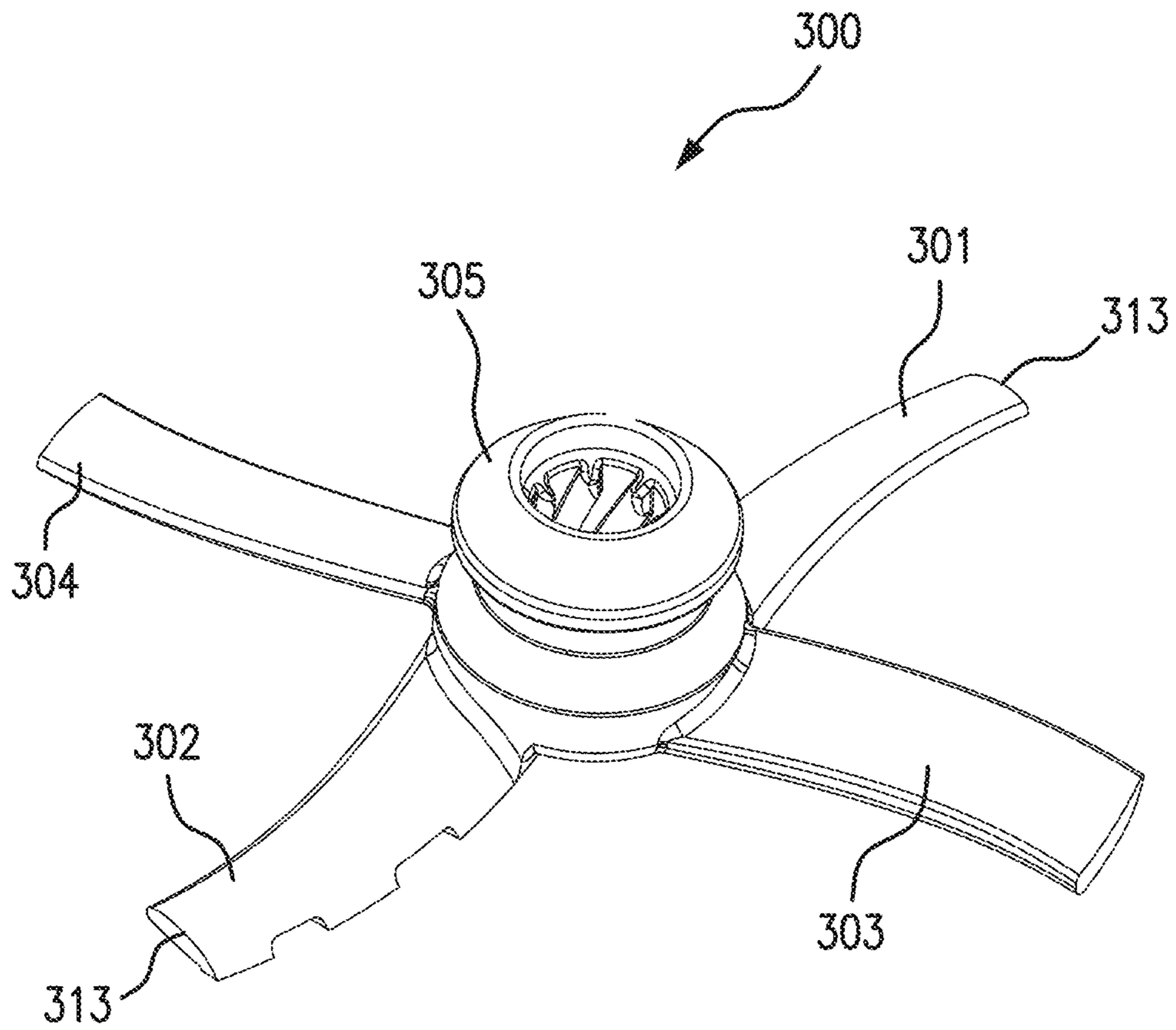

FIG. 10

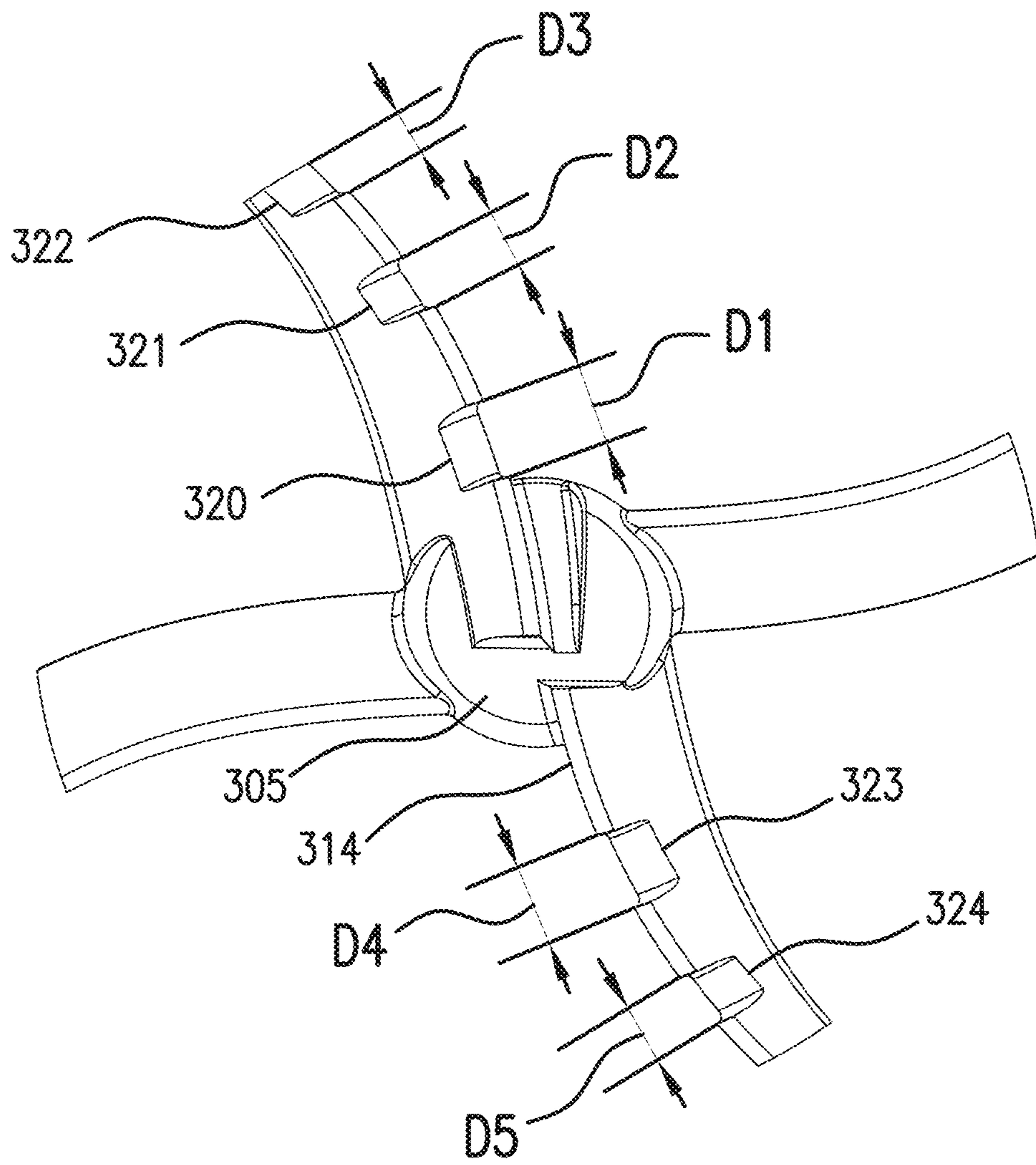

FIG. 11

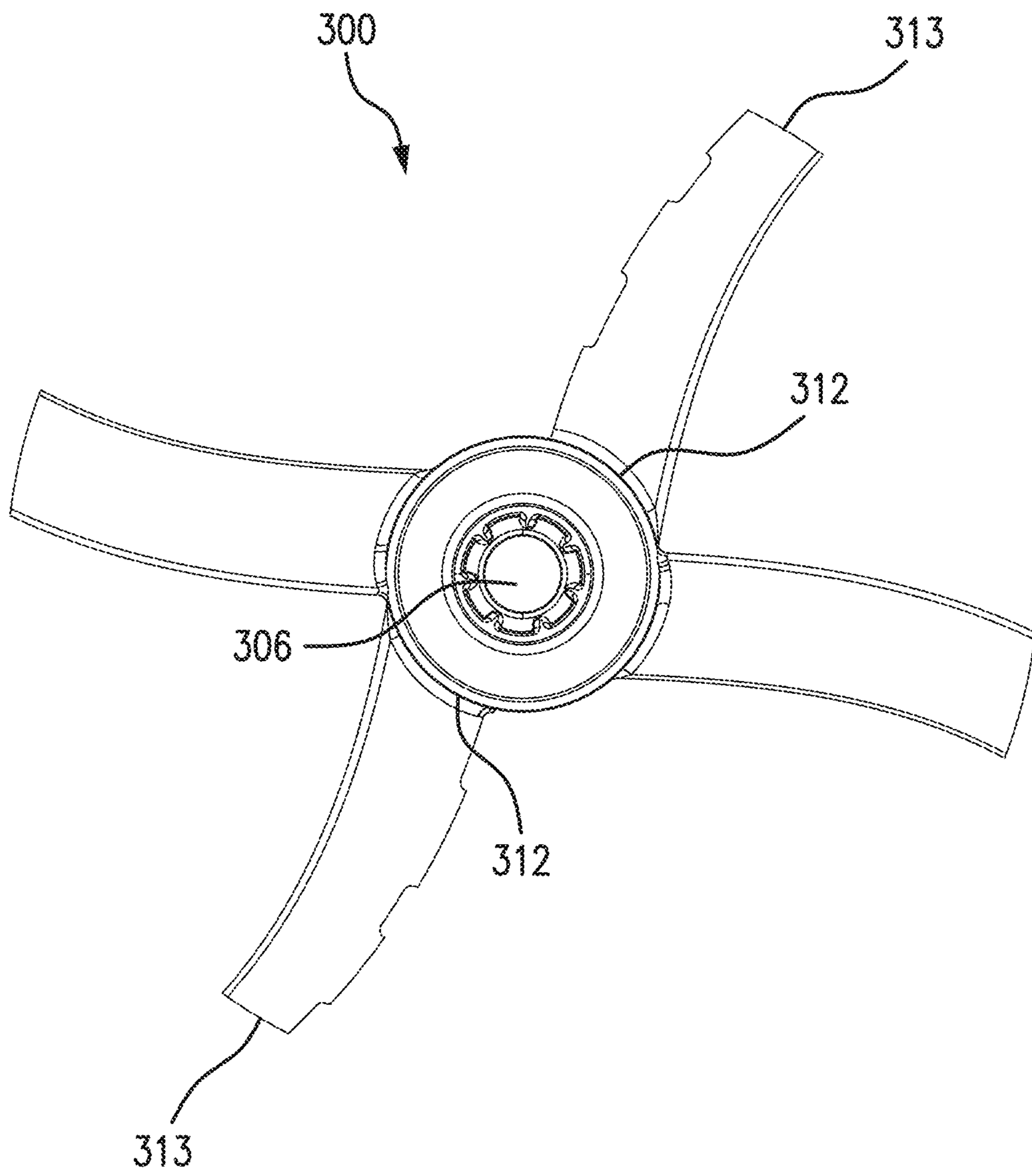

FIG. 12

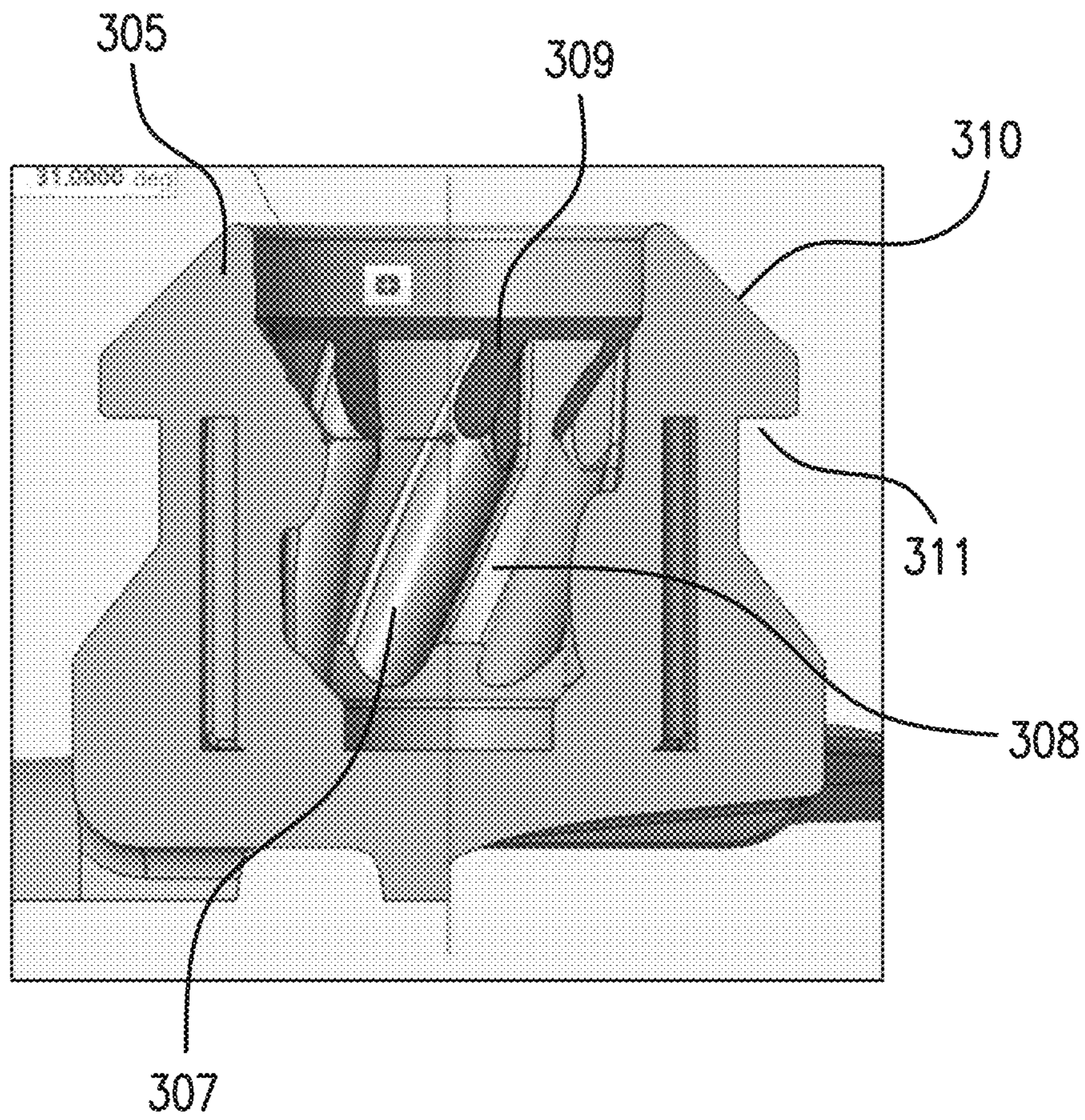

FIG. 13A

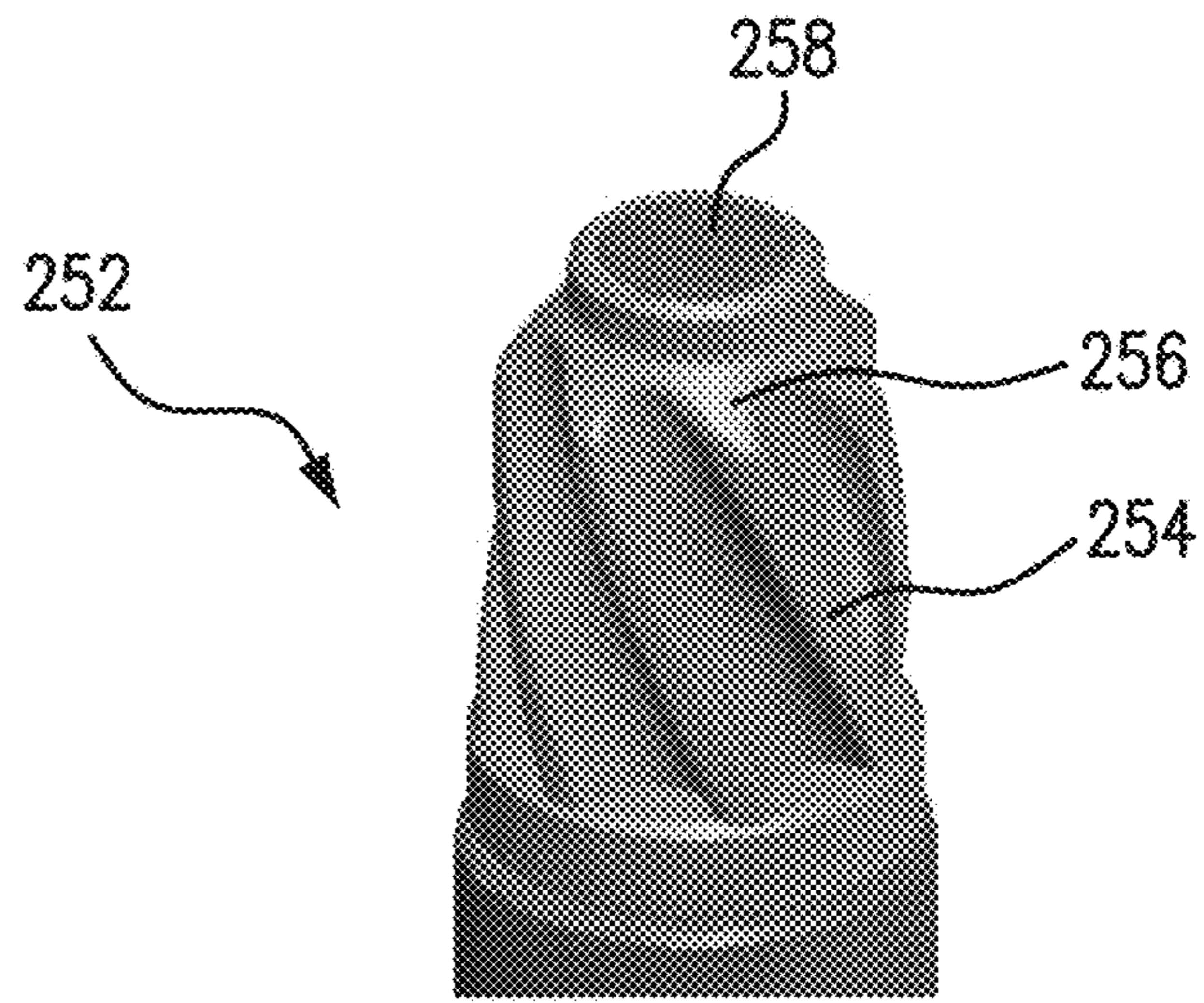

FIG. 14A

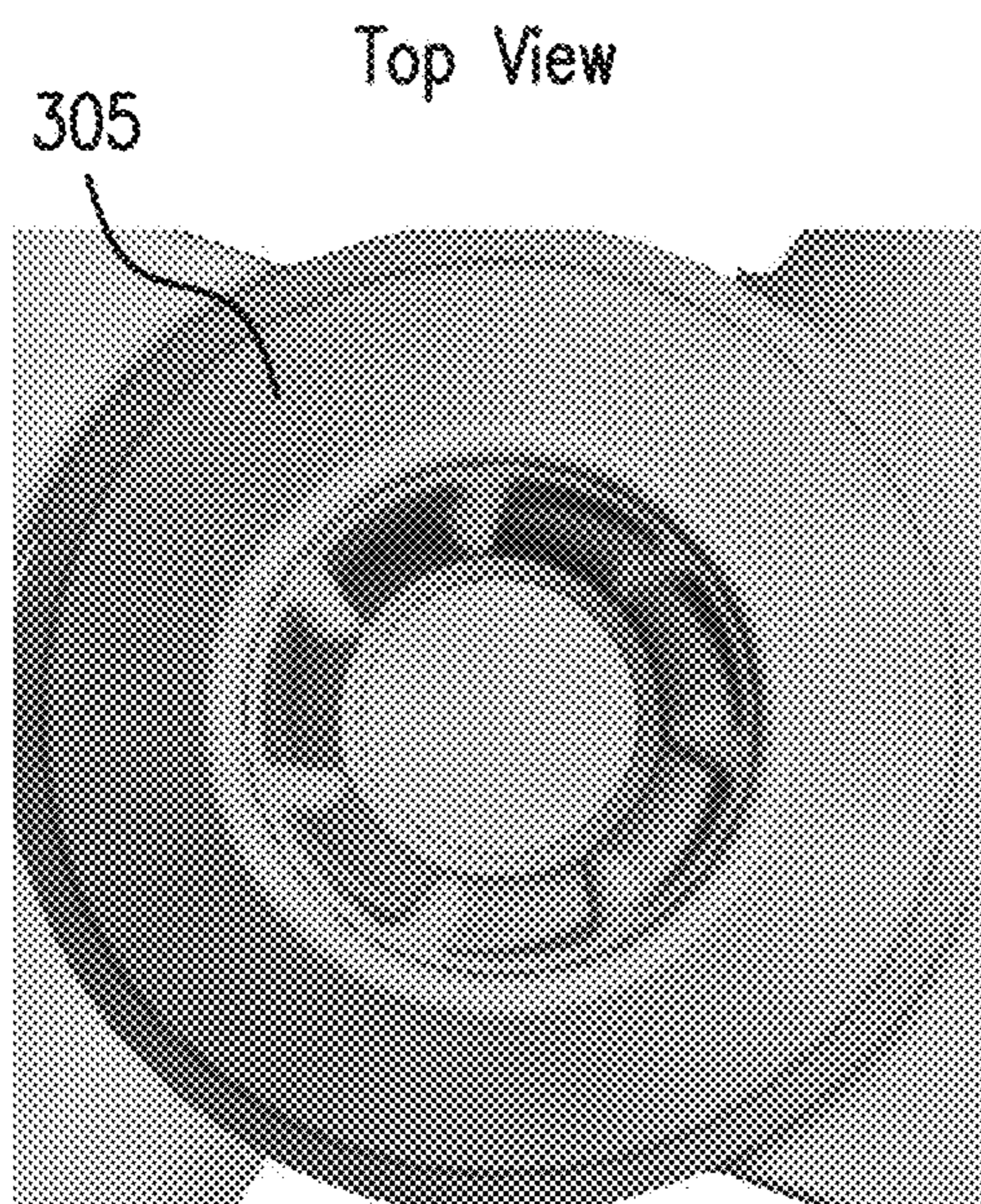

FIG. 13B

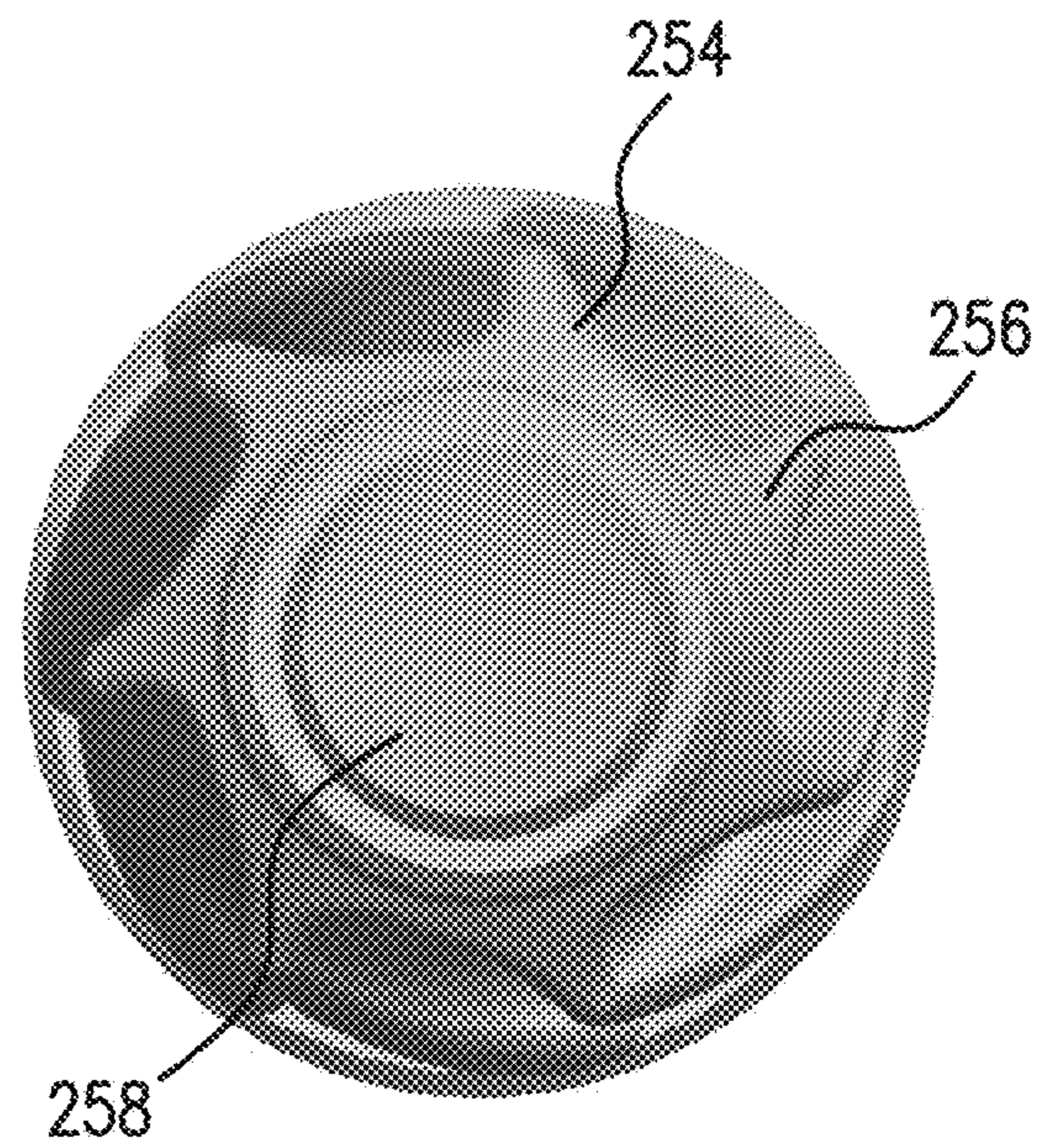
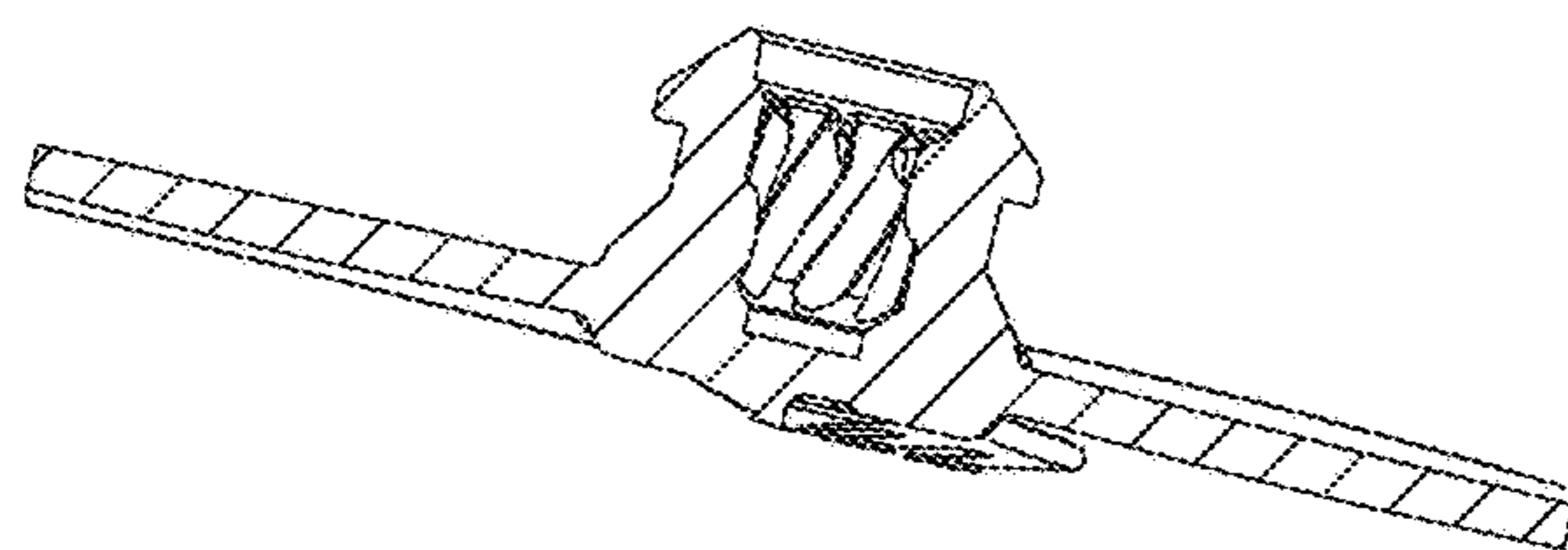

FIG. 14B



SECTION B-B
FIG. 16B

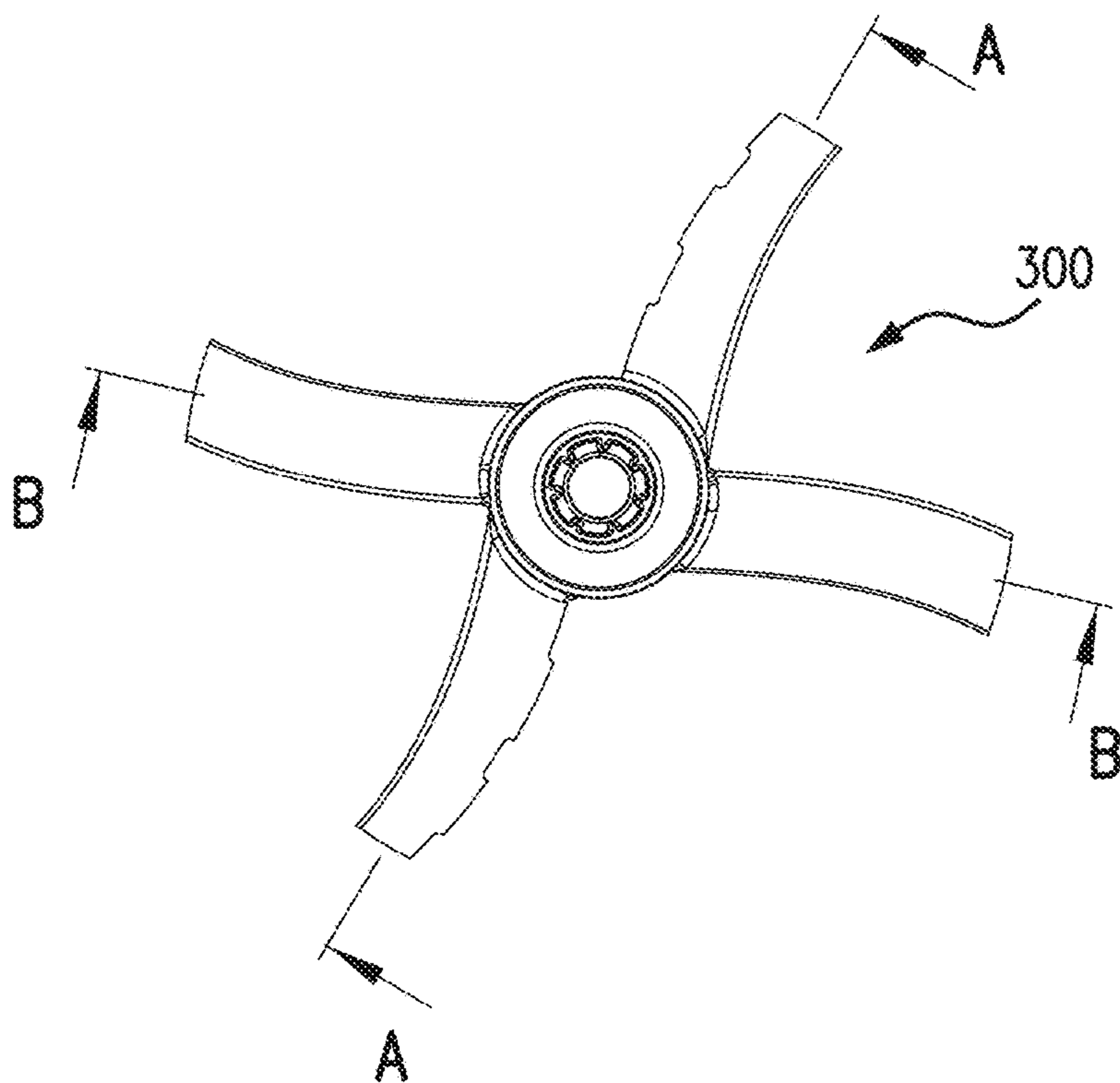
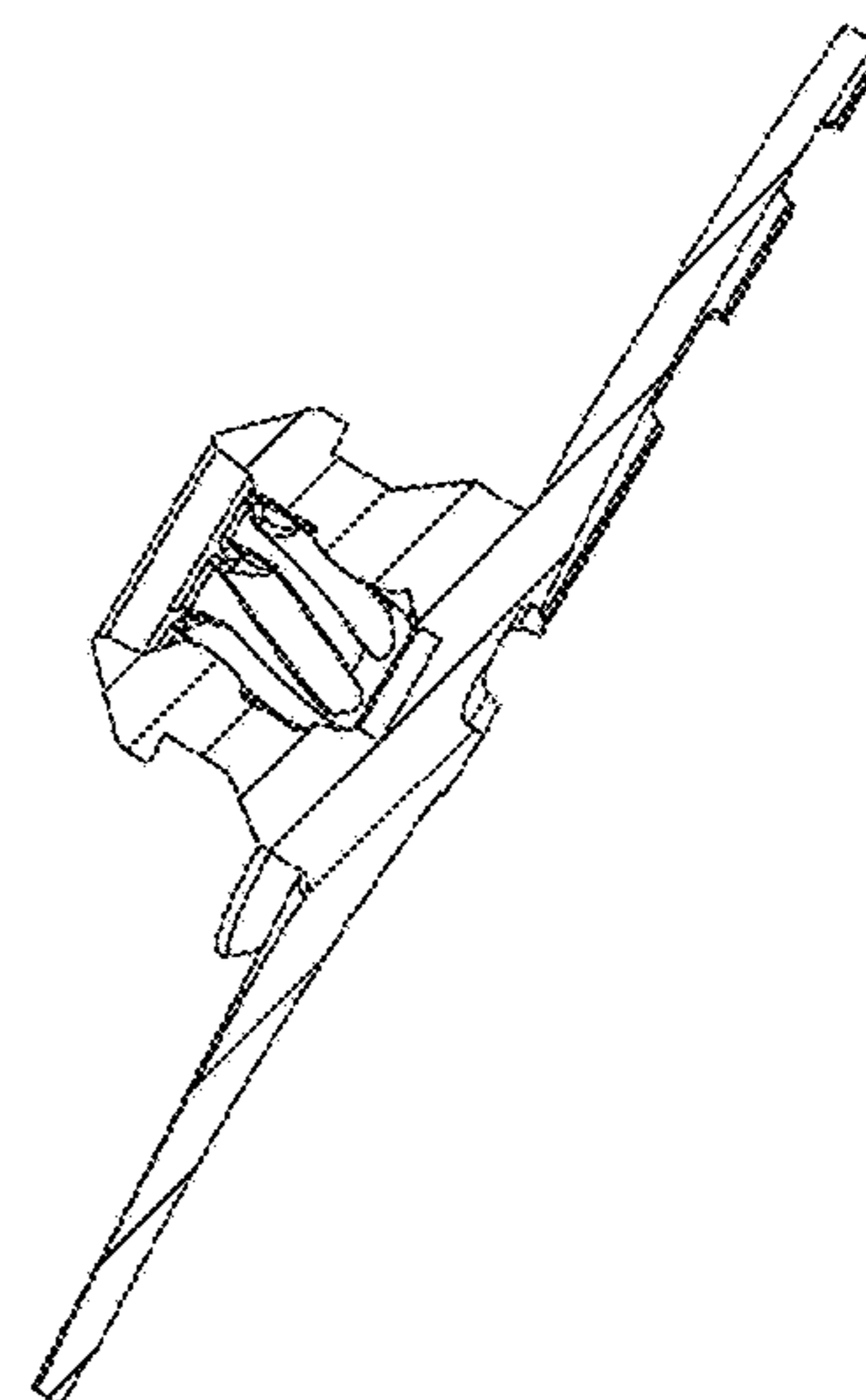

FIG. 15



SECTION A-A
FIG. 16A

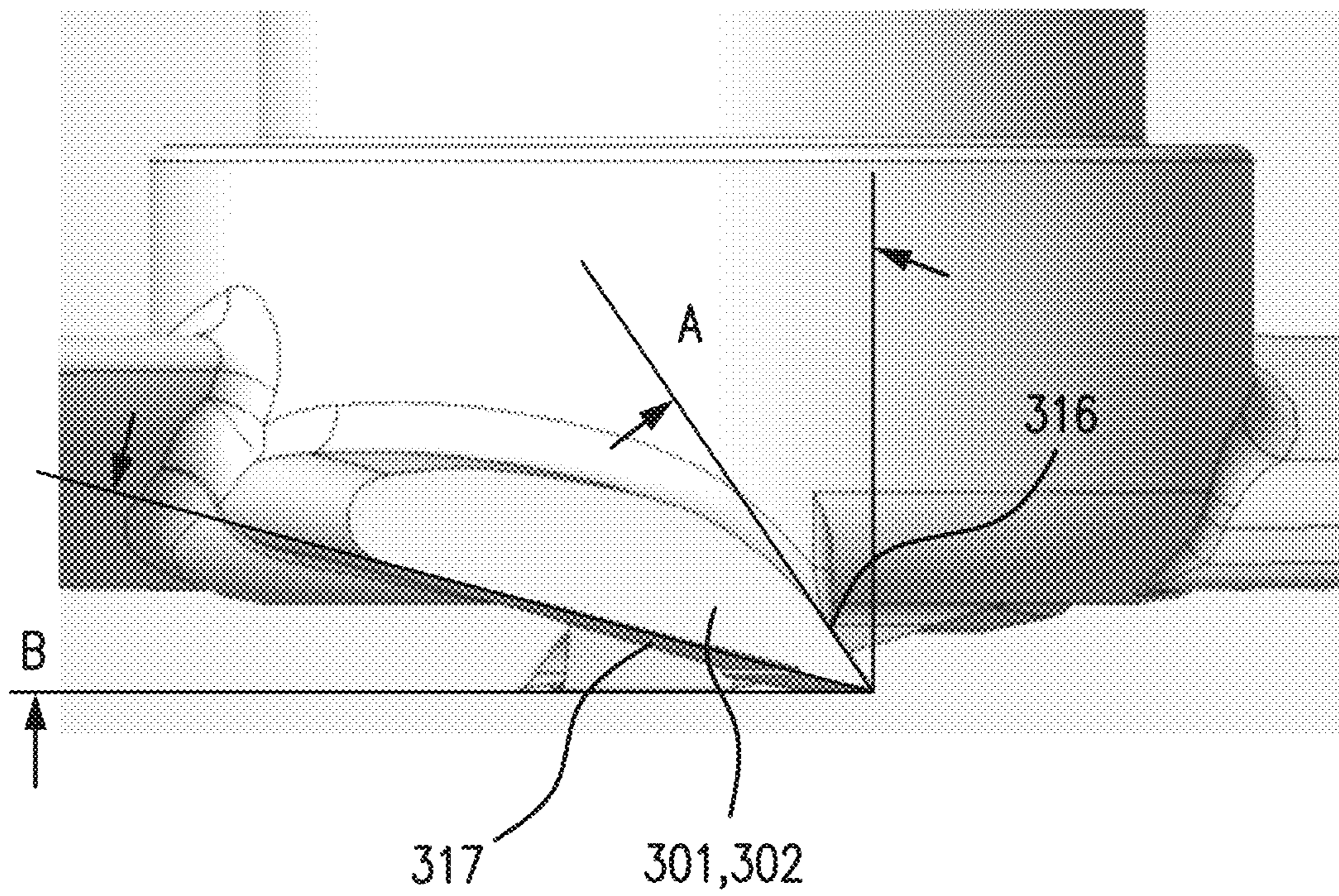

FIG. 17

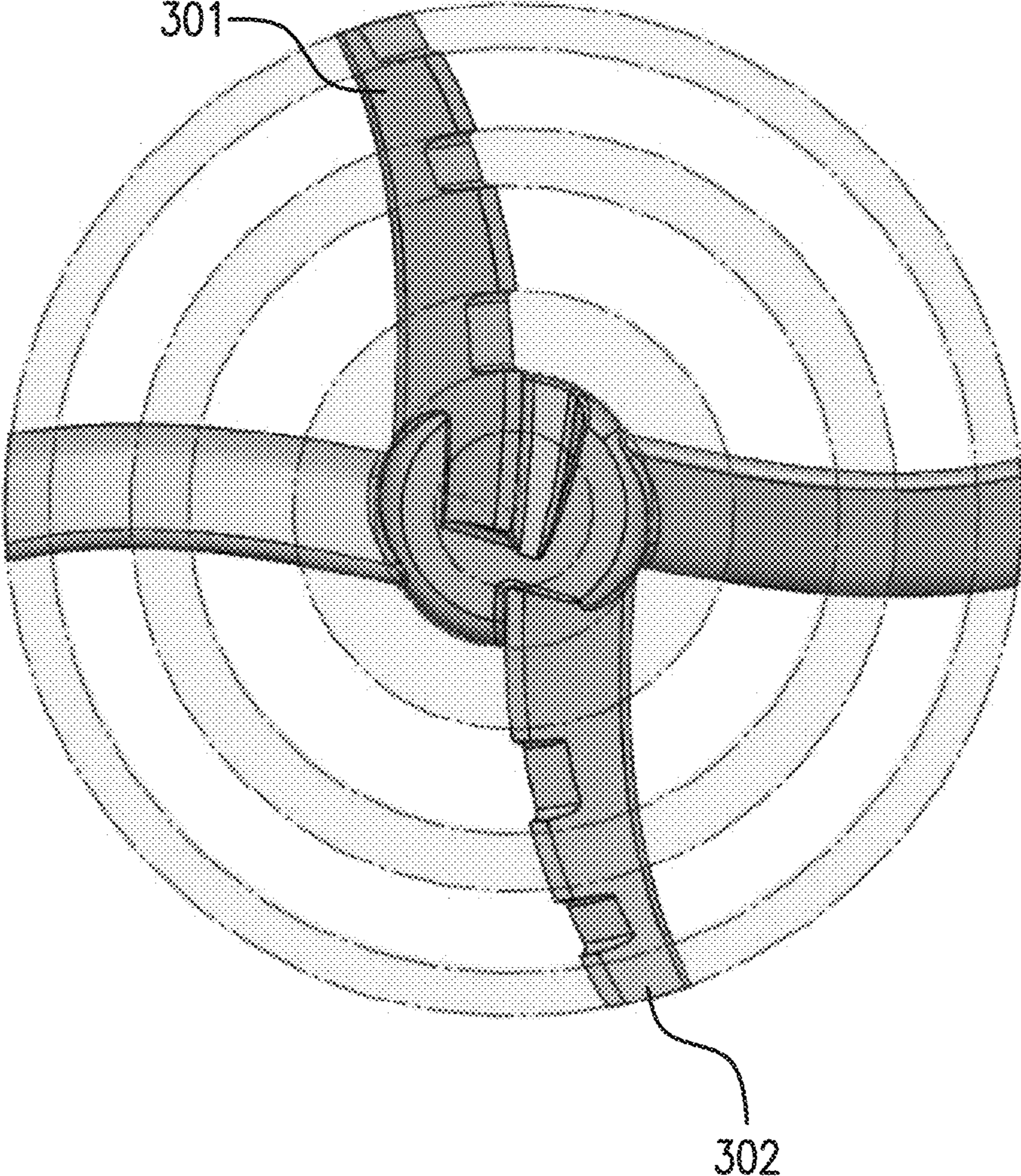

FIG. 18

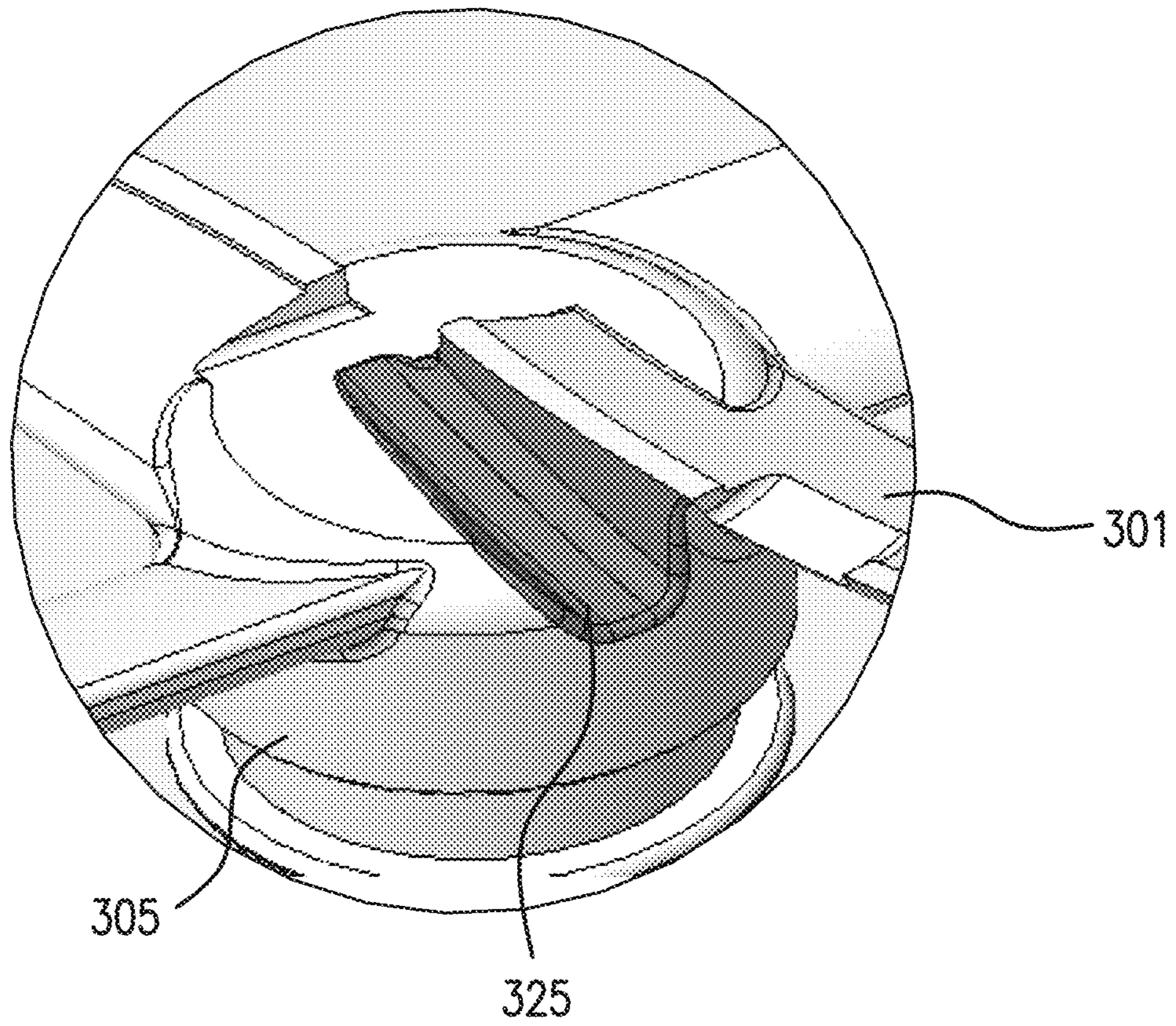

FIG. 19

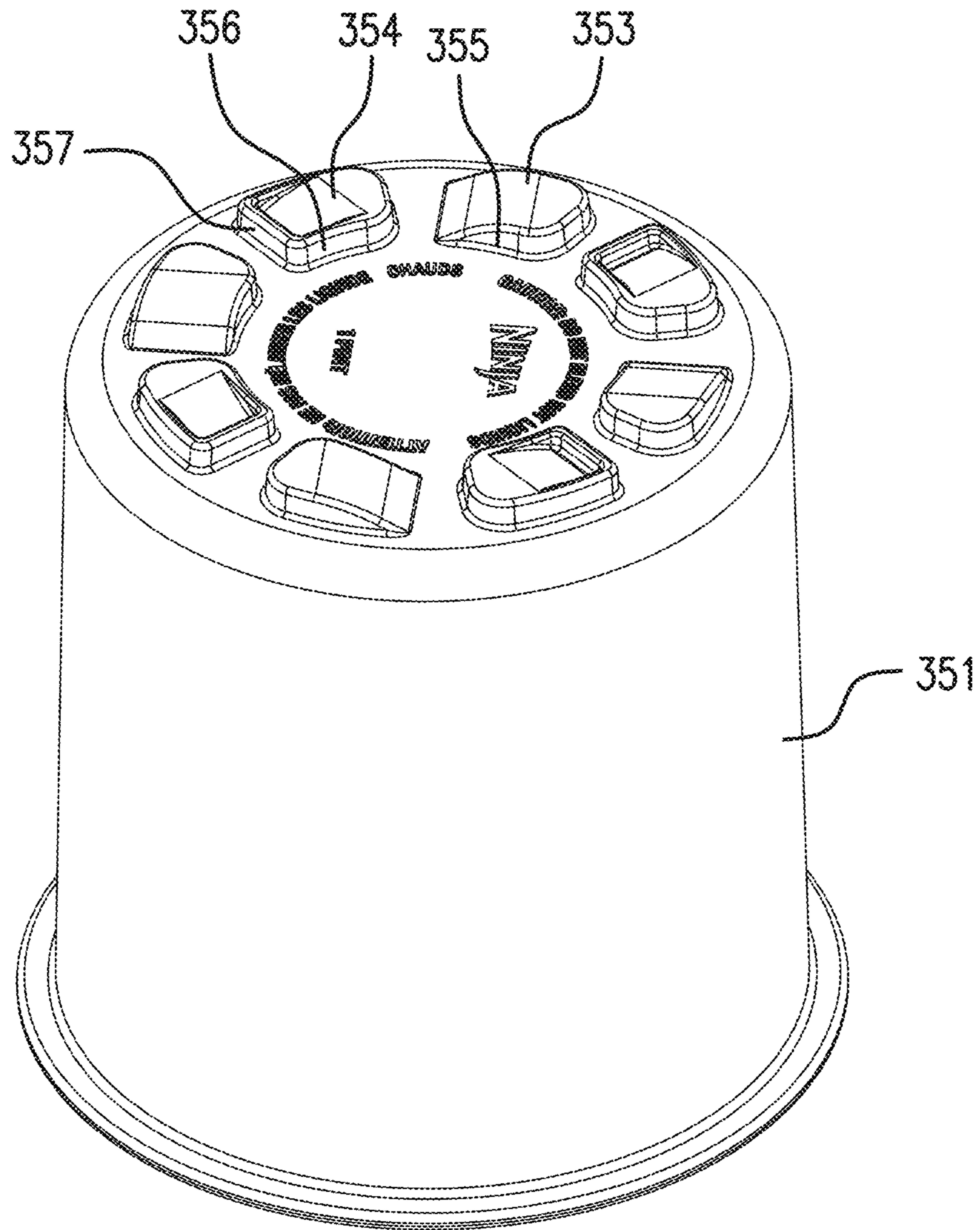

FIG. 20

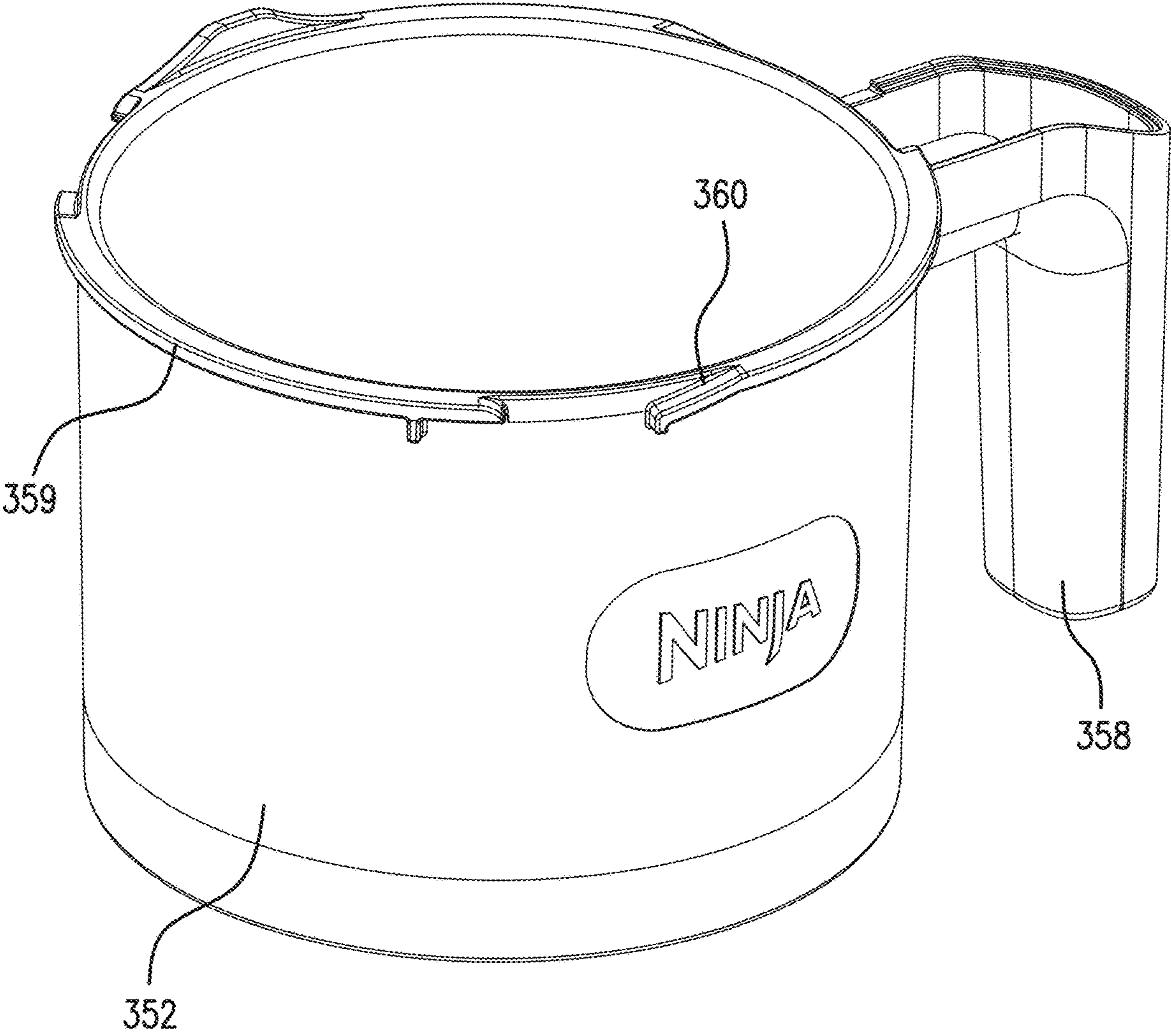

FIG. 21

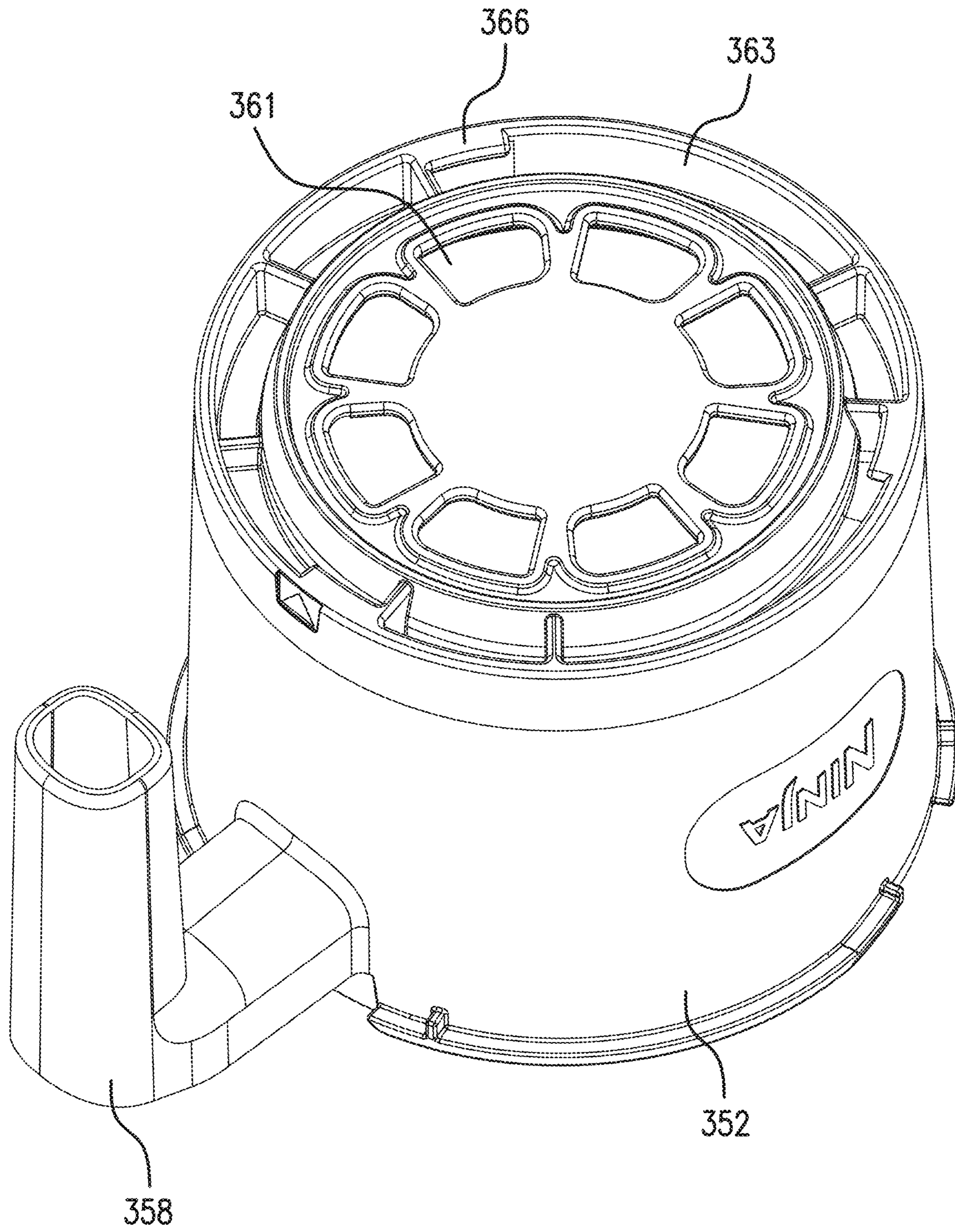

FIG. 22

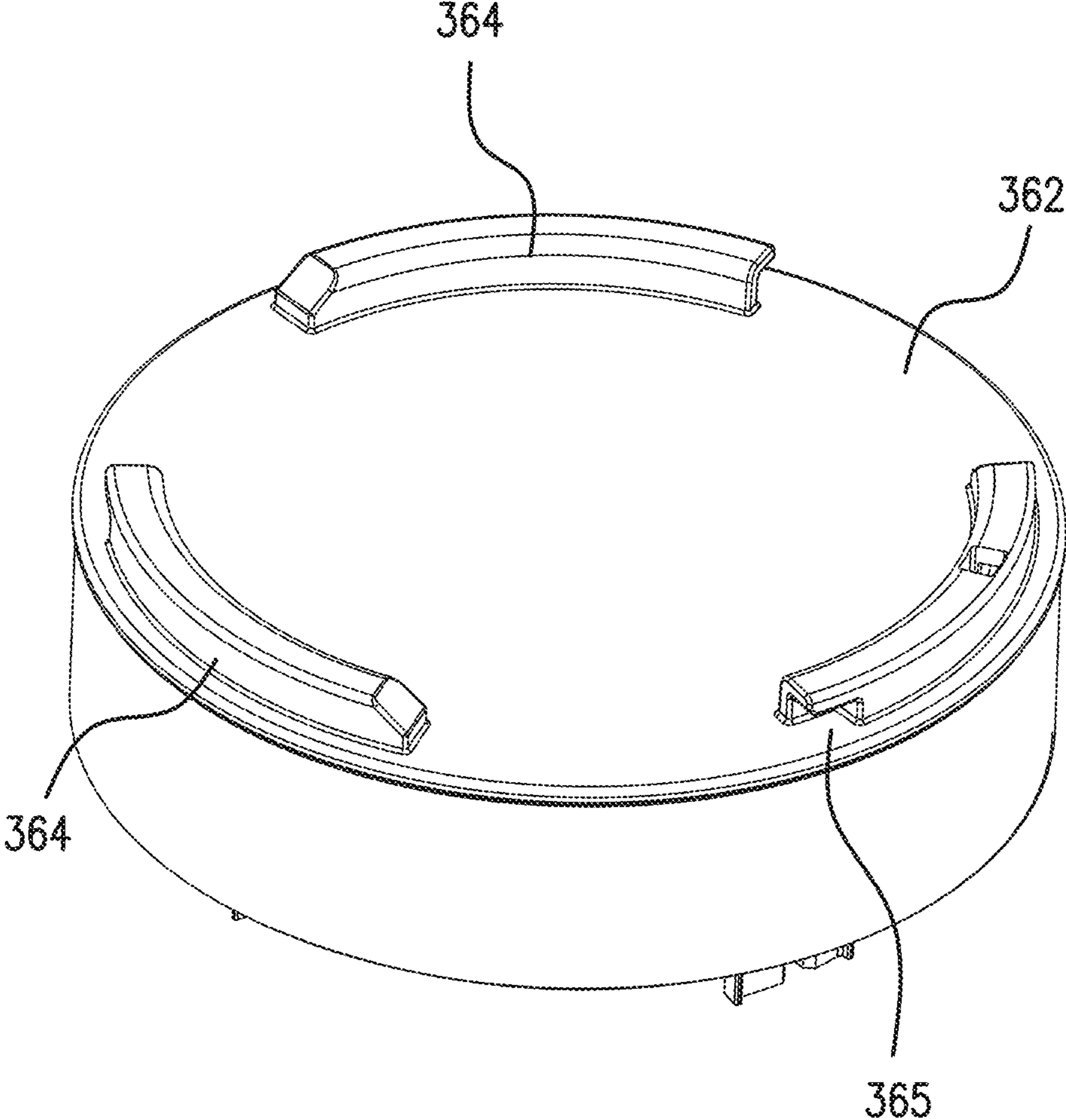

FIG. 23

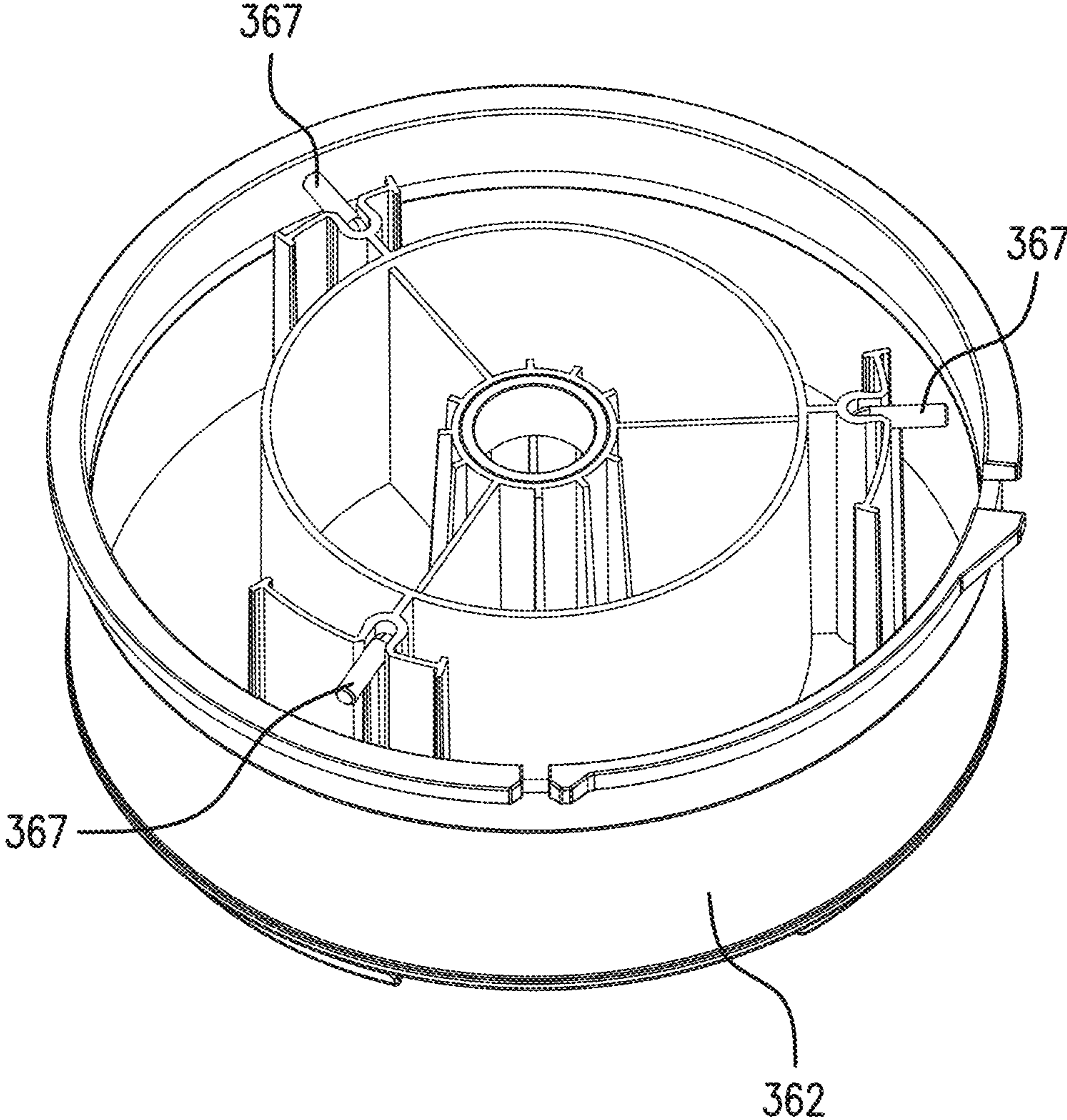

FIG. 24

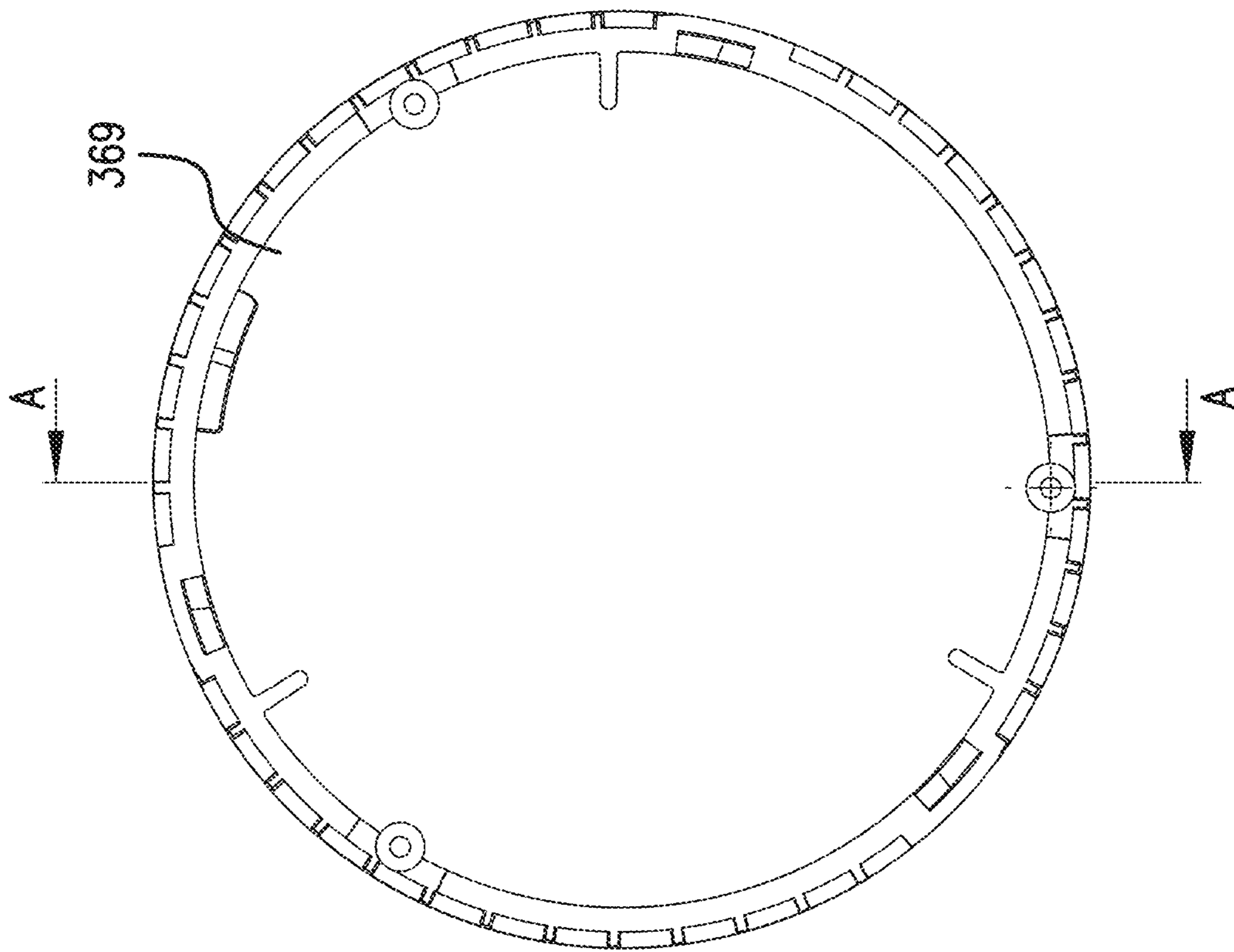
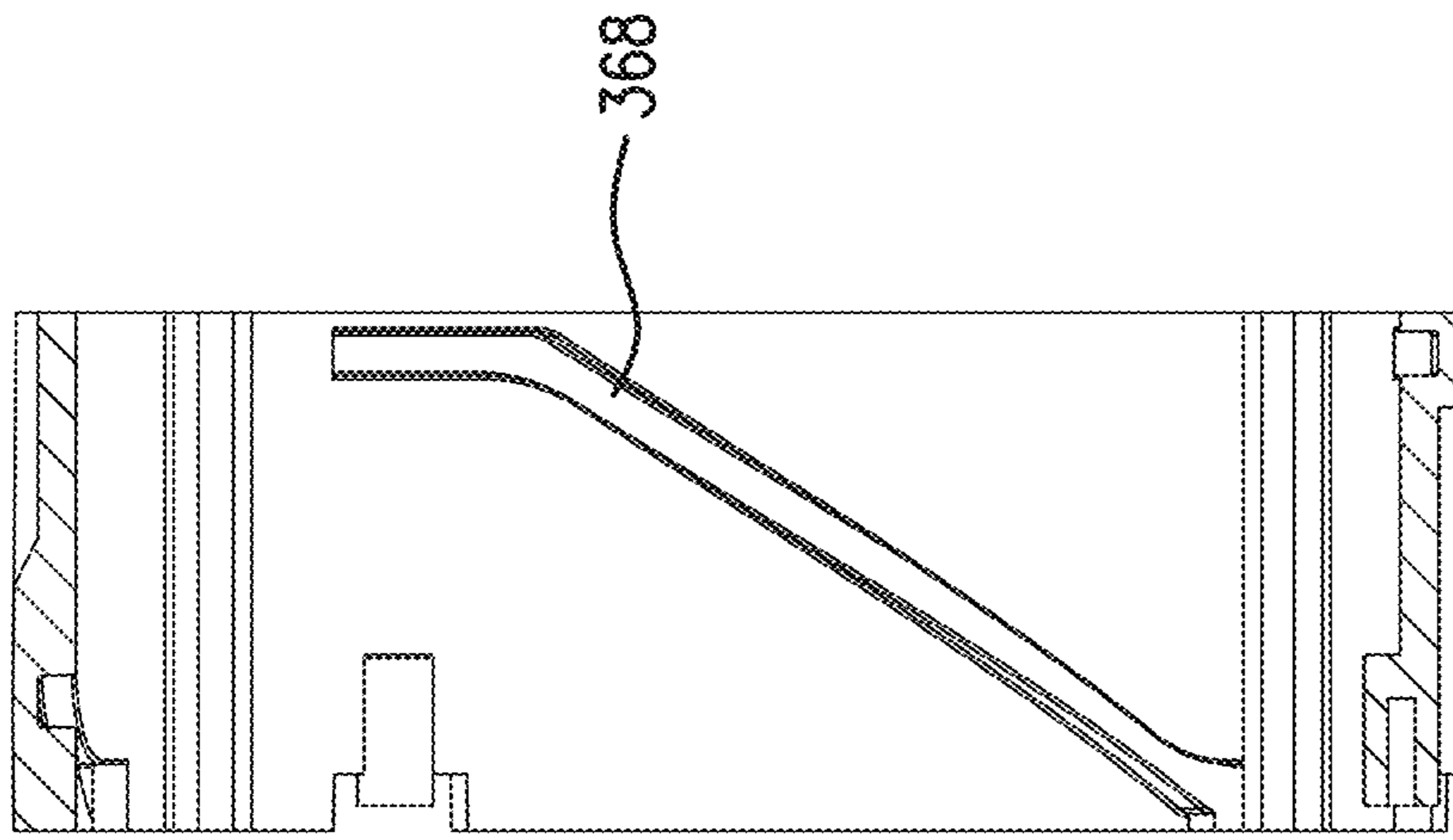

FIG. 25A



SECTION A-A

FIG. 25B

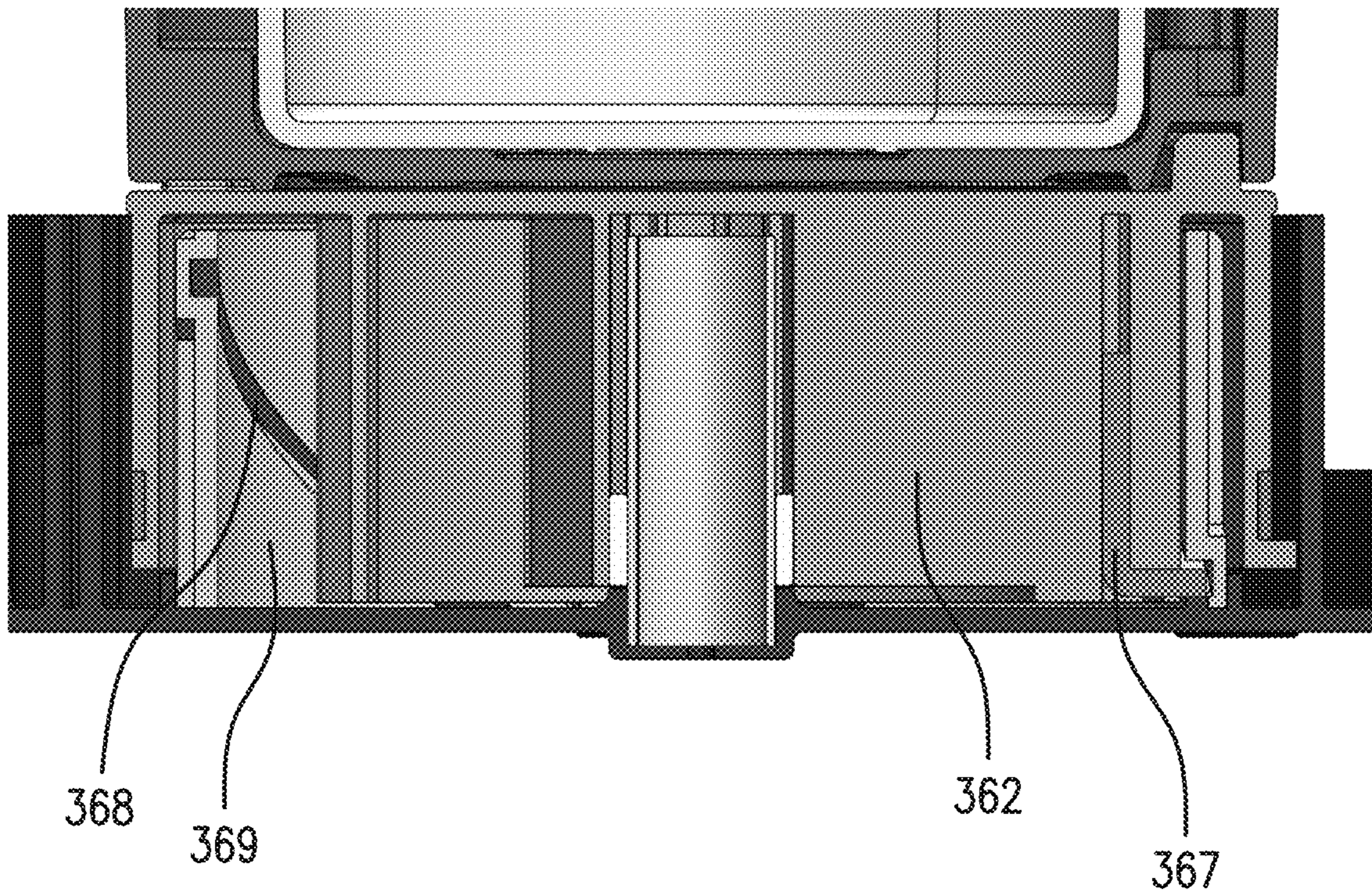

FIG. 26

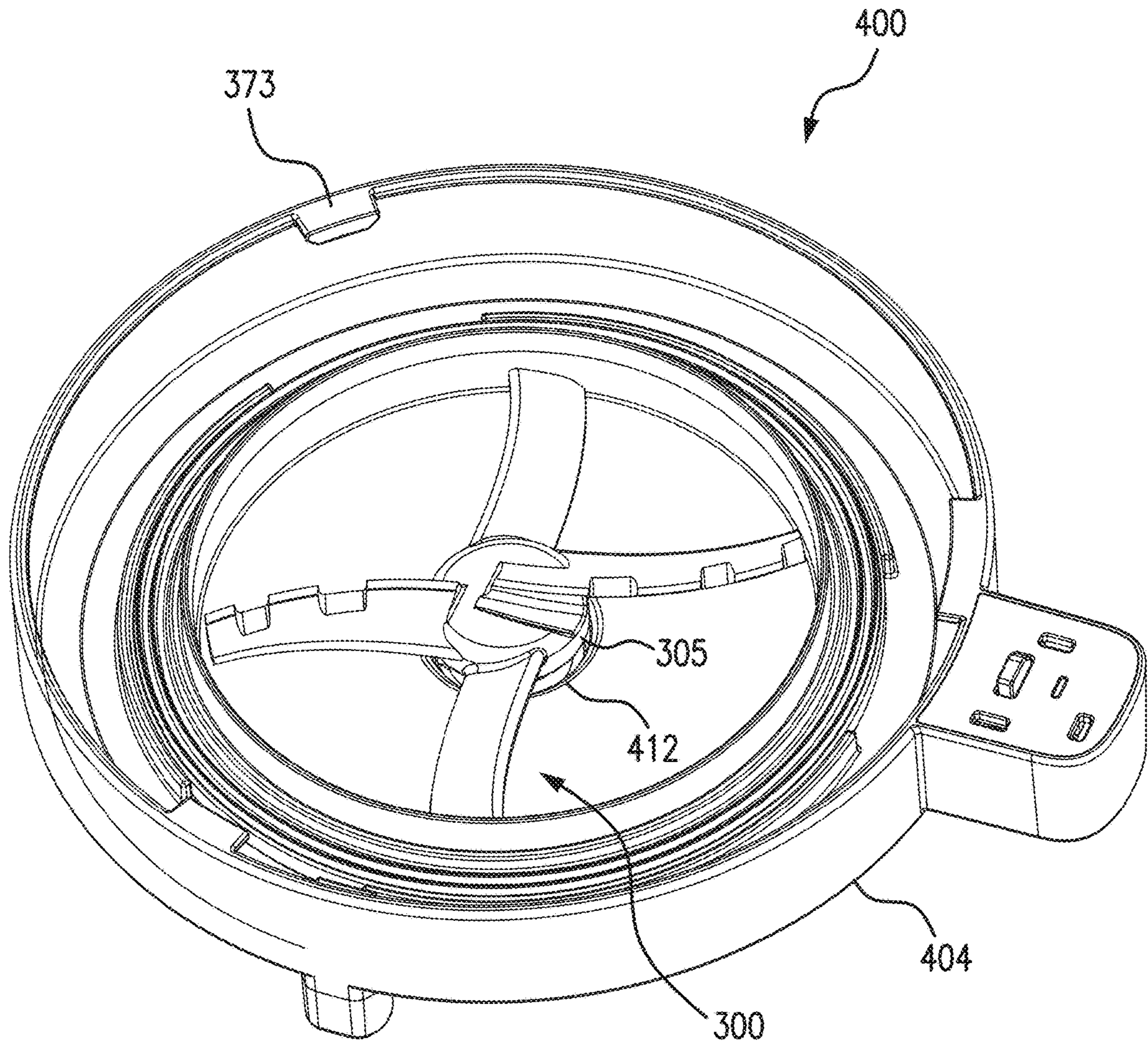

FIG. 27

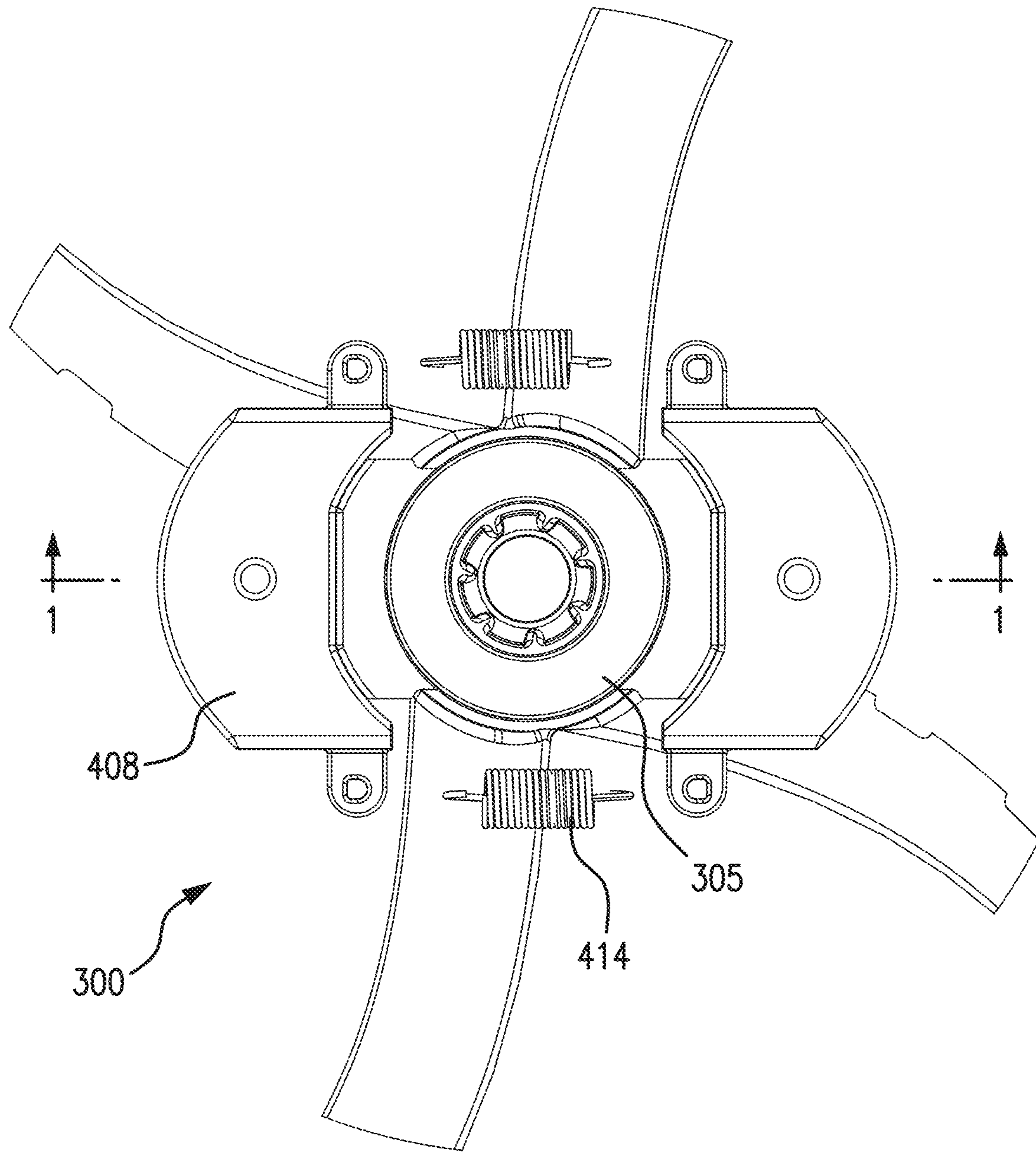

FIG. 28

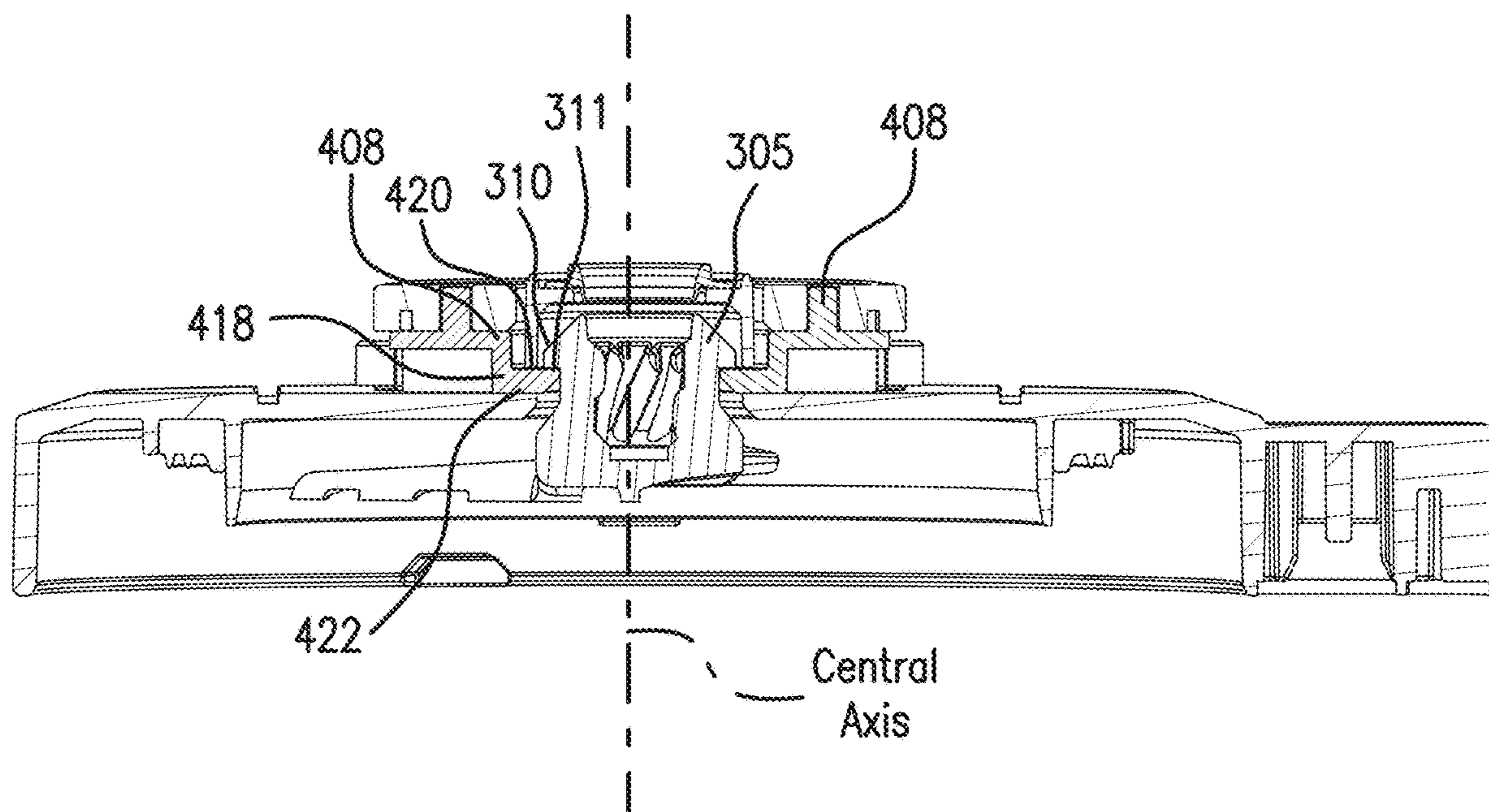

FIG. 29

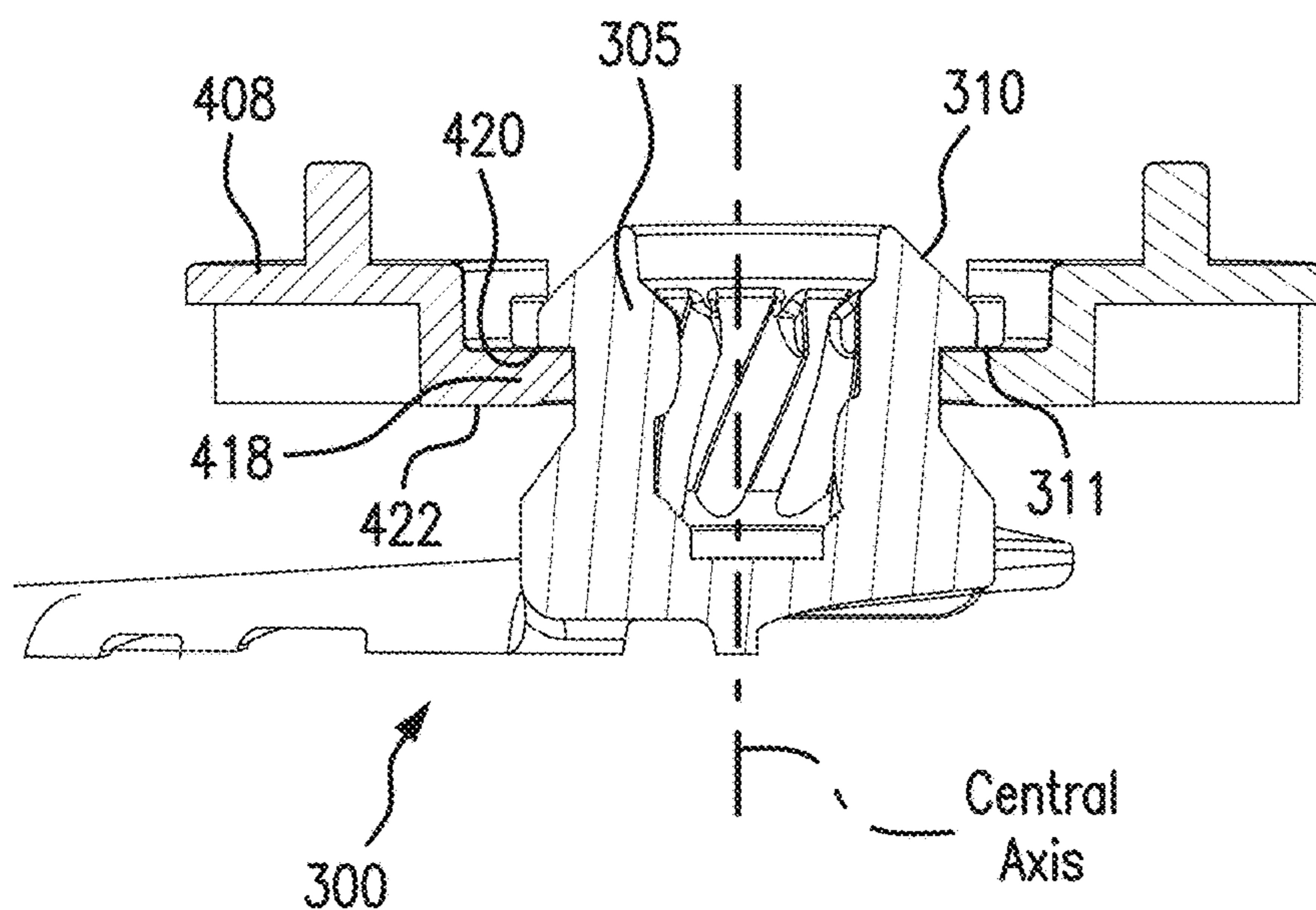

FIG. 30

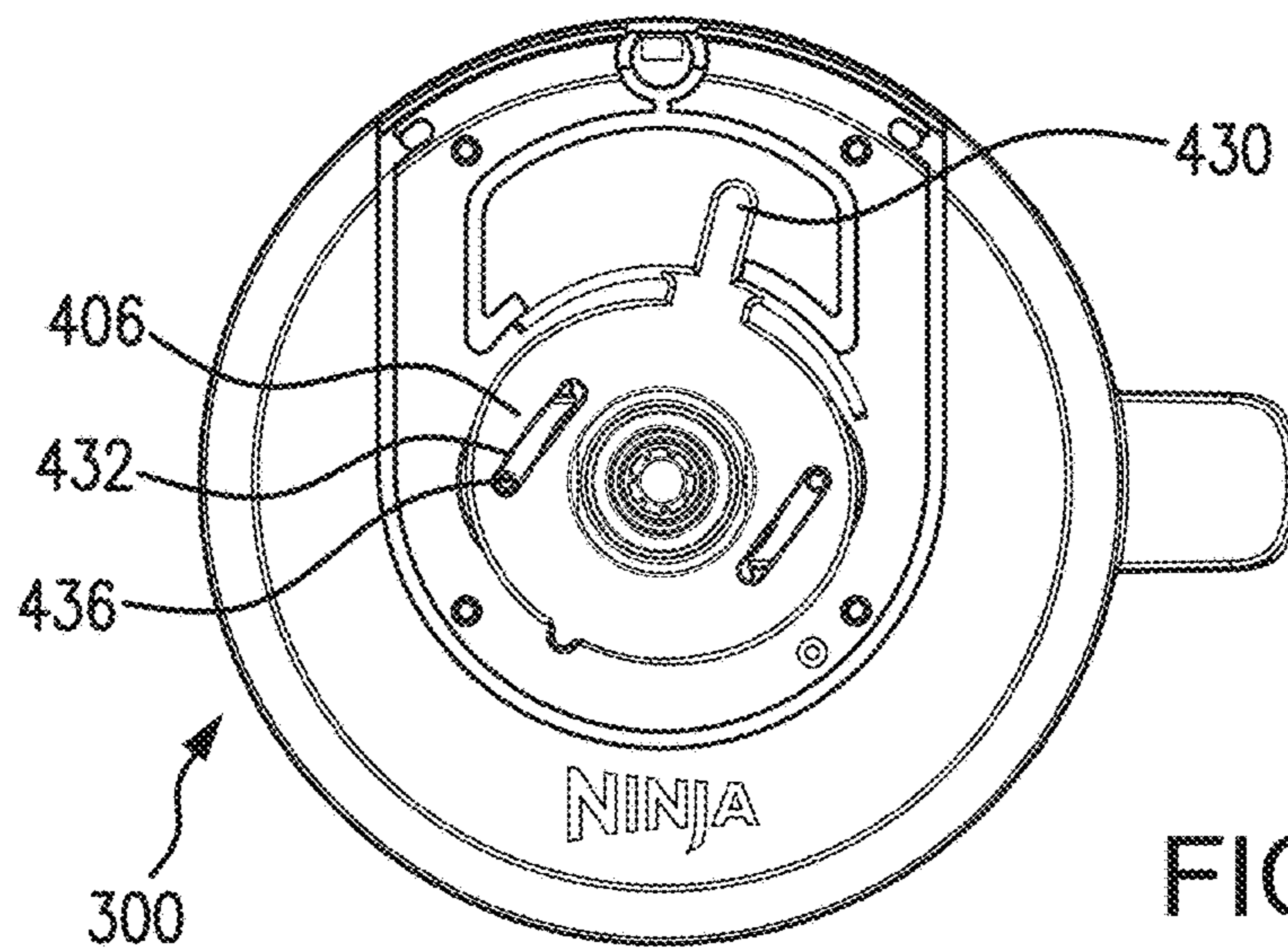

FIG. 31C

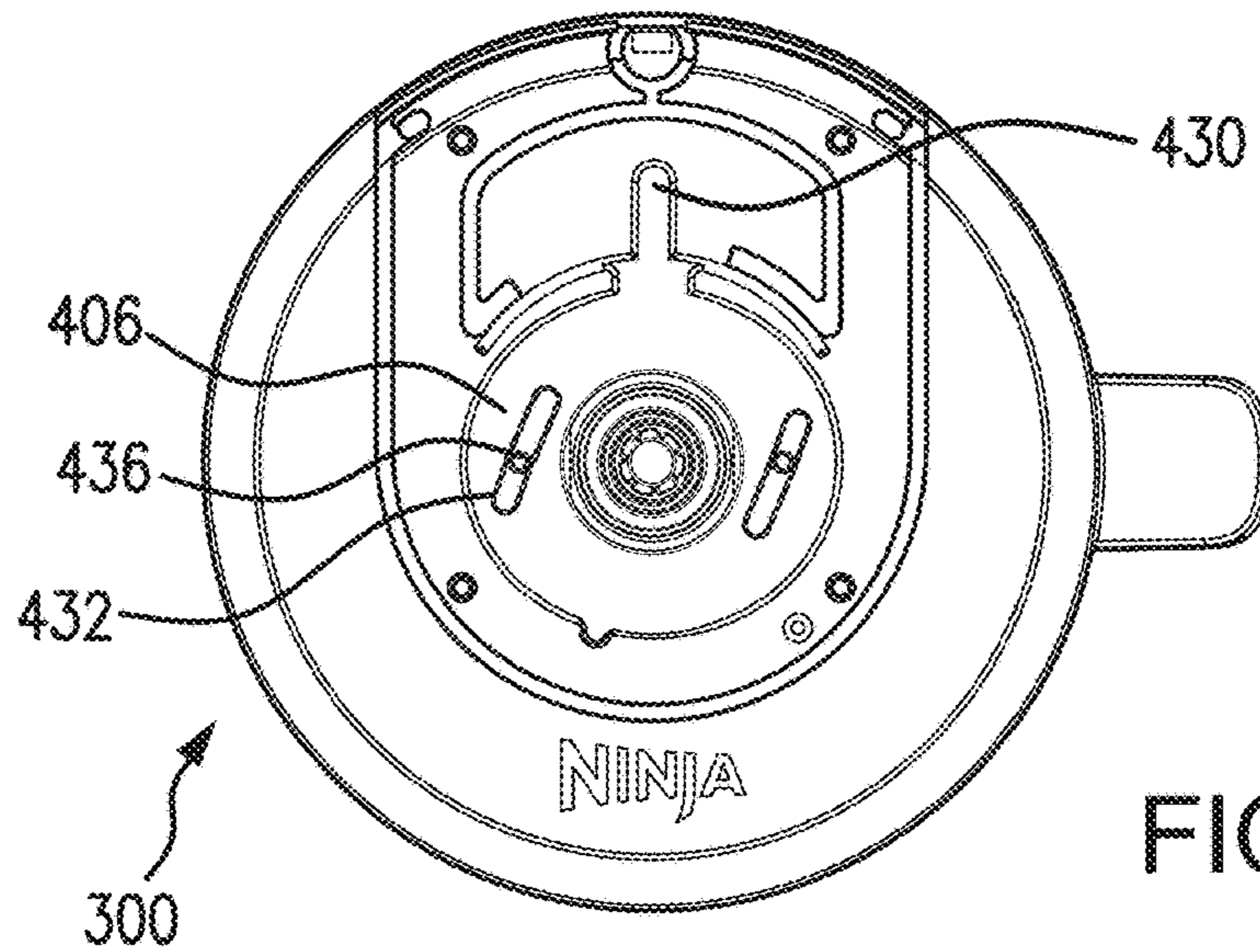

FIG. 31B

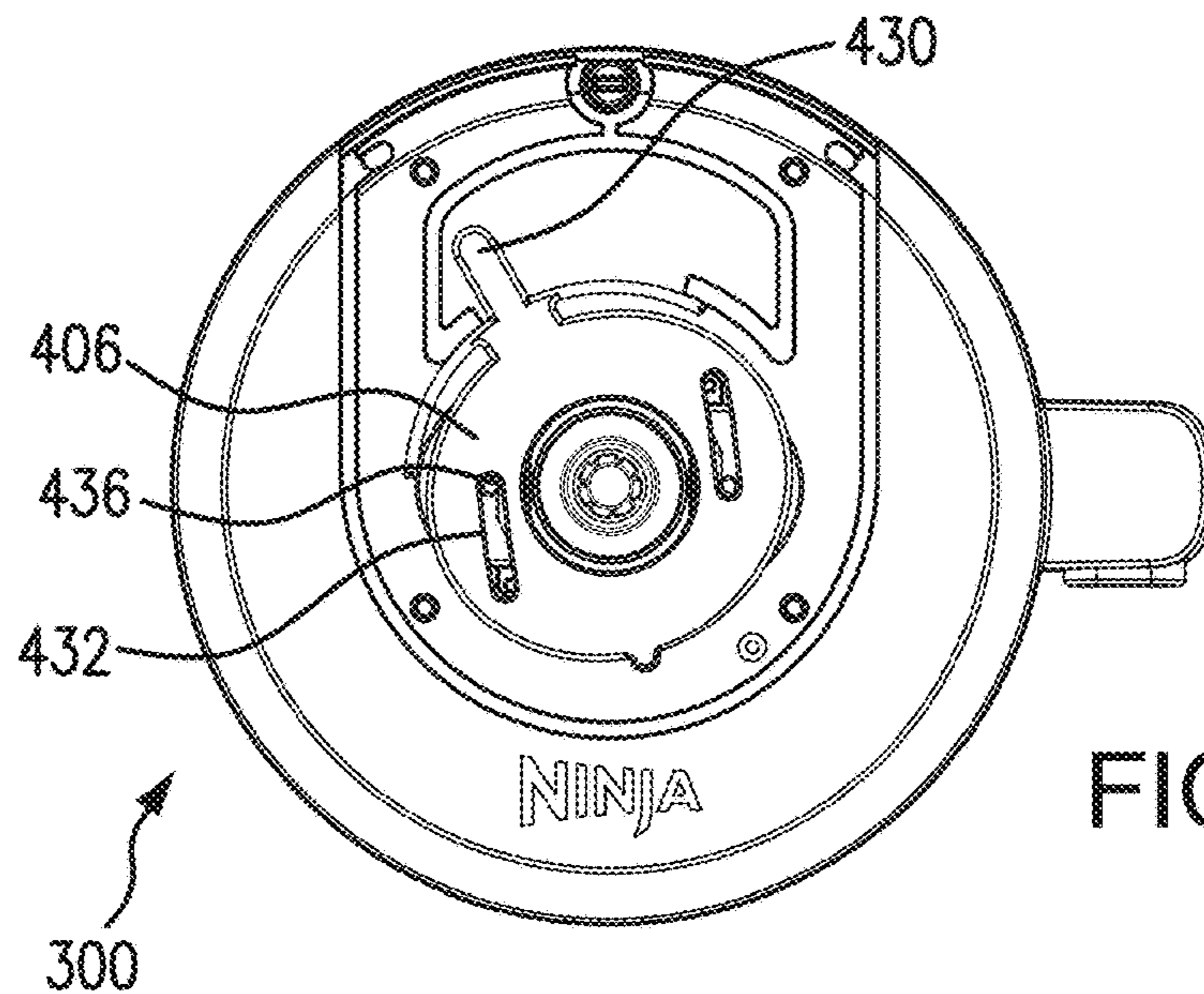

FIG. 31A

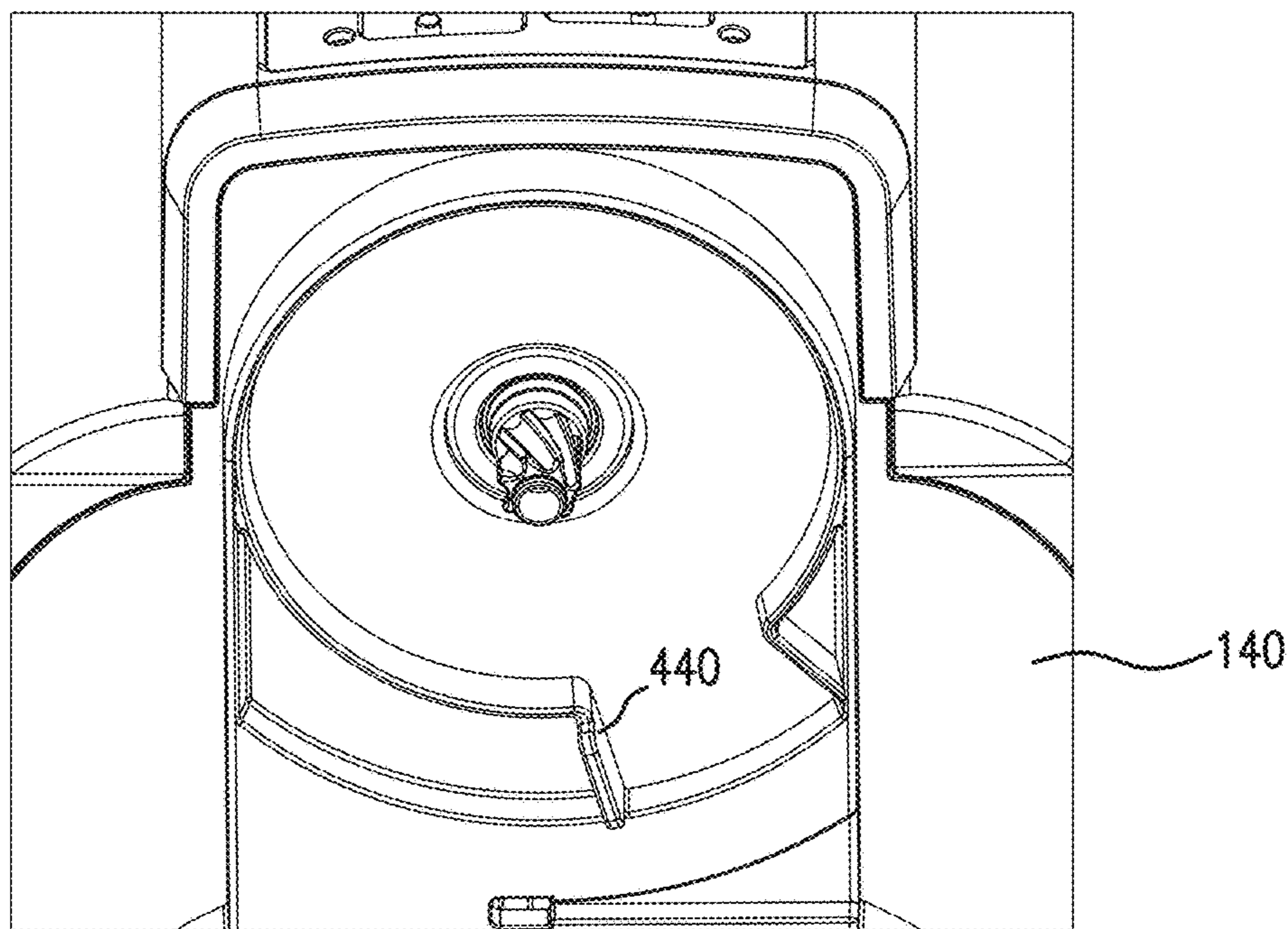

FIG. 32

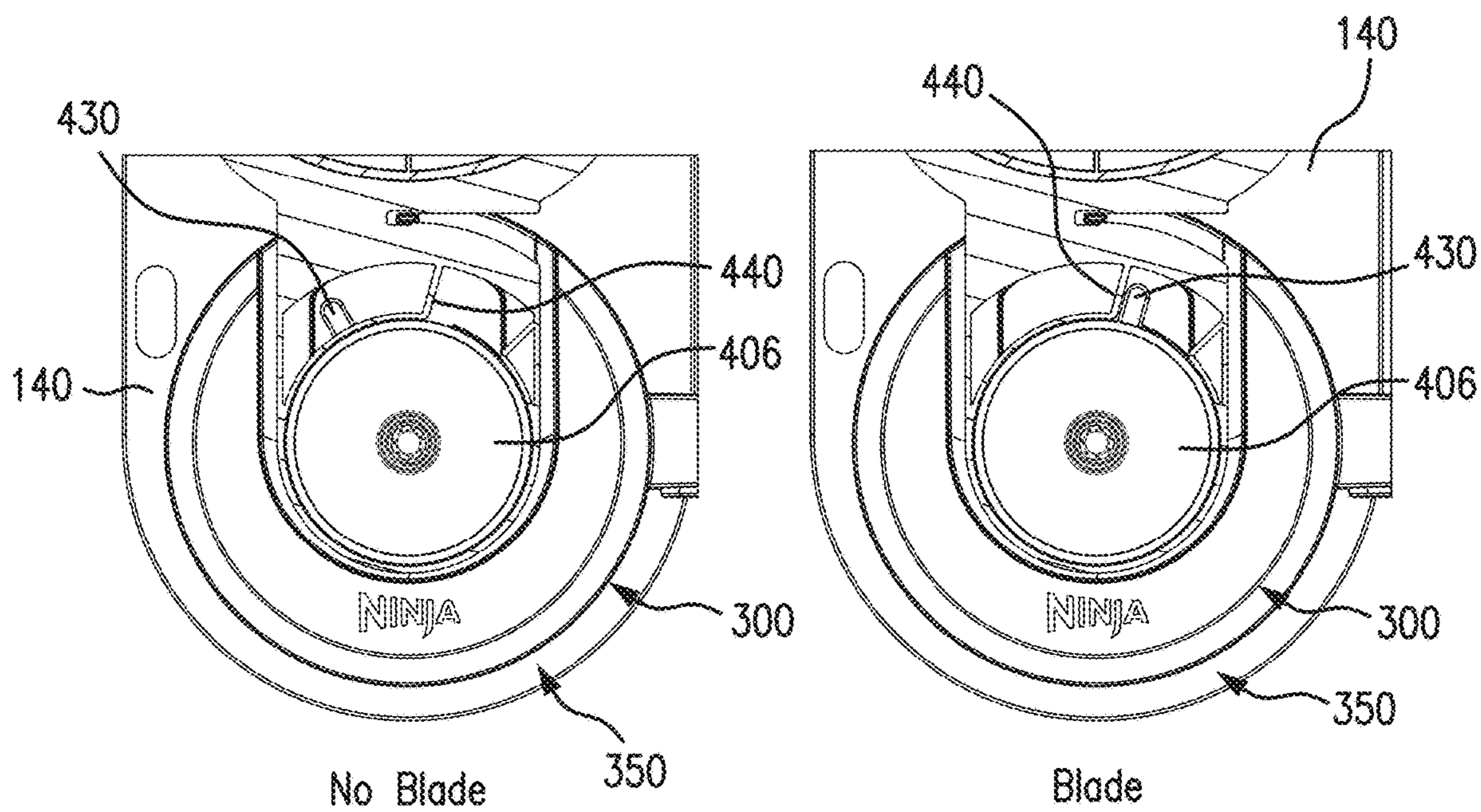

FIG. 33A

FIG. 33B

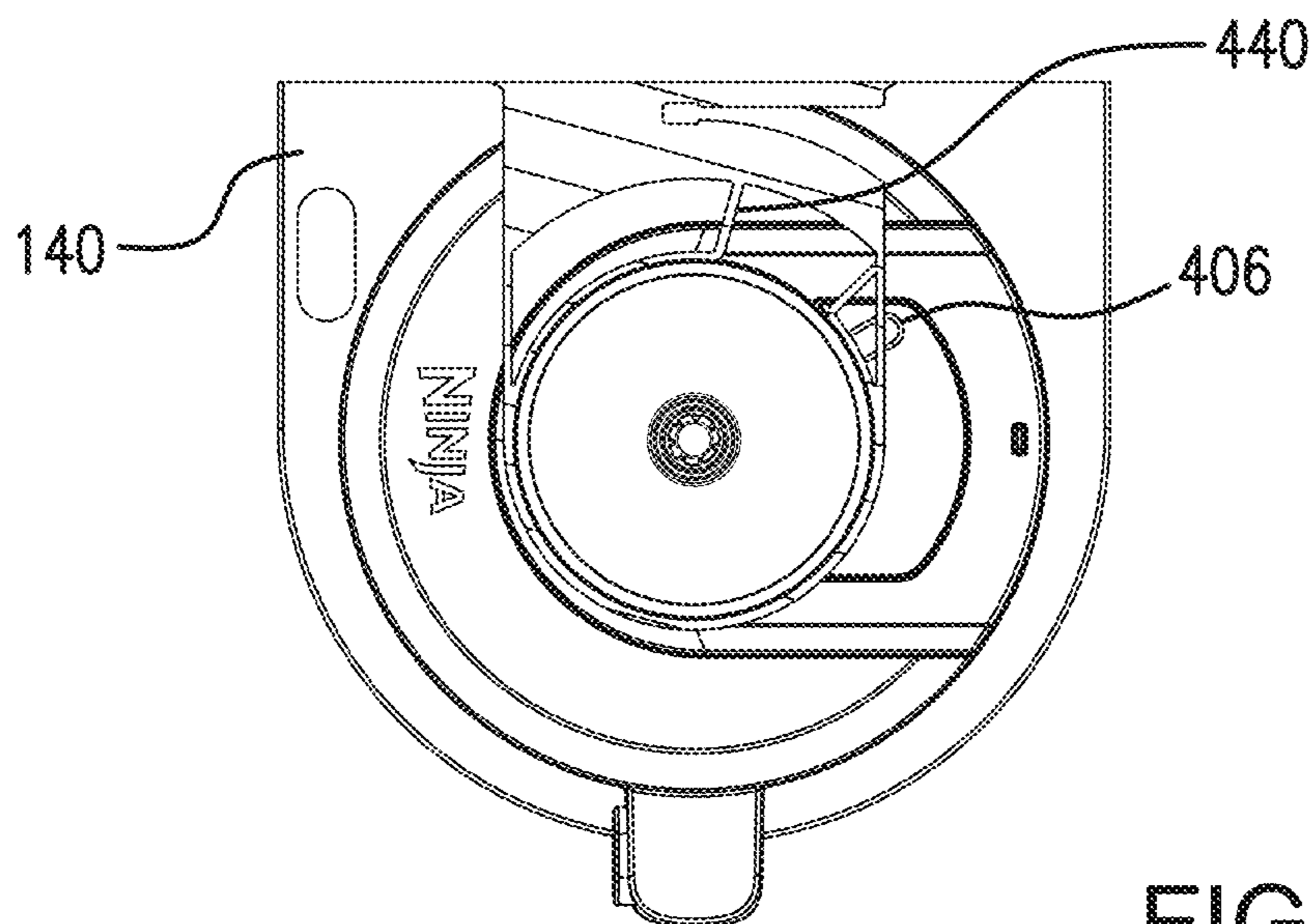

FIG. 34A

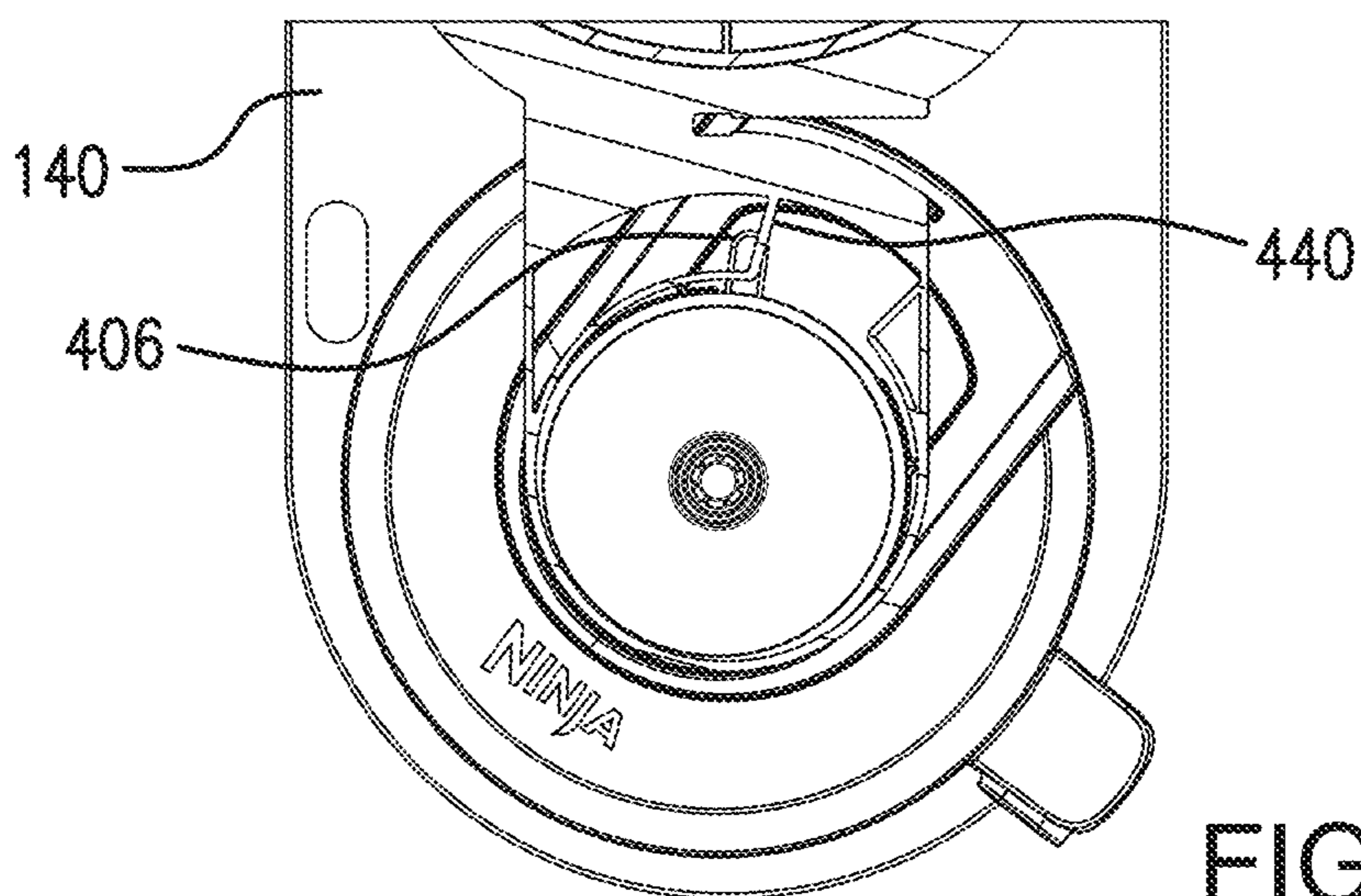

FIG. 34B

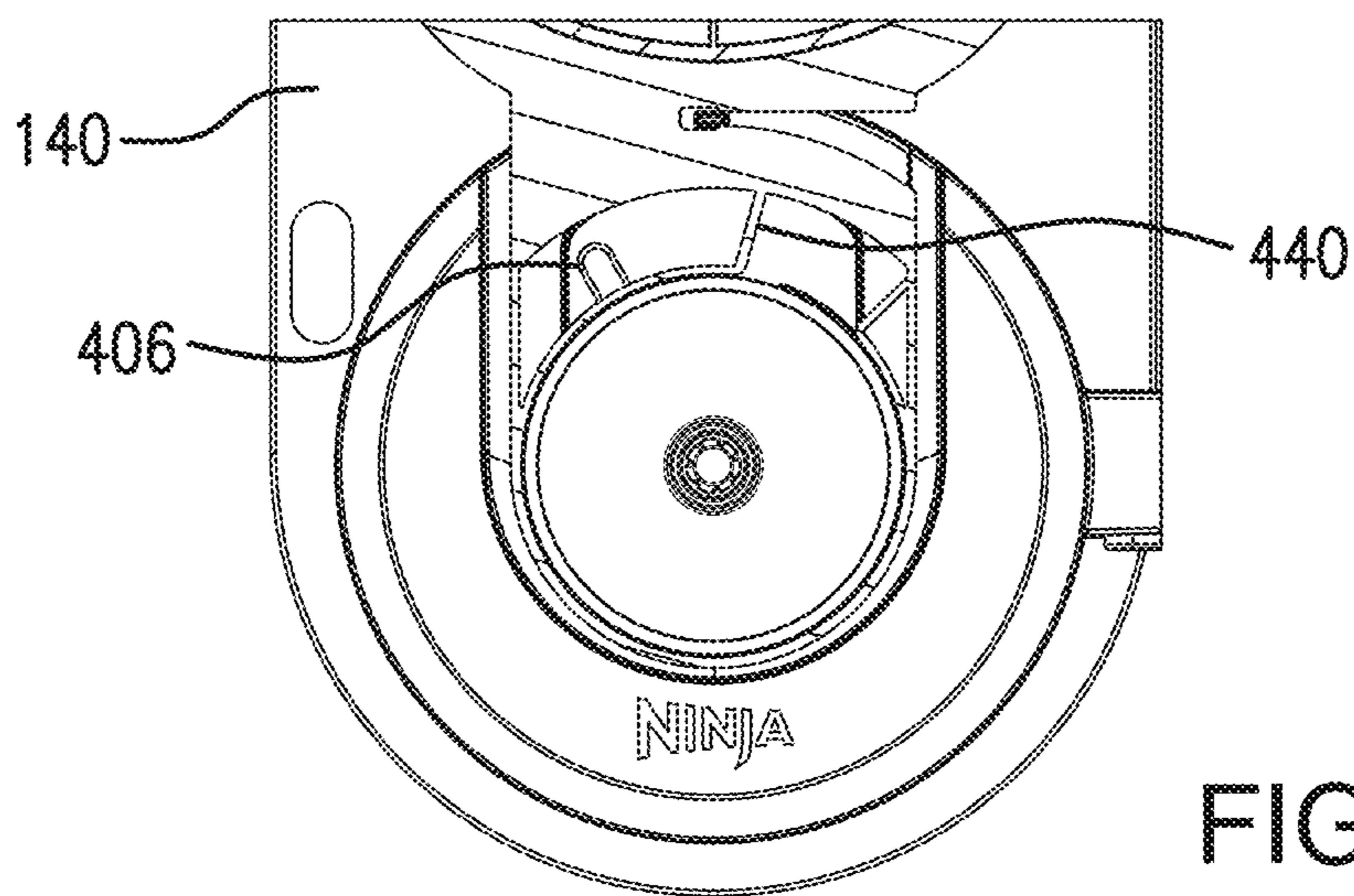

FIG. 34C

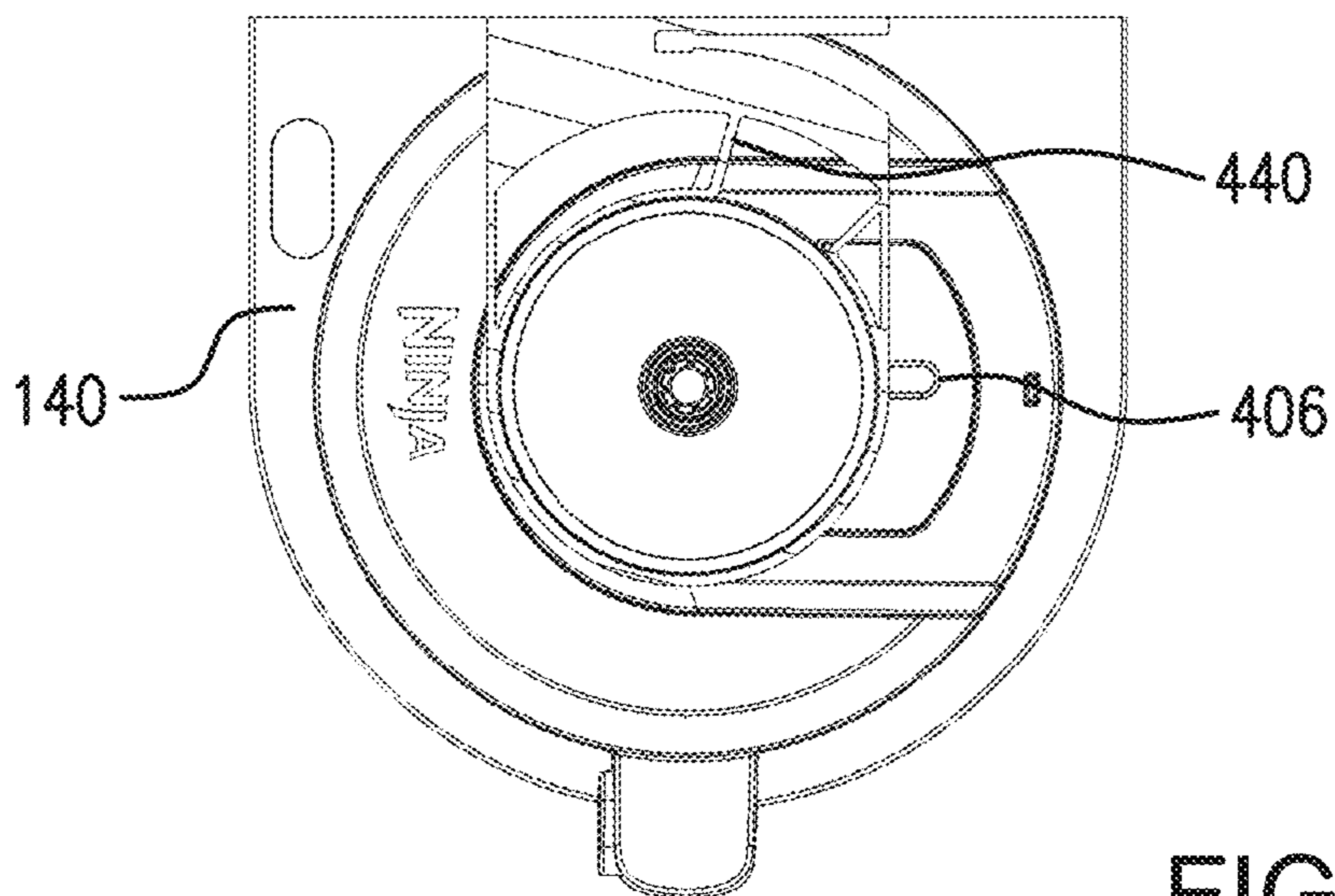

FIG. 35A

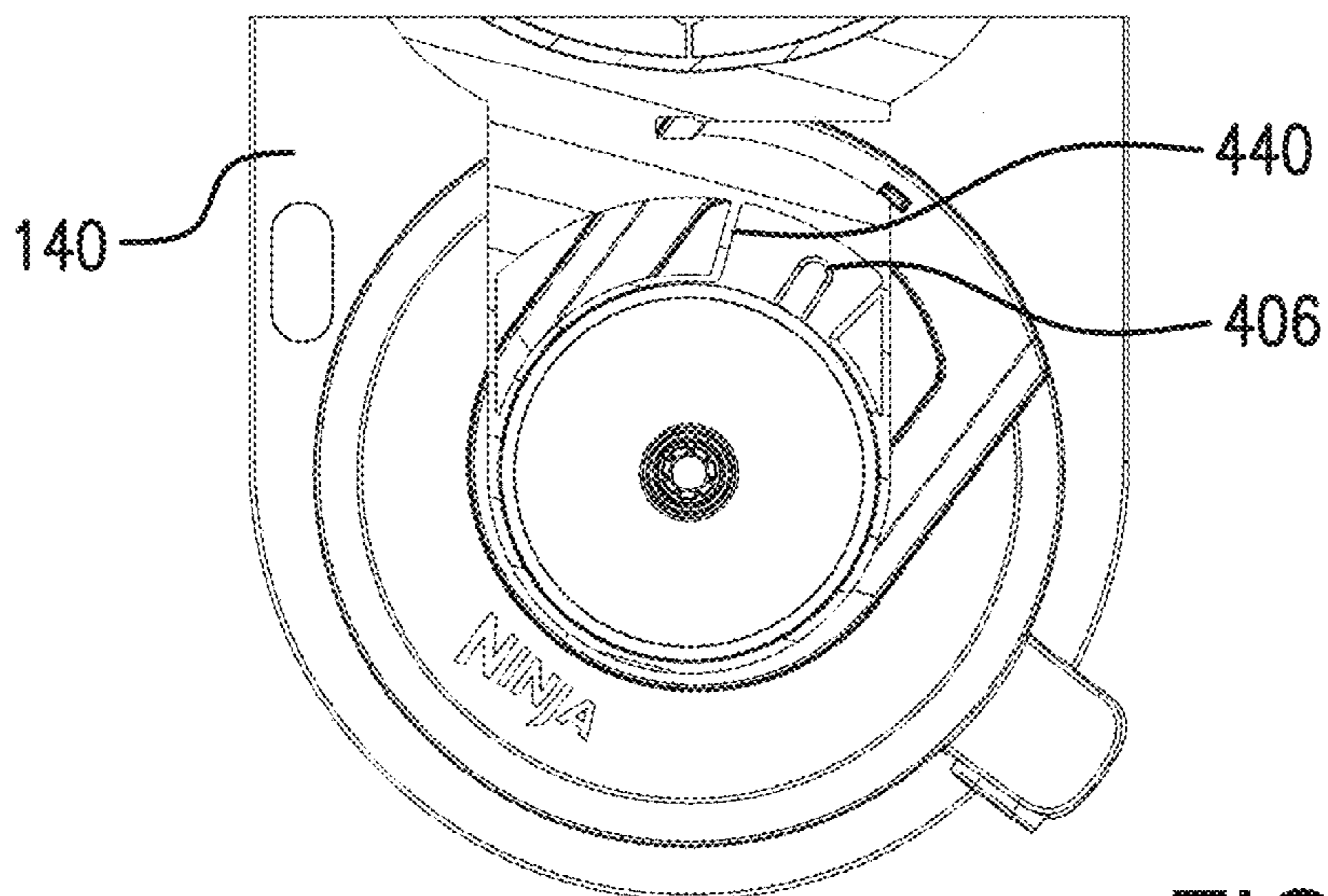

FIG. 35B

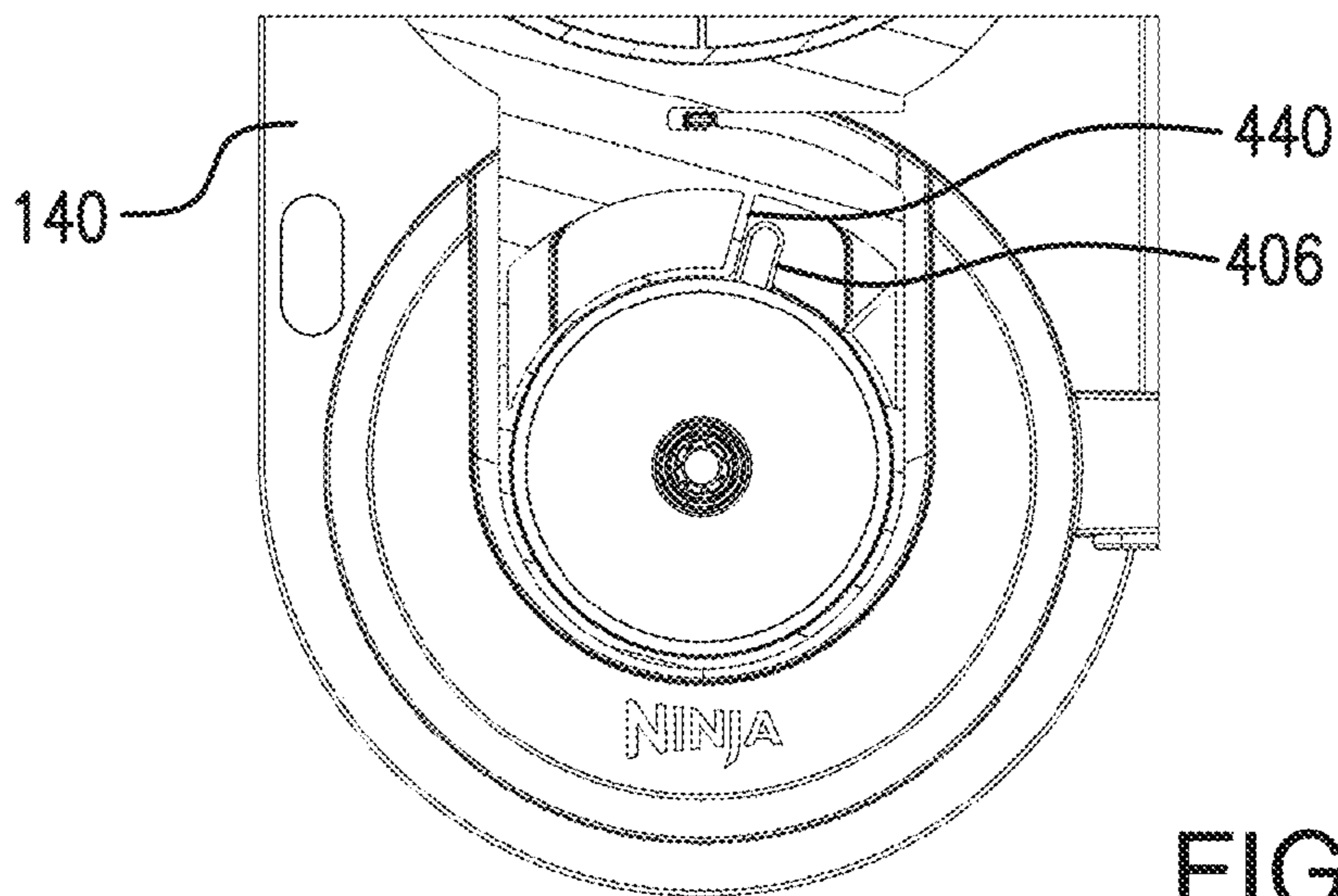

FIG. 35C

1**MICRO PUREE MACHINE**

FIELD OF THE INVENTION

The present disclosure relates to a kitchen and food processing device, and more particularly, to a device and system for micro pureeing frozen ingredients to make frozen foods and drinks.

BACKGROUND

Home use machines that are intended to make ice creams, gelatos, frozen yogurts, sorbets and the like are known in the art. Typically, a user adds a series of non-frozen ingredients to a bowl. The ingredients are then churned by a paddle while a refrigeration mechanism simultaneously freezes the ingredients. These devices have known shortcomings including, but not limited to, the amount of time and effort required by the user to complete the ice cream making process. Machines of this nature are impractical for preparing most non-dessert food products.

An alternative type of machine known to make a frozen food product is a micro-puree machine. Typically, machines of this nature spin and plunge a blade into a pre-frozen ingredient or combination of ingredients. While able to make frozen desserts like ice creams, gelatos, frozen yogurts, sorbets and the like, micro-puree style machines can also prepare non-dessert types of foods such as non-dessert purees and mousses. In addition, the devices are able to prepare either an entire batch of ingredients to be served or they can prepare a pre-desired number of servings. Known machines of this nature are commercial-grade and are exceedingly large and heavy. They require complex systems that are difficult to maintain and are typically too expensive, cumbersome and/or impractical for home use by consumers.

The present invention solves these and other problems in the prior art.

SUMMARY

An object of the present invention is to provide an improved device for the processing of food and beverage ingredients.

In one exemplary embodiment according the present disclosure, a device for processing food and beverage items is provided including a lower housing, an upper housing and a middle housing, together with an interface for user inputs and a display for providing information to the user. The device further comprises a gearbox assembly and a drive motor assembly, as well as a position motor. The position motor enables vertical movement of the gearbox assembly and drive motor assembly. The drive motor assembly provides power to a power shaft and coupling connected to a rotating blade assembly that engages with ingredients for processing.

In some embodiments, the blade assembly comprises one or more cutting blades having alternating grooves with distinct dimensions to create a cutting profile that provides for improved power management and processing efficiencies. The blade assembly in some embodiments further comprises a central hub for accommodating a power coupling, with improved engagement features for connecting the power coupling and the blade assembly.

In some embodiments, the device further includes a lifting platform and cam path tubular insert for providing vertical

2

movement of a bowl assembly and lid assembly by rotational movement of an outer bowl handle.

In some embodiments, the beaker of the bowl assembly is disposable, and can be prefilled with desired ingredients and sold as a standalone item.

BRIEF DESCRIPTION OF THE DRAWINGS

A more complete appreciation of the present disclosure and many of the attendant advantages thereof will be readily obtained as the same becomes better understood by reference to the following detailed description when considered in connection with the accompanying drawings, wherein:

FIG. 1 is an isometric view of a device according to an exemplary embodiment of the present disclosure including a bowl assembly and lid assembly;

FIG. 2 is another isometric view of the device of FIG. 1 without the bowl assembly and lid assembly;

FIG. 3A is a left side view of the device of FIG. 1 without the bowl assembly and lid assembly;

FIG. 3B is a left side view of the device of FIG. 1 with the bowl assembly and lid assembly in an up position;

FIG. 3C is a left side view of the device of FIG. 1 with the bowl assembly and lid assembly in a down position;

FIG. 4A is a right side view of the device of FIG. 1 without the bowl assembly and lid assembly;

FIG. 4B is a right side view of the device of FIG. 1 with the bowl assembly and lid assembly in an up position;

FIG. 4C is a right side view of the device of FIG. 1 with the bowl assembly and lid assembly in a down position;

FIG. 5A is a rear view of the device of FIG. 1 with the bowl assembly and lid assembly in an up position;

FIG. 5B is a right side cutaway view of the device of FIG. 5A along section A-A;

FIG. 6A is a rear view of the device of FIG. 1 with the bowl assembly and lid assembly in a down position;

FIG. 6B is a left side cutaway view of the device of FIG. 6A along section B-B;

FIG. 7 is an isometric view of internal components of the device of FIG. 1;

FIG. 8A is front view of gearbox and drive motor assemblies of the device of FIG. 1;

FIG. 8B is side cutaway view of the assemblies of FIG. 8A along section C-C;

FIG. 9 is an isometric view of the gearbox and drive motor assemblies of the device with housings removed;

FIG. 10 is an isometric view of the blade assembly of the device of FIG. 1;

FIG. 11 is a plan view of the underside of the blade assembly of FIG. 10;

FIG. 12 is a plan view of the top of the blade assembly of FIG. 10;

FIG. 13A is a section view through the center of the central support hub;

FIG. 13B is a plan view of the top of the central support hub;

FIG. 14A is an isometric view of the power coupling of the device of FIG. 1;

FIG. 14B is a plan view of the bottom of the power coupling of FIG. 14A;

FIG. 15 is a plan view of the central support hub from above;

FIG. 16A is a cutaway view of the central support hub along section A-A of FIG. 15;

FIG. 16B is a cutaway view of the central support hub along section B-B of FIG. 15;

FIG. 17 is a section view through a cutting blade of the device of FIG. 1;

FIG. 18 is a cutting profile of the blade assembly of FIG. 10;

FIG. 19 is an isometric view of a V-shaped groove on the underside of the central support hub;

FIG. 20 is an isometric view of the exterior of the beaker of the bowl assembly;

FIG. 21 is an isometric view of the outer bowl of the bowl assembly;

FIG. 22 is an isometric view of the bottom of the outer bowl;

FIG. 23 is an isometric view of the exterior of the lifting platform;

FIG. 24 is an isometric view of the interior of the lifting platform;

FIG. 25A is a plan view of the cam path tubular insert;

FIG. 25B is a sectional view of the cam path tubular insert along section A-A of FIG. 25A;

FIG. 26 is a sectional view of the cam path tubular insert inside the lifting platform;

FIG. 27 is an isometric view of the underside of the lid assembly with a blade assembly installed therein;

FIG. 28 is top view of the blade assembly and spring-biased primary sets of clips;

FIG. 29 is a side cross-sectional view of FIG. 28 along line 1-1 with additional features of the lid assembly shown;

FIG. 30 is an enlarged view of the interaction between the primary set of clips and the blade assembly;

FIG. 31A is an overhead view of the lid assembly with the clip release lever in the home position;

FIG. 31B is an overhead view of the lid assembly with the clip release lever in approximately a mid-way rotated position;

FIG. 31C is an overhead view of the lid assembly with the clip release lever in the fully-rotated position;

FIG. 32 is a partial isometric view of the underside of the upper housing;

FIG. 33A is a schematic view of the interaction between the clip release lever and the clip lever contact ledge during installation when no blade is present;

FIG. 33B is a schematic view of the interaction between the clip release lever and the clip lever contact ledge during installation when a blade is properly installed;

FIG. 34A is an overhead schematic view of the initial stages of installation of the bowl assembly and the lid assembly with no blade assembly installed in the lid assembly;

FIG. 34B is an overhead schematic view part way through the installation of the bowl assembly and the lid assembly with no blade assembly installed in the lid assembly;

FIG. 34C is an overhead schematic view of the final stages of installation of the bowl assembly and the lid assembly with no blade assembly installed in the lid assembly;

FIG. 35A is an overhead schematic view of the initial stages of installation of the bowl assembly and the lid assembly with a blade assembly properly installed in the lid assembly;

FIG. 35B is an overhead schematic view part way through the installation of the bowl assembly and the lid assembly with a blade assembly properly installed in the lid assembly; and

FIG. 35C is an overhead schematic view of the final stages of installation of the bowl assembly and the lid assembly with a blade assembly properly installed in the lid assembly.

DETAILED DESCRIPTION

The present disclosure may be understood more readily by reference to the following detailed description of the disclosure taken in connection with the accompanying drawing figures, which form a part of this disclosure. It is to be understood that this disclosure is not limited to the specific devices, methods, conditions or parameters described and/or shown herein, and that the terminology used herein is for the purpose of describing particular embodiments by way of example only and is not intended to be limiting of the claimed disclosure.

Also, as used in the specification and including the appended claims, the singular forms “a,” “an,” and “the” include the plural, and reference to a particular numerical value includes at least that particular value, unless the context clearly dictates otherwise. Ranges may be expressed herein as from “about” or “approximately” one particular value and/or to “about” or “approximately” another particular value. When such a range is expressed, another embodiment includes from the one particular value and/or to the other particular value. Similarly, when values are expressed as approximations, by use of the antecedent “about,” it will be understood that the particular value forms another embodiment. It is also understood that all spatial references, such as, for example, horizontal, vertical, top, upper, lower, bottom, left and right, are for illustrative purposes only and can be varied within the scope of the disclosure.

FIG. 1 shows an isometric view of a device 10 according to an exemplary embodiment of the present disclosure. The device 10 includes a lower housing or base 100 and an upper housing 140. A middle housing 120 extends between the lower housing 100 and upper housing 140. The upper housing 140 includes an interface 142 for receiving user inputs to control the device 10 and/or display information. The device 10 includes a removable bowl assembly 350 and lid assembly 400 on the base 100. FIG. 2 shows the device 10 with the bowl assembly 350 and lid assembly 400 removed.

As further described herein, the bowl assembly 350 receives one or more ingredients for processing. The bowl assembly 350 and lid assembly 400 are placed on the lower housing 100 as show in FIG. 1. The bowl assembly 350 and lid assembly 400 are rotatable on a lifting platform 362 from a down position to an up position, and vice versa.

FIGS. 3A-3C illustrate left side views of the device 10 without a bowl assembly 350 and lid assembly 400, with the bowl assembly 350 and lid assembly 400 in an up position, and with the bowl assembly 350 and lid assembly 400 in a down position, respectively. FIGS. 4A-4C illustrate right side views of the device 10 without a bowl assembly 350 and lid assembly 400, with the bowl assembly 350 and lid assembly 400 in an up position, and with the bowl assembly 350 and lid assembly in a down position, respectively.

As will be discussed in more detail below, when the bowl assembly 350 and lid assembly 400 are raised vertically to the up position, a blade assembly 300 within the lid assembly 400 engages with a power coupling 252 at the distal end of power shaft 250 extending from the upper housing 140. A rotational force is delivered via the power coupling 252 to the blade assembly 300 to spin one or more blades as they engage with ingredients inside the bowl assembly 350.

FIG. 5A is rear view of the device 10, with the bowl assembly 350 in the up position, showing a section line A-A. FIG. 5B is right side cutaway view of the device 10 along section A-A. FIG. 6A is rear view of the device 10, with the

bowl assembly 350 in the down position, showing a section line B-B. FIG. 6B is a left side cutaway view of the device 10 along section B-B.

The upper housing 140 includes gearbox assembly 220 and a drive motor assembly 240 connected to the gearbox assembly 220. The drive motor assembly 240 includes a drive motor housing 242 and a drive motor 244. The gearbox assembly 220 includes a gearbox housing 222 containing a plurality of gears for delivering power from the drive motor 244 to a power shaft 250. The power coupling 252 is positioned on a distal end of the power shaft 250.

FIG. 7 is an isometric view of the gearbox assembly 220 and drive motor assembly 240 of the device 10 with surrounding structure. The device 10 includes an upper support 280 and a lower support 282 positioned in the upper housing 140. The gearbox assembly 220 and drive motor assembly 240 are slidable up and down with respect to the upper and lower supports 280, 282 along a plurality of pillars 270, 272, 274, 276. The pillars and supports provide rigidity and concentric alignment. In the exemplary embodiment, the gearbox assembly 220 and drive motor assembly 240 are supported on the pillars via apertures 223, 225 in the gearbox housing 222. In other embodiments, there may be apertures on the drive motor housing 242 in addition to or instead of on the gearbox housing 222.

The device 10 includes a position motor 260 (e.g., DC motor) which drives a gearbox 262. The gearbox 262 is engaged with a vertical threaded rod or worm gear 264 extending between the upper and lower supports 280, 282. Actuation of the position motor 260, either manually via the interface 142 or automatically, moves the gearbox assembly 220 and drive motor assembly 240 up and down. The rod pitch of the worm gear 264 relate to a vertical decent rate of the device 10. The drive motor assembly 240 moves down into a cavity 122 in the middle housing 120 (see FIGS. 5B and 6B).

The power shaft 250 and power coupling 252 move together with the gearbox assembly 220 and drive motor assembly 240. Thus, actuation of the position motor 260 in turn allows for vertical movement and positioning of a blade assembly 300 removably attached to the power coupling 252. In the exemplary embodiment, the up and down travel distance is between 70 and 120 mm, or between 90 and 100 mm, such as about 94 mm.

The power coupling 252, and therefore the blade assembly 300, may be controlled at different rotational speeds (e.g., via the drive motor 244) and moved up and down (e.g., via the position motor 260) in different patterns and speeds to make different food items such as frozen purees and desserts. Exemplary programs are illustrated below in Table 1.

TABLE 1

Program	Decent		Retraction		Decent RPM/mm	Retract RPM/mm	Total Program RPM/mm
	Blade Speed (rpm)	Decent Time (s)	Blade Speed (rpm)	Retraction Time (s)			
Ice Cream	1200	60	450	30	13	2	15
Sorbet	1600	120	450	30	34	2	36
Gelato	1200	60	450	30	13	2	15
Milkshake	1600	60	450	30	17	2	19
Smoothie Bowl	1600	120	1600	30	34	9	43
Frozen Drink	1600	120	450	30	34	2	36
Slush	1600	120	1600	30	34	9	43
Whip/Re-Spin	1000	30	1000	30	5	5	11
Mix-In	450	30	450	30	2	2	5

FIG. 8A is front view of the gearbox assembly 220 and drive motor assembly 240 of the device 10 of FIG. 1. FIG. 8B is side cutaway view of the assemblies of FIG. 8A along a section C-C. As discussed above, the gear assembly 220 includes a housing 222. In the exemplary embodiment, the housing 222 includes upper and lower portions removably attached together. A housing 242 of the drive motor assembly 240 is removably attached to the lower portion of the housing 222. In other embodiments, the housing 242 is formed together with the housing 222 or at least together with the lower portion of the housing 222. In the exemplary embodiment, the housing 242 includes a plurality of openings 243 for ventilation and cooling of the drive motor 244. The device 10 may further include a fan 245 on the motor 244.

FIG. 9 is an isometric view of the gearbox assembly 220 and drive motor assembly 240 with the housings 222, 242 removed. In the exemplary embodiment, the drive motor 244 is rotatably connected to a transmission 230. The transmission 230 is connected to a first gear 232. The first gear 232 drives a gear 238, either directly or through one or a plurality of intermediate gears 234, 236, which then drives the power shaft 250.

The device 10 comprises a moving blade assembly 300 for processing food and beverage items. FIG. 10 is an isometric view of the moving blade assembly 300. FIG. 11 is a plan view of the underside of the moving blade assembly 300. FIG. 12 is a plan view of the top of the moving blade assembly 300. The moving blade assembly 300 comprises one or more cutting blades 301, 302 and one or more mixing blades 303, 304. The moving blade assembly 300 further comprises a central support hub 305. The cutting blades 301, 302 and the mixing blades 303, 304 extend outward from central support hub 305. The central support hub 305 provides a central opening 306 for accepting the power coupling 252.

With reference to FIG. 10, FIG. 11 and FIG. 12, cutting blades 301 and 302 of said moving blade assembly 300 comprise a horizontally extending length having a proximal end 312 and a distal end 313. The proximal end 312 meets the central support hub 305. The cutting blades 301, 302 comprise a leading edge 314 and a follower edge 315. Likewise, mixing blades 303, 304 extend from the central support hub 305 and are generally positioned in an opposing orientation.

FIG. 13A and FIG. 13B show the engagement features of the central support hub 305. The central support hub 305 comprises a plurality of male helical couplings 307 positioned along the interior sides of the central opening 306 and extending into the central opening 306. Between said male helical couplings 307 are vacancies 308. In an exemplary embodiment, the male helical couplings 307 comprise an

angled lead in 309. FIGS. 14A and 14B show the corresponding engagement features of the power coupling 252. The power coupling 252 has a plurality of external male helical coupling components 254 with an angled lead-in 256. Said male helical coupling components 254 engage with corresponding vacancies 308 within the central support hub 305. In some embodiments, the power coupling 252 includes a magnet 258 at a distal end to aid in positioning and removably securing the blade assembly 300 and the power coupling 252.

FIGS. 13A, and 28-30 show engagement features of the blade assembly 300 for engagement with the lid assembly 400. The central support hub 305 comprises an angled external ledge 310 and undercut 311. As will be discussed more fully below, the lid assembly 400 comprises a primary sets of clips 408 that are spring-biased toward the center of the lid assembly 400. As the central support hub 305 travels upward into the lid assembly 400, the clips engage the undercut 311. The lid assembly 400 and the blade assembly 300 are held together prior to the blade assembly 300 engaging the power coupling 252.

It will be appreciated that the moving blade assembly 300 can be a unitary structure or can comprise distinct structures joined together either directly or indirectly. The moving blade assembly 300 in one embodiment is cast stainless steel with a PVD titanium coating.

In an exemplary embodiment as shown in FIGS. 15, 16A and 16B, cutting blades 301, 302 and mixing blades 303, 304 are curved, with said curvature extending along all or at least a portion of the length of the blades in a concave configuration in relation to the direction of blade rotation during use.

As shown in FIG. 17, the said cutting blades 301, 302 further comprise a rake angle labeled "A" and a clearance angle labeled "B". The plane of rotation defines a horizontal reference plane and the axis of rotation is orthogonal to said plane of rotation. Said rake angle A is that angle extending between the rake surface 316 and the vertical axis of rotation. The clearance angle B is the angle extending between the reference plane and the underside 317 of the blade.

Referring again to FIG. 11, the first cutting blade 301 further comprises one or more grooves 320, 321, 322 to aid in cutting efficiency and power management. The grooves 320, 321, 322 are positioned along the leading edge 314 and extend into the body of the cutting blade 301. The second cutting blade 302 also comprises one or more grooves 323, 324, again to aid in cutting efficiency and power management. The grooves 323, 324 are positioned along the leading edge 314 and extend into the body of the blade 302.

In an exemplary embodiment, with respect to the first cutting blade 301, the dimension D1 of a first groove 320 is greater than the dimension D2 of a second groove 321. Likewise, the dimension D2 of the second groove 321 is greater than the dimension D3 of the third groove 322. Similarly, with respect to the second cutting blade 302, the dimension D4 of the fourth groove 323 is greater than the dimension D5 of the fifth groove 324. Referring to FIG. 18, the said grooves 320, 321, 322, 323, 324 are positioned along the leading edges 314 of the cutting blades 301, 302 so as to create alternate cutting profile rings. The largest groove on the first cutting blade 301, the first groove 320, is positioned closest to the proximal end 312 while the smallest groove on the first cutting blade 301, the third groove 322, is positioned closest to the opposing end of the first cutting blade 301. Similarly, the largest groove on the second cutting blade 302, the fourth groove 323, is positioned closer

to the proximal end 312 while the smallest groove on the second cutting blade 302, the fifth groove 324, is positioned closer to the opposing end of the second cutting blade 302. This arrangement of alternating grooves on opposing cutting blades 301, 302 creates a favorable cutting profile.

In a further aspect of the blade assembly 300, the central support hub 305 comprises at least one V-shaped groove 325 on the underside of the central support hub 305 as can be seen in FIG. 19. One edge of the V-shaped groove 325 extends along a portion of the side of the first cutting blade 301. In an alternate embodiment (not shown), a second V-shaped groove 325 could be provided along a portion of the side of the second cutting blade 302. The V-shaped groove 325 aids in directing the material to be processed away from the central support hub 305 and into the path of the cutting blades 301, 302 and the mixing blades 303, 304.

The device 10 further includes a bowl assembly 350 that joins with a lid assembly 400. The bowl assembly 350 comprises a beaker 351 and an outer bowl 352. The beaker 351 fits inside the outer bowl 352. The beaker 351 holds the food materials to be processed by the device 10 during use.

FIG. 20 is an isometric view of the exterior of the beaker 351 and one or more alternating beaker alignment features 353, 354 on the bottom of the beaker 351. In an exemplary embodiment, a first type of beaker alignment features 353 have a peripheral wall 355 that meets the bottom surface of the beaker 351 at an angle. A second type of alignment features 354 have a peripheral wall 356 that creates a vertical face 357. Once the beaker 351 is joined with the outer bowl 352, the vertical face 357 prevents rotation of the beaker 351 inside the outer bowl 352 when the moving blade assembly 300 is operating during use of the device.

The beaker alignment features 353, 354 also aid in the fixing of frozen ingredients within said beaker 351. The beaker alignment features 353, 354 prevent such ingredients from rotational movement within the beaker 351 in the direction of the moving blade assembly 300 during use. It will be appreciated that in one embodiment, the beaker 351 can be manufactured from a disposable material to enhance the convenience of using the device 10. Further, the beaker 351 can be sold as a stand alone item, and further can be prefilled with ingredients to be processed during use of the device 10.

FIG. 21 is an isometric view of the outer bowl 352 comprising a handle 358. As noted above, the beaker 351 fits within the outer bowl 352. As can be seen in FIG. 22, the bottom of outer bowl 352 comprises one or more alignment features 361 that engage with the alignment features 353, 354 on the bottom of beaker 351. The vertical faces 357 of the beaker alignment features abut the outer bowl alignment features 361 to prevent the relative rotational movement of the beaker 351 within the outer bowl 352 during use of the device 10.

The outer bowl 352 further comprises lid locking features to attach the lid assembly 400 to the outer bowl by rotation. FIG. 21 shows an outwardly projecting lip 359 along a portion of the circumference of the outer bowl 352. The lip 359 is interrupted along the circumference of the outer bowl 352. One or more protrusions 360 extend in a downward biased position from the lip 359 at the point where the lip is interrupted. Lid assembly connectors 373 travel along the lip 359 during rotation of the lid assembly 400 onto the outer bowl 352. The protrusion 360 acts as a ramp for said connectors 373. When the end of the protrusion 360 is reached, the lid assembly connectors 373 occupy the aforementioned spaces existing along the lip 359.

FIG. 23 is an isometric view of the top of the lifting platform 362. FIG. 24 is an isometric view of the interior of the lifting platform 362. The outer bowl 352 comprises locating and locking elements for positioning and connecting the outer bowl 352 to the top of the lifting platform 362. As can be seen in FIG. 22 and FIG. 23, the underside of the outer bowl 352 comprises one or more indentations 363 sized to receive corresponding projections 364 on the top of said lifting platform 362. At least one such projection on the top of said lifting platform 362 comprises a cutaway 365 (FIG. 23) to receive a corresponding ledge 366 (FIG. 22) on the outer bowl 352 when the outer bowl 352 is rotated on the lifting platform 362, locking the outer bowl 352 and the lifting platform 362 together.

Referring to FIG. 24 and FIG. 25, the interior of lifting platform 362 further comprises one or more pins 367. The pins 367 follow a cam path 368 located on the interior wall of a cam path tubular insert 369 positioned inside the lifting platform 362. FIG. 26 is a cutaway view showing the cam path tubular insert 369 positioned within the lifting platform 362 with the bowl assembly 350 in the down position. When the bowl assembly 350 is locked to the lifting platform 362 and rotated via the handle 358, the pins 367 travel along the cam path 368, vertically raising the bowl assembly 350, lid assembly 400, and lifting platform 362, enabling the blade assembly 300 to engage with the power coupling 252.

Referring to FIG. 27, a view of the underside of the lid assembly 400 with a blade assembly 300 releasably retained therein is shown. The lid assembly 400 includes a lid 404, a clip release lever 406, and a primary set of clips 408. The central support hub 305 of the blade assembly 300 is inserted into a central aperture 412 of the lid assembly 400.

Referring now to FIG. 28, an isolated overhead view of the blade assembly 300 and the primary set of clips 408 is shown. The primary set of clips 408 are spring biased toward the central support hub 305 by at least one spring 414. The spring(s) 414 are shown unattached and in the compressed state in FIG. 28. In normal use, however, the spring(s) 414 are extended and attached to opposing primary clips 408 such that the spring(s) 414 tend to pull the opposing primary clips 408 toward each other.

Referring now to FIGS. 29 and 30, the primary set of clips 408 are shown engaged with the central support hub 305. The central support hub 305 includes an external angled ledge 310 and an external undercut 311. Each primary clip in the set 408 includes a primary engagement structure 418 that includes a primary upper retention surface 420 and a primary lower surface 422. Although two primary clips 408 are shown in the embodiment, more or fewer than two clips can be utilized.

During the connection process, when the central support hub 305 of the blade assembly 300 is positioned in lid assembly 400, the primary lower surfaces 422 engage with the external angled ledge 310 of the central support hub 305. The primary lower surfaces 422 contact the external angled ledge 310 of the central support hub 305 and, when the blade assembly is pressed into the lid assembly 400, the primary lower surfaces 422 engage the external angled ledge 310 and tend to urge the primary set of clips 408 to move outwards against the force of the spring(s) 414. The outward movement of the primary set of clips 408 allows the primary engagement structures 418 to pass by the outside of the central support hub 305. When a blade assembly 300 is not located in the lid assembly 400, the primary set of clips 408 are urged by the spring(s) 414 to a rest position that is further inward than shown in, e.g., FIG. 30.

As shown in FIGS. 29 and 30, after the primary engagement structures 418 travel past the outside of the central support hub 305, the primary engagement structures 418 then enter the external central support hub undercut 311. The spring(s) 414 urge the primary set of clips 408 toward, and remain in, an engaged position. The external central support hub undercut 311 has a generally flat surface that extends radially outward at an approximately 90-degree angle relative to the central axis of the blade assembly 300. Similarly, the primary upper retention surface 420 is preferably angled such that it engages with the external central support hub undercut 311 in a manner that retains the blade assembly 300 in the lid assembly 400 even in the event that significant disengagement forces are applied to the blade assembly 300.

Referring now to FIGS. 31A-C, the lid assembly 400 also includes a clip release lever 406. The clip release lever 406 is retained on the remainder of the lid assembly 400 in a manner such that it can move rotationally relative to the remainder of the lid assembly 404 within a pre-determined range of motion. The embodiment shown permits rotation from a home position (0-degrees of rotation) to a fully-rotated position. In the embodiment shown, the clip release lever 406 includes a lever arm 430 and primary lever engagement surfaces 432. Therefore, motion of the clip release lever 406 directly imparts motion on the primary set of the clips 408, and vice versa, as shown sequentially in FIGS. 31A, 31B and 31C.

The primary lever engagement surfaces 432 engage with the pins 436 of the primary set of clips 408 during at least some portion of the rotation of the clip release lever 406. The primary lever engagement surface 432 acts to move the primary set of clips 408 from the home position where the primary set of clips 408 are fully spring biased toward each other and are in the rest position (FIG. 31A) to a fully-rotated position where the primary set of clips 408 are retracted away from each other (FIG. 31C). As shown, the primary lever engagement surfaces 432 are located on an inner surface of opposing angled slots on the clip release lever 406 and engage with pins 436 on each of the primary clips 408 during at least a portion of the rotational travel of the clip release lever 406. In the present embodiment, the primary set of clips 408 are spring biased toward the central hub support 305 when a blade assembly 300 is positioned in lid assembly 400. In the present embodiment, the clip release lever 406 is in the mid-way position (see FIG. 31B), which is approximately half-way between the home position (FIG. 31A) and the fully-rotated position (FIG. 31C), when a blade assembly 300 is positioned in the lid assembly 400. Once the clip release lever 406 has been rotated past the position shown in FIG. 31B, the primary set of clips 408 begin to retract from the central support hub 305 until the primary set of clips 408 are fully retracted and cease retaining the blade assembly 300 in the lid assembly 400. When the clip release lever 406 is in the fully-rotated position (FIG. 31C), the primary set of clips 408 are retracted outward to a position outside of the central support hub 305, allowing the blade assembly 300 to be disengaged from the lid assembly 400, if desired. Likewise, in the position shown in FIG. 31C, the blade assembly 300 can also be installed into the lid assembly 400.

Referring now to FIGS. 32, 33A, and 33B, the upper housing 140 includes a clip lever contact ledge 440. During the installation of the bowl assembly 350 and the lid assembly 400 onto the lower housing 100, the bowl and lid assemblies 350, 400 are placed on the lifting platform 360 and rotated relative to the lower base 100. As the installation of the bowl assembly 350 and the lid assembly 400 takes

place, the lid assembly **400** rises upwards as it rotates relative to the lower base **100**. In the event that the blade assembly **300** is properly installed in the lid assembly **400**, the clip release lever **406** will rise to a height necessary to contact the clip lever contact ledge **440** during its rotation (see FIG. **33B**). Conversely, in the event the blade assembly **300** is not installed in the lid assembly **400**, the clip release lever **406** will not rise to the height necessary to contact the clip lever contact ledge **440** (FIG. **33A**) and the clip release lever will rotate past the ledge **440**. In instances where the clip release lever **406** contacts the clip lever contact ledge **440**, the rotation of the clip release lever **406** relative to the lower base **100** will halt, and the clip release lever **406** will commence rotation relative to the remainder of the lid assembly **400**. In instances where the clip release lever **406** does not contact the clip lever contact ledge **440**, the rotation of the clip release lever **406** relative to the lower base **100** will continue, and the clip release lever **406** will continue to rotate with the remainder of the lid assembly **400** relative to the lower base **100**. Therefore, the clip release lever **406** will be in a different position when the bowl assembly **350** and lid assembly **400** are fully installed depending on whether a blade assembly **300** is installed or not. In some embodiments, the final position of the clip release lever **406** when the bowl assembly **350** and lid assembly **400** are installed can be detected by the device to determine whether to operate as intended, or to indicate to the user that the blade assembly **300** is not properly installed.

In order for the power shaft **250** to properly connect to the blade assembly **300** during installation, the blade assembly **300** must be seated properly in the lid assembly **400** both prior to and immediately after completion of the connection to the power shaft **250**. In order to detect proper location of the blade assembly **300**, the device **10** can further include a blade assembly detection mechanism **450** that detects the positioning of the blade assembly **300**. For example, the system can utilize optical, mechanical and/or electrical means.

In operation, a user places ingredient(s) inside the beaker **351** and then into a freezer until the ingredients are brought to the appropriate temperature; typically, the temperature is sub-freezing. The beaker **351** holding the frozen ingredients is then placed into the outer bowl **352**. The blade assembly **300** is inserted into the lid assembly **400** such that the external central hub undercut engages the spring-biased primary sets of clips **408**. The installation of the blade assembly **300** into the lid assembly **400** causes the clip release lever to rotate from the home position (FIG. **31A**) to the mid-way rotated position (FIG. **32B**). The lid assembly **400** (with installed blade assembly **300**) is then placed onto the beaker **351** and outer bowl **352** and, together, placed onto the lifting platform **360**.

The user then rotates the bowl and the lid assemblies **350**, **400** relative to the lower base **100** such that the lifting platform **362** rises upwards, moving the blade and lid assemblies **350**, **400** toward the power shaft **250** and power shaft coupling **254** until the connection is completed. During the rotation, the clip release lever **406** rises to a height necessary to contact the clip lever contact ledge **440** (FIG. **35B**) which halts the rotation of the clip release lever **406** relative to the lower base **100** and causes rotation of the clip release lever **406** relative to the remainder of the lid assembly **400**. Preferably, the lid assembly **400** and blade assembly **300** are raised to a height necessary for the power shaft **250**/power shaft coupling **254** connection to be at least partially complete prior to the clip release lever contacting the ledge. More preferably, the power shaft **250**/power shaft

coupling **254** connection is fully complete prior to the clip release lever contacting the ledge. Once the power shaft **250**/power shaft coupling **254** connection is complete, the magnet **258** on the power shaft **250** attaches to the blade assembly **300**, retaining the blade assembly **300** in place. As the installation continues, the rotation of the clip release lever **406** relative to the remainder of the lid assembly **400** causes the primary set of clips **408** to disengage from the central support hub **305** of the blade assembly **300** while the bowl assembly **350** and remainder of the lid assembly **400** continue rotating until the installation is completed.

In instances where the blade assembly **300** is not installed in the lid assembly **400** prior to installation of the bowl assembly **350** and lid assembly **400** into the device, the clip release lever **406** will be located in the home position at the commencement of the installation process. As the bowl assembly **350** and lid assembly **400** rotate on the lifting platform **360**, the clip release arm **430** will, as shown in FIGS. **34A-C**, pass under the ledge **440** prior to rising to the height necessary to contact the ledge **440**. The clip release lever **406** will continue to rotate with the lid assembly **400** throughout installation, indicating to the device **10** and/or user that the blade assembly **300** is not installed, and the device **10** will not operate as expected.

In instances where the blade assembly **300** is properly installed in the bowl assembly **350** and lid assembly **400**, the user may optionally select to operate the device **10** using a pre-determined program to produce a desired product using the user interface. Alternatively, a manual operation, where the user dictates the speed of the rotation of the blade, the rate of descent of the blade, and/or the depth the blade enters into the ingredient(s) (among other controllable parameters), can be carried out. The drive motor operates to turn the power shaft **250** and, accordingly, the blade assembly **300**. As the blade assembly **300** turns, the cutting blades **301**, **302** and mixing blades **303**, **304** also begin to spin.

The position motor **260** operates to move drive motor assembly **240** and the blade assembly **300** upward and downward, based on the direction of operation. The now-spinning blade assembly **300** can then be plunged to a desired depth into the frozen ingredients at a desired spin rate and descent rate. As the blade assembly **300** spins in the frozen ingredients, the cutting blades **301**, **302** operate to repeatedly cut through a thin layer of the frozen ingredients and the mixing blades **303**, **304** operate to mix and smooth the loosened frozen ingredients.

After the blade assembly **300** has reached the desired lowest position in the frozen ingredients, the blade assembly **300** is then moved back upwards toward the lid assembly **400** by reversing the direction of the position motor **260**. The blade assembly **300** can, optionally, be repeatedly plunged into the frozen ingredient(s) additional times. After the final plunge into the frozen ingredients, the position motor **260** is operated until the blade assembly **300** is returned to the lid assembly **400**.

The user then rotates the bowl and lid assemblies **350**, **400** relative to the lower base **100** in the opposite direction that was utilized during installation. The rotation of the bowl and lid assemblies **350**, **400** permits rotation of the clip release lever **406** from the fully-rotated position to the midway rotated position and the primary set of clips **408** re-engage with the central support hub **305** of the blade assembly **300**. The rotation of the bowl assembly and lid assemblies **350**, **400** also causes the lifting platform **360** to move downwards toward the lower base **100**. As the bowl and lid assemblies **350**, **400** move downwards, the blade assembly **300** separates from the power coupling **252**. The bowl and lid

13

assemblies 350, 400 are then removed from the remainder of the device 10, and the lid assembly 400 (with the blade assembly 300 still installed therein) is removed from the bowl assembly 350. The now-processed ingredients can now be enjoyed.

The user can optionally rotate the clip release lever 406 to the fully rotated position, releasing the primary set of clips 408 from engagement with the central support hub 305. With both the primary sets of clips 408 released, the user can easily remove the blade assembly 300 from the lid assembly 400 for cleaning and/or storage.

As shown throughout the drawings, like reference numerals designate like or corresponding parts. While illustrative embodiments of the present disclosure have been described and illustrated above, it should be understood that these are exemplary of the disclosure and are not to be considered as limiting. Additions, deletions, substitutions, and other modifications can be made without departing from the spirit or scope of the present disclosure. Accordingly, the present disclosure is not to be considered as limited by the foregoing description.

What is claimed is:

1. A blade assembly, comprising:
 - a central support hub having an upper end and a lower end positioned below the upper end, the central support hub defining a central axis;
 - at least one cutting blade extending outward from a circumferential surface of the central support hub and defining a curved leading edge;
 - at least one mixing blade;
 - a central opening located at the upper end of the central support hub and coaxial with the central axis, the central opening being configured to receive a power shaft therein;
 - an angled ledge located at the upper end of the central support hub, the angled ledge extending about at least a portion of an outer perimeter of the central support hub; and
 - an undercut defined by a lower surface of the angled ledge of the central support hub;
 - wherein the undercut defines an engagement surface that extends outwards from the central axis of the central support hub; and
 - wherein the undercut is configured to receive and retain a clip mechanism.
2. The blade assembly of claim 1, wherein the at least one mixing blade is two mixing blades.

14

3. The blade assembly of claim 1, wherein the at least one cutting blade is two cutting blades.

4. The blade assembly of claim 1, wherein the at least one mixing blade is two mixing blades and the at least one cutting blade is two cutting blades, the two mixing blades extending outwards from the circumferential surface of the central support hub in opposite directions from each other and the two mixing blades extending outwards from the circumferential surface of the central support hub in opposite directions from each other.

5. The blade assembly of claim 4, wherein the two mixing blades are positioned at approximately a right angle relative to the two cutting blades.

6. The blade assembly of claim 1, wherein the central hub is generally cylindrical.

7. The blade assembly of claim 1, wherein the at least one cutting blade includes a first cutting blade and a second cutting blade, the first cutting blade including a first groove located at a first distance from the central axis, the first groove defining a first length.

8. The blade assembly of claim 7, wherein the second cutting blade includes a second groove located at a second distance from the central axis, the second groove defining a second length.

9. The blade assembly of claim 8, wherein the first length of the first groove is greater than the second length of the second groove.

10. The blade assembly of claim 9, wherein the first distance from the central axis is smaller than the second distance from the central axis.

11. The blade assembly of claim 10, wherein the first cutting blade includes a third groove located at a third distance from the central axis, the third groove defining a third length.

12. The blade assembly of claim 1, wherein the lower end of the central support hub includes an underside surface, the underside surface including a V-shaped groove that extends across a portion of a side of the at least one cutting blade.

13. The blade assembly of claim 1, wherein the at least one cutting blade is positioned below the upper end of the central support hub.

14. The blade assembly of claim 1, wherein the at least one mixing blade is positioned below the upper end of the central support hub.

15. The blade assembly of claim 1, wherein the angled ledge is further located above the at least one mixing blade and the at least one cutting blade.

* * * * *