

J. KOENIG.
COMPRESSOR.

APPLICATION FILED DEC. 28, 1912.

1,183,077.

Patented May 16, 1916.
2 SHEETS—SHEET 1.

Fig. 2.

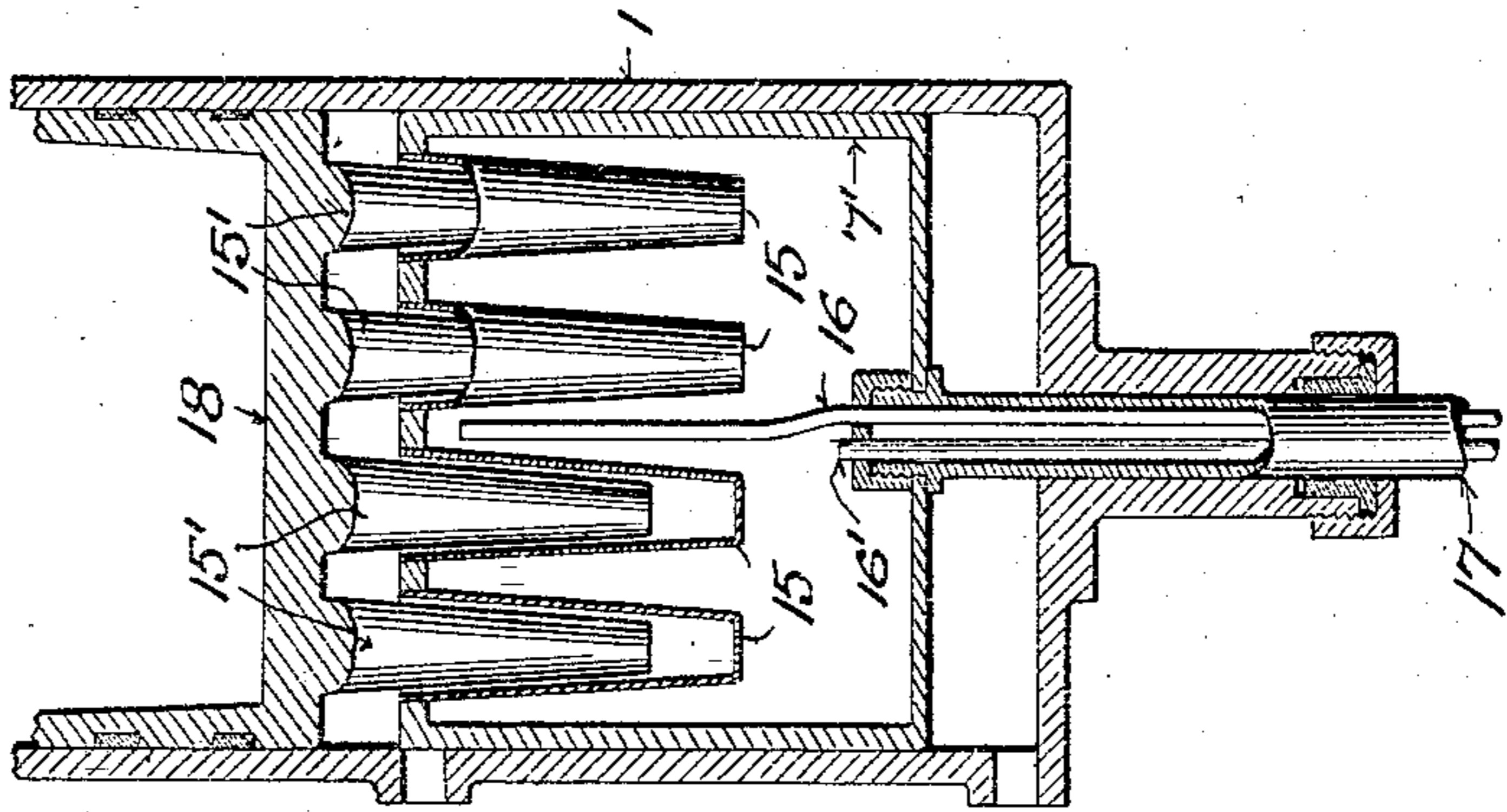
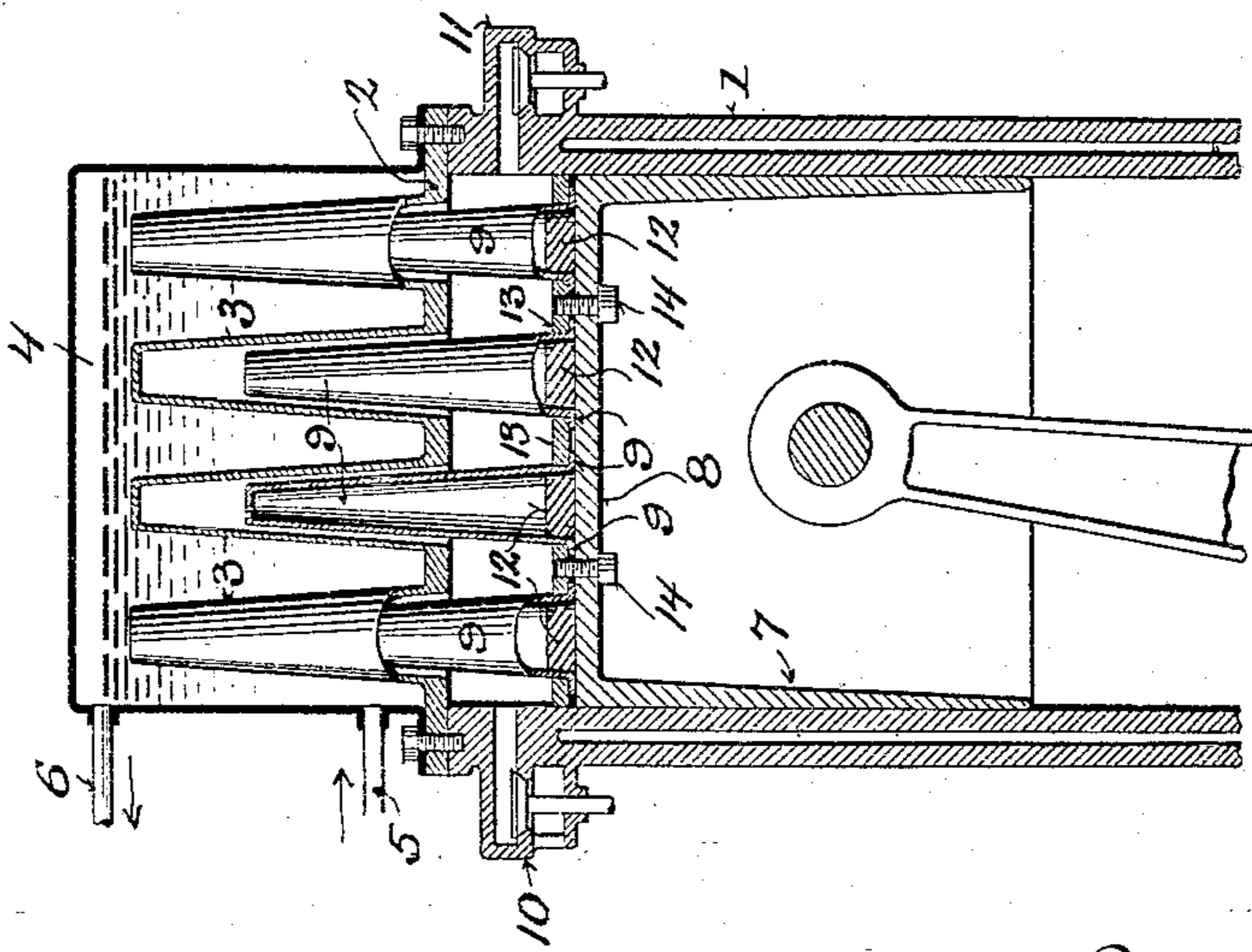

Fig. 1.



Witnesses:
Carroll Young
May Downey

Inventor:

Joseph Koenig
By *Clifton Young*
Attorneys.

J. KOENIG.
COMPRESSOR.

APPLICATION FILED DEC. 28, 1912.

1,183,077.

Patented May 16, 1916.

2 SHEETS—SHEET 2.

Fig. 4.

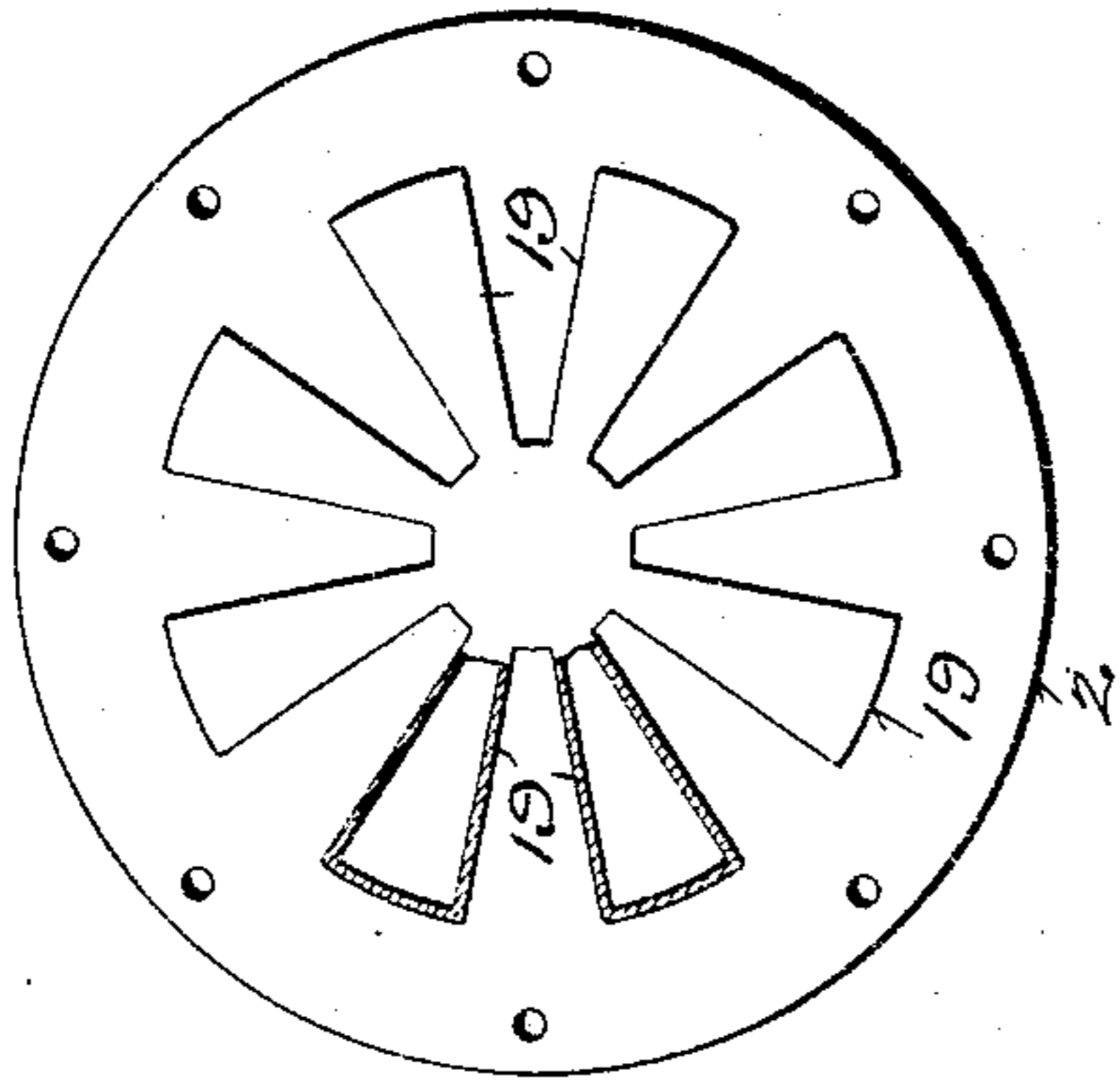

Fig. 5.

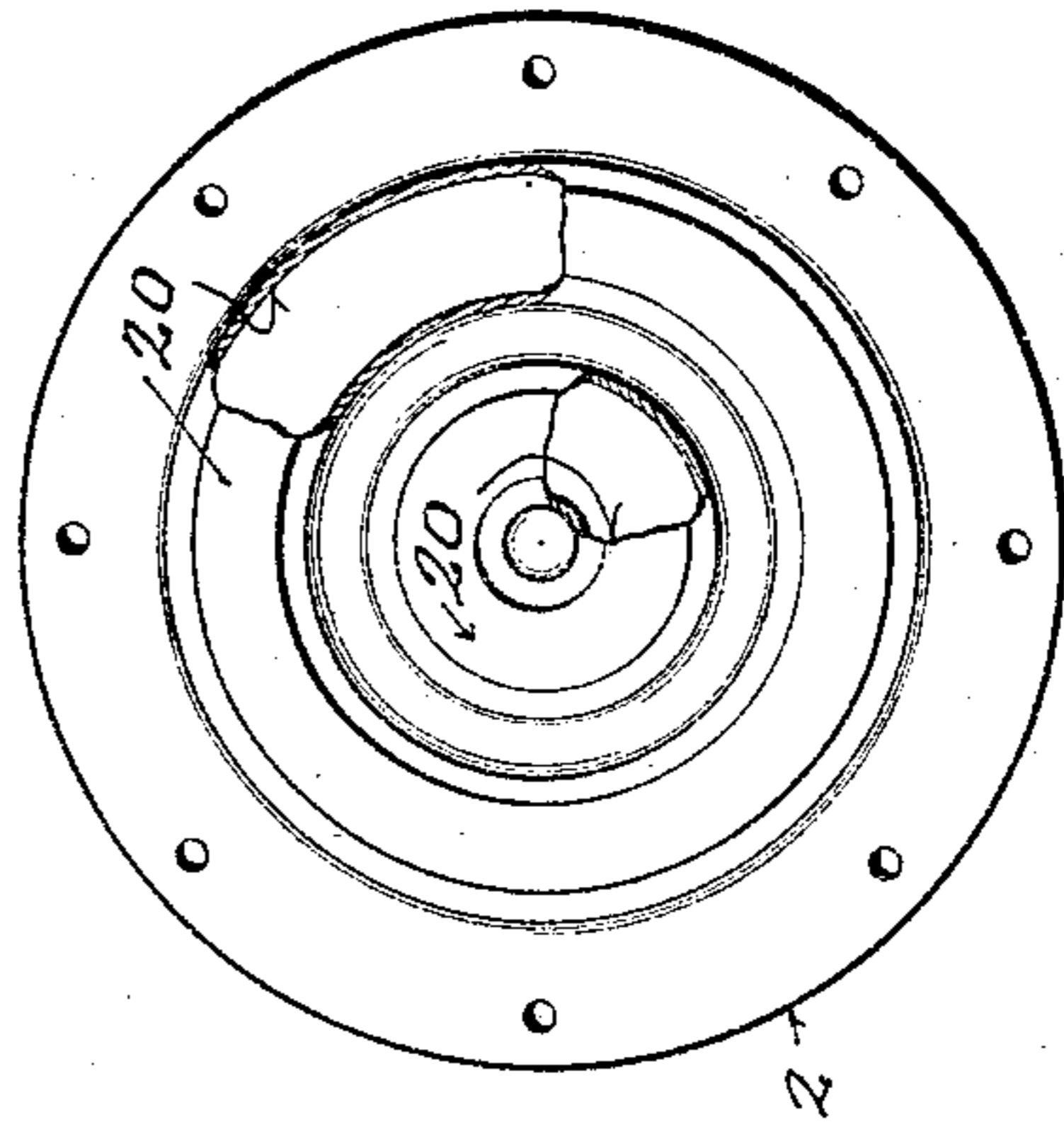
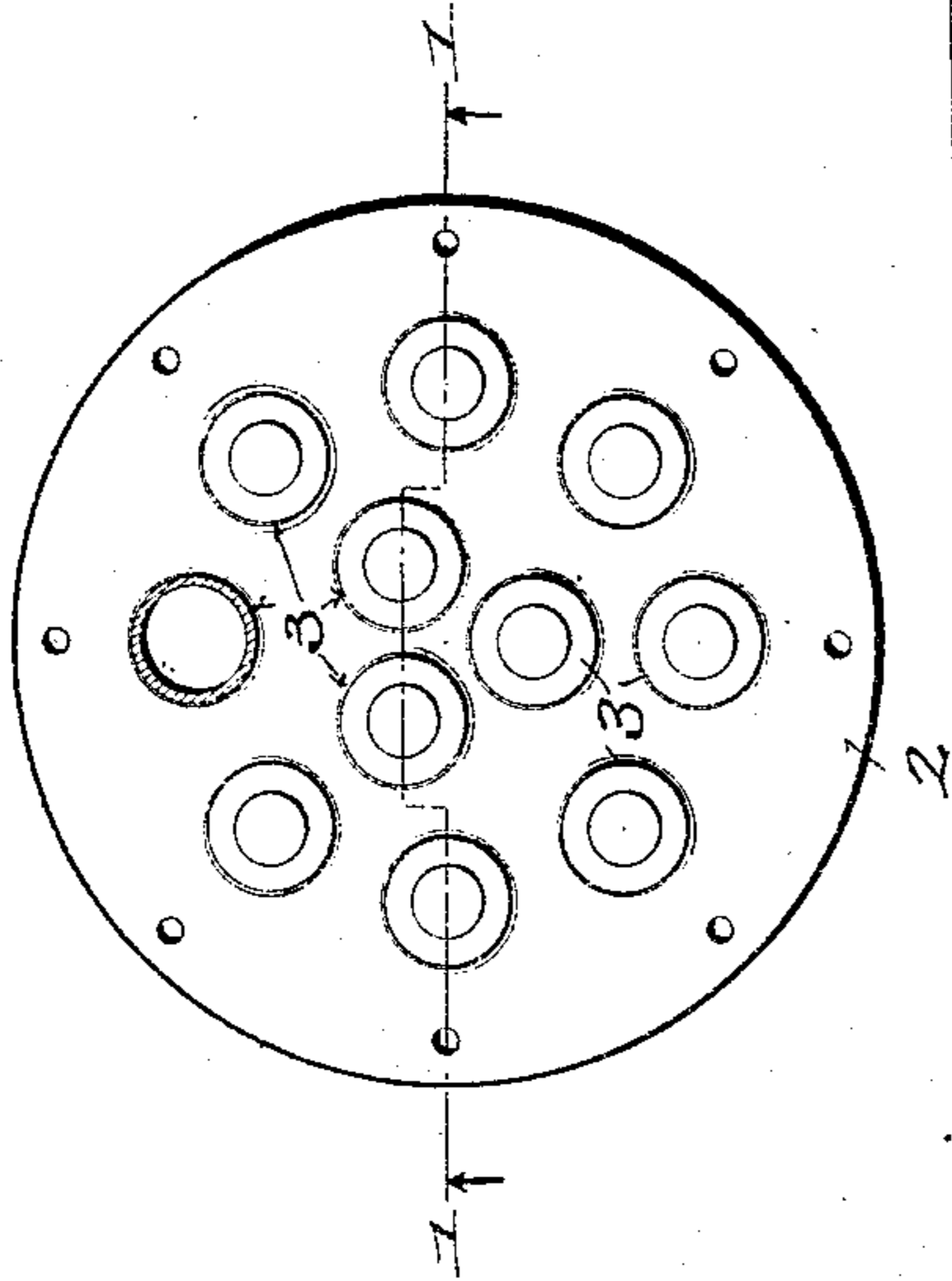

Fig. 6.



*Witnessed:
Charles Young
May Downey*

*Inventor:
Joseph Koenig
By *Charles Young*
Attorneys.*

UNITED STATES PATENT OFFICE.

JOSEPH KOENIG, OF TWO RIVERS, WISCONSIN.

COMPRESSOR.

1,183,077.

Specification of Letters Patent. Patented May 16, 1916.

Application filed December 28, 1912. Serial No. 738,977.

To all whom it may concern:

Be it known that I, JOSEPH KOENIG, a citizen of the United States, and resident of Two Rivers, in the county of Manitowoc and State of Wisconsin, have invented certain new and useful Improvements in Compressors; and I do hereby declare that the following is a full, clear, and exact description thereof.

10 The primary object of my invention is to provide a simple, economical and effective means for lowering the temperature of compressed fluids coincident to their compression, whereby economy in expenditure of the applied power is effected, which economy is due to the fact that the expansive force generated by the fluids through heat, is, to a large extent, eliminated as an opposing factor to said applied power.

20 This application comprises matter disclosed in an application for patent filed by me March 7, 1911, Serial Number 612878. My invention in the present instance is particularly applicable to fluid compressors in general, internal combustion engines and hot-air engines, the same being effectually utilized in internal combustion engines such as disclosed in the above referred to application for patent wherein gaseous fluid is compressed and thereafter shifted through a thermal chamber, where it is heated preparatory to being exploded.

35 The specific object of my invention is to provide the opposite end walls of compressor members with nested male and female sets of fins, one or both of which sets may be artificially cooled, the male members being adapted to fit within the female members, whereby complete displacement of the fluid therebetween is effected. By this construction of cooling fins it is apparent that a large cooling surface area is obtained in proportion to the size of the compression chamber or members.

45 With the above objects in view the invention consists in certain peculiarities of construction and combination of parts as set forth hereinafter with reference to the accompanying drawings and subsequently claimed.

55 In the drawings Figure 1 represents a sectional elevation of a pair of compression members embodying the features of my invention, the members comprising a cylinder, the head of which is provided

with a series of female fins, and a piston having in connection with its head a series of male fins; Fig. 2 illustrates a sectional view showing another form of my invention wherein the piston is provided with means for admitting a cooling fluid; Fig. 3, a detailed plan view of the fins as shown in Fig. 1, the same being in the form of conical tubes; Fig. 4, a plan view of another form of fin construction, wherein said fins extend radially from a common center, and Fig. 5, still another form of my invention, wherein the fins are formed in a series of concentric rings, it being understood that in each form the male members correspond to the female members shown and are adapted to nest therein.

75 Referring by characters to the drawings, 1 represents a portion of a cylinder, provided with a head 2, which head has a series of tubular fins 3 projecting outwardly therefrom, the mouths of the tubes being open while their upper ends are closed. Surrounding the fins is a closed jacket 4, which jacket serves as a container for water or other cooling medium that may be supplied from a suitable source by receiving and discharge pipes 5, 6 respectively. It is apparent, however, that the water jacket may, if desired, be provided with an open mouth for the reception of its supply of cooling fluid in place of the pipe connections shown.

90 Mounted in the cylinder is a piston 7, the head-wall 8 of which has fitted thereto a series of hollow tubular fins 9, which fins constitute the male members and are adapted to nest within the female members 3 when the piston is moved to an approximate abutting position with the head end of the cylinder, whereby fluid drawn into the cylinder incidental to downward stroke of the piston is entirely expelled upon the compression stroke, it being understood that the cylinder is provided with the usual valve-controlled inlet and outlet conductors 10, 11, respectively. The hollow male fins are closed at their upper ends, their mouths being provided with flanged extensions 9' which are seated against the face of the piston head 8, the mouths being closed by suitable plugs 12 to thus render the said fins air tight. The female fins are secured in place upon the piston-head 8 by means of a perforated ring 13, which per-

forations are provided for the reception of the fin members, the ring being dropped thereover and secured by suitable retaining bolts 14 which clamp said ring and piston head together, thus firmly binding the male fin members in position.

From the foregoing description it is apparent that the cooling medium surrounding the female fin members will have the effect of keeping the large radiating surfaces about said members at a low temperature, which, to a great extent, will counteract the effect of heat due to compression of a fluid between the cylinder head and piston head, and hence it is apparent, owing to the fact that the fluid is being cooled during compression, that the force of the compression power applied will not be opposed by the expansive influence of a compressed fluid of higher temperature and that a proportionate economy in the method of compression will result.

In the foregoing arrangement I have illustrated a fixed movable member of a compressor provided with fins made in accordance with my invention. Referring to Fig. 2, however, I have shown another form of my invention, wherein the movable member or piston 7' containing female fins may be subjected to a cooling fluid by circulating pipes 16, 16', the said pipes passing through a hollow piston-rod 17 as shown. The male members 15' in this instance are shown solid and extending from a head-wall 18, which head-wall may be movable as illustrated, or the same may constitute a fixed cylinder head.

Fig. 3 illustrates a plan view of the female tubular fins, and Fig. 4 a form of radially disposed female fins 19 which may be cast with a cylinder head or attached thereto

in any suitable manner. Fig. 5 illustrates a series of female fins made in the form of hollow rings 20.

It is understood that while I have shown the conical tubular fin members 9 as being cast in one piece with a cylinder head 2 that the same may be made in separate units and spun into apertures within said head or otherwise secured thereto without departing from the spirit of my invention.

I claim:

1. In a compressor device, a pair of compressor members one at least of which is reciprocative, a series of tapered tubes extending from one of said members and closed at their outer ends, a fluid cooling jacket surrounding said tubes, a series of tapered plungers carried by the other member and adapted to engage in the tubes and said members being associated with a compression cylinder having valve openings in its sides between the members.

2. In a compressor device, a compressor member, a plurality of tapered hollow plungers, lateral flanges at the base of the plungers, a securing plate provided with openings receiving the plungers, means for securing said plate to the compressor member and plugs disposed in the bases of said tapered plungers and bearing against the compressor member by clamping action of the said plate whereby the interiors of the plungers are seated.

In testimony that I claim the foregoing I have hereunto set my hand at Two Rivers in the county of Manitowoc and State of Wisconsin in the presence of two witnesses.

JOSEPH KOENIG.

Witnesses:

MARCELLA J. GAFFNEY,
AUGUST H. GLOE, Jr.

Copies of this patent may be obtained for five cents each, by addressing the "Commissioner of Patents, Washington, D. C."