



US011789239B2

(12) **United States Patent**
Baik et al.

(10) **Patent No.:** **US 11,789,239 B2**
(45) **Date of Patent:** **Oct. 17, 2023**

(54) **OPTICAL IMAGING SYSTEM**

USPC 359/708
See application file for complete search history.

(71) Applicant: **Samsung Electro-Mechanics Co., Ltd.**,
Suwon-si (KR)

(56) **References Cited**

(72) Inventors: **Jae Hyun Baik**, Suwon-si (KR); **Min Hyuk Im**, Suwon-si (KR); **Yong Joo Jo**, Suwon-si (KR); **Ga Young An**, Suwon-si (KR)

U.S. PATENT DOCUMENTS

8,599,495 B1 12/2013 Tsai et al.
9,423,595 B2 8/2016 Shinohara et al.
2013/0050846 A1 2/2013 Huang
2014/0043694 A1 2/2014 Tsai et al.
2014/0285906 A1 9/2014 Huang

(Continued)

(73) Assignee: **Samsung Electro-Mechanics Co., Ltd.**,
Suwon-si (KR)

(*) Notice: Subject to any disclaimer, the term of this patent is extended or adjusted under 35 U.S.C. 154(b) by 300 days.

FOREIGN PATENT DOCUMENTS

CN 202886720 U 4/2013
CN 204359999 U 5/2015

(Continued)

(21) Appl. No.: **17/088,675**

(22) Filed: **Nov. 4, 2020**

OTHER PUBLICATIONS

(65) **Prior Publication Data**

US 2021/0048648 A1 Feb. 18, 2021

United States Office Action dated Mar. 3, 2021 in related U.S. Appl. No. 16/424,774 (8 pages in English).

(Continued)

Related U.S. Application Data

(63) Continuation of application No. 16/424,774, filed on May 29, 2019, now Pat. No. 11,353,686.

Primary Examiner — Collin X Beatty

(74) *Attorney, Agent, or Firm* — NSIP Law

(30) **Foreign Application Priority Data**

May 29, 2018 (KR) 10-2018-0061393
Sep. 5, 2018 (KR) 10-2018-0106185

(57) **ABSTRACT**

An optical imaging system includes a first lens, a second lens, a third lens, a fourth lens, a fifth lens, a sixth lens, and a seventh lens sequentially disposed in numerical order along an optical axis of the optical imaging system from an object side of the optical imaging system toward an imaging plane of the optical imaging system, wherein the optical imaging system satisfies $1 < |f_{134567} - f|/f$, where f_{134567} is a composite focal length of the first to seventh lenses calculated with an index of refraction of the second lens set to 1.0, f is an overall focal length of the optical imaging system, and f_{134567} and f are expressed in a same unit of measurement.

(51) **Int. Cl.**

G02B 13/00 (2006.01)
G02B 9/64 (2006.01)

(52) **U.S. Cl.**

CPC **G02B 13/0045** (2013.01); **G02B 9/64** (2013.01)

(58) **Field of Classification Search**

CPC G02B 13/0045; G02B 9/64

18 Claims, 59 Drawing Sheets

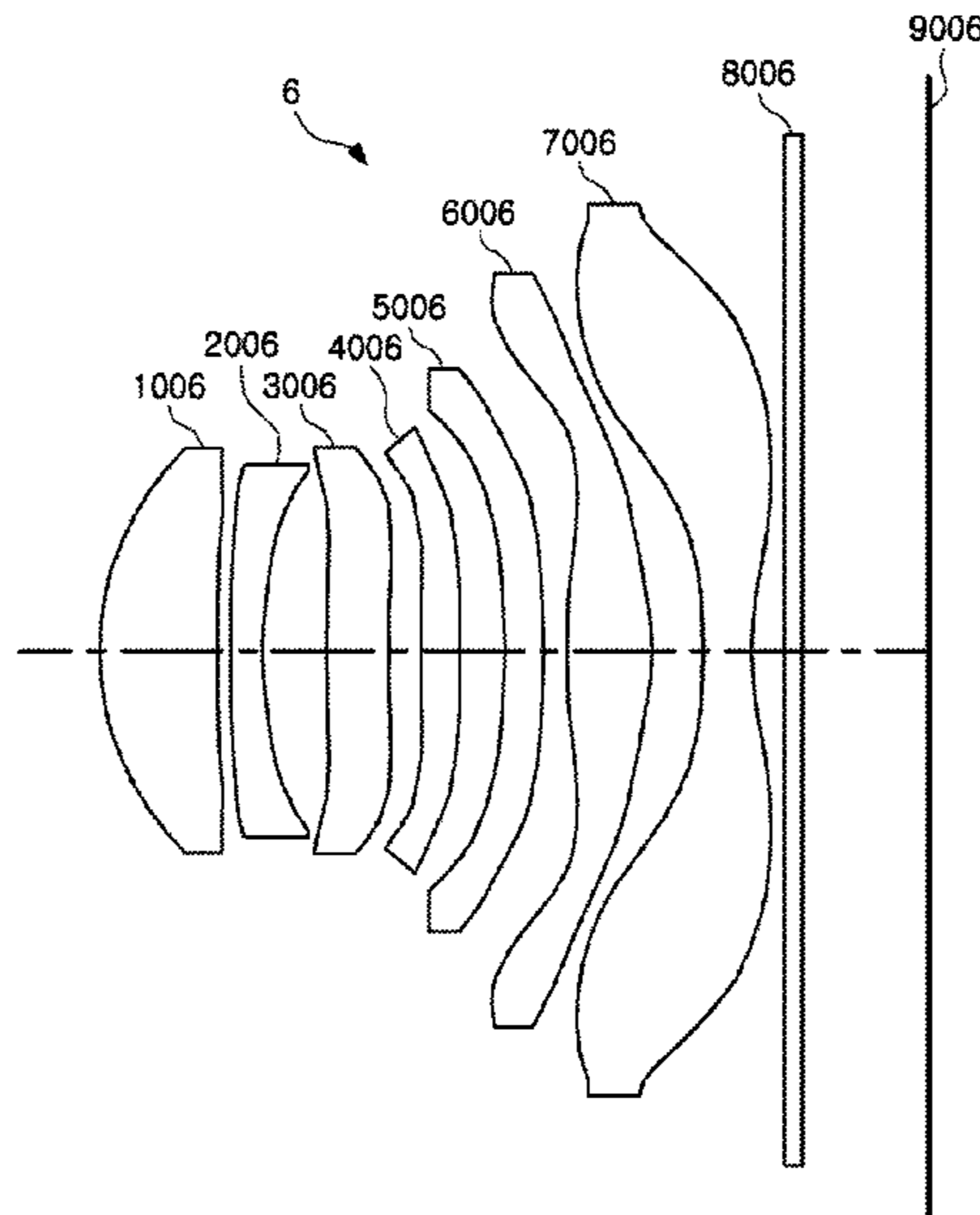

(56)

References Cited

U.S. PATENT DOCUMENTS

2015/0212298 A1 7/2015 Shinohara et al.
2016/0025953 A1 1/2016 Jung
2017/0184819 A1 6/2017 Shi
2017/0336605 A1 11/2017 Lai et al.
2019/0049700 A1 2/2019 Kunimatsu et al.
2019/0121066 A1* 4/2019 Yan G02B 9/64
2019/0302424 A1 10/2019 Kuo et al.
2019/0369360 A1 12/2019 Jung et al.
2019/0369362 A1 12/2019 Son et al.

FOREIGN PATENT DOCUMENTS

CN 104965295 A 10/2015
CN 105278074 A 1/2016
CN 105988193 A 10/2016
CN 105988199 A 10/2016
CN 107402436 A 11/2017
CN 107450160 A 12/2017
CN 107621683 A 1/2018
CN 109073862 A 12/2018
CN 110542986 A 12/2019
CN 209911627 U 1/2020
JP 2015-72402 A 4/2015
JP 2015-72403 A 4/2015

JP 2017-116911 A 6/2017
JP WO2017/199633 A1 11/2017

OTHER PUBLICATIONS

Notice of Reason for Rejection dated Nov. 9, 2022, in counterpart Korean Patent Application No. 10-2021-0004540 (13 pages in English, 8 pages in Korean).
Korean Office Action dated Mar. 18, 2022, in counterpart Korean Patent Application No. 10-2020-0007488 (7 pages in English and 5 pages in Korean).
Korean Office Action dated Sep. 13, 2021, in counterpart Korean Patent Application No. 10-2020-0007488 (9 pages in English and 6 pages in Korean).
Chinese Office Action dated Apr. 18, 2022, in counterpart Chinese Patent Application No. 202011032493.9 (8 pages in English and 8 pages in Chinese).
Chinese Office Action dated Mar. 3, 2021 in counterpart Chinese Patent Application No. 201910441856.5 (9 pages in English and 11 pages in Chinese).
Chinese Office Action dated Oct. 26, 2021, in counterpart Chinese Patent Application No. 201910441856.5 (11 pages in English and 11 pages in Chinese).
Chinese Office Action dated Apr. 28, 2023, in Counterpart Chinese Patent Application No. 202011032493.9 (4 Pages in English, 7 Pages in Chinese).

* cited by examiner

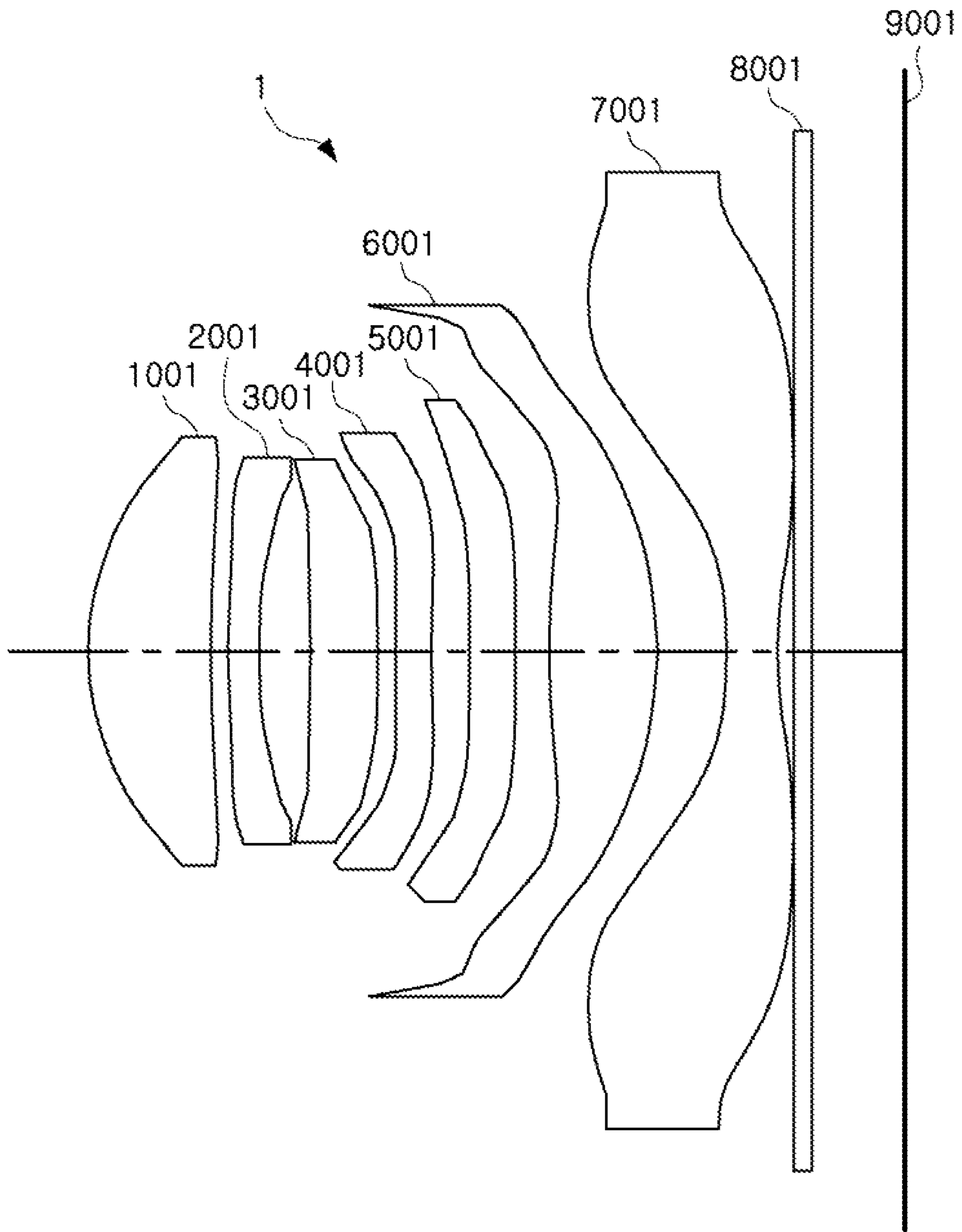

FIG. 1

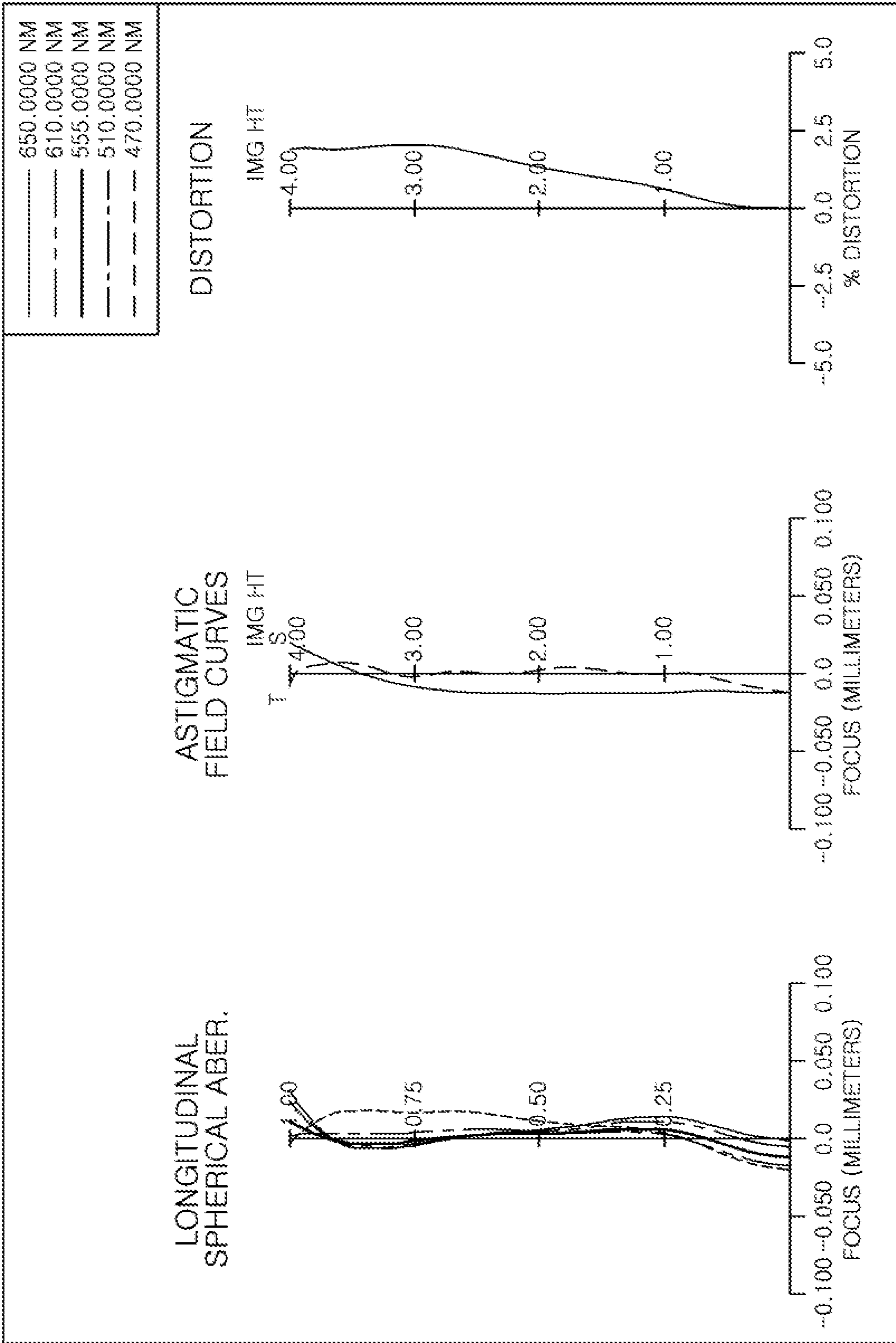

FIG. 2

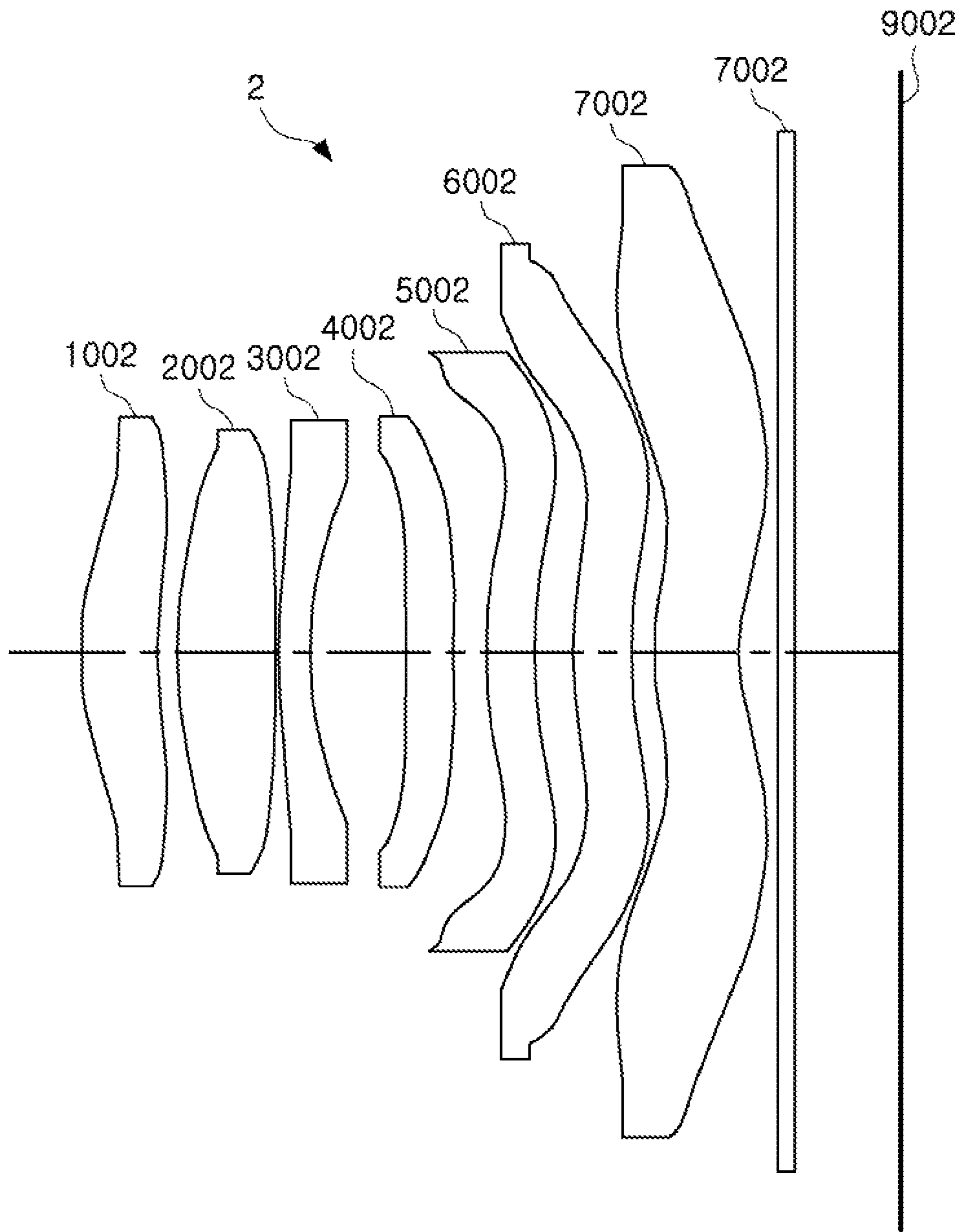

FIG. 3

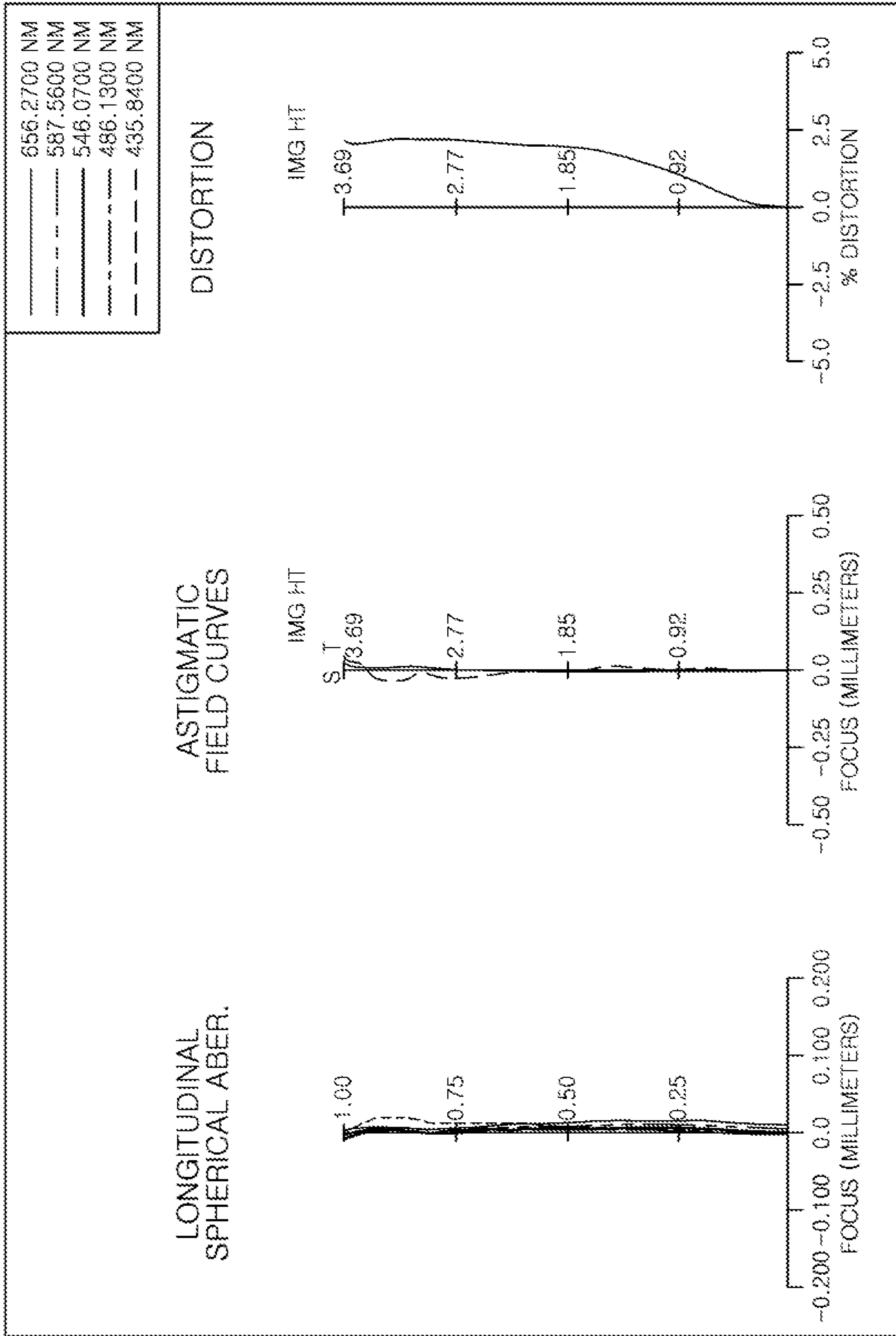

FIG. 4

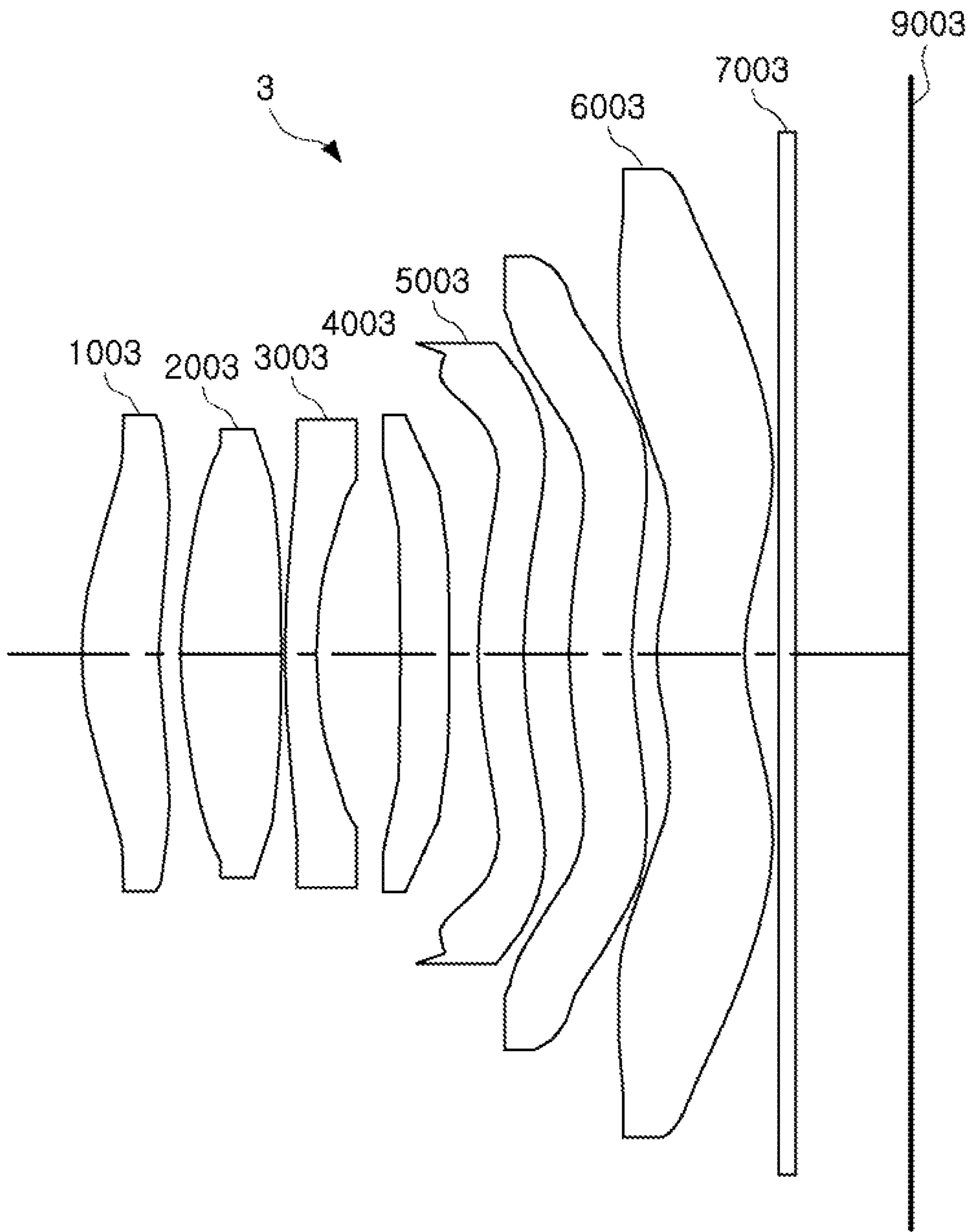

FIG. 5

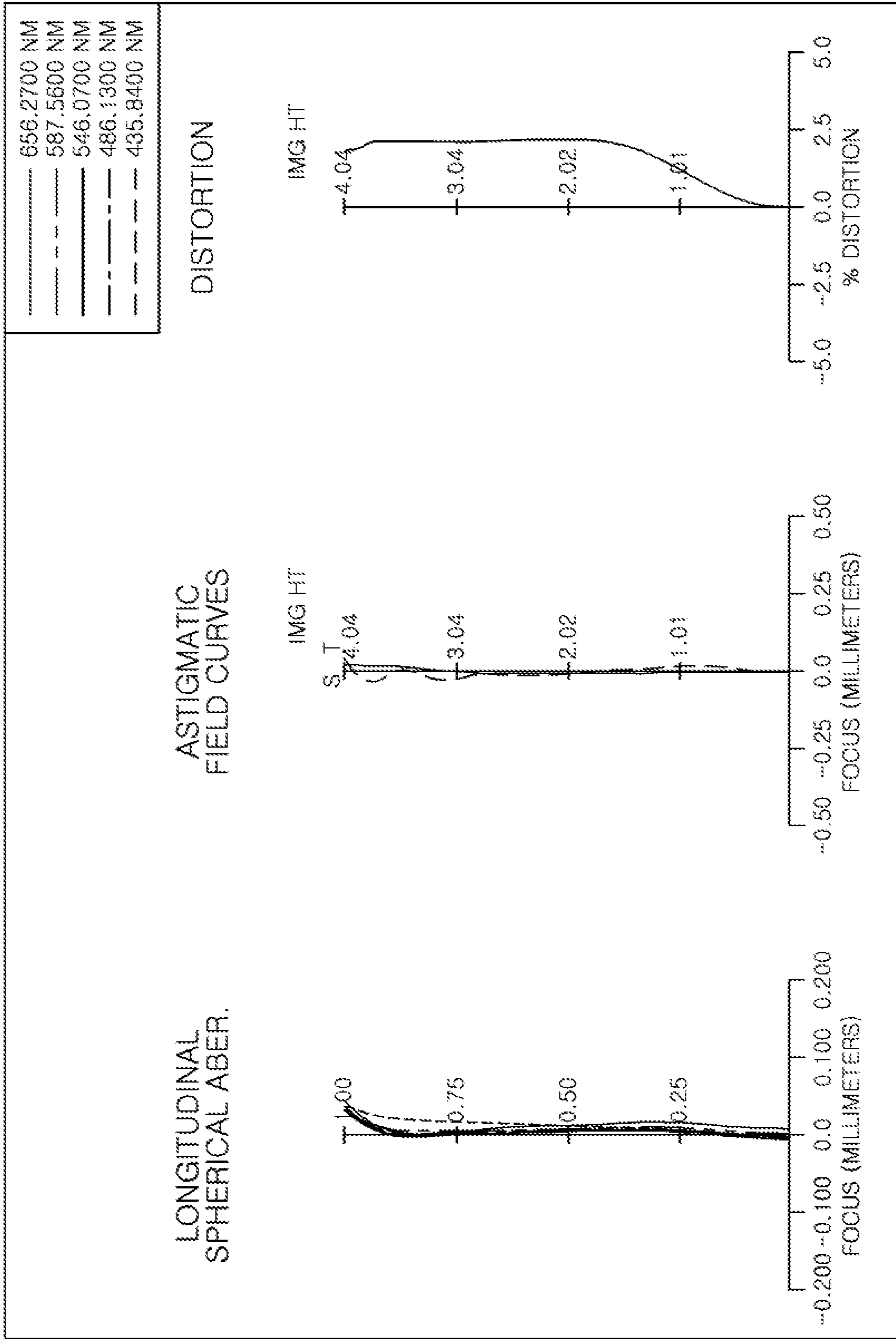

FIG. 6

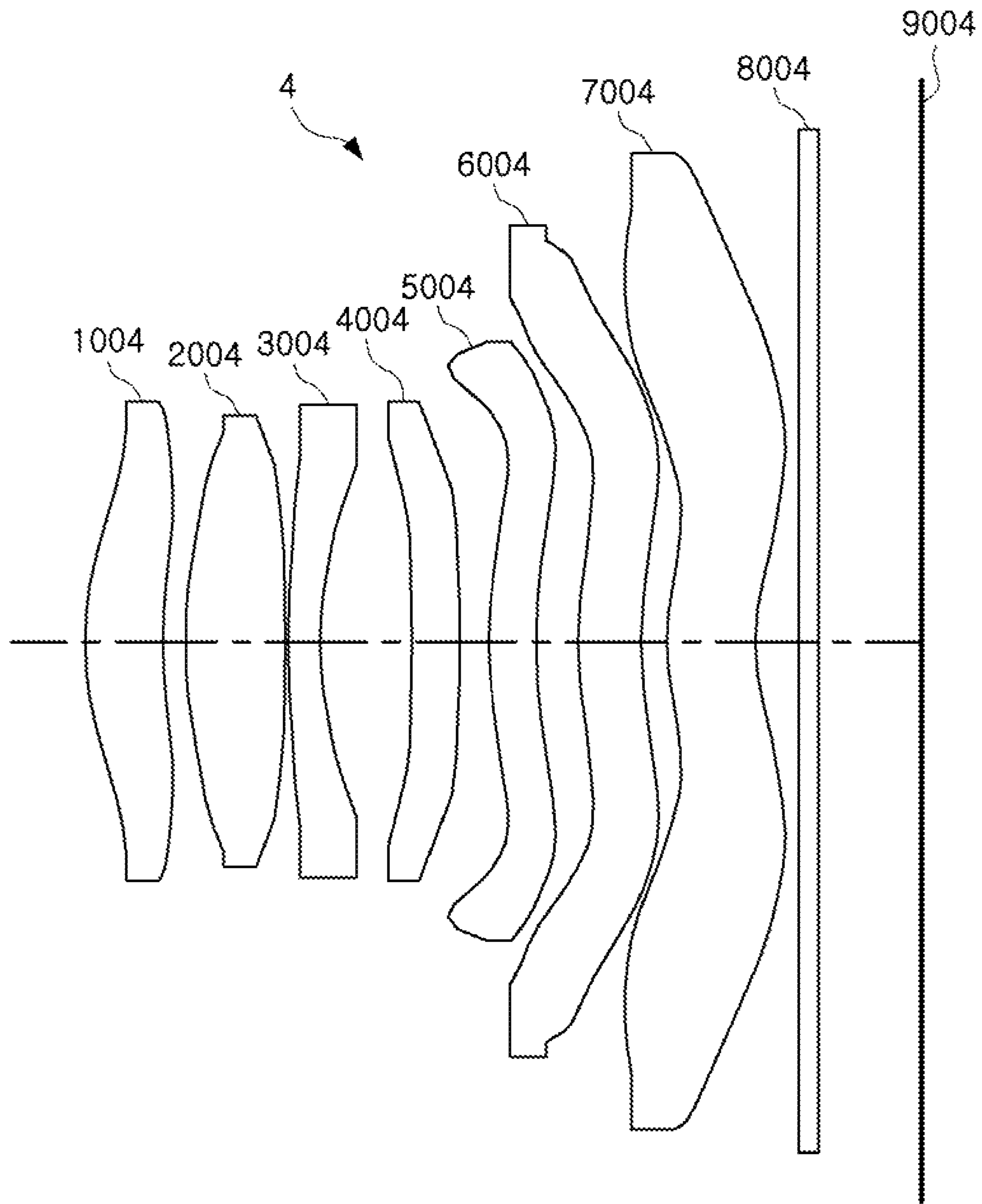

FIG. 7

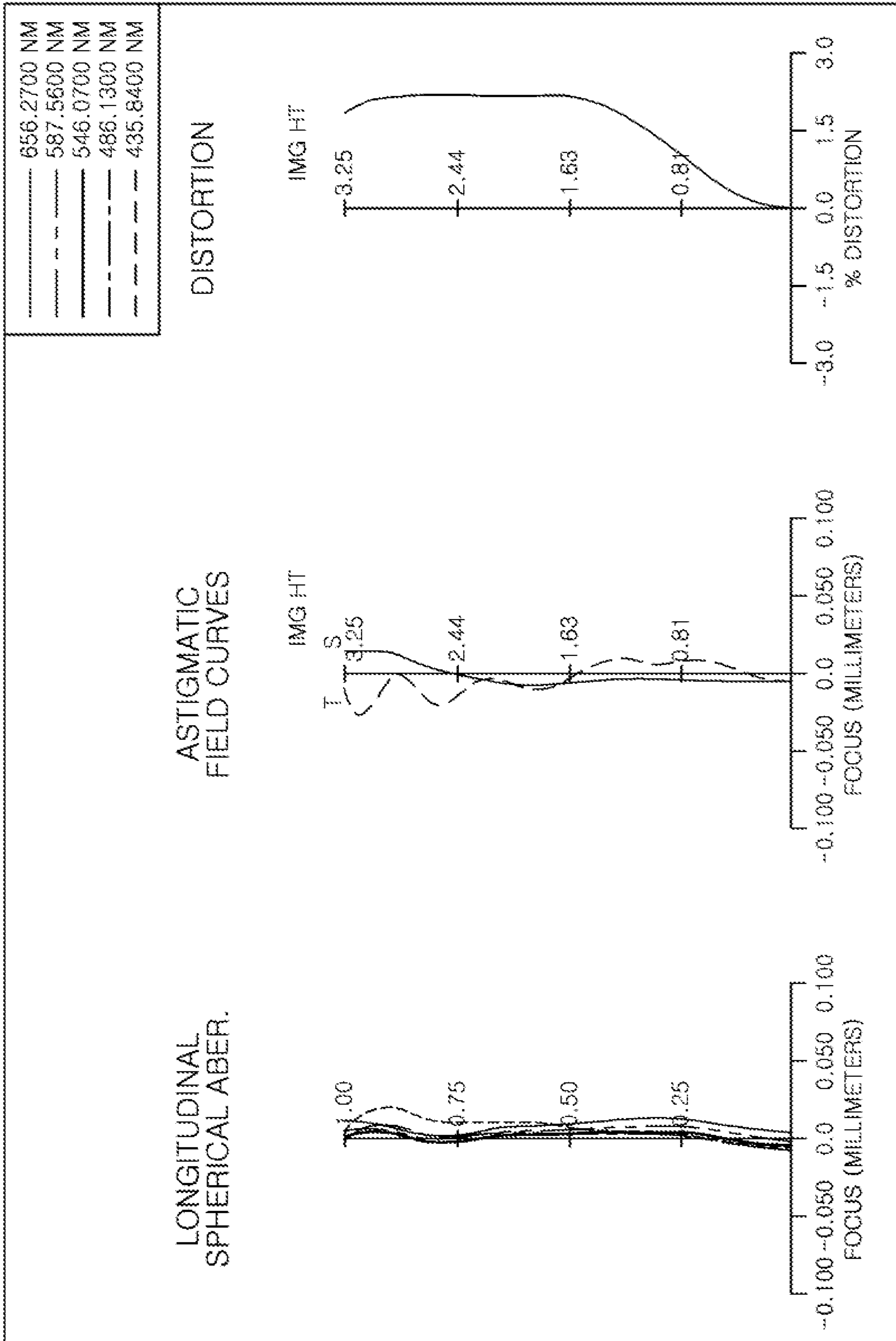

FIG. 8

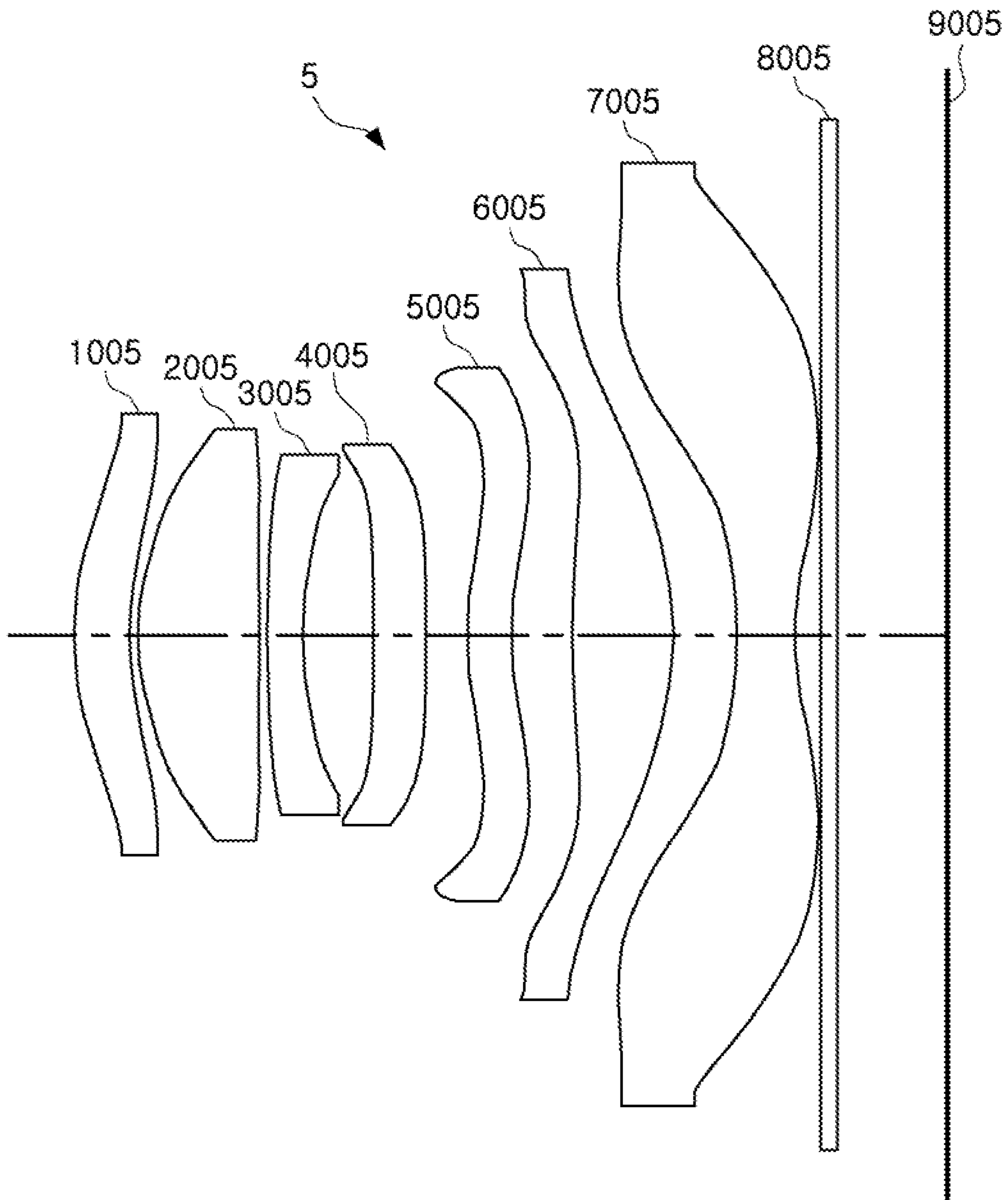

FIG. 9

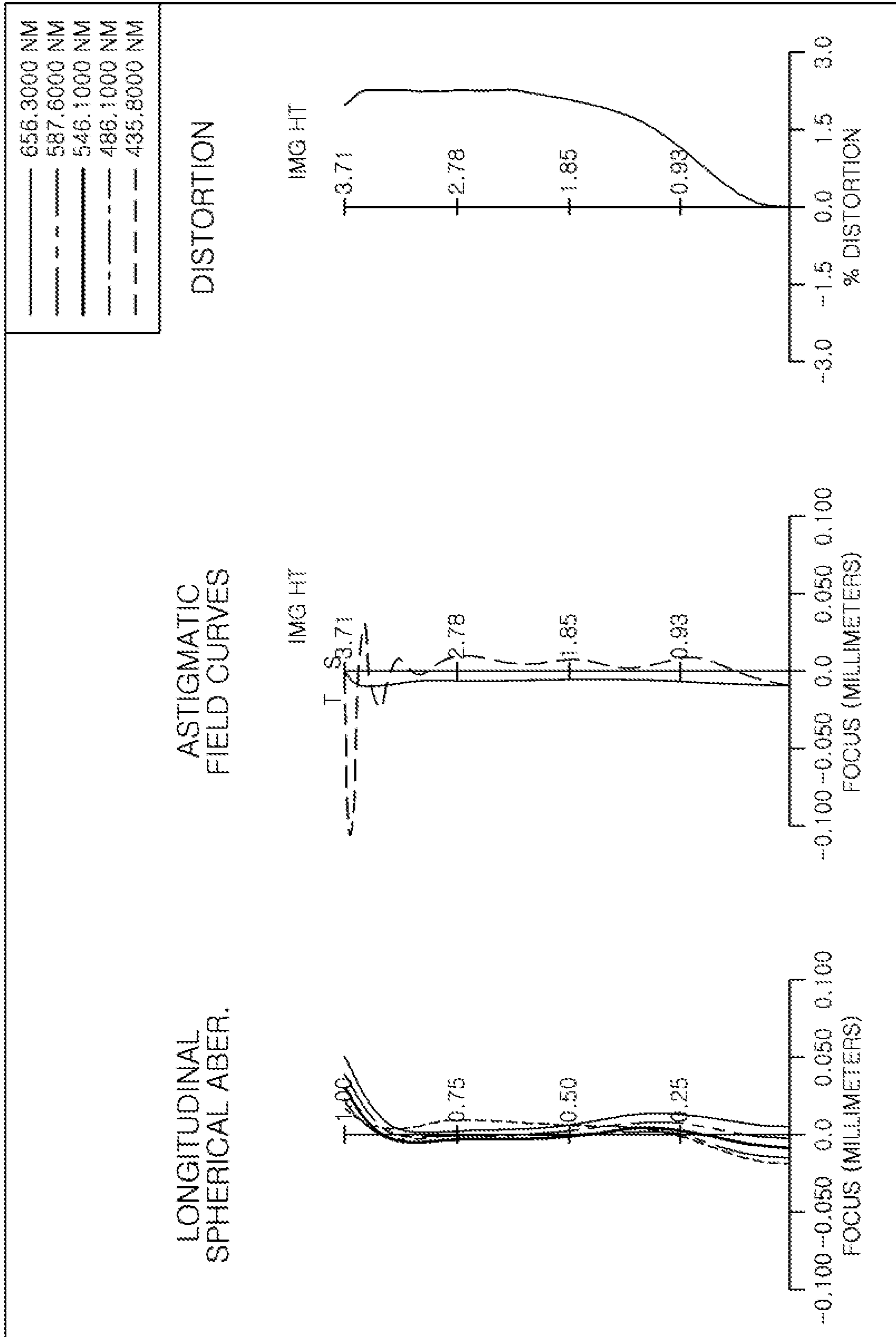

FIG. 10

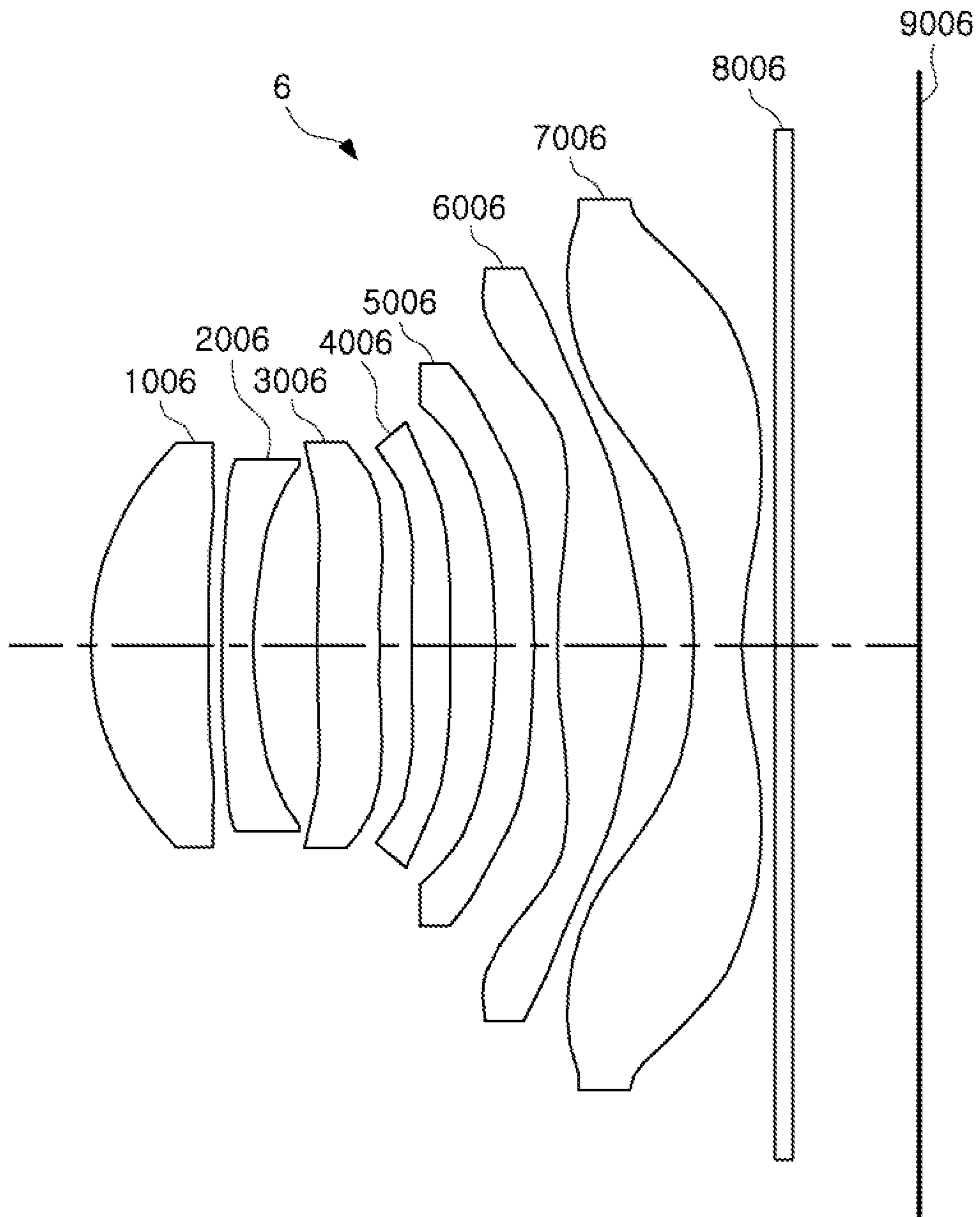

FIG. 11

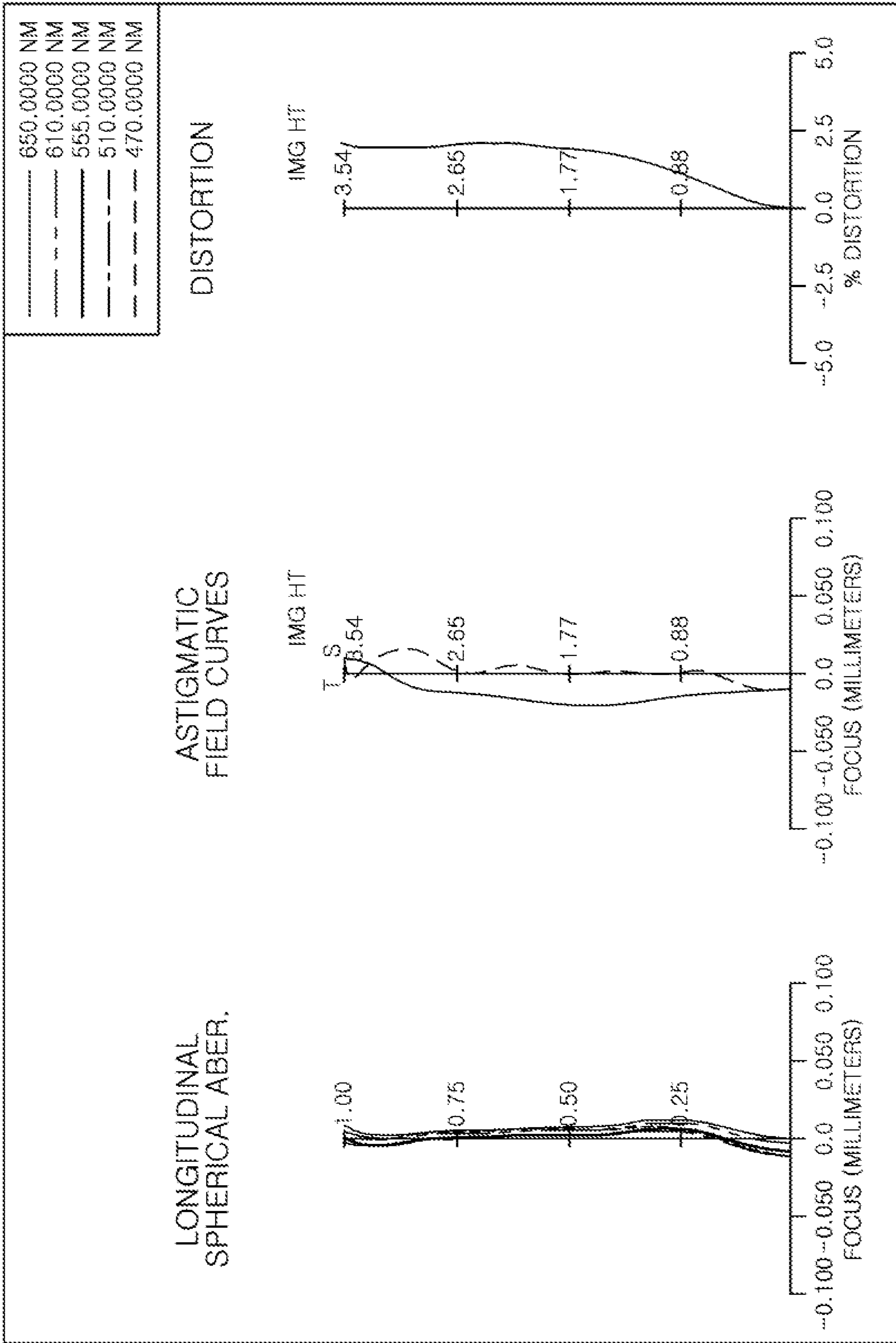

FIG. 12

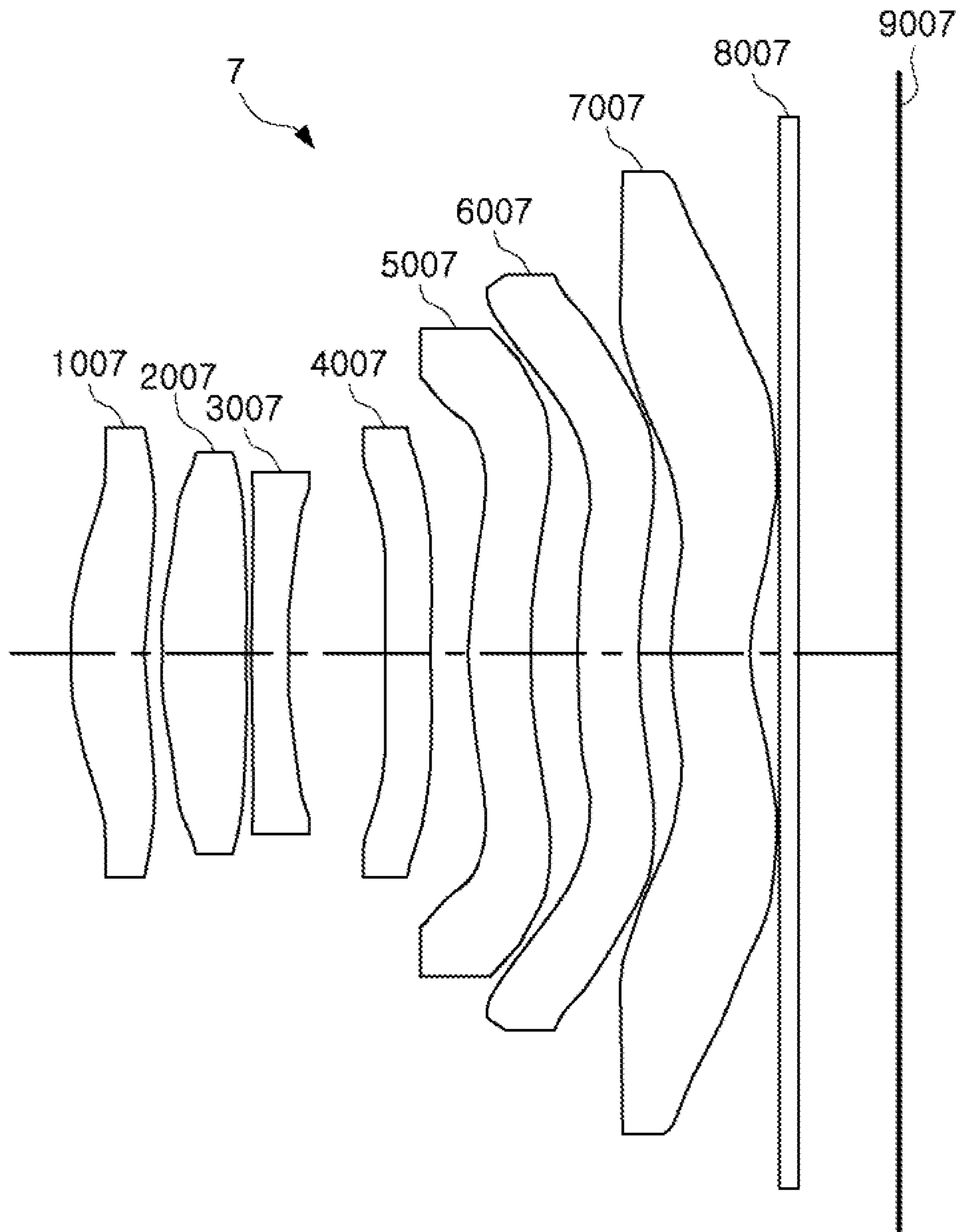

FIG. 13

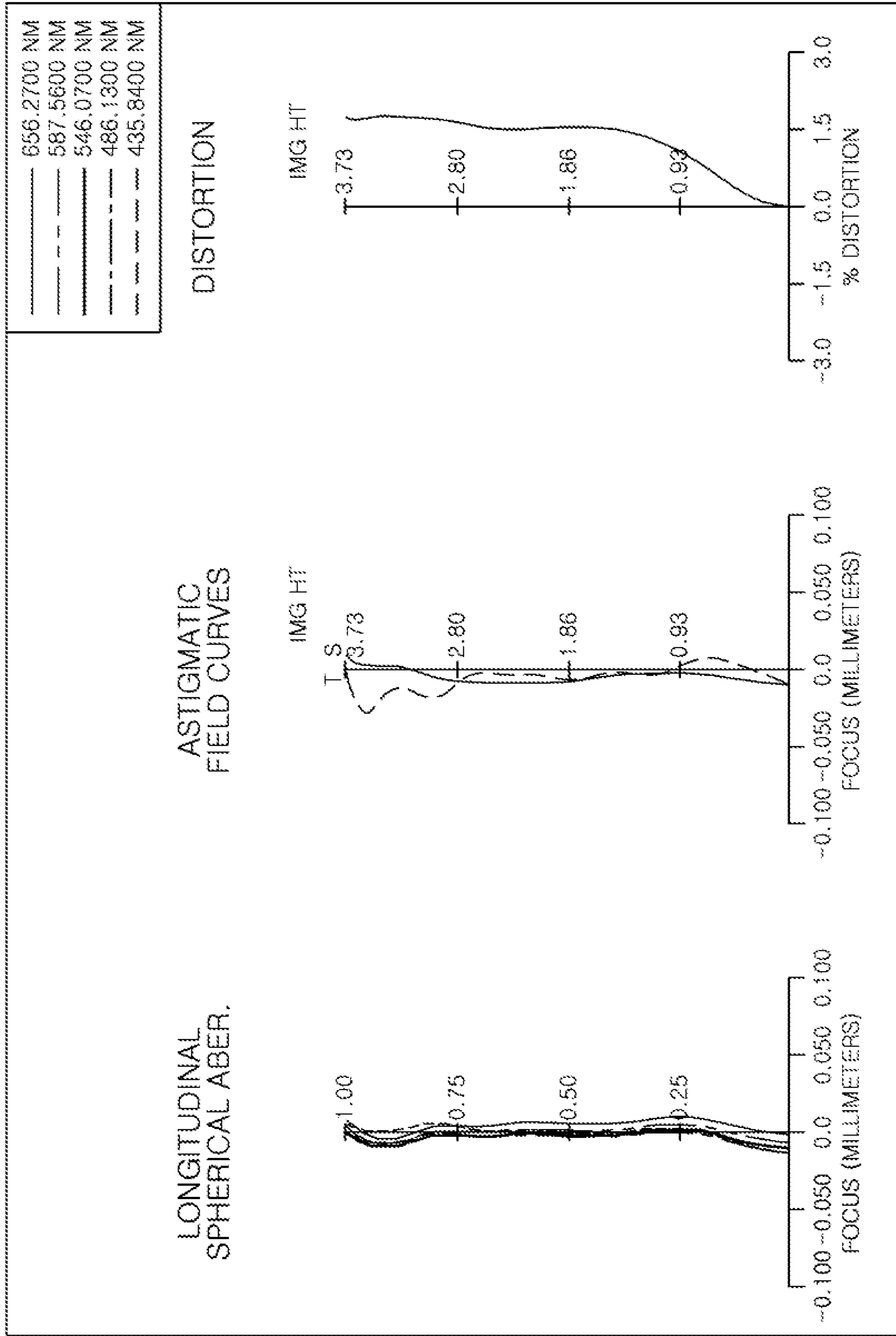

FIG. 14

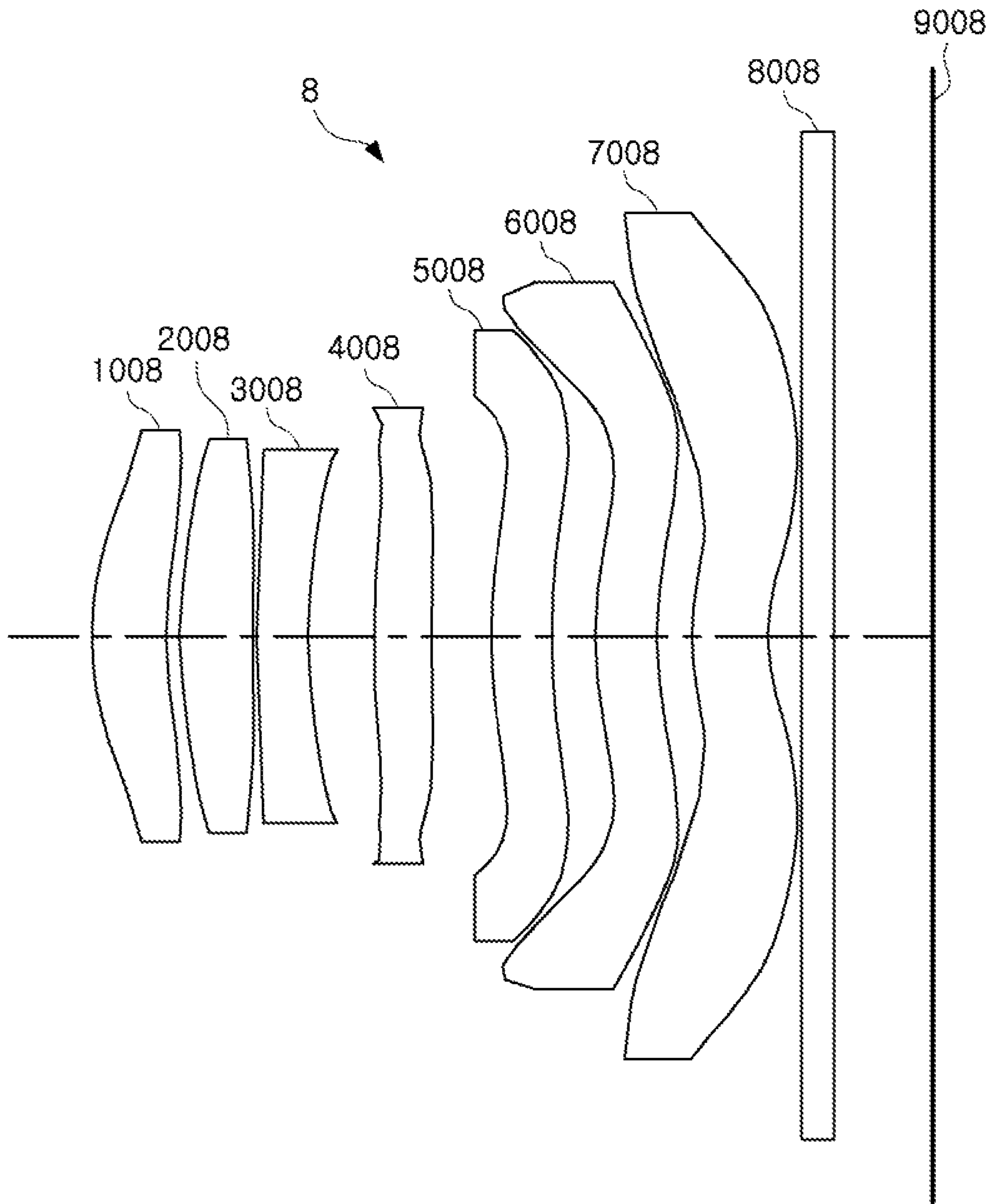

FIG. 15

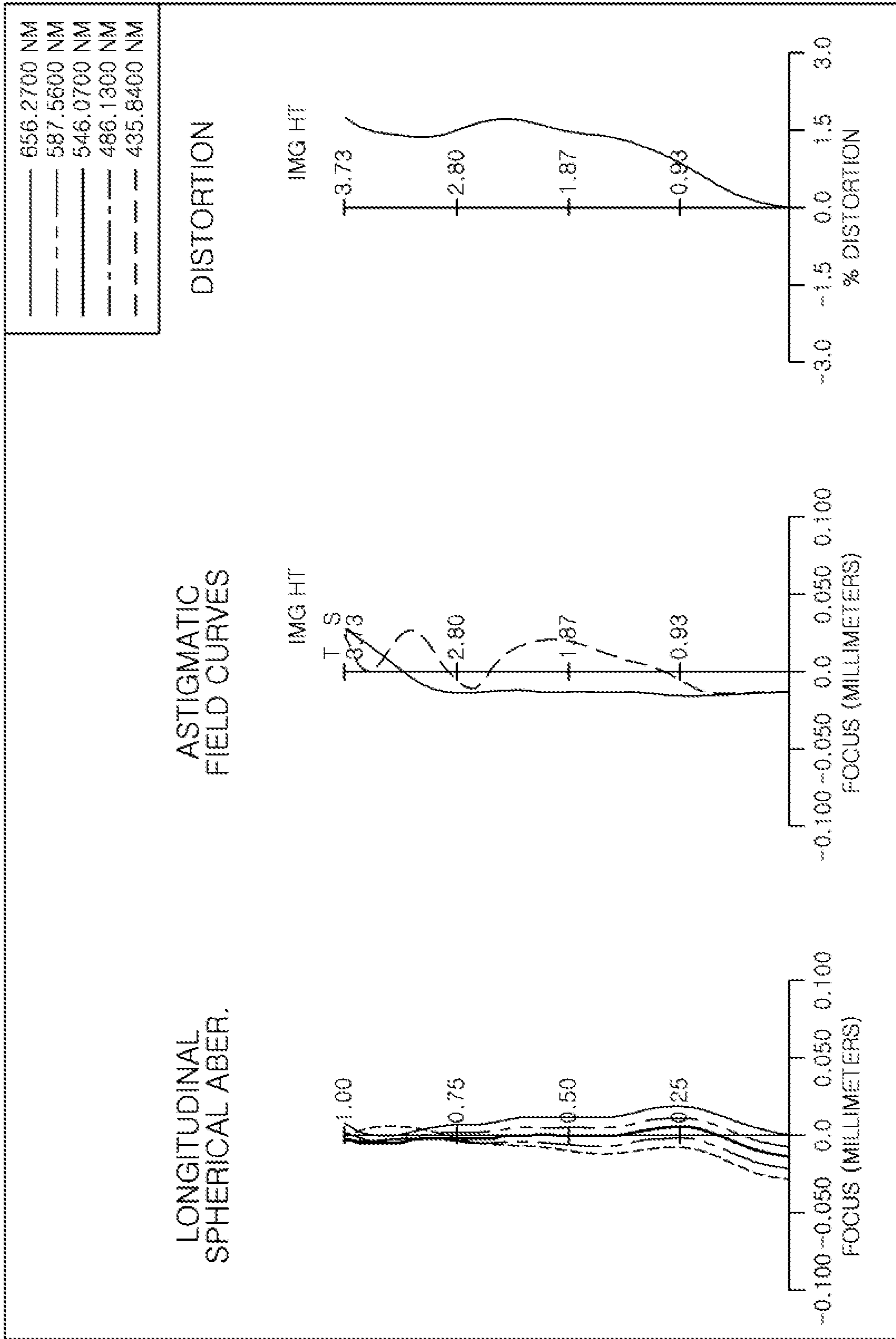

FIG. 16

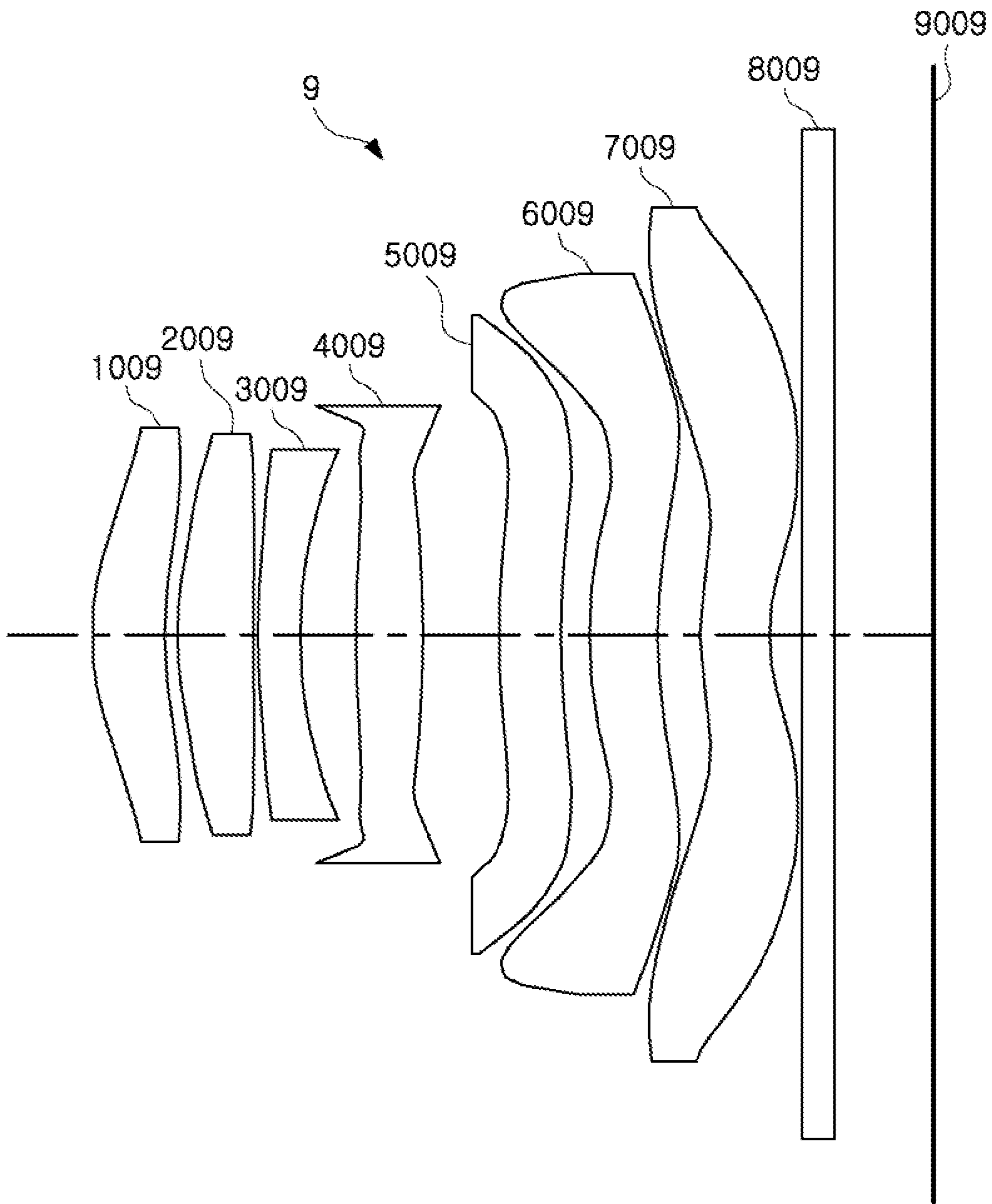

FIG. 17

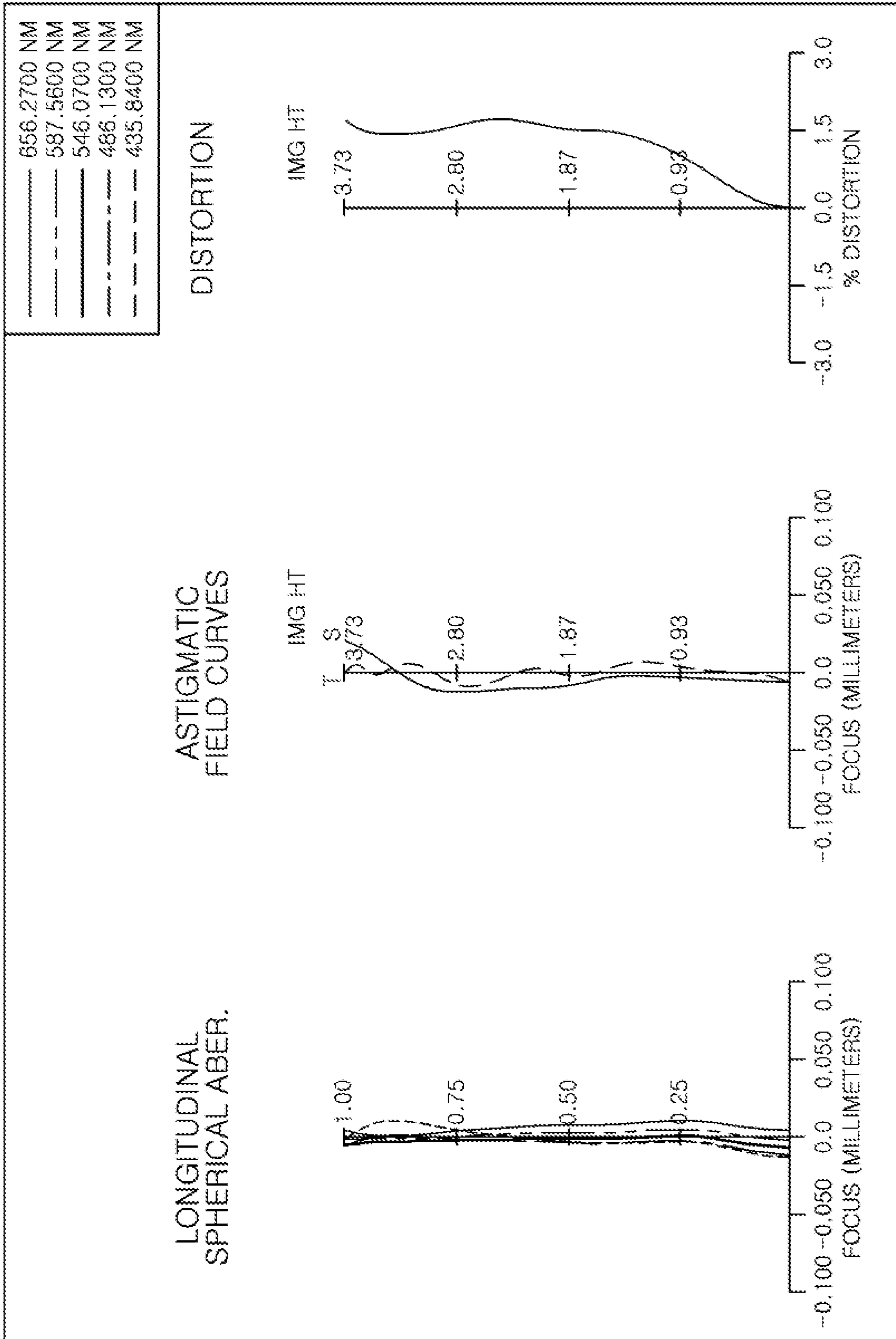

FIG. 18

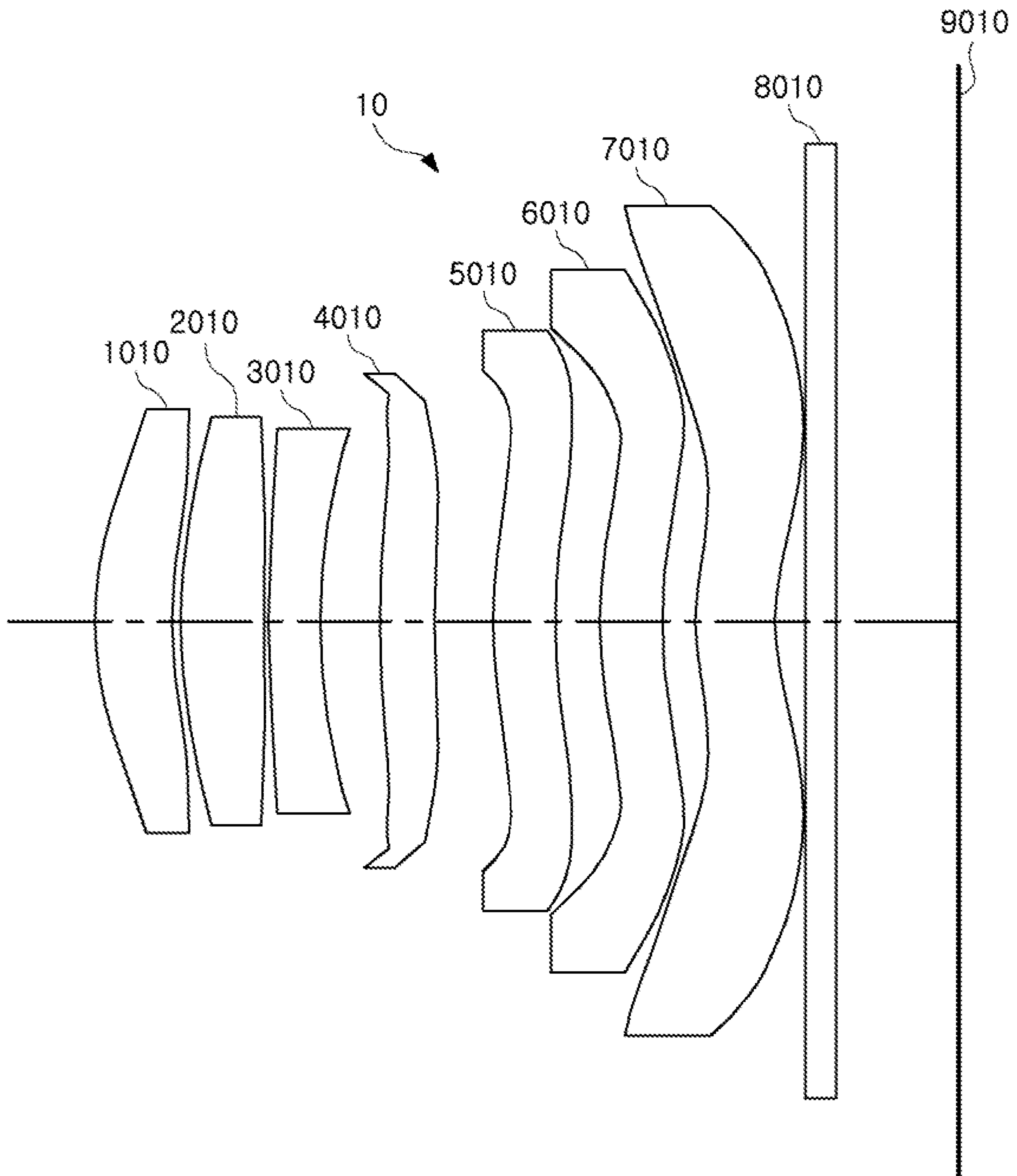

FIG. 19

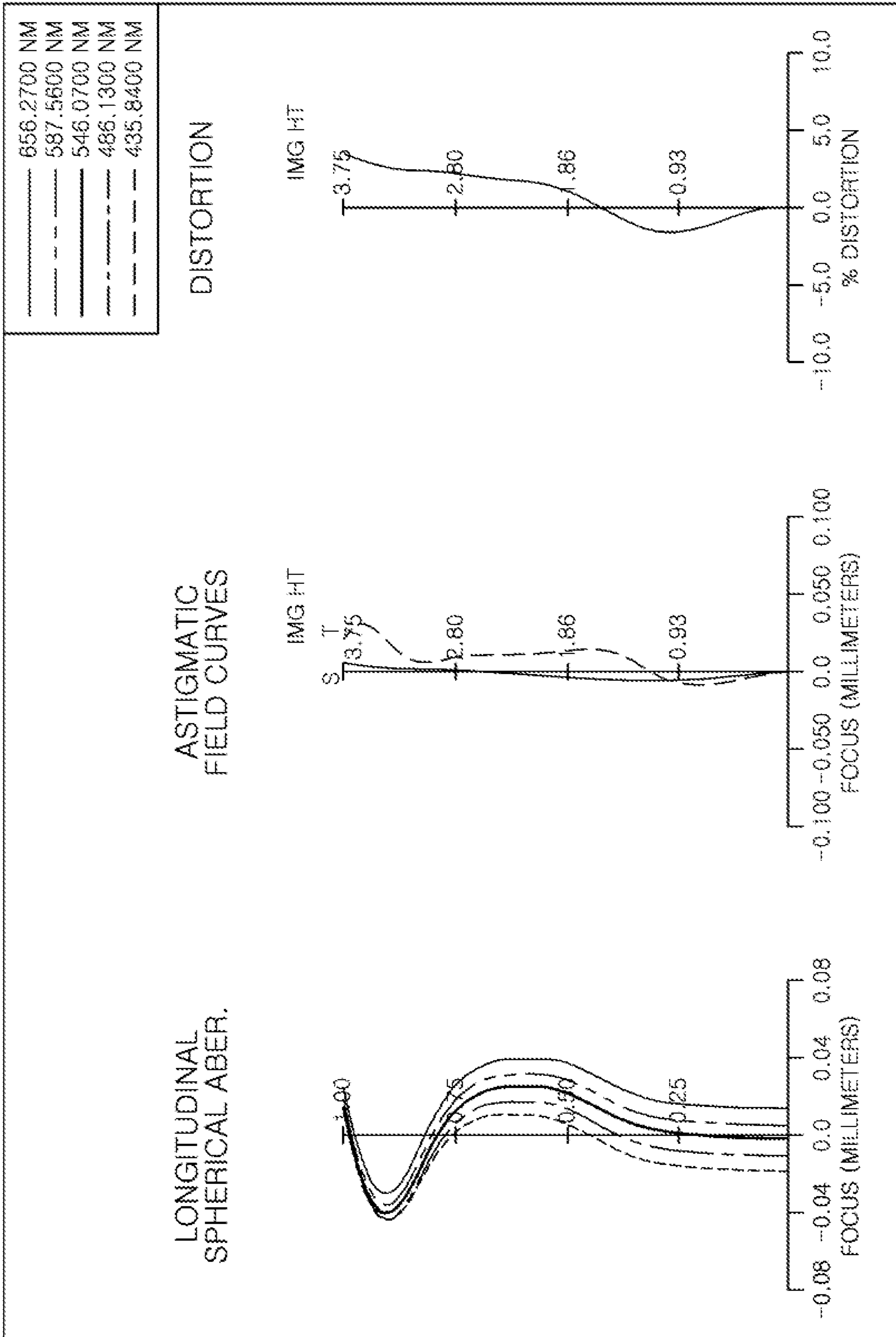

FIG. 20

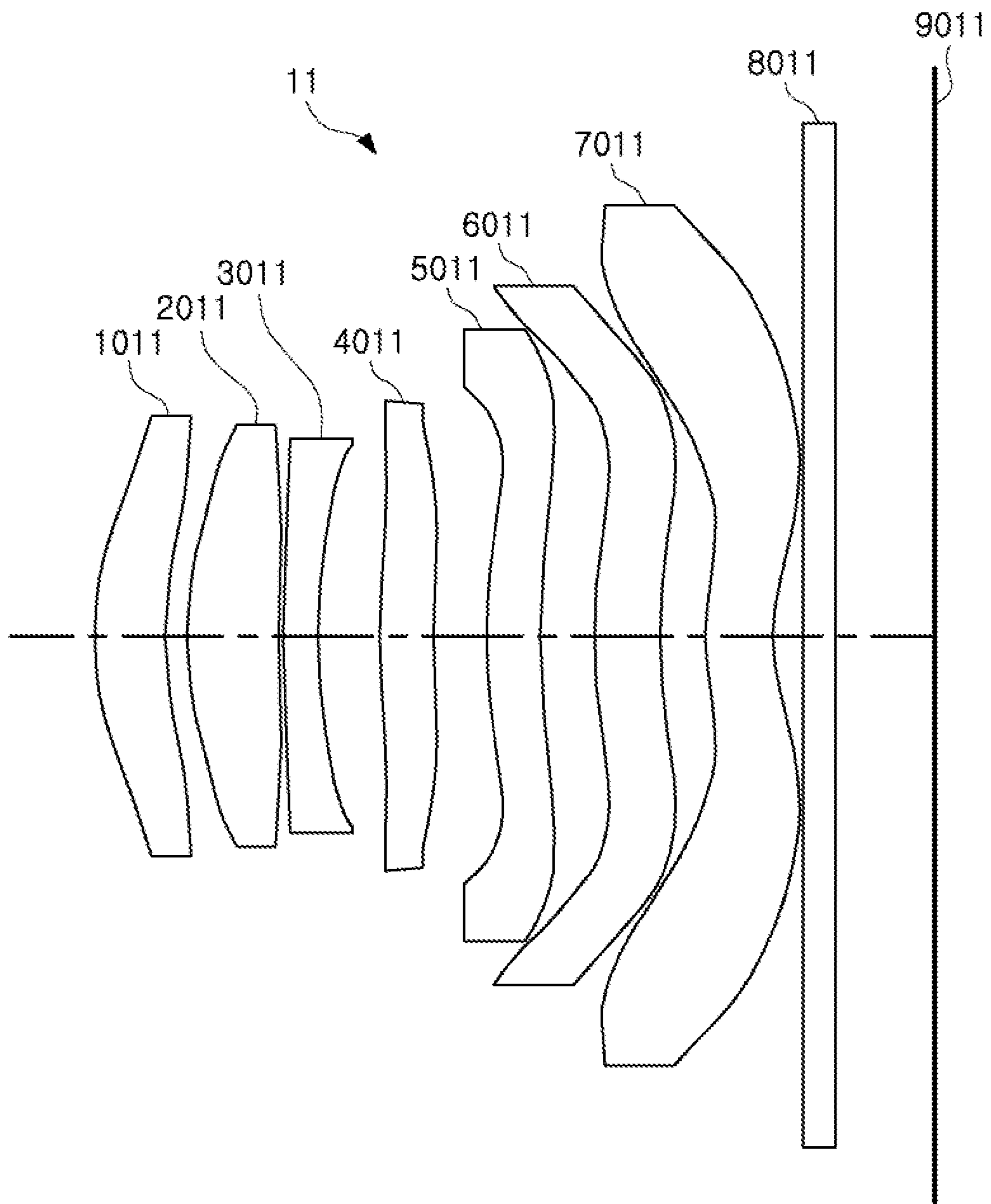

FIG. 21

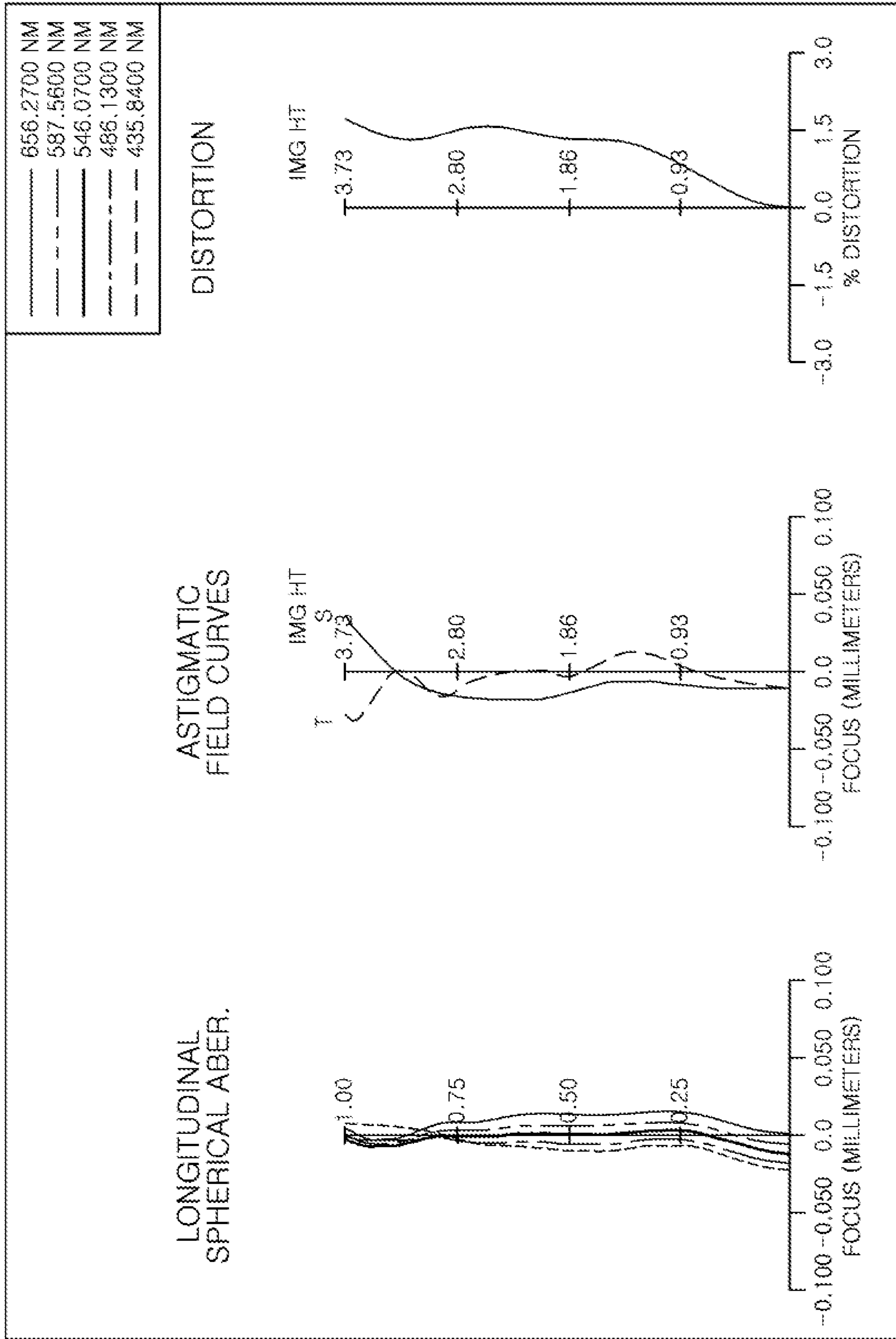

FIG. 22

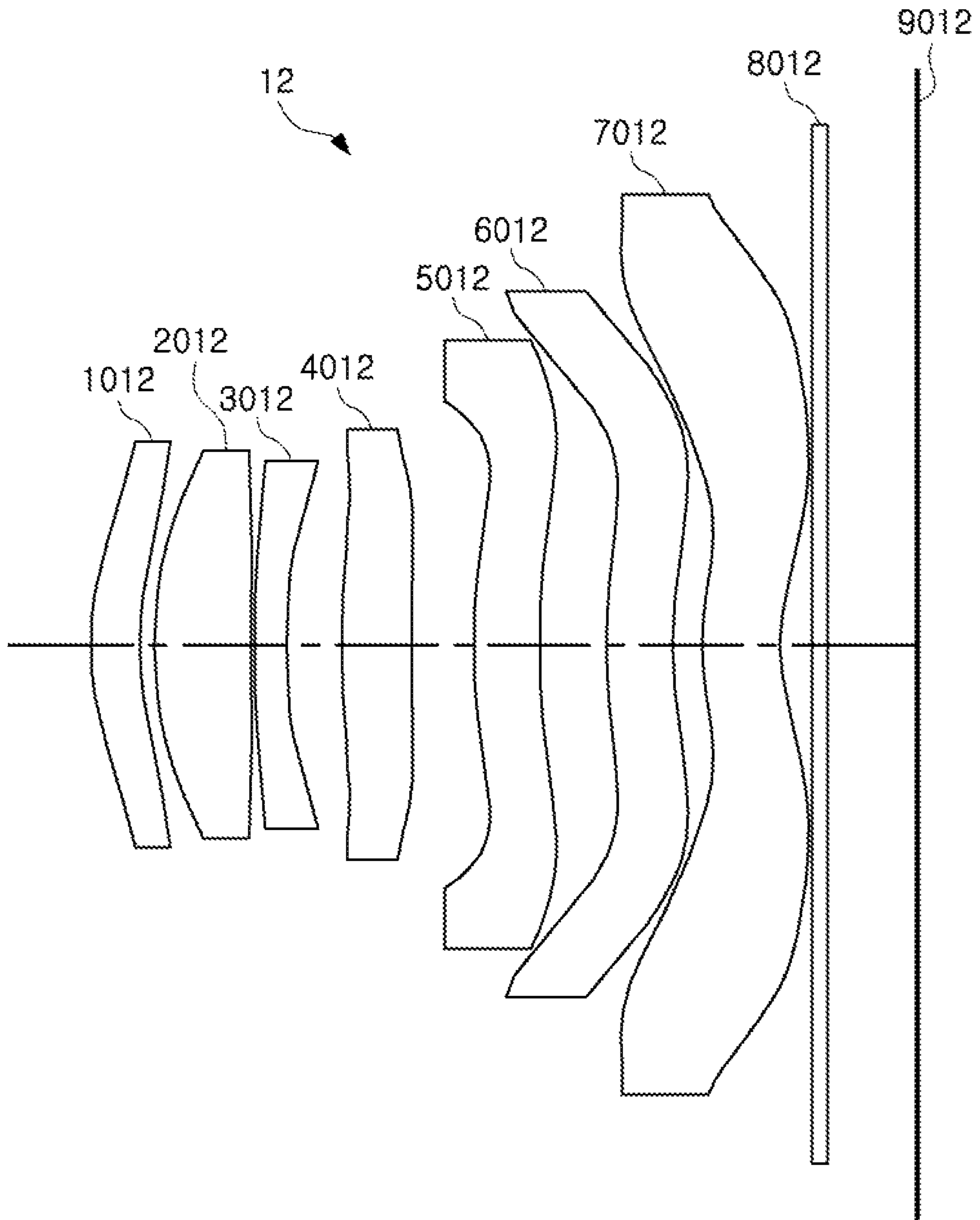

FIG. 23

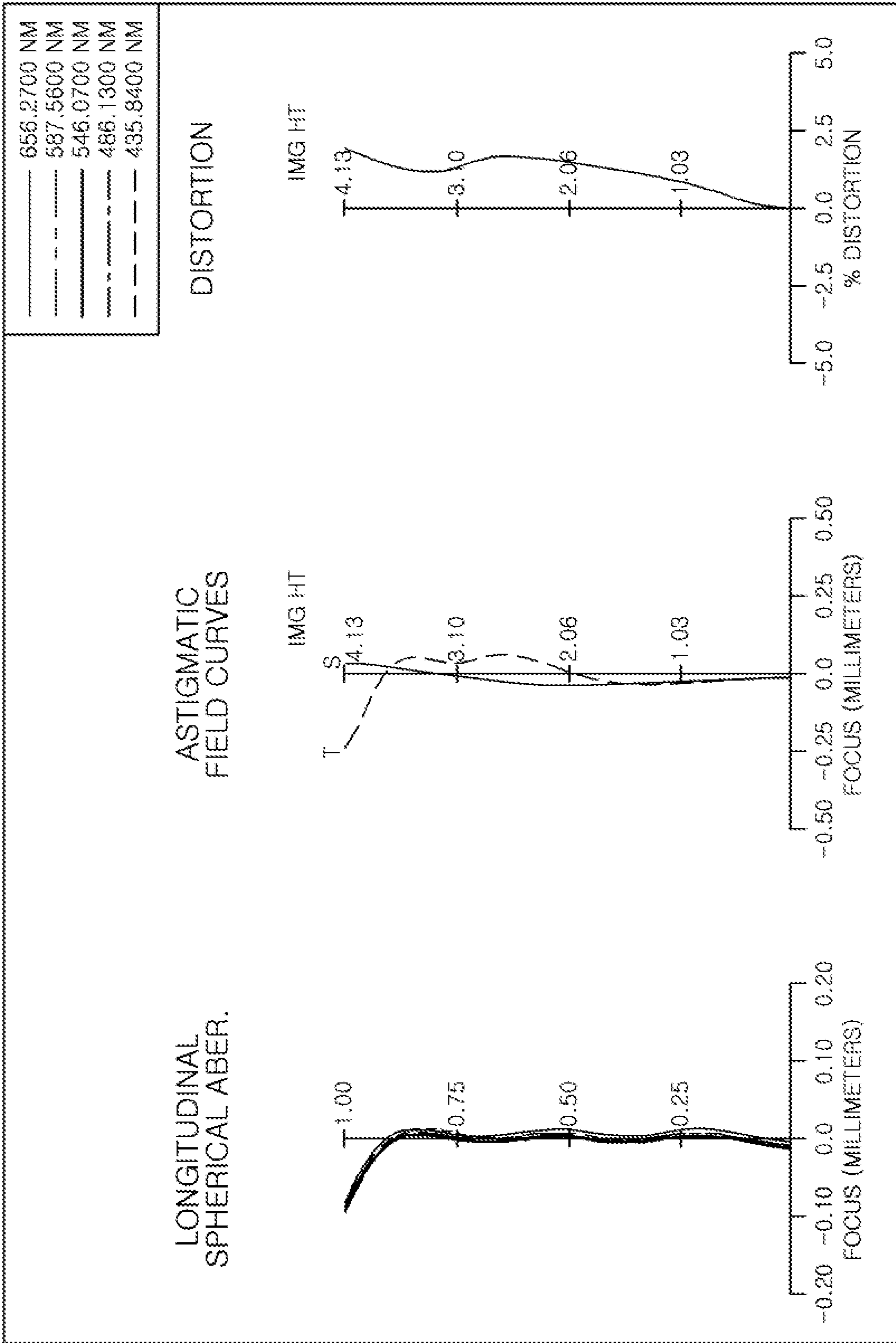

FIG. 24

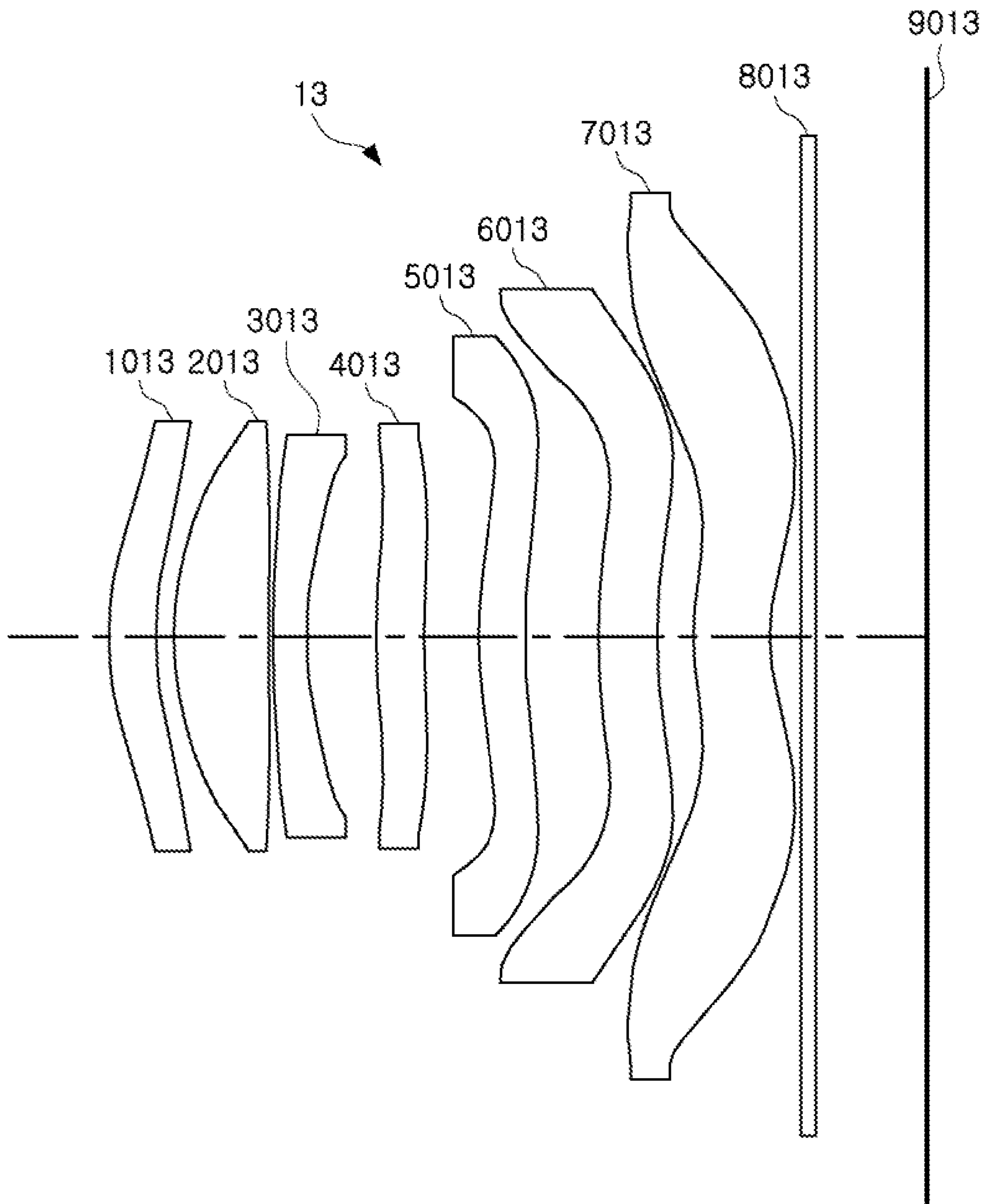

FIG. 25

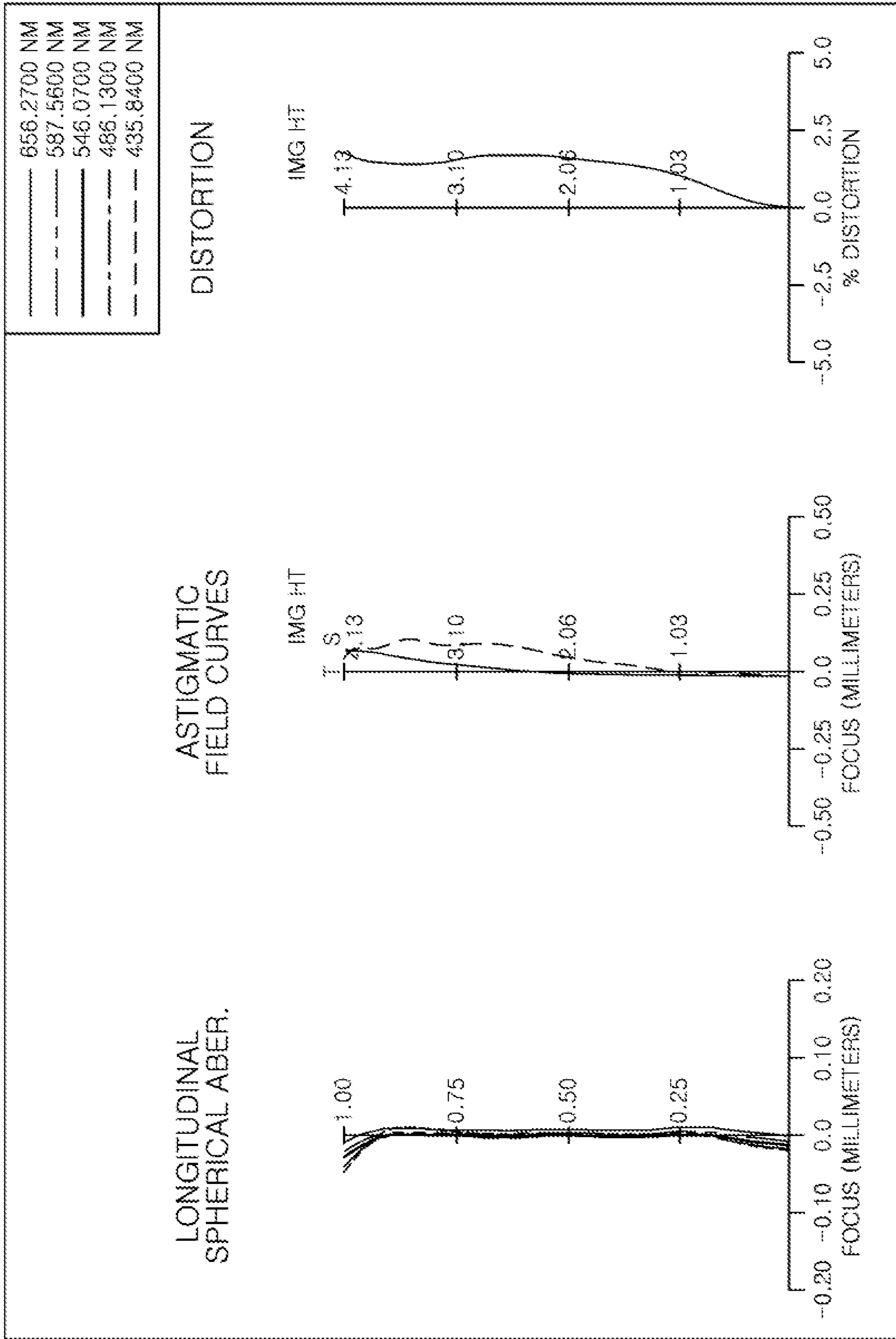

FIG. 26

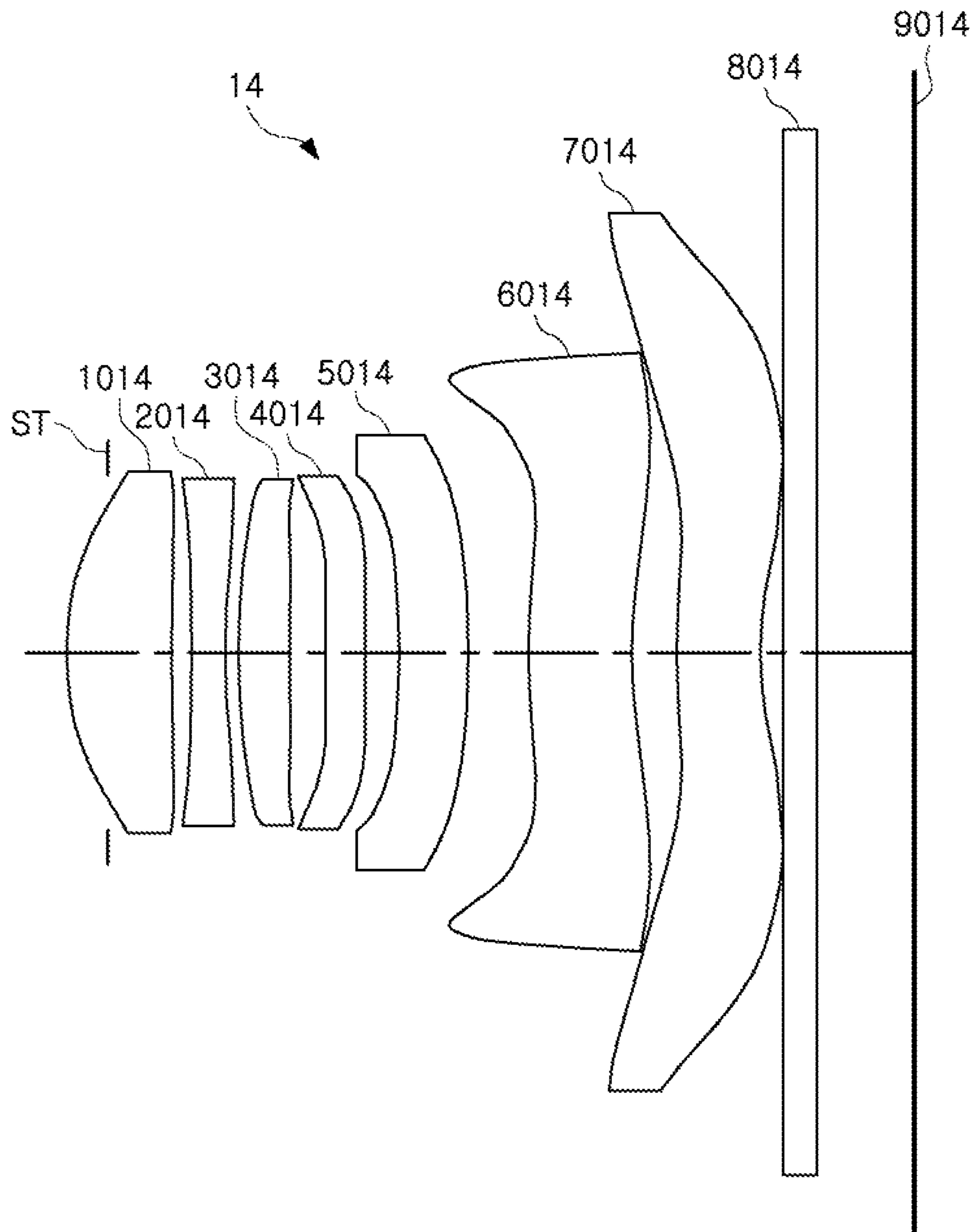

FIG. 27

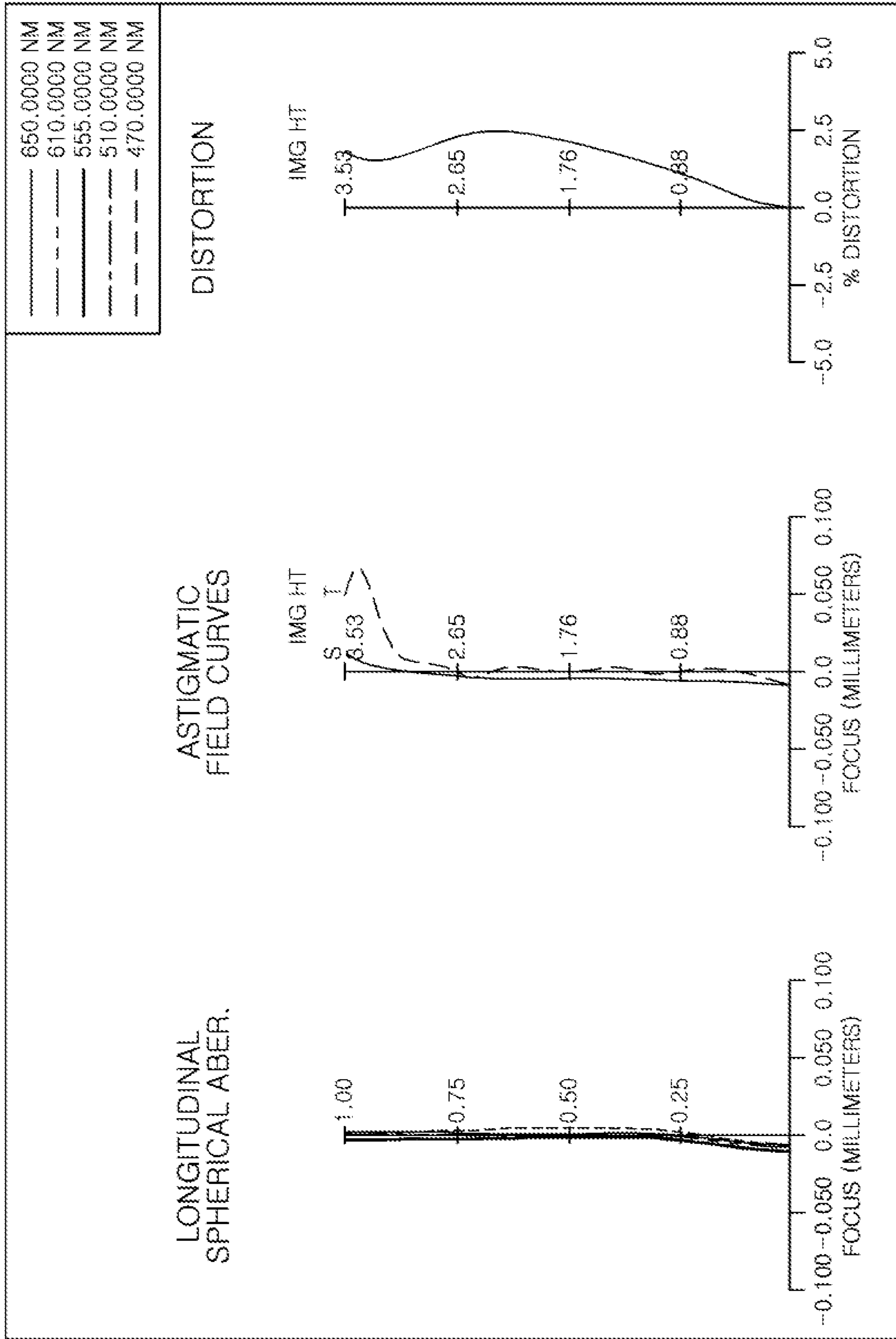

FIG. 28

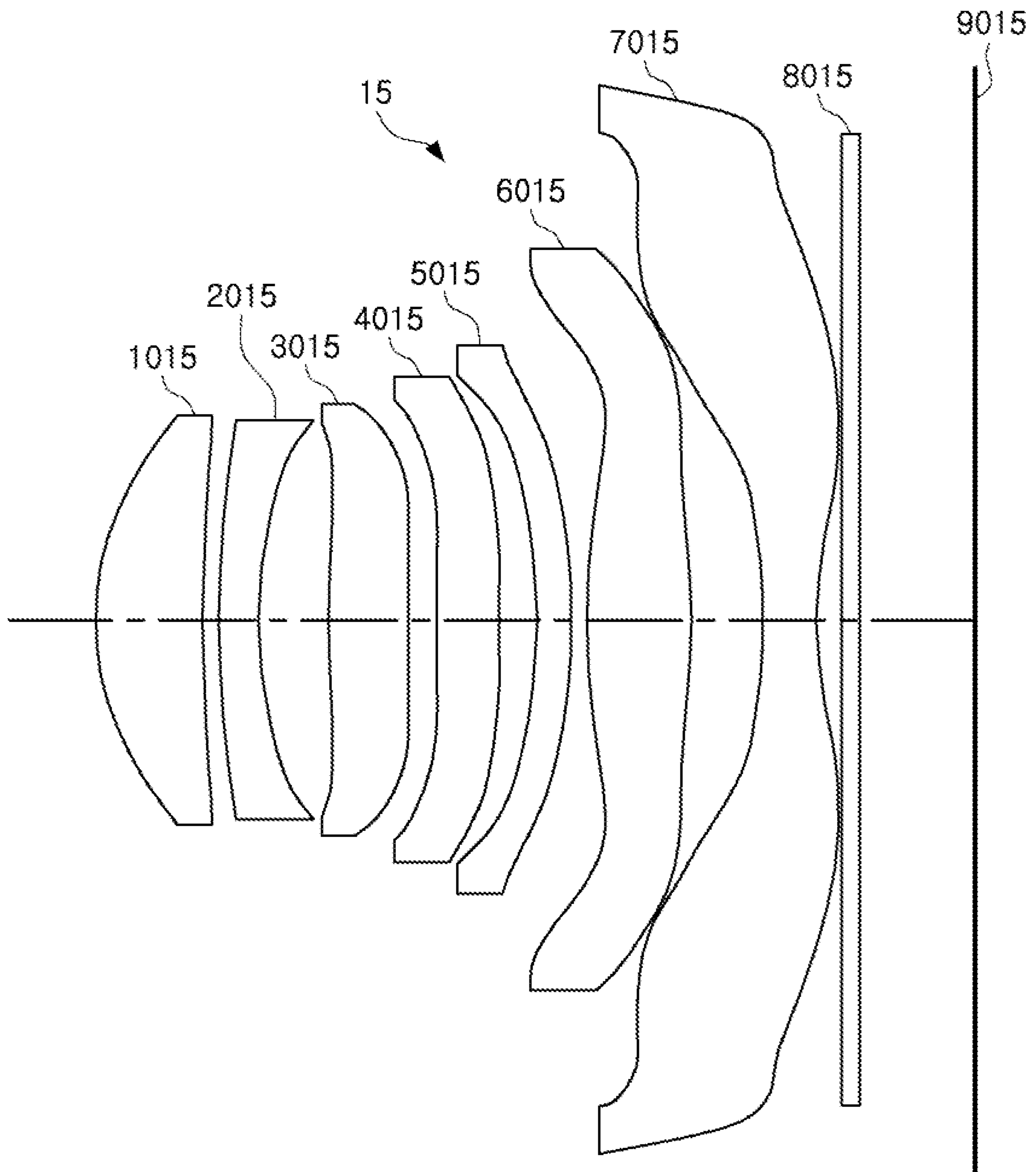

FIG. 29

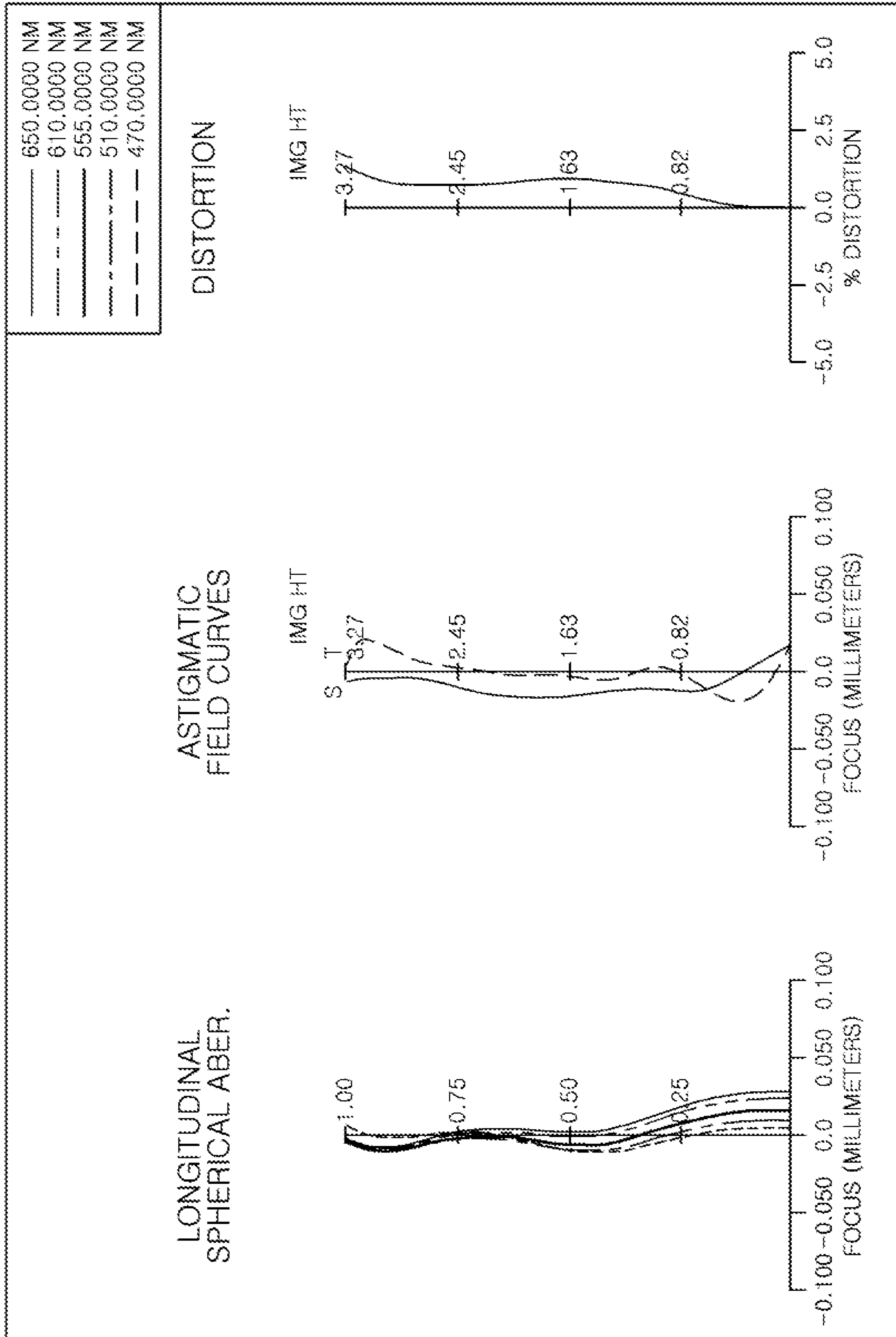

FIG. 30

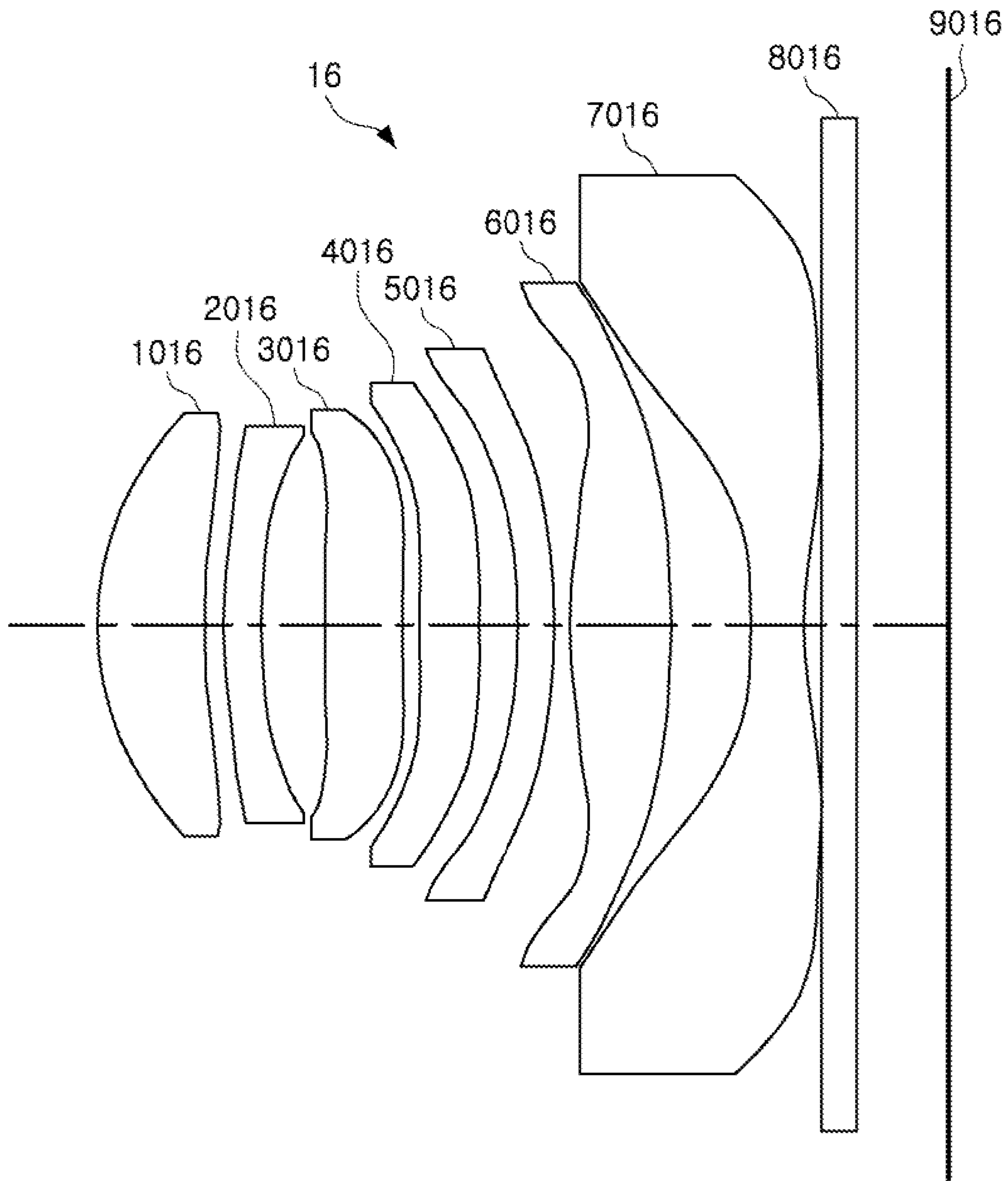

FIG. 31

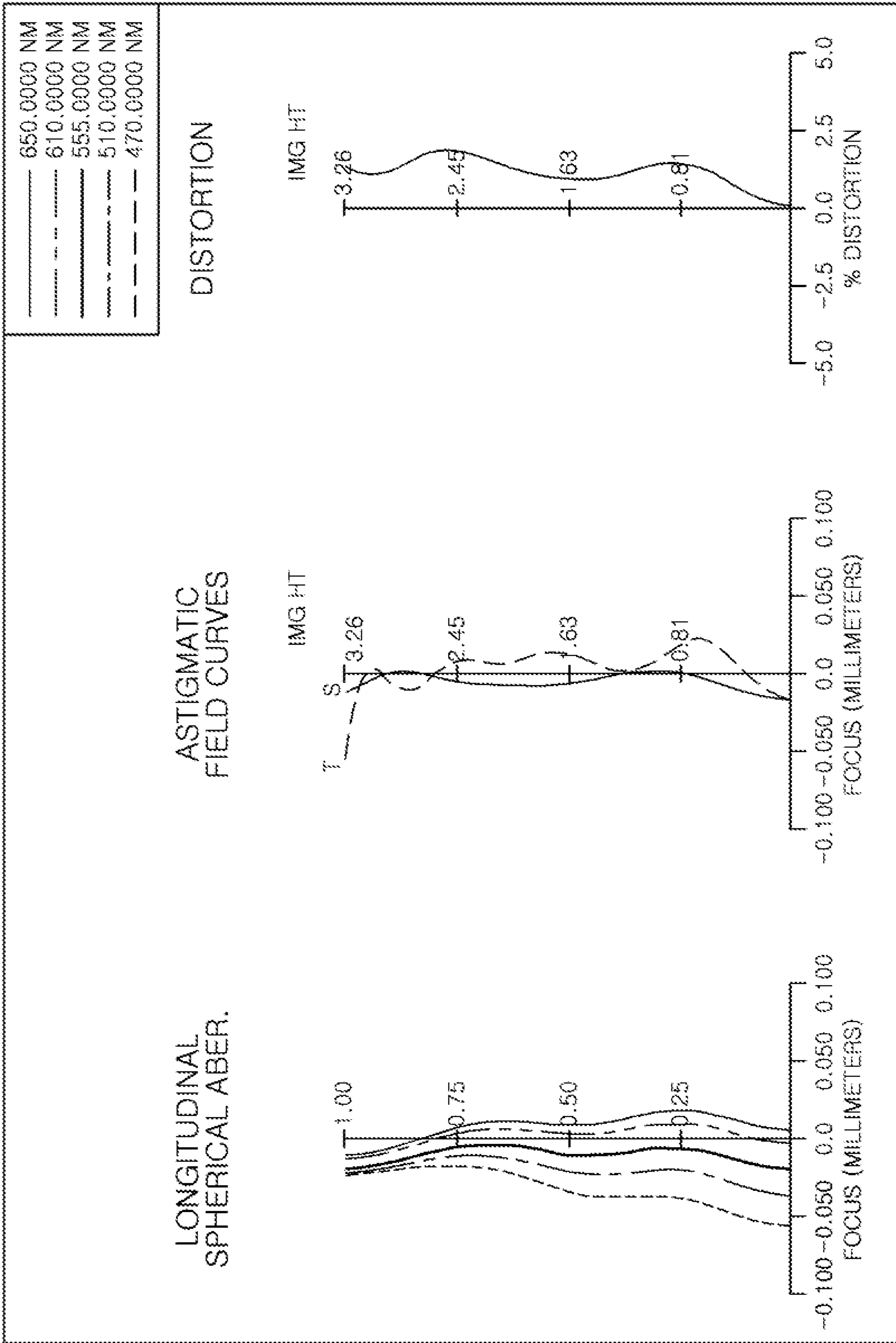

FIG. 32

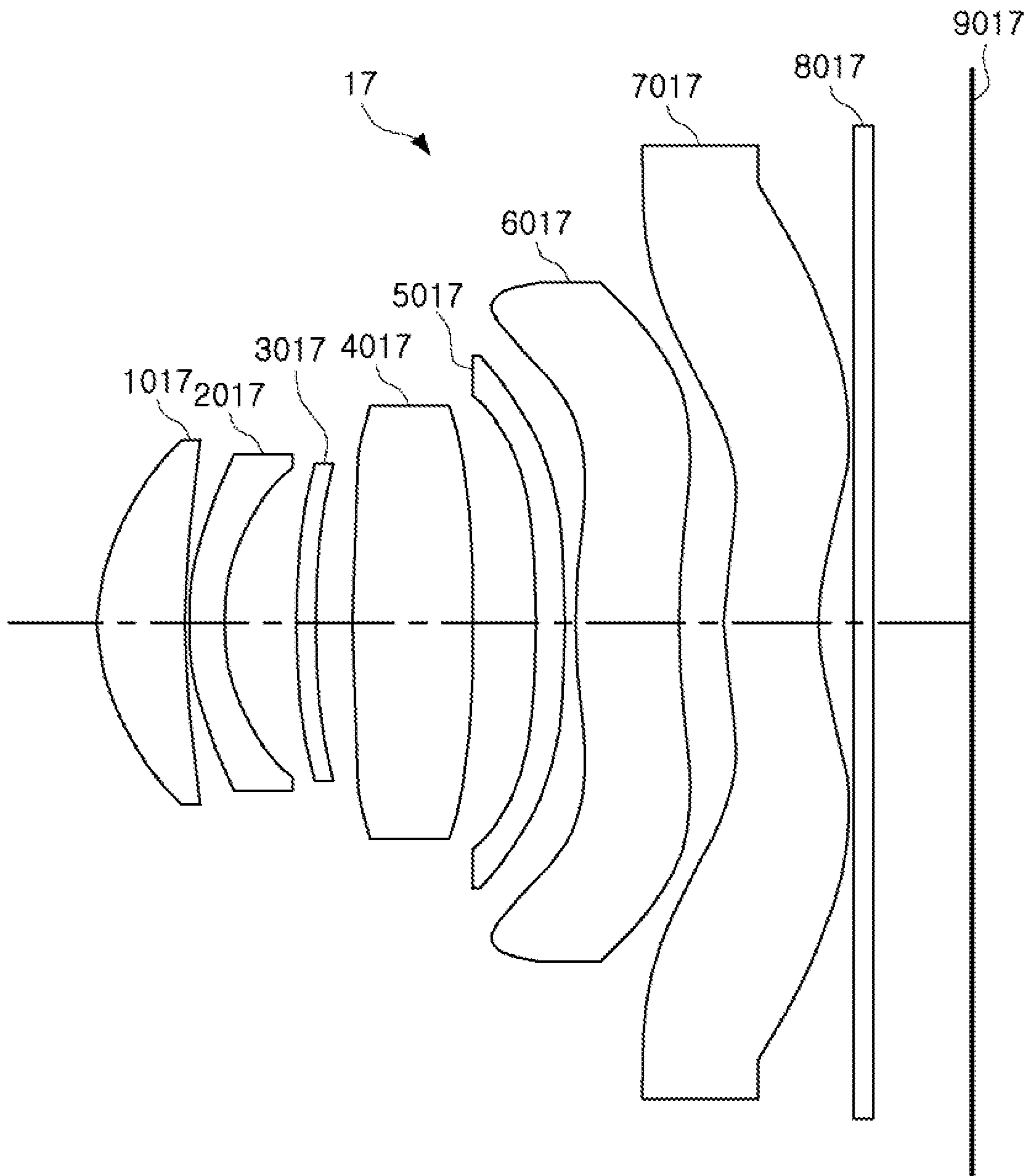

FIG. 33

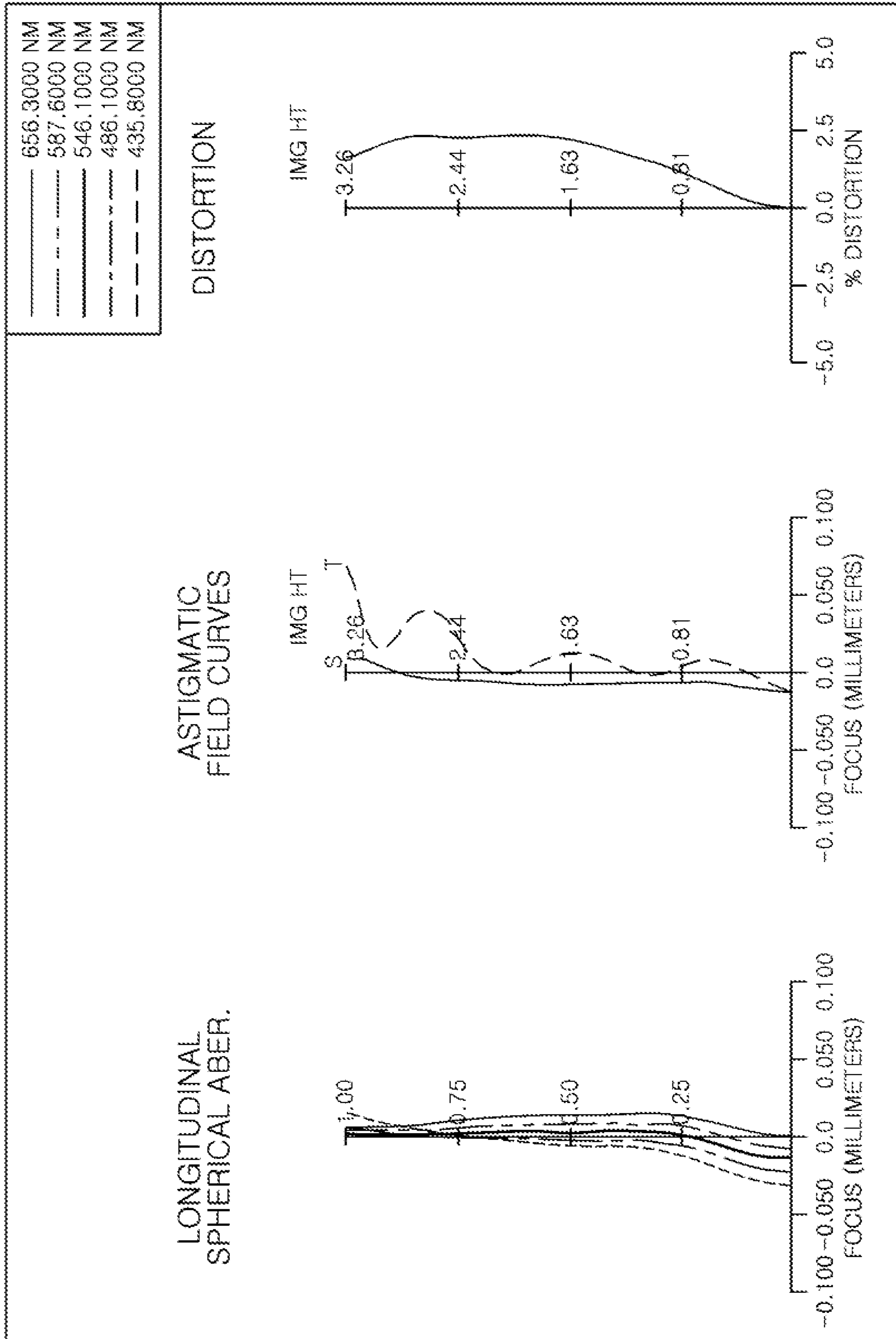

FIG. 34

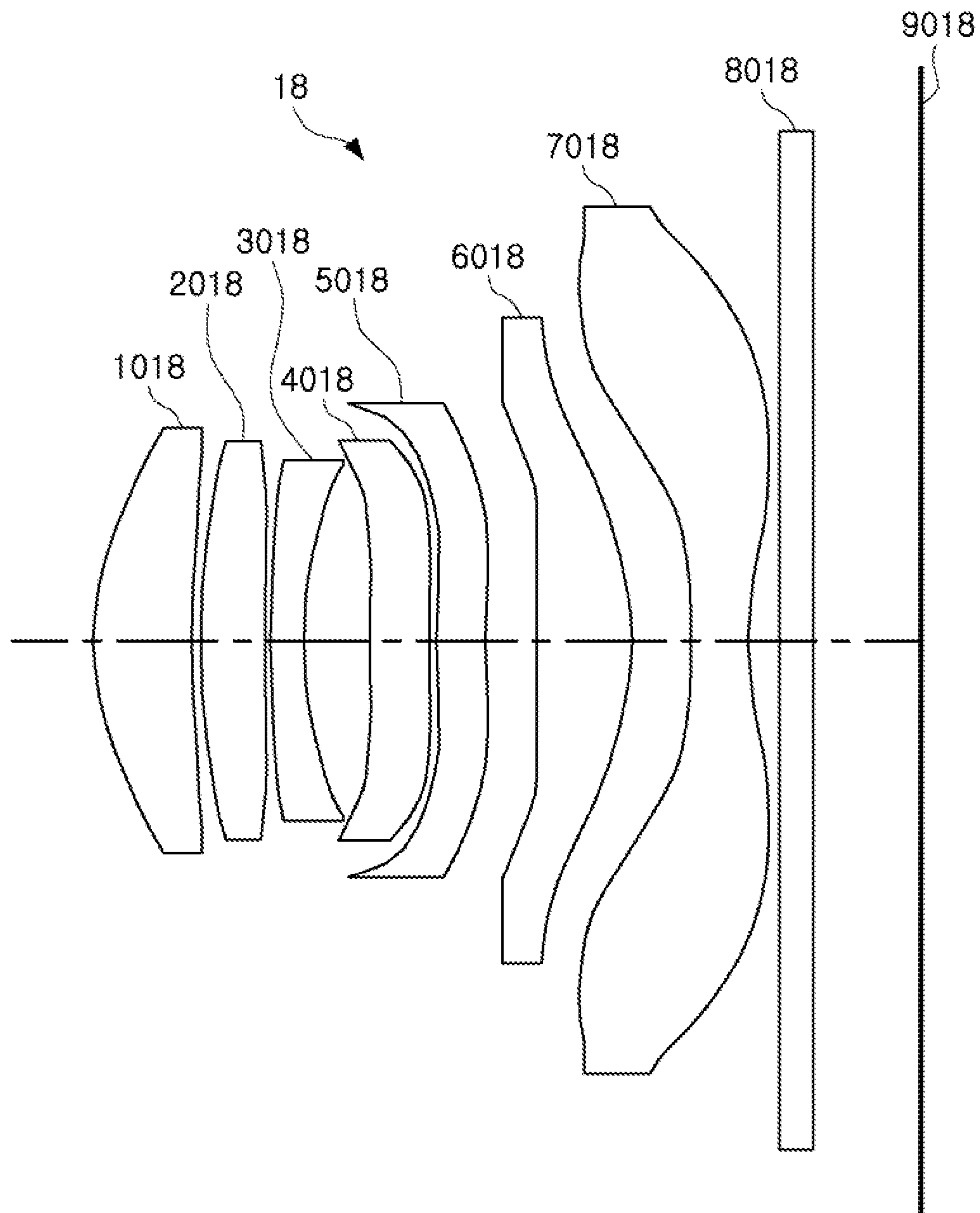

FIG. 35

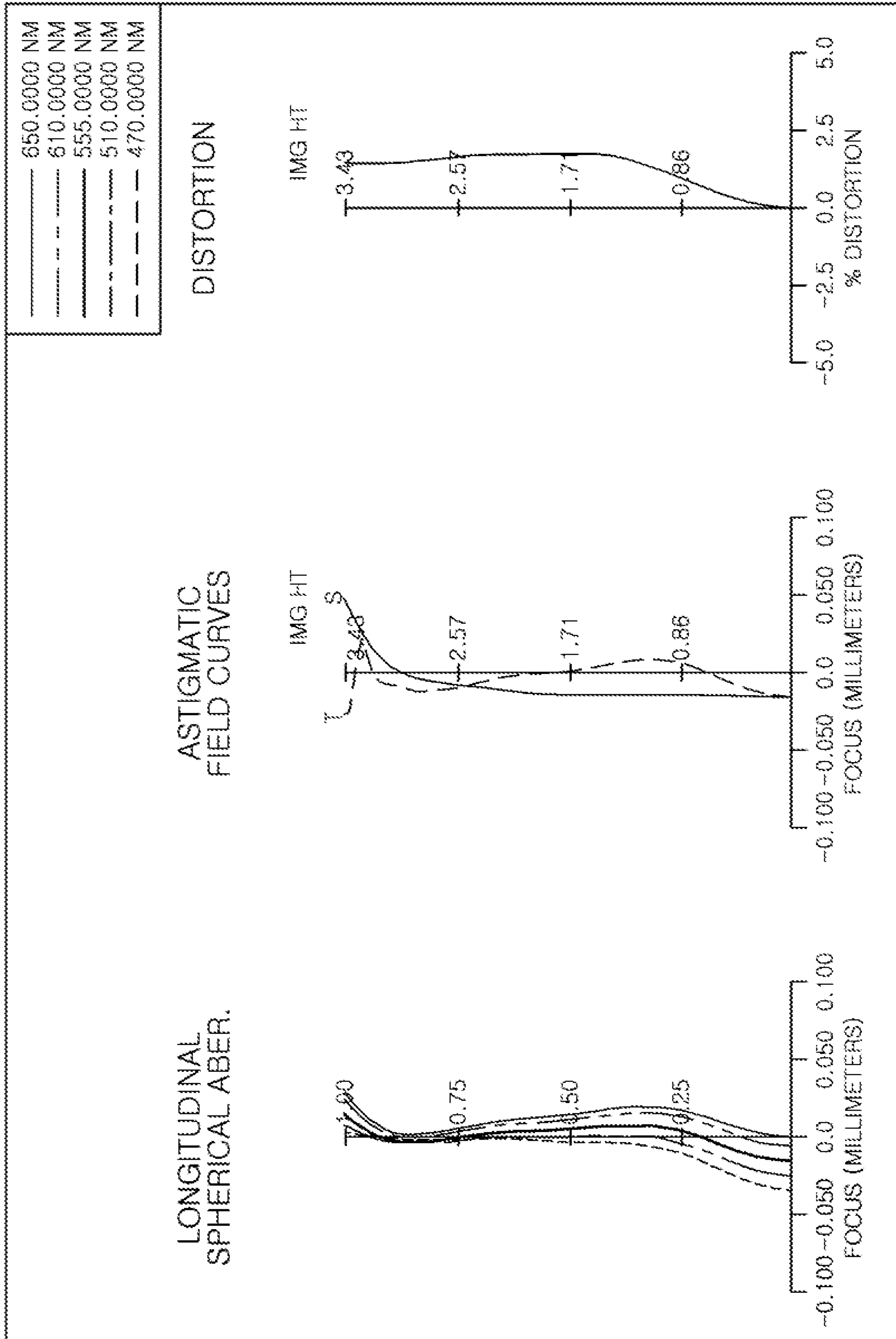

FIG. 36

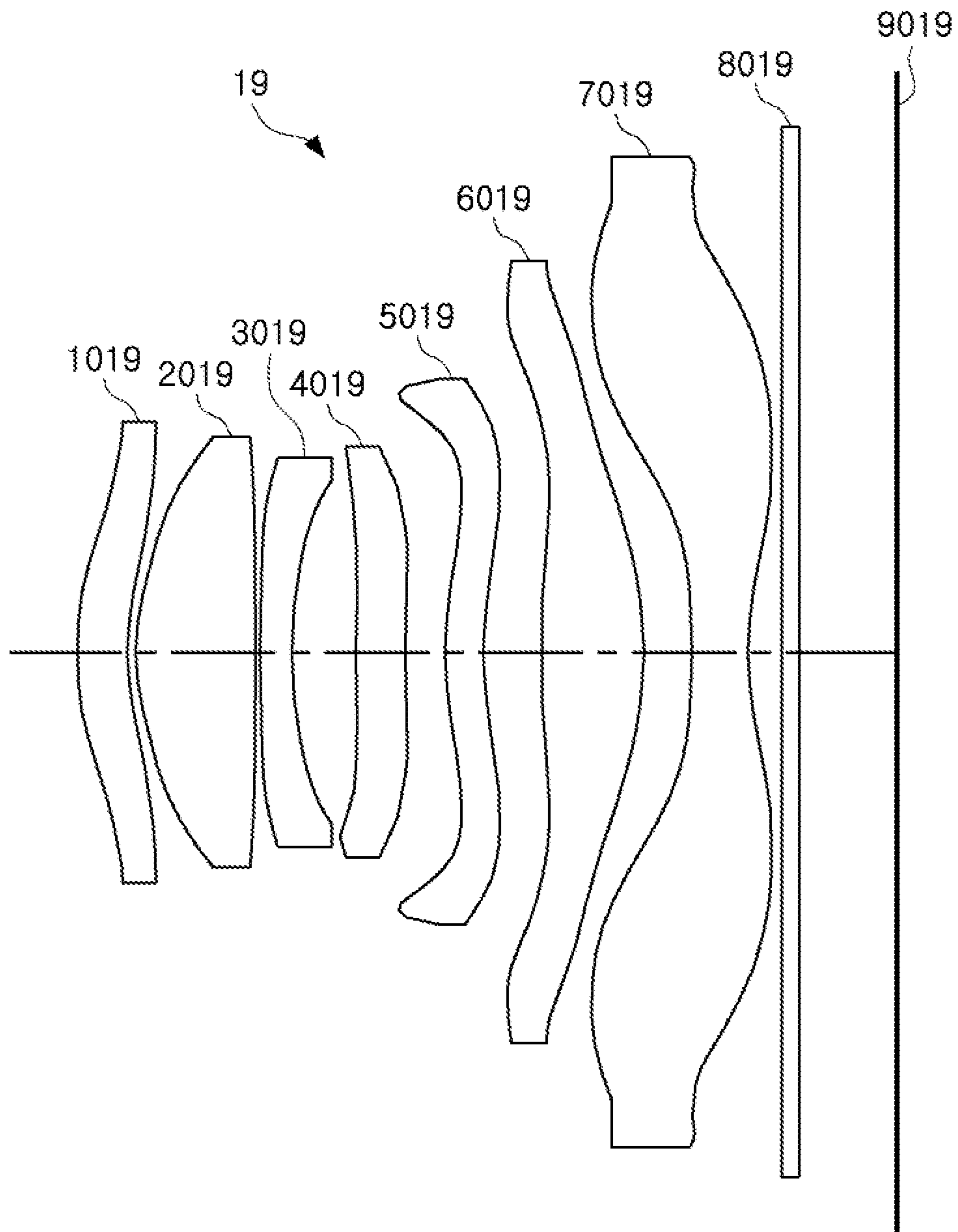

FIG. 37

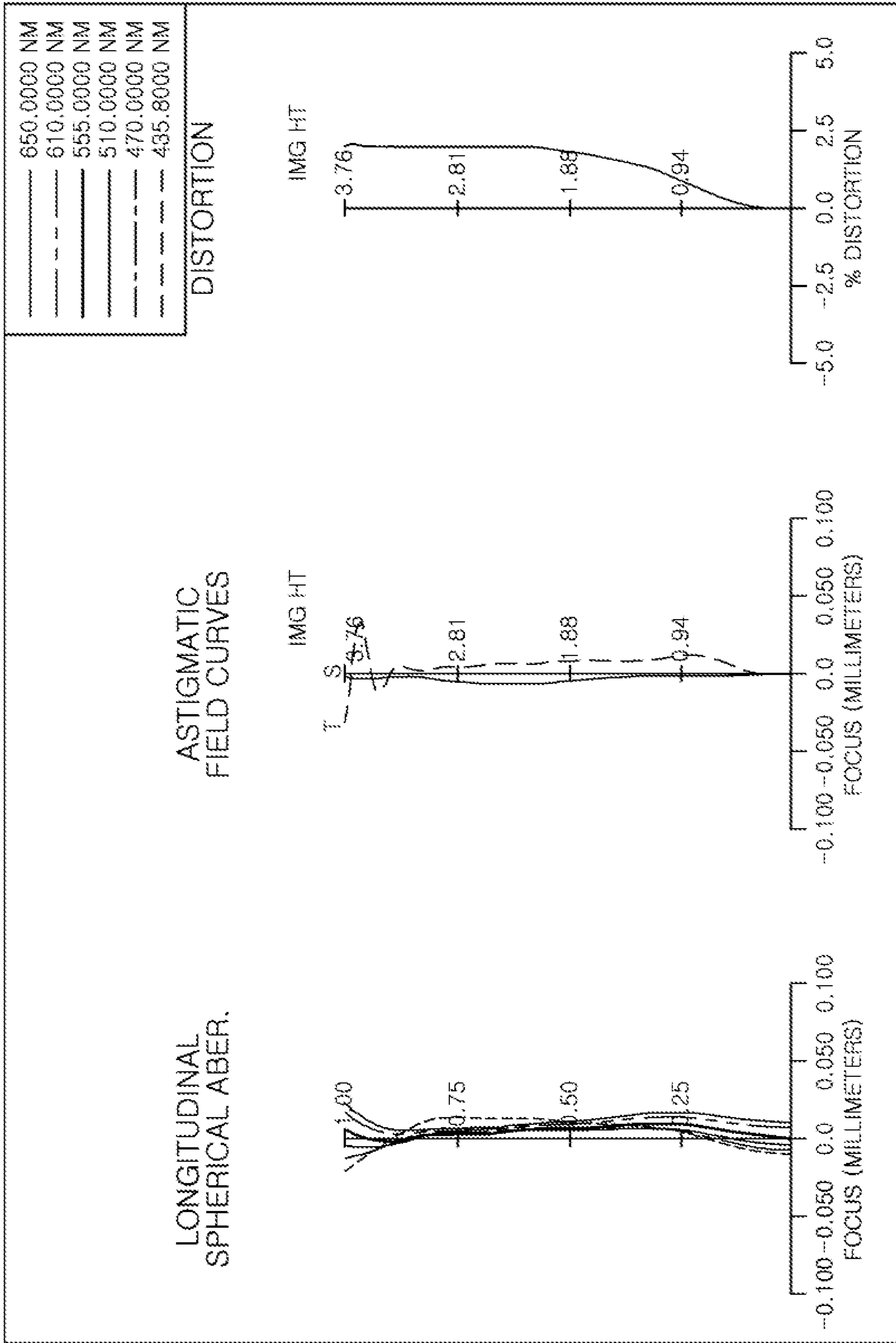

FIG. 38

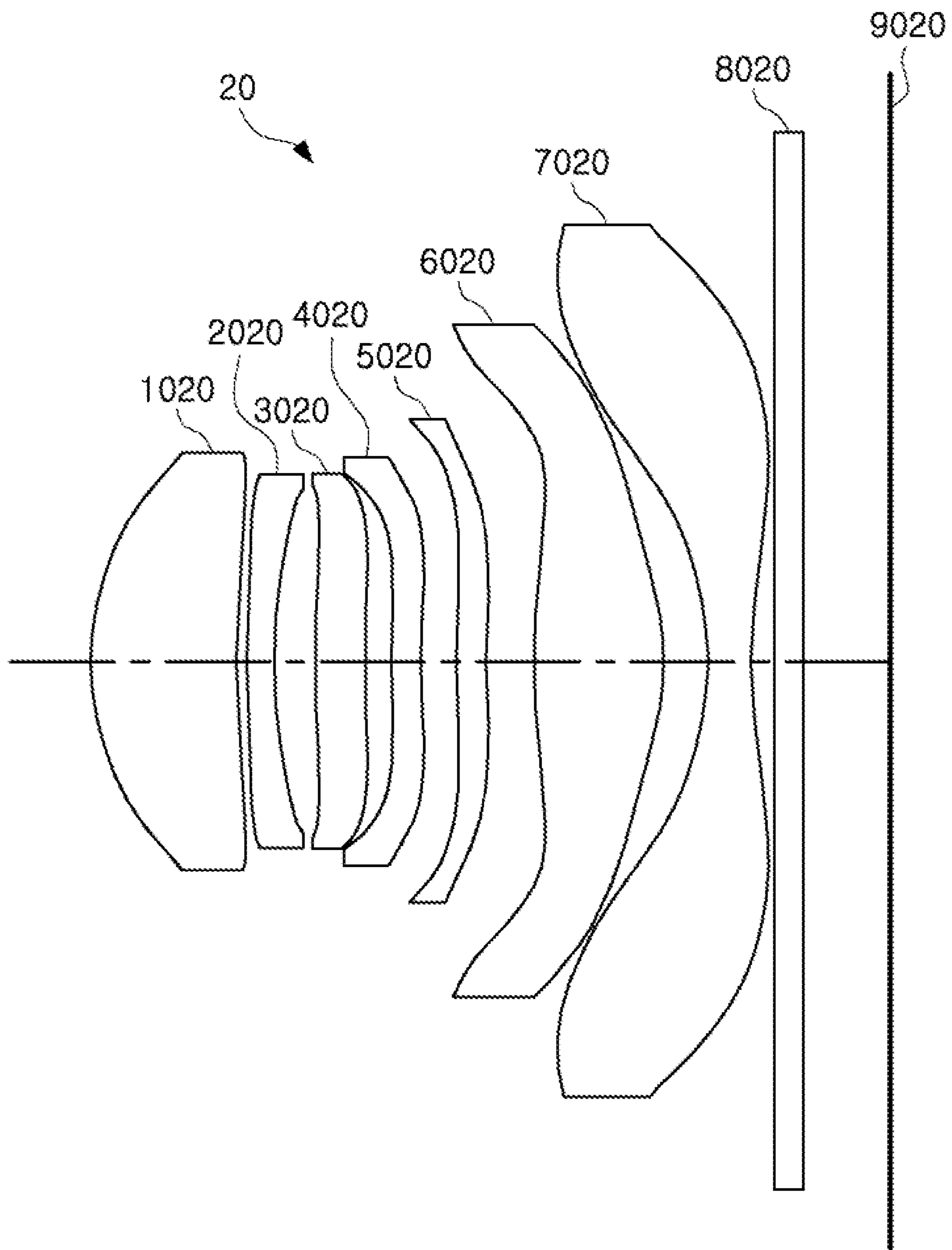

FIG. 39

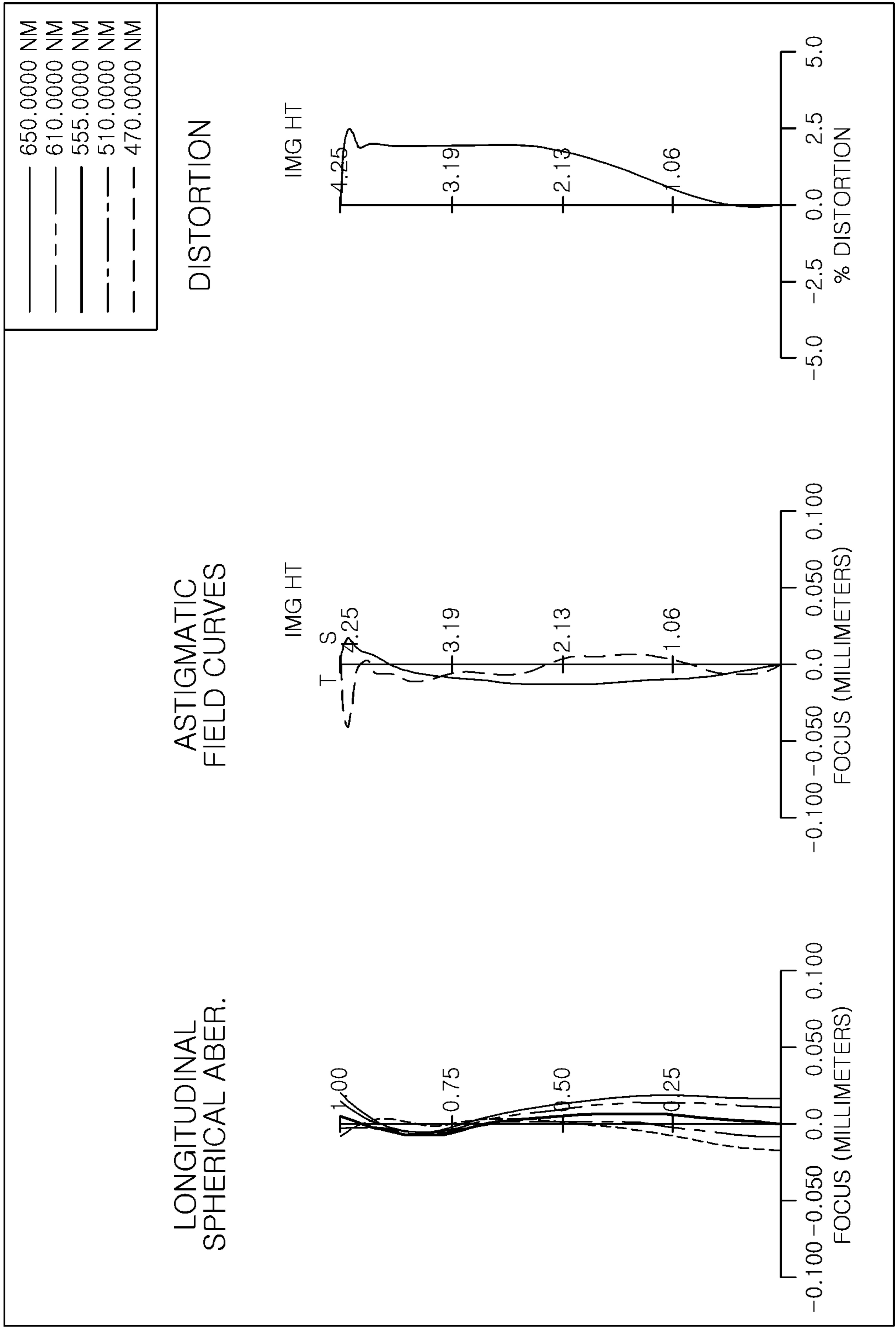

FIG. 40

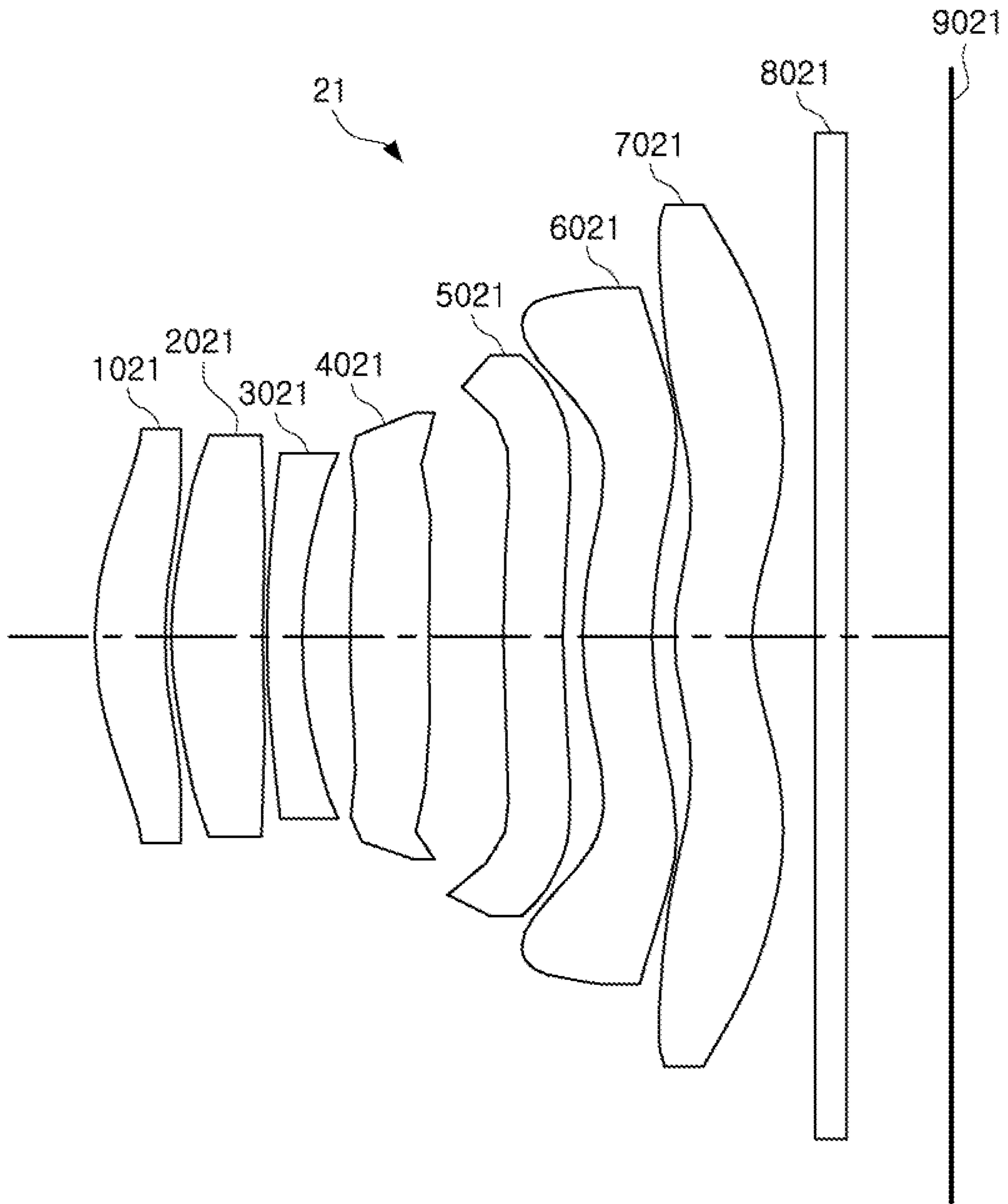

FIG. 41

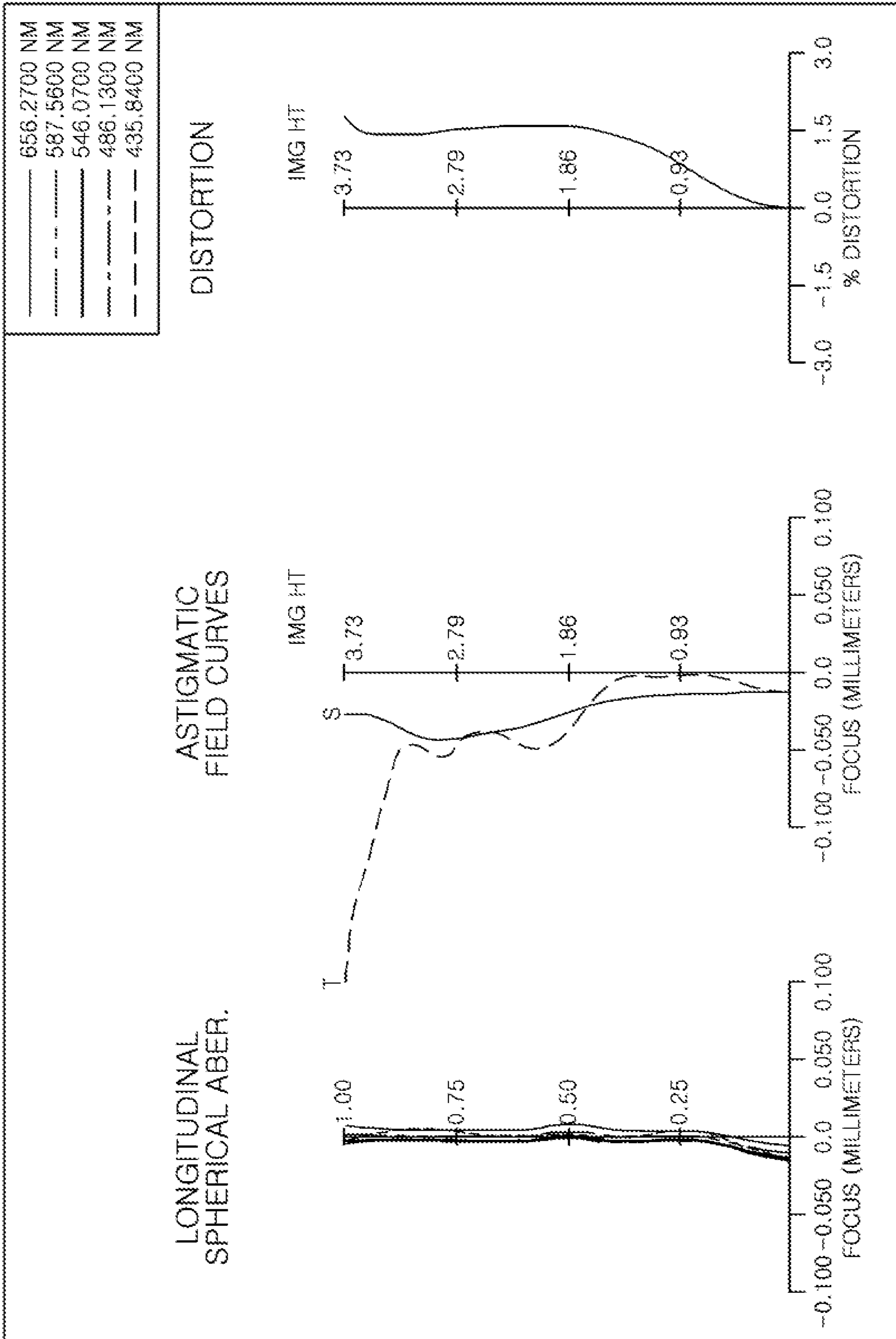

FIG. 42

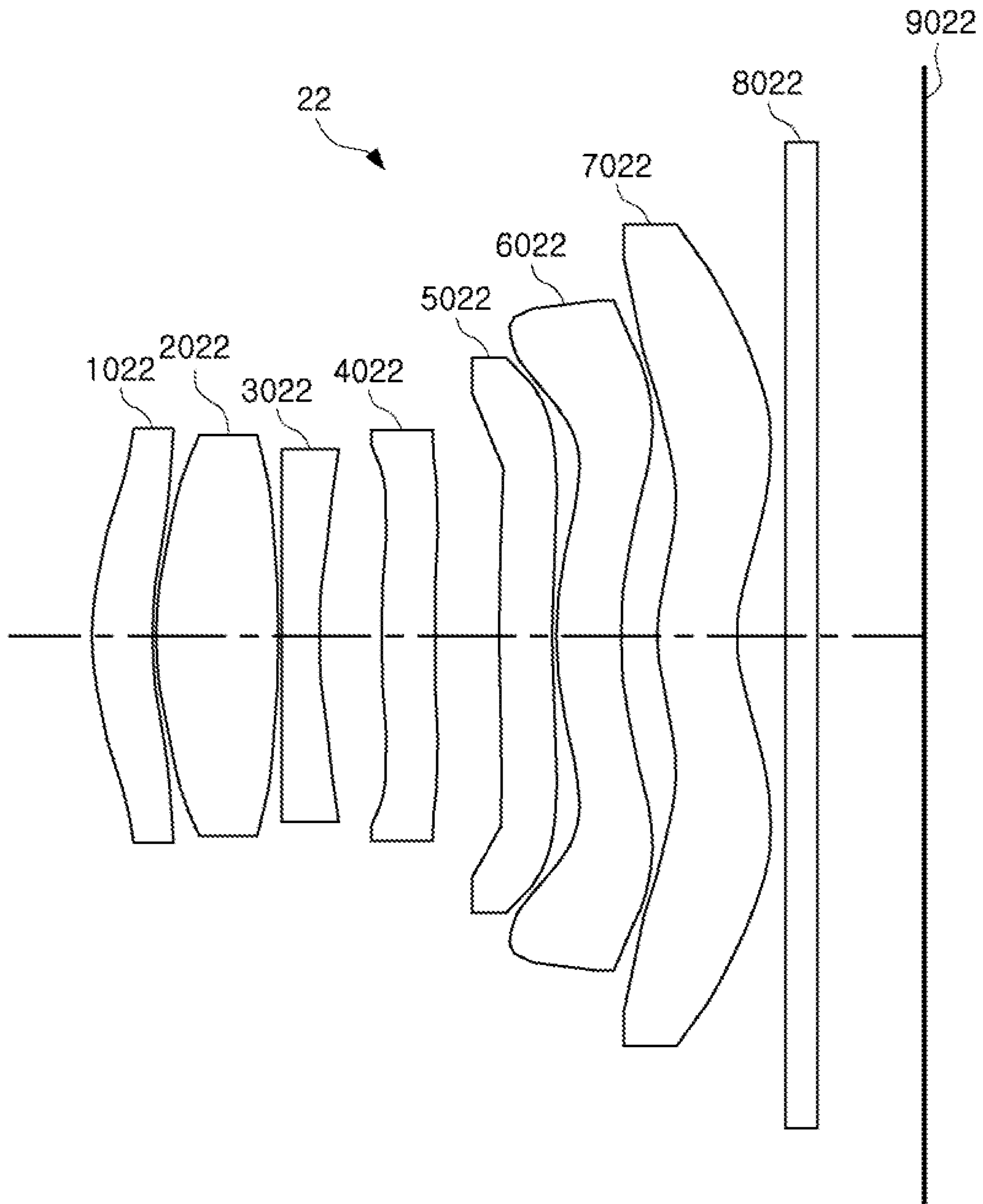

FIG. 43

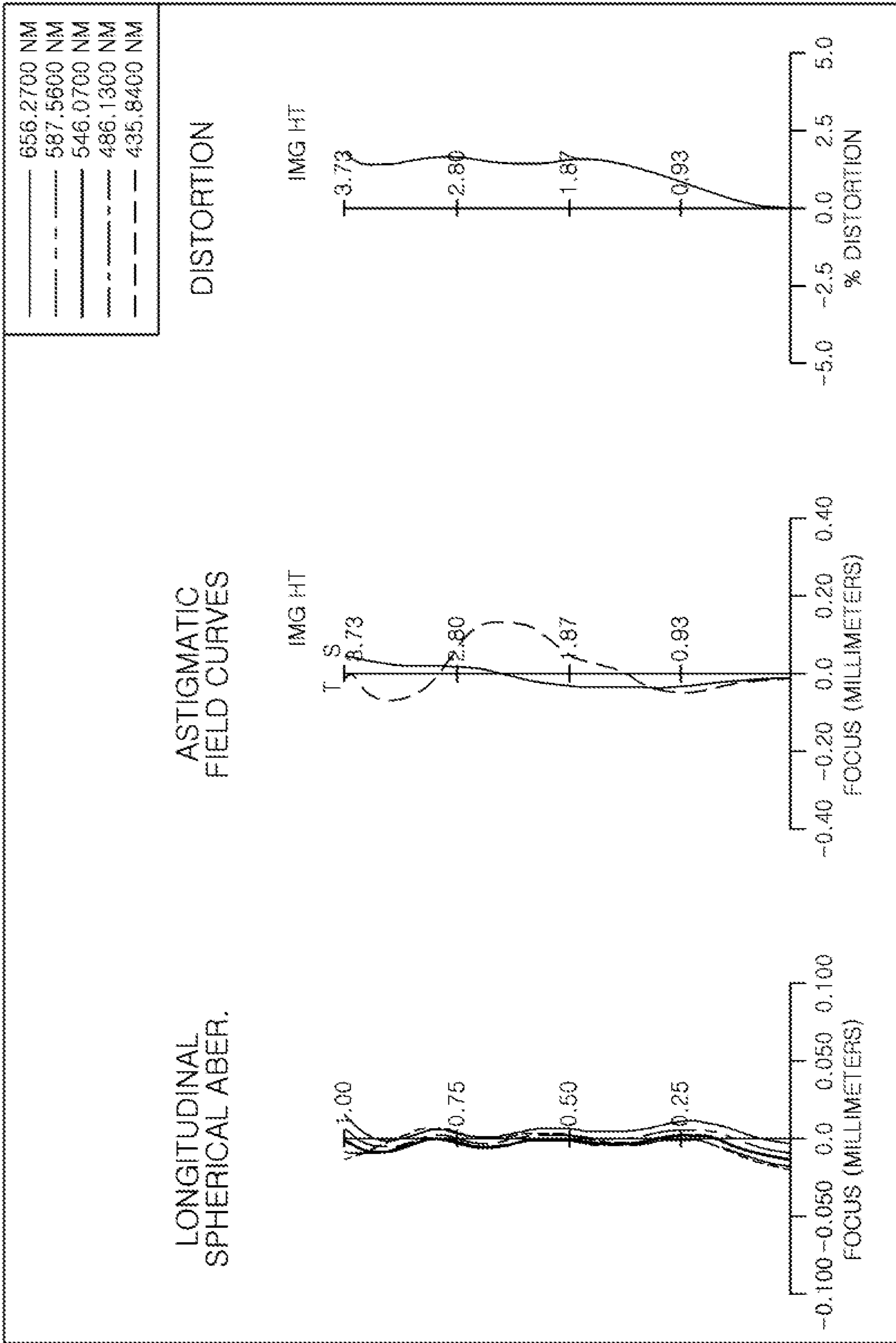

FIG. 44

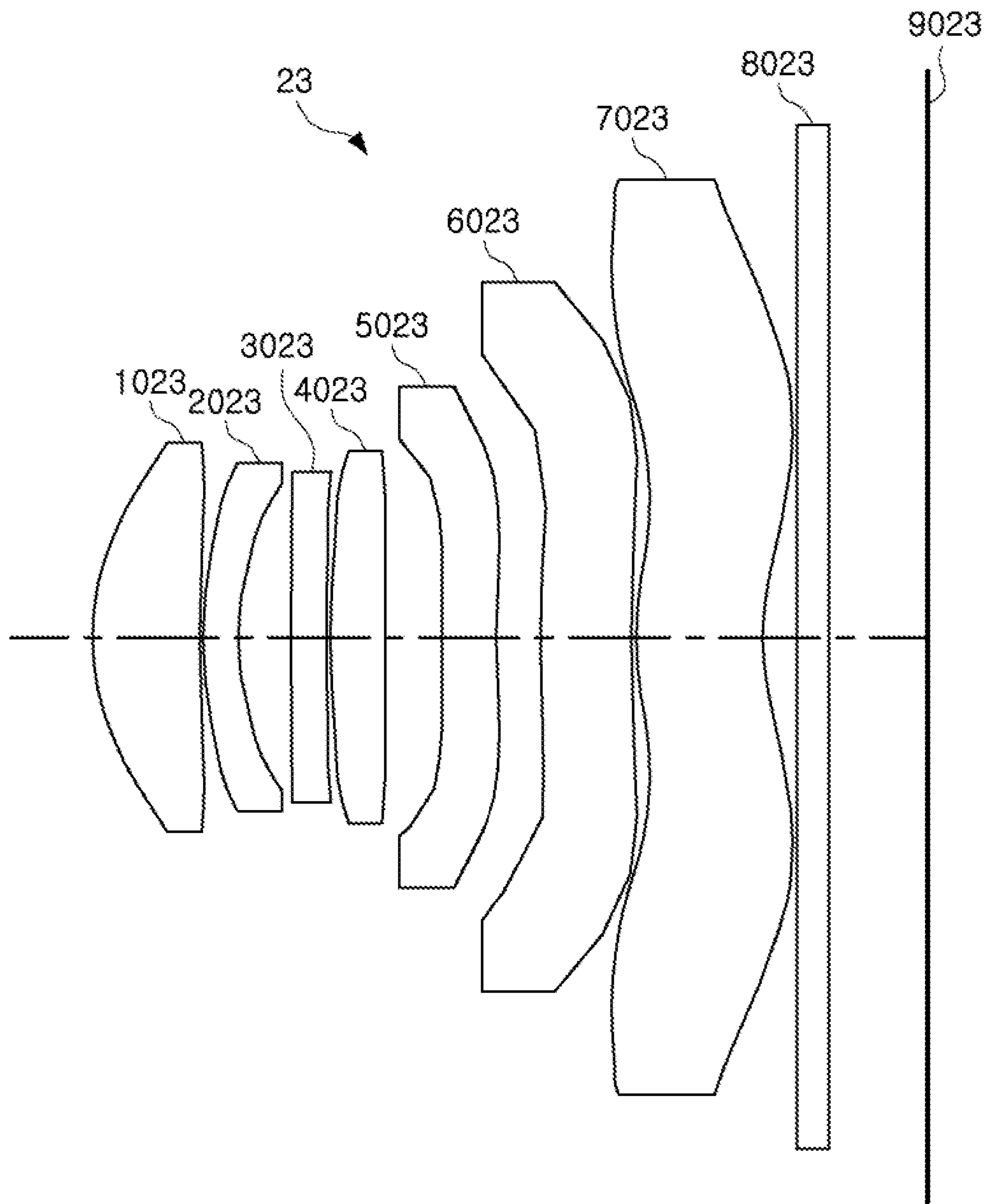

FIG. 45

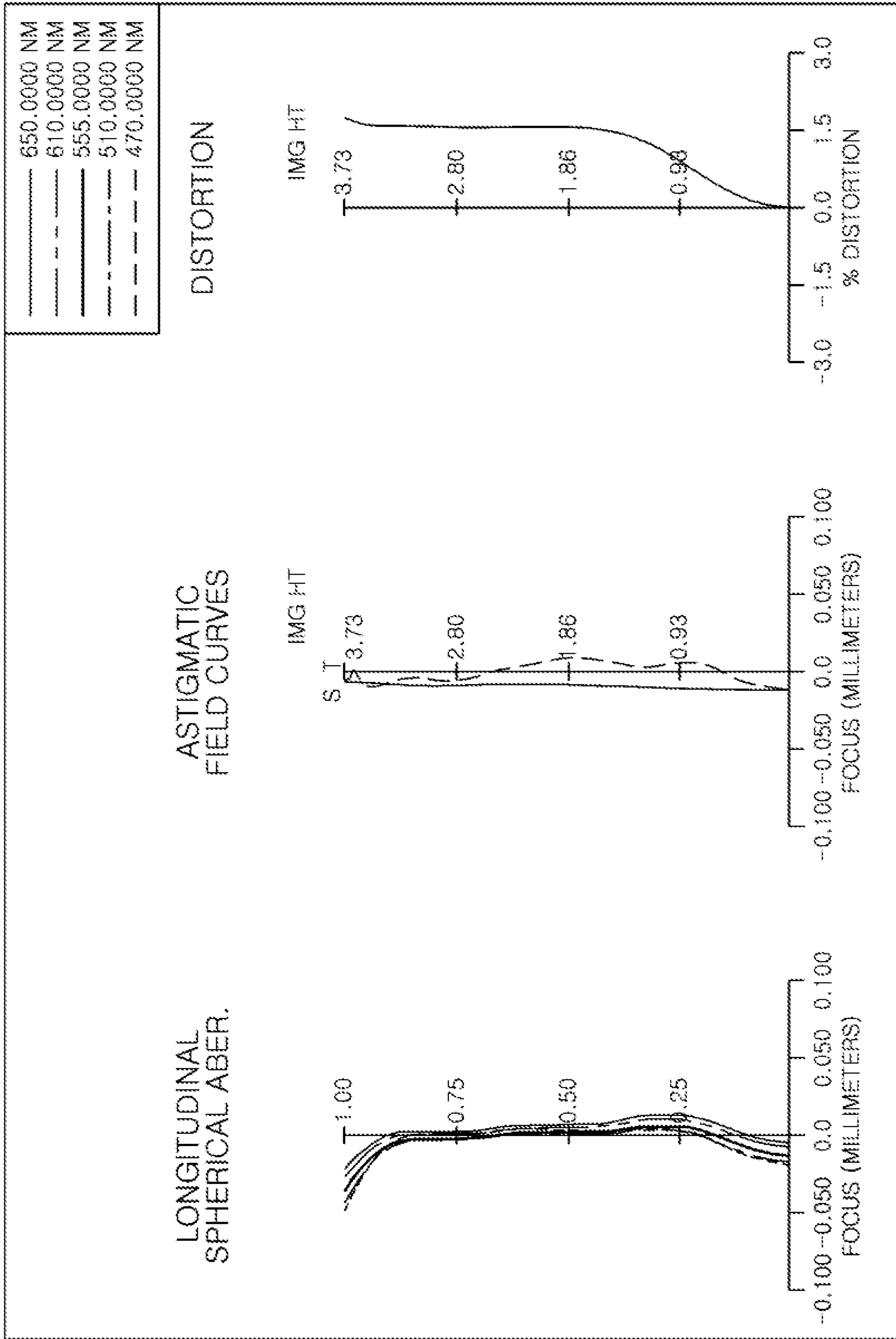

FIG. 46

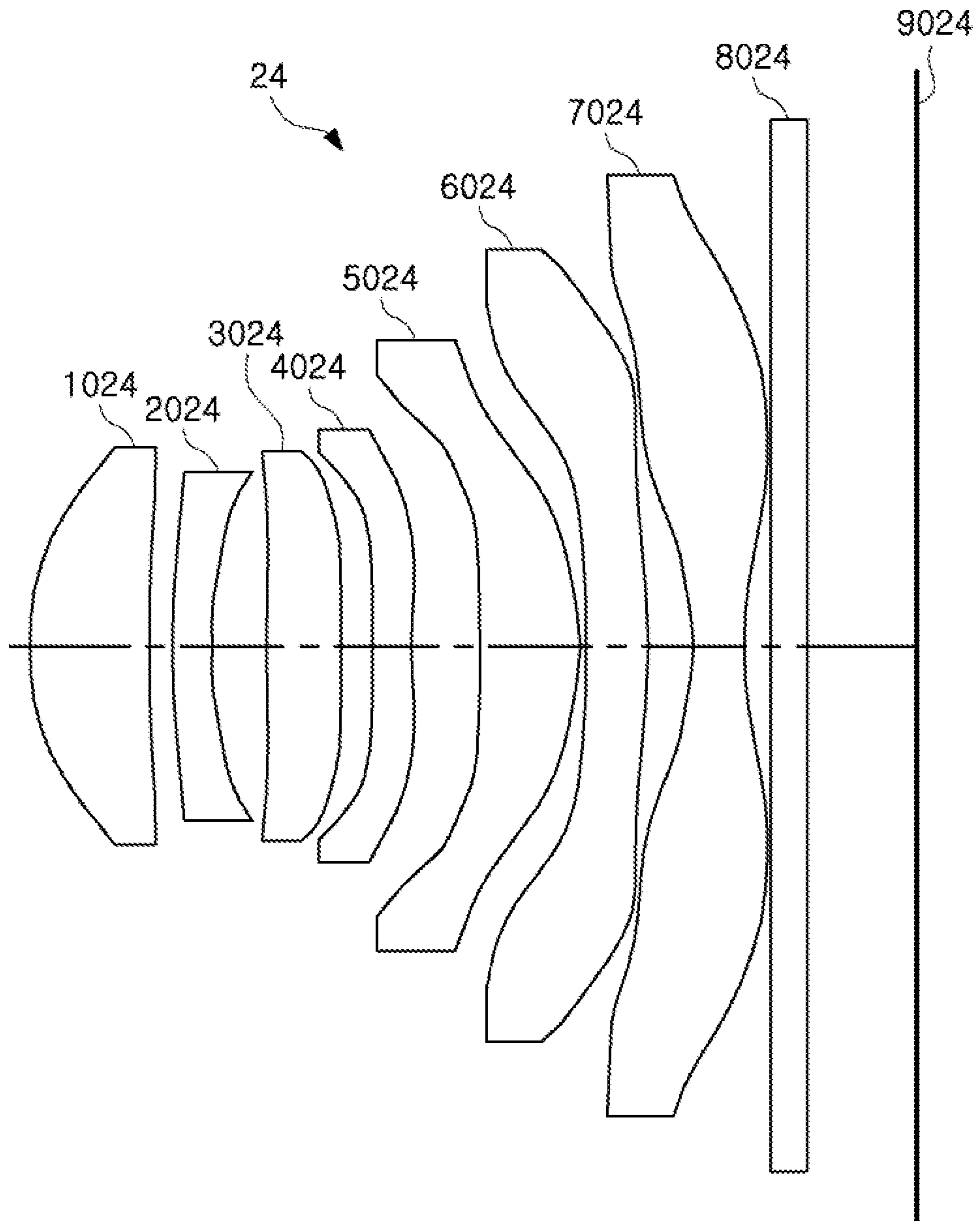

FIG. 47

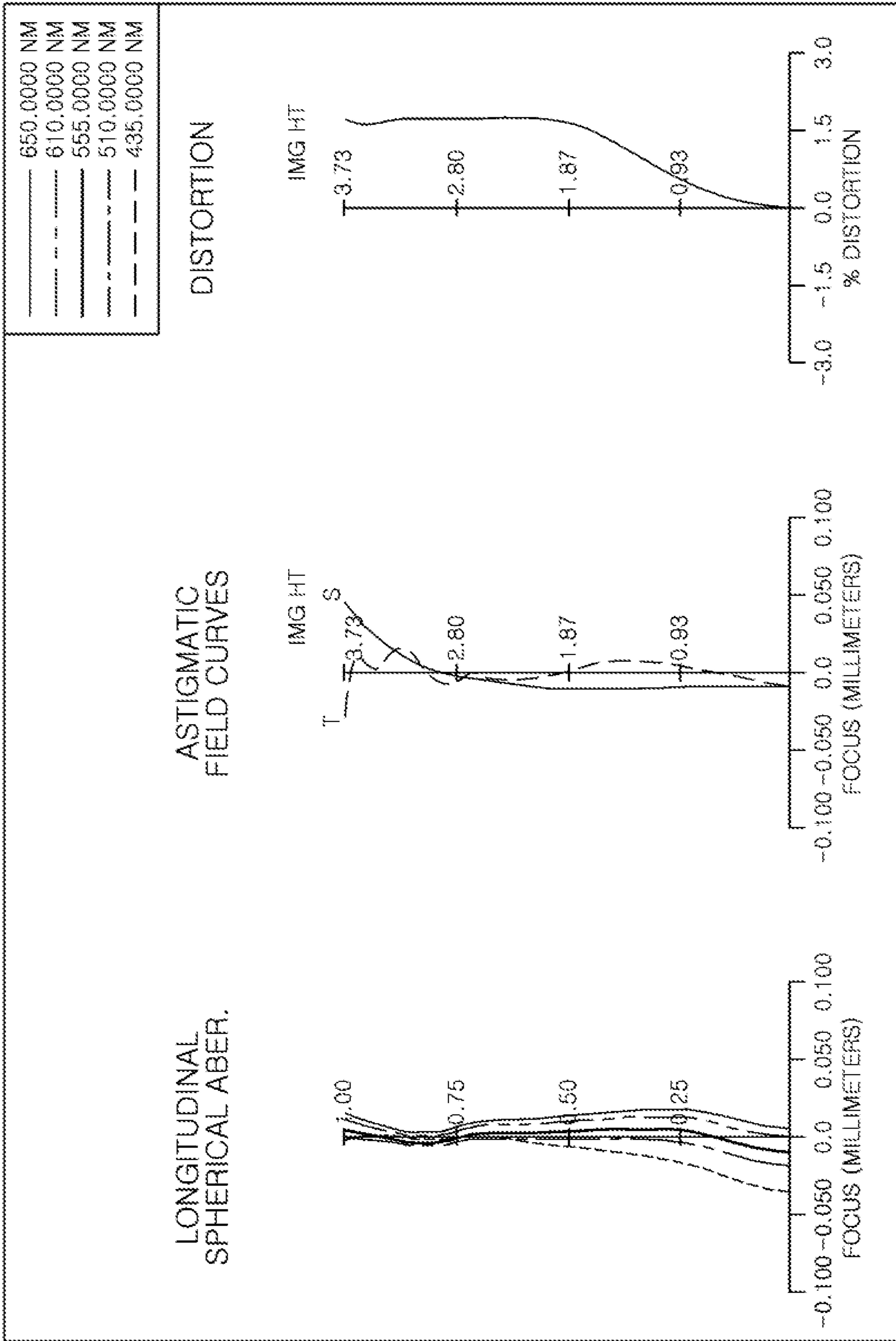

FIG. 48

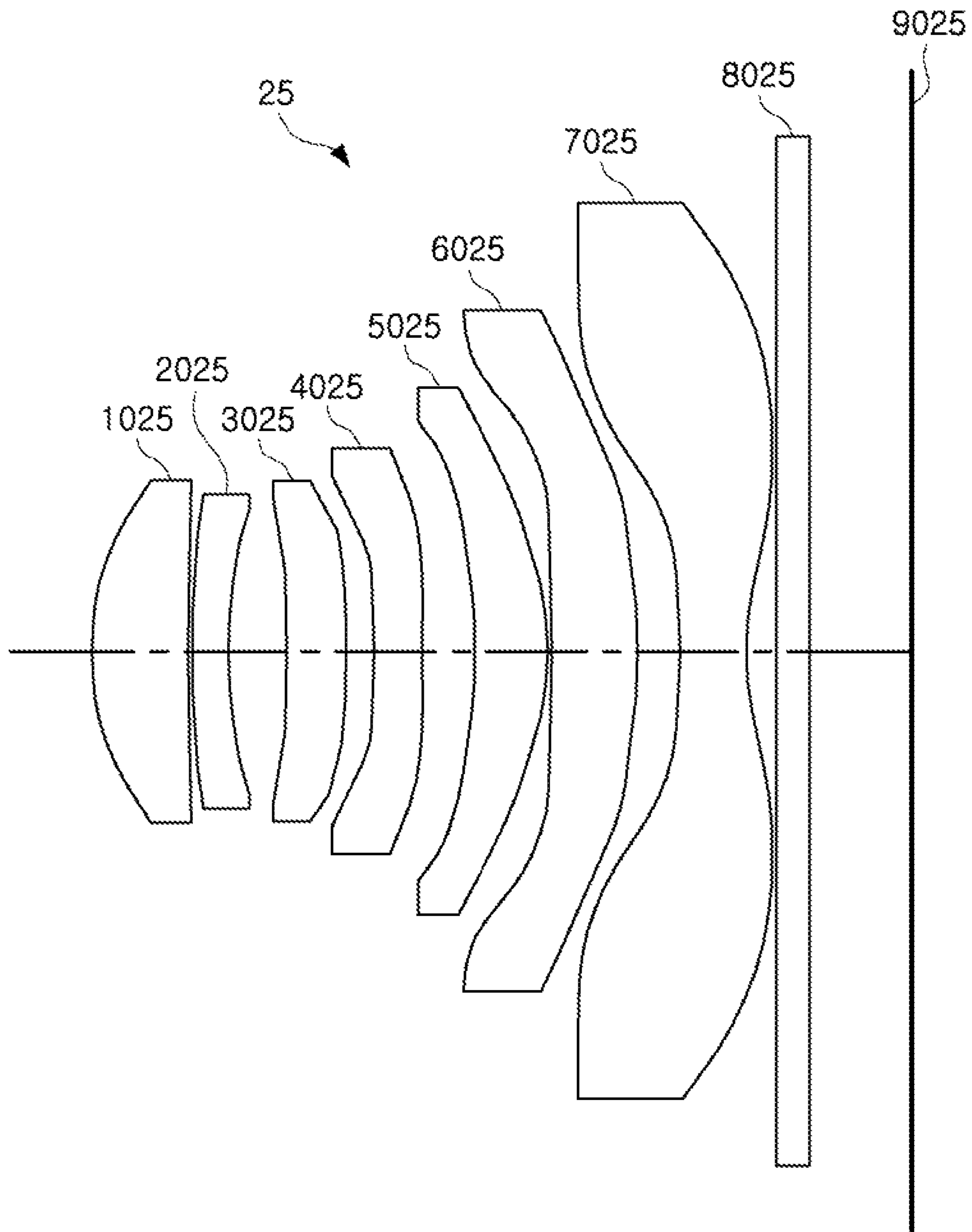

FIG. 49

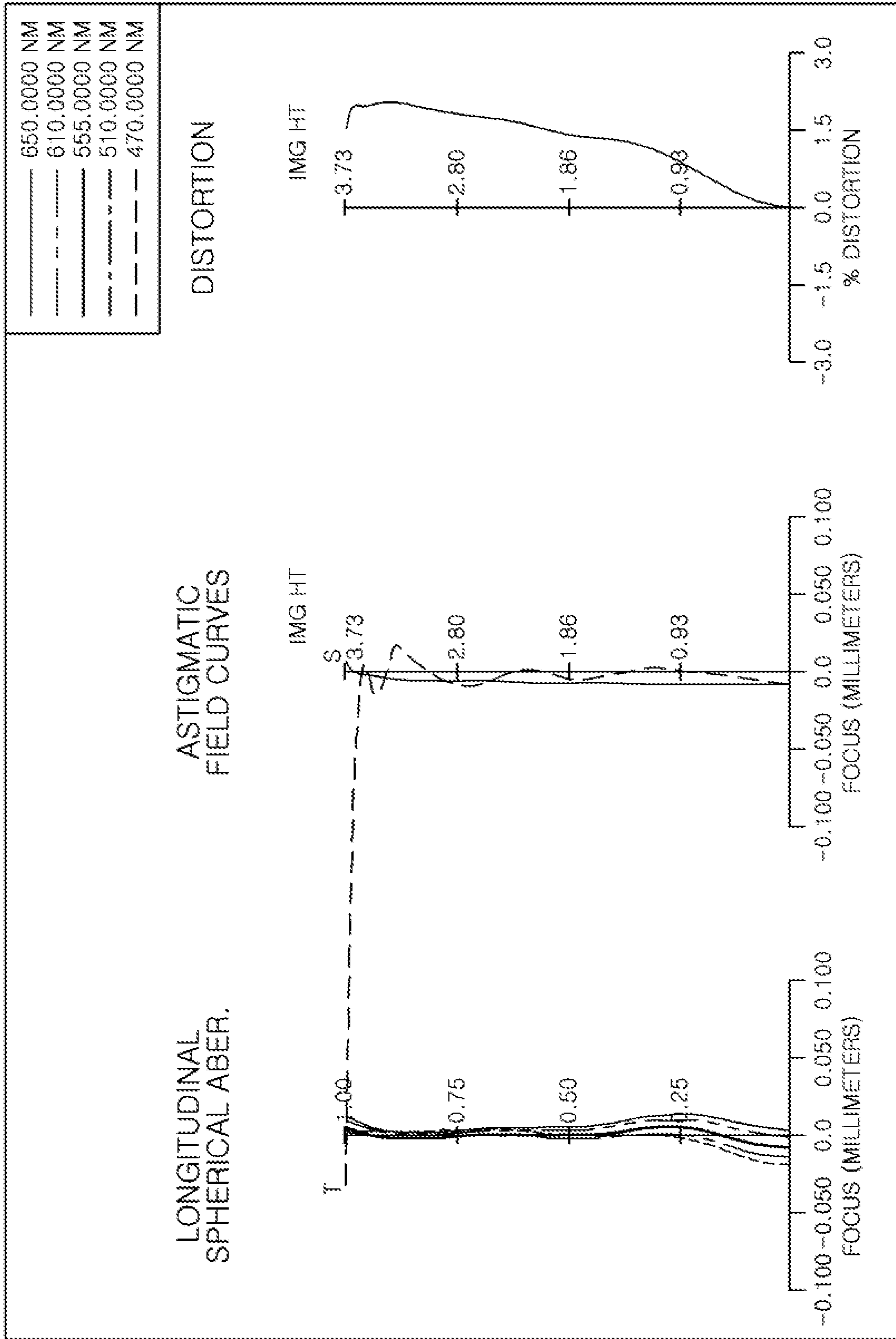

FIG. 50

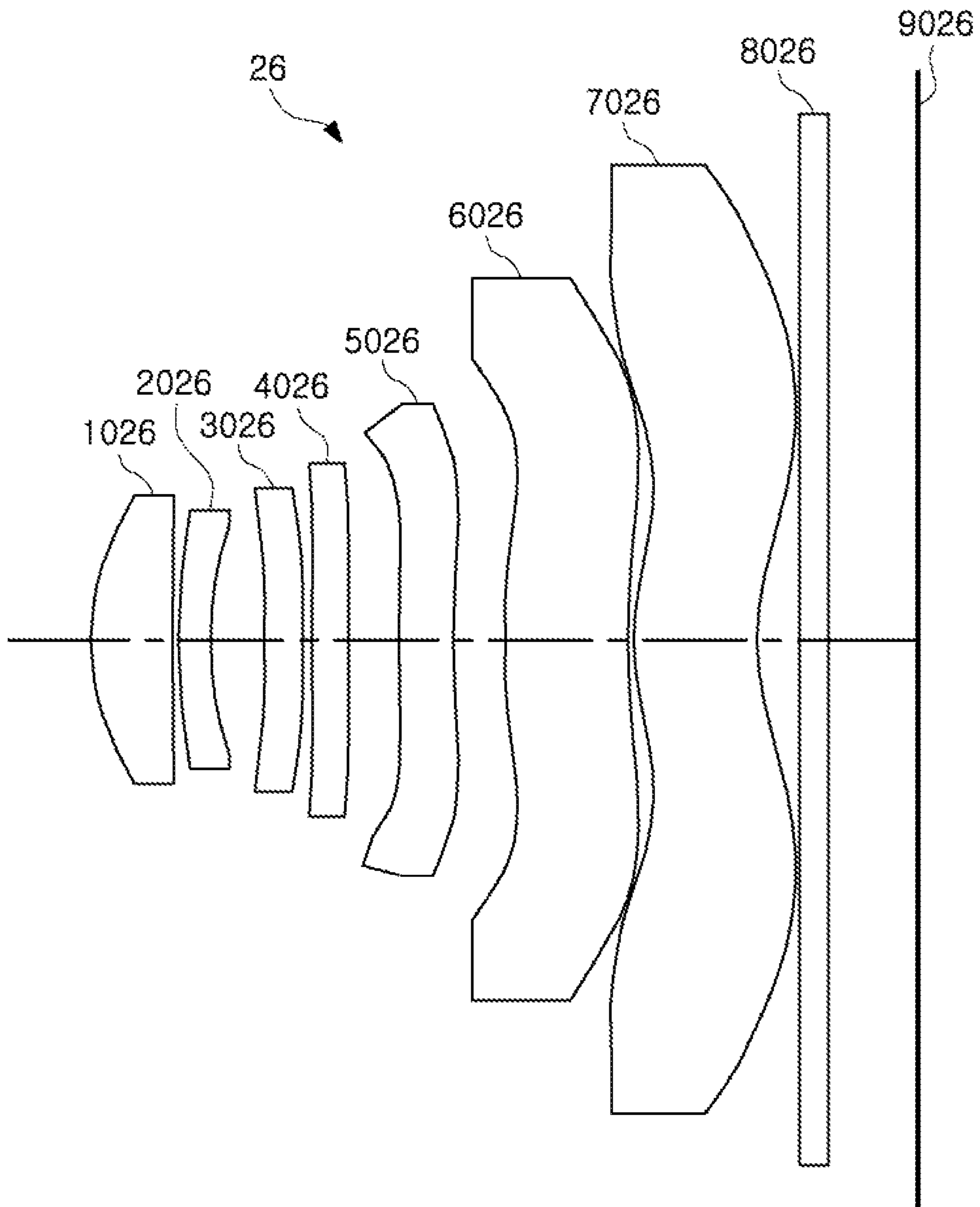

FIG. 51

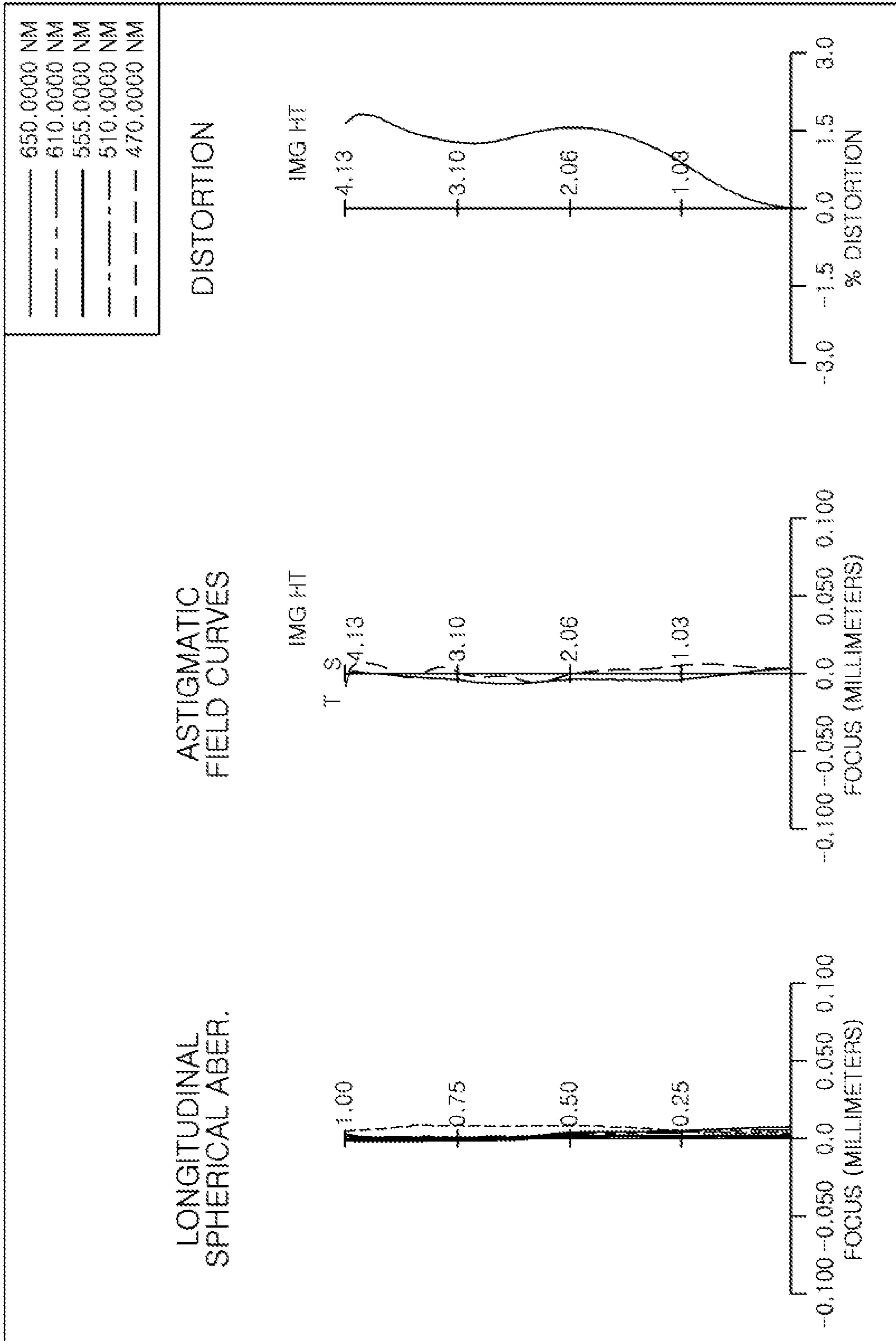

FIG. 52

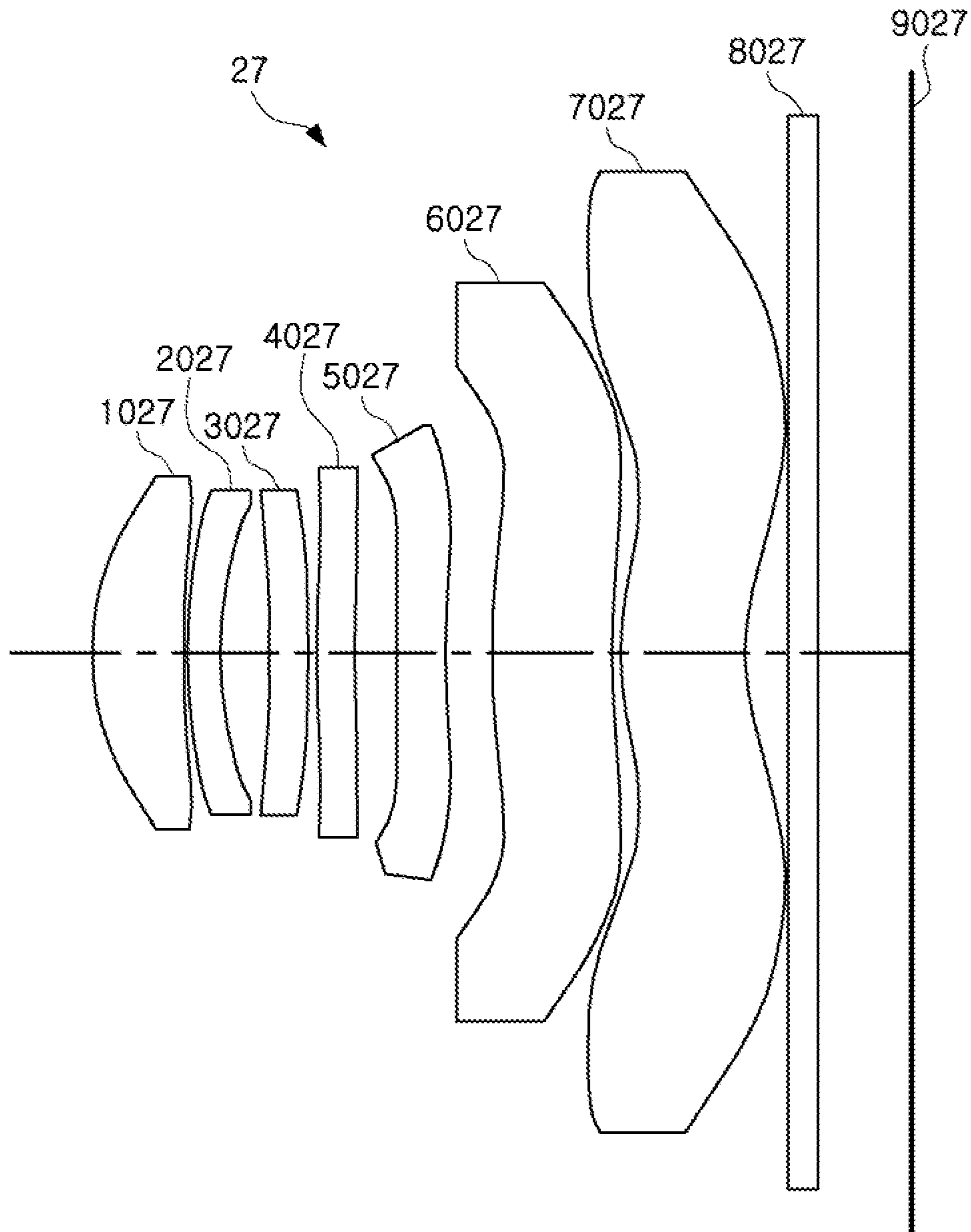

FIG. 53

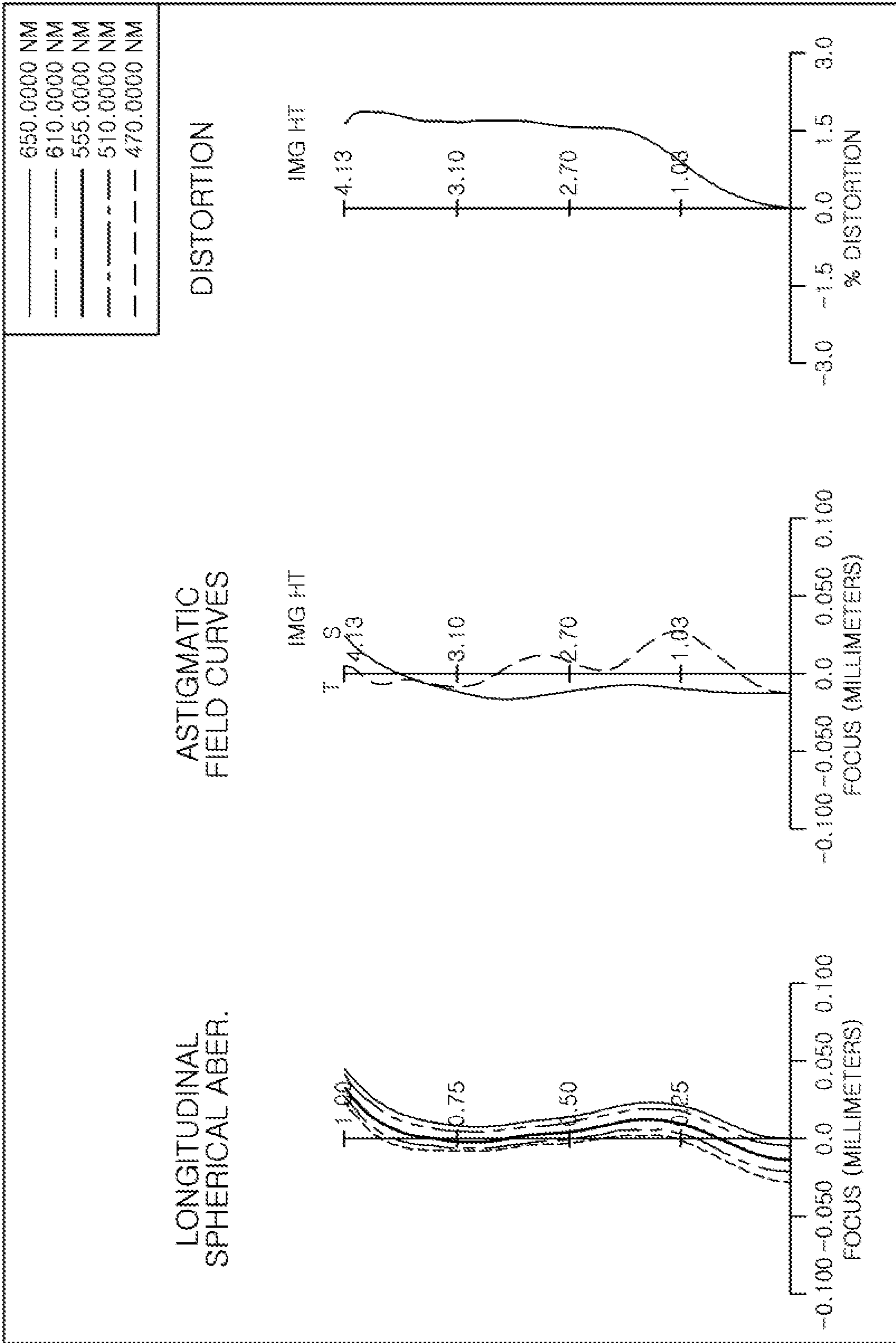

FIG. 54

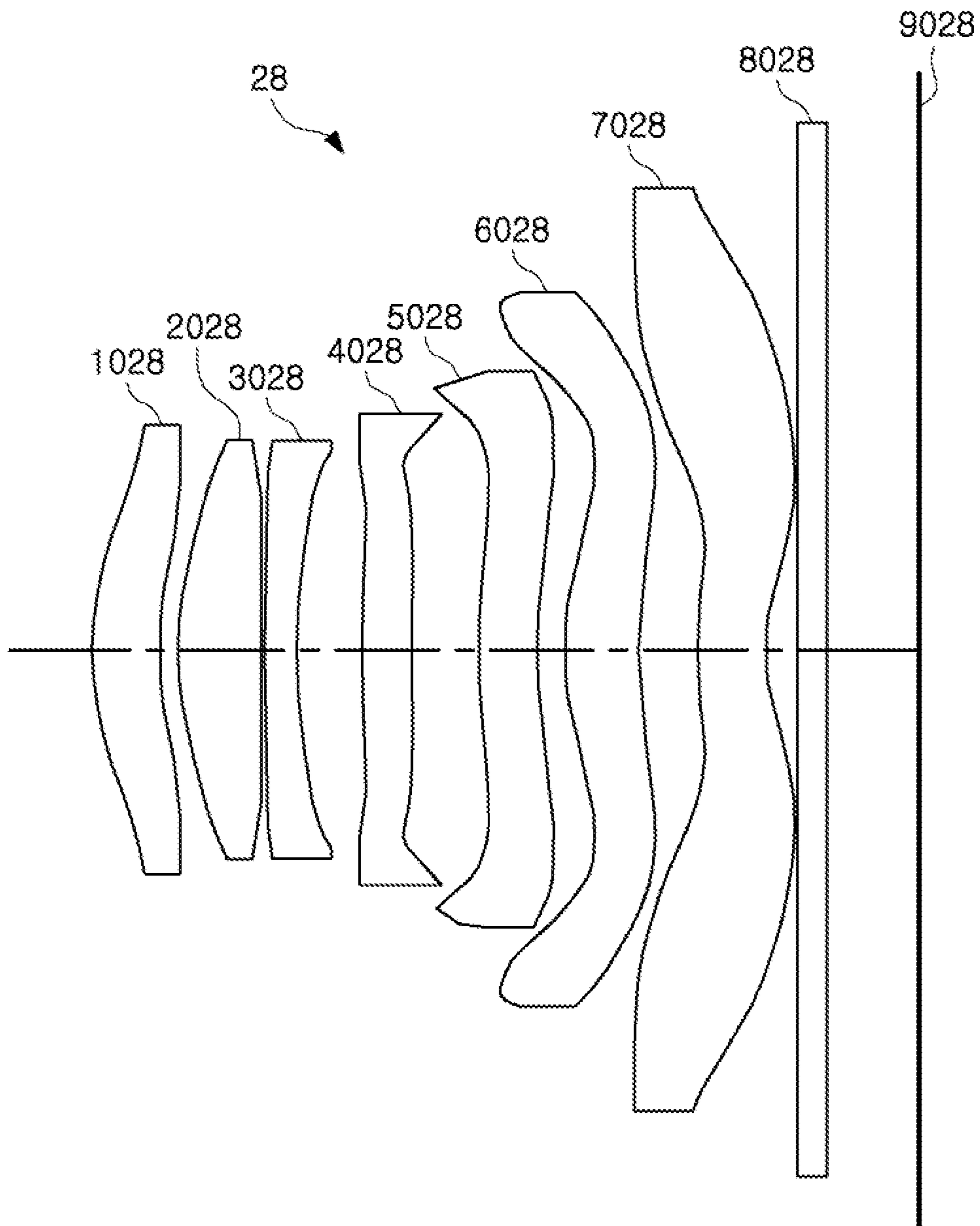

FIG. 55

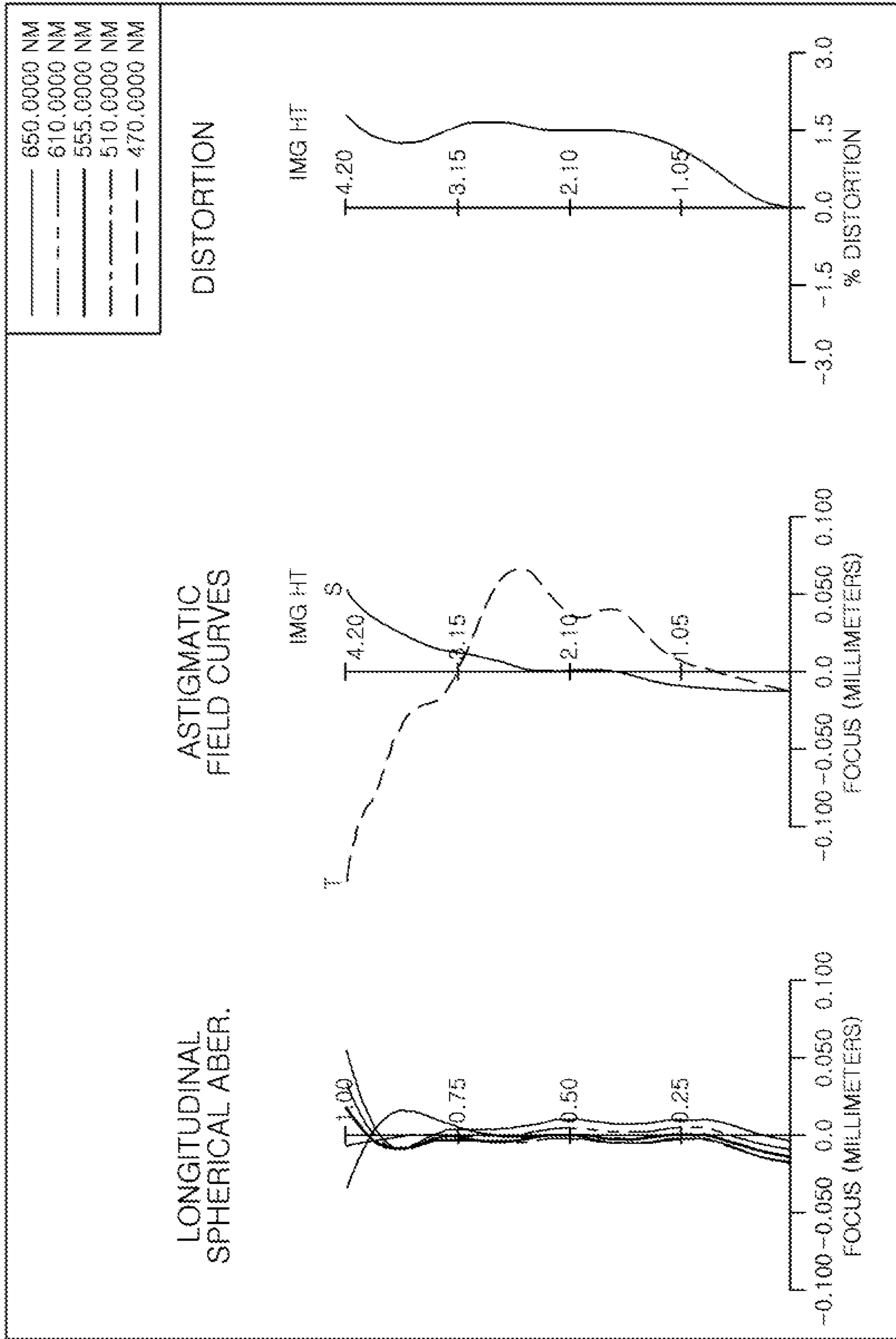

FIG. 56

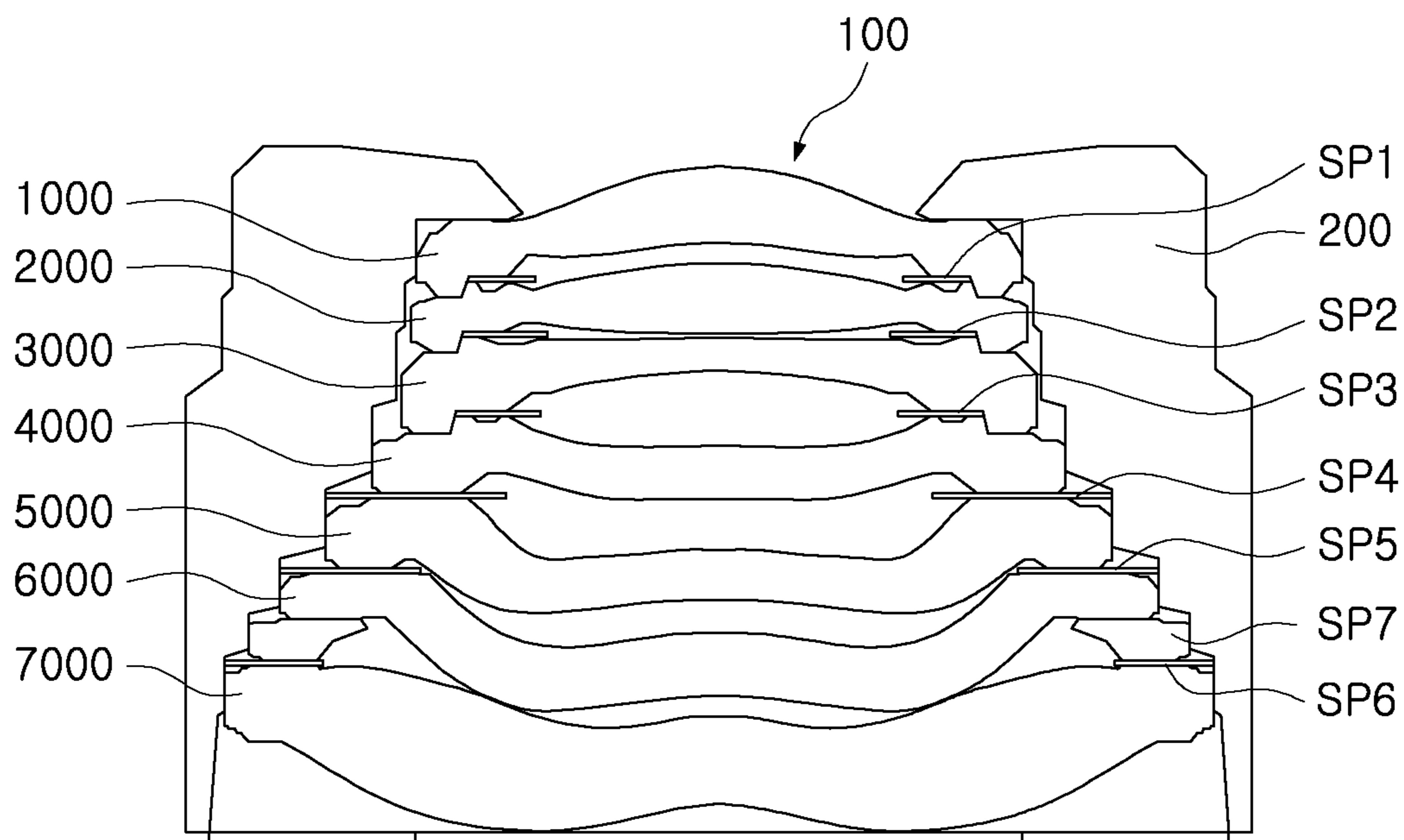

FIG. 57

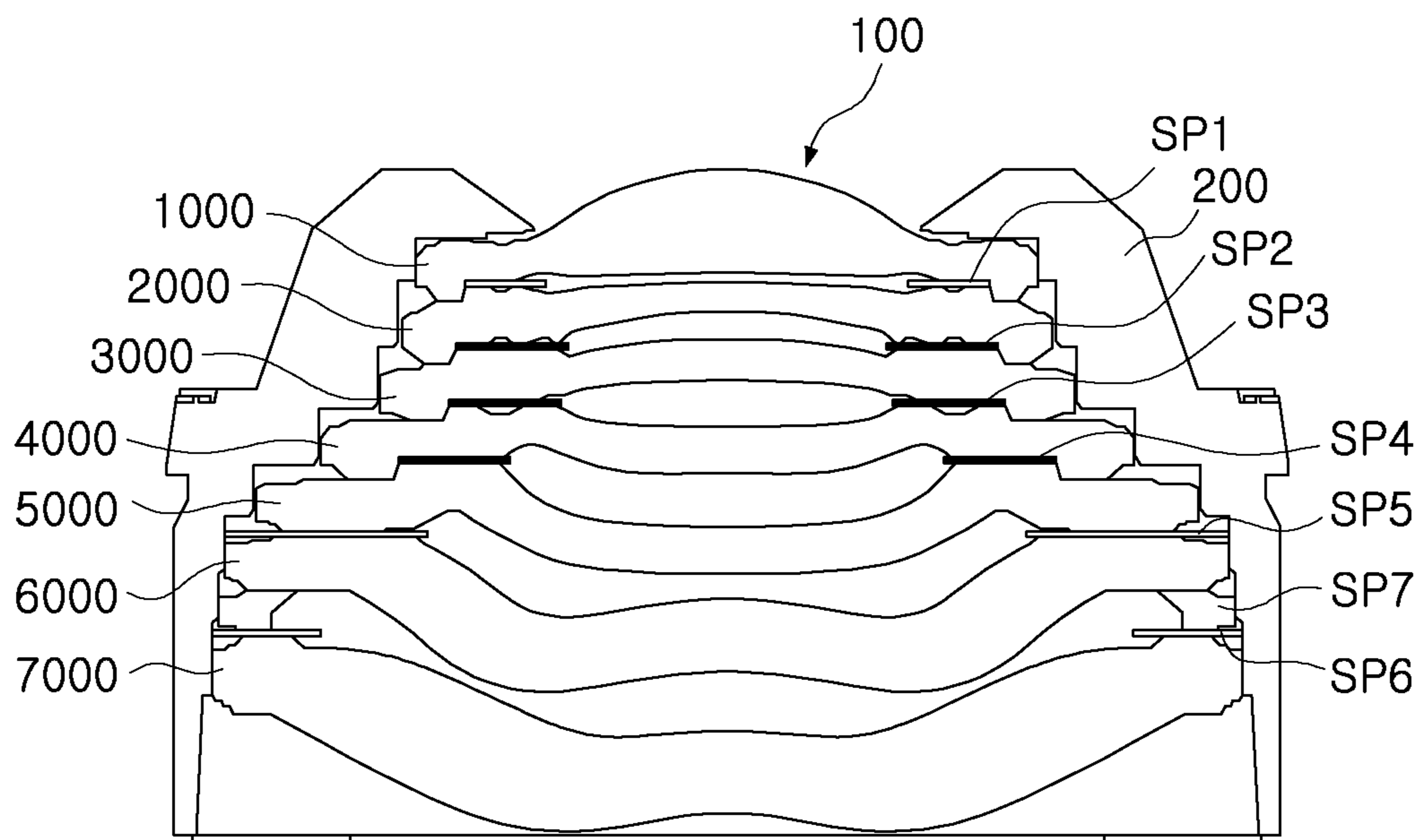

FIG. 58

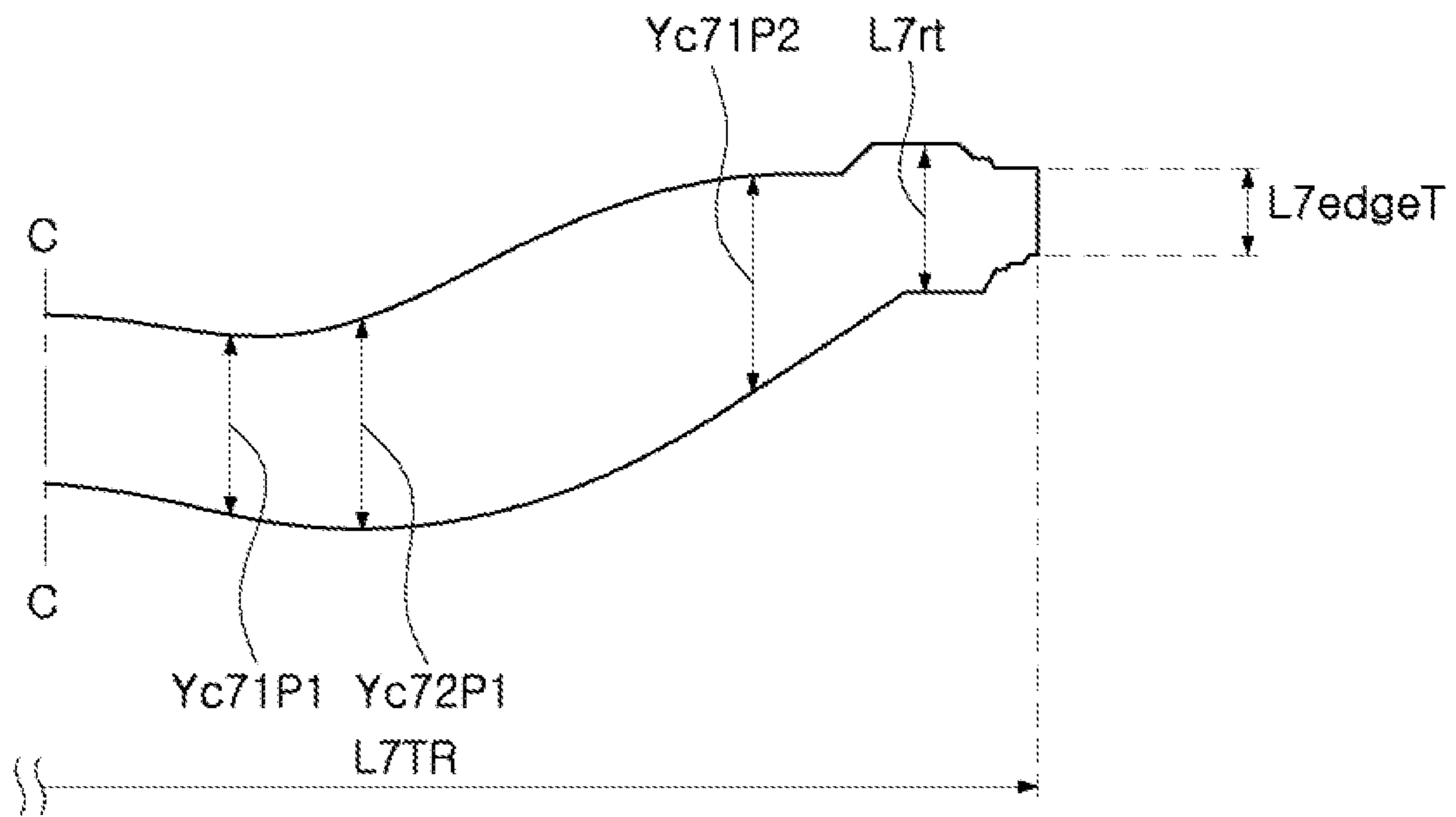

FIG. 59

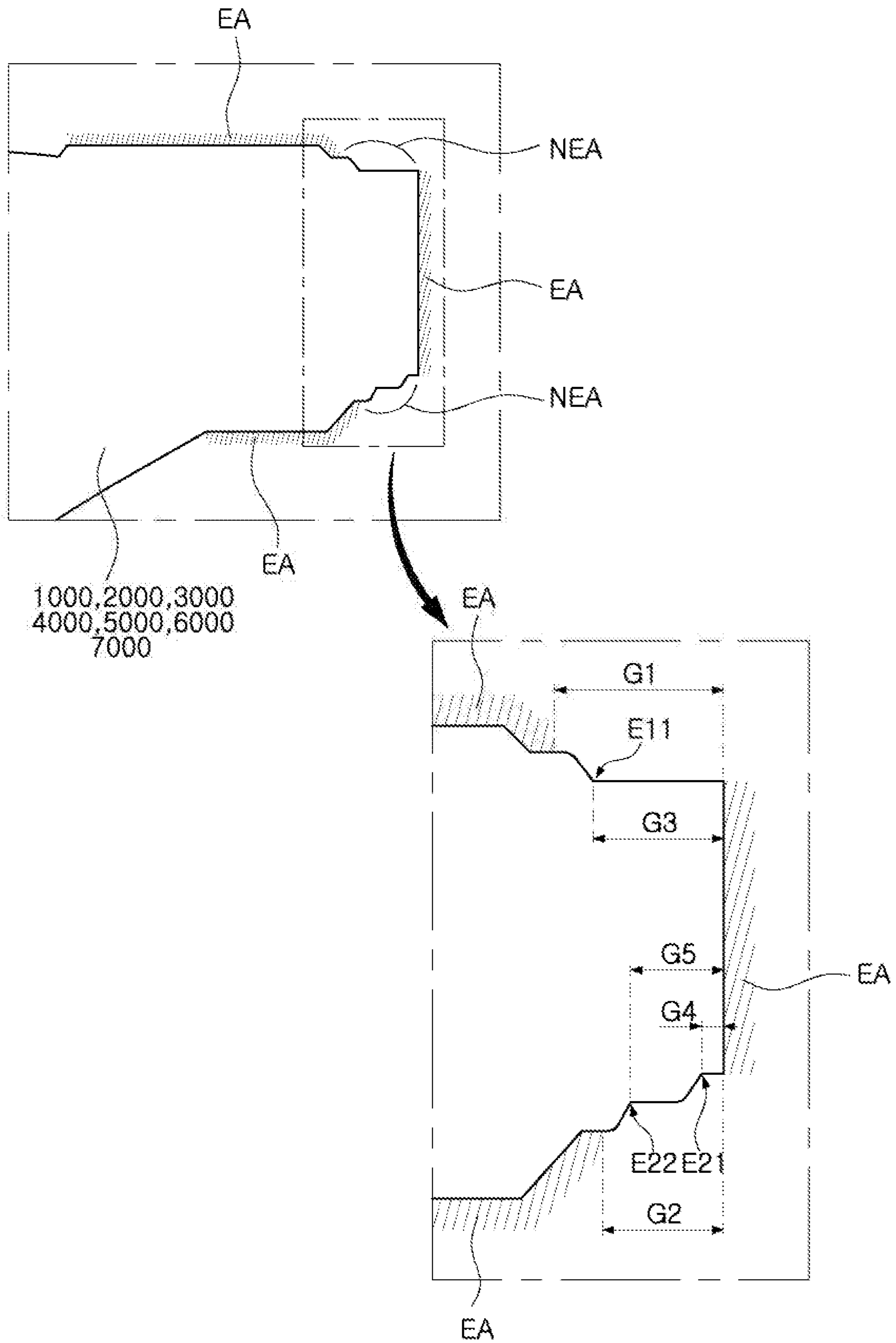

FIG. 60

1

OPTICAL IMAGING SYSTEM

CROSS-REFERENCE TO RELATED APPLICATIONS

This application is a continuation of U.S. patent application Ser. No. 16/424,774 filed on May 29, 2019, now U.S. Pat. No. 11,353,686 issued on Jun. 7, 2022, which claims the benefit under 35 USC 119(a) of Korean Patent Application Nos. 10-2018-0061393 filed on May 29, 2018, and 10-2018-0106185 filed on Sep. 5, 2018, in the Korean Intellectual Property Office, the entire disclosures of which are incorporated herein by reference for all purposes.

BACKGROUND

1. Field

This application relates to an optical imaging system including seven lenses.

2. Description of Related Art

A mobile terminal is commonly provided with a camera for video communications or capturing images. However, it is difficult to achieve high performance in such a camera for a mobile terminal due to space limitations inside the mobile terminal.

Accordingly, a demand for an optical imaging system capable of improving the performance of the camera without increasing a size of the camera has increased as a number of mobile terminals provided with a camera has increased.

SUMMARY

This Summary is provided to introduce a selection of concepts in a simplified form that are further described below in the Detailed Description. This Summary is not intended to identify key features or essential features of the claimed subject matter, nor is it intended to be used as an aid in determining the scope of the claimed subject matter.

In one general aspect, an optical imaging system includes a first lens, a second lens, a third lens, a fourth lens, a fifth lens, a sixth lens, and a seventh lens sequentially disposed in numerical order along an optical axis of the optical imaging system from an object side of the optical imaging system toward an imaging plane of the optical imaging system, wherein the optical imaging system satisfies $1 < f_{134567} - f/f$, where f_{134567} is a composite focal length of the first to seventh lenses calculated with an index of refraction of the second lens set to 1.0, f is an overall focal length of the optical imaging system, and f_{134567} and f are expressed in a same unit of measurement.

An object-side surface of the first lens may be convex.

An image-side surface of the seventh lens may be concave.

At least one inflection point may be formed on either one or both of an object-side surface and an image-side surface of the sixth lens.

At least one inflection point may be formed on either one or both of an object-side surface and an image-side surface of the seventh lens.

A distance along the optical axis from an object-side surface of the first lens to the imaging plane may be 6.0 mm or less.

An F No. of the optical imaging system may be less than 1.7.

2

An object-side surface of the second lens may be convex.

An image-side surface of the third lens may be concave.

An object-side surface or an image-side surface of the fourth lens may be concave.

5 An image-side surface of the fifth lens may be concave.

Either one or both of an object-side surface and an image-side surface of the sixth lens may be convex.

10 The optical imaging system may further satisfy $0.1 < L1w/L7w < 0.3$, where $L1w$ is a weight of the first lens, $L7w$ is a weight of the seventh lens, and $L1w$ and $L7w$ are expressed in a same unit of measurement.

15 The optical imaging system may further include a spacer disposed between the sixth and seventh lenses, and the optical imaging system may further satisfy $0.5 < S6d/f < 1.2$, where $S6d$ is an inner diameter of the spacer, f is the overall focal length of the optical imaging system, and $S6d$ and f are expressed in a same unit of measurement.

20 The optical imaging system may further satisfy $0.4 < L1TR/L7TR < 0.7$, where $L1TR$ is an overall outer diameter of the first lens, $L7TR$ is an overall outer diameter of the seventh lens, and $L1TR$ and $L7TR$ are expressed in a same unit of measurement.

25 The optical imaging system may further satisfy $0.5 < L_{1234TRavg}/L7TR < 0.75$, where $L_{1234TRavg}$ is an average value of overall outer diameters of the first to fourth lenses, $L7TR$ is an overall diameter of the seventh lens, and $L_{1234TRavg}$ and $L7TR$ are expressed in a same unit of measurement.

30 The optical imaging system may further satisfy $0.5 < L_{12345TRavg}/L7TR < 0.76$, where $L_{12345TRavg}$ is an average value of overall outer diameters of the first to fifth lenses, $L7TR$ is an overall outer diameter of the seventh lens, and $L_{12345TRavg}$ and $L7TR$ are expressed in a same unit of measurement.

35 The second lens may have a positive refractive power.

The third lens may have a positive refractive power.

A paraxial region of an object-side surface of the seventh lens may be concave.

40 Other features and aspects will be apparent from the following detailed description, the drawings, and the claims.

BRIEF DESCRIPTION OF DRAWINGS

45 FIG. 1 is a view illustrating a first example of an optical imaging system.

FIG. 2 illustrates aberration curves of the optical imaging system of FIG. 1.

FIG. 3 is a view illustrating a second example of an optical imaging system.

50 FIG. 4 illustrates aberration curves of the optical imaging system of FIG. 3.

FIG. 5 is a view illustrating a third example of an optical imaging system.

55 FIG. 6 illustrates aberration curves of the optical imaging system of FIG. 5.

FIG. 7 is a view illustrating a fourth example of an optical imaging system.

FIG. 8 illustrates aberration curves of the optical imaging system of FIG. 7.

60 FIG. 9 is a view illustrating a fifth example of an optical imaging system.

FIG. 10 illustrates aberration curves of the optical imaging system of FIG. 9.

65 FIG. 11 is a view illustrating a sixth example of an optical imaging system.

FIG. 12 illustrates aberration curves of the optical imaging system of FIG. 11.

3

FIG. 13 is a view illustrating a seventh example of an optical imaging system.

FIG. 14 illustrates aberration curves of the optical imaging system of FIG. 13.

FIG. 15 is a view illustrating an eighth example of an optical imaging system.

FIG. 16 illustrates aberration curves of the optical imaging system of FIG. 15.

FIG. 17 is a view illustrating a ninth example of an optical imaging system.

FIG. 18 illustrates aberration curves of the optical imaging system of FIG. 17.

FIG. 19 is a view illustrating a tenth example of an optical imaging system.

FIG. 20 illustrates aberration curves of the optical imaging system of FIG. 19.

FIG. 21 is a view illustrating an eleventh example of an optical imaging system.

FIG. 22 illustrates aberration curves of the optical imaging system of FIG. 21.

FIG. 23 is a view illustrating a twelfth example of an optical imaging system.

FIG. 24 illustrates aberration curves of the optical imaging system of FIG. 23.

FIG. 25 is a view illustrating a thirteenth example of an optical imaging system.

FIG. 26 illustrates aberration curves of the optical imaging system of FIG. 25.

FIG. 27 is a view illustrating a fourteenth example of an optical imaging system.

FIG. 28 illustrates aberration curves of the optical imaging system of FIG. 27.

FIG. 29 is a view illustrating a fifteenth example of an optical imaging system.

FIG. 30 illustrates aberration curves of the optical imaging system of FIG. 29.

FIG. 31 is a view illustrating a sixteenth example of an optical imaging system.

FIG. 32 illustrates aberration curves of the optical imaging system of FIG. 31.

FIG. 33 is a view illustrating a seventeenth example of an optical imaging system.

FIG. 34 illustrates aberration curves of the optical imaging system of FIG. 33.

FIG. 35 is a view illustrating an eighteenth example of an optical imaging system.

FIG. 36 illustrates aberration curves of the optical imaging system of FIG. 35.

FIG. 37 is a view illustrating a nineteenth example of an optical imaging system.

FIG. 38 illustrates aberration curves of the optical imaging system of FIG. 37.

FIG. 39 is a view illustrating a twentieth example of an optical imaging system.

FIG. 40 illustrates aberration curves of the optical imaging system of FIG. 39.

FIG. 41 is a view illustrating a twenty-first example of an optical imaging system.

FIG. 42 illustrates aberration curves of the optical imaging system of FIG. 41.

FIG. 43 is a view illustrating a twenty-second example of an optical imaging system.

FIG. 44 illustrates aberration curves of the optical imaging system of FIG. 43.

FIG. 45 is a view illustrating a twenty-third example of an optical imaging system.

4

FIG. 46 illustrates aberration curves of the optical imaging system of FIG. 45.

FIG. 47 is a view illustrating a twenty-fourth example of an optical imaging system.

FIG. 48 illustrates aberration curves of the optical imaging system of FIG. 47.

FIG. 49 is a view illustrating a twenty-fifth example of an optical imaging system.

FIG. 50 illustrates aberration curves of the optical imaging system of FIG. 49.

FIG. 51 is a view illustrating a twenty-sixth example of an optical imaging system.

FIG. 52 illustrates aberration curves of the optical imaging system of FIG. 51.

FIG. 53 is a view illustrating a twenty-seventh example of an optical imaging system.

FIG. 54 illustrates aberration curves of the optical imaging system of FIG. 53.

FIG. 55 is a view illustrating a twenty-eighth example of an optical imaging system.

FIG. 56 illustrates aberration curves of the optical imaging system of FIG. 55.

FIGS. 57 and 58 are cross-sectional views illustrating examples of an optical imaging system and a lens barrel coupled to each other.

FIG. 59 is a cross-sectional view illustrating an example of a seventh lens.

FIG. 60 is a cross-sectional view illustrating an example of a shape of a rib of a lens.

Throughout the drawings and the detailed description, the same reference numerals refer to the same elements. The drawings may not be to scale, and the relative size, proportions, and depiction of elements in the drawings may be exaggerated for clarity, illustration, and convenience.

DETAILED DESCRIPTION

The following detailed description is provided to assist the reader in gaining a comprehensive understanding of the methods, apparatuses, and/or systems described herein. However, various changes, modifications, and equivalents of the methods, apparatuses, and/or systems described herein will be apparent after an understanding of the disclosure of this application. For example, the sequences of operations described herein are merely examples, and are not limited to those set forth herein, but may be changed as will be apparent after an understanding of the disclosure of this application, with the exception of operations necessarily occurring in a certain order. Also, descriptions of features that are known in the art may be omitted for increased clarity and conciseness.

The features described herein may be embodied in different forms, and are not to be construed as being limited to the examples described herein. Rather, the examples described herein have been provided merely to illustrate some of the many possible ways of implementing the methods, apparatuses, and/or systems described herein that will be apparent after an understanding of the disclosure of this application.

Throughout the specification, when an element, such as a layer, region, or substrate, is described as being “on,” “connected to,” or “coupled to” another element, it may be directly “on,” “connected to,” or “coupled to” the other element, or there may be one or more other elements intervening therebetween. In contrast, when an element is described as being “directly on,” “directly connected to,” or

“directly coupled to” another element, there can be no other elements intervening therebetween.

As used herein, the term “and/or” includes any one and any combination of any two or more of the associated listed items.

Although terms such as “first,” “second,” and “third” may be used herein to describe various members, components, regions, layers, or sections, these members, components, regions, layers, or sections are not to be limited by these terms. Rather, these terms are only used to distinguish one member, component, region, layer, or section from another member, component, region, layer, or section. Thus, a first member, component, region, layer, or section referred to in examples described herein may also be referred to as a second member, component, region, layer, or section without departing from the teachings of the examples.

Spatially relative terms such as “above,” “upper,” “below,” and “lower” may be used herein for ease of description to describe one element’s relationship to another element as shown in the figures. Such spatially relative terms are intended to encompass different orientations of the device in use or operation in addition to the orientation depicted in the figures. For example, if the device in the figures is turned over, an element described as being “above” or “upper” relative to another element will then be “below” or “lower” relative to the other element. Thus, the term “above” encompasses both the above and below orientations depending on the spatial orientation of the device. The device may also be oriented in other ways (for example, rotated by 90 degrees or at other orientations), and the spatially relative terms used herein are to be interpreted accordingly.

The terminology used herein is for describing various examples only, and is not to be used to limit the disclosure. The articles “a,” “an,” and “the” are intended to include the plural forms as well, unless the context clearly indicates otherwise. The terms “comprises,” “includes,” and “has” specify the presence of stated features, numbers, operations, members, elements, and/or combinations thereof, but do not preclude the presence or addition of one or more other features, numbers, operations, members, elements, and/or combinations thereof.

Thicknesses, sizes, and shapes of lenses illustrated in the drawings may have been slightly exaggerated for convenience of explanation. In addition, the shapes of spherical surfaces or aspherical surfaces of the lenses described in the detailed description and illustrated in the drawings are merely examples. That is, the shapes of the spherical surfaces or the aspherical surfaces of the lenses are not limited to the examples described herein.

Numerical values of radii of curvature of lenses, thicknesses of lenses, distances between elements including lenses or surfaces, effective aperture radii of lenses, focal lengths, and diameters, thicknesses, and lengths of various elements are expressed in millimeters (mm), and angles are expressed in degrees. Thicknesses of lenses and distances between elements including lenses or surfaces are measured along the optical axis of the optical imaging system.

The term “effective aperture radius” as used in this application refers to a radius of a portion of a surface of a lens or other element (an object-side surface or an image-side surface of a lens or other element) through which light actually passes. The effective aperture radius is equal to a distance measured perpendicular to an optical axis of the surface between the optical axis of the surface and the outermost point on the surface through which light actually passes. Therefore, the effective aperture radius may be equal

to a radius of an optical portion of a surface, or may be smaller than the radius of the optical portion of the surface if light does not pass through a peripheral portion of the optical portion of the surface. The object-side surface and the image-side surface of a lens or other element may have different effective aperture radii.

In this application, unless stated otherwise, a reference to the shape of a lens surface means the shape of a paraxial region of the lens surface. A paraxial region of a lens surface is a central portion of the lens surface surrounding the optical axis of the lens surface in which light rays incident to the lens surface make a small angle θ to the optical axis and the approximations $\sin \theta \approx \theta$, $\tan \theta \approx \theta$, and $\cos \theta \approx 1$ are valid.

For example, a statement that the object-side surface of a lens is convex means that at least a paraxial region of the object-side surface of the lens is convex, and a statement that the image-side surface of the lens is concave means that at least a paraxial region of the image-side surface of the lens is concave. Therefore, even though the object-side surface of the lens may be described as convex, the entire object-side surface of the lens may not be convex, and a peripheral region of the object-side surface of the lens may be concave. Also, even though the image-side surface of the lens may be described as concave, the entire image-side surface of the lens may not be concave, and a peripheral region of the image-side surface of the lens may be convex.

An optical imaging system includes a plurality of lenses. For example, the optical imaging system includes a first lens, a second lens, a third lens, a fourth lens, a fifth lens, a sixth lens, and a seventh lens sequentially disposed in numerical order along an optical axis of the optical imaging system from an object side of the optical imaging system toward an imaging plane of the optical imaging system. Thus, the first lens is a lens closest to an object (or a subject) to be imaged by the optical imaging system, while the seventh lens is a lens closest to the imaging plane.

Each lens of the optical imaging system includes an optical portion and a rib. The optical portion of the lens is a portion of the lens that is configured to refract light, and is generally formed in a central portion of the lens. The rib of the lens is an edge portion of the lens that enables the lens to be mounted in a lens barrel and the optical axis of the lens to be aligned with the optical axis of the optical imaging system. The rib of the lens extends radially outward from the optical portion. The optical portions of the lenses are generally not in contact with each other. For example, the first to seventh lenses are mounted in the lens barrel so that they are spaced apart from one other by predetermined distances along the optical axis of the optical imaging system. The ribs of the lenses may be selectively in contact with each other. For example, the ribs of the first to fourth lenses, or the first to fifth lenses, or the second to fourth lenses, may be in contact with each other so that the optical axes of these lenses may be easily aligned with the optical axis of the optical imaging system.

Next, a configuration of the optical imaging system will be described.

The optical imaging system includes a plurality of lenses. For example, the optical imaging system includes a first lens, a second lens, a third lens, a fourth lens, a fifth lens, a sixth lens, and a seventh lens sequentially disposed in numerical order along an optical axis of the optical imaging system from an object side of the optical imaging system toward an imaging plane of the optical imaging system.

The optical imaging system further includes an image sensor and a filter. The image sensor forms an imaging plane

and converts light refracted by the first to seventh lenses into an electrical signal. The filter is disposed between the seventh lens and the imaging plane, and blocks infrared rays in the light refracted by the first to seventh lenses from being incident on the imaging plane.

The optical imaging system further includes a stop and spacers. The stop may be disposed in front of the first lens, or at a position of either an object-side surface or an image side-surface of one of the first to seventh lenses, or between two adjacent lenses of the first to seventh lenses, or between the object-side surface and the image-side surface of one of the first to seventh lenses, to adjust an amount of light incident on the imaging plane. Some examples may include two stops, one of which may be disposed in front of the first lens, or at the position of the object-side surface of the first lens, or between the object-side surface and the image-side surface of the first lens. Each of the spacers is disposed at a respective position between two lenses of the first to seventh lenses to maintain a predetermined distance between the two lenses. In addition, the spacers may be formed of a light-shielding material to block extraneous light from penetrating into the ribs of the lenses. There may be six or seven spacers. For example, a first spacer is disposed between the first lens and the second lens, a second spacer is disposed between the second lens and the third lens, a third spacer is disposed between the third lens and the fourth lens, a fourth spacer is disposed between the fourth lens and the fifth lens, a fifth spacer is disposed between the fifth lens and the sixth lens, and a sixth spacer is disposed between the sixth lens and the seventh lens. In addition, the optical imaging system may further include a seventh spacer disposed between the sixth lens and the sixth spacer.

Next, the lenses of the optical imaging system will be described.

The first lens has a refractive power. For example, the first lens has a positive refractive power or a negative refractive power. One surface of the first lens may be convex. For example, an object-side surface of the first lens may be convex. The first lens may include an aspherical surface. For example, one surface or both surfaces of the first lens may be aspherical.

The second lens has a refractive power. For example, the second lens has a positive refractive power or a negative refractive power. One surface or both surfaces of the second lens may be convex. For example, an object-side surface or both an object-side surface and an image-side surface of the second lens may be convex. The second lens may include an aspherical surface. For example, one surface or both surfaces of the second lens may be aspherical.

The third lens has a refractive power. For example, the third lens has a positive refractive power or a negative refractive power. One surface or both surfaces of the third lens may be convex. For example, an object-side surface, or an image-side surface, or both an object-side surface and an image-side surface of the third lens may be convex. The third lens may include an aspherical surface. For example, one surface or both surfaces of the third lens may be aspherical.

The fourth lens has a refractive power. For example, the fourth lens has a positive refractive power or a negative refractive power. One surface or both surfaces of the fourth lens may be convex. For example, an object-side surface, or an image-side surface, or both an object-side surface and an image-side surface of the fourth lens may be convex. The fourth lens may include an aspherical surface. For example, one surface or both surfaces of the fourth lens may be aspherical.

The fifth lens has a refractive power. For example, the fifth lens has a positive refractive power or a negative refractive power. One surface of the fifth lens may be convex. For example, an object-side surface or an image-side surface of the fifth lens may be convex. The fifth lens may include an aspherical surface. For example, one surface or both surfaces of the fifth lens may be aspherical.

The sixth lens has a refractive power. For example, the sixth lens has a positive refractive power or a negative refractive power. In some examples, one surface or both surfaces of the sixth lens may be convex. For example, an object-side surface or both an object-side surface and an image-side surface of the sixth lens may be convex. Also, in some examples, one surface or both surfaces of the sixth lens may be concave. For example, an image-side surface or both an object-side surface and an image-side surface of the sixth lens may be concave. At least one surface of the sixth lens may have at least one inflection point. An inflection point is a point where a lens surface changes from convex to concave, or from concave to convex. A number of inflection points is counted from a center of the lens to an outer edge of the optical portion of the lens. For example, at least one inflection point may be formed on either one or both of the object-side surface and the image-side surface of the sixth lens. Therefore, at least one surface of the sixth lens may have a paraxial region and a peripheral region having shapes that are different from each other. For example, a paraxial region of the image-side surface of the sixth lens may be concave, but a peripheral region thereof may be convex. The sixth lens may have an aspherical surface. For example, one surface or both surfaces of the sixth lens may be aspherical.

The seventh lens has a refractive power. For example, the seventh lens has a positive refractive power or a negative refractive power. One surface of the seventh lens may be concave. For example, an image-side surface or both an object-side surface and an image-side surface of the seventh lens may be concave. At least one surface of the seventh lens may have at least one inflection point. For example, at least one inflection point may be formed on either one or both of the object-side surface and the image-side surface of the seventh lens. Therefore, at least one surface of the seventh lens may have a paraxial region and a peripheral region having shapes that are different from each other. For example, a paraxial region of the image-side surface of the seventh lens may be concave, but a peripheral region thereof may be convex. The seventh lens may include an aspherical surface. For example, one surface or both surfaces of the seventh lens may be aspherical.

The lenses of the optical imaging system may be made of a light material having a high light transmittance. For example, the first to seventh lenses may be made of a plastic material. However, a material of the first to seventh lenses is not limited to the plastic material.

The aspherical surfaces of the first to seventh lenses may be represented by the following Equation 1:

$$Z = \frac{cY^2}{1 + \sqrt{1 - (1 + K)c^2Y^2}} + AY^4 + BY^6 + CY^8 + DY^{10} + EY^{12} + FY^{14} + GY^{16} + HY^{18} + \dots \quad (1)$$

In Equation 1, c is a curvature of a lens surface and is equal to an inverse of a radius of curvature of the lens surface at an optical axis of the lens surface, K is a conic constant, Y is a distance from a certain point on an aspherical

surface of the lens to an optical axis of the lens in a direction perpendicular to the optical axis, A to H are aspherical constants, and Z (or sag) is a distance between the certain point on the aspherical surface of the lens at the distance Y to the optical axis and a tangential plane perpendicular to the optical axis meeting the apex of the aspherical surface of the lens. Some of the examples disclosed in this application include an aspherical constant J. An additional term of JY^{20} may be added to the right side of Equation 1 to reflect the effect of the aspherical constant J.

The optical imaging system may satisfy one or more of the following Conditional Expressions 1 to 6:

$$0.1 < L1w/L7w < 0.4 \quad (\text{Conditional Expression 1})$$

$$0.5 < S6d/f < 1.4 \quad (\text{Conditional Expression 2})$$

$$0.4 < L1TR/L7TR < 0.8 \quad (\text{Conditional Expression 3})$$

$$0.5 < L1234TRavg/L7TR < 0.9 \quad (\text{Conditional Expression 4})$$

$$0.5 < L12345TRavg/L7TR < 0.9 \quad (\text{Conditional Expression 5})$$

$$1 < |f134567 - f|/f \quad (\text{Conditional Expression 6})$$

In the above Conditional Expressions, L1w is a weight of the first lens, and L7w is a weight of the seventh lens.

S6d is an inner diameter of the sixth spacer, and f is an overall focal length of the optical imaging system.

L1TR is an overall outer diameter of the first lens, and L7TR is an overall outer diameter of the seventh lens. The overall outer diameter of a lens is a diameter of the lens including both the optical portion of the lens and the rib of the lens.

L1234TRavg is an average value of overall outer diameters of the first to fourth lenses, and L12345TRavg is an average value of overall outer diameters of the first to fifth lenses.

f134567 is a composite focal length of the first to seventh lenses calculated with an index of refraction of the second lens set to 1.0, which is substantially equal to an index of refraction of air. When the index of refraction of the second lens is set to 1.0, the second lens does not refract light. Thus, by comparing f134567 with f, which is the overall focal length of the optical system, it is possible to evaluate the effect of the second lens on f. For example, the second lens may shorten f, or lengthen f, or have no effect on f. In other words, f134567 may be greater than f, or less than f, or equal to f.

Conditional Expressions 1 and 3 specify ranges of a weight ratio and an overall outer diameter ratio between the first lens and the seventh lens to facilitate a self-alignment between the lenses and an alignment by a lens barrel.

Conditional Expression 2 specifies a range of a ratio of the inner diameter of the sixth spacer to the overall focal length of the optical imaging system for minimizing a flare phenomenon.

Conditional Expressions 4 and 5 specify overall outer diameter ratios between the lenses to facilitate aberration correction.

Conditional Expression 6 specifies a lower limit of a degree of shortening of f, which is the overall focal length of the optical imaging system, by the second lens. The lower limit of 1 for $|f134567 - f|/f$ in Conditional Expression 6 corresponds to an example in which the second lens shortens f to 50% of f134567. Thus, Conditional Expression 6 covers examples in which f is 50% or less of f134567.

The optical imaging system may also satisfy one or more of the following Conditional Expressions 7 to 12:

$$0.1 < L1w/L7w < 0.3 \quad (\text{Conditional Expression 7})$$

$$0.5 < S6d/f < 1.2 \quad (\text{Conditional Expression 8})$$

$$0.4 < L1TR/L7TR < 0.7 \quad (\text{Conditional Expression 9})$$

$$0.5 < L1234TRavg/L7TR < 0.75 \quad (\text{Conditional Expression 10})$$

$$0.5 < L12345TRavg/L7TR < 0.76 \quad (\text{Conditional Expression 11})$$

$$1 < |f134567 - f|/f < 100 \quad (\text{Conditional Expression 12})$$

Conditional Expressions 7 to 12 are the same as Conditional Expressions 1 to 6, except that Conditional Expressions 7 to 12 specify narrower ranges.

The optical imaging system may also satisfy one or more of the following Conditional Expressions 13 to 33:

$$0.01 < R1/R4 < 1.3 \quad (\text{Conditional Expression 13})$$

$$0.1 < R1/R5 < 0.7 \quad (\text{Conditional Expression 14})$$

$$0.05 < R1/R6 < 0.9 \quad (\text{Conditional Expression 15})$$

$$0.2 < R1/R11 < 1.2 \quad (\text{Conditional Expression 16})$$

$$0.8 < R1/R14 < 1.2 \quad (\text{Conditional Expression 17})$$

$$0.6 < (R11 + R14)/(2 * R1) < 3.0 \quad (\text{Conditional Expression 18})$$

$$0.4 < D13/D57 < 1.2 \quad (\text{Conditional Expression 19})$$

$$0.1 < (1/f1 + 1/f2 + 1/f3 + 1/f4 + 1/f5 + 1/f6 + 1/f7) * f < 0.8 \quad (\text{Conditional Expression 20})$$

$$0.1 < (1/f1 + 1/f2 + 1/f3 + 1/f4 + 1/f5 + 1/f6 + 1/f7) * TTL < 1.0 \quad (\text{Conditional Expression 21})$$

$$0.2 < TD1/D67 < 0.8 \quad (\text{Conditional Expression 22})$$

$$0.1 < (R11 + R14)/(R5 + R6) < 1.0 \quad (\text{Conditional Expression 23})$$

$$SD12 < SD34 \quad (\text{Conditional Expression 24})$$

$$SD56 < SD67 \quad (\text{Conditional Expression 25})$$

$$SD56 < SD34 \quad (\text{Conditional Expression 26})$$

$$0.6 < TTL/(2 * (IMG HT)) < 0.9 \quad (\text{Conditional Expression 27})$$

$$0.2 < \sum SD / \sum TD < 0.7 \quad (\text{Conditional Expression 28})$$

$$0 < \min(f1; f3) / \max(f4; f7) < 0.4 \quad (\text{Conditional Expression 29})$$

$$0.4 < (\sum TD) / TTL < 0.7 \quad (\text{Conditional Expression 30})$$

$$0.7 < SL/TTL < 1.0 \quad (\text{Conditional Expression 31})$$

$$0.81 < f12/f123 < 0.96 \quad (\text{Conditional Expression 32})$$

$$0.6 < f12/f1234 < 0.84 \quad (\text{Conditional Expression 33})$$

In the above Conditional Expressions, R1 is a radius of curvature of an object-side surface of the first lens, R4 is a radius of curvature of an image-side surface of the second lens, R5 is a radius of curvature of an object-side surface of the third lens, R6 is a radius of curvature of an image-side surface of the third lens, R11 is a radius of curvature of an object-side surface of the sixth lens, and R14 is a radius of curvature of an image-side surface of the seventh lens.

D13 is a distance along an optical axis of the optical imaging system from the object-side surface of the first lens to the image-side surface of the third lens, and D57 is a distance along the optical axis from an object-side surface of the fifth lens to the image-side surface of the seventh lens.

11

f1 is a focal length of the first lens, f2 is a focal length of the second lens, f3 is a focal length of the third lens, f4 is a focal length of the fourth lens, f5 is a focal length of the fifth lens, f6 is a focal length of the sixth lens, f7 is a focal length of the seventh lens, f is an overall focal length of the optical imaging system, and TTL is a distance along the optical axis from the object-side surface of the first lens to an imaging plane of an image sensor of the optical imaging system.

TD1 is a thickness along the optical axis of the first lens, and D67 is a distance along the optical axis from the object-side surface of the sixth lens to the image-side surface of the seventh lens.

SD12 is a distance along the optical axis from an image-side surface of the first lens to an object-side surface of the second lens, SD34 is a distance along the optical axis from the image-side surface of the third lens to an object-side surface of the fourth lens, SD56 is a distance along the optical axis from an image-side surface of the fifth lens to the object-side surface of the sixth lens, and SD67 is a distance along the optical axis from an image-side surface of the sixth lens to an object-side surface of the seventh lens.

IMG HT is one-half of a diagonal length of the imaging plane of the image sensor.

Σ SD is a sum of air gaps along the optical axis between the lenses, and Σ TD is a sum of thicknesses along the optical axis of the lenses. An air gap is a distance along the optical axis between adjacent lenses.

$\min(f1:f3)$ is a minimum value of absolute values of the focal lengths of the first to third lenses, and $\max(f4:f7)$ is a maximum value of absolute values of the focal lengths of the fourth to seventh lenses.

SL is a distance along the optical axis from a stop to the imaging plane of the image sensor.

f12 is a composite focal length of the first and second lenses, f123 is a composite focal length of the first to third lenses, and f1234 is a composite focal length of the first to fourth lenses.

Conditional Expression 13 specifies a design range of the second lens for minimizing aberration caused by the first lens. For example, it is difficult to expect a sufficient correction of longitudinal spherical aberration for the second lens having a radius of curvature that exceeds the upper limit value of Conditional Expression 13, and it is difficult to expect a sufficient correction of astigmatic field curves for the second lens having a radius of curvature that is below the lower limit value of Conditional Expression 13.

Conditional Expressions 14 and 15 specify a design range of the third lens for minimizing aberration caused by the first lens. For example, it is difficult to expect a sufficient correction of longitudinal spherical aberration for the third lens having a radius of curvature that exceeds the upper limit value of Conditional Expression 14 or 15, and it is difficult to expect a correction of astigmatic field curves for the third lens having a radius of curvature that is below the lower limit value of Conditional Expression 14 or 15.

Conditional Expression 16 specifies a design range of the sixth lens for minimizing aberration caused by the first lens. For example, it is difficult to expect a sufficient correction of longitudinal spherical aberration for the sixth lens having a radius of curvature that exceeds the upper limit value of Conditional Expression 16, and the sixth lens having a radius of curvature that is below the lower limit value of Conditional Expression 16 is apt to cause a flare phenomenon.

Conditional Expression 17 specifies a design range of the seventh lens for minimizing aberration caused by the first lens. For example, it is difficult to expect a sufficient

12

correction of longitudinal spherical aberration for the seventh lens having a radius of curvature that exceeds the upper limit value of Conditional Expression 17, and the seventh lens having a radius of curvature that is below the lower limit value of Conditional Expression 17 tends to cause a curvature of the imaging plane.

Conditional Expression 18 specifies a ratio of a sum of radii of curvature of the sixth lens and the seventh lens to twice a radius of curvature of the first lens for correcting the longitudinal spherical aberration and achieving excellent optical performance.

Conditional Expression 19 specifies a ratio of an optical imaging system mountable in a small terminal. For example, an optical imaging system having a ratio that exceeds the upper limit value of Conditional Expression 19 may cause a problem that the total length of the optical imaging system becomes long, and an optical imaging system having a ratio that is below the lower limit value of Conditional Expression 19 may cause a problem that a size of a lateral cross-section of the optical imaging system becomes large.

Conditional Expressions 20 and 21 specify a refractive power ratio of the first to seventh lenses for facilitating mass production of the optical imaging system. For example, an optical imaging system that exceeds the upper limit value of Conditional Expression 20 or 21 or is below the lower limit value of Conditional Expression 20 or 21 is difficult to commercialize because the refractive power of one or more of the first to seventh lenses is too great.

Conditional Expression 22 specifies a thickness range of the first lens for implementing a compact optical imaging system. For example, the first lens having a thickness that exceeds the upper limit value of Conditional Expression 22 or is below the lower limit value of Conditional Expression 22 is too thick or too thin to be manufactured.

Conditional Expression 24 specifies a design condition of the first to fourth lenses for improving chromatic aberration. For example, a case in which a distance between the first lens and the second lens is shorter than a distance between the third lens and the fourth lens is advantageous for improving the chromatic aberration.

Conditional Expressions 27 to 30 specify design conditions for implementing a compact optical imaging system. For example, lenses that deviate from the numerical range of Conditional Expression 28 or 30 are difficult to form by injection molding and process.

Conditional Expressions 31 to 33 specify design conditions of an optical imaging system in consideration of a position of the stop. For example, an optical imaging system that does not satisfy one or more of Conditional Expressions 31 to 33 may have a longer overall length due to the refractive power of the lenses disposed behind the stop.

Next, various examples of the optical imaging system will be described. In the tables that appear in the following examples, S1 denotes an object-side surface of the first lens, S2 denotes an image-side surface of the first lens, S3 denotes an object-side surface of the second lens, S4 denotes an image-side surface of the second lens, S5 denotes an object-side surface of the third lens, S6 denotes an image-side surface of the third lens, S7 denotes an object-side surface of the fourth lens, S8 denotes an image-side surface of the fourth lens, S9 denotes an object-side surface of the fifth lens, S10 denotes an image-side surface of the fifth lens, S11 denotes an object-side surface of the sixth lens, S12 denotes an image-side surface of the sixth lens, S13 denotes an object-side surface of the seventh lens, S14 denotes an image-side surface of the seventh lens, S15 denotes an

object-side surface of the filter, S16 denotes an image-side surface of the filter, and S17 denotes the imaging plane.

First Example

FIG. 1 is a view illustrating a first example of an optical imaging system, and FIG. 2 illustrates aberration curves of the optical imaging system of FIG. 1.

An optical imaging system 1 includes a first lens 1001, a second lens 2001, a third lens 3001, a fourth lens 4001, a fifth lens 5001, a sixth lens 6001, and a seventh lens 7001.

The first lens 1001 has a positive refractive power, and an object-side surface thereof is convex and an image-side surface thereof is concave. The second lens 2001 has a negative refractive power, and an object-side surface thereof is convex and an image-side surface thereof is concave. The third lens 3001 has a positive refractive power, and an object-side surface thereof is convex and an image-side surface thereof is convex. The fourth lens 4001 has a negative refractive power, and an object-side surface thereof is convex and an image-side surface thereof is concave. The fifth lens 5001 has a negative refractive power, and an object-side surface thereof is convex and an image-side surface thereof is concave. The sixth lens 6001 has a positive refractive power, and an object-side surface thereof is convex and an image-side surface thereof is convex. In addition,

at least one inflection point is formed on either one or both of the object-side surface and the image-side surface of the sixth lens 6001. The seventh lens 7001 has a negative refractive power, and an object-side surface thereof is concave and an image-side surface thereof is concave. In addition, one inflection point is formed on each of the object-side surface and the image-side surface of the seventh lens 7001.

The optical imaging system 1 further includes a stop, a filter 8001, and an image sensor 9001. The stop is disposed between the first lens 1001 and the second lens 2001 to adjust an amount of light incident on the image sensor 9001. The filter 8001 is disposed between the seventh lens 7001 and the image sensor 9001 to block infrared rays. The image sensor 9001 forms an imaging plane on which an image of a subject is formed. Although not illustrated in FIG. 1, the stop is disposed at a distance of 0.9035 mm from the object-side surface of the first lens 1001 toward the imaging plane of the optical imaging system 1. This distance is equal to TTL-SL and can be calculated from the values of TTL and SL for Example 1 listed in Table 57 that appears later in this application.

Table 1 below shows physical properties of the lenses and other elements of the optical imaging system of FIG. 1, and Table 2 below shows aspherical surface coefficients of the lenses of FIG. 1.

TABLE 1

Surface No.	Element	Radius of Curvature	Thickness/Distance	Index of Refraction	Abbe Number	Effective Aperture Radius
S1	First	2.0536	0.9035	1.546	56.114	1.568
S2	Lens (Stop)	8.6990	0.1210			1.513
S3	Second	5.7984	0.2300	1.669	20.353	1.411
S4	Lens	3.2822	0.3720			1.251
S5	Third	18.2423	0.5020	1.546	56.114	1.280
S6	Lens	-30.8318	0.1292			1.403
S7	Fourth	9.4556	0.2600	1.669	20.353	1.421
S8	Lens	6.8529	0.2842			1.592
S9	Fifth	114.7177	0.3399	1.669	20.353	1.703
S10	Lens	7.7503	0.2357			1.957
S11	Sixth	3.8296	0.8015	1.546	56.114	2.275
S12	Lens	-2.3157	0.5095			2.531
S13	Seventh	-2.7231	0.3800	1.546	56.114	3.250
S14	Lens	2.7638	0.1236			3.501
S15	Filter	Infinity	0.1100	1.519	64.197	3.788
S16		Infinity	0.6860			3.823
S17	Imaging Plane	Infinity	0.0120			4.187

TABLE 2

	K	A	B	C	D	E	F	G	H	J
S1	-1.0628	0.0139	0.0094	-0.0141	0.0168	-0.0121	0.0052	-0.0012	0.0001	0
S2	10.994	-0.0496	0.0432	-0.0268	0.0108	-0.0042	0.0015	-0.0004	3E-05	0
S3	0	0	0	0	0	0	0	0	0	0
S4	-1.5785	-0.0696	0.0645	0.0114	-0.0726	0.0789	-0.0411	0.0103	-0.0006	0
S5	0	-0.025	0.0128	-0.0683	0.1144	-0.1136	0.0622	-0.0169	0.0018	0
S6	-95	-0.0612	-0.0021	0.0182	-0.0574	0.0781	-0.0583	0.0229	-0.0037	0
S7	0	-0.1305	0.0429	-0.1213	0.1851	-0.1579	0.0797	-0.0225	0.0028	0
S8	0	-0.1024	0.076	-0.1473	0.1804	-0.1345	0.0601	-0.015	0.0016	0
S9	0	-0.1299	0.161	-0.1553	0.1065	-0.0538	0.0179	-0.0035	0.0003	0
S10	3.6183	-0.1952	0.1484	-0.1106	0.0696	-0.0319	0.0091	-0.0014	9E-05	0
S11	-19.534	-0.0262	-0.0142	0.0017	0.002	-0.0013	0.0003	-3E-05	6E-07	0
S12	-0.7774	0.0934	-0.0701	0.0245	-0.0058	0.0012	0.0002	2E-05	-7E-07	0
S13	-17.906	-0.104	0.0087	0.0102	-0.0036	0.0006	-5E-05	2E-06	-4E-08	0
S14	-0.5975	-0.11	0.0366	-0.009	0.0016	-0.0002	2E-05	-2E-06	6E-08	-1.12E-09

FIG. 3 is a view illustrating a second example of an optical imaging system, and FIG. 4 illustrates aberration curves of the optical imaging system of FIG. 3.

An optical imaging system 2 includes a first lens 1002, a second lens 2002, a third lens 3002, a fourth lens 4002, a fifth lens 5002, a sixth lens 6002, and a seventh lens 7002.

The first lens 1002 has a positive refractive power, and an object-side surface thereof is convex and an image-side surface thereof is concave. The second lens 2002 has a positive refractive power, and an object-side surface thereof is convex and an image-side surface thereof is convex. The third lens 3002 has a negative refractive power, and an object-side surface thereof is convex and an image-side surface thereof is concave. The fourth lens 4002 has a positive refractive power, and an object-side surface thereof is concave and an image-side surface thereof is convex. The fifth lens 5002 has a positive refractive power, and an object-side surface thereof is convex and an image-side surface thereof is concave. The sixth lens 6002 has a negative refractive power, and an object-side surface thereof is convex and an image-side surface thereof is concave. In addition, at least one inflection point is formed on either one

or both of the object-side surface and the image-side surface of the sixth lens 6002. The seventh lens 7002 has a positive refractive power, and an object-side surface thereof is convex and an image-side surface thereof is concave. In addition, two inflection points are formed on the object-side surface of the seventh lens 7002, and one inflection point is formed on the image-side surface of the seventh lens 7002.

The optical imaging system 2 further includes a stop, a filter 8002, and an image sensor 9002. The stop is disposed between the second lens 2002 and the third lens 3002 to adjust an amount of light incident on the image sensor 9002. The filter 8002 is disposed between the seventh lens 7002 and the image sensor 9002 to block infrared rays. The image sensor 9002 forms an imaging plane on which an image of a subject is formed. Although not illustrated in FIG. 3, the stop is disposed at distance of 1.2514 mm from the object-side surface of the first lens 1002 toward the imaging plane of the optical imaging system 2. This distance is equal to TTL-SL and can be calculated from the values of TTL and SL for Example 2 listed in Table 57 that appears later in this application.

Table 3 below shows physical properties of the lenses and other elements of the optical imaging system of FIG. 3, and Table 4 below shows aspherical surface coefficients of the lenses of FIG. 3.

TABLE 3

Surface No.	Element	Radius of Curvature	Thickness/Distance	Index of Refraction	Abbe Number	Effective Aperture Radius
S1	First	2.0977	0.4848	1.546	56.114	1.410
S2	Lens	3.2123	0.1235			1.350
S3	Second	2.8957	0.6231	1.546	56.114	1.310
S4	Lens	-16.0261	0.0200			1.271
S5	(Stop)	4.6472	0.2000	1.679	19.236	1.157
S6	Third Lens	2.3076	0.6031			1.095
S7	Fourth	-1200.00	0.2984	1.679	19.236	1.270
S8	Lens	-1200.00	0.2107			1.456
S9	Fifth	3.3656	0.3072	1.546	56.114	1.712
S10	Lens	3.2933	0.2365			2.000
S11	Sixth	3.2587	0.3776	1.679	19.236	2.150
S12	Lens	2.6817	0.1409			2.500
S13	Seventh	1.5589	0.5411	1.537	53.955	2.871
S14	Lens	1.3718	0.2430			3.050
S15	Filter	Infinity	0.1100	1.519	64.166	3.347
S16		Infinity	0.6673			3.379
S17	Imaging Plane	Infinity	0.0026			3.708

TABLE 4

	K	A	B	C	D	E	F	G	H	J
S1	-7.583	0.0707	-0.0815	0.0542	-0.0479	0.0209	-0.0011	-0.0013	0.0002	0
S2	-20.327	-0.0052	-0.1116	0.0603	0.0221	-0.0313	0.0098	-0.0002	-0.0003	0
S3	-0.2671	-0.0365	-0.0311	-0.0159	0.08	-0.0164	-0.04	0.0265	-0.0051	0
S4	0	0.0221	-0.096	0.0722	0.0909	-0.2138	0.1659	-0.0596	0.0083	0
S5	-4.5253	-0.0697	0.0432	-0.146	0.4306	-0.6073	0.4481	-0.1664	0.0247	0
S6	0.5431	-0.098	0.1133	-0.1737	0.2753	-0.3038	0.2109	-0.0818	0.0149	0
S7	0	-0.0194	-0.0742	0.1045	-0.1099	0.1045	-0.0888	0.0459	-0.0098	0
S8	0	-0.0129	-0.0975	0.0464	0.0472	-0.0702	0.033	-0.0054	0	0
S9	-43.017	0.1335	-0.1604	0.0703	-0.0277	0.0168	-0.01	0.003	-0.0003	0
S10	-5.2037	-0.0285	0.0684	-0.1295	0.1018	-0.0463	0.0125	-0.0018	0.0001	0
S11	-1.699	0.0274	-0.1873	0.1887	-0.126	0.0512	-0.0118	0.0014	-7E-05	0
S12	-0.0013	-0.0788	-0.0314	0.0355	-0.0206	0.0072	-0.0014	0.0001	-6E-06	0
S13	-0.8015	-0.4138	0.198	-0.0635	0.0157	-0.003	0.0004	-4E-05	2E-06	-5E-08
S14	-1.2781	-0.3	0.1664	-0.0696	0.021	-0.0044	0.0006	-5E-05	3E-06	-5E-08

FIG. 5 is a view illustrating a third example of an optical imaging system, and FIG. 6 illustrates aberration curves of the optical imaging system of FIG. 5.

An optical imaging system 3 includes a first lens 1003, a second lens 2003, a third lens 3003, a fourth lens 4003, a fifth lens 5003, a sixth lens 6003, and a seventh lens 7003.

The first lens 1003 has a positive refractive power, and an object-side surface thereof is convex and an image-side surface thereof is concave. The second lens 2003 has a positive refractive power, and an object-side surface thereof is convex and an image-side surface thereof is convex. The third lens 3003 has a negative refractive power, and an object-side surface thereof is convex and an image-side surface thereof is concave. The fourth lens 4003 has a positive refractive power, and an object-side surface thereof is concave and an image-side surface thereof is convex. The fifth lens 5003 has a positive refractive power, and an object-side surface thereof is convex and an image-side surface thereof is concave. The sixth lens 6003 has a negative refractive power, and an object-side surface thereof is convex and an image-side surface thereof is concave. In addition, at least one inflection point is formed on either one

or both of the object-side surface and the image-side surface of the sixth lens 6003. The seventh lens 7003 has a positive refractive power, and an object-side surface thereof is convex and an image-side surface thereof is concave. In addition, two inflection points are formed on the object-side surface of the seventh lens 7003, and one inflection point is formed on the image-side surface of the seventh lens 7003.

The optical imaging system 3 further includes a stop, a filter 8003, and an image sensor 9003. The stop is disposed between the second lens 2003 and the third lens 3003 to adjust an amount of light incident on the image sensor 9003. The filter 8003 is disposed between the seventh lens 7003 and the image sensor 9003 to block infrared rays. The image sensor 9003 forms an imaging plane on which an image of a subject is formed. Although not illustrated in FIG. 5, the stop is disposed at a distance of 1.4250 mm from the object-side surface of the first lens 1003 toward the imaging plane of the optical imaging system 3. This distance is equal to TTL-SL and can be calculated from the values of TTL and SL for Example 3 listed in Table 57 that appears later in this application.

Table 5 below shows physical properties of the lenses and other elements of the optical imaging system of FIG. 5, and Table 6 below shows aspherical surface coefficients of the lenses of FIG. 5.

TABLE 5

Surface No.	Element	Radius of Curvature	Thickness/Distance	Index of Refraction	Abbe Number	Effective Aperture Radius
S1	First	2.3706	0.5431	1.546	56.114	1.572
S2	Lens	3.8377	0.1516			1.517
S3	Second	3.4329	0.7078	1.546	56.114	1.478
S4	Lens	-17.0251	0.0225			1.428
S5	(Stop)	5.1429	0.2247	1.679	19.236	1.300
S6	Third Lens	2.5333	0.5888			1.230
S7	Fourth	-1446.167	0.3404	1.679	19.236	1.404
S8	Lens	-1446.167	0.2070			1.600
S9	Fifth	3.6434	0.3264	1.546	56.114	1.857
S10	Lens	3.8224	0.3171			2.199
S11	Sixth	3.8509	0.4406	1.679	19.236	2.415
S12	Lens	3.0494	0.1774			2.808
S13	Seventh	1.7430	0.6133	1.537	53.955	3.115
S14	Lens	1.5635	0.2466			3.314
S15	Filter	Infinity	0.1100	1.519	64.166	3.655
S16		Infinity	0.8047			3.688
S17	Imaging Plane	Infinity	0.0051			4.075

TABLE 6

	K	A	B	C	D	E	F	G	H	J
S1	-7.5196	0.0476	-0.039	0.0108	-0.0002	-0.006	0.0045	-0.0012	0.0001	0
S2	-19.661	-0.0106	-0.0481	0.0183	0.0105	-0.0109	0.0039	-0.0006	3E-05	0
S3	0.042	-0.0249	-0.0196	0.0094	0.0041	0.0108	-0.014	0.0056	-0.0008	0
S4	0	0.0098	-0.0507	0.0341	0.0229	-0.0518	0.0341	-0.0103	0.0012	0
S5	-5.6502	-0.0476	0.0152	-0.0398	0.11	-0.1327	0.082	-0.0252	0.0031	0
S6	0.5327	-0.067	0.0583	-0.0705	0.0922	-0.0854	0.0499	-0.0161	0.0024	0
S7	0	-0.0158	-0.0083	-0.0305	0.0756	-0.0736	0.035	-0.0077	0.0005	0
S8	0	-0.0099	-0.0427	0.0077	0.0285	-0.0272	0.01	-0.0013	0	0
S9	-44.395	0.1048	-0.1251	0.08	-0.0437	0.0187	-0.0058	0.001	-7E-05	0
S10	-4.0715	-0.0175	0.0211	-0.0368	0.0252	-0.01	0.0024	-0.0003	2E-05	0
S11	-1.1211	0.0034	-0.0742	0.0637	-0.0381	0.0134	-0.0026	0.0003	-1E-05	0
S12	0.0464	-0.092	0.0339	-0.0168	0.0044	-0.0005	1E-05	3E-06	-2E-07	0
S13	-0.795	-0.2987	0.11	-0.0259	0.0046	-0.0007	7E-05	-5E-06	2E-07	-5E-09
S14	-1.3233	-0.199	0.0846	-0.0285	0.0073	-0.0013	0.0002	-1E-05	5E-07	-9E-09

FIG. 7 is a view illustrating a fourth example of an optical imaging system, and FIG. 8 illustrates aberration curves of the optical imaging system of FIG. 7.

An optical imaging system 4 includes a first lens 1004, a second lens 2004, a third lens 3004, a fourth lens 4004, a fifth lens 5004, a sixth lens 6004, and a seventh lens 7004.

The first lens 1004 has a positive refractive power, and an object-side surface thereof is convex and an image-side surface thereof is concave. The second lens 2004 has a positive refractive power, and an object-side surface thereof is convex and an image-side surface thereof is convex. The third lens 3004 has a negative refractive power, and an object-side surface thereof is convex and an image-side surface thereof is concave. The fourth lens 4004 has a negative refractive power, and an object-side surface thereof is concave and an image-side surface thereof is convex. The fifth lens 5004 has a positive refractive power, and an object-side surface thereof is convex and an image-side surface thereof is concave. The sixth lens 6004 has a negative refractive power, and an object-side surface thereof is convex and an image-side surface thereof is concave. In addition, at least one inflection point is formed on either one or both of the object-side surface and the image-side surface of the sixth lens 6004. The seventh lens 7004 has a positive refractive power, and an object-side surface thereof is convex and an image-side surface thereof is concave. In addition, two inflection points are formed on the object-side surface of the seventh lens 7004, and one inflection point is formed on the image-side surface of the seventh lens 7004.

TABLE 7

Surface No.	Element	Radius of Curvature	Thick-ness/ Dis-tance	Index of Refraction	Abbe Number	Effective Aperture Radius
S1	First	1.9512	0.4488	1.546	56.114	1.307
S2	Lens	3.1152	0.1260			1.253
S3	Second	2.8686	0.5753	1.546	56.114	1.214
S4	Lens	-12.9825	0.0186			1.180
S5	(Stop)	4.5064	0.1856	1.679	19.236	1.074
S6	Third	2.1969	0.5197			1.016
S7	Lens					
S7	Fourth	-2108.865	0.2796	1.679	19.236	1.179
S8	Lens	-6755.436	0.1715			1.338
S9	Fifth	3.1135	0.2734	1.546	56.114	1.528
S10	Lens	3.2672	0.2417			1.808
S11	Sixth	3.2228	0.3650	1.679	19.236	1.996
S12	Lens	2.5388	0.1438			2.320
S13	Seventh	1.4451	0.5122	1.537	53.955	2.500
S14	Lens	1.2680	0.2501			2.738
S15	Filter	Infinity	0.1100	1.519	64.166	2.940
S16		Infinity	0.5924			2.971
S17	Imaging Plane	Infinity	0.0054			3.251

TABLE 8

	K	A	B	C	D	E	F	G	H	J
S1	-7.5279	0.0857	-0.105	0.0528	-0.0256	-0.0221	0.0379	-0.0166	0.0023	0
S2	-19.893	-0.0142	-0.1337	0.0682	0.0621	-0.0783	0.0306	-0.0031	-0.0006	0
S3	-0.0142	-0.0449	-0.0418	-0.0147	0.1136	0.012	-0.1333	0.0892	-0.0193	0
S4	0	0.0281	-0.189	0.276	-0.0808	-0.2297	0.2908	-0.1382	0.024	0
S5	-6.2325	-0.0763	-0.0054	-0.0795	0.6054	-1.1875	1.107	-0.5047	0.0912	0
S6	0.4782	-0.115	0.1396	-0.2676	0.5637	-0.7991	0.6898	-0.325	0.0682	0
S7	0	-0.0188	-0.0772	0.0717	0.0184	-0.081	0.0225	0.0277	-0.0139	0
S8	0	-0.0127	-0.1356	0.0837	0.0781	-0.1502	0.0847	-0.0163	0	0
S9	-49.08	0.1815	-0.3205	0.2837	-0.2161	0.1317	-0.0595	0.0158	-0.0017	0
S10	-5.4303	-0.0205	0.025	-0.1003	0.1046	-0.0624	0.0222	-0.0043	0.0003	0
S11	-1.136	0.0314	-0.2615	0.3261	-0.2695	0.133	-0.0369	0.0053	-0.0003	0
S12	0.0272	-0.1293	0.0241	5E-05	-0.0123	0.0085	-0.0024	0.0003	-2E-05	0
S13	-0.8	-0.5247	0.2994	-0.1227	0.0414	-0.0108	0.002	-0.0002	2E-05	-4E-07
S14	-1.3207	-0.3666	0.2425	-0.1248	0.0468	-0.0121	0.002	-0.0002	1E-05	-3E-07

The optical imaging system 4 further includes a stop, a filter 8004, and an image sensor 9004. The stop is disposed between the second lens 2004 and the third lens 3004 to adjust an amount of light incident on the image sensor 9004. The filter 8004 is disposed between the seventh lens 7004 and the image sensor 9004 to block infrared rays. The image sensor 9004 forms an imaging plane on which an image of a subject is formed. Although not illustrated in FIG. 7, the stop is disposed at a distance of 1.1686 mm from the object-side surface of the first lens 1004 toward the imaging plane of the optical imaging system 4. This distance is equal to TTL-SL and can be calculated from the values of TTL and SL for Example 4 listed in Table 57 that appears later in this application.

Table 7 below shows physical properties of the lenses and other elements of the optical imaging system of FIG. 7, and Table 8 below shows aspherical surface coefficients of the lenses of FIG. 7.

Fifth Example

FIG. 9 is a view illustrating a fifth example of an optical imaging system, and FIG. 10 illustrates aberration curves of the optical imaging system of FIG. 9.

An optical imaging system 5 includes a first lens 1005, a second lens 2005, a third lens 3005, a fourth lens 4005, a fifth lens 5005, a sixth lens 6005, and a seventh lens 7005.

The first lens 1005 has a negative refractive power, and an object-side surface thereof is convex and an image-side surface thereof is concave. The second lens 2005 has a positive refractive power, and an object-side surface thereof is convex and an image-side surface thereof is concave. The third lens 3005 has a negative refractive power, and an object-side surface thereof is convex and an image-side surface thereof is concave. The fourth lens 4005 has a negative refractive power, and an object-side surface thereof

is convex and an image-side surface thereof is concave. The fifth lens **5005** has a positive refractive power, and an object-side surface thereof is convex and an image-side surface thereof is concave. The sixth lens **6005** has a positive refractive power, and an object-side surface thereof is convex and an image-side surface thereof is convex. In addition, at least one inflection point is formed on either one or both of the object-side surface and the image-side surface of the sixth lens **6005**. The seventh lens **7005** has a negative refractive power, and an object-side surface thereof is concave and an image-side surface thereof is concave. In addition, one inflection point is formed on each of the

TABLE 9-continued

Surface No.	Element	Radius of Curvature	Thickness/Distance	Index of Refraction	Abbe Number	Effective Aperture Radius
S13	Seventh	-4.7165	0.3600	1.546	56.114	2.780
S14	Lens	1.8919	0.1457			2.998
S15	Filter	Infinity	0.1100	1.519	64.166	3.353
S16		Infinity	0.6600			3.385
S17	Imaging Plane	Infinity	0.0100			3.712

TABLE 10

	K	A	B	C	D	E	F	G	H
S1	-3.5715	0.0005	0.0011	-0.0181	0.0025	0.0107	-0.0084	0.0026	-0.0003
S2	-9.1496	-0.0513	-0.0055	0.0116	0.0161	-0.0207	0.0078	-0.001	0
S3	-2.5622	-0.0879	0.1115	-0.1204	0.1625	-0.1325	0.0578	-0.0118	0.0006
S4	-90	-0.078	0.2103	-0.4384	0.6397	-0.6153	0.3736	-0.1288	0.0189
S5	0	-0.1133	0.2975	-0.5447	0.7496	-0.7199	0.4525	-0.1642	0.0257
S6	4.6946	-0.0705	0.1434	-0.2144	0.1998	-0.0956	-0.0142	0.0399	-0.0137
S7	0	-0.0972	0.1221	-0.3303	0.5457	-0.6222	0.4555	-0.1995	0.0405
S8	0	-0.1596	0.2027	-0.3281	0.3412	-0.2472	0.1212	-0.0385	0.0064
S9	-18.27	-0.0564	-0.0069	0.0518	-0.0566	0.0228	-0.0011	-0.0019	0.0004
S10	-15.127	-0.0603	-0.0145	0.0594	-0.0601	0.0318	-0.0096	0.0015	-1E-04
S11	0	0.0027	-0.0398	0.025	-0.0137	0.005	-0.001	1E-04	-4E-06
S12	-1.1693	0.1224	-0.1006	0.0535	-0.0195	0.005	-0.0008	8E-05	-3E-06
S13	-4.4446	-0.097	-0.0137	0.0358	-0.0141	0.0028	-0.0003	2E-05	-5E-07
S14	-8.7431	-0.0906	0.0342	-0.009	0.0017	-0.0002	2E-05	-1E-06	3E-08

object-side surface and the image-side surface of the seventh lens **7005**.

The optical imaging system **5** further includes a stop, a filter **8005**, and an image sensor **9005**. The stop is disposed between the first lens **1005** and the second lens **2005** to adjust an amount of light incident on the image sensor **9005**. The filter **8005** is disposed between the seventh lens **7005** and the image sensor **9005** to block infrared rays. The image sensor **9005** forms an imaging plane on which an image of a subject is formed. Although not illustrated in FIG. **9**, the stop is disposed at distance of 0.3830 mm from the object-side surface of the first lens **1005** toward the imaging plane of the optical imaging system **5**. This distance is equal to TTL-SL and can be calculated from the values of TTL and SL for Example 5 listed in Table 57 that appears later in this application.

Table 9 below shows physical properties of the lenses and other elements of the optical imaging system of FIG. **9**, and Table 10 below shows aspherical surface coefficients of the lenses of FIG. **9**.

TABLE 9

Surface No.	Element	Radius of Curvature	Thickness/Distance	Index of Refraction	Abbe Number	Effective Aperture Radius
S1	First	2.1824	0.3329	1.546	56.114	1.380
S2	Lens	1.9439	0.0500			1.369
S3	(Stop)	1.6857	0.7322	1.546	56.114	1.335
S4	Second Lens	28.3727	0.0500			1.264
S5	Third	7.1536	0.2200	1.679	19.236	1.185
S6	Lens	2.9223	0.4264			1.050
S7	Fourth	46.9146	0.3121	1.646	23.528	1.112
S8	Lens	17.5860	0.2616			1.268
S9	Fifth	2.2655	0.2700	1.646	23.528	1.774
S10	Lens	2.3143	0.3731			1.839
S11	Sixth	8.5186	0.6078	1.546	56.114	2.160
S12	Lens	-1.9871	0.3782			2.308

Sixth Example

FIG. **11** is a view illustrating a sixth example of an optical imaging system, and FIG. **12** illustrates aberration curves of the optical imaging system of FIG. **11**.

An optical imaging system **6** includes a first lens **1006**, a second lens **2006**, a third lens **3006**, a fourth lens **4006**, a fifth lens **5006**, a sixth lens **6006**, and a seventh lens **7006**.

The first lens **1006** has a positive refractive power, and an object-side surface thereof is convex and an image-side surface thereof is concave. The second lens **2006** has a negative refractive power, and an object-side surface thereof is convex and an image-side surface thereof is concave. The third lens **3006** has a negative refractive power, and an object-side surface thereof is convex and an image-side surface thereof is concave. The fourth lens **4006** has a positive refractive power, and an object-side surface thereof is convex and an image-side surface thereof is concave. The fifth lens **5006** has a negative refractive power, and an object-side surface thereof is concave and an image-side surface thereof is convex. The sixth lens **6006** has a positive refractive power, and an object-side surface thereof is convex and an image-side surface thereof is convex. In addition, at least one inflection point is formed on either one or both of the object-side surface and the image-side surface of the sixth lens **6006**. The seventh lens **7006** has a negative refractive power, and an object-side surface thereof is concave and an image-side surface thereof is concave. In addition, one inflection point is formed on each of the object-side surface and the image-side surface of the seventh lens **7006**.

The optical imaging system **6** further includes a stop, a filter **8006**, and an image sensor **9006**. The stop is disposed between the first lens **1006** and the second lens **2006** to adjust an amount of light incident on the image sensor **9006**. The filter **8006** is disposed between the seventh lens **7006** and the image sensor **9006** to block infrared rays. The image

sensor **9006** forms an imaging plane on which an image of a subject is formed. Although not illustrated in FIG. **11**, the stop is disposed at a distance of 0.7312 mm from the object-side surface of the first lens **1006** toward the imaging plane of the optical imaging system **6**. This distance is equal to TTL-SL and can be calculated from the values of TTL and SL for Example 6 listed in Table 57 that appears later in this application.

Table 11 below shows physical properties of the lenses and other elements of the optical imaging system of FIG. **11**, and Table 12 below shows aspherical surface coefficients of the lenses of FIG. **11**.

TABLE 11

Surface No.	Element	Radius of Curvature	Thickness/Distance	Index of Refraction	Abbe Number	Effective Aperture Radius
S1	First	1.73233	0.73124	1.546	56.114	1.250
S2	Lens (Stop)	12.53699	0.07002			1.181
S3	Second	5.58930	0.20000	1.667	20.353	1.147
S4	Lens	2.57397	0.39715			1.100
S5	Third	8.06552	0.38474	1.546	56.114	1.128
S6	Lens	7.83668	0.19259			1.247
S7	Fourth	6.68716	0.24423	1.546	56.114	1.276
S8	Lens	30.32847	0.27130			1.374
S9	Fifth	-3.28742	0.24968	1.667	20.353	1.481
S10	Lens	-4.51593	0.13884			1.734
S11	Sixth	5.67988	0.51987	1.546	56.114	2.150
S12	Lens	-1.89003	0.31663			2.318
S13	Seventh	-3.93255	0.30000	1.546	56.114	2.640
S14	Lens	1.74183	0.19371			2.747
S15	Filter	Infinity	0.11000	1.518	64.166	3.146
S16		Infinity	0.77000			
S17	Imaging Plane	Infinity	0.01000	3.536		3.177

TABLE 12

	K	A	B	C	D	E	F	G	H	J
S1	-0.7464	0.0139	0.0344	-0.0749	0.1029	-0.0706	0.0173	0.0042	-0.0023	0
S2	36.669	-0.0823	0.195	-0.3067	0.3634	-0.323	0.1902	-0.0632	0.0086	0
S3	-1.3559	-0.1603	0.3305	-0.4059	0.3324	-0.1787	0.0673	-0.0166	0.0018	0
S4	-0.4109	-0.0907	0.1444	0.1155	-0.7969	1.5009	-1.4406	0.7219	-0.147	0
S5	0	-0.0739	0.0463	-0.1203	0.1165	-0.0578	-0.0089	0.0233	-0.0057	0
S6	0	-0.0932	0.0034	0.0521	-0.1827	0.2457	-0.2173	0.1126	-0.0241	0
S7	25.148	-0.1235	-0.1887	0.3763	-0.554	0.6731	-0.5796	0.2782	-0.0538	0
S8	-99	-9E-05	-0.3274	0.3588	-0.3195	0.3451	-0.2608	0.0995	-0.0144	0
S9	-70.894	0.0205	0.0483	-0.5284	0.7583	-0.4915	0.1636	-0.0271	0.0018	0
S10	2.2832	0.1759	-0.3448	0.2283	-0.0716	0.011	-0.0007	-4E-06	1E-06	0
S11	-99	0.1188	-0.2169	0.1675	-0.0871	0.0276	-0.0049	0.0005	-2E-05	0
S12	-3.3067	0.1644	-0.1849	0.1159	-0.049	0.0138	-0.0024	0.0002	-9E-06	0
S13	-2.4772	-0.1026	-0.0482	0.074	-0.0308	0.0067	-0.0008	6E-05	-2E-06	0
S14	-1.1028	-0.2935	0.2033	-0.1127	0.0457	-0.0129	0.0024	-0.0003	2E-05	-5E-07

Seventh Example

FIG. **13** is a view illustrating a seventh example of an optical imaging system, and FIG. **14** illustrates aberration curves of the optical imaging system of FIG. **13**.

An optical imaging system **7** includes a first lens **1007**, a second lens **2007**, a third lens **3007**, a fourth lens **4007**, a fifth lens **5007**, a sixth lens **6007**, and a seventh lens **7007**.

The first lens **1007** has a positive refractive power, and an object-side surface thereof is convex and an image-side surface thereof is concave. The second lens **2007** has a positive refractive power, and an object-side surface thereof is convex and an image-side surface thereof is convex. The third lens **3007** has a negative refractive power, and an

object-side surface thereof is convex and an image-side surface thereof is concave. The fourth lens **4007** has a negative refractive power, and an object-side surface thereof is convex and an image-side surface thereof is concave. The fifth lens **5007** has a positive refractive power, and an object-side surface thereof is convex and an image-side surface thereof is concave. The sixth lens **6007** has a negative refractive power, and an object-side surface thereof is convex and an image-side surface thereof is concave. In addition, at least one inflection point is formed on either one or both of the object-side surface and the image-side surface of the sixth lens **6007**. The seventh lens **7007** has a negative refractive power, and an object-side surface thereof is convex and an image-side surface thereof is concave. In addition, two inflection points are formed on the object-side surface of the seventh lens **7007**, and one inflection point is formed on the image-side surface of the seventh lens **7007**.

The optical imaging system **7** further includes a stop, a filter **8007**, and an image sensor **9007**. The stop is disposed between the second lens **2007** and the third lens **3007** to adjust an amount of light incident on the image sensor **9007**. The filter **8007** is disposed between the seventh lens **7007** and the image sensor **9007** to block infrared rays. The image sensor **9007** forms an imaging plane on which an image of a subject is formed. Although not illustrated in FIG. **13**, the stop is disposed at a distance of 1.1577 mm from the object-side surface of the first lens **1007** toward the imaging plane of the optical imaging system **7**. This distance is equal to TTL-SL and can be calculated from the values of TTL and SL for Example 7 listed in Table 57 that appears later in this application.

Table 13 below shows physical properties of the lenses and other elements of the optical imaging system of FIG. **13**, and Table 14 below shows aspherical surface coefficients of the lenses of FIG. **13**.

TABLE 13

Surface No.	Element	Radius of Curvature	Thickness/Distance	Index of Refraction	Abbe Number	Effective Aperture Radius
S1	First	2.141	0.481	1.546	56.114	1.450
S2	Lens	3.251	0.110			1.350
S3	Second	3.253	0.542	1.546	56.114	1.285
S4	Lens	-15.773	0.025			1.232
S5	(Stop)	8.425	0.230	1.679	19.236	1.157
S6	Third Lens	3.514	0.625			1.095
S7	Fourth	25.986	0.296	1.679	19.236	1.265
S8	Lens	15.894	0.230			1.452

TABLE 13-continued

Surface No.	Element	Radius of Curvature	Thickness/Distance	Index of Refraction	Abbe Number	Effective Aperture Radius
S9	Fifth	3.048	0.400	1.546	56.114	1.675
S10	Lens	3.616	0.290			2.092
S11	Sixth	3.762	0.400	1.679	19.236	2.153
S12	Lens	2.792	0.204			2.476
S13	Seventh	1.614	0.510	1.537	53.955	2.938
S14	Lens	1.326	0.196			3.102
S15	Filter	Infinity	0.110	1.518	64.197	3.420
S16		Infinity	0.639			3.450
S17	Imaging Plane	Infinity	0.011			3.730

is convex and an image-side surface thereof is concave. The fifth lens **5008** has a positive refractive power, and an object-side surface thereof is convex and an image-side surface thereof is concave. The sixth lens **6008** has a negative refractive power, and an object-side surface thereof is convex and an image-side surface thereof is concave. In addition, at least one inflection point is formed on either one or both of the object-side surface and the image-side surface of the sixth lens **6008**. The seventh lens **7008** has a negative refractive power, and an object-side surface thereof is convex and an image-side surface thereof is concave. In addition, one inflection point is formed on each of the object-side surface and the image-side surface of the seventh lens **7008**.

The optical imaging system **8** further includes a stop, a filter **8008**, and an image sensor **9008**. The stop is disposed

TABLE 14

	K	A	B	C	D	E	F	G	H	J
S1	-8.038	0.0707	-0.0797	0.0334	0.0072	-0.0491	0.0465	-0.0186	0.0032	-0.0002
S2	-20.594	-0.0019	-0.1494	0.2041	-0.2922	0.3755	-0.3085	0.1486	-0.0387	0.0042
S3	-0.0908	-0.0339	-0.0641	0.1368	-0.2821	0.4921	-0.4815	0.2605	-0.0746	0.0088
S4	-0.4822	-0.0436	0.1761	-0.3256	0.1999	0.1916	-0.4291	0.3203	-0.1141	0.0162
S5	-1.1841	-0.1073	0.2544	-0.4683	0.4991	-0.2863	0.0565	0.0325	-0.0229	0.0044
S6	0.8733	-0.0693	0.0357	0.2048	-0.8833	1.7328	-1.9742	1.3464	-0.5106	0.083
S7	-0.4999	-0.0314	0.0135	-0.2894	0.9716	-1.7181	1.7923	-1.1152	0.3837	-0.0563
S8	-1E-06	-0.0273	-0.1177	0.212	-0.2544	0.2157	-0.1264	0.0469	-0.0093	0.0007
S9	-41.843	0.1624	-0.3487	0.4016	-0.3105	0.1396	-0.027	-0.0038	0.0026	-0.0003
S10	-5.1424	0.0397	-0.1364	0.1569	-0.1229	0.0633	-0.0212	0.0044	-0.0005	3E-05
S11	-2.1666	0.0356	-0.1809	0.1985	-0.1438	0.0641	-0.0173	0.0028	-0.0002	9E-06
S12	-0.0207	-0.1043	0.0239	-0.0063	-0.0007	0.0007	-3E-06	-4E-05	7E-06	-4E-07
S13	-0.7948	-0.4128	0.1863	-0.0516	0.0101	-0.0015	0.0002	-1E-05	6E-07	-1E-08
S14	-1.3226	-0.3105	0.1713	-0.0712	0.0213	-0.0043	0.0006	-5E-05	2E-06	-5E-08

Eighth Example

FIG. **15** is a view illustrating an eighth example of an optical imaging system, and FIG. **16** illustrates aberration curves of the optical imaging system of FIG. **15**.

An optical imaging system **8** includes a first lens **1008**, a second lens **2008**, a third lens **3008**, a fourth lens **4008**, a fifth lens **5008**, a sixth lens **6008**, and a seventh lens **7008**.

The first lens **1008** has a positive refractive power, and an object-side surface thereof is convex and an image-side surface thereof is concave. The second lens **2008** has a positive refractive power, and an object-side surface thereof is convex and an image-side surface thereof is concave. The third lens **3008** has a negative refractive power, and an object-side surface thereof is convex and an image-side surface thereof is concave. The fourth lens **4008** has a positive refractive power, and an object-side surface thereof

between the second lens **2008** and the third lens **3008** to adjust an amount of light incident on the image sensor **9008**.

The filter **8008** is disposed between the seventh lens **7008** and the image sensor **9008** to block infrared rays. The image sensor **9008** forms an imaging plane on which an image of a subject is formed. Although not illustrated in FIG. **15**, the stop is disposed at a distance of 1.0800 mm from the object-side surface of the first lens **1008** toward the imaging plane of the optical imaging system **8**. This distance is equal to TTL-SL and can be calculated from the values of TTL and SL for Example 8 listed in Table 57 that appears later in this application.

Table 15 below shows physical properties of the lenses and other elements of the optical imaging system of FIG. **15**, and Table 16 below shows aspherical surface coefficients of the lenses of FIG. **15**.

TABLE 15

Surface No.	Element	Radius of Curvature	Thickness/Distance	Index of Refraction	Abbe Number	Effective Aperture Radius
S1	First	2.1367244	0.486053	1.546	56.114	1.360
S2	Lens	2.8897668	0.087572			1.331
S3	Second	3.1970288	0.481363	1.546	56.114	1.301
S4	Lens	109.26781	0.025			1.264
S5	(Stop)	8.2164833	0.333222	1.679	19.236	1.218
S6	Third Lens	3.6430265	0.428709			1.229
S7	Fourth	5.149363	0.374385	1.546	56.114	1.353
S8	Lens	7.9835412	0.393693			1.392
S9	Fifth	3.8134324	0.4	1.546	56.114	1.576
S10	Lens	4.8504303	0.288816			2.010
S11	Sixth	3.8912859	0.4	1.546	56.114	1.916
S12	Lens	3.0824847	0.229858			2.371

TABLE 15-continued

Surface No.	Element	Radius of Curvature	Thickness/ Distance	Index of Refraction	Abbe Number	Effective Aperture Radius
S13	Seventh	1.6011178	0.493312	1.546	56.114	2.526
S14	Lens	1.2142472	0.218016			2.787
S15	Filter	Infinity	0.21	1.518	64.197	3.238
S16		Infinity	0.634932			3.316
S17	Imaging Plane	Infinity	0.015			3.728

TABLE 16

	K	A	B	C	D	E	F	G	H	J
S1	-1	-0.0136	0.0247	-0.0811	0.0925	-0.0456	-0.0139	0.0275	-0.0118	0.0017
S2	-13.222	0.0184	-0.091	-0.0856	0.3055	-0.3421	0.2293	-0.0976	0.0238	-0.0025
S3	-1.2237	-0.0255	0.013	-0.2994	0.6492	-0.662	0.4089	-0.1567	0.0332	-0.0029
S4	-7.0515	-0.018	0.0942	-0.4684	1.1965	-1.7785	1.5984	-0.8543	0.2492	-0.0305
S5	8.9885	-0.0606	0.147	-0.5476	1.4146	-2.2793	2.2356	-1.2976	0.4106	-0.0546
S6	1.6556	-0.053	0.0664	-0.1724	0.4882	-0.9461	1.1092	-0.7563	0.2786	-0.0429
S7	-4.3409	-0.0524	-0.0067	0.1244	-0.3711	0.5503	-0.4701	0.228	-0.0561	0.0052
S8	5.8589	-0.0866	0.13	-0.4361	0.9157	-1.2163	1.0086	-0.506	0.1405	-0.0165
S9	-43.521	0.0853	-0.1755	0.2257	-0.2234	0.1539	-0.0732	0.0221	-0.0038	0.0003
S10	-3.1047	0.0435	-0.1427	0.1592	-0.1109	0.05	-0.0153	0.0031	-0.0004	2E-05
S11	-16.199	0.1264	-0.2435	0.2571	-0.2182	0.1176	-0.0381	0.0072	-0.0007	3E-05
S12	0.1758	-0.0767	0.0734	-0.0745	0.0337	-0.008	0.0011	-7E-05	2E-06	-1E-08
S13	-0.8173	-0.4272	0.2044	-0.0489	0.002	0.0021	-0.0006	8E-05	-6E-06	2E-07
S14	-1.397	-0.3515	0.2336	-0.1198	0.0447	-0.0113	0.0019	-0.0002	1E-05	-3E-07

Ninth Example

FIG. 17 is a view illustrating a ninth example of an optical imaging system, and FIG. 18 illustrates aberration curves of the optical imaging system of FIG. 17.

An optical imaging system 9 includes a first lens 1009, a second lens 2009, a third lens 3009, a fourth lens 4009, a fifth lens 5009, a sixth lens 6009, and a seventh lens 7009.

The first lens 1009 has a positive refractive power, and an object-side surface thereof is convex and an image-side surface thereof is concave. The second lens 2009 has a positive refractive power, and an object-side surface thereof is convex and an image-side surface thereof is concave. The third lens 3009 has a negative refractive power, and an object-side surface thereof is convex and an image-side surface thereof is concave. The fourth lens 4009 has a positive refractive power, and an object-side surface thereof is convex and an image-side surface thereof is concave. The fifth lens 5009 has a negative refractive power, and an object-side surface thereof is convex and an image-side surface thereof is concave. The sixth lens 6009 has a positive refractive power, and an object-side surface thereof is convex and an image-side surface thereof is concave. In addition, at least one inflection point is formed on either one or

both of the object-side surface and the image-side surface of the sixth lens 6009. The seventh lens 7009 has a negative refractive power, and an object-side surface thereof is convex and an image-side surface thereof is concave. In addition, two inflection points are formed on the object-side surface of the seventh lens 7009, and one inflection point is formed on the image-side surface of the seventh lens 7009.

The optical imaging system 9 further includes a stop, a filter 8009, and an image sensor 9009. The stop is disposed between the second lens 2009 and the third lens 3009 to adjust an amount of light incident on the image sensor 9009. The filter 8009 is disposed between the seventh lens 7009 and the image sensor 9009 to block infrared rays. The image sensor 9009 forms an imaging plane on which an image of a subject is formed. Although not illustrated in FIG. 17, the stop is disposed at a distance of 1.0767 mm from the object-side surface of the first lens 1009 toward the imaging plane of the optical imaging system 9. This distance is equal to TTL-SL and can be calculated from the values of TTL and SL for Example 9 listed in Table 57 that appears later in this application.

Table 17 below shows physical properties of the lenses and other elements of the optical imaging system of FIG. 17, and Table 18 below shows aspherical surface coefficients of the lenses of FIG. 17.

TABLE 17

Surface No.	Element	Radius of Curvature	Thickness/ Distance	Index of Refraction	Abbe Number	Effective Aperture Radius
S1	First	2.1183051	0.467301	1.546	56.114	1.360
S2	Lens	2.7465072	0.088291			1.343
S3	Second	2.805316	0.495083	1.546	56.114	1.313
S4	Lens	29.972181	0.026058			1.266
S5	(Stop)	5.6204988	0.273577	1.679	19.236	1.212
S6	Third	2.8589333	0.365293			1.199

TABLE 17-continued

Surface No.	Element	Radius of Curvature	Thickness/Distance	Index of Refraction	Abbe Number	Effective Aperture Radius
	Lens					
S7	Fourth	6.0851103	0.415715	1.546	56.114	1.285
S8	Lens	19.143835	0.530007			1.350
S9	Fifth	5.7830909	0.4	1.679	19.236	1.600
S10	Lens	4.5644102	0.188701			2.100
S11	Sixth	2.807724	0.444625	1.546	56.114	1.903
S12	Lens	3.201154	0.276382			2.470
S13	Seventh	1.6500839	0.458527	1.546	56.114	2.646
S14	Lens	1.1944054	0.21044			2.806
S15	Filter	Infinity	0.21	1.518	64.197	3.241
S16		Infinity	0.643292			3.319
S17	Imaging Plane	Infinity	0.006708			3.729

TABLE 18

	K	A	B	C	D	E	F	G	H	J
S1	-1	-0.0103	0.0078	-0.0588	0.0925	-0.0904	0.0486	-0.0119	0.0004	0.0002
S2	-13.05	0.0258	-0.1274	0.035	0.0617	-0.0405	0.0003	0.0049	-0.0007	-0.0001
S3	-1.2154	-0.0166	-0.0602	-0.0171	0.0625	0.0481	-0.1007	0.0511	-0.0092	0.0002
S4	-7.0515	-0.047	0.2681	-0.8387	1.4546	-1.5426	1.0264	-0.4201	0.0974	-0.0099
S5	8.8287	-0.0982	0.3106	-0.8268	1.4538	-1.7174	1.3464	-0.6715	0.1944	-0.025
S6	1.7217	-0.0695	0.0939	-0.1196	0.1421	-0.2108	0.2773	-0.2257	0.0997	-0.0182
S7	-1.4309	-0.0448	-0.0056	0.0299	-0.0484	-0.0039	0.0856	-0.1013	0.0511	-0.0095
S8	5.8592	-0.0455	-0.0133	0.0337	-0.0729	0.0922	-0.0766	0.0411	-0.0128	0.0018
S9	-43.521	0.0008	-0.0239	0.0222	-0.0173	0.0051	-0.0002	-0.0003	5E-05	5E-06
S10	-11.855	-0.0163	-0.0578	0.0832	-0.067	0.0334	-0.0109	0.0023	-0.0003	1E-05
S11	-16.199	0.1024	-0.1959	0.1931	-0.1564	0.0797	-0.0243	0.0044	-0.0004	2E-05
S12	0.1668	-0.0913	0.11	-0.1075	0.0537	-0.0157	0.0029	-0.0003	2E-05	-6E-07
S13	-0.8022	-0.4375	0.2118	-0.049	0.0016	0.0021	-0.0006	7E-05	-4E-06	1E-07
S14	-1.407	-0.3709	0.2499	-0.1268	0.0461	-0.0114	0.0018	-0.0002	1E-05	-3E-07

Tenth Example

FIG. 19 is a view illustrating a tenth example of an optical imaging system, and FIG. 20 illustrates aberration curves of the optical imaging system of FIG. 19.

An optical imaging system 10 includes a first lens 1010, a second lens 2010, a third lens 3010, a fourth lens 4010, a fifth lens 5010, a sixth lens 6010, and a seventh lens 7010.

The first lens 1010 has a positive refractive power, and an object-side surface thereof is convex and an image-side surface thereof is concave. The second lens 2010 has a positive refractive power, and an object-side surface thereof is convex and an image-side surface thereof is concave. The third lens 3010 has a negative refractive power, and an object-side surface thereof is convex and an image-side surface thereof is concave. The fourth lens 4010 has a positive refractive power, and an object-side surface thereof is convex and an image-side surface thereof is concave. The fifth lens 5010 has a positive refractive power, and an object-side surface thereof is convex and an image-side surface thereof is concave. The sixth lens 6010 has a negative refractive power, and an object-side surface thereof is convex and an image-side surface thereof is concave. In addition, at least one inflection point is formed on either one or both of the object-side surface and the image-side surface of the sixth lens 6010. The seventh lens 7010 has a negative

refractive power, and an object-side surface thereof is convex and an image-side surface thereof is concave. In addition, one inflection point is formed on each of the object-side surface and the image-side surface of the seventh lens 7010.

The optical imaging system 10 further includes a stop, a filter 8010, and an image sensor 9010. The stop is disposed between the second lens 2010 and the third lens 3010 to adjust an amount of light incident on the image sensor 9010. The filter 8010 is disposed between the seventh lens 7010 and the image sensor 9010 to block infrared rays. The image sensor 9010 forms an imaging plane on which an image of a subject is formed. Although not illustrated in FIG. 19, the stop is disposed at a distance of 1.1782 mm from the object-side surface of the first lens 1010 toward the imaging plane of the optical imaging system 10. This distance is equal to TTL-SL and can be calculated from the values of TTL and SL for Example 10 listed in Table 57 that appears later in this application.

Table 19 below shows physical properties of the lenses and other elements of the optical imaging system of FIG. 19, and Table 20 below shows aspherical surface coefficients of the lenses of FIG. 19.

TABLE 19

Surface No.	Element	Radius of Curvature	Thickness/Distance	Index of Refraction	Abbe Number	Effective Aperture Radius
S1	First	2.3673866	0.52496	1.546	56.114	1.449
S2	Lens	3.194732	0.05968			1.420
S3	Second	3.4203396	0.567044	1.546	56.114	1.396
S4	Lens	70.973752	0.026546			1.328
S5	(Stop)	7.7783333	0.350469	1.679	19.236	1.286
S6	Third	3.8162291	0.409426			1.313
S7	Lens					
S7	Fourth	5.5916886	0.369187	1.546	56.114	1.426
S8	Lens	7.9939167	0.39653			1.495
S9	Fifth	4.1003359	0.426003	1.546	56.114	1.707
S10	Lens	5.3728393	0.303377			1.986
S11	Sixth	4.360929	0.424063	1.679	19.236	1.999
S12	Lens	3.5684544	0.223456			2.401
S13	Seventh	1.7878712	0.541352	1.546	56.114	2.495
S14	Lens	1.3975055	0.200463			2.837
S15	Filter	Infinity	0.21	1.518	64.197	3.186
S16		Infinity	0.831011			3.256
S17	Imaging Plane	Infinity	0.001244			3.785

TABLE 20

	K	A	B	C	D	E	F	G	H	J
S1	-1	-0.006	-0.0037	-0.012	0.012	0.0136	-0.0351	0.0267	-0.009	0.0011
S2	-13.101	0.0148	-0.0546	-0.0452	0.1269	-0.1111	0.056	-0.0175	0.0031	-0.0002
S3	-1.2472	-0.0205	0.0163	-0.1488	0.2518	-0.2171	0.1218	-0.045	0.0097	-0.0009
S4	-7.0515	-0.0205	0.1049	-0.3805	0.7515	-0.8792	0.6257	-0.2656	0.0617	-0.006
S5	8.9156	-0.0324	-0.0045	0.0638	-0.1003	0.0567	0.0072	-0.0234	0.0103	-0.0015
S6	1.6638	-0.0267	-0.1125	0.5983	-1.3543	1.7261	-1.3193	0.5999	-0.1494	0.0157
S7	-4.619	-0.0378	-0.0049	0.0644	-0.1511	0.1787	-0.1225	0.0479	-0.0096	0.0007
S8	5.6116	-0.0667	0.143	-0.4869	0.9313	-1.0571	0.7241	-0.2938	0.0651	-0.006
S9	-44.124	0.0571	-0.0758	0.0454	-0.0145	0.0009	5E-05	0.0002	-8E-05	9E-06
S10	-4.9813	0.0353	-0.0999	0.1024	-0.0647	0.026	-0.0068	0.0011	-0.0001	4E-06
S11	-15.42	0.099	-0.1649	0.1482	-0.1003	0.0426	-0.0109	0.0016	-0.0001	5E-06
S12	0.1791	-0.0585	0.0531	-0.0451	0.0177	-0.0038	0.0005	-4E-05	2E-06	-3E-08
S13	-0.825	-0.303	0.1166	-0.0228	0.0011	0.0005	-0.0001	1E-05	-7E-07	1E-08
S14	-1.3872	-0.2937	0.1877	-0.0863	0.0269	-0.0055	0.0007	-6E-05	3E-06	-5E-08

Eleventh Example

FIG. 21 is a view illustrating an eleventh example of an optical imaging system, and FIG. 22 illustrates aberration curves of the optical imaging system of FIG. 21.

An optical imaging system 11 includes a first lens 1011, a second lens 2011, a third lens 3011, a fourth lens 4011, a fifth lens 5011, a sixth lens 6011, and a seventh lens 7011.

The first lens 1011 has a positive refractive power, and an object-side surface thereof is convex and an image-side surface thereof is concave. The second lens 2011 has a positive refractive power, and an object-side surface thereof is convex and an image-side surface thereof is concave. The third lens 3011 has a negative refractive power, and an object-side surface thereof is convex and an image-side surface thereof is concave. The fourth lens 4011 has a positive refractive power, and an object-side surface thereof is convex and an image-side surface thereof is concave. The fifth lens 5011 has a positive refractive power, and an object-side surface thereof is convex and an image-side surface thereof is concave. The sixth lens 6011 has a negative refractive power, and an object-side surface thereof is convex and an image-side surface thereof is concave. In addition, at least one inflection point is formed on either one or both of the object-side surface and the image-side surface

of the sixth lens 6011. The seventh lens 7011 has a negative refractive power, and an object-side surface thereof is convex and an image-side surface thereof is concave. In addition, two inflection points are formed on the object-side surface of the seventh lens 7011, and one inflection point is formed on the image-side surface of the seventh lens 7011.

The optical imaging system 11 further includes a stop, a filter 8011, and an image sensor 9011. The stop is disposed between the second lens 2011 and the third lens 3011 to adjust an amount of light incident on the image sensor 9011. The filter 8011 is disposed between the seventh lens 7011 and the image sensor 9011 to block infrared rays. The image sensor 9011 forms an imaging plane on which an image of a subject is formed. Although not illustrated in FIG. 21, the stop is disposed at a distance of 1.2296 mm from the object-side surface of the first lens 1011 toward the imaging plane of the optical imaging system 11. This distance is equal to TTL-SL and can be calculated from the values of TTL and SL for Example 11 listed in Table 57 that appears later in this application.

Table 21 below shows physical properties of the lenses and other elements of the optical imaging system of FIG. 21, and Table 22 below shows aspherical surface coefficients of the lenses of FIG. 21.

TABLE 21

Surface No.	Element	Radius of Curvature	Thickness/Distance	Index of Refraction	Abbe Number	Effective Aperture Radius
S1	First	2.0759937	0.461868	1.546	56.114	1.450
S2	Lens	2.4626776	0.142767			1.423
S3	Second	2.5138054	0.6	1.546	56.114	1.392
S4	Lens	29.011046	0.025			1.339
S5	(Stop)	8.6847676	0.23	1.679	19.236	1.295
S6	Third Lens	3.5580278	0.403456			1.273
S7	Fourth	4.7911408	0.352214	1.546	56.114	1.378
S8	Lens	7.0752276	0.349153			1.451
S9	Fifth	4.2812245	0.35	1.546	56.114	1.632
S10	Lens	6.1353451	0.360979			2.012
S11	Sixth	4.4147672	0.43	1.679	19.236	2.013
S12	Lens	3.9218806	0.295711			2.303
S13	Seventh	1.740331	0.438887	1.546	56.114	2.548
S14	Lens	1.2235575	0.199966			2.831
S15	Filter	Infinity	0.21	1.518	64.197	3.299
S16		Infinity	0.637453			3.370
S17	Imaging Plane	Infinity	0.012547			3.731

TABLE 22

	K	A	B	C	D	E	F	G	H	J
S1	-1	-0.0092	0.003	-0.0414	0.0636	-0.0562	0.026	-0.0049	-0.0002	0.0001
S2	-11.557	0.0601	-0.1844	0.2568	-0.3524	0.3604	-0.23	0.0871	-0.018	0.0016
S3	-0.8307	-0.0024	-0.0852	0.1656	-0.3174	0.3977	-0.2764	0.1063	-0.0212	0.0016
S4	33.131	-0.027	0.1754	-0.4193	0.3931	-0.0382	-0.2294	0.1977	-0.0691	0.0091
S5	14.848	-0.09	0.2473	-0.422	0.2881	0.1413	-0.4099	0.3093	-0.1063	0.0142
S6	2.0645	-0.0757	0.0883	0.0177	-0.3102	0.6013	-0.6108	0.357	-0.1119	0.0146
S7	-10.536	-0.0399	-0.0508	0.2144	-0.4431	0.5288	-0.3825	0.1604	-0.034	0.0025
S8	1.3378	-0.0489	-0.0512	0.1032	-0.1013	0.0149	0.0599	-0.0576	0.0222	-0.0032
S9	-44.096	0.0784	-0.1355	0.1317	-0.0913	0.0374	-0.0091	0.001	4E-05	-1E-05
S10	-6.651	0.049	-0.1189	0.1277	-0.0852	0.0342	-0.0083	0.0012	-1E-04	3E-06
S11	-13.816	0.0584	-0.1268	0.1161	-0.0837	0.0379	-0.0102	0.0016	-0.0001	5E-06
S12	1.0596	-0.0574	0.0273	-0.0248	0.0087	-0.0016	0.0002	-9E-06	2E-07	-5E-10
S13	-0.8717	-0.4042	0.1652	-0.0262	-0.0057	0.0037	-0.0008	9E-05	-6E-06	1E-07
S14	-1.3714	-0.3652	0.2385	-0.1205	0.0439	-0.0107	0.0017	-0.0002	9E-06	-2E-07

Twelfth Example

FIG. 23 is a view illustrating a twelfth example of an optical imaging system, and FIG. 24 illustrates aberration curves of the optical imaging system of FIG. 23.

An optical imaging system 12 includes a first lens 1012, a second lens 2012, a third lens 3012, a fourth lens 4012, a fifth lens 5012, a sixth lens 6012, and a seventh lens 7012.

The first lens 1012 has a positive refractive power, and an object-side surface thereof is convex and an image-side surface thereof is concave. The second lens 2012 has a positive refractive power, and an object-side surface thereof is convex and an image-side surface thereof is concave. The third lens 3012 has a negative refractive power, and an object-side surface thereof is convex and an image-side surface thereof is concave. The fourth lens 4012 has a positive refractive power, and an object-side surface thereof is convex and an image-side surface thereof is concave. The fifth lens 5012 has a positive refractive power, and an object-side surface thereof is convex and an image-side surface thereof is concave. The sixth lens 6012 has a negative refractive power, and an object-side surface thereof is convex and an image-side surface thereof is concave. In addition, at least one inflection point is formed on either one or both of the object-side surface and the image-side surface

of the sixth lens 6012. The seventh lens 7012 has a negative refractive power, and an object-side surface thereof is convex and an image-side surface thereof is concave. In addition, two inflection points are formed on the object-side surface of the seventh lens 7012, and one inflection point is formed on the image-side surface of the seventh lens 7012.

The optical imaging system 12 further includes a stop, a filter 8012, and an image sensor 9012. The stop is disposed between the second lens 2012 and the third lens 3012 to adjust an amount of light incident on the image sensor 9012. The filter 8012 is disposed between the seventh lens 7012 and the image sensor 9012 to block infrared rays. The image sensor 9012 forms an imaging plane on which an image of a subject is formed. Although not illustrated in FIG. 23, the stop is disposed at a distance of 1.1793 mm from the object-side surface of the first lens 1012 toward the imaging plane of the optical imaging system 12. This distance is equal to TTL-SL and can be calculated from the values of TTL and SL for Example 12 listed in Table 57 that appears later in this application.

Table 23 below shows physical properties of the lenses and other elements of the optical imaging system of FIG. 23, and Table 24 below shows aspherical surface coefficients of the lenses of FIG. 23.

TABLE 23

Surface No.	Element	Radius of Curvature	Thickness/ Distance	Index of Refraction	Abbe Number	Effective Aperture Radius
S1	First	2.3878602	0.35	1.546	56.114	1.470
S2	Lens	2.621324	0.10425			1.439
S3	Second	2.5382264	0.7	1.546	56.114	1.405
S4	Lens	36.207255	0.025			1.322
S5	(Stop)	7.7960711	0.23	1.679	19.236	1.287
S6	Third Lens	3.4912075	0.396134			1.325
S7	Fourth	5.4331241	0.505386	1.546	56.114	1.461
S8	Lens	9.3905062	0.443673			1.563
S9	Fifth	4.6788866	0.484222	1.546	56.114	1.772
S10	Lens	9.5732832	0.475792			2.209
S11	Sixth	7.1894204	0.475353	1.679	19.236	2.238
S12	Lens	3.8397107	0.215445			2.557
S13	Seventh	1.8137383	0.559854	1.546	56.114	3.026
S14	Lens	1.3872365	0.230078			3.262
S15	Filter	Infinity	0.11	1.518	64.197	3.724
S16		Infinity	0.635			3.763
S17	Imaging Plane	Infinity	0.015			4.160

TABLE 24

	K	A	B	C	D	E	F	G	H	J
S1	-0.9977	-0.0046	-0.0139	-0.024	0.0712	-0.0925	0.0658	-0.0257	0.0051	-0.0004
S2	-10.008	0.0879	-0.2624	0.4378	-0.5581	0.4751	-0.2476	0.0753	-0.0122	0.0008
S3	-0.5121	-0.0082	0.0297	-0.2049	0.402	-0.4509	0.3219	-0.1392	0.0325	-0.0031
S4	42.587	-0.0077	-0.0816	0.5107	-1.169	1.3206	-0.8193	0.2839	-0.0514	0.0038
S5	14.891	-0.0724	0.0409	0.4245	-1.2505	1.5731	-1.0799	0.4229	-0.0892	0.0079
S6	1.8054	-0.0886	0.1906	-0.2777	0.2837	-0.2167	0.1131	-0.0327	0.0033	0.0002
S7	-10.152	0.028	-0.4038	1.2639	-2.2626	2.4845	-1.6998	0.7029	-0.16	0.0153
S8	1.7534	-0.0643	0.1117	-0.3935	0.7438	-0.8306	0.565	-0.2306	0.0519	-0.005
S9	-44.62	0.0891	-0.1333	0.115	-0.0807	0.043	-0.017	0.0044	-0.0006	4E-05
S10	-4.9001	0.0976	-0.137	0.0999	-0.0465	0.0132	-0.0022	0.0002	-1E-05	2E-07
S11	-13.159	0.0954	-0.1535	0.1202	-0.0703	0.0264	-0.006	0.0008	-6E-05	2E-06
S12	0.7792	-0.0211	-0.0288	0.0188	-0.0093	0.003	-0.0006	6E-05	-4E-06	9E-08
S13	-0.8786	-0.3003	0.0918	-0.0015	-0.0073	0.0023	-0.0004	3E-05	-1E-06	3E-08
S14	-1.3086	-0.2504	0.1203	-0.0427	0.0114	-0.0021	0.0003	-2E-05	9E-07	-2E-08

Thirteenth Example

FIG. 25 is a view illustrating a thirteenth example of an optical imaging system, and FIG. 26 illustrates aberration curves of the optical imaging system of FIG. 25.

An optical imaging system 13 includes a first lens 1013, a second lens 2013, a third lens 3013, a fourth lens 4013, a fifth lens 5013, a sixth lens 6013, and a seventh lens 7013.

The first lens 1013 has a positive refractive power, and an object-side surface thereof is convex and an image-side surface thereof is concave. The second lens 2013 has a positive refractive power, and an object-side surface thereof is convex and an image-side surface thereof is concave. The third lens 3013 has a negative refractive power, and an object-side surface thereof is convex and an image-side surface thereof is concave. The fourth lens 4013 has a positive refractive power, and an object-side surface thereof is convex and an image-side surface thereof is concave. The fifth lens 5013 has a positive refractive power, and an object-side surface thereof is convex and an image-side surface thereof is concave. The sixth lens 6013 has a negative refractive power, and an object-side surface thereof is convex and an image-side surface thereof is concave. In addition, at least one inflection point is formed on either one or both of the object-side surface and the image-side surface

of the sixth lens 6013. The seventh lens 7013 has a negative refractive power, and an object-side surface thereof is convex and an image-side surface thereof is concave. In addition, two inflection points are formed on the object-side surface of the seventh lens 7013, and one inflection point is formed on the image-side surface of the seventh lens 7013.

The optical imaging system 13 further includes a stop, a filter 8013, and an image sensor 9013. The stop is disposed between the second lens 2013 and the third lens 3013 to adjust an amount of light incident on the image sensor 9013. The filter 8013 is disposed between the seventh lens 7013 and the image sensor 9013 to block infrared rays. The image sensor 9013 forms an imaging plane on which an image of a subject is formed. Although not illustrated in FIG. 25, the stop is disposed at a distance of 1.2052 mm from the object-side surface of the first lens 1013 toward the imaging plane of the optical imaging system 13. This distance is equal to TTL-SL and can be calculated from the values of TTL and SL for Example 13 listed in Table 57 that appears later in this application.

Table 25 below shows physical properties of the lenses and other elements of the optical imaging system of FIG. 25, and Table 26 below shows aspherical surface coefficients of the lenses of FIG. 25.

TABLE 25

Surface No.	Element	Radius of Curvature	Thickness/Distance	Index of Refraction	Abbe Number	Effective Aperture Radius
S1	First	2.3421801	0.35	1.546	56.114	1.570
S2	Lens	2.4608227	0.130273			1.582
S3	Second	2.309069	0.7	1.546	56.114	1.578
S4	Lens	38.833557	0.025			1.553
S5	(Stop)	7.6526629	0.25298	1.679	19.236	1.474
S6	Third	3.3272174	0.504716			1.325
S7	Lens					
S7	Fourth	5.6743754	0.346649	1.679	19.236	1.461
S8	Lens	6.5811075	0.40646			1.563
S9	Fifth	4.7925509	0.35	1.546	56.114	1.772
S10	Lens	10.114446	0.527822			2.209
S11	Sixth	6.1622692	0.43	1.679	19.236	2.238
S12	Lens	3.9299512	0.26246			2.557
S13	Seventh	1.9665801	0.564397	1.546	56.114	3.026
S14	Lens	1.490457	0.226843			3.262
S15	Filter	Infinity	0.11	1.518	64.197	3.641
S16		Infinity	0.797349			3.681
S17	Imaging Plane	Infinity	0.015			4.171

TABLE 26

	K	A	B	C	D	E	F	G	H	J
S1	-1	-0.0146	0.01	-0.0522	0.0643	-0.0468	0.0217	-0.0061	0.0009	-6E-05
S2	-9.9316	0.0529	-0.0805	0.0187	0.0015	0.0183	-0.0206	0.0089	-0.0018	0.0001
S3	-0.3035	-0.0312	0.1094	-0.2703	0.3068	-0.1783	0.0505	-0.0026	-0.0019	0.0003
S4	42.587	-0.14	0.5905	-1.3419	1.845	-1.6056	0.8858	-0.299	0.0561	-0.0045
S5	14.878	-0.1698	0.5798	-1.2212	1.6455	-1.4398	0.807	-0.2778	0.0533	-0.0044
S6	2.4782	-0.0974	0.3302	-0.8477	1.4713	-1.6606	1.1916	-0.5238	0.1288	-0.0136
S7	-10.89	-0.0126	-0.1352	0.3555	-0.5088	0.426	-0.2043	0.0479	-0.0019	-0.0008
S8	2.4559	-0.0438	-0.0219	-0.0159	0.1351	-0.2288	0.1952	-0.0929	0.0235	-0.0025
S9	-44.519	0.0902	-0.1408	0.1256	-0.0754	0.0253	-0.0032	-0.0008	0.0003	-3E-05
S10	2.7864	0.0708	-0.1198	0.1033	-0.057	0.0193	-0.004	0.0005	-3E-05	9E-07
S11	-17.823	0.0653	-0.1084	0.075	-0.0394	0.0131	-0.0026	0.0003	-2E-05	5E-07
S12	0.5903	-0.0273	-0.0096	0.0039	-0.0025	0.001	-0.0002	2E-05	-1E-06	3E-08
S13	-0.8439	-0.2851	0.1057	-0.0237	0.0034	-0.0003	5E-07	2E-06	-1E-07	4E-09
S14	-1.3672	-0.238	0.119	-0.0473	0.0138	-0.0027	0.0003	-3E-05	1E-06	-2E-08

Fourteenth Example

FIG. 27 is a view illustrating a fourteenth example of an optical imaging system, and FIG. 28 illustrates aberration curves of the optical imaging system of FIG. 27.

An optical imaging system 14 includes a first lens 1014, a second lens 2014, a third lens 3014, a fourth lens 4014, a fifth lens 5014, a sixth lens 6014, and a seventh lens 7014.

The first lens 1014 has a positive refractive power, and an object-side surface thereof is convex and an image-side surface thereof is concave. The second lens 2014 has a negative refractive power, and an object-side surface thereof is convex and an image-side surface thereof is concave. The third lens 3014 has a positive refractive power, and an object-side surface thereof is convex and an image-side surface thereof is concave. The fourth lens 4014 has a positive refractive power, and an object-side surface thereof is convex and an image-side surface thereof is concave. The fifth lens 5014 has a negative refractive power, and an object-side surface thereof is concave and an image-side surface thereof is convex. The sixth lens 6014 has a negative refractive power, and an object-side surface thereof is convex and an image-side surface thereof is concave. In addition, at least one inflection point is formed on either one or both of the object-side surface and the image-side surface of

the sixth lens 6014. The seventh lens 7014 has a negative refractive power, and an object-side surface thereof is convex and an image-side surface thereof is concave. In addition, one inflection point is formed on each of the object-side surface and the image-side surface of the seventh lens 7014.

The optical imaging system 14 further includes a stop, a filter 8014, and an image sensor 9014. The stop is disposed in front of the first lens 1014 to adjust an amount of light incident on the image sensor 9014. The filter 8014 is disposed between the seventh lens 7014 and the image sensor 9014 to block infrared rays. The image sensor 9014 forms an imaging plane on which an image of a subject is formed. Although not illustrated in FIG. 27, the stop is disposed at a distance of 0.2500 mm from the object-side surface of the first lens 1014 toward the imaging plane of the optical imaging system 14. This distance is equal to TTL-SL and can be calculated from the values of TTL and SL for Example 14 listed in Table 57 that appears later in this application.

Table 27 below shows physical properties of the lenses and other elements of the optical imaging system of FIG. 27, and Table 28 below shows aspherical surface coefficients of the lenses of FIG. 27.

TABLE 27

Surface No.	Element	Radius of Curvature	Thickness/Distance	Index of Refraction	Abbe Number	Effective Aperture Radius
S1	(Stop)	1.7211	0.6349	1.544	56.114	1.100
S2	First Lens	11.4571	0.1212			1.071
S3	Second Lens	119.1721	0.2033	1.661	20.353	1.057
S4	Lens	4.4758	0.0843			1.043
S5	Third Lens	4.5258	0.3109	1.544	56.114	1.051
S6	Lens	20.6082	0.2158			1.015
S7	Fourth Lens	13.2152	0.2369	1.544	56.114	1.019
S8	Lens	16.2733	0.2103			1.070
S9	Fifth Lens	-6.5732	0.4119	1.651	21.494	1.076
S10	Lens	-10.4553	0.3710			1.320
S11	Sixth Lens	3.4779	0.6318	1.544	56.114	1.556
S12	Lens	3.1994	0.2672			2.337
S13	Seventh Lens	2.8804	0.5060	1.544	56.114	2.489
S14	Lens	1.7054	0.1384			2.666
S15	Filter	Infinity	0.2100			3.102
S16		Infinity	0.5794			3.177
S17	Imaging Plane	Infinity	0.0106			3.529

TABLE 28

	K	A	B	C	D	E	F	G	H
S1	0.0432	-0.0088	0.0131	-0.0627	0.1199	-0.1345	0.077	-0.018	-0.0004
S2	-26.097	-0.0562	0.051	-0.0514	0.0595	-0.0683	0.0462	-0.0139	-7E-05
S3	-99	-0.1283	0.1953	-0.2779	0.5135	-0.8812	0.9662	-0.5723	0.1395
S4	-16.567	-0.0971	0.1552	-0.3608	0.985	-2.059	2.5647	-1.6683	0.4378
S5	-1.6774	-0.0377	0.065	-0.4515	1.687	-3.5163	4.2391	-2.6607	0.6752
S6	57.913	-0.0559	0.0533	-0.341	1.3373	-2.8539	3.4811	-2.2114	0.5781
S7	-66.305	-0.1749	-0.0635	0.0963	-0.2061	0.5819	-0.9	0.6874	-0.1979
S8	19.549	-0.1228	-0.0686	0.0207	0.1647	-0.2695	0.1725	-0.0616	0.0161
S9	29.709	-0.0709	0.0826	-0.3062	0.6009	-0.6459	0.3344	-0.0761	0
S10	-31.338	-0.1255	0.1076	-0.1494	0.1908	-0.1423	0.0506	-0.0065	0
S11	-46.453	0.0038	-0.1455	0.1534	-0.126	0.0705	-0.0225	0.0029	0
S12	-31.504	0.0093	-0.0326	0.0149	-0.0033	0.0003	-1E-05	-7E-07	0
S13	-0.5233	-0.2947	0.1709	-0.0627	0.0154	-0.0025	0.0003	-1E-05	3E-07
S14	-0.8257	-0.2584	0.1353	-0.0565	0.0166	-0.0032	0.0004	-3E-05	7E-07

Fifteenth Example

FIG. 29 is a view illustrating a fifteenth example of an optical imaging system, and FIG. 30 illustrates aberration curves of the optical imaging system of FIG. 29.

An optical imaging system 15 includes a first lens 1015, a second lens 2015, a third lens 3015, a fourth lens 4015, a fifth lens 5015, a sixth lens 6015, and a seventh lens 7015.

The first lens 1015 has a positive refractive power, and an object-side surface thereof is convex and an image-side surface thereof is concave. The second lens 2015 has a

negative refractive power, and an object-side surface thereof is convex and an image-side surface thereof is concave. The third lens 3015 has a positive refractive power, and an object-side surface thereof is convex and an image-side surface thereof is concave. The fourth lens 4015 has a positive refractive power, and an object-side surface thereof is convex and an image-side surface thereof is convex. The fifth lens 5015 has a negative refractive power, and an object-side surface thereof is concave and an image-side surface thereof is convex. The sixth lens 6015 has a positive refractive power, and an object-side surface thereof is convex and an image-side surface thereof is convex. In addition, at least one inflection point is formed on either one or both of the object-side surface and the image-side surface of the sixth lens 6015. The seventh lens 7015 has a negative refractive power, and an object-side surface thereof is concave and an image-side surface thereof is concave. In addition, one inflection point is formed on each of the object-side surface and the image-side surface of the seventh lens 7015.

The optical imaging system 15 further includes a stop, a filter 8015, and an image sensor 9015. The stop is disposed

between the first lens 1015 and the second lens 2015 to adjust an amount of light incident on the image sensor 9015. The filter 8015 is disposed between the seventh lens 7015 and the image sensor 9015 to block infrared rays. The image sensor 9015 forms an imaging plane on which an image of a subject is formed.

Table 29 below shows physical properties of the lenses and other elements of the optical imaging system of FIG. 29, and Table 30 below shows aspherical surface coefficients of the lenses of FIG. 29.

TABLE 29

Surface No.	Element	Radius of Curvature	Thickness/Distance	Index of Refraction	Abbe Number	Effective Aperture Radius
S1	First	1.7773	0.6238	1.544	56.114	1.217
S2	Lens (Stop)	6.4566	0.1000			1.158
S3	Second	4.4103	0.2363	1.661	20.353	1.157
S4	Lens	2.6584	0.4138			1.184
S5	Third	6.5879	0.4640	1.544	56.114	1.177
S6	Lens	10.5233	0.1777			1.282
S7	Fourth	13.4749	0.3627	1.544	56.114	1.306
S8	Lens	-20.2300	0.2325			1.444
S9	Fifth	-3.1831	0.2000	1.661	20.353	1.456
S10	Lens	-4.2151	0.1000			1.625
S11	Sixth	6.7646	0.6089	1.544	56.114	2.207
S12	Lens	-2.8792	0.4211			2.145
S13	Seventh	-6.9958	0.3200	1.544	56.114	2.280
S14	Lens	1.6934	0.1485			3.165
S15	Filter	Infinity	0.1100			2.850
S16		Infinity	0.7007			2.888
S17	Imaging Plane	Infinity	-0.0200			3.276

TABLE 30

	K	A	B	C	D	E	F	G	H	J
S1	-0.5383	0.0108	0.0209	-0.0477	0.0729	-0.06	0.0243	-0.0027	-0.0007	0
S2	5.8135	-0.0459	0.0189	0.0248	-0.0559	0.0486	-0.026	0.0094	-0.0019	0
S3	-10.011	-0.085	0.066	0.02	-0.0808	0.0756	-0.0332	0.0069	-0.0006	0
S4	-0.1875	-0.0544	0.0068	0.26	-0.6655	0.9329	-0.7519	0.3313	-0.061	0
S5	0	-0.0569	0.0063	-0.0275	-0.0046	0.0401	-0.0485	0.0264	-0.0053	0
S6	0	-0.0775	-0.0976	0.271	-0.5329	0.5567	-0.3323	0.1128	-0.0176	0
S7	47.015	-0.0863	-0.1024	0.2298	-0.2721	0.1091	0.0392	-0.0378	0.0065	0
S8	-99	-0.0603	-0.0348	0.057	-0.0468	0.0241	-0.007	0.001	-6E-05	0
S9	-99	-0.2672	0.6153	-0.9745	0.9138	-0.5236	0.1786	-0.0332	0.0026	0
S10	-0.0701	0.0268	-0.0377	-0.0253	0.035	-0.0133	0.0024	-0.0002	7E-06	0
S11	-97.721	0.1556	-0.2109	0.1424	-0.0678	0.02	-0.0033	0.0003	-1E-05	0
S12	-1.5998	0.2298	-0.1811	0.0905	-0.0342	0.0088	-0.0014	0.0001	-4E-06	0
S13	4.8341	-0.1142	-0.0024	0.0306	-0.013	0.0027	-0.0003	2E-05	-5E-07	0
S14	-1.0993	-0.2618	0.1449	-0.0599	0.0171	-0.0032	0.0004	-3E-05	1E-06	-2E-08

Sixteenth Example

FIG. 31 is a view illustrating a sixteenth example of an optical imaging system, and FIG. 32 illustrates aberration curves of the optical imaging system of FIG. 31.

An optical imaging system 16 includes a first lens 1016, a second lens 2016, a third lens 3016, a fourth lens 4016, a fifth lens 5016, a sixth lens 6016, and a seventh lens 7016.

The first lens 1016 has a positive refractive power, and an object-side surface thereof is convex and an image-side surface thereof is concave. The second lens 2016 has a negative refractive power, and an object-side surface thereof is convex and an image-side surface thereof is concave. The third lens 3016 has a negative refractive power, and an object-side surface thereof is convex and an image-side surface thereof is concave. The fourth lens 4016 has a positive refractive power, and an object-side surface thereof is convex and an image-side surface thereof is concave. The fifth lens 5016 has a positive refractive power, and an object-side surface thereof is concave and an image-side surface thereof is convex. The sixth lens 6016 has a positive refractive power, and an object-side surface thereof is convex and an image-side surface thereof is convex. In addition, at least one inflection point is formed on either one or both of the object-side surface and the image-side surface of the

sixth lens 6016. The seventh lens 7016 has a negative refractive power, and an object-side surface thereof is concave and an image-side surface thereof is concave. In addition, no inflection point is formed on the object-side surface of the seventh lens 7016, and one inflection point is formed on the image-side surface of the seventh lens 7016.

The optical imaging system 16 further includes a stop, a filter 8016, and an image sensor 9016. The stop is disposed between the first lens 1016 and the second lens 2016 to adjust an amount of light incident on the image sensor 9016. The filter 8016 is disposed between the seventh lens 7016 and the image sensor 9016 to block infrared rays. The image sensor 9016 forms an imaging plane on which an image of a subject is formed. Although not illustrated in FIG. 31, the stop is disposed at a distance of 0.6409 mm from the object-side surface of the first lens 1016 toward the imaging plane of the optical imaging system 16. This distance is equal to TTL-SL and can be calculated from the values of TTL and SL for Example 16 listed in Table 57 that appears later in this application.

Table 31 below shows physical properties of the lenses and other elements of the optical imaging system of FIG. 31, and Table 32 below shows aspherical surface coefficients of the lenses of FIG. 31.

TABLE 31

Surface No.	Element	Radius of Curvature	Thickness/Distance	Index of Refraction	Abbe Number	Effective Aperture Radius
S1	First	1.7977	0.6409	1.544	56.114	1.270
S2	Lens	3.7422	0.1191			1.211
	(Stop)					
S3	Second	3.0573	0.2200	1.661	20.353	1.190
S4	Lens	2.7951	0.3931			1.130
S5	Third	10.6215	0.4640	1.544	56.114	1.153
S6	Lens	9.0266	0.1000			1.289
S7	Fourth	7.9876	0.3621	1.544	56.114	1.328
S8	Lens	138.7678	0.2334			1.454
S9	Fifth	-4.1765	0.2198	1.661	20.353	1.518
S10	Lens	-4.1394	0.1000			1.656
S11	Sixth	4.6134	0.6089	1.544	56.114	2.000
S12	Lens	-3.5921	0.4726			2.038
S13	Seventh	-7.0016	0.3200	1.544	56.114	2.049
S14	Lens	1.6938	0.1107			2.685
S15	Filter	Infinity	0.2100			2.942
S16		Infinity	0.5300			3.008
S17	Imaging Plane	Infinity	0.0200			3.292

vex and an image-side surface thereof is concave. In addition, one inflection point is formed on each of the object-side surface and the image-side surface of the seventh lens **7017**.

The optical imaging system **17** further includes a stop, a filter **8017**, and an image sensor **9017**. The stop is disposed between the second lens **2017** and the third lens **3017** to adjust an amount of light incident on the image sensor **9017**. The filter **8017** is disposed between the seventh lens **7017** and the image sensor **9017** to block infrared rays. The image sensor **9017** forms an imaging plane on which an image of a subject is formed. Although not illustrated in FIG. **33**, the stop is disposed at a distance of 0.6811 mm from the object-side surface of the first lens **1017** toward the imaging plane of the optical imaging system **17**. This distance is equal to TTL-SL and can be calculated from the values of TTL and SL for Example 17 listed in Table 57 that appears later in this application.

Table 33 below shows physical properties of the lenses and other elements of the optical imaging system of FIG. **33**, and Table 34 below shows aspherical surface coefficients of the lenses of FIG. **33**.

TABLE 32

	K	A	B	C	D	E	F	G	H	J
S1	-0.812	0.0136	0.0311	-0.0769	0.1226	-0.1099	0.0531	-0.0116	0.0005	0
S2	-6.6917	-0.0631	0.0174	0.0714	-0.1648	0.1763	-0.1086	0.0376	-0.0059	0
S3	-14.579	-0.0707	0.0068	0.1319	-0.2129	0.173	-0.0715	0.0127	-0.0005	0
S4	-0.188	-0.0614	-0.0138	0.3338	-0.7392	0.9251	-0.6781	0.276	-0.0477	0
S5	0	-0.0572	0.0435	-0.1733	0.2724	-0.2421	0.0931	-0.0042	-0.0038	0
S6	0	-0.1356	-0.0309	0.2183	-0.5547	0.6931	-0.486	0.1856	-0.0304	0
S7	30.023	-0.2107	0.0007	0.1568	-0.2854	0.2586	-0.1154	0.0236	-0.0019	0
S8	-99	-0.1858	-0.0192	0.2616	-0.4111	0.3392	-0.1538	0.0357	-0.0033	0
S9	-98.995	-0.2935	0.5043	-0.5157	0.2657	-0.0658	0.0056	0.0005	-8E-05	0
S10	-0.0701	-0.0775	0.2223	-0.2703	0.1529	-0.0452	0.0073	-0.0006	2E-05	0
S11	-97.878	0.1479	-0.1956	0.1288	-0.0598	0.0172	-0.0028	0.0002	-8E-06	0
S12	1.4166	0.1234	-0.1416	0.087	-0.0341	0.0088	-0.0014	0.0001	-4E-06	0
S13	9.5503	-0.2864	0.1096	0.0149	-0.0214	0.0064	-0.0009	6E-05	-2E-06	0
S14	-1.2786	-0.3076	0.1777	-0.0626	0.0143	-0.0022	0.0002	-1E-05	5E-07	-7E-09

Seventeenth Example

FIG. **33** is a view illustrating a seventeenth example of an optical imaging system, and FIG. **34** illustrates aberration curves of the optical imaging system of FIG. **33**.

An optical imaging system **17** includes a first lens **1017**, a second lens **2017**, a third lens **3017**, a fourth lens **4017**, a fifth lens **5017**, a sixth lens **6017**, and a seventh lens **7017**.

The first lens **1017** has a positive refractive power, and an object-side surface thereof is convex and an image-side surface thereof is concave. The second lens **2017** has a negative refractive power, and an object-side surface thereof is convex and an image-side surface thereof is concave. The third lens **3017** has a negative refractive power, and an object-side surface thereof is convex and an image-side surface thereof is concave. The fourth lens **4017** has a positive refractive power, and an object-side surface thereof is convex and an image-side surface thereof is convex. The fifth lens **5017** has a negative refractive power, and an object-side surface thereof is concave and an image-side surface thereof is convex. The sixth lens **6017** has a negative refractive power, and an object-side surface thereof is convex and an image-side surface thereof is concave. In addition, at least one inflection point is formed on either one or both of the object-side surface and the image-side surface of the sixth lens **6017**. The seventh lens **7017** has a negative refractive power, and an object-side surface thereof is con-

TABLE 33

Surface No.	Element	Radius of Curvature	Thickness/Distance	Index of Refraction	Abbe Number	Effective Aperture Radius
S1	First	1.5114	0.4703	1.547	56.114	1.072
S2	Lens	6.0961	0.0200			1.048
S3	Second	1.7572	0.1895	1.660	20.400	0.992
S4	Lens	1.2936	0.3871			0.909
	(Stop)					
S5	Third	3.5767	0.1000	1.660	20.400	0.903
S6	Lens	3.3323	0.2006			0.933
S7	Fourth	8.9505	0.6399	1.547	56.114	1.084
S8	Lens	-56.3031	0.3491			1.273
S9	Fifth	-8.7735	0.1490	1.650	21.494	1.334
S10	Lens	-11.1487	0.0575			1.573
S11	Sixth	4.0153	0.5539	1.650	21.494	1.601
S12	Lens	3.7824	0.2451			1.999
S13	Seventh	1.9199	0.5114	1.537	55.711	2.819
S14	Lens	1.4533	0.1829			2.581
S15	Filter	Infinity	0.1100			2.895
S16		Infinity	0.5173			2.935
S17	Imaging Plane	Infinity	0.0150			3.262

TABLE 34

	K	A	B	C	D	E	F	G	H	J
S1	-0.0872	0.0085	0.0157	-0.0318	0.0507	-0.0457	0.0214	-0.0042	0	0
S2	25.924	-0.1035	0.4079	-0.9853	1.3538	-1.1103	0.5053	-0.1003	0	0
S3	-2.0252	-0.1329	0.5024	-1.13	1.5305	-1.218	0.5394	-0.1043	0	0
S4	-0.1481	-0.094	0.1762	-0.1747	-0.0182	0.4162	-0.4298	0.1625	0	0
S5	0.829	-0.1421	0.1795	-0.2535	0.4392	-0.4879	0.3327	-0.0954	0	0
S6	6.8952	-0.1777	0.1545	-0.1149	0.1034	-0.051	0.0095	-0.0002	0	0
S7	21.918	-0.0605	0.0485	-0.0459	0.0715	-0.0485	0.0135	-0.0013	0	0
S8	25.736	-0.0682	0.0239	-0.012	0.0083	-0.0027	0.0004	-2E-05	0	0
S9	1.6857	-0.1292	0.2433	-0.407	0.387	-0.2241	0.0741	-0.011	0	0
S10	43.884	-0.107	0.1148	-0.1454	0.095	-0.0303	0.0045	-0.0003	0	0
S11	-52.836	0.0701	-0.2199	0.2058	-0.1343	0.0526	-0.0106	0.0009	0	0
S12	0	-0.0577	-0.027	0.0237	-0.0104	0.0019	0.0002	-0.0001	2E-05	-6E-07
S13	-0.9427	-0.3217	0.0977	-0.0029	-0.0058	0.0017	-0.0002	2E-05	-4E-07	0
S14	-1.0048	-0.2798	0.1282	-0.0461	0.0122	-0.0022	0.0002	-1E-05	4E-07	0

Eighteenth Example

FIG. 35 is a view illustrating an eighteenth example of an optical imaging system, and FIG. 36 illustrates aberration curves of the optical imaging system of FIG. 35.

An optical imaging system 18 includes a first lens 1018, a second lens 2018, a third lens 3018, a fourth lens 4018, a fifth lens 5018, a sixth lens 6018, and a seventh lens 7018.

The first lens 1018 has a positive refractive power, and an object-side surface thereof is convex and an image-side surface thereof is concave. The second lens 2018 has a positive refractive power, and an object-side surface thereof is convex and an image-side surface thereof is concave. The third lens 3018 has a negative refractive power, and an object-side surface thereof is convex and an image-side surface thereof is concave. The fourth lens 4018 has a negative refractive power, and an object-side surface thereof is convex and an image-side surface thereof is concave. The fifth lens 5018 has a positive refractive power, and an object-side surface thereof is convex and an image-side surface thereof is concave. The sixth lens 6018 has a positive refractive power, and an object-side surface thereof is convex and an image-side surface thereof is convex. In addition, at least one inflection point is formed on either one or both of the object-side surface and the image-side surface of the sixth lens 6018. The seventh lens 7018 has a negative refractive power, and an object-side surface thereof is concave and an image-side surface thereof is concave. In addition, one inflection point is formed on each of the object-side surface and the image-side surface of the seventh lens 7018.

The optical imaging system 18 further includes a stop, a filter 8018, and an image sensor 9018. The stop is disposed between the second lens 2018 and the third lens 3018 to adjust an amount of light incident on the image sensor 9018. The filter 8018 is disposed between the seventh lens 7018

and the image sensor 9018 to block infrared rays. The image sensor 9018 forms an imaging plane on which an image of a subject is formed. Although not illustrated in FIG. 35, the stop is disposed at a distance of 1.0512 mm from the object-side surface of the first lens 1018 toward the imaging plane of the optical imaging system 18. This distance is equal to TTL-SL and can be calculated from the values of TTL and SL for Example 18 listed in Table 57 that appears later in this application.

Table 35 below shows physical properties of the lenses and other elements of the optical imaging system of FIG. 35, and Table 36 below shows aspherical surface coefficients of the lenses of FIG. 35.

TABLE 35

Surface No.	Element	Radius of Curvature	Thickness/Distance	Index of Refraction	Abbe Number	Effective Aperture Radius
S1	First	1.8221	0.5822	1.544	56.114	1.275
S2	Lens	4.8276	0.0564			1.231
S3	Second	4.5461	0.3826	1.544	56.114	1.199
S4	Lens	15.5127	0.0300			1.152
S5	(Stop)	3.9113	0.2000	1.661	20.350	1.086
S6	Third Lens	2.2301	0.3911			1.050
S7	Fourth	14.8039	0.3510	1.544	56.114	1.050
S8	Lens	6.0045	0.0516			1.178
S9	Fifth	4.0426	0.2943	1.639	21.525	1.235
S10	Lens	6.0069	0.3029			1.433
S11	Sixth	50.3009	0.5717	1.544	56.114	1.650
S12	Lens	-1.4551	0.3562			2.029
S13	Seventh	-3.9227	0.3400	1.544	56.114	2.473
S14	Lens	1.8149	0.1800			2.629
S15	Filter	Infinity	0.2100	1.518	64.197	
S16		Infinity	0.6200			
S17	Imaging Plane	Infinity	0.0200			

TABLE 36

	K	A	B	C	D	E	F	G	H
S1	-1.7971	0.02	0.0153	-0.0575	0.0794	-0.0689	0.0296	-0.0048	0
S2	0	-0.0249	-0.1102	0.1727	-0.1632	0.1101	-0.0441	0.0076	0
S3	0	0.0215	-0.1293	0.2068	-0.2278	0.2	-0.1022	0.0204	0
S4	72.117	-0.0714	0.2664	-0.6184	0.7522	-0.5313	0.203	-0.0324	0
S5	-15.337	-0.2046	0.4728	-0.8108	0.9542	-0.6926	0.2852	-0.0496	0
S6	-5.3786	-0.102	0.2031	-0.1151	-0.1096	0.3352	-0.285	0.0916	0
S7	0	-0.0443	-0.0061	-0.1088	0.0952	-0.0067	-0.0694	0.0382	0
S8	0	-0.1919	0.079	0.0071	-0.1552	0.1775	-0.0954	0.0212	0
S9	-54.709	-0.2046	-0.0908	0.3474	-0.3213	0.1526	-0.0388	0.0033	0
S10	0	-0.1486	-0.156	0.3054	-0.2298	0.1087	-0.0342	0.0052	0
S11	0	0.0817	-0.1186	-0.0496	0.1291	-0.0835	0.0241	-0.0026	0

TABLE 36-continued

	K	A	B	C	D	E	F	G	H
S12	-1.7559	0.2122	-0.171	0.0184	0.0388	-0.0196	0.0037	-0.0003	0
S13	-4.6993	0.0063	-0.2121	0.1837	-0.071	0.0154	-0.0019	0.0001	-4E-06
S14	-1.1263	-0.2142	0.0916	-0.0298	0.0072	-0.0012	0.0001	-9E-06	3E-07

Nineteenth Example

FIG. 37 is a view illustrating a nineteenth example of an optical imaging system, and FIG. 38 illustrates aberration curves of the optical imaging system of FIG. 37.

An optical imaging system 19 includes a first lens 1019, a second lens 2019, a third lens 3019, a fourth lens 4019, a fifth lens 5019, a sixth lens 6019, and a seventh lens 7019.

The first lens 1019 has a negative refractive power, and an object-side surface thereof is convex and an image-side surface thereof is concave. The second lens 2019 has a positive refractive power, and an object-side surface thereof is convex and an image-side surface thereof is concave. The third lens 3019 has a negative refractive power, and an object-side surface thereof is convex and an image-side surface thereof is concave. The fourth lens 4019 has a negative refractive power, and an object-side surface thereof is convex and an image-side surface thereof is concave. The fifth lens 5019 has a positive refractive power, and an object-side surface thereof is convex and an image-side surface thereof is concave. The sixth lens 6019 has a positive refractive power, and an object-side surface thereof is convex and an image-side surface thereof is convex. In addition, at least one inflection point is formed on either one or both of the object-side surface and the image-side surface of the sixth lens 6019. The seventh lens 7019 has a negative refractive power, and an object-side surface thereof is concave and an image-side surface thereof is concave. In addition, one inflection point is formed on the object-side surface of the seventh lens 7019, and two inflection points are formed on the image-side surface of the seventh lens 7019.

The optical imaging system 19 further includes a stop, a filter 8019, and an image sensor 9019. The stop is disposed between the first lens 1019 and the second lens 2019 to adjust an amount of light incident on the image sensor 9019. The filter 8019 is disposed between the seventh lens 7019 and the image sensor 9019 to block infrared rays. The image sensor 9019 forms an imaging plane on which an image of

a subject is formed. Although not illustrated in FIG. 37, the stop is disposed at a distance of 0.3740 mm from the object-side surface of the first lens 1019 toward the imaging plane of the optical imaging system 19. This distance is equal to TTL-SL and can be calculated from the values of TTL and SL for Example 19 listed in Table 57 that appears later in this application.

Table 37 below shows physical properties of the lenses and other elements of the optical imaging system of FIG. 37, and Table 38 below shows aspherical surface coefficients of the lenses of FIG. 37.

TABLE 37

Surface No.	Element	Radius of Curvature	Thickness/Distance	Index of Refraction	Abbe Number	Effective Aperture Radius
S1	First	2.1873	0.3243	1.546	56.114	1.450
S2	Lens	1.8391	0.0497			1.441
S3	(Stop)	1.6361	0.7740	1.546	56.114	1.415
S4	Second	30.6063	0.0300			1.354
S5	Third	7.2628	0.2100	1.678	19.236	1.270
S6	Lens	2.9652	0.4149			1.120
S7	Fourth	14.3312	0.3269	1.645	23.528	1.182
S8	Lens	12.1292	0.2502			1.337
S9	Fifth	2.1804	0.2500	1.645	23.528	1.580
S10	Lens	2.1733	0.3831			1.892
S11	Sixth	8.6678	0.6610	1.546	56.114	2.429
S12	Lens	-1.9375	0.3110			2.544
S13	Seventh	-7.6533	0.3650	1.546	56.114	2.916
S14	Lens	1.6261	0.2200			3.075
S15	Filter	Infinity	0.1100	1.518	64.166	3.378
S16		Infinity	0.6351			3.414
S17	Imaging Plane	Infinity	0.0049			3.763

TABLE 38

	K	A	B	C	D	E	F	G	H
S1	-3.7488	0.0012	-0.0066	-0.0004	-0.0198	0.0252	-0.0132	0.0034	-0.0004
S2	-7.1577	-0.061	-0.0104	0.0163	0.0115	-0.0163	0.0063	-0.0009	0
S3	-2.6408	-0.0742	0.0698	-0.0582	0.0727	-0.0412	0.0034	0.0048	-0.0013
S4	-99	-0.0752	0.197	-0.3925	0.5174	-0.4377	0.2286	-0.0663	0.008
S5	0	-0.1076	0.2644	-0.4642	0.6109	-0.5485	0.3128	-0.0997	0.0134
S6	4.364	-0.0584	0.0882	-0.068	-0.0405	0.1629	-0.1817	0.0962	-0.0201
S7	0	-0.0603	0.0743	-0.2389	0.4197	-0.4882	0.353	-0.1472	0.0274
S8	0	-0.1174	0.165	-0.2983	0.348	-0.2864	0.1556	-0.0507	0.0077
S9	-15.429	-0.0562	0.0005	0.0397	-0.0576	0.0355	-0.0117	0.0015	3E-05
S10	-9.1654	-0.1003	0.0623	-0.0379	0.0141	-0.0032	5E-05	0.0002	-3E-05
S11	0	-0.001	-0.0216	0.0157	-0.0111	0.0043	-0.0009	8E-05	-3E-06
S12	-1.7327	0.1074	-0.0935	0.0649	-0.0289	0.0078	-0.0012	0.0001	-4E-06
S13	0.6082	-0.1509	0.0462	0.0036	-0.0043	0.001	-0.0001	6E-06	-2E-07
S14	-8.5925	-0.0951	0.041	-0.0124	0.0026	-0.0004	4E-05	-2E-06	4E-08

FIG. 39 is a view illustrating a twentieth example of an optical imaging system, and FIG. 40 illustrates aberration curves of the optical imaging system of FIG. 39.

An optical imaging system 20 includes a first lens 1020, a second lens 2020, a third lens 3020, a fourth lens 4020, a fifth lens 5020, a sixth lens 6020, and a seventh lens 7020.

The first lens 1020 has a positive refractive power, and an object-side surface thereof is convex and an image-side surface thereof is concave. The second lens 2020 has a negative refractive power, and an object-side surface thereof is convex and an image-side surface thereof is concave. The third lens 3020 has a positive refractive power, and an object-side surface thereof is convex and an image-side surface thereof is concave. The fourth lens 4020 has a negative refractive power, and an object-side surface thereof is convex and an image-side surface thereof is concave. The fifth lens 5020 has a negative refractive power, and an object-side surface thereof is convex and an image-side surface thereof is concave. The sixth lens 6020 has a positive refractive power, and an object-side surface thereof is convex and an image-side surface thereof is convex. In addition, at least one inflection point is formed on either one or both of the object-side surface and the image-side surface of the sixth lens 6020. The seventh lens 7020 has a negative refractive power, and an object-side surface thereof is concave and an image-side surface thereof is concave. In addition, one inflection point is formed on the object-side surface of the seventh lens 7020, and two inflection points are formed on the image-side surface of the seventh lens 7020.

Surface No.	Element	Radius of Curvature	Thickness/Distance	Index of Refraction	Abbe Number	Effective
						Aperture Radius
S1	First	2.0122	1.0601	1.546	56.114	1.510
S2	Lens	5.8868	0.0711			1.375
	(Stop)					
S3	Second	5.4922	0.2000	1.677	19.238	1.353
S4	Lens	3.7029	0.2969			1.240
S5	Third	9.9760	0.3703	1.546	56.114	1.270
S6	Lens	29.4320	0.1826			1.356
S7	Fourth	8.6841	0.2108	1.667	20.377	1.355
S8	Lens	6.0112	0.2603			1.479
S9	Fifth	5.7445	0.2195	1.619	25.960	1.750
S10	Lens	5.0434	0.3482			1.736
S11	Sixth	4.8476	0.9335	1.546	56.114	2.400
S12	Lens	-1.7967	0.3268			2.438
S13	Seventh	-1.9512	0.3000	1.546	56.114	2.692
S14	Lens	2.8062	0.1700			3.158
S15	Filter	Infinity	0.2100	1.518	64.197	3.744
S16		Infinity	0.6441			3.826
S17	Imaging Plane	Infinity	-0.0041			4.252

TABLE 40

	K	A	B	C	D	E	F	G	H	J
S1	-1.1332	0.0154	0.0091	-0.0108	0.01	-0.0053	0.0015	-0.0002	-1E-05	0
S2	12.901	-0.0771	0.0315	0.036	-0.0911	0.0858	-0.0454	0.0132	-0.0016	0
S3	9.6379	-0.1255	0.0603	0.0962	-0.2261	0.222	-0.1214	0.036	-0.0045	0
S4	-0.8719	-0.061	0.0524	0.0027	0.0041	-0.069	0.0931	-0.0498	0.0101	0
S5	0	-0.0121	0.0151	-0.088	0.1573	-0.1697	0.1016	-0.0315	0.004	0
S6	-99	-0.0237	-0.0073	0.0365	-0.1182	0.1732	-0.1421	0.0603	-0.0104	0
S7	0	-0.104	-0.0751	0.2741	-0.5665	0.6635	-0.4435	0.1557	-0.0222	0
S8	0	-0.1088	0.0332	-0.0258	-0.0057	0.0249	-0.0175	0.0048	-0.0003	0
S9	0	-0.1824	0.192	-0.1693	0.1022	-0.0423	0.0117	-0.002	0.0002	0
S10	-96.971	-0.1318	0.0661	-0.0223	-0.0048	0.0087	-0.0034	0.0006	-4E-05	0
S11	-34.065	-0.0075	-0.0001	-0.0106	0.0081	-0.0035	0.0008	-1E-04	4E-06	0
S12	-2.7443	0.1131	-0.0726	0.0291	-0.0078	0.0012	-9E-05	1E-06	1E-07	0
S13	-10.221	-0.0393	-0.0198	0.0148	-0.0036	0.0005	-3E-05	1E-06	-2E-08	0
S14	-1.2844	-0.0938	0.0319	-0.0092	0.002	-0.0003	4E-05	-3E-06	1E-07	-3E-09

The optical imaging system 20 further includes a stop, a filter 8020, and an image sensor 9020. The stop is disposed between the first lens 1020 and the second lens 2020 to adjust an amount of light incident on the image sensor 9020. The filter 8020 is disposed between the seventh lens 7020 and the image sensor 9020 to block infrared rays. The image sensor 9020 forms an imaging plane on which an image of a subject is formed. Although not illustrated in FIG. 39, the stop is disposed at a distance of 1.0601 mm from the object-side surface of the first lens 1020 toward the imaging plane of the optical imaging system 20. This distance is equal to TTL-SL and can be calculated from the values of TTL and SL for Example 20 listed in Table 57 that appears later in this application.

Table 39 below shows physical properties of the lenses and other elements of the optical imaging system of FIG. 39, and Table 40 below shows aspherical surface coefficients of the lenses of FIG. 39.

Twenty-First Example

FIG. 41 is a view illustrating a twenty-first example of an optical imaging system, and FIG. 42 illustrates aberration curves of the optical imaging system of FIG. 41.

An optical imaging system 21 includes a first lens 1021, a second lens 2021, a third lens 3021, a fourth lens 4021, a fifth lens 5021, a sixth lens 6021, and a seventh lens 7021.

The first lens 1021 has a positive refractive power, and an object-side surface thereof is convex and an image-side surface thereof is concave. The second lens 2021 has a positive refractive power, and an object-side surface thereof is convex and an image-side surface thereof is concave. The third lens 3021 has a negative refractive power, and an object-side surface thereof is convex and an image-side surface thereof is concave. The fourth lens 4021 has a positive refractive power, and an object-side surface thereof

is convex and an image-side surface thereof is concave. The fifth lens **5021** has a negative refractive power, and an object-side surface thereof is convex and an image-side surface thereof is concave. The sixth lens **6021** has a positive refractive power, and an object-side surface thereof is convex and an image-side surface thereof is concave. In addition, at least one inflection point is formed on either one or both of the object-side surface and the image-side surface of the sixth lens **6021**. The seventh lens **7021** has a positive refractive power, and an object-side surface thereof is convex and an image-side surface thereof is concave. In addition, two inflection points are formed on the object-side

TABLE 41-continued

Surface No.	Element	Radius of Curvature	Thickness/Distance	Index of Refraction	Abbe Number	Effective Aperture Radius
S13	Seventh	1.4290	0.5074	1.546	56.114	2.691
S14	Lens	1.2861	0.4042			2.841
S15	Filter	Infinity	0.2100	1.518	64.197	3.245
S16		Infinity	0.6767			3.316
S17	Imaging Plane	Infinity	0.0150			3.733

TABLE 42

	K	A	B	C	D	E	F	G	H	J
S1	-0.9855	-0.0214	0.0439	-0.0925	0.0633	0.0064	-0.0479	0.0372	-0.0126	0.0016
S2	-12.849	0.0234	-0.0441	-0.1546	-0.0352	0.7096	-1.0004	0.6322	-0.1959	0.0242
S3	-1.1002	-0.0276	0.0854	-0.4269	0.4011	0.3152	-0.8128	0.5995	-0.2021	0.0266
S4	-7.367	-0.1684	1.4677	-5.7804	12.64	-16.742	13.734	-6.8183	1.8769	-0.22
S5	9.3187	-0.2245	1.5162	-5.8569	13.059	-17.823	15.121	-7.7778	2.2231	-0.2714
S6	1.6265	-0.0856	0.2704	-0.9806	2.415	-3.7649	3.6777	-2.1905	0.7327	-0.1058
S7	-4.7815	0.0264	-0.5178	1.9131	-4.2532	5.8667	-5.0521	2.6239	-0.7455	0.0886
S8	5.8592	-0.0338	-0.0317	0.0097	0.0291	-0.0644	0.0612	-0.0311	0.0084	-0.0008
S9	-43.521	-0.002	-0.0021	0.0436	-0.1236	0.1389	-0.0871	0.0311	-0.0059	0.0005
S10	-12.729	-0.0608	0.0286	0.0052	-0.0244	0.0182	-0.0074	0.0018	-0.0002	1E-05
S11	-16.199	0.1227	-0.2762	0.2845	-0.2154	0.1043	-0.0311	0.0056	-0.0006	2E-05
S12	0.0242	-0.0902	0.058	-0.0568	0.029	-0.0088	0.0017	-0.0002	2E-05	-5E-07
S13	-0.8394	-0.4114	0.2062	-0.0647	0.0137	-0.0021	0.0003	-2E-05	2E-06	-5E-08
S14	-1.3743	-0.2983	0.1734	-0.0777	0.0258	-0.006	0.0009	-9E-05	5E-06	-1E-07

surface of the seventh lens **7021**, and one inflection point is formed on the image-side surface of the seventh lens **7021**.

The optical imaging system **21** further includes a stop, a filter **8021**, and an image sensor **9021**. The stop is disposed between the second lens **2021** and the third lens **3021** to adjust an amount of light incident on the image sensor **9021**. The filter **8021** is disposed between the seventh lens **7021** and the image sensor **9021** to block infrared rays. The image sensor **9021** forms an imaging plane on which an image of a subject is formed. Although not illustrated in FIG. **41**, the stop is disposed at a distance of 1.1280 mm from the object-side surface of the first lens **1021** toward the imaging plane of the optical imaging system **21**. This distance is equal to TTL-SL and can be calculated from the values of TTL and SL for Example 21 listed in Table 57 that appears later in this application.

Table 41 below shows physical properties of the lenses and other elements of the optical imaging system of FIG. **41**, and Table 42 below shows aspherical surface coefficients of the lenses of FIG. **41**.

TABLE 41

Surface No.	Element	Radius of Curvature	Thickness/Distance	Index of Refraction	Abbe Number	Effective Aperture Radius
S1	First	2.1378	0.4606	1.546	56.114	1.360
S2	Lens	2.7210	0.0424			1.346
S3	Second	2.7717	0.6000	1.546	56.114	1.322
S4	Lens	33.8379	0.0250			1.253
S5	(Stop)	5.9058	0.2300	1.679	19.236	1.199
S6	Third Lens	2.9580	0.3150			1.193
S7	Fourth	6.7061	0.5156	1.546	56.114	1.246
S8	Lens	15.6197	0.4883			1.350
S9	Fifth	9.4476	0.3912	1.679	19.236	1.600
S10	Lens	5.2667	0.1323			2.100
S11	Sixth	2.4900	0.4534	1.546	56.114	1.951
S12	Lens	2.6058	0.1501			2.440

Twenty-Second Example

FIG. **43** is a view illustrating a twenty-second example of an optical imaging system, and FIG. **44** illustrates aberration curves of the optical imaging system of FIG. **43**.

An optical imaging system **22** includes a first lens **1022**, a second lens **2022**, a third lens **3022**, a fourth lens **4022**, a fifth lens **5022**, a sixth lens **6022**, and a seventh lens **7022**.

The first lens **1022** has a positive refractive power, and an object-side surface thereof is convex and an image-side surface thereof is concave. The second lens **2022** has a positive refractive power, and an object-side surface thereof is convex and an image-side surface thereof is convex. The third lens **3022** has a negative refractive power, and an object-side surface thereof is convex and an image-side surface thereof is concave. The fourth lens **4022** has a positive refractive power, and an object-side surface thereof is convex and an image-side surface thereof is concave. The fifth lens **5022** has a negative refractive power, and an object-side surface thereof is convex and an image-side surface thereof is concave. The sixth lens **6022** has a positive refractive power, and an object-side surface thereof is convex and an image-side surface thereof is concave. In addition, at least one inflection point is formed on either one or both of the object-side surface and the image-side surface of the sixth lens **6022**. The seventh lens **7022** has a positive refractive power, and an object-side surface thereof is convex and an image-side surface thereof is concave. In addition, one inflection point is formed on each of the object-side surface and the image-side surface of the seventh lens **7022**.

The optical imaging system **22** further includes a stop, a filter **8022**, and an image sensor **9022**. The stop is disposed between the second lens **2022** and the third lens **3022** to adjust an amount of light incident on the image sensor **9022**. The filter **8022** is disposed between the seventh lens **7022** and the image sensor **9022** to block infrared rays. The image sensor **9022** forms an imaging plane on which an image of

a subject is formed. Although not illustrated in FIG. 43, the stop is disposed at a distance of 1.2251 mm from the object-side surface of the first lens 1022 toward the imaging plane of the optical imaging system 22. This distance is equal to TTL-SL and can be calculated from the values of TTL and SL for Example 22 listed in Table 57 that appears later in this application.

Table 43 below shows physical properties of the lenses and other elements of the optical imaging system of FIG. 43, and Table 44 below shows aspherical surface coefficients of the lenses of FIG. 43.

TABLE 43

Surface No.	Element	Radius of Curvature	Thickness/Distance	Index of Refraction	Abbe Number	Effective Aperture Radius
S1	First	2.2670	0.4000	1.546	56.114	1.380
S2	Lens	2.6691	0.0251			1.337
S3	Second	2.6238	0.8000	1.546	56.114	1.337
S4	Lens (Stop)	-11.8758	0.0250			1.298
S5	Third	19.0032	0.2526	1.679	19.236	1.202
S6	Lens	4.0676	0.4108			1.242
S7	Fourth	6.6991	0.3500	1.679	19.236	1.265
S8	Lens	7.2200	0.4296			1.369
S9	Fifth	21.5310	0.3500	1.546	56.114	1.600
S10	Lens	7.8918	0.0250			1.853
S11	Sixth	2.5030	0.4300	1.546	56.114	1.908
S12	Lens	2.4093	0.2399			2.372
S13	Seventh	1.3275	0.5254	1.546	56.114	2.507
S14	Lens	1.1947	0.3215			2.738
S15	Filter	Infinity	0.2100	1.518	64.197	3.205
S16		Infinity	0.6902			3.285
S17	Imaging Plane	Infinity	0.0150			3.781

TABLE 44

	K	A	B	C	D	E	F	G	H	J
S1	-1	0.0012	-0.0631	0.0884	-0.0759	-0.0183	0.0824	-0.0602	0.019	-0.0023
S2	-11.056	0.038	0.1354	-0.9871	1.5641	-1.0995	0.3265	0.0108	-0.0287	0.0048
S3	-0.7436	-0.0807	0.579	-1.9725	2.9346	-2.2115	0.8223	-0.0859	-0.0317	0.0076
S4	-7.2488	-0.1245	0.5877	-1.6544	2.8953	-3.2415	2.3118	-1.0127	0.2473	-0.0257
S5	12.337	-0.1601	0.4751	-0.9119	1.1418	-0.9059	0.4213	-0.0904	-0.0021	0.0031
S6	-0.7614	-0.0925	0.1749	-0.2349	0.2283	-0.1666	0.0772	-0.0124	-0.0054	0.0021
S7	-12.018	0.047	-0.734	2.692	-5.8982	8.0627	-6.9318	3.6331	-1.0592	0.1316
S8	5.8397	-0.055	0.0238	-0.178	0.4679	-0.6732	0.5802	-0.2983	0.0845	-0.0101
S9	-43.467	0.0208	-0.0298	0.0644	-0.1157	0.1018	-0.0488	0.0125	-0.0016	7E-05
S10	-10.152	-0.0392	0.0146	0.0256	-0.0749	0.0675	-0.0305	0.0074	-0.0009	5E-05
S11	-16.19	0.0915	-0.1594	0.2045	-0.2282	0.1461	-0.0541	0.0117	-0.0014	7E-05
S12	-0.0871	-0.1985	0.3277	-0.3309	0.1866	-0.0647	0.0141	-0.0019	0.0001	-4E-06
S13	-0.8728	-0.462	0.2873	-0.1331	0.0447	-0.0104	0.0016	-0.0002	9E-06	-2E-07
S14	-1.5388	-0.3036	0.1844	-0.0807	0.0232	-0.0042	0.0005	-3E-05	1E-06	-1E-08

Twenty-Third Example

FIG. 45 is a view illustrating a twenty-third example of an optical imaging system, and FIG. 46 illustrates aberration curves of the optical imaging system of FIG. 45.

An optical imaging system 23 includes a first lens 1023, a second lens 2023, a third lens 3023, a fourth lens 4023, a fifth lens 5023, a sixth lens 6023, and a seventh lens 7023.

The first lens 1023 has a positive refractive power, and an object-side surface thereof is convex and an image-side surface thereof is concave. The second lens 2023 has a negative refractive power, and an object-side surface thereof is convex and an image-side surface thereof is concave. The third lens 3023 has a negative refractive power, and an object-side surface thereof is convex and an image-side

surface thereof is concave. The fourth lens 4023 has a positive refractive power, and an object-side surface thereof is convex and an image-side surface thereof is concave. The fifth lens 5023 has a negative refractive power, and an object-side surface thereof is convex and an image-side surface thereof is concave. The sixth lens 6023 has a negative refractive power, and an object-side surface thereof is concave and an image-side surface thereof is concave. In addition, at least one inflection point is formed on either one or both of the object-side surface and the image-side surface of the sixth lens 6023. The seventh lens 7023 has a positive refractive power, and an object-side surface thereof is convex and an image-side surface thereof is concave. In addition, two inflection points are formed on the object-side surface of the seventh lens 7023, and one inflection point is formed on the image-side surface of the seventh lens 7023.

The optical imaging system 23 further includes a stop, a filter 8023, and an image sensor 9023. The stop is disposed between the second lens 2023 and the third lens 3023 to adjust an amount of light incident on the image sensor 9023. The filter 8023 is disposed between the seventh lens 7023 and the image sensor 9023 to block infrared rays. The image sensor 9023 forms an imaging plane on which an image of a subject is formed. Although not illustrated in FIG. 45, the stop is disposed at a distance of 0.9515 mm from the object-side surface of the first lens 1023 toward the imaging plane of the optical imaging system 23. This distance is equal to TTL-SL and can be calculated from the values of TTL and SL for Example 23 listed in Table 57 that appears later in this application.

Table 45 below shows physical properties of the lenses and other elements of the optical imaging system of FIG. 45, and Table 46 below shows aspherical surface coefficients of the lenses of FIG. 45.

TABLE 45

Surface No.	Element	Radius of Curvature	Thickness/Distance	Index of Refraction	Abbe Number	Effective Aperture Radius
S1	First	1.7473	0.6964	1.546	56.114	1.280
S2	Lens	9.4084	0.0250			1.247
S3	Second	2.9766	0.2300	1.667	20.353	1.150
S4	Lens (Stop)	1.9564	0.3428			1.007
S5	Third	16.8676	0.2300	1.667	20.353	1.032
S6	Lens	16.0126	0.0294			1.089
S7	Fourth	7.3144	0.3570	1.546	56.114	1.130
S8	Lens	17.3919	0.3708			1.228
S9	Fifth	11.5617	0.3608	1.656	21.525	1.317
S10	Lens	6.9184	0.2917			1.657

TABLE 45-continued

Surface No.	Element	Radius of Curvature	Thickness/Distance	Index of Refraction	Abbe Number	Effective Aperture Radius
S11	Sixth	-97.1635	0.5908	1.656	21.525	1.878
S12	Lens	17.2767	0.0301			2.338
S13	Seventh	1.9322	0.8258	1.546	56.114	2.961
S14	Lens	1.7390	0.2207			3.015
S15	Filter	Infinity	0.2100	1.518	64.197	3.305
S16		Infinity	0.6356			3.375
S17	Imaging Plane	Infinity	0.0143			3.731

surface of the seventh lens **7024**, and one inflection point is formed on the image-side surface of the seventh lens **7024**.

The optical imaging system **24** further includes a stop, a filter **8024**, and an image sensor **9024**. The stop is disposed between the first lens **1024** and the second lens **2024** to adjust an amount of light incident on the image sensor **9024**. The filter **8024** is disposed between the seventh lens **7024** and the image sensor **9024** to block infrared rays. The image sensor **9024** forms an imaging plane on which an image of a subject is formed. Although not illustrated in FIG. **47**, the stop is disposed at a distance of 0.8574 mm from the object-side surface of the first lens **1024** toward the imaging plane of the optical imaging system **24**. This distance is

TABLE 46

	K	A	B	C	D	E	F	G	H	J
S1	-0.3029	0.0003	0.0248	-0.0645	0.0887	-0.0757	0.0373	-0.0109	0.0014	0
S2	0.9997	-0.0385	0.0595	-0.0639	0.0052	0.0552	-0.0624	0.0296	-0.0054	0
S3	-1.759	-0.0559	0.0769	-0.084	0.0959	-0.0711	0.0309	-0.0026	-0.0012	0
S4	-0.2233	-0.022	-0.0153	0.1358	-0.2648	0.3311	-0.2167	0.051	0.0098	0
S5	-0.8179	-0.0092	-0.0103	-0.1607	0.6303	-1.1881	1.2746	-0.7449	0.1847	0
S6	-0.0005	0.02	-0.1312	0.1142	-0.0014	0.0632	-0.1761	0.1336	-0.0335	0
S7	-31.717	0.0266	-0.0935	-0.0104	0.2126	-0.2049	0.0541	0.02	-0.0098	0
S8	-1.0151	-0.0315	0.0288	-0.0714	0.0935	-0.1394	0.1768	-0.1344	0.0524	-0.0076
S9	0.382	-0.1094	0.0327	-0.0826	0.2138	-0.3162	0.2427	-0.0962	0.0156	0
S10	-27.524	-0.0394	-0.117	0.1628	-0.1238	0.0551	-0.0144	0.0023	-0.0002	0
S11	23.203	0.1802	-0.2793	0.2208	-0.1258	0.0475	-0.0113	0.0016	-0.0001	0
S12	-49.948	0.0336	-0.0362	0.0098	-0.0011	-0.0001	8E-05	-1E-05	6E-07	0
S13	-1.8504	-0.2437	0.1076	-0.031	0.0066	-0.001	0.0001	-6E-06	1E-07	0
S14	-0.8299	-0.173	0.0629	-0.0196	0.0044	-0.0006	6E-05	-3E-06	6E-08	0

Twenty-Fourth Example

FIG. **47** is a view illustrating a twenty-fourth example of an optical imaging system, and FIG. **48** illustrates aberration curves of the optical imaging system of FIG. **47**.

An optical imaging system **24** includes a first lens **1024**, a second lens **2024**, a third lens **3024**, a fourth lens **4024**, a fifth lens **5024**, a sixth lens **6024**, and a seventh lens **7024**.

The first lens **1024** has a positive refractive power, and an object-side surface thereof is convex and an image-side surface thereof is concave. The second lens **2024** has a negative refractive power, and an object-side surface thereof is convex and an image-side surface thereof is concave. The third lens **3024** has a positive refractive power, and an object-side surface thereof is convex and an image-side surface thereof is concave. The fourth lens **4024** has a positive refractive power, and an object-side surface thereof is convex and an image-side surface thereof is concave. The fifth lens **5024** has a positive refractive power, and an object-side surface thereof is concave and an image-side surface thereof is convex. The sixth lens **6024** has a positive refractive power, and an object-side surface thereof is concave and an image-side surface thereof is convex. In addition, at least one inflection point is formed on either one or both of the object-side surface and the image-side surface of the sixth lens **6024**. The seventh lens **7024** has a negative refractive power, and an object-side surface thereof is concave and an image-side surface thereof is concave. In addition, no inflection point is formed on the object-side

equal to TTL-SL and can be calculated from the values of TTL and SL for Example 24 listed in Table 57 that appears later in this application.

Table 47 below shows physical properties of the lenses and other elements of the optical imaging system of FIG. **47**, and Table 48 below shows aspherical surface coefficients of the lenses of FIG. **47**.

TABLE 47

Surface No.	Element	Radius of Curvature	Thickness/Distance	Index of Refraction	Abbe Number	Effective Aperture Radius
S1	First	1.8263	0.7034	1.546	56.114	1.290
S2	Lens	7.7056	0.1540			1.215
S3	(Stop)	4.6213	0.2200	1.679	19.236	1.127
S4	Second Lens	2.7291	0.3146			1.109
S5	Third	6.6824	0.4391	1.546	56.114	1.151
S6	Lens	11.7185	0.1811			1.250
S7	Fourth	6.8604	0.2500	1.679	19.236	1.259
S8	Lens	7.4620	0.4065			1.408
S9	Fifth	-9.8497	0.5939	1.546	56.114	1.604
S10	Lens	-1.8870	0.0250			1.970
S11	Sixth	-41.8807	0.3701	1.546	56.114	2.299
S12	Lens	-3.7454	0.2569			2.568
S13	Seventh	-2.0634	0.3200	1.546	56.114	2.855
S14	Lens	2.6116	0.1554			3.055
S15	Filter	Infinity	0.2100	1.518	64.197	3.346
S16		Infinity	0.6400			3.410
S17	Imaging Plane	Infinity	0.0100			3.730

TABLE 48

	K	A	B	C	D	E	F	G	H	J
S1	-1.0945	0.0136	0.0506	-0.1839	0.416	-0.5839	0.51	-0.2705	0.0795	-0.01
S2	3.251	-0.0482	0.0508	-0.085	0.2198	-0.436	0.5133	-0.3477	0.1258	-0.0189

TABLE 48-continued

	K	A	B	C	D	E	F	G	H	J
S3	-13.699	-0.1155	0.1942	-0.4376	1.335	-2.7707	3.4839	-2.5718	1.0289	-0.1723
S4	-4.0179	-0.0945	0.2406	-0.7546	2.4023	-4.9111	6.1463	-4.5679	1.8552	-0.3168
S5	-6.6783	-0.0675	0.1229	-0.5308	1.3347	-2.1668	2.2329	-1.4059	0.4923	-0.0729
S6	2.6687	-0.1089	0.0811	-0.1248	0.0166	0.1977	-0.3307	0.2573	-0.1017	0.0162
S7	7.0258	-0.2027	0.0564	-0.0521	0.0446	-0.0418	0.0403	-0.0212	0.001	0.0016
S8	-10.8	-0.1484	0.0297	-0.0692	0.1666	-0.2292	0.2033	-0.1109	0.0326	-0.0038
S9	-26.465	0.0072	-0.0015	-0.1473	0.2748	-0.3047	0.2171	-0.0939	0.0219	-0.0021
S10	-1.4915	0.1141	-0.2124	0.1883	-0.1127	0.0475	-0.0129	0.0021	-0.0002	6E-06
S11	-6.8308	0.0507	-0.1087	0.0643	-0.0416	0.0215	-0.0064	0.0011	-9E-05	3E-06
S12	-10.262	0.0544	0.062	-0.1082	0.0705	-0.0254	0.0054	-0.0007	4E-05	-1E-06
S13	-6.0066	0.0037	-0.0456	0.0731	-0.0405	0.0115	-0.0019	0.0002	-9E-06	2E-07
S14	-0.8095	-0.1128	0.0401	-0.0105	0.0011	0.0002	-7E-05	8E-06	-5E-07	1E-08

15

Twenty-Fifth Example

FIG. 49 is a view illustrating a twenty-fifth example of an optical imaging system, and FIG. 50 illustrates aberration curves of the optical imaging system of FIG. 49.

An optical imaging system 25 includes a first lens 1025, a second lens 2025, a third lens 3025, a fourth lens 4025, a fifth lens 5025, a sixth lens 6025, and a seventh lens 7025.

The first lens 1025 has a positive refractive power, and an object-side surface thereof is convex and an image-side surface thereof is concave. The second lens 2025 has a negative refractive power, and an object-side surface thereof is convex and an image-side surface thereof is concave. The third lens 3025 has a positive refractive power, and an object-side surface thereof is concave and an image-side surface thereof is convex. The fourth lens 4025 has a negative refractive power, and an object-side surface thereof is convex and an image-side surface thereof is concave. The fifth lens 5025 has a positive refractive power, and an object-side surface thereof is concave and an image-side surface thereof is convex. The sixth lens 6025 has a positive refractive power, and an object-side surface thereof is concave and an image-side surface thereof is convex. In addition, at least one inflection point is formed on either one or both of the object-side surface and the image-side surface of the sixth lens 6025. The seventh lens 7025 has a negative refractive power, and an object-side surface thereof is concave and an image-side surface thereof is concave. In addition, no inflection point is formed on the object-side surface of the seventh lens 7025, and one inflection point is formed on the image-side surface of the seventh lens 7025.

The optical imaging system 25 further includes a stop, a filter 8025, and an image sensor 9025. The stop is disposed between the second lens 2025 and the third lens 3025 to adjust an amount of light incident on the image sensor 9025. The filter 8025 is disposed between the seventh lens 7025 and the image sensor 9025 to block infrared rays. The image

sensor 9025 forms an imaging plane on which an image of a subject is formed. Although not illustrated in FIG. 49, the stop is disposed at a distance of 0.8722 mm from the object-side surface of the first lens 1025 toward the imaging plane of the optical imaging system 25. This distance is equal to TTL-SL and can be calculated from the values of TTL and SL for Example 25 listed in Table 57 that appears later in this application.

Table 49 below shows physical properties of the lenses and other elements of the optical imaging system of FIG. 49, and Table 50 below shows aspherical surface coefficients of the lenses of FIG. 49.

TABLE 49

Surface No.	Element	Radius of Curvature	Thickness/Distance	Index of Refraction	Abbe Number	Effective Aperture Radius
S1	First Lens	1.7603	0.6172	1.546	56.114	1.100
S2	Second Lens	14.1233	0.0250	1.667	20.353	1.040
S3	(Stop)	5.8341	0.2300	1.667	20.353	1.011
S4	Third Lens	3.1227	0.3733	1.546	56.114	0.919
S5	Fourth Lens	-49.9417	0.3799	1.546	56.114	0.995
S6	Fifth Lens	-15.1870	0.1809	1.667	20.353	1.096
S7	Sixth Lens	23.3680	0.3032	1.667	20.353	1.124
S8	Seventh Lens	12.2098	0.3354	1.546	56.114	1.309
S9	Filter	-4.3948	0.4729	1.546	56.114	1.471
S10	Image Sensor	-1.5983	0.0250	1.546	56.114	1.698
S11	Filter	-6.0815	0.5447	1.546	56.114	1.822
S12	Image Sensor	-3.0145	0.2724	1.546	56.114	2.192
S13	Filter	-6.1494	0.4224	1.546	56.114	2.462
S14	Image Sensor	1.6367	0.1933	1.518	64.197	2.880
S15	Filter	Infinity	0.2100	1.518	64.197	3.223
S16	Image Sensor	Infinity	0.6445	1.518	64.197	3.300
S17	Imaging Plane	Infinity	0.0099	1.518	64.197	3.728

TABLE 50

	K	A	B	C	D	E	F	G	H	J
S1	-1.0054	0.0225	0.0222	-0.0696	0.1604	-0.2238	0.1806	-0.0791	0.0141	0
S2	-1.5097	-0.1275	0.3975	-0.6982	0.6801	-0.322	0.0288	0.029	-0.0076	0
S3	6.0294	-0.163	0.4504	-0.8514	1.0525	-0.8203	0.4235	-0.138	0.0213	0
S4	-0.8846	-0.0449	0.0393	0.1574	-0.6934	1.3171	-1.3069	0.6799	-0.143	0
S5	0	-0.0513	-0.0193	-0.016	0.0043	0.0034	-0.0155	0.0319	-0.0128	0
S6	0	-0.1089	-0.0569	0.3576	-0.9255	1.1947	-0.8604	0.3322	-0.0547	0
S7	-7.5	-0.2139	-0.0107	0.1788	-0.1827	-0.1159	0.3046	-0.1897	0.0405	0
S8	-43.341	-0.1402	-0.061	0.2777	-0.4123	0.3523	-0.1857	0.0564	-0.0071	0
S9	-35.081	-0.0602	0.0736	-0.1046	0.1084	-0.0726	0.0255	-0.0041	0.0002	0
S10	-1.5734	0.1621	-0.2197	0.1896	-0.107	0.0396	-0.0091	0.0011	-6E-05	0
S11	0.5153	0.2137	-0.3167	0.2399	-0.1217	0.0384	-0.0069	0.0007	-3E-05	0

TABLE 50-continued

	K	A	B	C	D	E	F	G	H	J
S12	-1.1466	0.1967	-0.2565	0.1542	-0.0532	0.0115	-0.0015	0.0001	-4E-06	0
S13	-0.9056	-0.0077	-0.2094	0.1883	-0.0749	0.0167	-0.0022	0.0002	-5E-06	0
S14	-1.2797	-0.2192	0.1006	-0.0338	0.0088	-0.0018	0.0003	-2E-05	1E-06	-3E-08

Twenty-Sixth Example

FIG. 51 is a view illustrating a twenty-sixth example of an optical imaging system, and FIG. 52 illustrates aberration curves of the optical imaging system of FIG. 51.

An optical imaging system 26 includes a first lens 1026, a second lens 2026, a third lens 3026, a fourth lens 4026, a fifth lens 5026, a sixth lens 6026, and a seventh lens 7026.

The first lens 1026 has a positive refractive power, and an object-side surface thereof is convex and an image-side surface thereof is concave. The second lens 2026 has a negative refractive power, and an object-side surface thereof is convex and an image-side surface thereof is concave. The third lens 3026 has a positive refractive power, and an object-side surface thereof is concave and an image-side surface thereof is convex. The fourth lens 4026 has a positive refractive power, and an object-side surface thereof is convex and an image-side surface thereof is concave. The fifth lens 5026 has a negative refractive power, and an object-side surface thereof is convex and an image-side surface thereof is concave. The sixth lens 6026 has a positive refractive power, and an object-side surface thereof is convex and an image-side surface thereof is concave. In addition, at least one inflection point is formed on either one or both of the object-side surface and the image-side surface of the sixth lens 6026. The seventh lens 7026 has a positive refractive power, and an object-side surface thereof is convex and an image-side surface thereof is concave. In addition, two inflection points are formed on the object-side surface of the seventh lens 7026, and one inflection point is formed on the image-side surface of the seventh lens 7026.

The optical imaging system 26 further includes a stop, a filter 8026, and an image sensor 9026. The stop is disposed between the second lens 2026 and the third lens 3026 to adjust an amount of light incident on the image sensor 9026. The filter 8026 is disposed between the seventh lens 7026

and the image sensor 9026 to block infrared rays. The image sensor 9026 forms an imaging plane on which an image of a subject is formed. Although not illustrated in FIG. 51, the stop is disposed at a distance of 0.8664 mm from the object-side surface of the first lens 1026 toward the imaging plane of the optical imaging system 26. This distance is equal to TTL-SL and can be calculated from the values of TTL and SL for Example 26 listed in Table 57 that appears later in this application.

Table 51 below shows physical properties of the lenses and other elements of the optical imaging system of FIG. 51, and Table 52 below shows aspherical surface coefficients of the lenses of FIG. 51.

TABLE 51

Surface No.	Element	Radius of Curvature	Thickness/Distance	Index of Refraction	Abbe Number	Effective Aperture Radius
S1	First	1.8830	0.5872	1.546	56.114	1.050
S2	Lens	18.0733	0.0492			0.962
S3	Second	4.5995	0.2300	1.667	20.353	0.934
S4	Lens					
S4	(Stop)	2.5464	0.3929			0.837
S5	Third	-21.7546	0.2745	1.546	56.114	1.100
S6	Lens	-13.5144	0.0611			1.106
S7	Fourth	25.3349	0.2655	1.546	56.114	1.200
S8	Lens	25.3360	0.3710			1.285
S9	Fifth	9.4682	0.3930	1.656	21.525	1.500
S10	Lens	5.1029	0.3790			1.754
S11	Sixth	6.4162	0.8885	1.546	56.114	2.041
S12	Lens	6.3521	0.0460			2.631
S13	Seventh	1.9665	0.8854	1.536	55.656	3.050
S14	Lens	1.7699	0.3098			3.456
S15	Filter	Infinity	0.2100	1.518	64.197	3.768
S16		Infinity	0.6537			3.829
S17	Imaging Plane	Infinity	-0.0037			4.129

TABLE 52

	K	A	B	C	D	E	F	G	H	J
S1	-0.1525	0.0035	0.0054	-0.0238	0.0587	-0.0925	0.0808	-0.0376	0.0069	0
S2	-36.188	-0.0554	0.191	-0.4954	0.9092	-1.1194	0.849	-0.3546	0.0617	0
S3	-0.1164	-0.0883	0.2264	-0.5273	0.9947	-1.274	1.0104	-0.4343	0.076	0
S4	0.3326	-0.0462	0.097	-0.2316	0.5455	-0.848	0.7854	-0.3759	0.0708	0
S5	51.758	-0.0119	-0.0911	0.3617	-0.9067	1.3845	-1.3014	0.6835	-0.1493	0
S6	42.164	0.0924	-0.5269	1.3558	-2.2584	2.5093	-1.8107	0.7611	-0.139	0
S7	-4.7579	0.1336	-0.5938	1.261	-1.8115	1.7924	-1.1666	0.4427	-0.0728	0
S8	-3.4393	0.0471	-0.1842	0.2886	-0.3575	0.3273	-0.1971	0.067	-0.0093	0
S9	-8.5449	-0.0502	-0.0588	0.1599	-0.2027	0.1398	-0.0542	0.0105	-0.0007	0
S10	-18.064	-0.044	-0.0734	0.1425	-0.1303	0.0691	-0.0217	0.0038	-0.0003	0
S11	-4.6497	0.0633	-0.1193	0.0882	-0.0426	0.0135	-0.0028	0.0004	-2E-05	0
S12	-50	0.034	-0.0497	0.0246	-0.0072	0.0013	-0.0001	7E-06	-2E-07	0

TABLE 52-continued

	K	A	B	C	D	E	F	G	H	J
S13	-2.4291	-0.1201	0.0167	0.0022	-0.0009	0.0001	-6E-06	1E-07	9E-10	0
S14	-1.0032	-0.1111	0.0248	-0.0032	-0.0001	0.0001	-2E-05	2E-06	-8E-08	1E-09

Twenty-Seventh Example

FIG. 53 is a view illustrating a twenty-seventh example of an optical imaging system, and FIG. 54 illustrates aberration curves of the optical imaging system of FIG. 53.

An optical imaging system 27 includes a first lens 1027, a second lens 2027, a third lens 3027, a fourth lens 4027, a fifth lens 5027, a sixth lens 6027, and a seventh lens 7027.

The first lens 1027 has a positive refractive power, and an object-side surface thereof is convex and an image-side surface thereof is concave. The second lens 2027 has a negative refractive power, and an object-side surface thereof is convex and an image-side surface thereof is concave. The third lens 3027 has a positive refractive power, and an object-side surface thereof is concave and an image-side surface thereof is convex. The fourth lens 4027 has a positive refractive power, and an object-side surface thereof is convex and an image-side surface thereof is concave. The fifth lens 5027 has a negative refractive power, and an object-side surface thereof is convex and an image-side surface thereof is concave. The sixth lens 6027 has a positive refractive power, and an object-side surface thereof is convex and an image-side surface thereof is concave. In addition, at least one inflection point is formed on either one or both of the object-side surface and the image-side surface of the sixth lens 6027. The seventh lens 7027 has a positive refractive power, and an object-side surface thereof is convex and an image-side surface thereof is concave. In addition, two inflection points are formed on the object-side surface of the seventh lens 7027, and one inflection point is formed on the image-side surface of the seventh lens 7027.

The optical imaging system 27 further includes a stop, a filter 8027, and an image sensor 9027. The stop is disposed between the second lens 2027 and the third lens 3027 to adjust an amount of light incident on the image sensor 9027. The filter 8027 is disposed between the seventh lens 7027 and the image sensor 9027 to block infrared rays. The image

equal to TTL-SL and can be calculated from the values of TTL and SL for Example 27 listed in Table 57 that appears later in this application.

Table 53 below shows physical properties of the lenses and other elements of the optical imaging system of FIG. 53, and Table 54 below shows aspherical surface coefficients of the lenses of FIG. 53.

TABLE 53

Sur- face No.	Element	Radius of Curvature	Thick- ness/ Distance	Index of Refraction	Abbe Number	Effective Aperture Radius
S1	First	1.8987	0.6486	1.546	56.114	1.260
S2	Lens	7.3568	0.0250			1.216
S3	Second	3.8789	0.2300	1.667	20.353	1.161
S4	Lens	2.7620	0.3408			1.053
	(Stop)					
S5	Third	-50.1242	0.2819	1.546	56.114	1.120
S6	Lens	-14.9889	0.0597			1.158
S7	Fourth	12.0498	0.2698	1.546	56.114	1.220
S8	Lens	12.5657	0.2919			1.320
S9	Fifth	9.5926	0.3500	1.667	20.353	1.520
S10	Lens	5.2748	0.3344			1.762
S11	Sixth	6.8735	0.8484	1.546	56.114	2.052
S12	Lens	7.4933	0.0591			2.641
S13	Seventh	2.0337	0.8836	1.536	55.656	3.070
S14	Lens	1.8436	0.3048			3.425
S15	Filter	Infinity	0.2100	1.518	64.197	3.764
S16		Infinity	0.6441			3.825
S17	Imaging Plane	Infinity	0.0150			4.134

TABLE 54

	K	A	B	C	D	E	F	G	H	J
S1	-0.1061	-0.0082	0.0469	-0.0925	0.0811	-0.0129	-0.032	0.0224	-0.0047	0
S2	-36.188	-0.0502	0.1624	-0.4029	0.6931	-0.7643	0.5021	-0.1789	0.0264	0
S3	0.0036	-0.0795	0.2057	-0.548	1.0742	-1.291	0.9097	-0.3412	0.052	0
S4	0.4038	-0.0325	0.0884	-0.3009	0.7004	-0.9194	0.6738	-0.2424	0.0308	0
S5	51.758	0.0055	-0.1746	0.5018	-0.9395	1.1442	-0.9144	0.4407	-0.0937	0
S6	42.164	0.0953	-0.4992	1.0397	-1.2284	0.8169	-0.2802	0.0384	4E-06	0
S7	-4.7579	0.1185	-0.4938	0.8554	-0.8643	0.5167	-0.185	0.0417	-0.0054	0
S8	-3.4393	0.0492	-0.194	0.3147	-0.3773	0.3249	-0.1878	0.063	-0.0088	0
S9	-8.5449	-0.0638	0.0289	-0.0884	0.1649	-0.171	0.0983	-0.0306	0.0041	0
S10	-18.064	-0.0543	-0.0172	0.0321	-0.0179	0.004	5E-06	-0.0001	8E-06	0
S11	-4.6497	0.0535	-0.0909	0.0613	-0.0311	0.011	-0.0026	0.0004	-2E-05	0
S12	-50	0.0103	-0.0176	0.0057	-0.0015	0.0003	-4E-05	2E-06	-6E-08	0
S13	-2.606	-0.1177	0.0192	-0.0004	-1E-04	-1E-05	4E-06	-4E-07	9E-09	0
S14	-1.0102	-0.0979	0.0187	-0.0024	0.0001	2E-05	-6E-06	6E-07	-3E-08	6E-10

sensor 9027 forms an imaging plane on which an image of a subject is formed. Although not illustrated in FIG. 53, the stop is disposed at a distance of 0.9037 mm from the object-side surface of the first lens 1027 toward the imaging plane of the optical imaging system 27. This distance is

Twenty-Eighth Example

FIG. 55 is a view illustrating a twenty-eighth example of an optical imaging system, and FIG. 56 illustrates aberration curves of the optical imaging system of FIG. 55.

63

An optical imaging system **28** includes a first lens **1028**, a second lens **2028**, a third lens **3028**, a fourth lens **4028**, a fifth lens **5028**, a sixth lens **6028**, and a seventh lens **7028**.

The first lens **1028** has a positive refractive power, and an object-side surface thereof is convex and an image-side surface thereof is concave. The second lens **2028** has a positive refractive power, and an object-side surface thereof is convex and an image-side surface thereof is concave. The third lens **3028** has a negative refractive power, and an object-side surface thereof is convex and an image-side surface thereof is concave. The fourth lens **4028** has a positive refractive power, and an object-side surface thereof is convex and an image-side surface thereof is concave. The fifth lens **5028** has a negative refractive power, and an object-side surface thereof is convex and an image-side surface thereof is concave. The sixth lens **6028** has a positive refractive power, and an object-side surface thereof is convex and an image-side surface thereof is concave. In addition, at least one inflection point is formed on either one or both of the object-side surface and the image-side surface of the sixth lens **6028**. The seventh lens **7028** has a negative refractive power, and an object-side surface thereof is convex and an image-side surface thereof is concave. In addition,

64

TABLE 55

Surface No.	Element	Radius of Curvature	Thickness/Distance	Index of Refraction	Abbe Number	Effective Aperture Radius
S1	First	2.2813	0.4941	1.546	56.114	1.640
S2	Lens	2.7190	0.1308			1.629
S3	Second	2.7090	0.6000	1.546	56.114	1.595
S4	Lens	37.2451	0.0250			1.593
S5	(Stop)	11.0960	0.2300	1.679	19.236	1.522
S6	Third Lens	4.3260	0.4820			1.450
S7	Fourth	8.7091	0.3517	1.656	21.525	1.514
S8	Lens	14.9889	0.4926			1.555
S9	Fifth	5.3406	0.4257	1.679	19.236	1.840
S10	Lens	2.9721	0.1952			2.415
S11	Sixth	2.1211	0.5425	1.546	56.114	2.362
S12	Lens	4.9818	0.4212			2.717
S13	Seventh	2.4999	0.5046	1.546	56.114	3.169
S14	Lens	1.4794	0.2230			3.372
S15	Filter	Infinity	0.2100	1.518	64.197	3.779
S16		Infinity	0.6566			3.848
S17	Imaging Plane	Infinity	0.0150			4.210

TABLE 56

	K	A	B	C	D	E	F	G	H	J
S1	-0.9867	-0.0114	0.0111	-0.0538	0.0917	-0.0925	0.0542	-0.0183	0.0033	-0.0003
S2	-12.035	0.0479	-0.173	0.2637	-0.3194	0.2597	-0.1301	0.0386	-0.0062	0.0004
S3	-0.9455	-0.0107	-0.0528	0.1054	-0.1922	0.2187	-0.1388	0.0499	-0.0096	0.0008
S4	3.0384	-0.0418	0.2162	-0.5714	0.8143	-0.6941	0.3642	-0.1154	0.0202	-0.0015
S5	10.164	-0.0842	0.2583	-0.5961	0.8439	-0.7413	0.4043	-0.1328	0.0241	-0.0018
S6	2.0809	-0.0648	0.1424	-0.2905	0.4095	-0.3776	0.2224	-0.0802	0.0163	-0.0014
S7	-13.097	-0.0215	-0.0518	0.145	-0.2583	0.2777	-0.1843	0.0733	-0.0157	0.0014
S8	5.8592	-0.0435	0.0377	-0.0856	0.1074	-0.0887	0.0479	-0.0161	0.0031	-0.0003
S9	-43.521	-0.0279	0.0228	0.0104	-0.0468	0.0468	-0.0253	0.0078	-0.0013	9E-05
S10	-17.628	-0.0671	0.0426	-0.0048	-0.0103	0.0068	-0.0022	0.0004	-4E-05	1E-06
S11	-9.8081	0.0426	-0.1025	0.0919	-0.0514	0.0177	-0.0039	0.0006	-5E-05	2E-06
S12	-0.0695	0.0048	-0.0496	0.0379	-0.0164	0.004	-0.0005	4E-05	-8E-07	-1E-08
S13	-0.6908	-0.2261	0.0409	0.0129	-0.0077	0.0017	-0.0002	1E-05	-6E-07	1E-08
S14	-1.419	-0.2123	0.0904	-0.0281	0.0063	-0.001	9E-05	-6E-06	2E-07	-2E-09

tion, one inflection point is formed on each of the object-side surface and the image-side surface of the seventh lens **7028**.

The optical imaging system **28** further includes a stop, a filter **8028**, and an image sensor **9028**. The stop is disposed between the second lens **2028** and the third lens **3028** to adjust an amount of light incident on the image sensor **9028**. The filter **8028** is disposed between the seventh lens **7028** and the image sensor **9028** to block infrared rays. The image sensor **9028** forms an imaging plane on which an image of a subject is formed. Although not illustrated in FIG. **55**, the stop is disposed at a distance of 1.2500 mm from the object-side surface of the first lens **1028** toward the imaging plane of the optical imaging system **28**. This distance is equal to TTL-SL and can be calculated from the values of TTL and SL for Example 28 listed in Table 57 that appears later in this application.

Table 55 below shows physical properties of the lenses and other elements of the optical imaging system of FIG. **55**, and Table 56 below shows aspherical surface coefficients of the lenses of FIG. **55**.

Table 57 below shows an overall focal length f of the optical imaging system, an overall length TTL of the optical imaging system (a distance from the object-side surface of the first lens to the imaging plane), a distance SL from the stop to the imaging plane, an f-number (F No.) of the optical imaging system (the overall focal length f of the optical imaging system divided by the diameter of an entrance pupil of the optical imaging system, where both f and the diameter of the entrance pupil are expressed in mm), an image height (IMG HT) on the imaging plane (one-half of a diagonal length of the imaging plane), and a field of view (FOV) of the optical imaging system for each of Examples 1-28 described herein. The values of f , TTL, SL, and IMG HT are expressed in mm. The values of F No. are dimensionless values. The values of FOV are expressed in degrees.

TABLE 57

Example	f	TTL	SL	F No.	IMG HT	FOV	f134567
1	4.8480	6.000	5.0965	1.540	4.000	77.800	3.4441
2	4.2829	5.1899	3.9385	1.5853	3.6900	79.815	-23.2030
3	4.7800	5.8272	4.4022	1.5729	4.0500	79.019	-42.8744
4	3.9500	4.8189	3.6503	1.5808	3.2500	77.470	-30.5480
5	4.3500	5.3000	4.9170	1.5800	3.3844	79.580	-5.2273
6	4.2800	5.1000	4.3688	1.7100	3.5352	77.840	2.7518
7	4.4011	5.3000	4.1423	1.6897	3.7280	79.310	-26.4128
8	4.5110	5.4999	4.4199	1.6585	3.7280	77.849	392.6438
9	4.5442	5.5000	4.4233	1.6724	3.7280	77.539	-58.4566
10	4.8227	5.8648	4.6866	1.6639	3.7280	73.384	89.9938
11	4.5369	5.5000	4.2704	1.5688	3.7280	77.565	-21.5648
12	4.8309	5.9552	4.7759	1.6624	4.1280	79.742	-11.9581
13	5.0858	5.9999	4.7947	1.5909	4.1280	76.863	-8.3987
14	4.4468	5.1439	4.8939	2.0717	3.5280	75.627	2.5748
15	4.4000	5.2000		1.8078	3.2610	72.552	3.0701
16	3.9935	5.1246	4.4837	1.5723	3.2610	77.383	3.8824
17	3.9200	4.7000	4.0189	1.8300	3.2610	78.330	2.7493
18	4.0052	4.9400	3.8888	1.5800	3.2260	76.500	6.5989
19	4.3329	5.3200	4.9460	1.4980	3.7520	80.300	-5.0314
20	4.7371	5.8000	4.7399	1.5686	4.2500	82.209	3.7697
21	4.5877	5.6173	4.4893	1.6867	3.7280	76.901	-157.3713
22	4.4980	5.5000	4.2749	1.6297	3.7280	78.012	-9.9003
23	4.5861	5.4613	4.5098	1.7914	3.7280	76.963	3.1230
24	4.3158	5.2500	4.3926	1.6913	3.7280	80.429	3.0710
25	4.3017	5.2400	4.3678	1.9545	3.7280	80.465	3.0059
26	4.9659	5.9933	5.1269	2.3647	4.1280	78.448	3.1668
27	4.6674	5.7971	4.8934	1.8451	4.1280	81.802	3.6413
28	4.8700	6.0000	4.7500	1.4848	4.2000	80.288	-23.7892

Table 58 below shows in mm a focal length f1 of the first lens, a focal length f2 of the second lens, a focal length f3 of the third lens, a focal length f4 of the fourth lens, a focal length f5 of the fifth lens, a focal length f6 of the sixth lens, and a focal length f7 of the seventh lens for each of Examples 1-28 described herein.

Table 59 below shows in mm a thickness (DedgeT) of an edge of the first lens, a thickness (L2edgeT) of an edge of the second lens, a thickness (L3edgeT) of an edge of the third lens, a thickness (L4edgeT) of an edge of the fourth lens, a thickness (L5edgeT) of an edge of the fifth lens, a thickness (L6edgeT) of an edge of the sixth lens, and a thickness (L7edgeT) of an edge of the seventh lens for each of Examples 1-28 described herein.

TABLE 58

Example	f1	f2	f3	f4	f5	f6	f7
1	4.699	-11.772	21.070	-38.885	-12.922	2.771	-2.453
2	9.5890	4.5406	-6.9872	17555492	558.7000	-30.322	1998.195
3	10.0345	5.2922	-7.6128	22346862	86.5836	-27.728	146.074
4	8.4094	4.3550	-6.5204	-4512	74.3686	-22.452	1842.731
5	-64.2326	3.2480	-7.4275	-43.7223	52.4247	3.010	-2.424
6	3.5960	-7.3490	-1245.24	15.6567	-19.7232	2.662	-2.171
7	9.9516	4.9854	-9.0419	-60.9593	28.4615	-19.130	-36.205
8	12.2172	6.0167	-9.9247	25.3582	28.7232	-32.884	-16.737
9	13.4191	5.6271	-8.9208	16.1417	-36.7578	29.873	-12.281
10	13.6636	6.5561	-11.4351	32.2946	28.3279	-36.885	-22.967
11	17.0122	4.9962	-9.0344	25.7533	24.3015	-79.899	-10.773
12	32.0696	4.9582	-9.5104	22.5720	16.1804	-12.867	-20.135
13	43.5223	4.4621	-8.8732	52.4923	16.2883	-17.315	-19.385
14	3.6264	-6.9779	10.5508	125.3810	-28.1554	-367.720	-9.031
15	4.2900	-10.6063	30.9779	14.8711	-21.1331	3.784	-2.465
16	5.6767	-73.5511	-122.7160	15.5097	207.3750	3.799	-2.466
17	3.5400	-8.7600	-87.3600	14.1800	-64.1800	-799.990	-18.040
18	5.0178	11.6357	-8.1681	-18.7682	18.1322	2.601	-2.226
19	-31.5304	3.1365	-7.5452	-130.0329	80.8864	2.966	-2.423
20	5.1067	-17.5830	27.4583	-30.2565	-75.8106	2.526	-2.062
21	14.2697	5.4868	-9.0060	21.0725	-18.2040	43.002	92.362
22	20.3702	4.0105	-7.6691	107.4534	-23.0047	189.703	54.850
23	3.8083	-9.4079	-530.7502	22.8366	-27.1051	-22.324	66.015
24	4.2066	-10.3310	27.6314	107.6478	4.1658	7.509	-2.062
25	3.6197	-10.4284	39.8209	-38.7622	4.3417	10.303	-2.323
26	3.8015	-8.9549	64.5946	12384.8	-17.5030	299.093	57.797
27	4.4990	-15.6740	39.0579	453.7793	-18.1602	102.612	59.134
28	18.5366	5.3131	-10.5800	30.6731	-10.6364	6.334	-8.036

TABLE 59

Example	L1edgeT	L2edgeT	L3edgeT	L4edgeT	L5edgeT	L6edgeT	L7edgeT
1	0.2527	0.3544	0.2546	0.3479	0.2843	0.2558	0.8308
2	0.2513	0.2829	0.3599	0.2195	0.2899	0.3277	0.3914
3	0.2822	0.3127	0.4160	0.2370	0.3248	0.3709	0.3823
4	0.2327	0.2588	0.3335	0.2027	0.2718	0.3298	0.3765
5	0.2200	0.2700	0.3480	0.2240	0.2590	0.2690	0.4370
6	0.2216	0.3773	0.2347	0.2401	0.1894	0.2600	0.3234
7	0.2568	0.2552	0.3401	0.2756	0.3650	0.3065	0.2776
8	0.2535	0.2550	0.4864	0.2519	0.3609	0.4901	0.4086
9	0.2497	0.2500	0.4399	0.2704	0.3183	0.6519	0.2941
10	0.2855	0.3362	0.4980	0.2610	0.4273	0.4966	0.4889
11	0.2582	0.2578	0.4040	0.2530	0.4107	0.2818	0.4636
12	0.2479	0.3333	0.3826	0.3612	0.5824	0.3553	0.6406
13	0.2542	0.1246	0.4252	0.2768	0.3797	0.4611	0.3277
14	0.2688	0.3078	0.1901	0.2300	0.4099	0.7139	0.3000
15	0.2048	0.4069	0.2010	0.3332	0.2778	0.3483	0.8151
16	0.2180	0.3468	0.2110	0.2593	0.2768	0.2512	0.9497
17	0.1000	0.2800	0.1200	0.4200	0.1600	0.4100	0.5800
18	0.2320	0.2180	0.3500	0.2220	0.2410	0.3730	0.3970
19	0.2203	0.2484	0.3500	0.2373	0.2517	0.2418	0.5401
20	0.4351	0.3299	0.2145	0.3306	0.1429	0.2681	0.5558
21	0.2502	0.3421	0.3843	0.4086	0.2945	0.7273	0.2827
22	0.2675	0.3957	0.3836	0.4004	0.2278	0.5887	0.3421
23	0.2307	0.2892	0.2545	0.2544	0.3605	0.4762	0.6576
24	0.2501	0.3506	0.2323	0.3110	0.3641	0.3267	0.3719
25	0.2520	0.2935	0.2377	0.3745	0.2580	0.4152	0.6857
26	0.2927	0.2979	0.2516	0.2513	0.4092	0.7155	0.6778
27	0.2463	0.2800	0.2542	0.2728	0.3562	0.6300	0.6917
28	0.2515	0.1596	0.4288	0.3024	0.4301	0.3912	0.4326

Table 60 below shows in mm a sag (L5S1 sag) of an object-side surface of the fifth lens, a sag (L5S2 sag) of an image-side surface of the fifth lens, a thickness (Yc71P1) of the seventh lens at a first inflection point on the object-side surface of the seventh lens, a thickness (Yc71P2) of the seventh lens at a second inflection point on the object-side surface of the seventh lens, a thickness (Yc72P1) of the seventh lens at a first inflection point on the image-side surface of the seventh lens, and a thickness (Yc72P2) of the seventh lens at a second inflection point on the image-side surface of the seventh lens for each of Examples 1-28 described herein.

TABLE 60

Example	L5S1 sag	L5S2 sag	Yc71P1	Yc71P2	Yc72P1	Yc72P2
1	-0.4639	-0.4961	1.3100	—	0.9900	—
2	0.1069	0.1580	0.5970	0.6980	0.6920	—
3	0.1973	0.1988	0.6780	0.8030	0.7950	—
4	0.2004	0.2021	0.5680	0.6700	0.6670	—
5	0.1154	0.1393	0.9300	—	0.8110	—
6	-0.4658	-0.5261	2.9330	—	4.1420	—
7	0.2103	0.2454	0.5690	0.6410	0.6700	—
8	0.1024	0.1416	0.5620	—	0.6860	—
9	0.1850	0.2667	0.5270	0.4850	0.6470	—
10	0.0544	0.0531	0.6070	—	0.7170	—
11	0.1496	0.0888	0.5070	0.7380	0.6370	—
12	0.1290	0.0520	0.6280	0.9230	0.7900	—
13	0.0698	0.0604	0.6330	0.5190	0.7380	—
14	-0.2605	-0.2625	0.4730	—	0.6310	—
15	-0.4848	-0.4070	0.8900	—	0.9200	—
16	-0.4791	-0.4221	—	—	0.7810	—
17	-0.4400	-0.4500	0.7300	—	1.1200	—
18	-0.3405	-0.5395	0.8247	—	0.7357	—
19	0.2023	0.2006	0.9670	—	0.5350	0.9040
20	0.3540	0.4306	1.0040	—	0.5110	0.9130
21	0.2211	0.3179	0.5700	0.4520	0.6330	—
22	0.1756	0.3016	0.5950	—	0.6720	—
23	0.2805	0.2808	0.8830	0.9150	0.9880	—
24	0.4949	0.7331	—	—	0.7340	—
25	0.2760	0.5093	—	—	0.9680	—
26	0.0918	0.1026	0.9550	1.1030	1.1280	—

TABLE 60-continued

Example	L5S1 sag	L5S2 sag	Yc71P1	Yc71P2	Yc72P1	Yc72P2
27	0.1793	0.1731	0.9640	1.1140	1.1300	—
28	0.2606	0.2562	0.5870	—	0.7630	—

Table 61 below shows in mm an inner diameter of each of the first to seventh spacers for each of Examples 1-28 described herein. S1d is an inner diameter of the first spacer SP1, S2d is an inner diameter of the second spacer SP2, S3d is an inner diameter of the third spacer SP3, S4d is an inner diameter of the fourth spacer SP4, S5d is an inner diameter of the fifth spacer SP5, S6d is an inner diameter of the sixth spacer SP6, and S7d is an inner diameter of the seventh spacer SP7.

TABLE 61

Example	S1d	S2d	S3d	S4d	S5d	S6d	S7d
1	2.8400	2.5300	2.8300	3.2900	4.3400	6.3100	—
2	1.3500	1.2300	1.1400	1.5300	2.0700	2.7800	—
3	1.5000	1.3400	1.3200	1.7200	2.3100	3.0300	—
4	1.2400	1.1500	1.0300	1.4800	1.9000	2.4600	—
5	1.3400	1.2300	1.0300	1.5000	1.9800	2.6600	—
6	2.3100	2.1600	2.5400	2.9400	4.0600	4.8400	5.12
7	2.5800	2.4000	2.4900	2.9700	4.1600	4.8900	5.51
8	2.5900	2.5000	2.5300	2.9000	3.8000	4.9000	—
9	2.6500	2.4600	2.3900	2.9000	3.8000	5.1500	—
10	2.7700	2.6100	2.7900	3.1200	4.0300	4.8900	—
11	2.8100	2.6300	2.6500	3.1200	4.0300	4.9100	—
12	2.8000	2.6500	2.7300	3.5400	3.4200	4.4400	5.74
13	3.1700	3.0000	2.7900	3.0800	4.1800	5.4900	—
14	2.1200	2.1000	2.0400	2.1200	2.8100	4.6400	—
15	2.3200	2.3600	2.5600	2.9300	3.7000	4.3500	—
16	2.4100	2.3000	2.6600	3.0300	3.7600	—	—
17	2.1060	1.8860	2.0080	2.7000	3.0740	4.4840	—
18	2.4200	2.2300	2.0900	2.4700	3.2000	4.3300	—
19	2.8800	2.6300	2.2900	2.9300	4.3800	5.5100	—

portion of the rib of the first lens, L2rt is a thickness of a flat portion of the rib of the second lens, L3rt is a thickness of a flat portion of the rib of the third lens, L4rt is a thickness of a flat portion of the rib of the fourth lens, L5rt is a thickness of a flat portion of the rib of the fifth lens, L6rt is a thickness of a flat portion of the rib of the sixth lens, and L7rt is a thickness of a flat portion of the rib of the seventh lens.

TABLE 65

Example	L1rt	L2rt	L3rt	L4rt	L5rt	L6rt	L7rt
1	0.580	0.380	0.330	0.300	0.390	0.475	0.920
2	0.590	0.480	0.510	0.270	0.480	0.310	0.410
3	0.600	0.580	0.560	0.470	0.340	0.400	0.470
4	0.540	0.500	0.520	0.420	0.210	0.390	0.400

TABLE 65-continued

Example	L1rt	L2rt	L3rt	L4rt	L5rt	L6rt	L7rt
26	0.470	0.410	0.450	0.410	0.470	0.930	0.700
27	0.440	0.390	0.400	0.400	0.380	0.740	0.720
28	0.560	0.410	0.560	0.540	0.520	0.440	0.540

Table 66 below shows, for each of Examples 1-28 described herein, dimensionless values of each of the ratio L1w/L7w in Conditional Expressions 1 and 7, the ratio S6d/f in Conditional Expressions 2 and 8, the ratio L1TR/L7TR in Conditional Expressions 3 and 9, the ratio L1234TRavg/L7TR in Conditional Expressions 4 and 10, the ratio L12345TRavg/L7TR in Conditional Expressions 5 and 11, and the ratio |f134567-f|/f in Conditional Expressions 6 and 12. The dimensionless value of each of these ratios is obtained by dividing two values expressed in a same unit of measurement.

TABLE 66

Example	L1w/L7w	S6d/f	L1TR/L7TR	L1234TRavg/L7TR	L12345TRavg/L7TR	f134567-f /f
1	0.1945	1.3016	0.6321	0.703	0.747	0.290
2	0.3317	0.6491	0.6837	0.748	0.780	6.418
3	0.2946	0.6339	0.6740	0.730	0.760	9.970
4	0.3945	0.6228	0.7533	0.811	0.832	8.734
5	0.2109	0.6115	0.7089	0.759	0.790	2.202
6	0.2660	1.1308	0.6698	0.710	0.740	0.357
7	0.2141	1.1111	0.6101	0.645	0.674	7.001
8	0.2498	1.0862	0.6559	0.693	0.724	86.041
9	0.2883	1.1333	0.6426	0.678	0.712	13.864
10	0.2552	1.0140	0.6733	0.709	0.735	17.660
11	0.2595	1.0822	0.6743	0.710	0.736	5.753
12	0.1441	0.9191	0.6016	0.631	0.684	3.475
13	0.2662	1.0795	0.6700	0.701	0.727	2.651
14	0.2301	1.0434	0.5616	0.668	0.721	0.421
15	0.1550	0.9886	0.5892	0.710	0.727	0.302
16	0.1387		0.5953	0.682	0.731	0.028
17	0.1161	1.1439	0.5883	0.657	0.702	0.299
18	0.2254	1.0811	0.6528	0.719	0.755	0.648
19	0.1964	1.2717	0.6691	0.734	0.770	2.161
20	0.2983	1.0829	0.6784	0.742	0.776	0.204
21	0.2928	1.1487	0.6343	0.670	0.700	35.303
22	0.2512	1.0738	0.6337	0.669	0.702	3.201
23	0.1599	1.1208	0.5587	0.584	0.610	0.319
24	0.2471	1.2304	0.5700	0.599	0.633	0.288
25	0.1196	1.0600	0.5437	0.579	0.608	0.301
26	0.1031	1.0935	0.4950	0.525	0.550	0.362
27	0.1209	1.2170	0.5522	0.582	0.607	0.220
28	0.2240	1.1499	0.6212	0.652	0.684	5.885

TABLE 65-continued

Example	L1rt	L2rt	L3rt	L4rt	L5rt	L6rt	L7rt
5	0.390	0.440	0.470	0.360	0.420	0.380	0.470
6	0.435	0.430	0.360	0.215	0.320	0.330	0.405
7	0.550	0.380	0.580	0.410	0.500	0.320	0.530
8	0.490	0.390	0.680	0.360	0.630	0.490	0.480
9	0.520	0.420	0.520	0.410	0.610	0.700	0.370
10	0.490	0.470	0.710	0.470	0.560	0.500	0.550
11	0.560	0.430	0.560	0.510	0.400	0.350	0.550
12	0.490	0.530	0.520	0.370	0.620	0.520	0.690
13	0.600	0.440	0.600	0.460	0.580	0.600	0.440
14	0.482	0.395	0.316	0.328	0.422	0.885	0.409
15	0.431	0.556	0.361	0.429	0.380	0.380	0.667
16	0.431	0.457	0.361	0.364	0.380	0.334	0.729
17	0.326	0.433	0.265	0.472	0.156	0.520	0.641
18	0.440	0.330	0.300	0.260	0.425	0.500	0.518
19	0.540	0.480	0.460	0.250	0.555	0.395	0.688
20	0.620	0.400	0.270	0.430	0.300	0.520	0.760
21	0.480	0.490	0.480	0.500	0.470	0.830	0.320
22	0.480	0.560	0.580	0.470	0.340	0.620	0.440
23	0.510	0.250	0.320	0.320	0.510	0.530	0.720
24	0.510	0.450	0.340	0.430	0.410	0.410	0.420
25	0.400	0.420	0.370	0.500	0.320	0.460	0.720

FIGS. 57 and 58 are cross-sectional views illustrating examples of an optical imaging system and a lens barrel coupled to each other.

The examples of the optical imaging system 100 described in this application may include a self-alignment structure as illustrated in FIGS. 57 and 58.

In one example illustrated in FIG. 57, the optical imaging system 100 includes a self-alignment structure in which optical axes of four consecutive lenses 1000, 2000, 3000, and 4000 are aligned with an optical axis of the optical imaging system 100 by coupling the four lenses 1000, 2000, 3000, and 4000 to one another.

The first lens 1000 disposed closest to the object side of the optical imaging system 100 is disposed in contact with an inner surface of a lens barrel 200 to align the optical axis of the first lens 1000 with the optical axis of the optical imaging system 100, the second lens 2000 is coupled to the first lens 1000 to align the optical axis of the second lens 2000 with the optical axis of the optical imaging system 100, the third lens 3000 is coupled to the second lens 2000 to align the optical axis of the third lens 3000 with the optical

axis of the optical imaging system **100**, and the fourth lens **4000** is coupled to the third lens **3000** to align the optical axis of the fourth lens **4000** with the optical axis of the optical imaging system **100**. The second lens **2000** to the fourth lens **4000** may not be disposed in contact with the inner surface of the lens barrel **200**.

Although FIG. **57** illustrates that the first lens **1000** to the fourth lens **4000** are coupled to one another, the four consecutive lenses that are coupled to one another may be changed to the second lens **2000** to a fifth lens **5000**, or the third lens **3000** to a sixth lens **6000**, or the fourth lens **4000** to a seventh lens **7000**.

In another example illustrated in FIG. **58**, the optical imaging system **100** includes a self-alignment structure in which optical axes of five consecutive lenses **1000**, **2000**, **3000**, **4000**, and **5000** are aligned with an optical axis of the optical imaging system **100** by coupling the five lenses **1000**, **2000**, **3000**, **4000**, and **5000** to one another.

The first lens **1000** disposed closest to the object side of the optical imaging system **100** is disposed in contact with an inner surface of the lens barrel **200** to align the optical axis of the first lens **1000** with the optical axis of the optical imaging system **100**, the second lens **2000** is coupled to the first lens **1000** to align the optical axis of the second lens **2000** with the optical axis of the optical imaging system **100**, the third lens **3000** is coupled to the second lens **2000** to align the optical axis of the third lens **3000** with the optical axis of the optical imaging system **100**, the fourth lens **4000** is coupled to the third lens **3000** to align the optical axis of the fourth lens **4000** with the optical axis of the optical imaging system **100**, and the fifth lens **5000** is coupled to the fourth lens **4000** to align the optical axis of the fifth lens **5000** with the optical axis of the optical imaging system **100**. The second lens **2000** to the fifth lens **5000** may not be disposed in contact with the inner surface of the lens barrel **200**.

Although FIG. **58** illustrates that the first lens **1000** to the fifth lens **5000** are coupled to one another, the five consecutive lenses that are coupled to one another may be changed to the second lens **2000** to a sixth lens **6000**, or the third lens **3000** to a seventh lens **7000**.

FIG. **59** is a cross-sectional view illustrating an example of a seventh lens.

FIG. **59** illustrates the overall outer diameter ($L7TR$) of the seventh lens, the thickness ($L7rt$) of the flat portion of the rib of the seventh lens, the thickness ($L7edgeT$) of the edge of the seventh lens, the thickness ($Yc71P1$) of the seventh lens at the first inflection point on the object-side surface of the seventh lens, the thickness ($Yc71P2$) of the seventh lens at the second inflection point on the object-side surface of the seventh lens, and the thickness ($Yc72P1$) of the seventh lens at the first inflection point on the image-side surface of the seventh lens. Although not illustrated in FIG. **59**, the seventh lens may also have a second inflection point on the image-side surface of the seventh lens, and a thickness of the seventh lens at this inflection point is $Yc72P2$ as listed in Table 60.

FIG. **60** is a cross-sectional view illustrating an example of a shape of a rib of a lens.

The examples of the optical imaging system **100** described in this application may include a structure for preventing a flare phenomenon and reflection.

For example, the ribs of the first to seventh lenses **1000**, **2000**, **3000**, **4000**, **5000**, **6000**, and **7000** of the optical imaging system may be partially surface-treated to make the surface of the rib rough as illustrated in FIG. **60**. Methods of surface treatment may include chemical etching, physical

grinding, or any other surface treatment method capable of increasing a roughness of a surface.

A surface-treated area **EA** may be formed in an entire area from an edge of the optical portion of the lens through which light actually passes to an outer end of the rib. However, as illustrated in FIG. **60**, non-treated areas **NEA** including step portions **E11**, **E21**, and **E22** may not be surface-treated, or may be surface-treated to have a roughness less than a roughness of the surface-treated area **EA**. The step portions **E11**, **E21**, and **E22** are portions where the thickness of the rib abruptly changes. A width **G1** of a first non-treated area **NEA** formed on an object-side surface of the lens and including a first step portion **E11** may be different from a width **G2** of a second non-treated area **NEA** formed on an image-side surface of the lens and including a second step portion **E21** and a third step portion **E22**. In the example illustrated in FIG. **60**, **G1** is greater than **G2**.

The width **G1** of the first non-treated area **NEA** includes the first step portion **E11**, the second step portion **E21**, and the third step portion **E22** when viewed in an optical axis direction, and the width **G2** of the second non-treated area **NEA** includes the second step portion **E21** and the third step portion **E22** but not the first step portion **E11** when viewed in the optical axis direction. A distance **G4** from the outer end of the rib to the second step portion **E21** is smaller than a distance **G3** from the outer end of the rib to the first step portion **E11**. Also, a distance **G5** from the outer end of the rib to the third step portion **E22** is smaller than the distance **G3** from the outer end of the rib to the first step portion **E11**.

The positions at which the non-treated areas **NEA** and the step portions **E11**, **E21**, and **E22** are formed as described above may be advantageous for measuring a concentricity of the lens.

The examples described above enable the optical imaging system to be miniaturized and aberrations to be easily corrected.

While this disclosure includes specific examples, it will be apparent after an understanding of the disclosure of this application that various changes in form and details may be made in these examples without departing from the spirit and scope of the claims and their equivalents. The examples described herein are to be considered in a descriptive sense only, and not for purposes of limitation. Descriptions of features or aspects in each example are to be considered as being applicable to similar features or aspects in other examples. Suitable results may be achieved if the described techniques are performed in a different order, and/or if components in a described system, architecture, device, or circuit are combined in a different manner, and/or replaced or supplemented by other components or their equivalents. Therefore, the scope of the disclosure is defined not by the detailed description, but by the claims and their equivalents, and all variations within the scope of the claims and their equivalents are to be construed as being included in the disclosure.

What is claimed is:

1. An optical imaging system comprising:
 - a first lens comprising a positive refractive power, a convex object-side surface, and a concave image-side surface;
 - a second lens comprising a refractive power, a convex object-side surface, and a concave image-side surface;
 - a third lens comprising a refractive power, a convex object-side surface, and a concave image-side surface;
 - a fourth lens comprising a refractive power and a convex object-side surface;

75

- a fifth lens comprising a negative refractive power and a convex object-side surface;
- a sixth lens comprising a positive refractive power, a convex object-side surface, and a concave image-side surface; and
- a seventh lens comprising a negative refractive power, wherein the first lens, the second lens, the third lens, the fourth lens, the fifth lens, the sixth lens, and the seventh lens are disposed in order along an optical axis of the optical imaging system from an object side of the optical imaging system toward an image side of the optical imaging system.
2. The optical imaging system of claim 1, wherein the second lens comprises a negative refractive power.
3. The optical imaging system of claim 2, wherein the third lens comprises a positive refractive power.
4. The optical imaging system of claim 2, wherein the fourth lens comprises a positive refractive power.
5. The optical imaging system of claim 1, wherein the fourth lens comprises a positive refractive power.
6. The optical imaging system of claim 5, wherein the third lens comprises a negative refractive power.
7. The optical imaging system of claim 1, wherein the fourth lens comprises a concave image-side surface.
8. The optical imaging system of claim 1, wherein the fifth lens comprises a concave image-side surface, and wherein the seventh lens comprises a concave image-side surface.
9. The optical imaging system of claim 1, wherein the seventh lens comprises a concave object-side surface and a concave image-side surface.
10. The optical imaging system of claim 9, wherein the fourth lens comprises a convex image-side surface.
11. The optical imaging system of claim 1, wherein at least one inflection point is formed on either one or both of an object-side surface and an image-side surface of the sixth lens, and wherein at least one inflection point is formed on either one or both of an object-side surface and an image-side surface of the seventh lens.

76

12. The optical imaging system of claim 1, wherein a distance along the optical axis from an object-side surface of the first lens to the imaging plane is 6.0 mm or less.

13. The optical imaging system of claim 1, wherein an F No. of the optical imaging system is less than 1.7.

14. The optical imaging system of claim 1, wherein the optical imaging system satisfies $1 < |f_{134567} - f| / f$, where f_{134567} is a composite focal length of the first to seventh lenses calculated with an index of refraction of the second lens set to 1.0, f is an overall focal length of the optical imaging system, and f_{134567} and f are expressed in a same unit of measurement.

15. The optical imaging system of claim 1, further comprising a spacer disposed between the sixth and seventh lenses,

wherein the optical imaging system further satisfies $0.5 < S6d/f < 1.2$, where $S6d$ is an inner diameter of the spacer, f is the overall focal length of the optical imaging system, and $S6d$ and f are expressed in a same unit of measurement.

16. The optical imaging system of claim 1, wherein the optical imaging system further satisfies $0.4 < L1TR/L7TR < 0.7$, where $L1TR$ is an overall outer diameter of the first lens, $L7TR$ is an overall outer diameter of the seventh lens, and $L1TR$ and $L7TR$ are expressed in a same unit of measurement.

17. The optical imaging system of claim 1, wherein the optical imaging system further satisfies $0.5 < L_{1234TRavg} / L7TR < 0.75$, where $L_{1234TRavg}$ is an average value of overall outer diameters of the first to fourth lenses, $L7TR$ is an overall outer diameter of the seventh lens, and $L_{1234TRavg}$ and $L7TR$ are expressed in a same unit of measurement.

18. The optical imaging system of claim 1, wherein the optical imaging system further satisfies $0.5 < L_{12345TRavg} / L7TR < 0.76$, where $L_{12345TRavg}$ is an average value of overall outer diameters of the first to fifth lenses, $L7TR$ is an overall outer diameter of the seventh lens, and $L_{12345TRavg}$ and $L7TR$ are expressed in a same unit of measurement.

* * * * *