



US011781324B2

(12) **United States Patent**
Ylikangas et al.

(10) **Patent No.:** **US 11,781,324 B2**
(45) **Date of Patent:** ***Oct. 10, 2023**

(54) **UNLOCKING SYSTEM FOR PANELS**

(56) **References Cited**

(71) Applicant: **Välinge Innovation AB**, Viken (SE)

U.S. PATENT DOCUMENTS

(72) Inventors: **Roger Ylikangas**, Lerberget (SE); **Karl Quist**, Höganäs (SE); **Anders Nilsson**, Helsingborg (SE); **Caroline Landgård**, Höganäs (SE)

87,853 A 3/1869 Kappes
108,068 A 10/1870 Utley
(Continued)

(73) Assignee: **Välinge Innovation AB**, Viken (SE)

FOREIGN PATENT DOCUMENTS

(*) Notice: Subject to any disclaimer, the term of this patent is extended or adjusted under 35 U.S.C. 154(b) by 69 days.

CN 201588375 U 9/2010
CN 201110035241.6 1/2011
(Continued)

This patent is subject to a terminal disclaimer.

OTHER PUBLICATIONS

(21) Appl. No.: **17/342,624**

Swedish Office Action with Swedish Search Report in SE 1950024-8, including ITS-Search Report in ITS/SE19/00001, dated Sep. 3, 2019, Swedish Patent and Registration Office, 23 pages.

(22) Filed: **Jun. 9, 2021**

(Continued)

(65) **Prior Publication Data**

US 2021/0381255 A1 Dec. 9, 2021

Related U.S. Application Data

(63) Continuation of application No. 16/713,373, filed on Dec. 13, 2019, now Pat. No. 11,060,302.

Primary Examiner — Chi Q Nguyen

(74) *Attorney, Agent, or Firm* — Boone IP Law

(30) **Foreign Application Priority Data**

Jan. 10, 2019 (SE) 1950024-8

(57) **ABSTRACT**

(51) **Int. Cl.**

E04F 15/00 (2006.01)
E04F 15/02 (2006.01)

(Continued)

A set of essentially identical panels, such as building panels, provided with a mechanical locking system including a displaceable tongue arranged in a displacement groove having a first opening at a first edge of a first panel. The tongue is configured to be displaced in the displacement groove along a displacement axis to attain a locking state wherein a first portion of the tongue cooperates with a first tongue groove having a second opening at a second edge of an adjacent second panel, for vertical locking of the first and the second edge. A second portion of the tongue is configured to cooperate with the second edge of the adjacent second panel via an elongated element for vertical unlocking of the first and the second edge.

(52) **U.S. Cl.**

CPC *E04F 15/02038* (2013.01); *E04C 2/40* (2013.01); *E04F 15/04* (2013.01);
(Continued)

(58) **Field of Classification Search**

CPC *E04F 15/02033*; *E04F 15/02038*; *E04F 15/107*; *E04F 15/102*; *E04F 2201/042*;
(Continued)

17 Claims, 10 Drawing Sheets

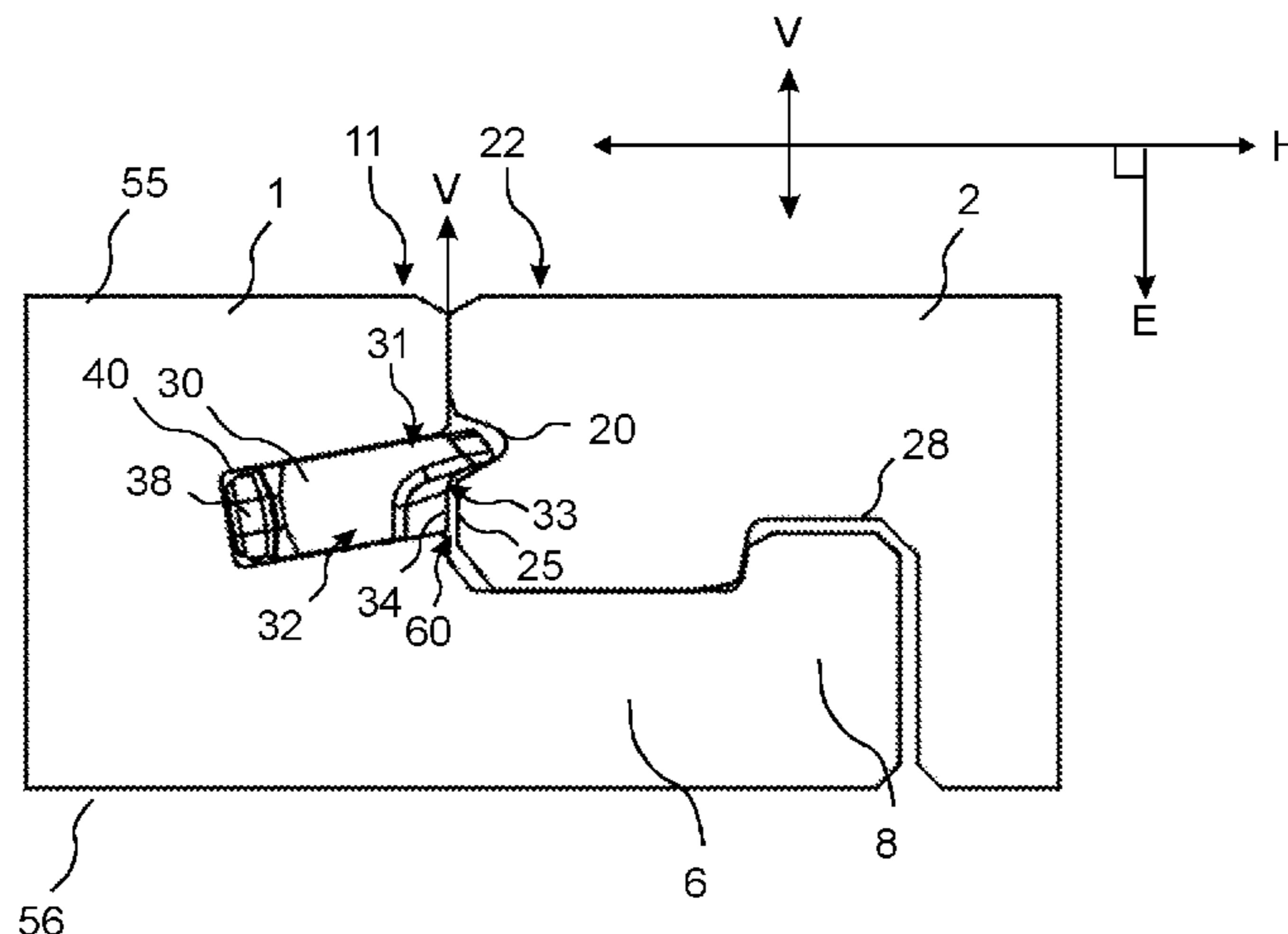

(51)	Int. Cl.		3,760,548 A	9/1973	Sauer et al.
	<i>E04F 15/04</i>	(2006.01)	3,764,767 A	10/1973	Randolph
	<i>E04C 2/40</i>	(2006.01)	3,778,954 A	12/1973	Meserole
(52)	U.S. Cl.		3,849,235 A	11/1974	Gwynne
	CPC ... <i>E04F 2201/023</i> (2013.01); <i>E04F 2201/044</i>		3,919,820 A	11/1975	Green
	(2013.01); <i>E04F 2201/0523</i> (2013.01)		3,950,915 A	4/1976	Cole
(58)	Field of Classification Search		3,994,609 A	11/1976	Puccio
	CPC <i>E04F 2201/0107</i> ; <i>E04F 2201/03</i> ; <i>E04F</i>		4,007,767 A	2/1977	Colledge
	<i>2201/0552</i> ; <i>E04F 2201/023</i> ; <i>E04F</i>		4,007,994 A	2/1977	Brown
	<i>2201/0535</i> ; <i>E04F 2201/0146</i> ; <i>E04F</i>		4,030,852 A	6/1977	Hein
	<i>2201/043</i> ; <i>E04F 2201/0547</i> ; <i>E04F</i>		4,037,377 A	7/1977	Howell et al.
	<i>2201/0153</i> ; <i>E04F 2201/0138</i> ; <i>E04F 15/04</i> ;		4,041,665 A	8/1977	de Munck
	<i>E04F 2201/044</i> ; <i>E05F 2201/0523</i> ; <i>E04C</i>		4,064,571 A	12/1977	Phipps
	<i>2/40</i>		4,080,086 A	3/1978	Watson
	USPC .. <i>52/592.1</i> , <i>592.3</i> , <i>592.2</i> , <i>578</i> , <i>588.1</i> , <i>309.1</i> ,		4,082,129 A	4/1978	Morelock
	<i>52/309.3</i>		4,100,710 A	7/1978	Kowallik
	See application file for complete search history.		4,104,840 A	8/1978	Heintz et al.
			4,107,892 A	8/1978	Bellem
			4,113,399 A	9/1978	Hansen, Sr. et al.
			4,154,041 A	5/1979	Namy
			4,169,688 A	10/1979	Toshio
			RE30,154 E	11/1979	Jarvis
(56)	References Cited		4,196,554 A	4/1980	Anderson
	U.S. PATENT DOCUMENTS		4,227,430 A	10/1980	Janssen et al.
			4,299,070 A	11/1981	Oltmanns
			4,304,083 A	12/1981	Anderson
			4,426,820 A *	1/1984	Terbrack <i>E04F 15/10</i> <i>52/590.1</i>
	124,228 A	3/1872 Stuart	4,447,172 A	5/1984	Galbreath
	213,740 A	4/1879 Conner	4,512,131 A	4/1985	Laramore
	274,354 A	3/1883 McCarthy et al.	4,599,841 A	7/1986	Haid
	316,176 A	4/1885 Ransom	4,622,784 A	11/1986	Black
	634,581 A	10/1899 Miller	4,648,165 A	3/1987	Whitehorne
	861,911 A	7/1907 Stewart	4,819,932 A	4/1989	Trotter, Jr.
	1,194,636 A	8/1916 Joy	4,948,716 A	8/1990	Mihayashi et al.
	1,723,306 A	8/1929 Sipe	4,998,395 A	3/1991	Bezner
	1,743,492 A	1/1930 Sipe	5,007,222 A	4/1991	Raymond
	1,809,393 A	6/1931 Rockwell	5,026,112 A	6/1991	Rice
	1,902,716 A	3/1933 Newton	5,071,282 A	12/1991	Brown
	2,026,511 A	12/1935 Storm	5,135,597 A	8/1992	Barker
	2,027,292 A	1/1936 Rockwell	5,148,850 A	9/1992	Urbanick
	2,110,728 A	3/1938 Hoggatt	5,173,012 A	12/1992	Ortwein et al.
	2,142,305 A	1/1939 Davis	5,182,892 A	2/1993	Chase
	2,204,675 A	6/1940 Grunert	5,247,773 A	9/1993	Weir
	2,266,464 A	12/1941 Kraft	5,272,850 A	12/1993	Mysliwiec et al.
	2,277,758 A	3/1942 Hawkins	5,274,979 A	1/1994	Tsai
	2,430,200 A	11/1947 Wilson	5,281,055 A	1/1994	Neitzke et al.
	2,596,280 A	5/1952 Nystrom	5,293,728 A	3/1994	Christopher et al.
	2,732,706 A	1/1956 Friedman	5,295,341 A	3/1994	Kajiwara
	2,740,167 A	4/1956 Rowley	5,344,700 A	9/1994	McGath et al.
	2,858,584 A	11/1958 Gaines	5,348,778 A	9/1994	Knipp et al.
	2,863,185 A	12/1958 Riedi	5,373,674 A	12/1994	Winter, IV
	2,865,058 A	12/1958 Andersson	5,465,546 A	11/1995	Buse
	2,889,016 A	6/1959 Warren	5,485,702 A	1/1996	Sholton
	3,023,681 A	3/1962 Worson	5,502,939 A	4/1996	Zadok et al.
	3,077,703 A	2/1963 Bergstrom	5,548,937 A	8/1996	Shimonohara
	3,099,110 A	7/1963 Spaight	5,577,357 A	11/1996	Civelli
	3,147,522 A	9/1964 Schumm	5,587,218 A	12/1996	Betz
	3,172,237 A	3/1965 Bradley	5,598,682 A	2/1997	Haughian
	3,187,612 A	6/1965 Hervey	5,616,389 A	4/1997	Blatz
	3,271,787 A	9/1966 Clary	5,618,602 A	4/1997	Nelson
	3,276,797 A	10/1966 Humes, Jr.	5,634,309 A	6/1997	Polen
	3,308,588 A	3/1967 Von Wedel	5,658,086 A	8/1997	Brokaw et al.
	3,325,585 A	6/1967 Brenneman	5,694,730 A	12/1997	Del Rincon et al.
	3,331,180 A	7/1967 Vissing et al.	5,755,068 A	5/1998	Ormiston
	3,378,958 A	4/1968 Parks et al.	5,860,267 A	1/1999	Pervan
	3,396,640 A	8/1968 Fujihara	5,899,038 A	5/1999	Stroppiana
	3,512,324 A	5/1970 Reed	5,910,084 A	6/1999	Koike
	3,517,927 A	6/1970 Kennel	5,950,389 A	9/1999	Porter
	3,526,071 A	9/1970 Watanabe	5,970,675 A	10/1999	Schray
	3,535,844 A	10/1970 Glaros	6,006,486 A	12/1999	Moriau
	3,572,224 A	3/1971 Perry	6,029,416 A	2/2000	Andersson
	3,579,941 A	5/1971 Tibbals	6,052,960 A	4/2000	Yonemura
	3,626,822 A	12/1971 Koster	6,065,262 A	5/2000	Motta
	3,640,191 A	2/1972 Hendrich	6,098,354 A	8/2000	Skandis
	3,694,983 A	10/1972 Couquet	6,122,879 A	9/2000	Montes
	3,720,027 A	3/1973 Christensen	6,134,854 A	10/2000	Stanchfield
	3,722,379 A	3/1973 Koester	6,145,261 A	11/2000	Godfrey et al.
	3,731,445 A	5/1973 Hoffmann et al.	6,164,618 A	12/2000	Yonemura
	3,742,669 A	7/1973 Mansfeld			
	3,760,547 A	9/1973 Brenneman			

(56)

References Cited

U.S. PATENT DOCUMENTS

			7,568,322 B2	8/2009	Pervan	
			7,584,583 B2	9/2009	Bergelin et al.	
			7,591,116 B2	9/2009	Thiers et al.	
			7,603,826 B1 *	10/2009	Moebus	E04F 15/04 52/592.4
6,173,548 B1	1/2001	Hamar et al.				
6,182,410 B1	2/2001	Pervan	7,614,197 B2	11/2009	Nelson	
6,203,653 B1	3/2001	Seidner	7,617,651 B2	11/2009	Grafenauer	
6,210,512 B1	4/2001	Jones	7,621,092 B2	11/2009	Groeke et al.	
6,254,301 B1	7/2001	Hatch	7,621,094 B2	11/2009	Moriau et al.	
6,295,779 B1	10/2001	Canfield	7,634,884 B2	12/2009	Pervan	
6,314,701 B1	11/2001	Meyerson	7,637,068 B2	12/2009	Pervan	
6,324,796 B1	12/2001	Heath	7,644,553 B2	1/2010	Knauseder	
6,324,809 B1	12/2001	Nelson	7,654,055 B2	2/2010	Ricker	
6,332,733 B1	12/2001	Hamberger	7,677,005 B2	3/2010	Pervan	
6,339,908 B1	1/2002	Chuang	7,716,889 B2	5/2010	Pervan	
6,345,481 B1	2/2002	Nelson	7,721,503 B2	5/2010	Pervan et al.	
6,358,352 B1	3/2002	Schmidt	7,726,088 B2	6/2010	Muehlebach	
6,363,677 B1	4/2002	Chen et al.	7,748,176 B2	7/2010	Harding et al.	
6,385,936 B1	5/2002	Schneider	7,757,452 B2	7/2010	Pervan	
6,418,683 B1	7/2002	Martensson et al.	7,802,411 B2	9/2010	Pervan	
6,446,413 B1	9/2002	Gruber	7,806,624 B2	10/2010	McLean et al.	
6,449,918 B1	9/2002	Nelson	7,827,749 B2	11/2010	Groeke et al.	
6,450,235 B1	9/2002	Lee	7,841,144 B2	11/2010	Pervan et al.	
6,490,836 B1	12/2002	Moriau et al.	7,841,145 B2	11/2010	Pervan et al.	
6,505,452 B1	1/2003	Hannig	7,841,150 B2	11/2010	Pervan	
6,546,691 B2	4/2003	Leopolder	7,849,642 B2	12/2010	Forster et al.	
6,553,724 B1	4/2003	Bigler	7,856,789 B2	12/2010	Eisermann	
6,576,079 B1	6/2003	Kai	7,861,482 B2	1/2011	Pervan et al.	
6,584,747 B2	7/2003	Kettler et al.	7,866,110 B2	1/2011	Pervan	
6,588,166 B2	7/2003	Martensson	7,896,571 B1	3/2011	Hannig et al.	
6,591,568 B1	7/2003	Pålsson	7,900,416 B1	3/2011	Yokubison et al.	
6,601,359 B2	8/2003	Olofsson	7,908,815 B2	3/2011	Pervan et al.	
6,617,009 B1	9/2003	Chen et al.	7,908,816 B2	3/2011	Grafenauer	
6,647,689 B2	11/2003	Pletzer et al.	7,913,471 B2	3/2011	Pervan	
6,647,690 B1	11/2003	Martensson	7,930,862 B2	4/2011	Bergelin et al.	
6,651,400 B1	11/2003	Murphy	7,954,295 B2	6/2011	Pervan	
6,670,019 B2	12/2003	Andersson	7,964,133 B2	6/2011	Cappelle	
6,672,030 B2	1/2004	Schulte	7,980,039 B2	7/2011	Groeke	
6,681,820 B2	1/2004	Olofsson	7,980,041 B2	7/2011	Pervan	
6,682,254 B1	1/2004	Olofsson et al.	8,001,741 B2	8/2011	Duernberger	
6,684,592 B2	2/2004	Martin	8,006,458 B1 *	8/2011	Olofsson	E04F 15/02016 52/489.1
6,685,391 B1	2/2004	Gideon				
6,729,091 B1	5/2004	Martensson	8,033,074 B2	10/2011	Pervan	
6,763,643 B1	7/2004	Martensson	8,042,311 B2	10/2011	Pervan	
6,766,622 B1	7/2004	Thiers	8,061,104 B2	11/2011	Pervan	
6,769,219 B2	8/2004	Schwitte et al.	8,079,196 B2	12/2011	Pervan	
6,769,835 B2	8/2004	Stridsman	8,112,967 B2	2/2012	Pervan et al.	
6,802,166 B1	10/2004	Gerhard	8,171,692 B2	5/2012	Pervan	
6,804,926 B1	10/2004	Eisermann	8,181,416 B2	5/2012	Pervan et al.	
6,808,777 B2	10/2004	Andersson et al.	8,191,334 B2	6/2012	Braun	
6,854,235 B2	2/2005	Martensson	8,220,217 B2	7/2012	Muehlebach	
6,862,857 B2	3/2005	Tychsen	8,234,830 B2	8/2012	Pervan et al.	
6,865,855 B2 *	3/2005	Knauseder	8,245,478 B2	8/2012	Bergelin	
		E04B 9/28 52/592.1	8,281,549 B2	10/2012	Du	
6,874,291 B1	4/2005	Weber	8,302,367 B2	11/2012	Schulte	
6,880,307 B2	4/2005	Schwitte et al.	8,336,272 B2	12/2012	Prager et al.	
6,948,716 B2	9/2005	Drouin	8,341,914 B2	1/2013	Pervan et al.	
7,021,019 B2	4/2006	Knauseder	8,341,915 B2	1/2013	Pervan et al.	
7,040,068 B2	5/2006	Moriau et al.	8,353,140 B2	1/2013	Pervan et al.	
7,051,486 B2	5/2006	Pervan	8,359,794 B2	1/2013	Biro et al.	
7,108,031 B1	9/2006	Secrest	8,359,805 B2	1/2013	Pervan et al.	
7,121,058 B2	10/2006	Pålsson	8,365,499 B2	2/2013	Nilsson et al.	
7,152,383 B1	12/2006	Wilkinson et al.	8,375,673 B2	2/2013	Evjen	
7,156,383 B1	1/2007	Jacobs	8,381,476 B2	2/2013	Hannig	
7,188,456 B2	3/2007	Knauseder	8,381,477 B2	2/2013	Pervan et al.	
7,219,392 B2	5/2007	Mullet et al.	8,387,327 B2	3/2013	Pervan	
7,251,916 B2	8/2007	Konzelmann et al.	8,448,402 B2	5/2013	Pervan et al.	
7,257,926 B1	8/2007	Kirby	8,499,521 B2	8/2013	Pervan et al.	
7,337,588 B1	3/2008	Moebus	8,505,257 B2	8/2013	Boo et al.	
7,377,081 B2	5/2008	Ruhdorfer	8,511,031 B2	8/2013	Bergelin et al.	
7,380,383 B2	6/2008	Olofsson et al.	8,522,505 B2	9/2013	Beach	
7,441,384 B2	10/2008	Miller et al.	8,528,289 B2	9/2013	Pervan et al.	
7,451,578 B2	11/2008	Hannig	8,544,230 B2	10/2013	Pervan	
7,454,875 B2	11/2008	Pervan et al.	8,544,232 B2	10/2013	Wybo	
7,516,588 B2	4/2009	Pervan	8,544,233 B2	10/2013	Pålsson	
7,517,427 B2	4/2009	Sjoberg et al.	8,544,234 B2	10/2013	Pervan et al.	
7,520,092 B2	4/2009	Showers et al.	8,572,922 B2	11/2013	Pervan	
7,533,500 B2	5/2009	Morton et al.	8,578,675 B2	11/2013	Palsson et al.	
7,556,849 B2	7/2009	Thompson et al.	8,590,250 B2	11/2013	Oh	

(56)

References Cited

U.S. PATENT DOCUMENTS

8,596,013 B2	12/2013	Boo	9,856,656 B2	1/2018	Pervan
8,615,952 B2	12/2013	Engström	9,874,027 B2	1/2018	Pervan
8,621,814 B2	1/2014	Cappelle	9,945,130 B2	4/2018	Nygren et al.
8,627,862 B2	1/2014	Pervan et al.	9,951,526 B2	4/2018	Boo et al.
8,631,623 B2	1/2014	Engström	10,000,935 B2	6/2018	Kell
8,635,829 B2	1/2014	Schulte	10,006,210 B2	6/2018	Pervan et al.
8,640,418 B2	2/2014	Paetrow et al.	10,017,948 B2	7/2018	Boo
8,640,424 B2	2/2014	Pervan et al.	10,113,319 B2	10/2018	Pervan
8,650,826 B2	2/2014	Pervan et al.	10,125,488 B2	11/2018	Boo
8,677,714 B2	3/2014	Pervan	10,138,636 B2	11/2018	Pervan
8,689,512 B2	4/2014	Pervan	10,161,139 B2	12/2018	Pervan
8,701,368 B2	4/2014	Vermeulen	10,180,005 B2	1/2019	Pervan et al.
8,707,650 B2	4/2014	Pervan	10,214,915 B2	2/2019	Pervan et al.
8,713,886 B2	5/2014	Boo et al.	10,214,917 B2	2/2019	Pervan et al.
8,733,065 B2	5/2014	Pervan	10,240,348 B2	3/2019	Pervan et al.
8,733,410 B2	5/2014	Pervan	10,240,349 B2	3/2019	Pervan et al.
8,763,341 B2	7/2014	Pervan	10,246,883 B2	4/2019	Derelöv
8,769,905 B2	7/2014	Pervan	10,352,049 B2	7/2019	Boo
8,776,473 B2	7/2014	Pervan et al.	10,358,830 B2	7/2019	Pervan
8,806,832 B2	8/2014	Kell	10,378,217 B2	8/2019	Pervan
8,833,026 B2	9/2014	Devos et al.	10,458,125 B2	10/2019	Pervan
8,844,236 B2	9/2014	Pervan et al.	10,480,196 B2	11/2019	Boo
8,857,126 B2	10/2014	Pervan et al.	10,519,676 B2	12/2019	Pervan
8,869,485 B2	10/2014	Pervan	10,526,792 B2	1/2020	Pervan et al.
8,887,468 B2	11/2014	Hakansson et al.	10,538,922 B2	1/2020	Pervan
8,898,988 B2	12/2014	Pervan	10,570,625 B2	2/2020	Pervan
8,925,274 B2	1/2015	Pervan et al.	10,640,989 B2	5/2020	Pervan
8,938,929 B2	1/2015	Engström	10,655,339 B2	5/2020	Pervan
8,959,866 B2	2/2015	Pervan	10,669,723 B2	6/2020	Pervan et al.
8,973,331 B2	3/2015	Boo	10,724,251 B2	7/2020	Kell
8,991,055 B2	3/2015	Cappelle	10,731,358 B2	8/2020	Pervan
8,997,423 B2	4/2015	Mann	10,794,065 B2	10/2020	Boo et al.
8,997,430 B1	4/2015	Vermeulen et al.	10,828,798 B2	11/2020	Fransson
9,027,306 B2	5/2015	Pervan	10,876,562 B2	12/2020	Pervan
9,051,738 B2	6/2015	Pervan et al.	10,933,592 B2	3/2021	Blomgren et al.
9,068,360 B2	6/2015	Pervan	10,934,721 B2	3/2021	Pervan et al.
9,080,329 B2	7/2015	Döhring	10,953,566 B2	3/2021	Fransson et al.
9,091,077 B2	7/2015	Boo	10,968,639 B2	4/2021	Pervan et al.
9,103,126 B2	8/2015	Kell	10,975,577 B2	4/2021	Pervan et al.
9,103,128 B2	8/2015	Pomberger	10,995,501 B2	5/2021	Pervan
9,151,062 B2	10/2015	Cappelle et al.	11,045,933 B2	6/2021	Fransson et al.
9,181,697 B2	11/2015	Masanek, Jr. et al.	11,053,691 B2	7/2021	Pervan
9,194,134 B2	11/2015	Nygren et al.	11,053,692 B2	7/2021	Pervan
9,206,611 B2 *	12/2015	Vermeulen E04B 5/023	11,060,302 B2 *	7/2021	Ylikangas E04F 15/02038
9,212,492 B2	12/2015	Pervan et al.	11,066,835 B2	7/2021	Boo
9,216,541 B2	12/2015	Boo et al.	11,078,673 B2	8/2021	Pervan et al.
9,238,917 B2	1/2016	Pervan et al.	11,091,920 B2	8/2021	Kell
9,284,737 B2	3/2016	Pervan et al.	11,131,099 B2	9/2021	Pervan
9,290,948 B2	3/2016	Capelle	11,174,646 B2	11/2021	Pervan
9,309,679 B2	4/2016	Pervan et al.	11,193,283 B2	12/2021	Pervan et al.
9,316,002 B2	4/2016	Boo	11,261,608 B2	3/2022	Pervan
9,340,974 B2	5/2016	Pervan et al.	11,274,453 B2	3/2022	Pervan
9,347,227 B2	5/2016	Ramachandra et al.	11,326,353 B2	5/2022	Nilsson et al.
9,347,469 B2	5/2016	Pervan	11,331,824 B2	5/2022	Myllykangas et al.
9,359,774 B2	6/2016	Pervan	2001/0024707 A1	9/2001	Andersson et al.
9,366,034 B2	6/2016	Meirlaen et al.	2001/0034991 A1	11/2001	Martensson
9,366,036 B2	6/2016	Pervan	2001/0045150 A1	11/2001	Owens
9,371,654 B2	6/2016	Capelle	2002/0014047 A1	2/2002	Thiers
9,376,821 B2	6/2016	Pervan et al.	2002/0031646 A1	3/2002	Chen et al.
9,382,716 B2	7/2016	Pervan et al.	2002/0069611 A1	6/2002	Leopolder
9,388,584 B2	7/2016	Pervan et al.	2002/0092263 A1	7/2002	Schulte
9,428,919 B2	8/2016	Pervan et al.	2002/0095894 A1	7/2002	Pervan
9,453,347 B2	9/2016	Pervan et al.	2002/0108343 A1	8/2002	Knauseder
9,458,634 B2	10/2016	Derelov	2002/0170258 A1	11/2002	Schwitte et al.
9,476,202 B2	10/2016	Clancy et al.	2002/0170259 A1	11/2002	Ferris
9,482,012 B2	11/2016	Nygren et al.	2002/0178674 A1	12/2002	Pervan
9,540,825 B2	1/2017	Ramachandra	2002/0178680 A1	12/2002	Martensson
9,540,826 B2	1/2017	Pervan et al.	2002/0189190 A1	12/2002	Charmat et al.
9,663,940 B2	5/2017	Boo	2002/0189747 A1	12/2002	Steinwender
9,725,912 B2	8/2017	Pervan	2002/0194807 A1	12/2002	Nelson et al.
9,771,723 B2	9/2017	Pervan	2003/0009971 A1	1/2003	Palmberg
9,777,487 B2	10/2017	Pervan et al.	2003/0024199 A1	2/2003	Pervan et al.
9,803,374 B2	10/2017	Pervan	2003/0037504 A1	2/2003	Schwitte et al.
9,803,375 B2	10/2017	Pervan	2003/0066588 A1	4/2003	Pålsson
9,822,533 B2	11/2017	Huang	2003/0084636 A1	5/2003	Pervan
			2003/0094230 A1	5/2003	Sjoberg
			2003/0101674 A1	6/2003	Pervan
			2003/0101681 A1	6/2003	Tychsen
			2003/0145549 A1	8/2003	Pålsson et al.

(56)

References Cited

U.S. PATENT DOCUMENTS

2003/0180091	A1	9/2003	Stridsman	2008/0110125	A1	5/2008	Pervan
2003/0188504	A1	10/2003	Ralf	2008/0134607	A1	6/2008	Pervan
2003/0196405	A1	10/2003	Pervan	2008/0134613	A1	6/2008	Pervan
2004/0016196	A1	1/2004	Pervan	2008/0134614	A1	6/2008	Pervan
2004/0031225	A1	2/2004	Fowler	2008/0155930	A1	7/2008	Pervan et al.
2004/0031227	A1	2/2004	Knauseder	2008/0184646	A1	8/2008	Alford
2004/0049999	A1	3/2004	Krieger	2008/0199676	A1	8/2008	Bathelier et al.
2004/0060255	A1	4/2004	Knauseder	2008/0216434	A1	9/2008	Pervan
2004/0068954	A1	4/2004	Martensson	2008/0216920	A1	9/2008	Pervan
2004/0123548	A1	7/2004	Gimpel et al.	2008/0236088	A1	10/2008	Hannig et al.
2004/0128934	A1	7/2004	Hecht	2008/0295432	A1	12/2008	Pervan et al.
2004/0137180	A1	7/2004	Sjoberg et al.	2008/0295438	A1	12/2008	Knauseder
2004/0139676	A1	7/2004	Knauseder	2008/0302044	A1	12/2008	Johansson
2004/0139678	A1	7/2004	Pervan	2009/0019806	A1	1/2009	Muehlebach
2004/0159066	A1	8/2004	Thiers et al.	2009/0049787	A1	2/2009	Hannig
2004/0168392	A1	9/2004	Konzelmann et al.	2009/0064624	A1	3/2009	Sokol
2004/0177584	A1	9/2004	Pervan	2009/0100782	A1	4/2009	Groeke et al.
2004/0182033	A1	9/2004	Wernersson	2009/0126308	A1	5/2009	Hannig et al.
2004/0182036	A1	9/2004	Sjoberg et al.	2009/0133353	A1	5/2009	Pervan et al.
2004/0200175	A1	10/2004	Weber	2009/0151290	A1	6/2009	Liu
2004/0211143	A1	10/2004	Hannig	2009/0173032	A1	7/2009	Prager et al.
2004/0238001	A1	12/2004	Risden	2009/0193741	A1	8/2009	Capelle
2004/0244325	A1	12/2004	Nelson	2009/0193748	A1	8/2009	Boo et al.
2004/0250492	A1	12/2004	Becker	2009/0193753	A1	8/2009	Schitter
2004/0261348	A1	12/2004	Vulin	2009/0217615	A1	9/2009	Engstrom
2005/0003132	A1	1/2005	Blix et al.	2009/0241460	A1	10/2009	Beaulieu
2005/0028474	A1	2/2005	Kim	2009/0249733	A1	10/2009	Moebus
2005/0050827	A1	3/2005	Schitter	2009/0308014	A1	12/2009	Muehlebach
2005/0160694	A1	7/2005	Pervan	2010/0018149	A1	1/2010	Thiers
2005/0166514	A1	8/2005	Pervan	2010/0043333	A1	2/2010	Hannig et al.
2005/0183370	A1	8/2005	Cripps	2010/0083603	A1	4/2010	Goodwin
2005/0021081	A1	9/2005	Pervan	2010/0170189	A1	7/2010	Schulte
2005/0205161	A1	9/2005	Lewark	2010/0173122	A1	7/2010	Susnjara
2005/0235593	A1	10/2005	Hecht	2010/0218450	A1	9/2010	Braun
2005/0252130	A1	11/2005	Martensson	2010/0275541	A1	11/2010	Prinz
2005/0252167	A1	11/2005	Van Horne, Jr.	2010/0281803	A1	11/2010	Cappelle
2005/0268570	A2	12/2005	Pervan	2010/0293879	A1	11/2010	Pervan et al.
2006/0053724	A1	3/2006	Braun et al.	2010/0031351	A1	12/2010	Tang
2006/0070333	A1	4/2006	Pervan	2010/0300029	A1	12/2010	Braun et al.
2006/0101769	A1	5/2006	Pervan	2010/0300031	A1	12/2010	Pervan et al.
2006/0156670	A1	7/2006	Knauseder	2010/0319290	A1	12/2010	Pervan
2006/0174577	A1	8/2006	O'Neil	2010/0319291	A1	12/2010	Pervan et al.
2006/0179754	A1	8/2006	Yang	2011/0016815	A1	1/2011	Yang
2006/0185287	A1	8/2006	Glazer et al.	2011/0030303	A1	2/2011	Pervan et al.
2006/0236642	A1	10/2006	Pervan	2011/0041996	A1	2/2011	Pervan
2006/0260254	A1	11/2006	Pervan et al.	2011/0047922	A1	3/2011	Fleming, III
2006/0272262	A1	12/2006	Pomberger	2011/0088344	A1	4/2011	Pervan et al.
2007/0003366	A1	1/2007	Wedberg	2011/0088345	A1	4/2011	Pervan
2007/0006543	A1	1/2007	Engström	2011/0088346	A1	4/2011	Hannig
2007/0011981	A1	1/2007	Eiserman	2011/0094178	A1	4/2011	Braun
2007/0022689	A1	2/2007	Thrush et al.	2011/0131916	A1	6/2011	Chen
2007/0028547	A1	2/2007	Grafenauer	2011/0138722	A1	6/2011	Hannig
2007/0065293	A1	3/2007	Hannig	2011/0154763	A1	6/2011	Bergelin et al.
2007/0094969	A1	5/2007	McIntosh et al.	2011/0162312	A1	7/2011	Schulte
2007/0094985	A1	5/2007	Grafenauer	2011/0167744	A1	7/2011	Whispell
2007/0108679	A1	5/2007	Grothaus	2011/0167750	A1	7/2011	Pervan
2007/0113509	A1	5/2007	Zhang	2011/0167751	A1	7/2011	Engström
2007/0151189	A1	7/2007	Yang et al.	2011/0173914	A1	7/2011	Engström
2007/0175156	A1	8/2007	Pervan et al.	2011/0197535	A1	8/2011	Baker et al.
2007/0193178	A1	8/2007	Groeke et al.	2011/0225921	A1	9/2011	Schulte
2007/0209736	A1	9/2007	Deringor et al.	2011/0225922	A1	9/2011	Pervan et al.
2007/0214741	A1	9/2007	Llorens Miravet	2011/0247285	A1	10/2011	Wybo et al.
2008/0000182	A1	1/2008	Pervan	2011/0252733	A1	10/2011	Pervan
2008/0000185	A1	1/2008	Duernberger	2011/0271631	A1	11/2011	Engstrom
2008/0000186	A1	1/2008	Pervan et al.	2011/0271632	A1	11/2011	Cappelle et al.
2008/0000187	A1	1/2008	Pervan et al.	2011/0283650	A1	11/2011	Pervan et al.
2008/0005998	A1	1/2008	Pervan	2012/0017533	A1	1/2012	Pervan et al.
2008/0010931	A1	1/2008	Pervan et al.	2012/0031029	A1	2/2012	Pervan et al.
2008/0010937	A1	1/2008	Pervan et al.	2012/0036804	A1	2/2012	Pervan
2008/0028707	A1	2/2008	Pervan	2012/0042598	A1	2/2012	Vermeulen et al.
2008/0034708	A1	2/2008	Pervan	2012/0055112	A1	3/2012	Engström
2008/0041008	A1	2/2008	Pervan	2012/0124932	A1	5/2012	Schulte et al.
2008/0053029	A1	3/2008	Ricker	2012/0151865	A1	6/2012	Pervan et al.
2008/0066415	A1	3/2008	Pervan	2012/0174515	A1	7/2012	Pervan
2008/0104921	A1	5/2008	Pervan et al.	2012/0174519	A1	7/2012	Schulte
				2012/0174520	A1	7/2012	Pervan
				2012/0174521	A1	7/2012	Schulte et al.
				2012/0192521	A1	8/2012	Schulte
				2012/0222378	A1	9/2012	Cappelle et al.

(56)

References Cited

U.S. PATENT DOCUMENTS

2012/0240502	A1	9/2012	Wilson et al.	2015/0211239	A1	7/2015	Pervan	
2012/0279161	A1	11/2012	Håkansson et al.	2015/0233125	A1	8/2015	Pervan et al.	
2012/0304590	A1	12/2012	Engström	2015/0267419	A1	9/2015	Pervan	
2012/0324816	A1	12/2012	Huang	2015/0300029	A1	10/2015	Pervan	
2013/0008117	A1	1/2013	Pervan	2015/0330088	A1*	11/2015	Derelov	E04F 15/02038
2013/0008118	A1	1/2013	Baert et al.					52/588.1
2013/0014463	A1	1/2013	Pervan	2015/0337537	A1	11/2015	Boo	
2013/0019555	A1	1/2013	Pervan	2015/0337542	A1	11/2015	Cappelle et al.	
2013/0025231	A1	1/2013	Vermeulen	2015/0368910	A1	12/2015	Kell	
2013/0025964	A1	1/2013	Ramachandra et al.	2016/0032596	A1	2/2016	Nygren et al.	
2013/0042562	A1	2/2013	Pervan	2016/0060879	A1	3/2016	Pervan	
2013/0042563	A1	2/2013	Pervan	2016/0069086	A1	3/2016	Hüllenkremer	
2013/0042564	A1*	2/2013	Pervan	2016/0069088	A1	3/2016	Boo et al.	
			E04F 15/02038	2016/0076260	A1	3/2016	Pervan et al.	
			52/582.2	2016/0090744	A1	3/2016	Pervan et al.	
2013/0042565	A1	2/2013	Pervan	2016/0153200	A1	6/2016	Pervan	
2013/0047536	A1	2/2013	Pervan	2016/0160502	A1	6/2016	Brousseau	
2013/0081349	A1	4/2013	Pervan et al.	2016/0168866	A1	6/2016	Pervan et al.	
2013/0111837	A1	5/2013	Devos et al.	2016/0186426	A1	6/2016	Boo	
2013/0111845	A1	5/2013	Pervan	2016/0194884	A1	7/2016	Pervan et al.	
2013/0145708	A1	6/2013	Pervan	2016/0201336	A1	7/2016	Pervan	
2013/0152500	A1	6/2013	Engström	2016/0237695	A1	8/2016	Pervan	
2013/0160391	A1	6/2013	Pervan et al.	2016/0251859	A1	9/2016	Pervan et al.	
2013/0167467	A1	7/2013	Vermeulen et al.	2016/0251860	A1	9/2016	Pervan	
2013/0219806	A1	8/2013	Carrubba	2016/0281368	A1	9/2016	Pervan et al.	
2013/0232905	A2	9/2013	Pervan	2016/0281370	A1	9/2016	Pervan et al.	
2013/0239508	A1	9/2013	Pervan et al.	2016/0289984	A1	10/2016	Wagner	
2013/0263454	A1	10/2013	Boo et al.	2016/0326751	A1	11/2016	Pervan	
2013/0263547	A1	10/2013	Boo	2016/0340913	A1	11/2016	Derelöv	
2013/0283719	A1	10/2013	Döhring et al.	2017/0030088	A1	2/2017	Simoens	
2013/0305650	A1	11/2013	Liu	2017/0037641	A1	2/2017	Nygren et al.	
2013/0309441	A1	11/2013	Hannig	2017/0067261	A1	3/2017	Hannig et al.	
2013/0318906	A1	12/2013	Pervan et al.	2017/0079433	A1	3/2017	Derelöv et al.	
2014/0007539	A1	1/2014	Pervan et al.	2017/0081860	A1	3/2017	Boo	
2014/0020324	A1	1/2014	Pervan	2017/0089379	A1	3/2017	Pervan	
2014/0026513	A1	1/2014	Bishop	2017/0254096	A1	9/2017	Pervan	
2014/0033633	A1	2/2014	Kell	2017/0321433	A1	11/2017	Pervan et al.	
2014/0033634	A1	2/2014	Pervan	2017/0328072	A1	11/2017	Hannig	
2014/0053497	A1	2/2014	Pervan et al.	2017/0362834	A1	12/2017	Pervan et al.	
2014/0059966	A1	3/2014	Boo	2018/0000151	A1	1/2018	Fransson	
2014/0069043	A1	3/2014	Pervan	2018/0001509	A1	1/2018	Myllykangas et al.	
2014/0090335	A1	4/2014	Pervan et al.	2018/0001573	A1	1/2018	Blomgren et al.	
2014/0109501	A1	4/2014	Pervan	2018/0002933	A1	1/2018	Pervan	
2014/0109506	A1	4/2014	Pervan et al.	2018/0016783	A1	1/2018	Boo	
2014/0123586	A1	5/2014	Pervan et al.	2018/0030737	A1	2/2018	Pervan	
2014/0130437	A1	5/2014	Cappelle	2018/0030738	A1	2/2018	Pervan	
2014/0140766	A1	5/2014	Riccobene et al.	2018/0119431	A1	5/2018	Pervan et al.	
2014/0144096	A1	5/2014	Vermeulen et al.	2018/0155934	A1	6/2018	D'Hondt et al.	
2014/0150369	A1	6/2014	Hannig	2018/0178406	A1	6/2018	Fransson et al.	
2014/0186104	A1	7/2014	Hamberger	2018/0313094	A1	11/2018	Pervan	
2014/0190112	A1	7/2014	Pervan	2018/0362138	A1	12/2018	Gross	
2014/0208677	A1	7/2014	Pervan et al.	2019/0024387	A1	1/2019	Pervan et al.	
2014/0223852	A1	8/2014	Pervan	2019/0048592	A1	2/2019	Boo	
2014/0237931	A1	8/2014	Pervan	2019/0048596	A1	2/2019	Pervan	
2014/0250813	A1	9/2014	Nygren et al.	2019/0063076	A1	2/2019	Boo et al.	
2014/0260060	A1	9/2014	Pervan et al.	2019/0071879	A1	3/2019	Thiers	
2014/0283466	A1	9/2014	Boo	2019/0093370	A1	3/2019	Pervan et al.	
2014/0290173	A1	10/2014	Hamberger	2019/0093371	A1	3/2019	Pervan	
2014/0305065	A1	10/2014	Pervan	2019/0119928	A1	4/2019	Pervan et al.	
2014/0338177	A1	11/2014	Vermeulen et al.	2019/0127989	A1	5/2019	Kell	
2014/0366476	A1	12/2014	Pervan	2019/0127990	A1	5/2019	Pervan et al.	
2014/0366477	A1	12/2014	Kell	2019/0169859	A1	6/2019	Pervan et al.	
2014/0373478	A2	12/2014	Pervan et al.	2019/0232473	A1	8/2019	Fransson et al.	
2014/0373480	A1	12/2014	Pervan et al.	2019/0271165	A1*	9/2019	Boo	E04C 2/40
2015/0000221	A1	1/2015	Boo	2019/0376298	A1	12/2019	Pervan et al.	
2015/0013260	A1	1/2015	Pervan	2019/0394314	A1	12/2019	Pervan et al.	
2015/0047278	A1	2/2015	Blount	2020/0087927	A1	3/2020	Pervan	
2015/0047284	A1	2/2015	Cappelle	2020/0102756	A1	4/2020	Pervan	
2015/0059281	A1	3/2015	Pervan	2020/0109569	A1	4/2020	Pervan	
2015/0089896	A2	4/2015	Pervan et al.	2020/0149289	A1	5/2020	Pervan	
2015/0113908	A1	4/2015	Ramachandra et al.	2020/0173175	A1	6/2020	Pervan	
2015/0121796	A1	5/2015	Pervan	2020/0181923	A1*	6/2020	Quist	E04F 15/02005
2015/0152644	A1	6/2015	Boo	2020/0224430	A1	7/2020	Ylikangas et al.	
2015/0167318	A1	6/2015	Pervan	2020/0263437	A1	8/2020	Pervan	
2015/0176289	A1	6/2015	Hannig	2020/0284045	A1	9/2020	Kell	
2015/0176619	A1	6/2015	Baker	2020/0318667	A1	10/2020	Derelöv	
				2020/0354969	A1	11/2020	Pervan et al.	
				2020/0412852	A9	12/2020	Pervan et al.	
				2021/0016465	A1	1/2021	Fransson	

(56)

References Cited

U.S. PATENT DOCUMENTS

2021/0047840 A1 2/2021 Pervan
 2021/0047841 A1 2/2021 Pervan et al.
 2021/0071428 A1 3/2021 Pervan
 2021/0087829 A1* 3/2021 Ylikangas E04F 13/0894
 2021/0087831 A1 3/2021 Nilsson et al.
 2021/0087832 A1 3/2021 Boo
 2021/0087833 A1 3/2021 Ylikangas et al.
 2021/0087834 A1 3/2021 Ylikangas et al.
 2021/0310257 A1* 10/2021 Boo E04F 15/02038
 2021/0348396 A1 11/2021 Pervan et al.
 2021/0381251 A1* 12/2021 Svensson F16B 5/0016
 2022/0025657 A1 1/2022 Pervan
 2022/0025658 A1 1/2022 Kell
 2022/0143718 A1 5/2022 Pervan et al.

FOREIGN PATENT DOCUMENTS

DE 138 992 C 7/1901
 DE 142 293 C 7/1902
 DE 2 159 042 6/1973
 DE 25 05 489 A1 8/1976
 DE 33 43 601 A1 6/1985
 DE 33 43 601 C2 6/1985
 DE 39 32 980 A1 11/1991
 DE 42 15 273 A1 11/1993
 DE 42 42 530 A1 6/1994
 DE 196 01 322 A 5/1997
 DE 299 22 649 U1 3/2000
 DE 200 02 744 U1 8/2000
 DE 199 40 837 A1 11/2000
 DE 199 58 225 A1 6/2001
 DE 202 05 774 U1 8/2002
 DE 10 2004 001 363 A1 8/2005
 DE 10 2005 002 297 A1 8/2005
 DE 10 2006 024 184 A1 11/2007
 DE 10 2007 018 309 A1 8/2008
 DE 10 2007 016 533 A1 10/2008
 DE 10 2007 032 885 A1 1/2009
 DE 10 2007 035 648 A1 1/2009
 DE 10 2007 049 792 A1 2/2009
 DE 10 2009 041 297 A1 3/2011
 EP 0 013 852 A1 8/1980
 EP 0 871 156 A2 10/1998
 EP 1 120 515 A1 8/2001
 EP 1 146 182 A2 10/2001
 EP 1 251 219 A 10/2002
 EP 1 279 778 A2 1/2003
 EP 1 350 904 A2 10/2003
 EP 1 396 593 A2 3/2004
 EP 1 420 125 A2 5/2004
 EP 1 437 457 A2 7/2004
 EP 1 640 530 A2 3/2006
 EP 1 650 375 A1 4/2006
 EP 1 980 683 A2 10/2008
 EP 2 000 610 A1 12/2008
 EP 2 236 694 A1 10/2010
 EP 2 270 291 A1 1/2011
 EP 2 278 091 A2 1/2011
 EP 2 333 195 A1 6/2011
 EP 2 388 394 A2 11/2011
 EP 2 333 195 B1 7/2014
 EP 2 734 684 B1 8/2016
 FR 1.138.595 6/1957
 FR 2 256 807 8/1975
 FR 2 810 060 A1 12/2001
 GB 240629 10/1925
 GB 376352 7/1932
 GB 1171337 11/1969
 GB 2 051 916 A 1/1981
 JP H03-110258 A 5/1991
 JP H05-018028 A 1/1993
 JP H06-146553 A 5/1994
 JP H06-288017 A 10/1994
 JP H06-306961 A 11/1994
 JP H06-322848 A 11/1994

JP H07-300979 A 11/1995
 JP 2900115 B2 6/1999
 JP 2002-047782 A 2/2002
 SE 526 688 C2 5/2005
 WO 94/26999 A1 11/1994
 WO 96/27721 A1 9/1996
 WO 97/47834 A1 12/1997
 WO 98/22677 A1 5/1998
 WO 99/66151 A1 12/1999
 WO 99/66152 A1 12/1999
 WO 00/43281 A2 7/2000
 WO 00/47841 A1 8/2000
 WO 00/55067 A1 9/2000
 WO 01/02670 A1 1/2001
 WO 01/02672 A1 1/2001
 WO 01/07729 A1 2/2001
 WO 01/38657 A1 5/2001
 WO 01/44669 A2 6/2001
 WO 01/48332 A1 7/2001
 WO 01/51732 A1 7/2001
 WO 01/51733 A1 7/2001
 WO 01/66877 A1 9/2001
 WO 01/75247 A1 10/2001
 WO 01/77461 A1 10/2001
 WO 02/055809 A1 7/2002
 WO 02/055810 A1 7/2002
 WO 02/081843 A1 10/2002
 WO 02/103135 A1 12/2002
 WO 03/012224 A1 2/2003
 WO 03/016654 A1 2/2003
 WO 03/025307 A1 3/2003
 WO 03/038210 A1 5/2003
 WO 03/044303 A1 5/2003
 WO 03/074814 A1 9/2003
 WO 03/083234 A1 10/2003
 WO 03/087497 A1 10/2003
 WO 03/089736 A1 10/2003
 WO 2004/003314 A1 1/2004
 WO 2004/020764 A1 3/2004
 WO 2004/048716 A1 6/2004
 WO 2004/050780 A2 6/2004
 WO 2004/079128 A1 9/2004
 WO 2004/079130 A1 9/2004
 WO 2004/085765 A1 10/2004
 WO 2005/003488 A1 1/2005
 WO 2005/003489 A1 1/2005
 WO 2005/054599 A1 6/2005
 WO 2006/050928 A1 5/2006
 WO 2006/104436 A1 10/2006
 WO 2006/123988 A1 11/2006
 WO 2006/125646 A1 11/2006
 WO 2007/015669 A2 2/2007
 WO 2007/142589 A1 12/2007
 WO 2008/004960 A2 1/2008
 WO 2008/017281 A1 2/2008
 WO 2008/060232 A1 5/2008
 WO 2009/066153 A2 5/2009
 WO 2009/116926 A1 9/2009
 WO 2010/070472 A2 6/2010
 WO 2010/070605 A2 6/2010
 WO 2010/087752 A1 8/2010
 WO 2011/001326 A2 1/2011
 WO 2011/012104 A2 2/2011
 WO 2011/012105 A1 2/2011
 WO 2011/032540 A2 3/2011
 WO 2011/038709 A1 4/2011
 WO 2011/108812 A2 9/2011
 WO 2011/151758 A2 12/2011
 WO 2012/059093 A2 5/2012
 WO 2013/012386 A1 1/2013
 WO 2014/209213 A1 12/2014
 WO 2015/105449 A1 7/2015

OTHER PUBLICATIONS

International Search Report and Written Opinion issued in PCT/SE2019/051280, dated Jan. 30, 2020, ISA/SE, Patent-och registreringsverket, Stockholm, SE, 14 pages.

(56)

References Cited

OTHER PUBLICATIONS

Välinge Innovation AB, Technical Disclosure entitled "Mechanical locking for floor panels with a flexible bristle tongue," IP.com No. IPCOM000145262D, Jan. 12, 2007, IP.com Prior Art Database, 57 pages (VA033).

Engstrand, Ola (Contact)/Välinge Innovation AB, Technical Disclosure entitled "VA-038 Mechanical Locking of Floor Panels With Vertical Folding," IP.com No. IPCOM000179246D, Feb. 10, 2009, IP.com Prior Art Database, 59 pages.

Engstrand, Ola (Contact)/Välinge Innovation AB, Technical Disclosure entitled "VA043 5G Linear Slide Tongue," IP.com No. IPCOM000179015D, Feb. 4, 2009, IP.com Prior Art Database, 126 pages.

Engstrand, Ola (Owner)/Välinge Innovation AB, Technical Disclosure entitled "VA043b PCT Mechanical Locking of Floor Panels," IP.com No. IPCOM000189420D, Nov. 9, 2009, IP.com Prior Art Database, 62 pages.

Engstrand, Ola (Contact)/Välinge Innovation AB, Technical Disclosure entitled "VA055 Mechanical locking system for floor panels," IP.com No. IPCOM000206454D, Apr. 27, 2011, IP.com Prior Art Database, 25 pages.

Engstrand, Ola (Contact)/Välinge Innovation AB, Technical Disclosure entitled "VA058 Rocker Tongue," IP.com No. IPCOM000203832D, Feb. 4, 2011, IP.com Prior Art Database, 22 pages.

Pervan, Darko (Author)/Välinge Flooring Technology, Technical Disclosure entitled "VA066b Glued Tongue," IP.com No. IPCOM000210865D, Sep. 13, 2011, IP.com Prior Art Database, 19 pages.

Pervan, Darko (Inventor)/Välinge Flooring Technology AB, Technical Disclosure entitled "VA067 Fold Slide Loc," IP.com No. IPCOM000208542D, Jul. 12, 2011, IP.com Prior Art Database, 37 pages.

Pervan, Darko (Author)/Välinge Flooring Technology, Technical Disclosure entitled "VA068 Press Lock VFT," IP.com No. IPCOM000208854D, Jul. 20, 2011, IP.com Prior Art Database, 25 pages.

Pervan, Darko (Author), Technical Disclosure entitled "VA069 Combi Tongue," IP.com No. IPCOM000210866D, Sep. 13, 2011, IP.com Prior Art Database, 41 pages.

Pervan, Darko (Author), Technical Disclosure entitled "VA070 Strip Part," IP.com No. IPCOM000210867D, Sep. 13, 2011, IP.com Prior Art Database, 43 pages.

Pervan, Darko (Author), Technical Disclosure entitled "VA071 Pull Lock," IP.com No. IPCOM000210868D, Sep. 13, 2011, IP.com Prior Art Database, 22 pages.

Pervan, Darko (Author), Technical Disclosure entitled "VA073a Zip Loc," IP.com No. IPCOM000210869D, Sep. 13, 2011, IP.com Prior Art Database, 36 pages.

LifeTips, "Laminate Flooring Tips," available at (<http://flooring.lifetips.com/cat/61734/laminate-flooring-tips/index.html>), 2000, 12 pages.

Pervan, Darko, et al., U.S. Appl. No. 17/518,836 entitled "Mechanical Locking of Floor Panels with a Flexible Bristle Tongue," filed Nov. 4, 2021.

Boo, Fredrik, et al., U.S. Appl. No. 17/697,334, entitled "Building Panel with a Mechanical Locking System," filed Mar. 17, 2022.

* cited by examiner

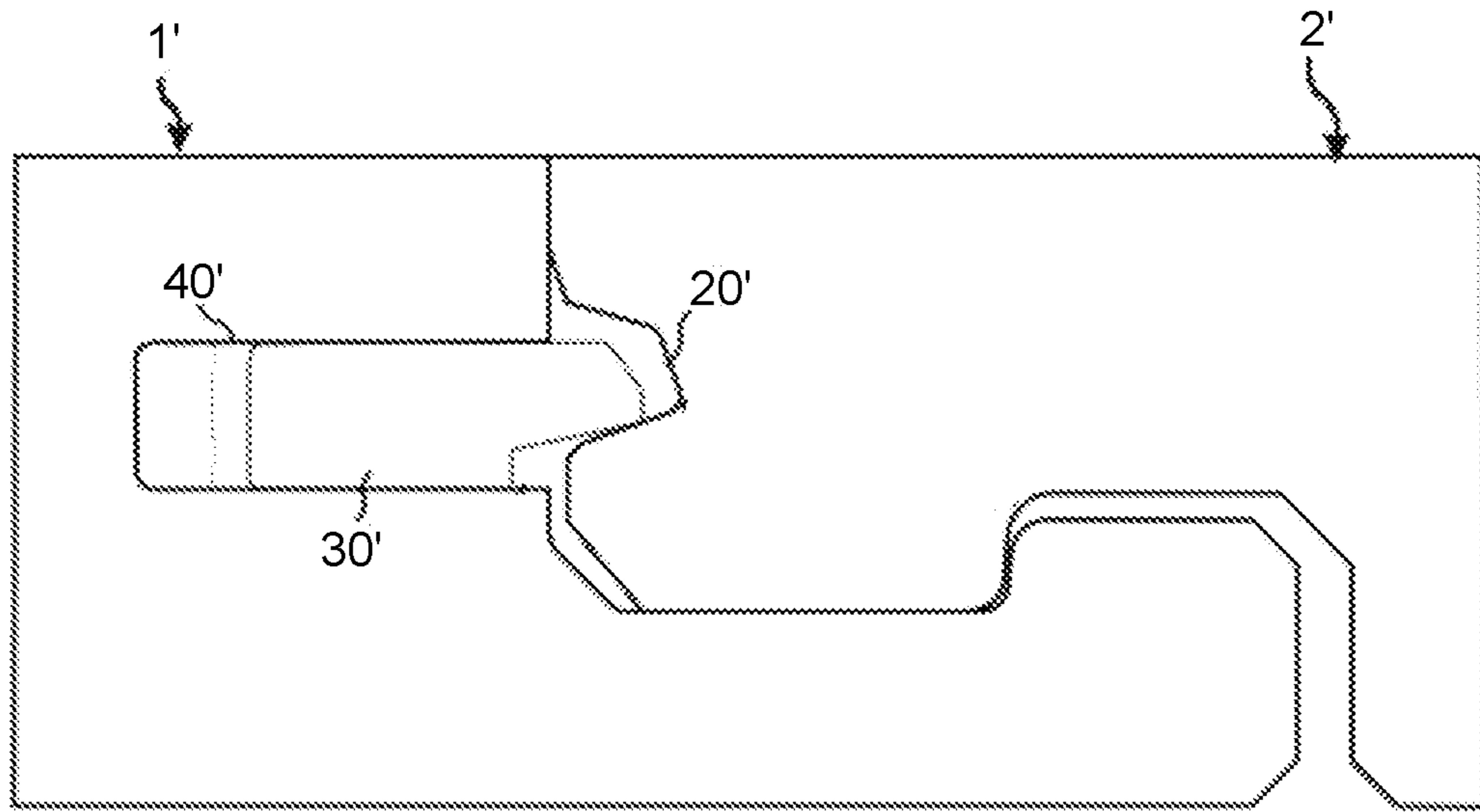

Prior art

FIG. 1A

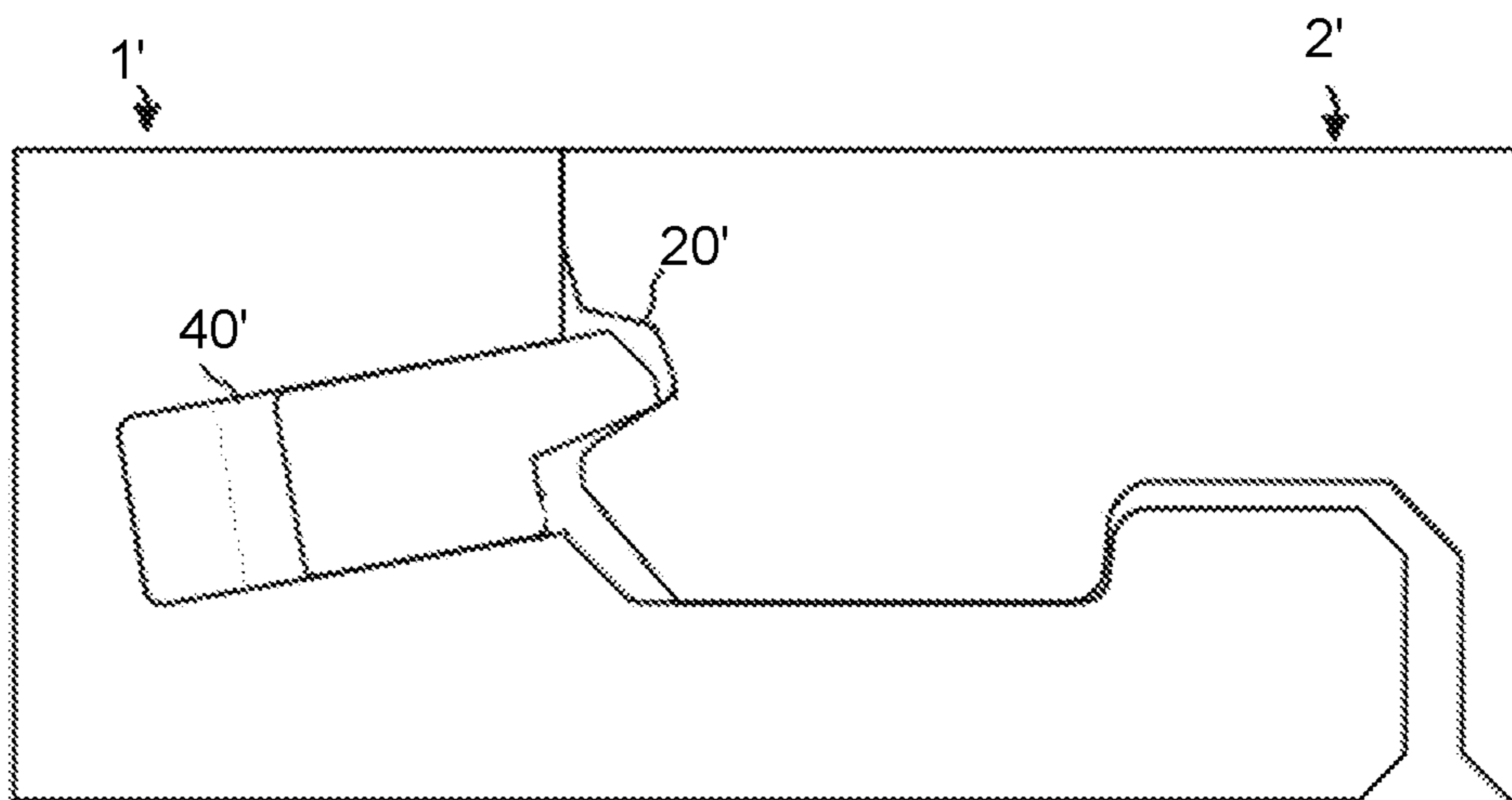

Prior art

FIG. 1B

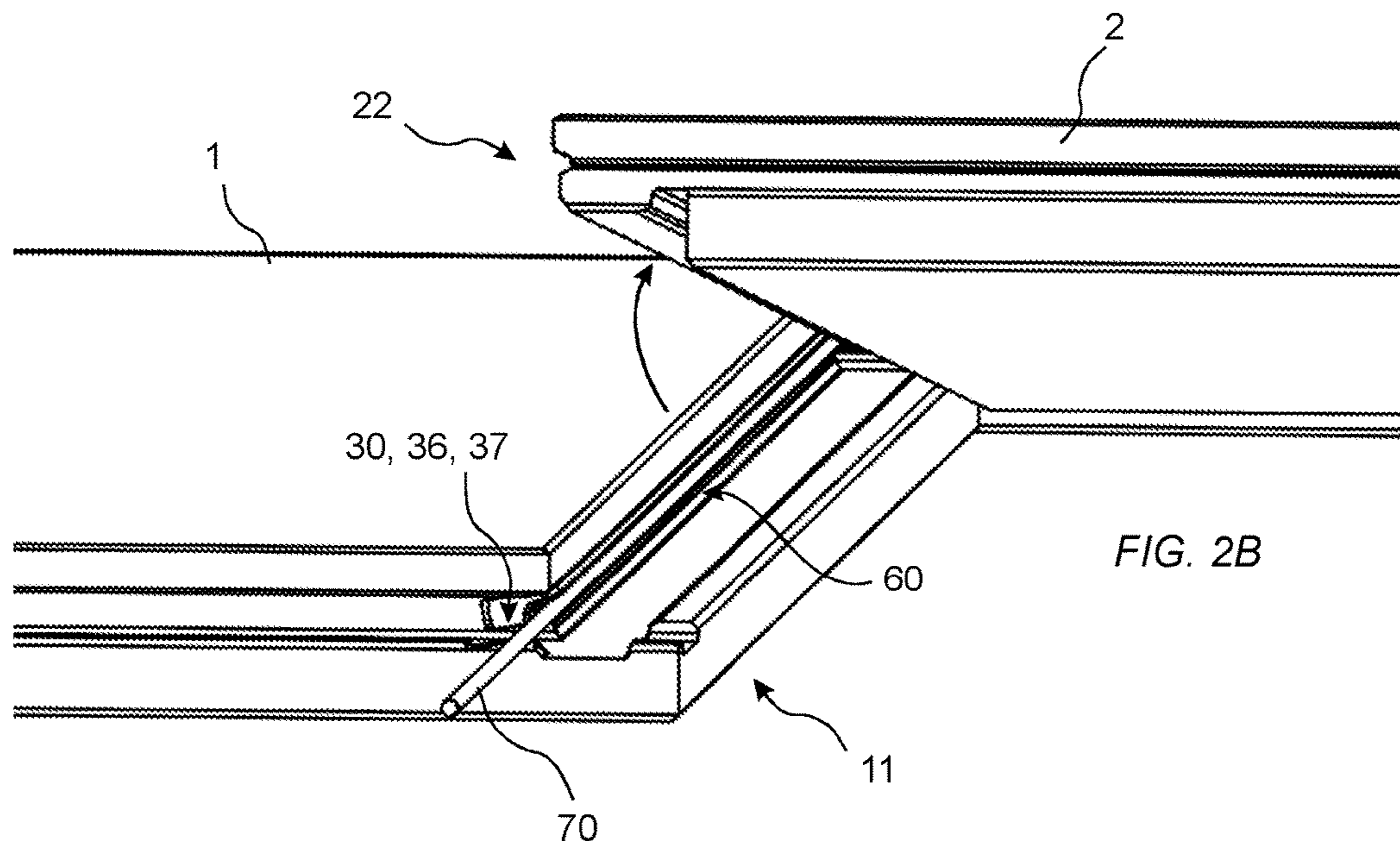
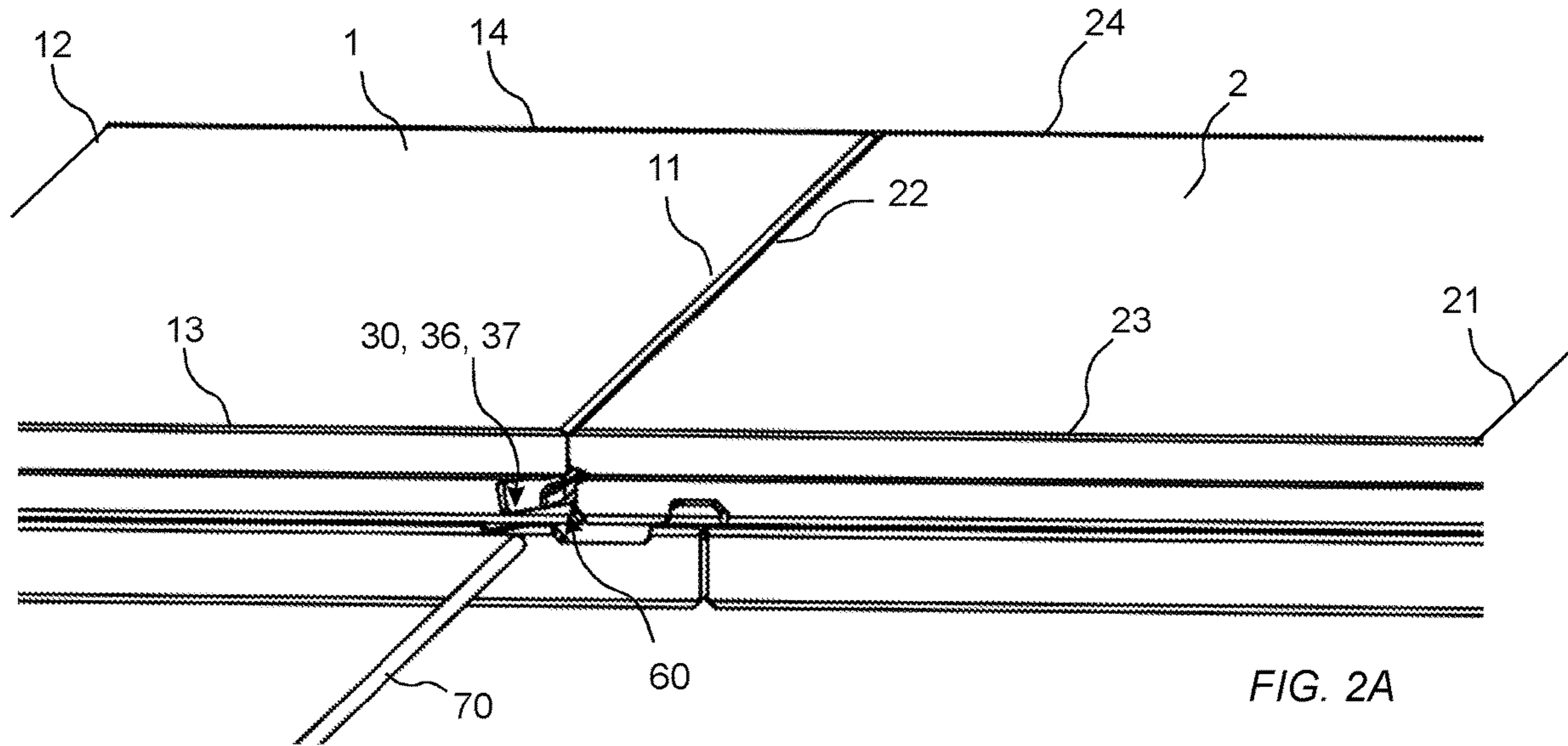

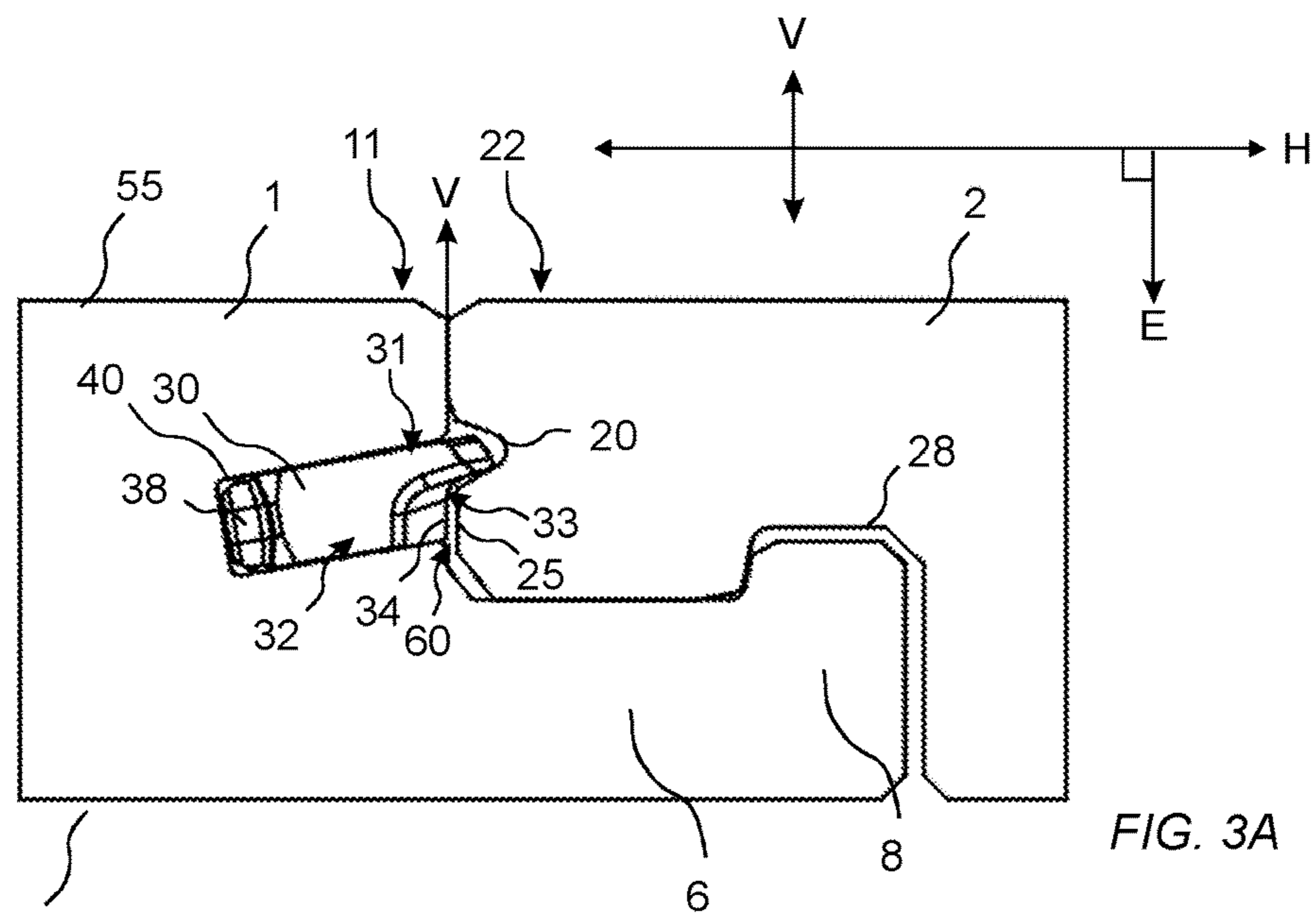

FIG. 3A

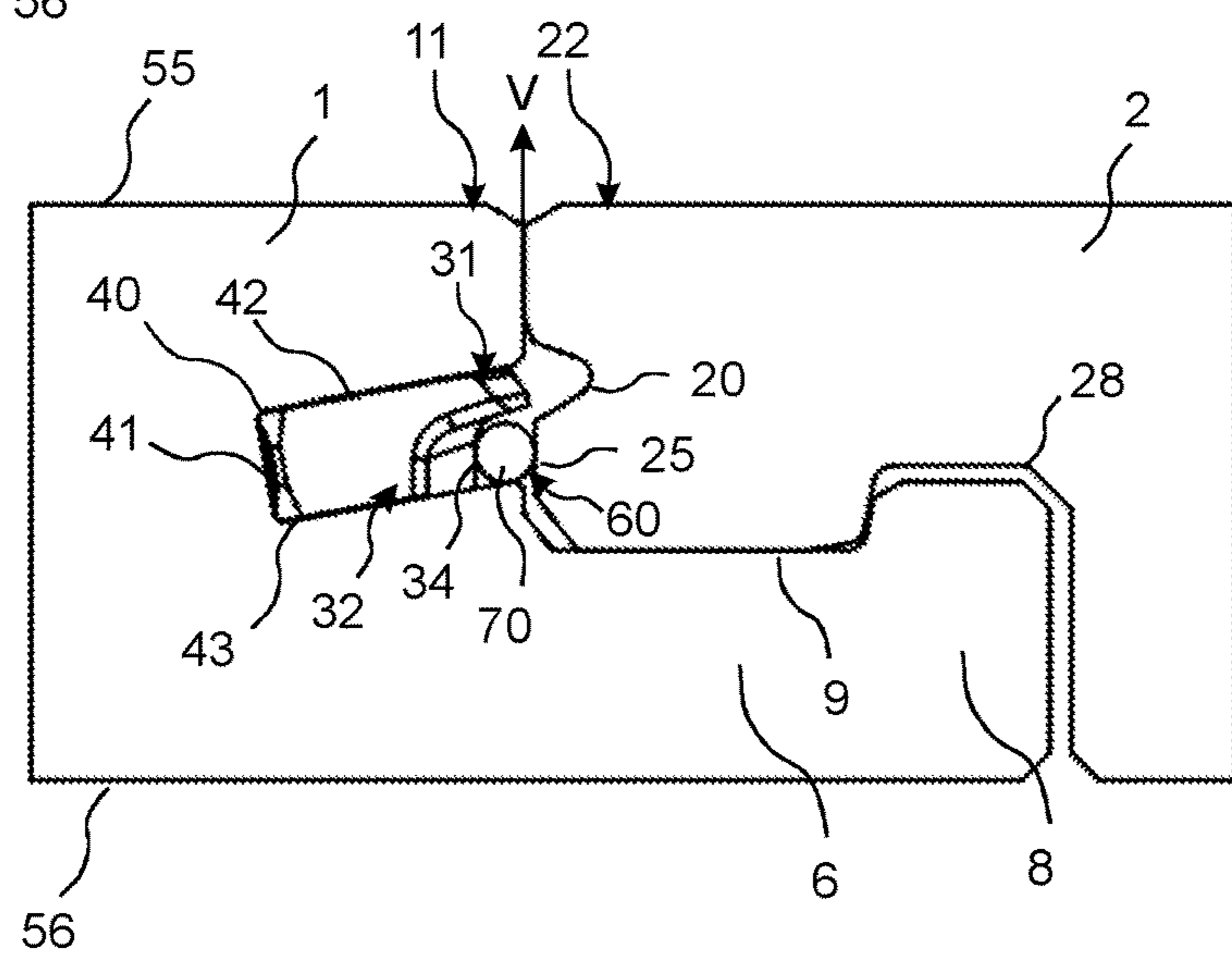

FIG. 3B

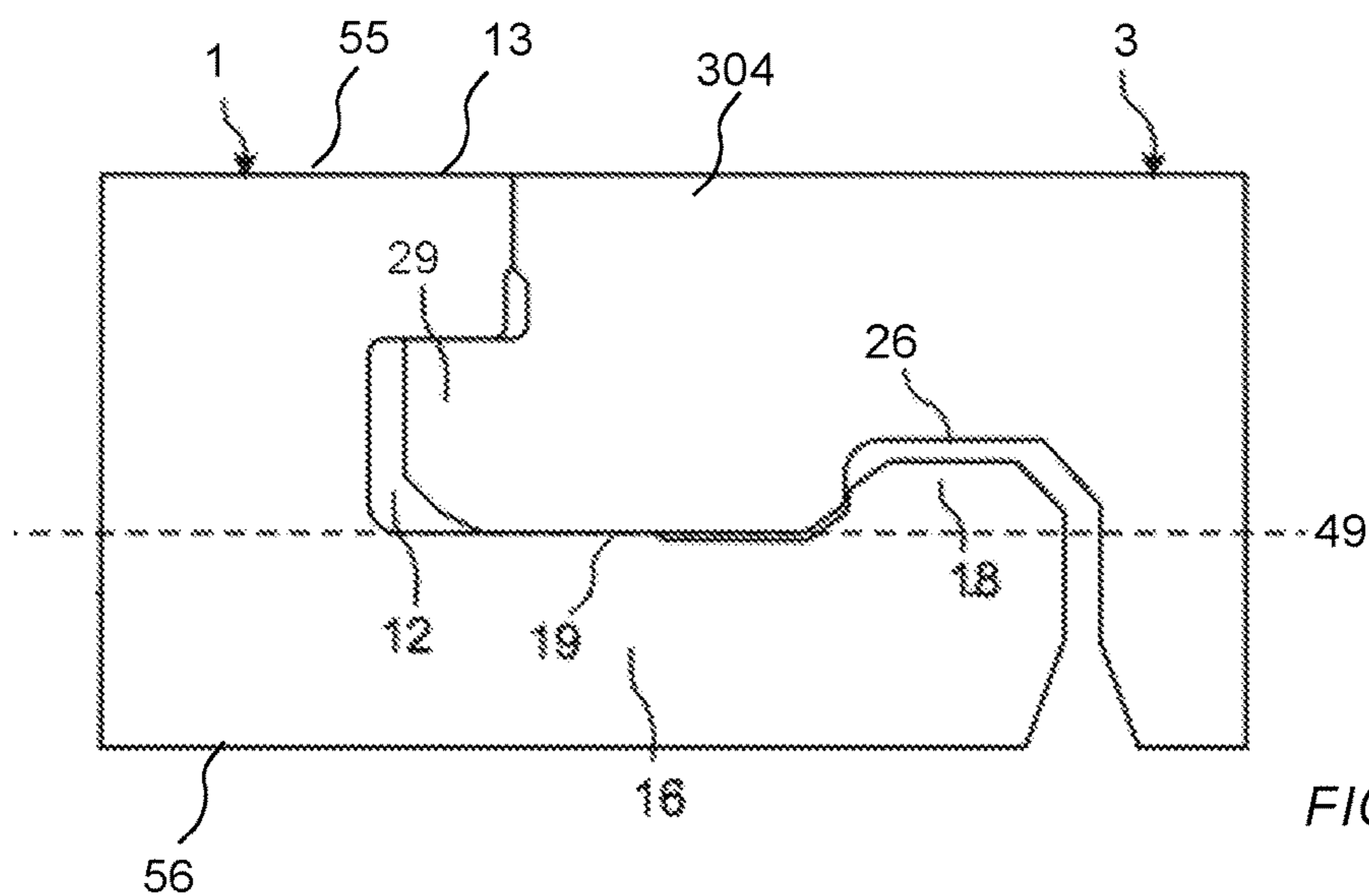

FIG. 3C

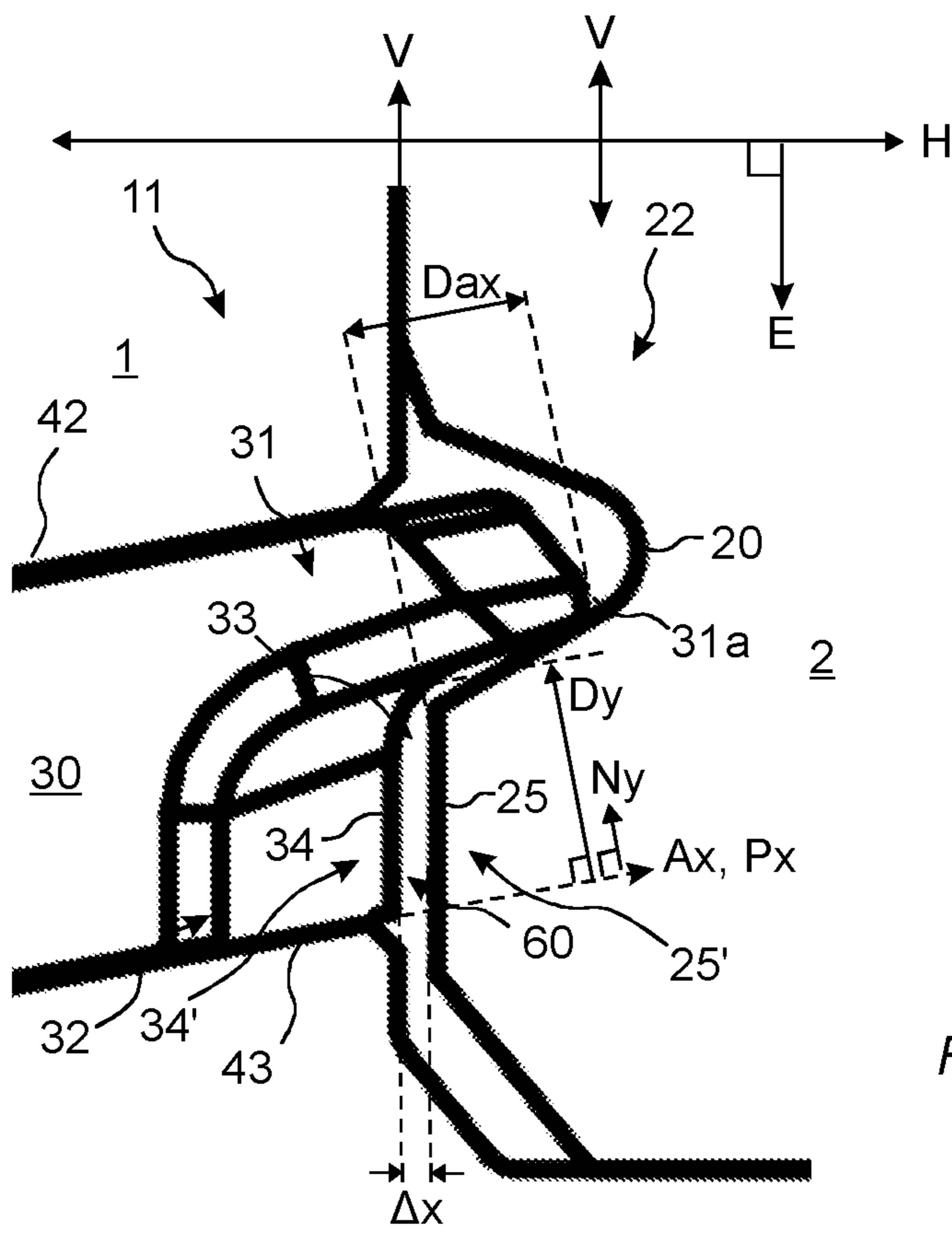
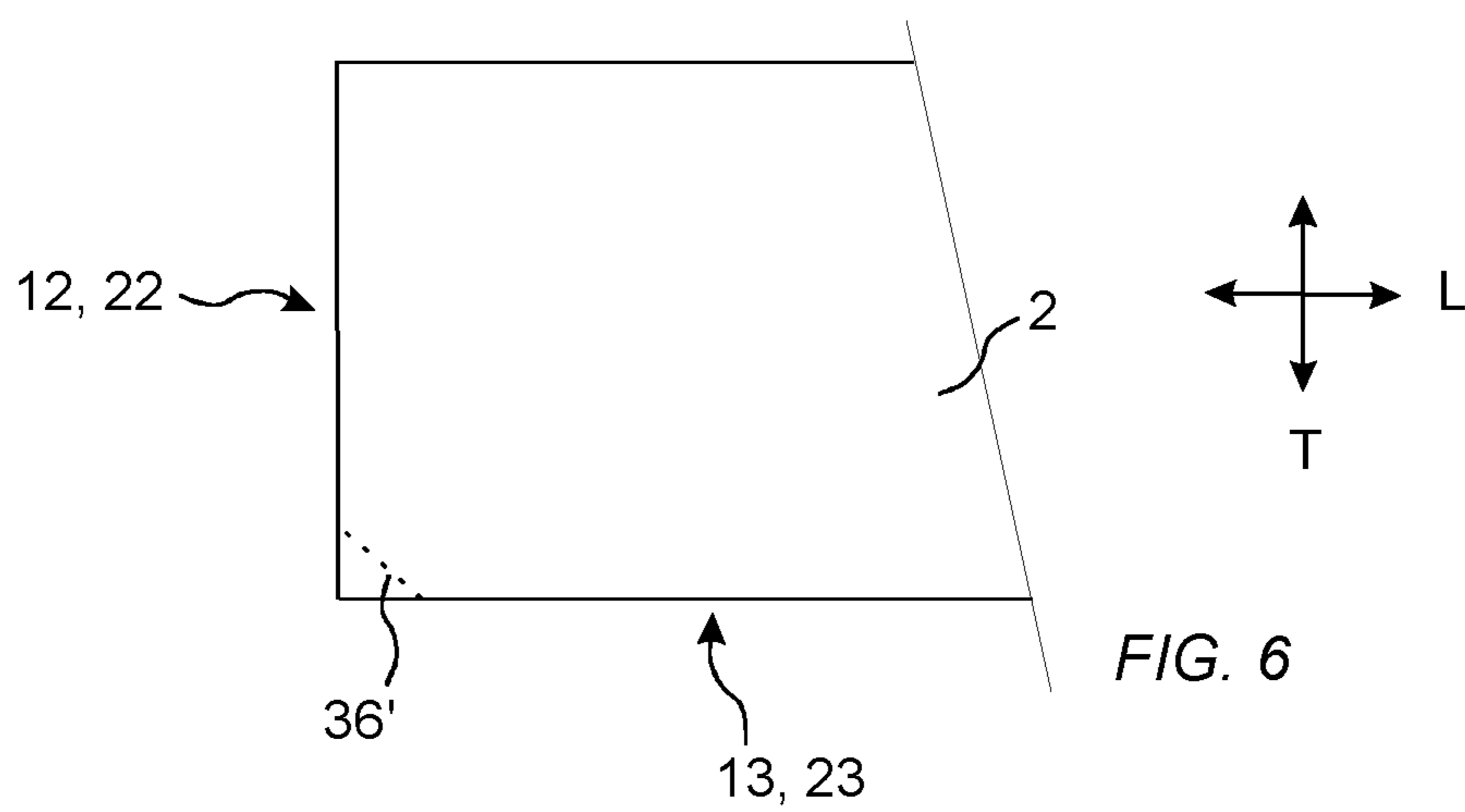
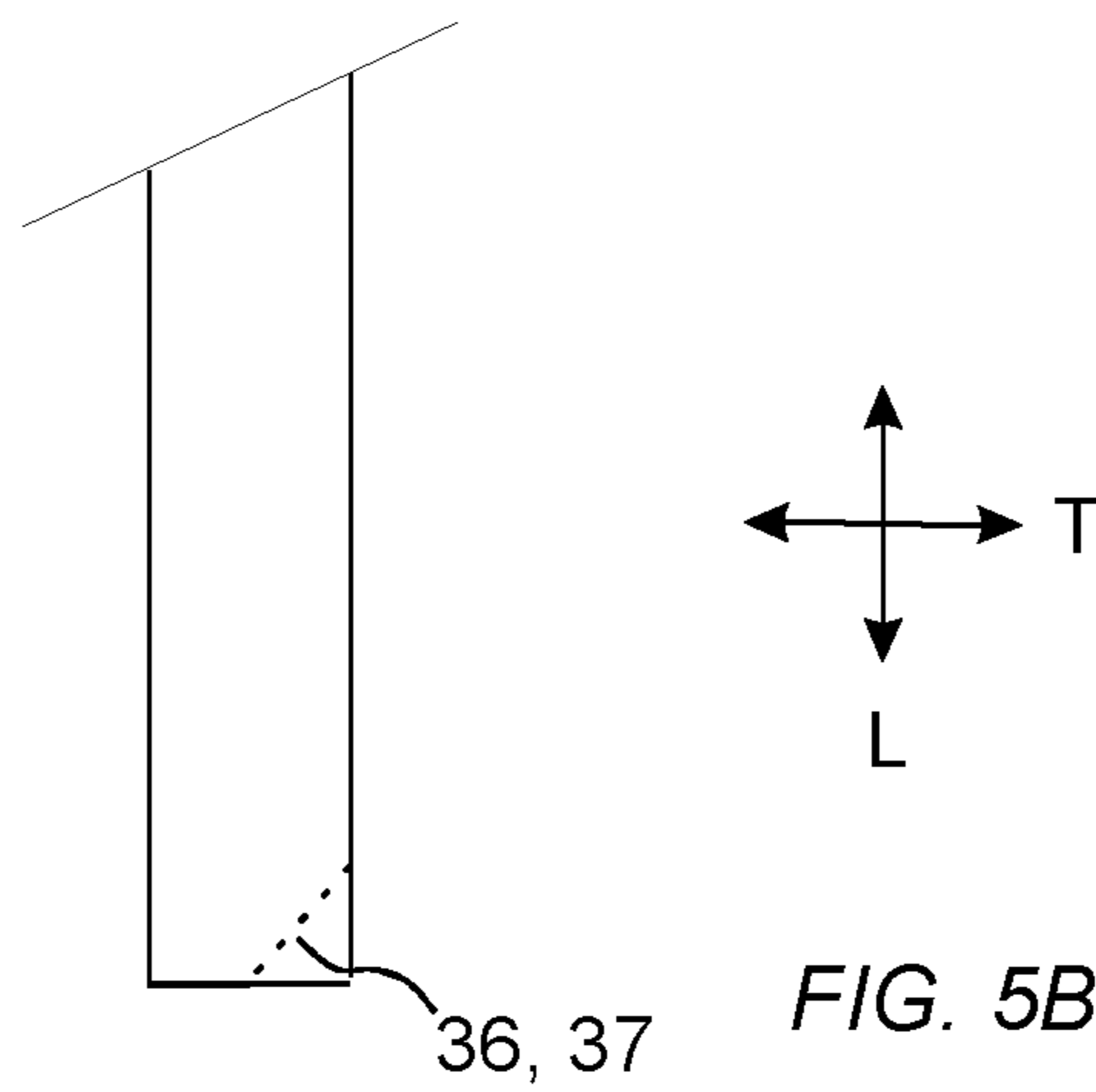
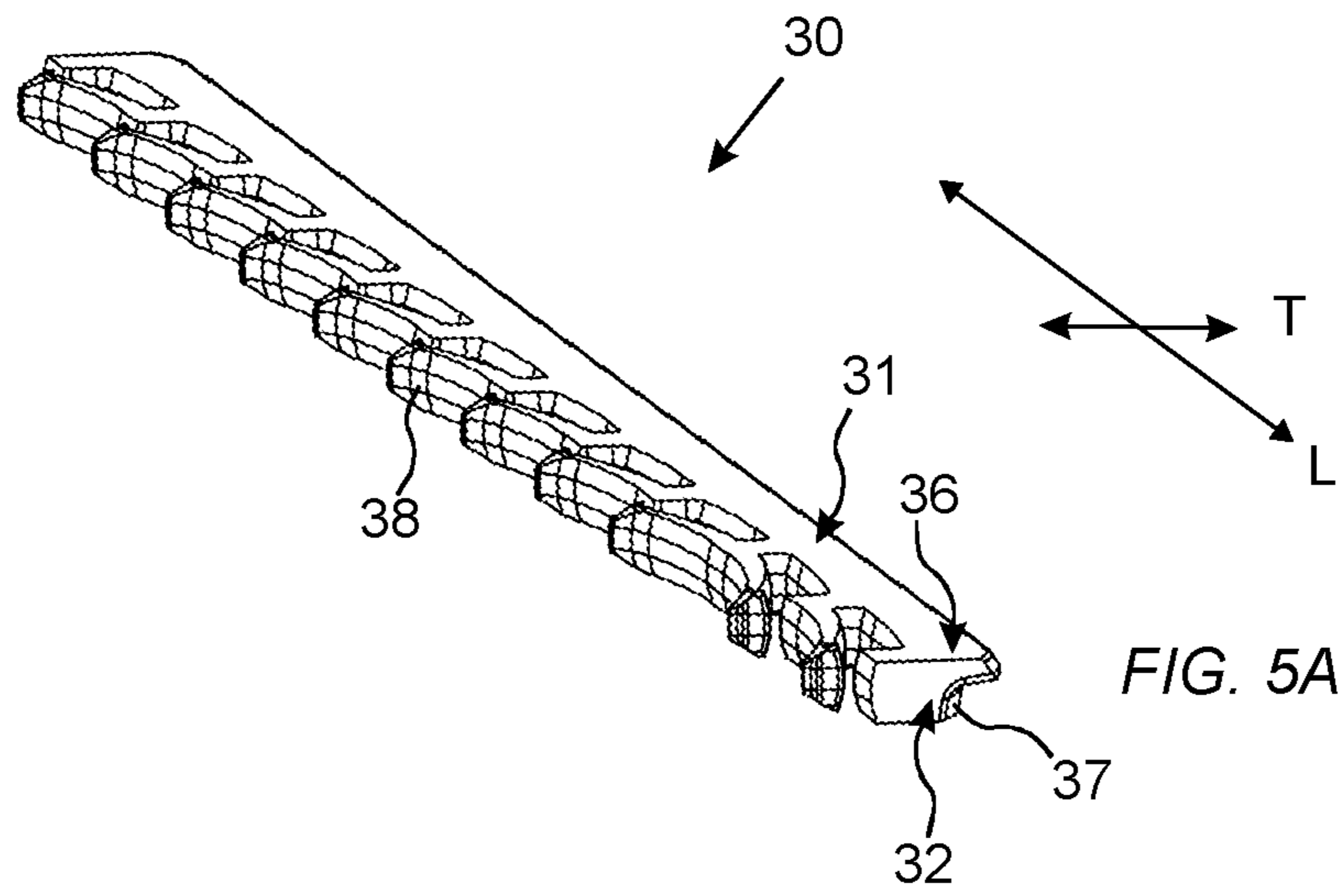

FIG. 4C



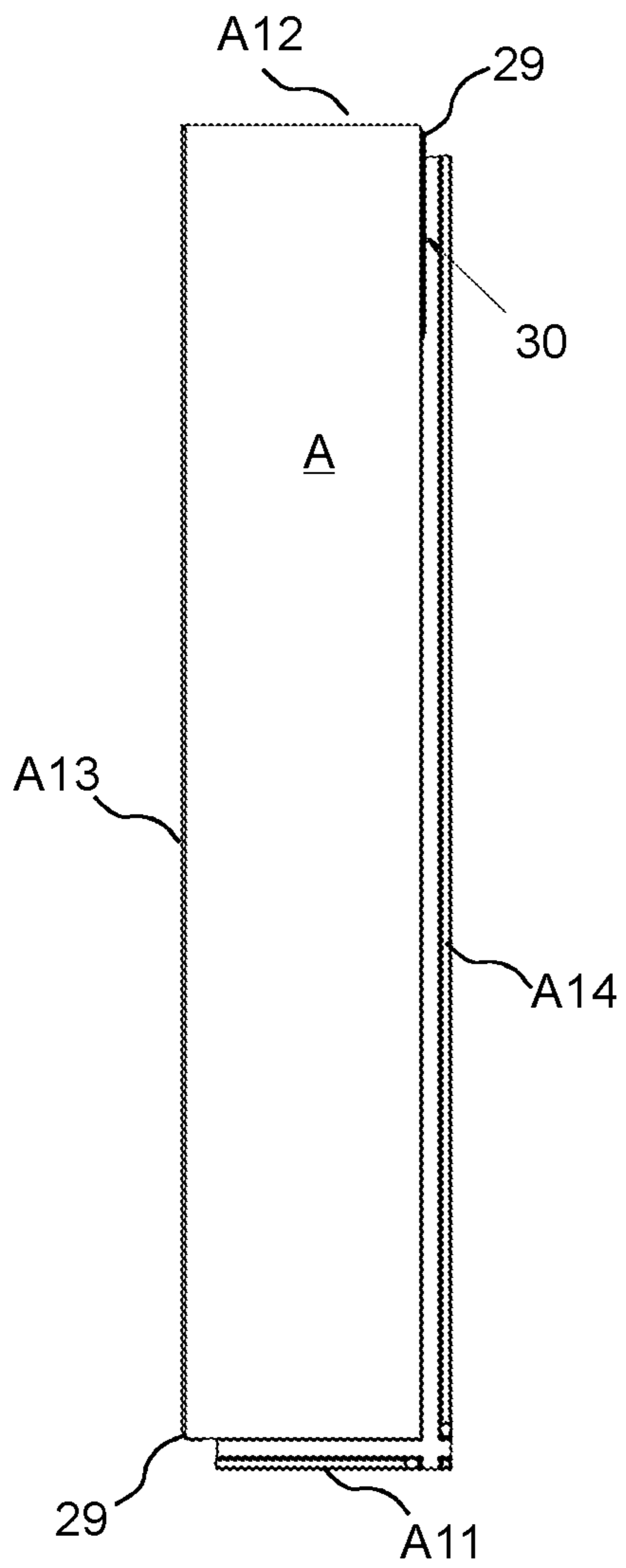

FIG. 7A

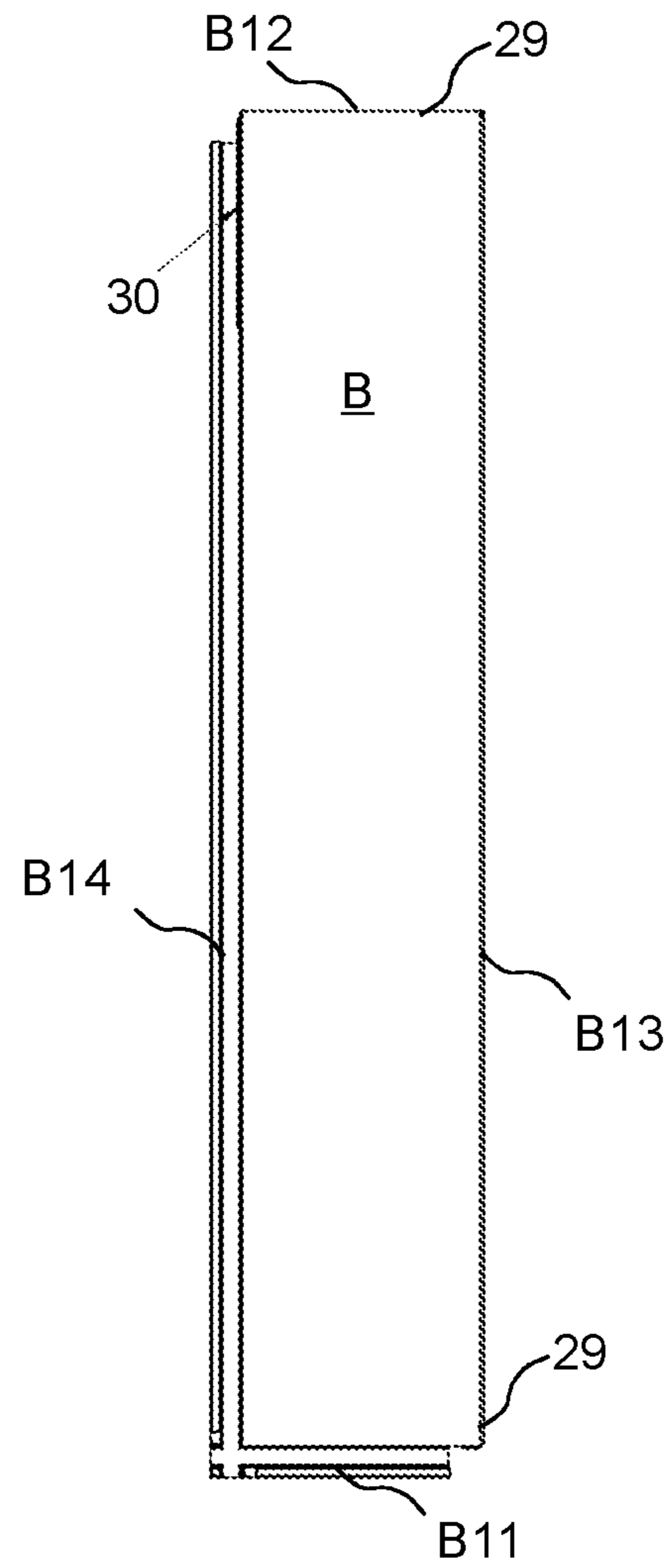

FIG. 7B

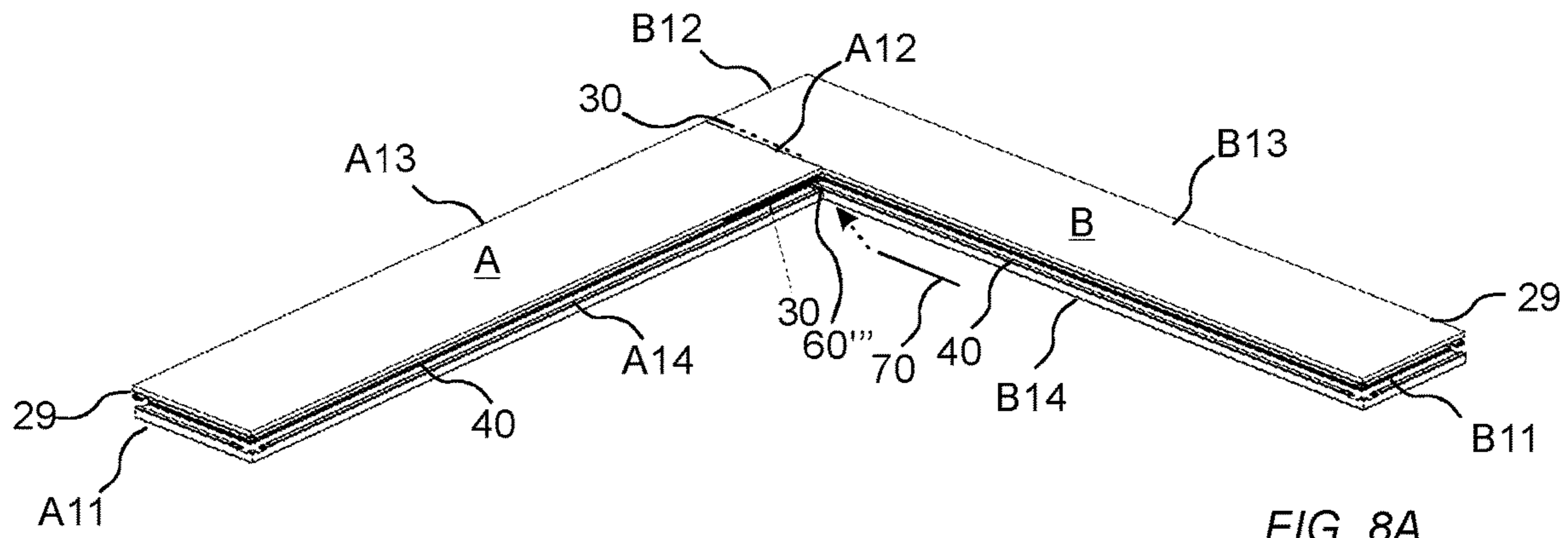

FIG. 8A

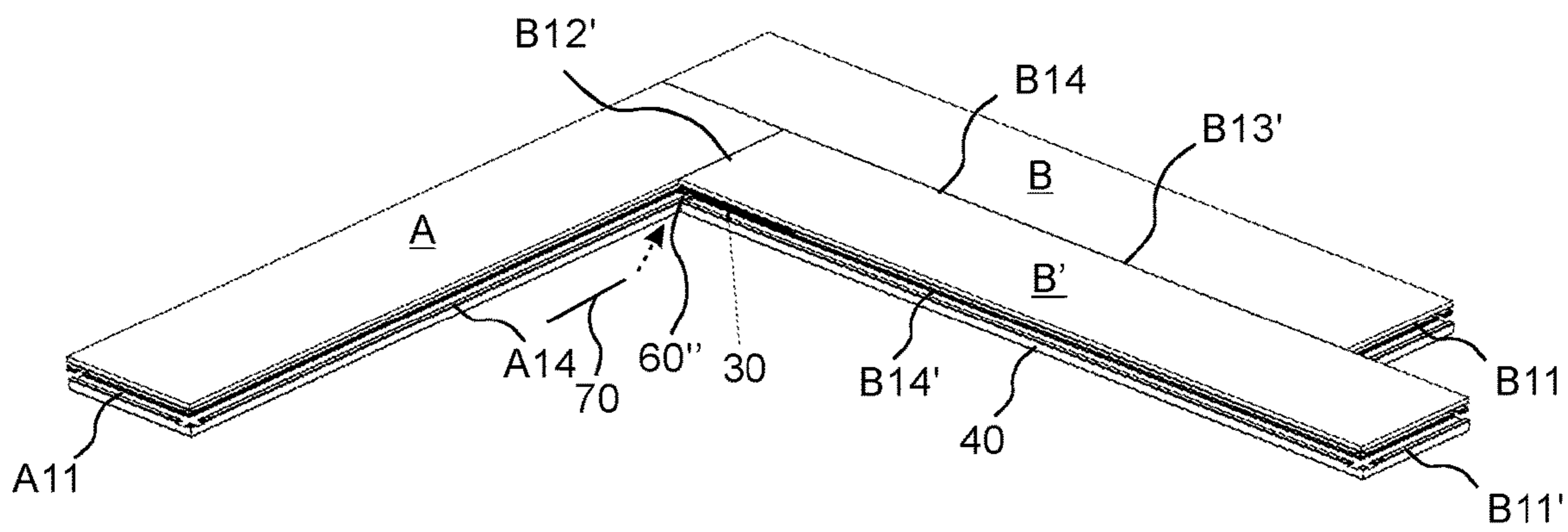

FIG. 8B

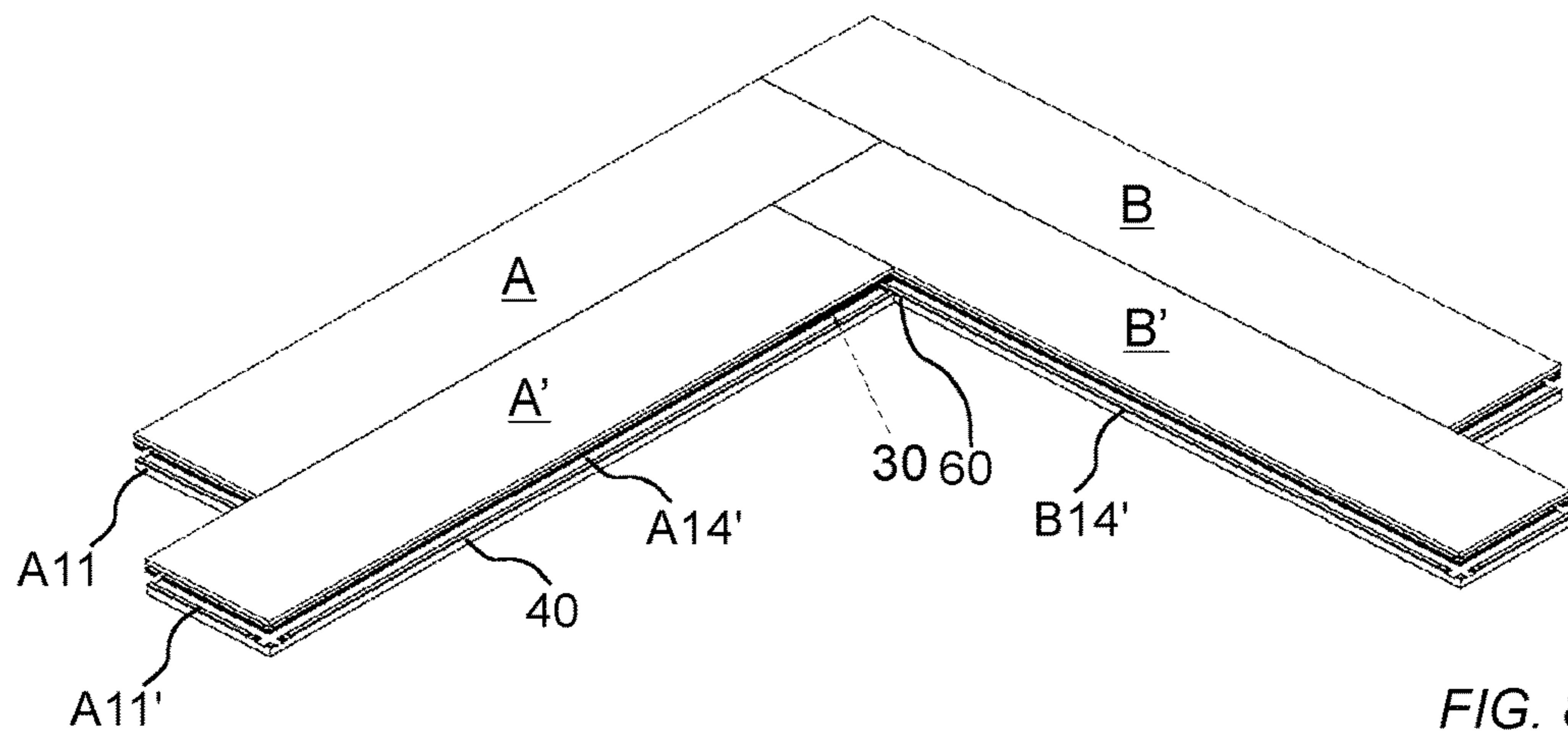

FIG. 8C

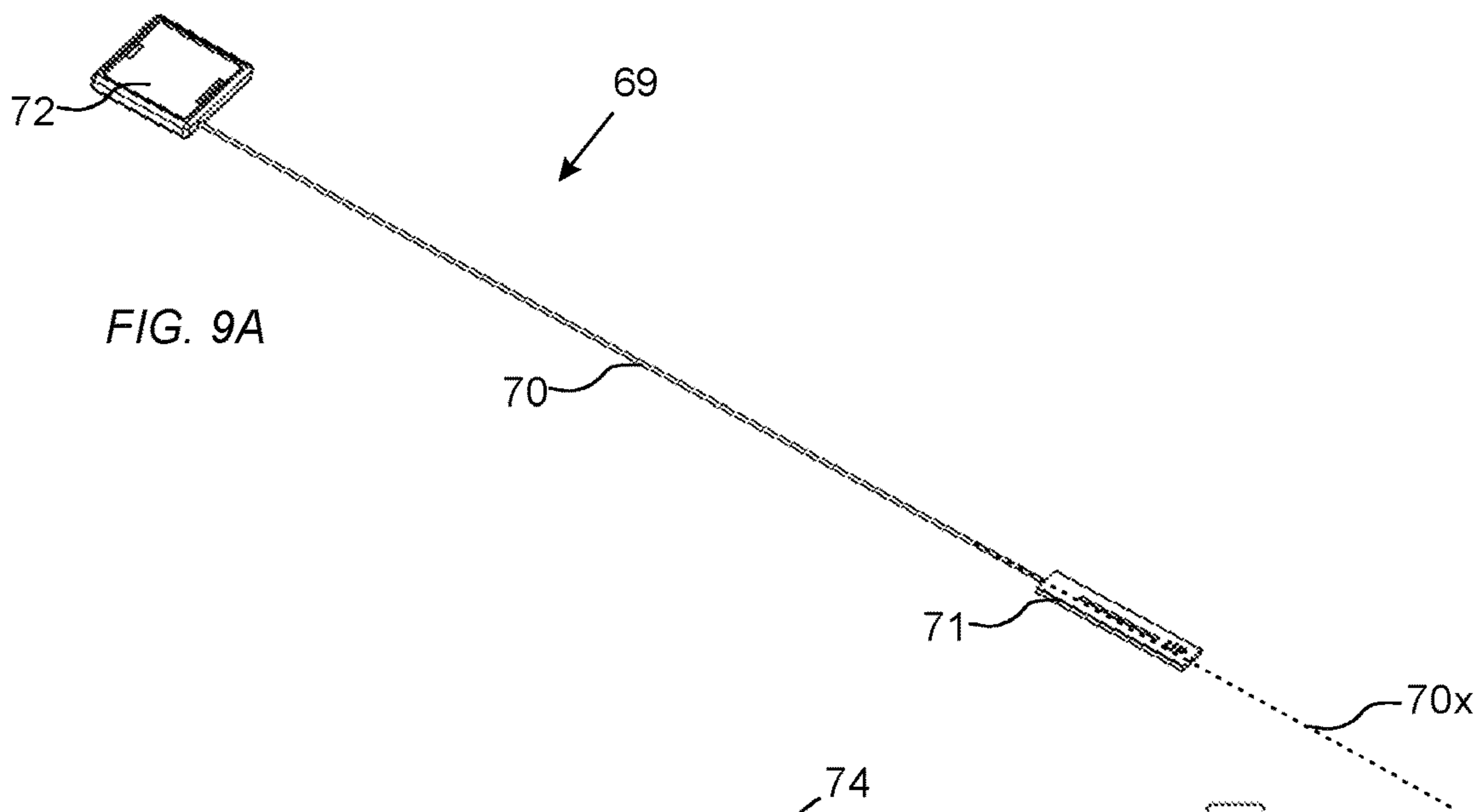

FIG. 9A

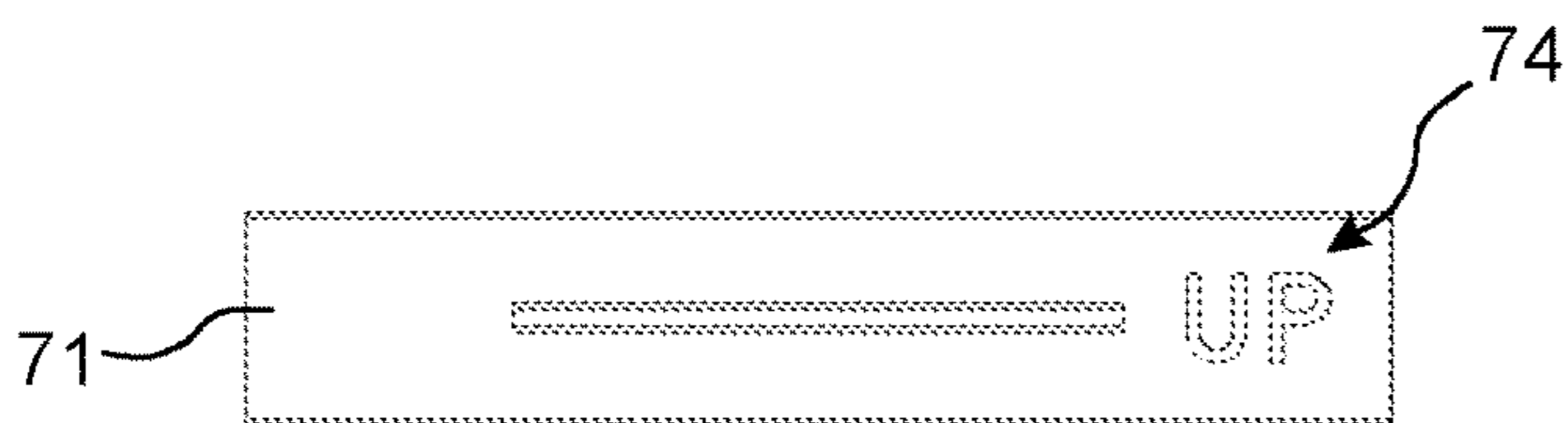

FIG. 9B

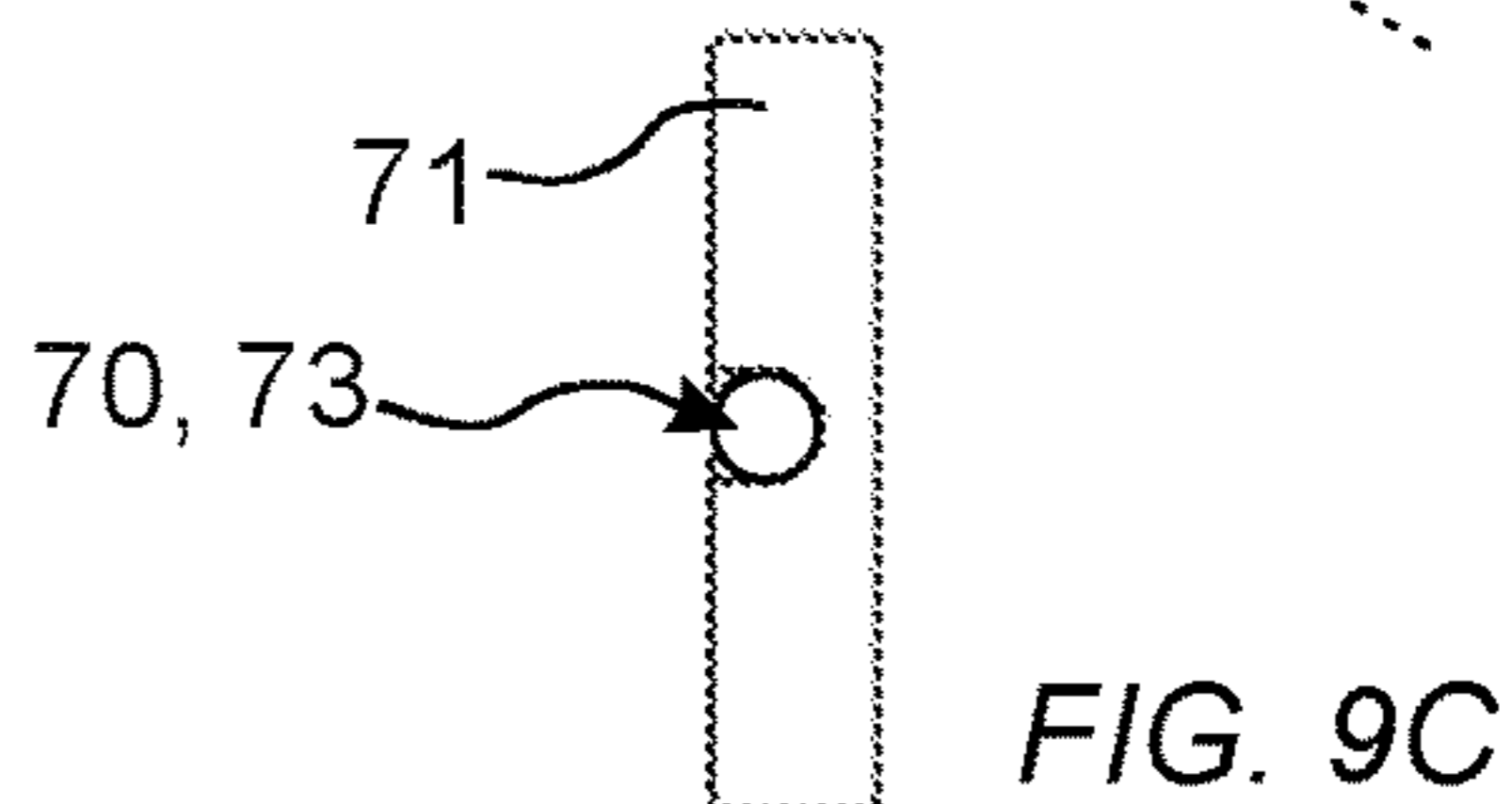

FIG. 9C

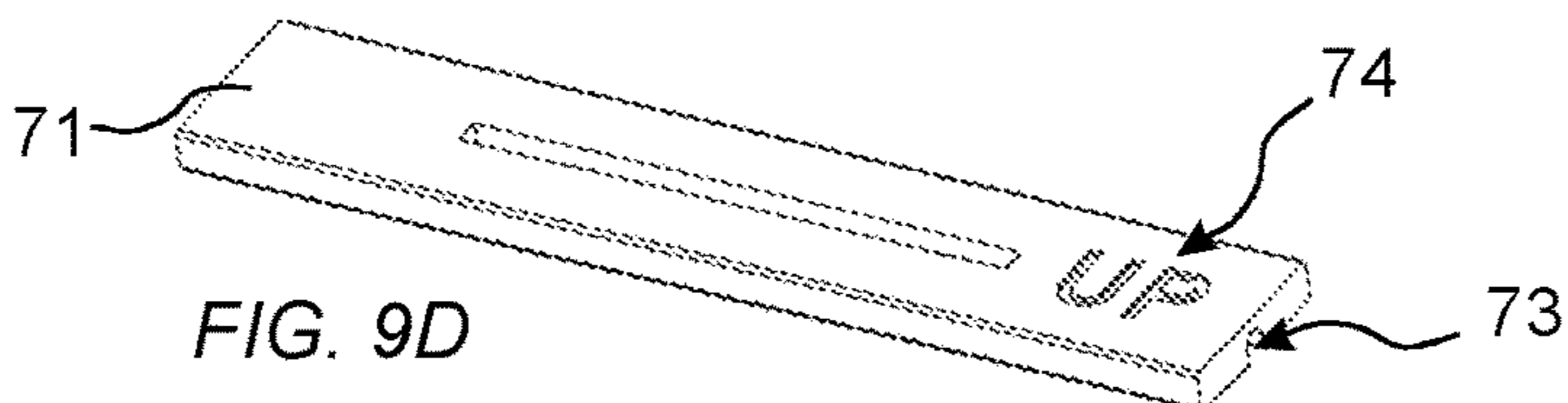

FIG. 9D

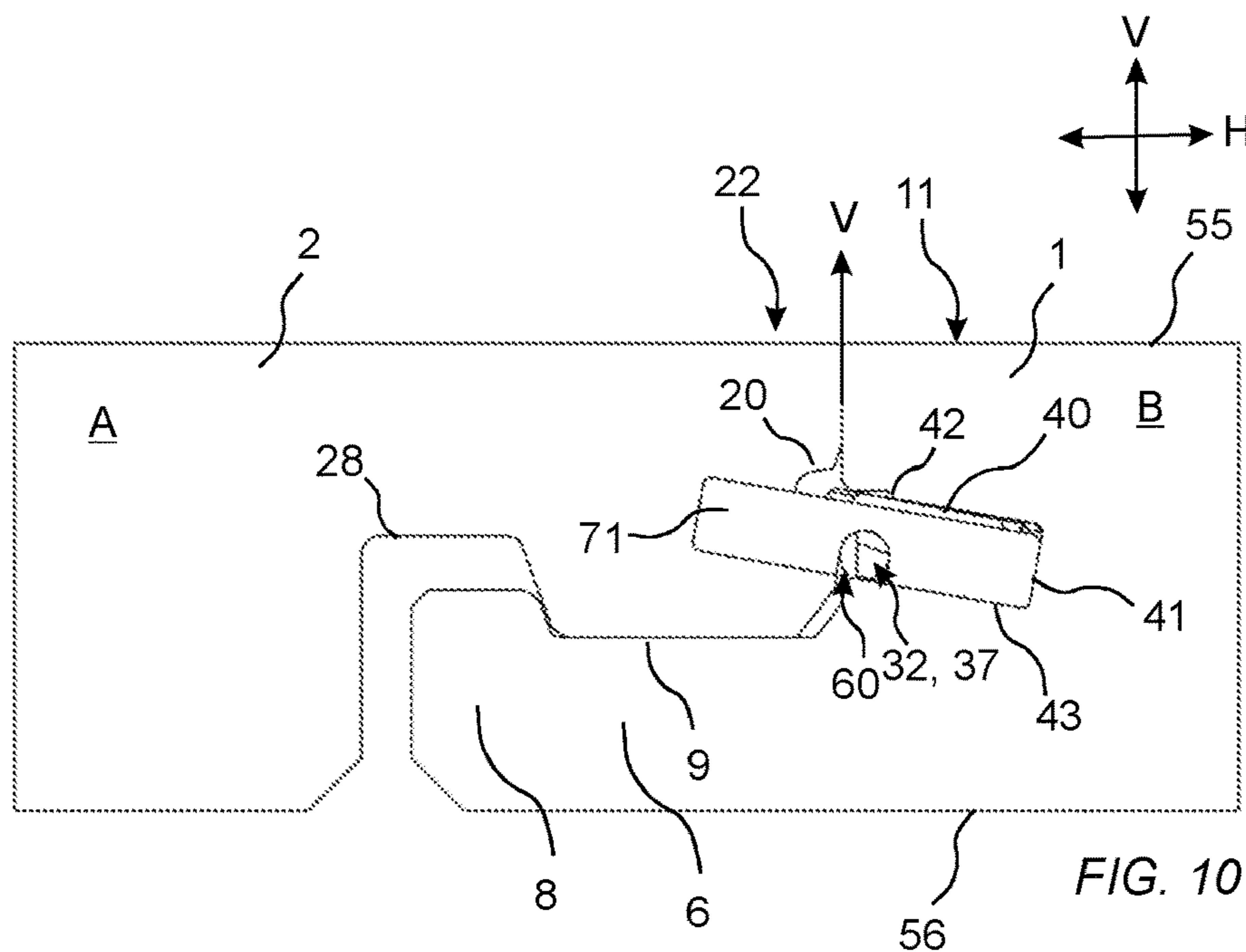

FIG. 10

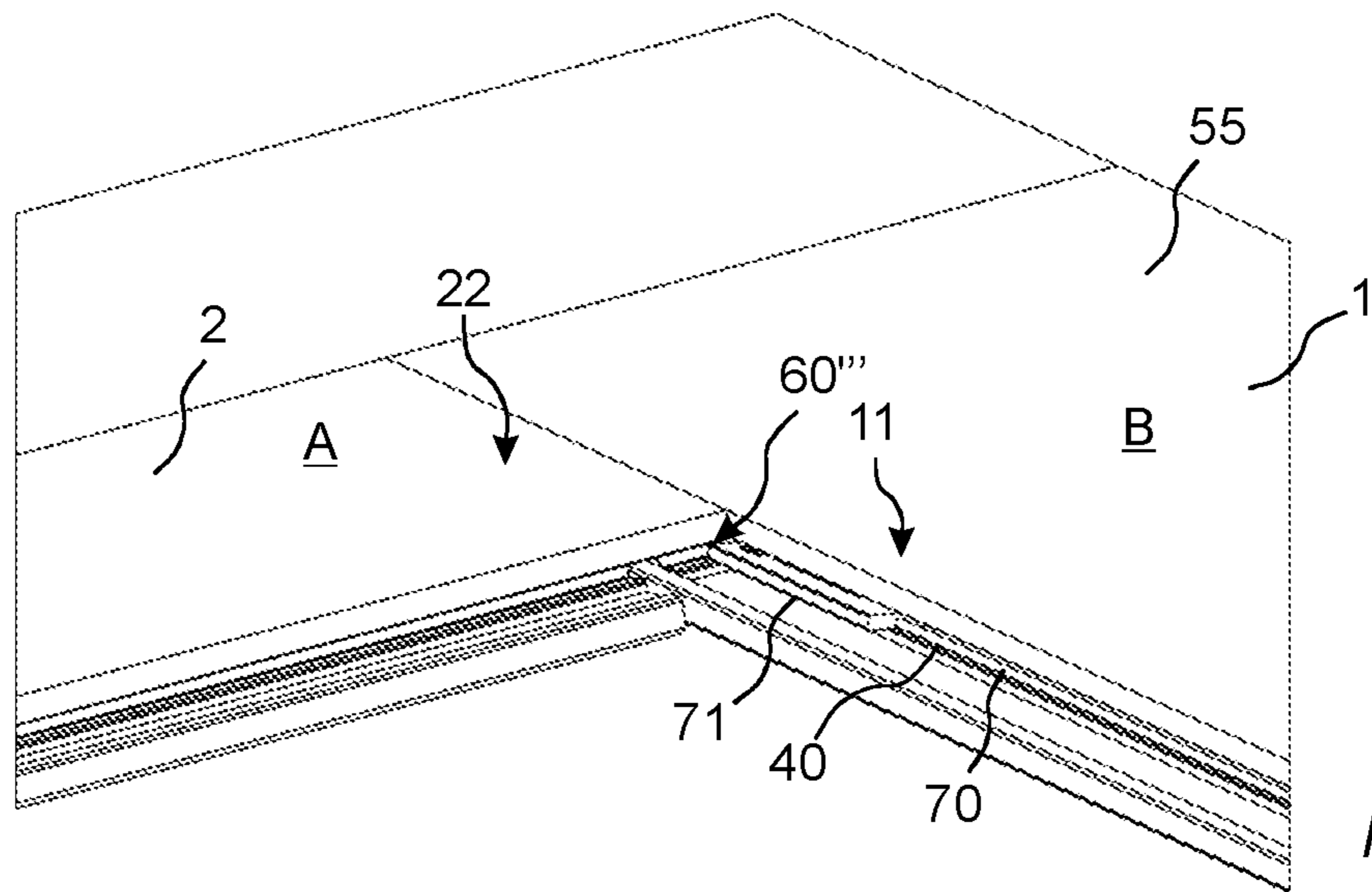

FIG. 11A

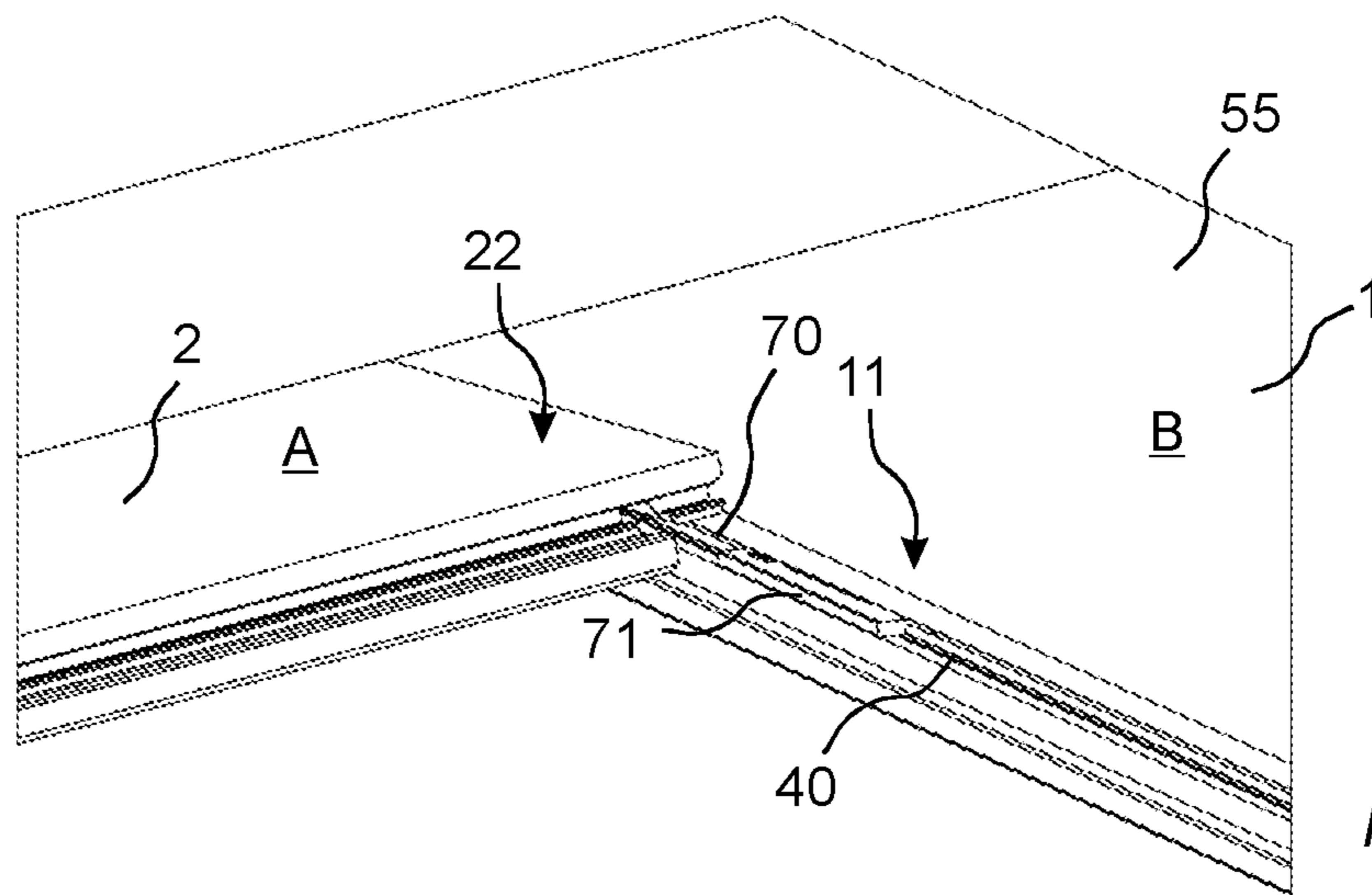

FIG. 11B

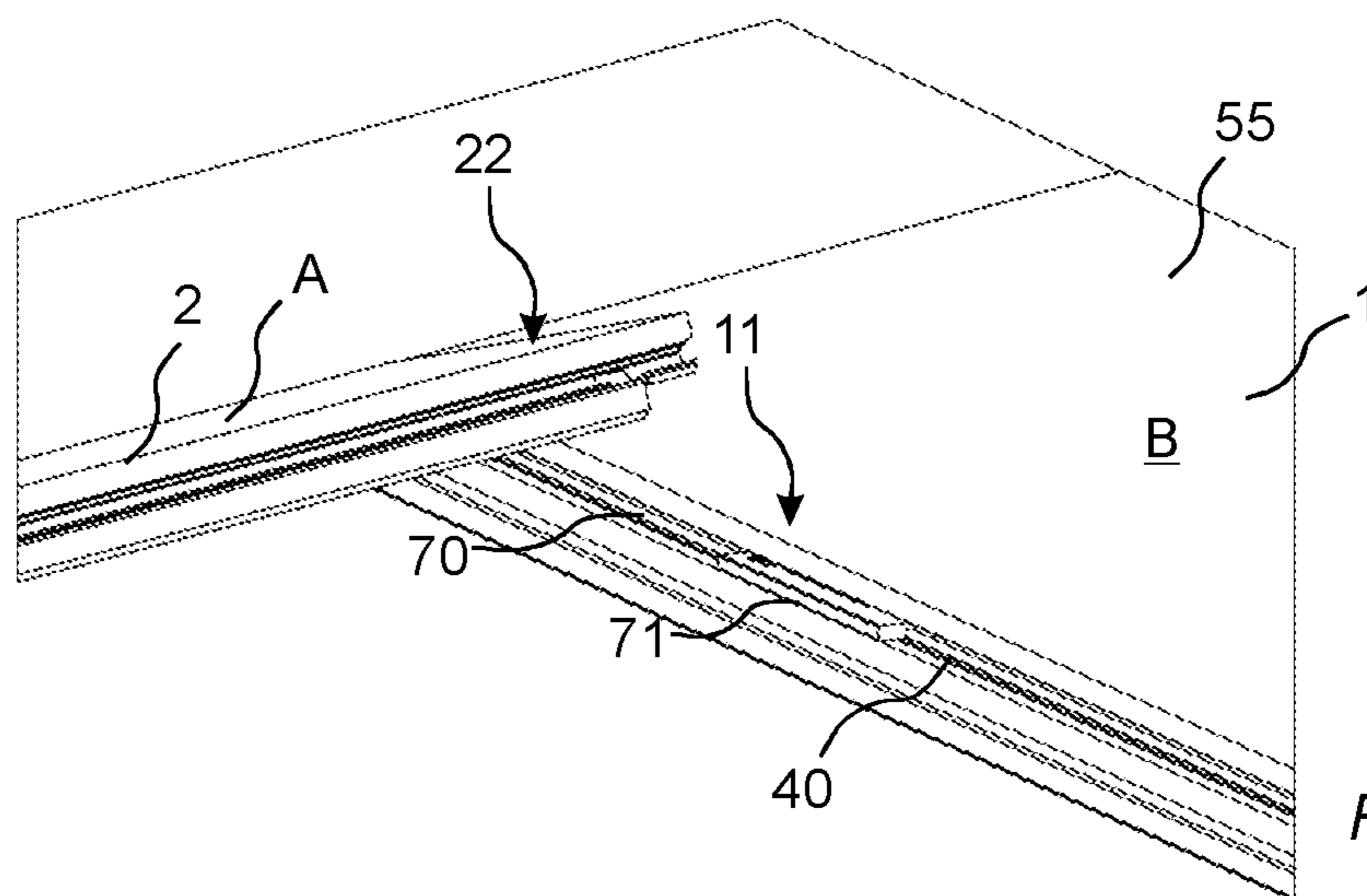

FIG. 11C

UNLOCKING SYSTEM FOR PANELS**CROSS REFERENCE TO RELATED APPLICATIONS**

The present application is a continuation of U.S. application Ser. No. 16/713,373, filed on Dec. 13, 2019, now U.S. Pat. No. 11,060,302, which claims the benefit of Swedish Application No. 1950024-8, filed on Jan. 10, 2019. The entire contents of U.S. application Ser. No. 16/713,373 and Swedish Application No. 1950024-8 are hereby incorporated herein by reference in their entirety.

TECHNICAL FIELD

Embodiments of the present invention relates to a panels such as a building panels, floorboards, wall panels, ceiling panels, furniture components or the like, which are provided with a mechanical locking system.

TECHNICAL BACKGROUND

Building panels provided with a mechanical locking system comprising a displaceable and resilient tongue cooperating with a tongue groove for vertical locking are known and disclosed in, e.g., WO2006/043893 and WO2007/015669. The tongue is a separate part and is made of, e.g., plastic and inserted in a displacement groove at an edge of a panel. The tongue is pushed into the displacement groove during a vertical assembling of the panels and springs back into the tongue groove of an adjacent panel when the panels have reached a locked position.

Further known locking system comprises a tongue provided with, e.g., a wedge element. Two adjacent panels' edges are locked by displacing the tongue along the adjacent edges, see e.g., is disclosed in WO2008/004960.

A known system for unlocking panels comprises, and is disclosed in WO2014/209213.

Although WO2014/209213 provides a well-functioning system, there is still room for improvements.

The above description of various known aspects is the applicant's characterization of such, and is not an admission that any of the above description is considered as prior art.

SUMMARY

It is an object of certain embodiments of the present invention to provide an improvement over the above described techniques and known art. Particularly the ease of assembling and disassembling panels may be improved by embodiments of the inventive concept. Also, the inventive concept may bring about advantages in the manufacturing of the panels, in particular in terms of manufacturing tolerances of the edge-portions of the panels, as will become apparent herein.

At least some of these and other objects and advantages that will be apparent from the description have been achieved by aspects of the inventive concept. In a first aspect, there is provided a set of essentially identical panels, such as building panels, provided with a mechanical locking system comprising:

a displaceable tongue arranged in a displacement groove having a first opening at a first edge of a first panel. The tongue is configured to be displaced in the displacement groove along a displacement axis to attain a locking state wherein a first portion of the tongue cooperates with a first tongue groove having a second opening at a second edge of

an adjacent second panel, for vertical locking of the first and the second edge. A second portion of the tongue is configured to cooperate with the second edge of the adjacent second panel via an elongated element for vertical unlocking of the first and the second edge.

The arrangement may bring about an advantage in that the tolerances necessary to achieve a reliable unlocking mechanism are provided by the tongue and the elongated element.

In one embodiment, a first engagement portion of the second portion is configured to engage with the elongated element and delimits an unlocking groove configured to receive the elongated element such as to cause the tongue to be displaced along the displacement axis to attain an unlocking state for said vertical unlocking of the first and the second edge.

In a further embodiment, a second engagement portion of the second edge is configured to engage with the elongated element and delimits the unlocking groove, preferably the second engagement portion being provided external the first tongue groove, more preferably externally of and below the first tongue groove.

In a yet further embodiment, the first engagement portion and/or the second engagement portion are planar and extend in parallel or substantially in parallel, preferably side by side and in parallel. It may thereby be achieved that the elongated element is not urged in a transverse direction thereof, such as up or down. Also, linear translation of the tongue may be obtained.

In a still further embodiment, the unlocking groove is configured to attain the unlocking state upon receiving an elongated element having a constant cross-sectional width in the longitudinal direction of the elongated element.

The displacement groove may comprise a bottom surface, an upper surface and a lower surface, preferably the lower surface being parallel to the upper surface and/or parallel to the displacement axis of the tongue.

In one embodiment, the second engagement portion extends below a plane of the lower surface.

A dimension in the direction of a normal of a plane of the lower surface, between the lower surface and the first portion, may correspond at least to a maximum diameter of the elongated element, such as a maximum diameter of a portion of the elongated element intended to be received in the unlocking groove.

In one embodiment, a dimension in the direction of the normal of a plane of the lower surface, between the lower surface and the first portion, corresponds at least to a dimension along the displacement axis between the first engagement portion and an outermost point of the tongue.

A dimension in the direction of the normal of the plane of the lower surface, between the said plane and the first portion may correspond at least to a distance, such as a greatest distance, along the displacement axis between the second engagement portion and an outermost point of the tongue in the locking state, preferably the said greatest distance is measured between an outermost point of the second engagement portion and an outermost point of the tongue.

The dimension in the direction of a normal of a plane of the lower surface, between the lower surface and the first portion may be measured between a point on a lower surface of the first portion of the tongue, said point being aligned, in the direction of the normal of the plane of the lower surface, with an uppermost point of the elongated element.

In one embodiment, the second portion and the diameter of the elongated element are configured to cooperate such that the tongue is displaced along the displacement axis at

least to the extent that an outermost point of the second engagement portion and an outermost point of the first portion do not overlap, preferably to the extent that there is provided a play in a horizontal plane between the outermost point of the second engagement portion and the outermost point of the first portion.

The second portion may comprise a chamfered edge portion forming a guiding surface configured to guide the elongated element in the transverse direction of the tongue, preferably a chamfered longitudinal edge portion.

In one embodiment, the second edge comprises a chamfered edge portion for guiding said elongated element towards the tongue.

The elongated element may have a rotationally symmetric cross-section in a transverse plane thereof, by an angle of less than 120 degrees, preferably less than 90 degrees, more preferably being circular.

The locking system may be configured such that in the unlocking state, the elongated element is at least partially arranged in the displacement groove.

An engagement direction may be directed downwards and in parallel with vertical plane formed by an upper part of the first edge and an upper part of the second edge.

In the locking state, the first portion of the tongue may be configured to protrude from the displacement groove and/or from the first edge, such as an upper part thereof, a distance along the horizontal plane, which may be transverse the engagement direction, not greater than the distance between a lower surface of the displacement groove and the first portion of the tongue in the direction of a normal of the lower surface of the displacement groove.

In one embodiment, the unlocking groove is disposed at least partially between the tongue groove and the lower surface of the displacement groove.

In one embodiment, the second engagement portion forms part of a second unlocking surface of the second edge facing a first unlocking surface of the second portion of the tongue. The second unlocking surface may extend in an engagement direction and at least passed a mid-point between the first portion of the tongue and the plane of the lower surface of the displacement groove. The second unlocking surface may extend at least to the plane of the lower surface of the displacement groove. The first and second unlocking surfaces may be planar and/or vertical. Optionally, the first and second unlocking surfaces may each have an extension configured such that the elongated element is not urged to displace in the engagement direction above or below the displacement groove.

The extension of the second portion in a direction along the normal of the lower surface of the displacement groove may exceed the extension of the first portion in a direction along the said normal.

The first engagement portion may be provided at a recess of the tongue. The recess may be provided between the first portion and the lower surface of the displacement groove.

The recess may have a concave shape. An advantage of providing the recess with a concave shape may be that the elongated element maintains a desired position in the unlocking groove, such as during insertion of the elongated element in the unlocking groove and/or during disassembling of the first and second panel.

The first opening and the second opening are preferably horizontally open and a vertical height of the first opening is preferably greater than a vertical height the second opening.

A maximum height of the displacement groove may be greater than a maximum height of the first tongue groove. The maximum height of the first tongue groove may be in

the range of about 20% to about 75% of the maximum height of the displacement groove, preferably in the range of about 20% to about 50% of the maximum height of the displacement groove.

The mechanical locking system may comprise a first locking strip, at the first or the second edge, provided with a first locking element configured to cooperate for horizontal locking with a first locking groove at the other of the first or second edge.

The panels may be floorboards, wall panels, ceiling panels, a furniture component or the like.

The core of the panels may be a wood-based core, preferably made of MDF, HDF, OSB, WPC, plywood or particleboard. The core may also be a plastic core comprising thermosetting plastic or thermoplastic e.g. vinyl or PVC. The plastic core may comprise fillers. The thinner first tongue groove may, for a panel with a core comprising plywood, be easier to arrange at a favorable position in relation to the layers in the plywood core.

The front face, such as an upper surface, of the panels is preferably provided with a decorative layer and the back face is preferably provided with a balancing layer.

The edge of the panels, of which parts of the locking system, such as the first and the second locking strip, the first and the second locking element, the first and the second locking groove, the displacement groove and the first and the second tongue groove, may be made, may be comprised of one or more of the above-mentioned core materials.

In a second aspect, the inventive concept pertains to a kit comprising the set according to any one of the embodiments of the first aspect and an elongated element configured for vertical unlocking of the first and second edge.

In a third aspect, the inventive concept pertains to a method for vertical unlocking a set of essentially identical panels, such as building panels, provided with a mechanical locking system comprising:

a displaceable tongue arranged in a displacement groove having a first opening at a first edge of a first panel, the tongue configured to be displaced in the displacement groove along a displacement axis to attain a locking state wherein a first portion of the tongue is configured to cooperate with a first tongue groove with a second opening at a second edge of an adjacent second panel, for vertical locking of the first and the second edge; and

wherein the method comprises: inserting an elongated element in an unlocking groove delimited by a first engagement portion of the second portion of said tongue and further delimited by a second engagement portion of the second edge of the second panel disposed externally the tongue groove, to thereby cause the tongue to be displaced along the displacement axis to attain an unlocking state for vertical unlocking of the first and the second edge.

In a fourth aspect, the inventive concept pertains to a device **69** for unlocking a mechanical locking system of building panels assembled by means of the mechanical locking system. The mechanical locking system configured for horizontal and vertical locking of adjacent building panels. The locking system comprising at a first edge of a first building a displaceable locking tongue configured to displace in a displacement groove provided in the first edge of the first building panel. The locking tongue being configured to displace between a locking position and an unlocking position. In the locking position, the locking tongue is configured in a protruding position wherein protruding from the displacement groove for cooperating with a tongue groove provided in an adjacent edge of a second adjacent building panel. In the unlocking position, the

5

locking tongue is configured in a retracted position. The unlocking device comprises an elongated element (70) and a positioning element (71). The positioning element is configured to be received in the displacement groove.

Further embodiments and advantages being described in following description and the appended claims.

BRIEF DESCRIPTION OF THE DRAWINGS

The present invention will by way of example be described in more detail with reference to the appended schematic drawings, which shows embodiments of the present invention.

FIG. 1A-1B show cross sections of known locking systems with a separate and displaceable tongue.

FIGS. 2A-2B show a perspective view of panels according to embodiments of the inventive concept.

FIGS. 3A-3B show schematic side-views of panels according to an embodiment of the inventive concept.

FIG. 3C shows a schematic cross-sectional view of panels according to an embodiment of the inventive concept.

FIGS. 4A-4C show cross-sectional views of the panels of FIG. 3A-B.

FIG. 5A shows a perspective view of a displaceable tongue according to an embodiment of the inventive concept.

FIG. 5B shows a top view of details of a displaceable tongue of FIG. 5A.

FIG. 6 shows a schematic view of a short edge of a panel according to an embodiment of the inventive concept.

FIG. 7A-7B shows a schematic illustration of further embodiments of the inventive concept.

FIGS. 8A-8C show a schematic illustration of the embodiments of FIG. 7.

FIG. 9A shows a perspective view of a device for disassembling assembled building panels, according to an embodiment of the inventive concept.

FIG. 9B shows a side view of a positioning element according to an embodiment of the inventive concept.

FIG. 9C shows another side view of the embodiment of FIG. 9B.

FIG. 9D shows a perspective view of the embodiment of FIG. 9B.

FIG. 10 shows a cross view of a positioning element arranged in a displacement groove of a building panel, according to an embodiment of the inventive concept.

FIGS. 11A-11C schematically illustrate a method of disassembling assembled building panels, according to an embodiment of the inventive concept, wherein: FIG. 11A shows two assembled building panels and the device of FIG. 9A arranged in a displacement groove of one of the building panels; FIG. 11B shows at least a portion of the elongated element of the device of FIG. 9A having been inserted in an unlocking groove shown in FIG. 11A; FIG. 11C shows a first and second building panel being disassembled by means of a vertical displacement of a second edge of a second panel relative a first edge of a first panel.

DETAILED DESCRIPTION

A known mechanical locking system for building panels, which comprises a displaceable tongue 30' cooperating with a first tongue groove 20' for vertical locking of a first edge of a first panel 1' with a second edge of a second panel 2' is shown in FIGS. 1A-1B. The tongue 30' is a separate part and is made of, e.g., plastic, and inserted in a displacement groove 40' at the first edge of the first panel 1'. The tongue

6

30' is pushed into a displacement groove 40' during a vertical assembling of the first and the second edges of the panels 1', 2' and springs back into a first tongue groove 20' at the second edge of the second panel 2' when the panels have reached a locked position. A third and a fourth edge of the panels are provided with a locking system, which enables assembling to an adjacent panel (not shown) by an angling movement, to obtain a simultaneous assembling of the first and the second edges and the third and the fourth edges.

Embodiments of the inventive concept are shown in FIGS. 2A-2B, 3A-3C, 4A-4B, 5A-5B, 6, 7A-7B, 8A-8C, 9A-9D, 10, and 11A-11C. A locking system is formed at a first edge 11 of a first panel 1, and a second edge 22 of an adjacent second panel 2 for locking the first 11 and the second edges 22 in a vertical and/or horizontal direction.

FIGS. 2A-2B show an illustration of an embodiment of the inventive concept comprising a mechanical locking system comprising a dedicated unlocking groove 60 configured to receive an elongated element 70 for vertical unlocking of the first and second edges 11, 22.

FIGS. 3A-3B show side views of embodiments of the displaceable tongue 30 during unlocking of a first and a second panel 1, 2.

An upper part of the first edge 11 and an upper part of the second edge 22 may form a vertical plane V.

The second panel 2 with the first tongue groove 20 is lowered in relation to the second panel 2 with the displaceable tongue 30, which is pushed into a displacement groove 40 by the lowered panel 2. The displaceable tongue 30 springs back, and into the first tongue groove 20, when the panels have reached an assembled position, and locks the first 1 and the second 2 panels vertically.

An embodiment of the locking system enables assembling of panels at the adjacent edges by a vertical movement. The locking system is preferably formed by mechanical cutting, such as milling, drilling and/or sawing, of the edges of the panels and provided with a displaceable tongue 30, preferably made of a polymer-based material such as thermoplastic, alternatively the tongue 30 may be made of metal. The displaceable tongue 30 may be bendable and may be provided with protruding flexible parts, such as biasing feathering means. Obtaining small satisfactory tolerances in the forming of the locking system, in particular the machining of the panels, are typically costly and time consuming. Embodiments of the present disclosure may facilitate that manufacturing tolerances of the locking system may be essentially provided by the tongue 30 and the deactivating elongated element 70, such as a stick. The stick may be made of a stiff and bendable material, such as metal. The tongue 30 and the elongated element 70 may thus be manufactured such that the elongated element 70 may cause displacement of the tongue 30 in the unlocking direction to the extent that play dH (See FIG. 4B) in the direction of the plane H, such as a horizontal plane, is provided between the first portion 31 of the tongue 30 and a second engagement portion 25 independent of the tolerances of the first 11 and second edge 22, for vertical unlocking of the first and second edges 11, 22. In some embodiments, dH may be zero. Thereby, embodiments of the inventive concept may provide for improvements in terms of cost-efficiency since it may be less costly to manufacture the tongue 30 and the deactivating elongated element 70 with high precision.

The displaceable tongue 30 is arranged in the displacement groove 40 at the first edge 11 of the first panel 1. The tongue 30 cooperates with a first tongue groove 20, which is formed at the second edge 22 of a second panel 2, for vertical locking of the panel 1, 2. A corresponding configu-

ration may be provided at a first edge **21** of the second panel **2**. A first locking strip **6** with a vertically protruding first locking element **8** is formed in the first edge **11** of the first panel **1**. The locking element **8** cooperates with a first locking groove **28**, formed in the second edge **22** of the second panel **2**, for horizontal locking of the panels **1**, **2**.

The tongue **30** may be displaceable in the displacement groove **40** along a displacement axis A_x corresponding to a locking direction to attain a locking state wherein a first portion **31** of the tongue **30** is configured to cooperate with the first tongue groove **20** having an opening at a second edge **22** of an adjacent panel, such as second panel **2**, for vertical locking of the first edge **11** and the second edge **22**.

The tongue **30** may be displaced in the displacement groove **40**, in particular, a first portion **31** and a second portion **32** of the tongue **30** are configured to be displaced inside the displacement groove **40**. The first **31** and second **32** portions of the tongue **30** may form an integral body. The tongue **30** may be linearly translated in the displacement groove **40**. Linear translation may include a minor amount of non-linear translation, such that the translation is primarily linear.

As shown for instance in FIGS. **3A-3B** and **4A-4B**, the displacement groove **40** comprises a bottom surface **41**, an upper surface **42** which may be disposed adjacent the first portion **31** of the tongue **30**, and a lower surface **43** which may be disposed adjacent the second portion **32** of the tongue **30**. Plane P_x of the lower surface **43** may be parallel to a displacement axis A_x . Consequently, the tongue **30** may be displaced along the displacement axis A_x relative to and/or against the lower surface **43**, optionally also the upper surface **42**. The tongue **30** may be displaced, typically linearly translated, along the displacement axis A_x in a locking direction to attain the locking state and in an unlocking direction to attain an unlocking state, as will be explained herein. Typically, the tongue **30** at least to some extent rests on the bottom surface **43**. Accordingly, the direction of the normal N_y of the plane P_x of the bottom surface **43** thus extends transverse or with a right-angle relative the plane P_x in a direction towards the upper surface **42** of the displacement groove **40**.

The first portion **31** may comprise or constitute an upper and outer portion of the tongue **30** and the second portion **32** may comprise or constitute a lower and outer portion of the tongue **30**. In this context, "upper" may refer to adjacent the upper surface **42** of the displacement groove **40**, correspondingly "lower" may refer to adjacent the lower surface **43** of the displacement groove **40** and "outer" may refer to opposite the bottom surface **41** of the displacement groove **40**.

As shown in FIGS. **3A-4B**, the displacement axis A_x , and thus also the displacement groove **40**, may be inclined an angle φ relative a horizontal plane H . Typically, the plane of the first panel **1** and/or an upper **55** surface and/or a lower **56** surface of the panel may be parallel the horizontal plane H . The upper surface **55** of the panel **1**, **2** may be a visible surface. The displacement groove **40** may be inclined downwards, such as in the engagement direction E , as the displacement groove **40** extends into the first panel **1**, as shown in FIGS. **3A-4B**.

FIG. **3A** shows the tongue **30** in the locking state. In the locking state, at least the first portion **31** of the tongue **30** protrudes outside the displacement groove **40** and at least partially into the tongue groove **20**. The first portion **31** may comprise a protruding tongue nose of the displaceable tongue **30**.

The second portion **32** may or may not protrude outside the displacement groove **40**, typically the second portion **32**

does not or does not substantially protrude from the displacement groove **40** in the locking state and/or the unlocking state.

The first portion **31** may have an extension along the displacement axis A_x exceeding that of the second portion **32**. The second portion **32** may have an extension in the normal direction N_y exceeding that of the first portion **31**.

The tongue **30** further comprises a recess **33**, which may recess inwards underneath the tongue nose of the tongue **30** to form a concavity extending in the longitudinal direction of the tongue **30**, such as the longest extension of the tongue **30**. It follows that there may be a gradual curved transition between the first portion **31** and the second portion **32** as illustrated in FIGS. **3A-B** which curve may have a radius of curvature configured to substantially correspond to a radius of the elongated element **70**. The recess **33** may at least partially surround the unlocking groove **60**.

The second portion **32** of the tongue **30** of the first panel **1**, provided adjacent the first portion **31**, may be configured to cooperate with an edge portion of an adjacent second panel **2** for vertical unlocking of the first **1** and second **2** panels. The second portion **32** of the tongue **30** may be provided above or below the protruding tongue nose, preferably below the first portion **31** in the engagement direction, such as downwards in FIGS. **3A-3B**, **4A-4B**. More in particular, the second portion **32** is configured to cooperate with a portion of the second edge **22** via an elongated element **70** which may abut the second portion **32** and the second edge **22** simultaneously. The second portion **32** comprises a first engagement portion **34** and the second edge **22** comprises a second engagement portion **25** for engaging the elongated element **70**.

The mechanical locking system comprises an unlocking groove **60** for vertical unlocking of the first edge **11** of the first panel **1** and the second edge **22** of an adjacent panel, such as the second panel **2**.

As shown in FIGS. **2A-B**, the first edge **11** and the second edge **12** of the first panel **1** may be the short edges of a panel, such as the first panel **1**, and the third edge **13** and the fourth edge **14** may be the long edges of a panel, such as the first panel **1**. This may apply mutatis mutandis for an adjacent panel, such as the second panel **2** having respective first **21**, second **22**, third **23**, and fourth edges **24**.

The unlocking groove **60** is delimited by surfaces of elements, such as two, three or four surfaces, provided by portions of one or more of the first portion **31** of the tongue **30**, the second portion **32** of the tongue **30**, the second edge **22** of the second panel **2** and the lower surface **43** of the displacement groove **40**.

Thus, the second portion **32**, the second edge **22** and the lower surface **43** of the displacement groove **40** may form the unlocking groove **60** configured to receive the elongated element **70**.

Typically, the unlocking groove **60** is delimited in the normal direction N_y by means of the first portion **31** of the tongue **30**, such as the protruding tongue nose, and further delimited by the second portion **32** of the tongue **30** and by a portion of the second edge **22** of the second panel **2**.

The unlocking groove **60** is configured to receive an elongated element **70** such that the tongue **30** is displaced along the displacement axis in an unlocking direction, to attain an unlocking state as shown in FIG. **3B**.

Upon insertion of the elongated element **70** in the unlocking groove **60**, the tongue **30** is thus caused to displace or linearly translate inside the displacement groove **40** in response to the insertion, i.e. under the action of the elon-

gated element 70 engaging the tongue 30 and urging the tongue 30 to displace along the displacement direction Ax.

The second portion 32 of the tongue 30 comprises a first engagement portion 34 for direct engaging or cooperating with the elongated element 70, such as with an outer circumference of the elongated element 70.

The second edge 22 of the second panel 2 may comprise a second engagement portion 25 (See FIG. 4A) provided exterior the tongue groove 20, preferably below the tongue groove 20. The second engagement portion 25 may provide for direct engaging or contact with the elongated element 70, such as a circumference of the elongated element 70. The first edge 11 of the first panel 1 may comprise a first engagement portion 34. The first engagement portion 34 may provide for direct engaging or contact with the elongated element 70, such as a circumference of the elongated element 70.

The first engagement portion 34 and/or the second engagement portion 25 may be planar and/or may extend vertically. The first engagement portion 34 and the second engagement portion 25 may extend side by side and/or in parallel. Preferably, the first engagement portion 34 and the second engagement portion 25 are planar and extends side by side in parallel.

During a vertical assembling of the panels, the second engagement portion 25 may be configured to engage with the first portion 31 of the tongue 30 such as to push back the tongue 30 in an unlocking direction along the displacement axis Ax into the displacement groove 40.

The unlocking groove 60 may be configured such that the extension thereof in the direction Ny of the normal corresponds to at least the distance between the first engagement portion 34 and the second engagement portion 25 in the unlocking position as shown in FIG. 4B.

Typically, in the locking state, the unlocking groove 60 is configured such that the first engagement portion 34 and the second engagement portion 25 are provided to have an extension above the lower surface 43 of the displacement groove 40. For example, the first engagement portion 34 and the second engagement portion 25 are provided to have an extension at least at a distance above the lower surface 43 of the displacement groove 40 substantially corresponding to half the distance between the first and second engagement portions 34, 25 in the unlocking state or for example the first engagement portion 34 and the second engagement portion 25 are provided to have an extension at least at a distance above the lower surface 43 of the displacement groove 40 substantially corresponding to half the distance between the plane Px and the first portion 31 of the tongue 30 in the Ny direction inside the unlocking groove 60. The second engagement portion 25 may have an extension below a first opening of the displacement groove 40 at the first edge 11.

The second portion 32 of the tongue 30 may be disposed exterior the tongue groove 20 in the locking state and/or unlocking state.

In particular, the first engagement portion 34 may be disposed exterior the tongue groove 20 in the locking state and/or in the unlocking state.

The unlocking groove 60 may be configured such that the tongue 30 is displaced in an unlocking direction to attain an unlocking state upon receiving the elongated element 70 which is preferably rotational symmetric, such as rotational symmetric under an angle of 120, 90, 72, 60, 45, 36, 30 degrees, preferably rotational symmetric under an angle of 120, more preferably under 90, most preferred being circular.

This arrangement brings about several advantageous effects, including that the elongated element 70 can be inserted in the unlocking groove 60 with reduced frictional resistance which may otherwise cause bending of the elongated element 70.

Further, in the unlocking state when the respective first and second engagement portions 34, 25 are engaged with engagement element 70, the arrangement provides the function of a needle bearing and thus functions as a needle bearing as the second panel 2 is displaced in a direction opposite the engagement direction E, such as a vertical direction, causing the elongated element 70 to rotate or slide against the first engagement portion 34 and/or the second engagement portion 25.

It should be appreciated that as the angle of rotational symmetry decreases the effective contact surfaces, i.e. frictional surfaces, between the elongated element 70 and the respective engagement portions 34, 25 are reduced. Accordingly, in a preferred embodiment the elongated element 70 has a circular cross section in a transverse direction thereof, such as the shortest extension. In this embodiment, the circumference of the elongated element 70 may be tangent with the first and second engagement portions 34, 25 only along a respective incremental contact surface of the first and second engagement portions 34, 25. In other words, the circumference of the elongated element 70 and surfaces of the locking groove 60, i.e. the lower surface 43, the first and second unlocking surfaces 34', 25' of the locking system may substantially not be parallel in a transverse T plane of tongue 30, with exception for the contact surfaces.

Embodiments of the disclosed inventive concept enable a deactivating elongated element 70, such as a round stick, or substantially round stick to be used for unlocking the first and second edge 11, 22.

Thus, embodiments of the disclosed inventive concept may provide for synergistic effects; by providing the unlocking groove 60 exterior the tongue groove 20, the use of a deactivating element which substantially round or round, preferably circular, to be used for unlocking the first and second edge 11, 22 is facilitated. The round shape of the deactivating elongated element 70 may substantially reduce frictional forces associated with disassembling of the panels, such as the first and second panels 1, 2 and thus may facilitate easy vertical disassembling.

The longitudinal length of the elongated element 70, such as the longest extension thereof, may correspond to at least a short side of the panel 1 and/or the length of the first edge 11 and/or in some embodiments a length sufficient to cause the entire length of the tongue 30 to attain the unlocking state, such as if the first edge 11 corresponds to a long side of a panel configured to form part of a herringbone-pattern floating floor, as will be described herein. In such case, the tongue 30 may optionally extend only in a portion of the displacement groove 40 of the long side of such panel (see FIGS. 7A-7B and 8A-8C).

The first engagement portion 34 and second engagement portion 25 may abut or may be arranged flush with each other or may be spaced apart by a distance Δx in the locking state, as shown e.g. in FIG. 4A.

Referring to FIGS. 4A-4B, the locking system of FIGS. 3A-3B are shown more in detail. FIG. 4A illustrates the panels in locking state and FIG. 4B the unlocking state. As derivable from FIGS. 4A-4B, the displacement groove 40 comprises a bottom surface 41, an upper surface 42 and a lower surface 43, the lower surface 43 being parallel a displacement axis Ax of the tongue 30. Thus, the tongue 30 may displace and/or linearly translate parallel the lower

11

surface **43**. The displacement axis Ax may be parallel the plane Px of the lower surface **43**. As the tongue displaces in the locking direction and the unlocking direction respectively, the tongue **30** may be displaced along the displacement axis Ax . The tongue **30** may be displaced against or along the lower surface **43** and/or upper surface **42** of the displacement groove **40**.

A normal Ny of the plane Px extends in a direction transverse the plane Px as shown in FIGS. **4A-4B**.

In the locking state, the first portion **31** may be wedged between the upper surface **42** of the displacement groove **40** and a lower surface of the tongue groove **20**, as shown in FIG. **4A**.

An upper surface and/or lower surface of the tongue **30** may be substantially planar, or planar.

The first portion **31** of the tongue **30** may extend essentially along the displacement axis Ax , and may optionally have a substantially constant thickness in the direction of the normal Ny .

As schematically shown in FIG. **4B**, a dimension Dy in the direction of the normal Ny may be measured between the plane Px and the first portion **31**, such as an underside of the protruding tongue nose.

Dy may be measured in the unlocking groove **60** in unlocking state.

Dy may correspond at least to a maximum diameter D_{max} of the elongated element **70**.

The dimension Dy in the direction of the normal Ny of the plane Px , between the lower surface **43** and the first portion **31**, may correspond at least to a dimension Dx along the displacement axis Ax between the first engagement portion **34** and an outermost point **31a** of the tongue **30**.

As derivable from FIG. **4A** illustrating the locking state, the dimension along the displacement axis Ax between the outermost tip point **31a** of the tongue **30** and the outermost point of the second engagement portion **25**, is denoted Dax . By the outermost tip point **31a** of the tongue **30** is meant in a direction away from the first edge **11** in a direction along the horizontal plane H . By outermost point of the second engagement portion **25** is meant in a direction away from the second edge **22** in a direction along the horizontal plane H . It follows that in order for the tongue **30** to obtain an unlocking state, i.e. such that the second engagement portion **25** and the tip point **31a** do not overlap in a direction along the engagement direction E , the tongue **30** should to displace at least a distance Dax in the unlocking direction along the displacement axis Ax . When the second engagement portion **25** and the tip point **31a** do not overlap, the tongue is in the unlocking position and the second edge **22** of the second panel **2** may be disassembled from the first panel **1** by means of a displacement of the second edge in a direction being opposite the engagement direction E , i.e. a vertical displacement. This means the first edge **11** and the second edge **22** may essentially not displace horizontally relative each other during the vertical displacement, as shown in FIG. **2B**, in other words, the horizontal relationships between features of the first edge **11** and the second edge **22** may not change during the disassembling. Therefore, starting from the locking state shown in FIGS. **3A** and **4A**, for unlocking the mechanical locking system it may suffice to displace the locking tongue **30** such that an outermost point of second engagement portion **25** and the outermost tip point **31a** do not overlap in a direction along the engagement direction E when the first and second panel **1**, **2** are adjacent as shown in FIGS. **3A** and **4A**.

In some embodiments, there may be no play in the horizontal plane H , between the second engagement portion

12

25 and the tip point **31a**. As derivable from FIG. **4A**, dimension Dax is indicated as being measured from approximately half the extent of the second engagement portion **25** in order to provide play dH , however if the tongue is to be displaced such that there is zero play, Dax may be measured as the shortest distance between along the displacement axis Ax between the outermost tip point **31a** of the tongue **30** and the second engagement portion **25**, as illustrated in FIG. **4C**.

Consequently, a minimum cross-sectional diameter D_{min} of the elongated element **70** may displace the tongue **30** at least the distance Dax along the displacement axis Ax , i.e. in the unlocking direction.

Accordingly, the unlocking groove **60** may be configured such that the tongue **30** is displaced in the unlocking direction a distance Dax in response to receiving an elongated element **70** of diameter D_i , which may be a constant cross-sectional diameter, such that the tongue **30** assumes the unlocking state.

In particular, in the locking state, the distance Δx between the first engagement portion **34** and the second engagement portion **25** may be configured such that the tongue **30** is displaced in the unlocking direction along the displacement axis Ax a distance Dax in response to receiving an elongated element **70** of diameter D_i , which may be constant cross-sectional diameter. The distance Δx may be measured along the plane H .

More in particular, the locking groove **60** may be configured such that when the distance between the first engagement portion **34** and the second engagement portion **25** essentially equals the diameter D_i of the elongated element **70**, the tongue has been caused displace the distance Dax along the displacement axis Ax in response to the unlocking groove **60** receiving of the elongated element **70**.

In the locking state, a dimension along the displacement axis Ax between the first engagement portion **34** and an outermost point of the second engagement portion **25** may be greater than Dx .

The displacement groove **40** may be inclined by an angle φ relative the plane of the panels, such as the first panel **1** as shown in FIGS. **4A-4B**. Thus, the displacement axis Ax and the plane of the lower surface Px are inclined in respect of the plane H , such as a horizontal plane. An upper surface **55** of the panel **1** and/or a lower surface **56** of the panel **1** may be parallel the plane H . This entails that as the tongue **30** translates along the displacement axis Ax there may be a certain ratio between downwards movement and sideways movement of the tongue **30**. For example, the tongue may be displaced the distance Dax in the displacement direction Ax ; the sideways movement, typically horizontal, of the tongue **30** then corresponds to $Dax \cdot \cos(\varphi)$, and the downwards movement corresponds to the $Dax \cdot \sin(\varphi)$. It follows that D_i is preferably equal to or greater than the sum of Δx and $Dax \cdot \cos(\varphi)$, optionally greater by a margin corresponding to the dimension of the play dH . In a non-limiting example, φ may be between 5° and 45° , such as between 10° and 30° , such as about 10° , 20° or 30° .

In the locking state, the first portion **31** of the tongue **30** may be configured to protrude from the displacement groove **40** and/or from the first edge **11** a distance along a direction in the H plane equal to or less than the cross-sectional width D_i of the elongated element **70**.

In the locking state, the first portion **31** of the tongue **30**, such as the outermost point **31a**, may be configured to protrude from the displacement groove **40** and/or from the first edge **11** a distance along a direction in the H plane equal

13

to or less than the distance between a lower surface **43** of the displacement groove **40** and the first portion **31** in the direction of the normal N_y .

The unlocking groove **60** may be disposed at least partially between the tongue groove **20** and a lower surface **43** of the displacement groove **40**.

The second engagement portion **25** may extend at least at a mid-point between the first portion **31** of the tongue **30** and the plane P_x of the lower surface **43** of the displacement groove **40**, preferably the second engagement portion **25** extends at least to the plane P_x of the lower surface **43**.

The extension of the second engagement portion **25** in the normal direction N_y may be greater than the corresponding extension of the first engagement portion **34**.

The second engagement portion **25** may extend along or inside the vertical plane V .

The second engagement portion **25** may be stationary during displacement of the tongue **30** along the displacement axis A_x in the unlocking direction.

The unlocking groove **60** may be configured such that insertion of the elongated element **70** therein urges the unlocking groove **60** to expand by means applying force on the first engagement portion **34** in the unlocking direction.

The first portion **31** of the tongue **30** may comprise an outer and upper portion of the tongue **30** facing in a direction towards the upper surface **42** of the displacement groove **40**. The second portion **32** of the tongue **30** may comprise an outer and preferably lower portion of the tongue **30** facing in a direction towards the lower surface **43** of displacement groove **40**.

The elongated element **70** may have a longitudinal length corresponding to at least the length of the first **1** and/or second edge **22**, such as a respective short edge of the first **1** and/or second panel **2**. Alternatively, the elongated element **70** may have a longitudinal length corresponding to at least the length of the tongue **30** in the longitudinal direction L thereof, as indicated in FIG. **5A**.

The locking groove **60** may form a needle bearing with the elongated element **70** in the unlocking state and may thus act as a needle bearing during disassembling of the panels in a direction opposite the engagement direction, typically vertical and upwards movement of the second panel **2** as shown in FIGS. **2A-B**.

The diameter of the elongated element **70** may be in the range of 0.5 to 3 mm, such as 0.8 to 1.5 mm, preferably about 1.1 mm.

The thickness of the panels **10**, **20** may be in the range of about 3 mm to about 10 mm, and preferably in the range of about 4 mm to about 8 mm.

The mechanical locking system comprises a first locking strip **6**, at the first or the second edge **11**, **22**, provided with a first locking element **8** configured to cooperate for horizontal locking with a first locking groove **28** at the other of the first **11** or second edge **22**.

FIG. **3C** shows a cross section of a third edge **13** of the first panel **1** and a fourth edge **304** of a third panel **3**. The mechanical locking system at the third **13** and the fourth edge **304** comprises a second tongue **29** at the fourth edge **304** configured to cooperate for vertical locking with a second tongue groove **12** at the third edge **13**. The third edge **13** is provided with a protruding second locking strip **16** with a second locking element **18** configured to cooperate for horizontal locking with a second locking groove **26** at the fourth edge **304**. A second upper surface **19** of the second locking strip **16** is in contact with a lower surface of the second tongue **29** for locking in the vertical direction. The shown mechanical locking system at the third **13** and the

14

fourth edge **304** is configured to be locked by an angling motion. The second upper surface **19** is positioned in a horizontal plane **49**. The embodiment in FIG. **3C** is exemplary, other mechanical locking systems are conceivable at the third edge **13** and the fourth edge **304**.

An upper surface **9** of the first locking strip **6** may be provided in a same plane **49** as an upper surface **19** of the second locking strip **16**.

The mechanical locking system at the third **13** and the fourth edge **304** may be configured to be assembled by an angling motion, such as a pivoting displacement about the fourth edge **304**.

The mechanical locking system at the first **11** and the second edge **22** may be configured to be assembled by a vertical motion.

The mechanical locking system at the first **11** and the second edge **22** may be configured to be assembled by a vertical motion, such as a vertical motion of the second edge **22** of the second panel **2** in the engagement direction E (see FIG. **3A**) relative the first panel **1**.

The panels may be floorboards comprising a wood fibre-based core, such as HDF, or a core comprising thermoplastic, such as PVC.

The tongue **30** may comprise a chamfered end portion **36** as illustrated in FIGS. **5A-5B**. The end portion **36** may be a longitudinal L end portion. In particular, the second portion **32** of the tongue **30** may comprise a chamfered end portion **36** forming a guiding surface **37** extending in the longitudinal and transverse direction of the tongue **30**. The second portion **32** of the tongue **30** may have a longitudinal L edge and a transverse edge as shown in FIG. **5A**. A transition between the longitudinal edge and the transverse edge of the second portion **32** and/or a corner of the second portion **32** between the longitudinal edge and the transverse edge of the tongue **30** may comprise the chamfered end portion **36**. Thereby forming the guiding surface **37** extending in the longitudinal and transverse direction of the tongue **30**.

The guiding surface **37** may be configured to guide the elongated element **70** in the transverse T direction of the tongue **30** as the elongated element **70** is inserted in the unlocking groove **60** in a longitudinal direction of the tongue **30**.

As also shown in FIG. **5A**, the tongue **30** may comprise biasing means **38** configured to bias the tongue **30** to displace along the displacement axis A_x in the locking direction. The biasing means **38** may be in the form of resilient feathers which may be formed integrally with the tongue **30**. The biasing means **38** may be configured to abut at least the bottom surface **41** of the displacement groove **40**.

As shown in FIG. **6**, the second edge **22** may comprise a chamfered edge portion **36'** for guiding the elongated element **70** in the longitudinal L direction of the panel **2** towards the unlocking groove **60**.

The panel **1**, **2** may have a longitudinal L edge and a transverse edge as shown in FIG. **6**. A transition between the second edge **12**, **22** and the third edge **13**, **23** and/or a corner between the second edge **12**, **22** and the third edge **13**, **23** may comprise the chamfered end portion **36**. Thereby forming the guiding surface **36'** extending in the longitudinal L and transverse T direction of the panel **1**, **2**.

In one embodiment shown in FIGS. **7A-7B** and **8A-8C**, an embodiment of the inventive concept is configured to be applied in panels intended to be arranged in a herringbone pattern.

In a non-limiting example, such herringbone pattern may comprise two types of panels. An A-type panel and a B-type panel. The A-type panel and the B-type panel may mirror

15

each other and/or be counter images of each other, as shown in FIG. 7 where FIG. 7A shows an A-type panel and FIG. 7B shows a B-type panel.

The A-type panel and the B-type panel may each comprise a short edge A11, A12, B11, B12 and a long edge A13, A14, B13, B14, wherein a long edge, such as A14, B14 may comprise a shape corresponding to the first edge 11 of the first panel 1 as explained above, for example in relation to FIGS. 3A-3B. A short side edge, such as A12, B12 may be edges corresponding to the second edge 22 as explained in relation to FIGS. 3A-3B. However, only a portion of the long edge, such as long edges A14, B14, comprises the displaceable tongue 30, as illustrated in FIGS. 7A-7B and 8A-8C.

One of the respective short sides of panel A and B, such as A11 and B11 or A12 and B12 may comprise an edge corresponding to the third edge 13 as explained with reference to FIG. 3C and the other edge may correspond to that of the fourth edge 304 as explained with reference to FIG. 3C.

A further long side, such as A13 and/or B13 may comprise a shape corresponding the fourth 304 edge as explained with reference to FIG. 3C such that the tongue 29 of a panel, such as panel A' or B' is received in the displacement groove 40 of the adjacent panel, such as panel A or B, as shown in FIGS. 8B-8C. It follows for example that panel B' may be assembled in locking position with panel A by means of vertical displacement of the second edge B12' i.e. the short side of panel B' relative the fourth edge A14, i.e. the long side of panel A.

It is thereby achieved that the herringbone pattern can be laid in part by means of vertical engagement to form a braid. It is further achieved that panels of the herringbone pattern may be disengaged by rotation and/or vertically instead of lateral sliding. This vastly facilitates ease of both assembling and disassembling of the floating floor.

In a non-limiting example, a herringbone pattern, such as the one shown in FIGS. 8A-8B, may be disassembled by means of a method comprising one or more of: providing the elongated element 70; inserting the elongated element 70 in a first unlocking groove, such as 60", between a second edge, such as B12', of a first panel, such as B', and a fourth edge, such as A14, of an adjacent second panel, such as A, to thereby vertically unlock the second edge of the first panel and the fourth edge of the second panel; pivoting or angling the said first panel to thereby horizontally unlock a third edge, such as B13', of the first panel and a fourth edge, such as B14, of an adjacent third panel, such as B; removing the first panel;

inserting the elongated element 70 in a second unlocking groove, such as 60", between a second edge, such as A12, of the second panel and a fourth edge, such as B14, of the third panel to thereby vertically unlock the second edge of the second panel and the fourth edge of the third panel; removing the second panel.

FIG. 9A shows a perspective view of a device 69 for disassembling assembled building panels, such as the building panels shown in FIGS. 8A-8C. The device of FIG. 9A may be particularly suitable for disassembling building panels assembled to form a herringbone pattern, such as by means of the mechanical locking system of the first panel 1 and the second panel 2 as explained in relation to FIGS. 3A, 3B, 4A and 4B

FIG. 9B shows a side view of the positioning element 71 according to an embodiment of the inventive concept.

The positioning element 71 may comprise visual indication means 74, such as a text and/or sign indicating an

16

intended orientation of the positioning element in the displacement groove. The visual indication means may facilitate ease of use. The visual indication means may facilitate proper function of the device during use.

FIG. 9C shows another side view of the embodiment of FIG. 9B. The positioning element may comprise a through-hole 73, extending from one side to an opposite side of the positioning element, preferably in a longitudinal direction of the positioning element.

FIG. 9D shows a perspective view of the embodiment of FIG. 9B.

FIG. 10 shows a cross view of a positioning element arranged in a displacement groove of a building panel 1, which may be a Type-A or Type-B panel, according to an embodiment of the inventive concept. For ease of explaining the inventive concept, the elongated element 70 has been omitted in FIG. 10, however, typically the elongated element may be arranged in the through-hole 73 of the positioning element 70. As derivable from FIG. 10, the positioning element may facilitate a centre axis 70x of the elongated element is positioned at a predetermined position when the positioning device is arranged in the displacement groove 40. Preferably, when the positioning element is arranged in the displacement groove, an opening of the through-hole may be arranged adjacent an opening of the unlocking groove 60, 60", 60".

Preferably, when the positioning element is arranged in the displacement groove, an opening of the through-hole may be arranged adjacent the second portion 32 of the locking tongue 30.

Preferably, when the positioning element is arranged in the displacement groove, at least a portion of the through-hole may be aligned with the unlocking groove.

Preferably, when the positioning element is arranged in the displacement groove, at least a portion of an opening of the through-hole may be arranged adjacent the guiding surface 37.

Preferably, when the positioning element is arranged in the displacement groove, at least a portion of the through-hole may be aligned with the guiding surface 37.

The positioning element may facilitate a centre axis 70x of the elongated element is positioned at a predetermined distance from the bottom surface 41 of the displacement groove, preferably also at a predetermined distance from the lower surface 43 of the displacement groove, optionally also at a predetermined distance from the upper surface 42 of the displacement groove 40, as illustrated in FIG. 10.

FIGS. 11A-11C schematically illustrate a method of disassembling assembled building panels, according to an embodiment of the inventive concept.

FIG. 11A shows two assembled building panels, such as the panel A, which may correspond to the second panel 2, and having second edge 22. FIG. 11A also shows the device of FIG. 9A arranged in a displacement groove of one of panel B, which may correspond to the first panel 1 and having a first edge 11.

FIG. 11B shows at least a portion of the elongated element 70 of the device 69 of FIG. 9A having been inserted in an unlocking groove 60, 60", 60" shown in FIG. 11A to thereby displace the locking tongue in the unlocking direction to obtain the unlocking position or state. Consequently, there may be provided horizontal play between the first portion 31 of the locking tongue 30 and the engagement portion 25 of the second edge 22 of the second panel, whereby the second panel 2 may be displaced vertically, hence whereby the second panel 2 is vertically unlocked from the first panel 1.

17

FIG. 11C shows a first and second building panel being disassembled by means of a vertical displacement of a second edge 22 of the second panel 2 relative a first edge 11 of a first panel 1.

When the word “about” or “essentially” or “substantially” is used in this specification in connection with a numerical value, it is intended that the associated numerical value include a tolerance of $\pm 10\%$ around the stated numerical value.

ITEMS

ITEM 1. A set of essentially identical panels 1, 2, such as building panels, provided with a mechanical locking system comprising:

a displaceable tongue 30 arranged in a displacement groove 40 having a first opening at a first edge 11 of a first panel 1, said tongue 30 being configured to be displaced in said displacement groove 40 along a displacement axis Ax to attain a locking state wherein a first portion 31 of the tongue 30 cooperates with a first tongue groove 20 having a second opening at a second edge 22 of an adjacent second panel 2, for vertical locking of the first and the second edge 11, 22; and

wherein a second portion 32 of said tongue 30 is configured to cooperate with said second edge 22 of said adjacent second panel 2 via an elongated element 70 for vertical unlocking of the first and the second edge 11, 22.

ITEM 2. Set of panels according to item 1, wherein a first engagement portion 34 of the second portion 32 is configured to engage with the elongated element 70 and delimits an unlocking groove 60 configured to receive the elongated element 70 such as to cause the tongue 30 to be displaced along the displacement axis Ax to attain an unlocking state for said vertical unlocking of the first 11 and the second edge 22.

ITEM 3. Set of panels according to item 1 or 2, wherein a second engagement portion 25 of the second edge 22 is configured to engage with the elongated element 70 and delimits the unlocking groove 60, preferably said second engagement portion 25 being provided externally of said first tongue groove 20, more preferably externally of and below said first tongue groove 20.

ITEM 4. Set of panels according to item 2 or 3, wherein said first engagement portion 34 and said second engagement portion 25 are planar and extend in parallel or substantially in parallel, preferably side by side and in parallel.

ITEM 5. Set of panels according to any one of items 2 to 4, wherein said unlocking groove 60 is configured to attain said unlocking state upon receiving an elongated element 70 having a constant cross-sectional width D_i in the longitudinal direction of said elongated element 70.

ITEM 6. Set of panels according to any one of the preceding items, wherein said displacement groove 40 comprises a bottom surface 41, an upper surface 42 and a lower surface 43, preferably said lower surface 43 being parallel to the upper surface 42 and/or parallel to the displacement axis Ax of the tongue 30.

ITEM 7. Set of panels according to item 6, wherein the second engagement portion 25 extends below a plane Px of the lower surface 43.

ITEM 8. Set of panels according to item 6 or 7, wherein a dimension Dy in the direction of a normal Ny of a plane Px of said lower surface 43, between the lower surface 43 and the first portion 31, corresponds at least to a maximum diameter D_i of the elongated element 70.

18

ITEM 9. Set of panels according to any one of items 6 to 8, wherein a dimension Dy in the direction of the normal Ny of a plane Px of said lower surface 43, between the lower surface 43 and the first portion 31, corresponds at least to a dimension Dx along the displacement axis Ax between the first engagement portion 34 and an outermost point 31a of the tongue 30.

ITEM 10. Set of panels according to any one of items 6 to 8, wherein a dimension Dy in the direction of the normal Ny of a plane Px of said lower surface 43, between the plane Px and the first portion 31 corresponds at least to a largest distance Dax along the displacement axis Ax between the second engagement portion 25 and an outermost point 31a of the tongue 30 in the locking state, preferably the largest distance of dimension Dax is measured between an outermost point of the second engagement portion 25 and an outermost point 31a of the tongue 30.

ITEM 10a. Set of panels according to any one of the preceding claims 9 to 10, wherein the dimension Dy is measured from a point on a lower surface of the first portion 31, said point being aligned, in the direction of the normal Ny, with an uppermost point of the elongated element 70.

ITEM 11. Set of panels according to any one of the preceding items 3 to 10a, wherein the second portion 32 and the diameter D_i of the elongated element 70 are configured to cooperate such that the tongue 30 is displaced along the displacement axis Ax at least to the extent that an outermost point of the second engagement portion 25 and an outermost point 31a of the first portion 31 do not overlap, preferably to the extent that there is provided a play dH in a horizontal plane H between the outermost point of the second engagement portion 25 and the outermost point 31a of the first portion 31.

ITEM 12. Set of panels according to any one of the preceding items, wherein said second portion 32 comprises a chamfered edge portion 36, said edge portion being an outer end portion in the longitudinal direction of the tongue, the chamfered edge portion 36 forming a guiding surface 37 configured to guide said elongated element 70 in the transverse direction T of said tongue 30, preferably a chamfered longitudinal edge portion 36.

ITEM 13. Set of panels according to any one of the preceding items, wherein said second edge 22 comprises a chamfered edge portion 36' for guiding said elongated element 70 towards said tongue 30.

ITEM 14. Set of panels according to any one of the preceding items, wherein said elongated element 70 has a rotationally symmetric cross-section in a transverse plane thereof, by an angle of less than 120 degrees, preferably less than 90 degrees, more preferably being circular.

ITEM 15. Set of panels according to any one of the preceding items, the elongated element 70 preferably configured to abut the second portion 32 and the second edge 22 simultaneously.

ITEM 16. A method for vertical unlocking a set of essentially identical panels 10, 20, such as building panels, provided with a mechanical locking system comprising:

a displaceable tongue 30 arranged in a displacement groove 40 having a first opening at a first edge 11 of a first panel 10, said tongue 30 configured to be displaced in said displacement groove 40 along a displacement axis Ax to attain a locking state wherein a first portion 31 of the tongue 30 is configured to cooperate with a first tongue groove 20 with a second opening at a second edge 22 of an adjacent second panel 2, for vertical locking of the first and the second edge 11, 22; and

19

wherein the method comprises: inserting an elongated element **70** in an unlocking groove **60** delimited by a first engagement portion **34** of said second portion of said tongue **30** and further delimited by a second engagement portion **25** of the second edge **22** of the second panel **2** disposed externally said tongue groove **20**, to thereby cause said tongue **30** to be displaced along the displacement axis **Ax** to attain an unlocking state for vertical unlocking of the first **11** and the second edge **22**.

ITEM 17. The method according to item 16, wherein the second portion **32** and the diameter **Di** of the elongated element **70** are configured to cooperate such that the tongue **30** is displaced along the displacement axis **Ax** at least to the extent that an outermost point of the second engagement portion **25** and an outermost point **31a** of the first portion **31** do not overlap.

ITEM 18. The method according to item 16 or 17, wherein the second portion **32** and the diameter **Di** of the elongated element **70** are configured to cooperate such that the tongue **30** is displaced along the displacement axis **Ax** at least to the extent that there is provided horizontal **H** play between an outermost point of the second engagement portion **25** and an outermost point **31a** of the first portion **31**.

ITEM 19. The method according to any one of items 16 to 18, further comprising:

providing a positioning element **71** to said elongated element **70**;

arranging said positioning element in said displacement groove **40**.

ITEM 20. A device **69** for unlocking a mechanical locking system of building panels **1, 2**, such as a set of building panels, assembled by means of said mechanical locking system, said mechanical locking system configured for horizontal and vertical locking of adjacent building panels,

said locking system comprising at a first edge **11** of a first building **1**, a displaceable locking tongue **30** configured to displace in a displacement groove **40** provided in said first edge of said first building panel, said locking tongue configured to displace between a locking position and an unlocking position,

wherein the locking position, the locking tongue **30** is configured in a protruding position wherein protruding from said displacement groove for cooperating with a tongue groove **20** provided in an adjacent edge **22** of a second adjacent building panel **2**;

wherein the unlocking position, the locking tongue is configured in a retracted position,

wherein said unlocking device comprises an elongated element **70** and a positioning element **71**,

wherein said positioning element is configured to be received in said displacement groove.

ITEM 21. Device according to item 20, wherein said positioning element is configured to be received in said displacement groove to thereby position a centre axis **70x** of said elongated element at a predetermined distance from a bottom surface **41** of the displacement groove.

ITEM 22. Device according to item 20, wherein said positioning element is configured to position a centre axis **70x** of the elongated element **70** in parallel with said first edge **11**, preferably parallel an upper surface **55** of the first panel.

ITEM 23. Device according to any one of items 20 to 22, wherein said positioning element is configured to be received in said displacement groove to thereby position a centre axis of said elongated element at a predetermined distance from a lower surface **43** of the displacement groove.

20

ITEM 24. Device according to any one of items 20 to 23, wherein the locking position, a first portion **31** of the locking tongue cooperates with the tongue groove **20** provided in the adjacent edge **22** of a second adjacent building panel **2**.

ITEM 25. Device according to any one of the preceding items 20 to 24, wherein the unlocking position, the first portion **31** of the locking tongue is configured such that there is provided horizontal **H** play between an outermost point **31a** of the first portion **31** and a lower portion **25**, such as vertically below said outer portion of said locking tongue, of the second edge **22** of the second adjacent panel **2**.

ITEM 26. Device according to any one of items 20 to 25, wherein said locking tongue comprises a second lower portion configured to cooperate with said elongated element for displacing the locking to said unlocking position.

ITEM 27. Device according to any one of items 20 to 26, wherein said second portion is configured to form an unlocking groove **60, 60", 60"** with an edge portion of said second edge of said second panel, when said first and second panel are configured in assembled position, said edge portion provided below and external said tongue groove.

ITEM 28. Device according to any of the preceding claims **20 to 27**, wherein said elongated element is rotational symmetric.

ITEM 29. Device according to any one of the preceding claims **20 to 28**, wherein said centre axis of said elongated element is positioned at least partially below said tongue groove/below said outer portion of said locking tongue.

ITEM 30. Device according to any one of the preceding items 20 to 29, wherein said device comprises a handle **72**.

ITEM 31. Device according to any one of the preceding items 20 to 30, wherein said positioning element is arranged on the elongated element, and preferably configured to be displaced along the elongated element.

ITEM 32. A device **69** for unlocking a mechanical locking system of building panels **1, 2** assembled by means of said mechanical locking system, said mechanical locking system being configured for horizontal and vertical locking of adjacent building panels,

said locking system comprising at a first edge **11** of a first building **1**, a displaceable locking tongue **30** configured to displace in a displacement groove **40** provided in said first edge of said first building panel, said locking tongue configured to displace between a locking position and an unlocking position,

wherein the locking position, the locking tongue **30** is configured in a protruding position wherein protruding from said displacement groove for cooperating with a tongue groove **20** provided in an adjacent edge **22** of a second adjacent building panel **2**;

wherein the unlocking position, the locking tongue is configured in a retracted position;

wherein said unlocking device comprises an elongated element **70** and a positioning element **71**,

wherein said positioning element is configured to be received in said displacement groove to thereby align a centre axis **70x** of said elongated element with an unlocking groove **60, 60", 60"** configured to receive said elongated element for configuring said locking tongue in said unlocking position in response to insertion of said elongated element in said unlocking groove.

ITEM 33. Device according to item 32, wherein said locking tongue comprises a second lower portion **32** configured to cooperate with said elongated element for displacing the locking to said unlocking position, and

21

wherein said second edge portion **25** of said second panel comprises provided below and external said tongue groove, and

wherein said unlocking groove **60**, **60''**, **60'''** is formed by said second portion **32** of said locking tongue and said edge portion **25** of said second edge **22**, when said first and second panel are configured in assembled position.

ITEM 34. Device according to any one of the preceding items 20 to 33, wherein said building panels comprises a set of building panels.

ITEM 35. A kit comprising the building panels according to any one of items 1 to 14 and a device according to any one of claims **20** to **34**.

The invention claimed is:

1. A set of essentially identical panels provided with a mechanical locking system comprising:

a displaceable tongue arranged in a displacement groove having a first opening at a first edge of a first panel, said tongue being configured to be displaced in said displacement groove along a displacement axis to attain a locking state wherein a first portion of the tongue cooperates with a first tongue groove having a second opening at a second edge of an adjacent second panel, for vertical locking of the first and the second edge; and wherein a second portion of said tongue is configured to cooperate with said second edge of said adjacent second panel via an elongated element for vertical unlocking of the first and the second edge,

wherein said elongated element has a circular cross-section in a transverse plane thereof.

2. The set of panels according to claim **1**, wherein a first engagement portion of the second portion is configured to engage with the elongated element and delimits an unlocking groove configured to receive the elongated element such as to cause the tongue to be displaced along the displacement axis to attain an unlocking state for said vertical unlocking of the first and the second edge.

3. The set of panels according to claim **2**, wherein said first engagement portion and said second engagement portion are planar and extend side by side or in parallel or substantially in parallel.

4. The set of panels according to claim **2**, wherein said unlocking groove is configured to attain said unlocking state upon receiving an elongated element having a constant cross-sectional width in the longitudinal direction of said elongated element.

5. The set of panels according to claim **1**, further comprising an unlocking groove arranged between a second engagement portion of the second edge of the second panel and the second portion of the tongue when the first and second panels are vertically locked,

wherein the second engagement portion of the second edge is configured to engage with the elongated element and delimits the unlocking groove, said second engagement portion being provided externally of said first tongue groove.

6. The set of panels according to claim **5**, wherein the second portion and the elongated element are configured to cooperate such that the tongue is displaced along the displacement axis at least to the extent that an outermost point of the second engagement portion and an outermost point of the first portion do not overlap.

7. The set of panels according to claim **1**, wherein said displacement groove comprises a bottom surface, an upper surface and a lower surface, said lower surface being parallel to the upper surface or parallel to the displacement axis of the tongue.

22

8. The set of panels according to claim **7**, wherein the second engagement portion extends below a plane of the lower surface.

9. The set of panels according to claim **7**, wherein a dimension in a direction of a normal of a plane of said lower surface, between the lower surface and the first portion, corresponds at least to a maximum diameter of the elongated element.

10. The set of panels according to claim **7**, wherein a dimension in a direction of the normal of a plane of said lower surface, between the lower surface and the first portion, corresponds at least to a dimension along the displacement axis between the first engagement portion and an outermost point of the tongue.

11. The set of panels according to claim **10**, wherein the dimension is measured from a point on a lower surface of the first portion, said point being aligned, in the direction of the normal, with an uppermost point of the elongated element.

12. The set of panels according to claim **7**, wherein a dimension in a direction of the normal of a plane of said lower surface, between the plane and the first portion corresponds at least to a largest distance of a dimension along the displacement axis between the second engagement portion and an outermost point of the tongue in the locking state, the largest distance of dimension is measured between an outermost point of the second engagement portion and an outermost point of the tongue.

13. The set of panels according to claim **1**, wherein said second portion comprises a chamfered edge portion, said edge portion being an outer end portion in the longitudinal direction of the tongue, the chamfered edge portion forming a guiding surface configured to guide said elongated element in the transverse direction of said tongue.

14. The set of panels according to claim **1**, wherein said second edge comprises a chamfered edge portion for guiding said elongated element towards said tongue.

15. A method for vertical unlocking a set of essentially identical panels, provided with a mechanical locking system comprising:

a displaceable tongue arranged in a displacement groove having a first opening at a first edge of a first panel, said tongue configured to be displaced in said displacement groove along a displacement axis to attain a locking state wherein a first portion of the tongue is configured to cooperate with a first tongue groove with a second opening at a second edge of an adjacent second panel, for vertical locking of the first and the second edge; and wherein the method comprises:

inserting an elongated element in an unlocking groove delimited by a first engagement portion of said second portion of said tongue and further delimited by a second engagement portion of the second edge of the second panel disposed externally said tongue groove, to thereby cause said tongue to be displaced along the displacement axis to attain an unlocking state for vertical unlocking of the first and the second edge, wherein the second portion and a diameter of the elongated element are configured to cooperate such that the tongue is displaced along the displacement axis at least to the extent that an outermost point of the second engagement portion and an outermost point of the first portion do not overlap,

the method further comprising:

providing a positioning element to said elongated element;
arranging said positioning element in said displacement groove.

23

16. A device for unlocking a mechanical locking system of building panels assembled by means of said mechanical locking system, said mechanical locking system configured for horizontal and vertical locking of adjacent building panels,

said locking system comprising at a first edge of a first building panel, a displaceable locking tongue configured to displace in a displacement groove provided in said first edge of said first building panel, said locking tongue configured to displace between a locking position and an unlocking position,

wherein the locking position, the locking tongue is configured in a protruding position wherein protruding from said displacement groove for cooperating with a tongue groove provided in an adjacent edge of a second adjacent building panel;

wherein the unlocking position, the locking tongue is configured in a retracted position;

wherein said unlocking device comprises an elongated element and a positioning element, and

wherein said positioning element is configured to be received in said displacement groove, wherein said positioning element is configured to be received in said displacement groove to thereby position a centre axis of said elongated element at a predetermined distance from a bottom surface of the displacement groove,

wherein said elongated element has a circular cross-section in a transverse plane thereof.

17. A set of essentially identical panels, provided with a mechanical locking system comprising:

24

a displaceable tongue arranged in a displacement groove having a first opening at a first edge of a first panel, said tongue being configured to be displaced in said displacement groove along a displacement axis to attain a locking state wherein a first portion of the tongue cooperates with a first tongue groove having a second opening at a second edge of an adjacent second panel, for vertical locking of the first and the second edge; and wherein a second portion of said tongue is configured to cooperate with said second edge of said adjacent second panel via an elongated element for vertical unlocking of the first and the second edge,

wherein an unlocking groove is arranged between a second engagement portion of the second edge of the second panel and the second portion of the tongue when the first and second panels are vertically locked, wherein the second engagement portion of the second edge is configured to engage with the elongated element and delimits the unlocking groove, said second engagement portion being provided externally of said first tongue groove,

wherein the second engagement portion of the second edge is configured to engage with the elongated element and delimits the unlocking groove, said second engagement portion being provided externally of said first tongue groove,

wherein said second engagement portion of the second edge being provided externally of and below said first tongue groove.

* * * * *