

US011754800B2

(12) **United States Patent**  
**Kim**

(10) **Patent No.:** **US 11,754,800 B2**  
(45) **Date of Patent:** **\*Sep. 12, 2023**

(54) **LENS DRIVING APPARATUS**

(71) Applicant: **LG INNOTEK CO., LTD.**, Seoul (KR)

(72) Inventor: **Ji Hoon Kim**, Gunpo-si (KR)

(73) Assignee: **LG INNOTEK CO., LTD.**, Seoul (KR)

(\*) Notice: Subject to any disclaimer, the term of this patent is extended or adjusted under 35 U.S.C. 154(b) by 163 days.

This patent is subject to a terminal disclaimer.

(21) Appl. No.: **17/203,203**

(22) Filed: **Mar. 16, 2021**

(65) **Prior Publication Data**

US 2021/0208358 A1 Jul. 8, 2021

**Related U.S. Application Data**

(63) Continuation of application No. 15/910,614, filed on Mar. 2, 2018, now Pat. No. 10,983,298, which is a (Continued)

(30) **Foreign Application Priority Data**

Nov. 23, 2006 (KR) ..... 10-2006-0116317

(51) **Int. Cl.**

**G02B 7/02** (2021.01)

**G11B 7/09** (2006.01)

(Continued)

(52) **U.S. Cl.**

CPC ..... **G02B 7/023** (2013.01); **G02B 7/08** (2013.01); **G02B 27/0006** (2013.01); **G03B 3/10** (2013.01);

(Continued)

(58) **Field of Classification Search**

CPC ..... G02B 7/023; G02B 27/0006; G03B 3/10; G11B 7/0933; G11B 7/0935; H02K 41/0356; H02K 33/18

See application file for complete search history.

(56) **References Cited**

U.S. PATENT DOCUMENTS

5,177,640 A 1/1993 Grassens  
6,856,469 B2 2/2005 Yoneyama et al.

(Continued)

FOREIGN PATENT DOCUMENTS

CN 1763623 A 4/2006  
CN 1831576 A 9/2006

(Continued)

OTHER PUBLICATIONS

Notice of Allowance dated Nov. 8, 2017 in U.S. Appl. No. 14/473,771.  
(Continued)

*Primary Examiner* — Alicia M Harrington

(74) *Attorney, Agent, or Firm* — Saliwanchik, Lloyd & Eisenschenk

(57) **ABSTRACT**

Disclosed is a lens driving apparatus. The lens driving apparatus includes a base, a yoke coupled to the base, having an upper surface formed with a hole, a closed side surface, and an opened bottom surface, a bobbin movably installed in an inner portion of the yoke, a lens module coupled to the bobbin to go in and out the hole according to movement of the bobbin, a magnet fixed to an inner portion of the yoke, a coil fixed to an outer portion of the bobbin while facing the magnets, and springs coupled to the bobbin to provide restoration force to the bobbin.

**20 Claims, 2 Drawing Sheets**

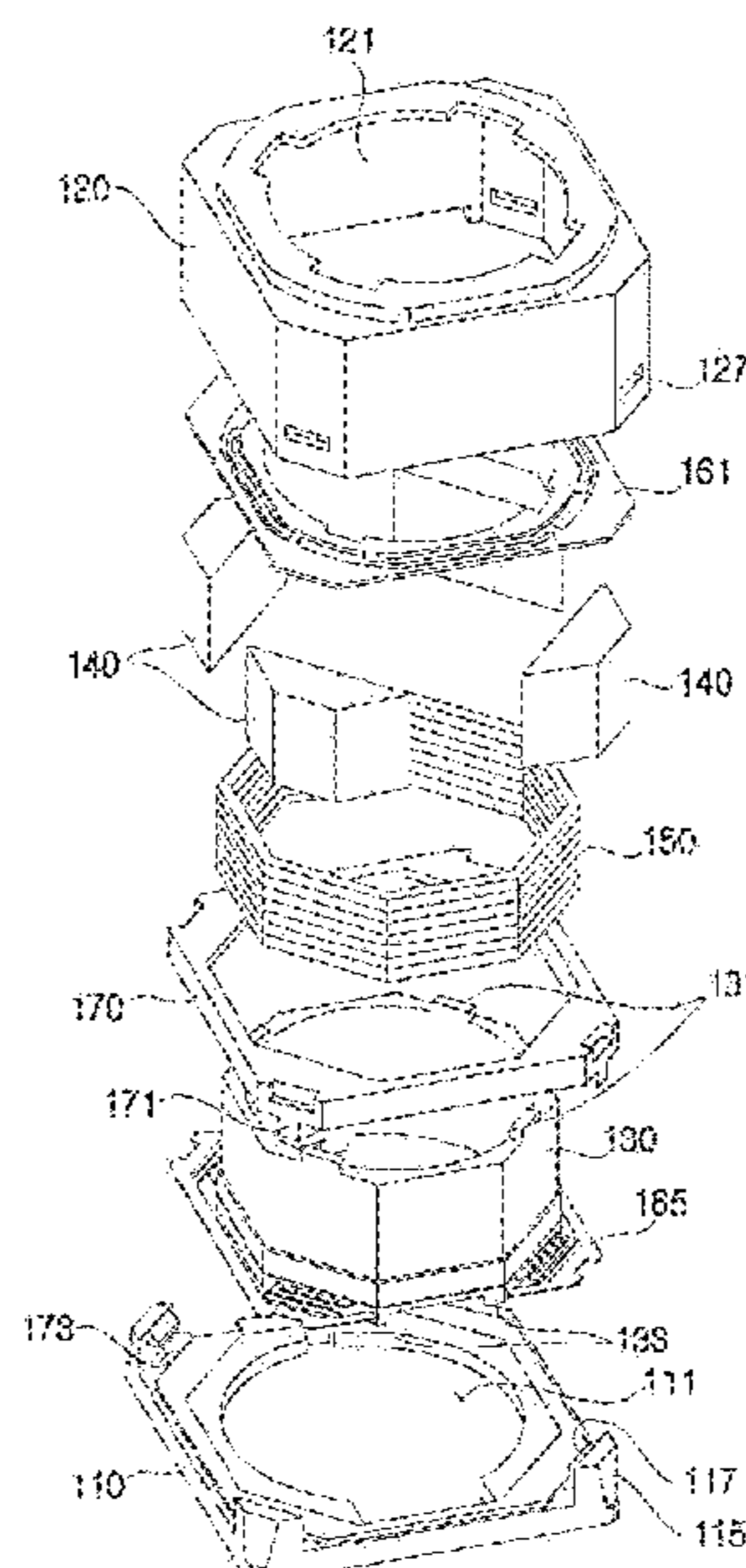

**Related U.S. Application Data**

continuation of application No. 13/873,978, filed on Apr. 30, 2013, now Pat. No. 9,939,606, which is a continuation of application No. 12/910,293, filed on Oct. 22, 2010, now Pat. No. 8,451,553, which is a continuation of application No. 12/516,146, filed as application No. PCT/KR2007/005901 on Nov. 22, 2007, now Pat. No. 7,885,023.

KR	10-2005-0093111	A	9/2005
KR	10-0548869	B1	1/2006
KR	10-2006-0023760	A	3/2006
KR	10-2006-0084130	A	7/2006
KR	10-2008-0046819	A	5/2008
TW	200525859	A	8/2005
TW	M285846	U	1/2006
TW	M290574	U	5/2006
TW	265668	B	11/2006

**OTHER PUBLICATIONS**

Office Action dated May 11, 2017 in U.S. Appl. No. 14/473,771.  
 Office Action dated Jan. 26, 2017 in U.S. Appl. No. 14/473,771.  
 Office Action dated Jul. 22, 2016 in U.S. Appl. No. 14/473,771.  
 European Search Report dated Dec. 16, 2014 in European Application No. 14183960.5.  
 First Office Action dated Mar. 21, 2012 in Chinese Application No. 201110151745.4, filed Nov. 22, 2007.  
 Office Action dated Apr. 18, 2014 in Korean Application No. 10-2013-0045730.  
 Office Action dated Apr. 20, 2012 in Korean Application No. 10-2010-0131070, filed Dec. 20, 2010.  
 Office Action dated Apr. 23, 2012 in Korean Application No. 10-2006-0116317, filed Nov. 23, 2006.  
 Office Action dated Dec. 29, 2014 in Korean Application No. 10-2014-0105248.  
 Office Action dated Jan. 26, 2017 in U.S. Appl. No. 14/437,771.  
 Office Action dated May 4, 2016 in Korean Application No. 10-2016-0023684.  
 Office Action dated Nov. 5, 2015 in Taiwan Application No. 103130234.  
 Office Action dated Oct. 8, 2012 in Korean Application No. 10-2010-0131070, filed Dec. 20, 2010.  
 Office Action dated Sep. 6, 2017 in Taiwanese Application No. 105136133, along with its English Translation.  
 Supplementary European Search Report dated Apr. 2, 2012 in European Application No. 07834206.0, filed Nov. 22, 2007.  
 European Search Report dated Jun. 29, 2018 in European Application No. 18162370.3.  
 Office Action dated Aug. 1, 2019 in U.S. Appl. No. 15/910,614.  
 Office Action dated Jan. 30, 2020 in U.S. Appl. No. 15/910,614.  
 Office Action dated Sep. 30, 2020 in U.S. Appl. No. 15/910,614.  
 Notice of Allowance dated Dec. 16, 2020 in U.S. Appl. No. 15/910,614.  
 Office Action dated Aug. 5, 2013 in U.S. Appl. No. 13/873,978.  
 Office Action dated Feb. 24, 2014 in U.S. Appl. No. 13/873,978.  
 Office Action dated Nov. 3, 2014 in U.S. Appl. No. 13/873,978.  
 Office Action dated Aug. 20, 2015 in U.S. Appl. No. 13/873,978.  
 Office Action dated Jul. 25, 2016 in U.S. Appl. No. 13/873,978.  
 Office Action dated Feb. 3, 2017 in U.S. Appl. No. 13/873,978.  
 Notice of Allowance dated Nov. 28, 2017 in U.S. Appl. No. 13/873,978.  
 Office Action dated Apr. 30, 2012 in U.S. Appl. No. 12/910,293.  
 Office Action dated Nov. 14, 2012 in U.S. Appl. No. 12/910,293.  
 Notice of Allowance dated Feb. 1, 2013 in U.S. Appl. No. 12/910,293.  
 Office Action dated Jun. 7, 2010 in U.S. Appl. No. 12/516,146.  
 Notice of Allowance dated Dec. 3, 2010 in U.S. Appl. No. 12/516,146.

(51) **Int. Cl.**

**H02K 41/035** (2006.01)  
**G02B 7/08** (2021.01)  
**G03B 3/10** (2021.01)  
**G02B 27/00** (2006.01)

(52) **U.S. Cl.**

CPC ..... **G11B 7/0933** (2013.01); **G11B 7/0935** (2013.01); **H02K 41/0356** (2013.01)

(56) **References Cited**

**U.S. PATENT DOCUMENTS**

7,298,562	B2	11/2007	Sue et al.	
7,394,603	B2	7/2008	Shiraki et al.	
7,400,068	B2	7/2008	Tseng	
7,649,703	B2	1/2010	Shiraki et al.	
7,751,134	B2 *	7/2010	Sata .....	G03B 13/36 359/813
7,916,412	B2	3/2011	Li et al.	
8,451,553	B2	5/2013	Kim	
9,939,606	B2	4/2018	Kim	
2002/0054547	A1	5/2002	Fujinoki et al.	
2006/0028320	A1	2/2006	Osaka	
2006/0034599	A1	2/2006	Osaka	
2006/0181632	A1	8/2006	Makii et al.	
2006/0203627	A1	9/2006	Osaka	
2007/0091199	A1	4/2007	Shiraki et al.	
2007/0110424	A1	5/2007	Iijima et al.	
2007/0133110	A1	6/2007	Huang	
2008/0055752	A1	3/2008	Ishizawa et al.	
2008/0117536	A1	5/2008	Higuchi	

**FOREIGN PATENT DOCUMENTS**

DE	20-2006-009115	U1	8/2006
EP	1698925	A1	9/2006
EP	1970741	A1	9/2008
JP	2002-352449	A	12/2002
JP	2003-005014	A	1/2003
JP	2003-149537	A	5/2003
JP	2005-173431	A	6/2005
JP	2005-234404	A	9/2005
JP	2006-047342	A	2/2006
JP	2006-074990		3/2006
JP	2006-259032	A	9/2006
KR	10-1999-0009117	A	2/1999
KR	20-0370323		12/2004
KR	10-2005-0029700	A	3/2005
KR	10-2005-0082413	A	8/2005

\* cited by examiner



[Fig. 1]

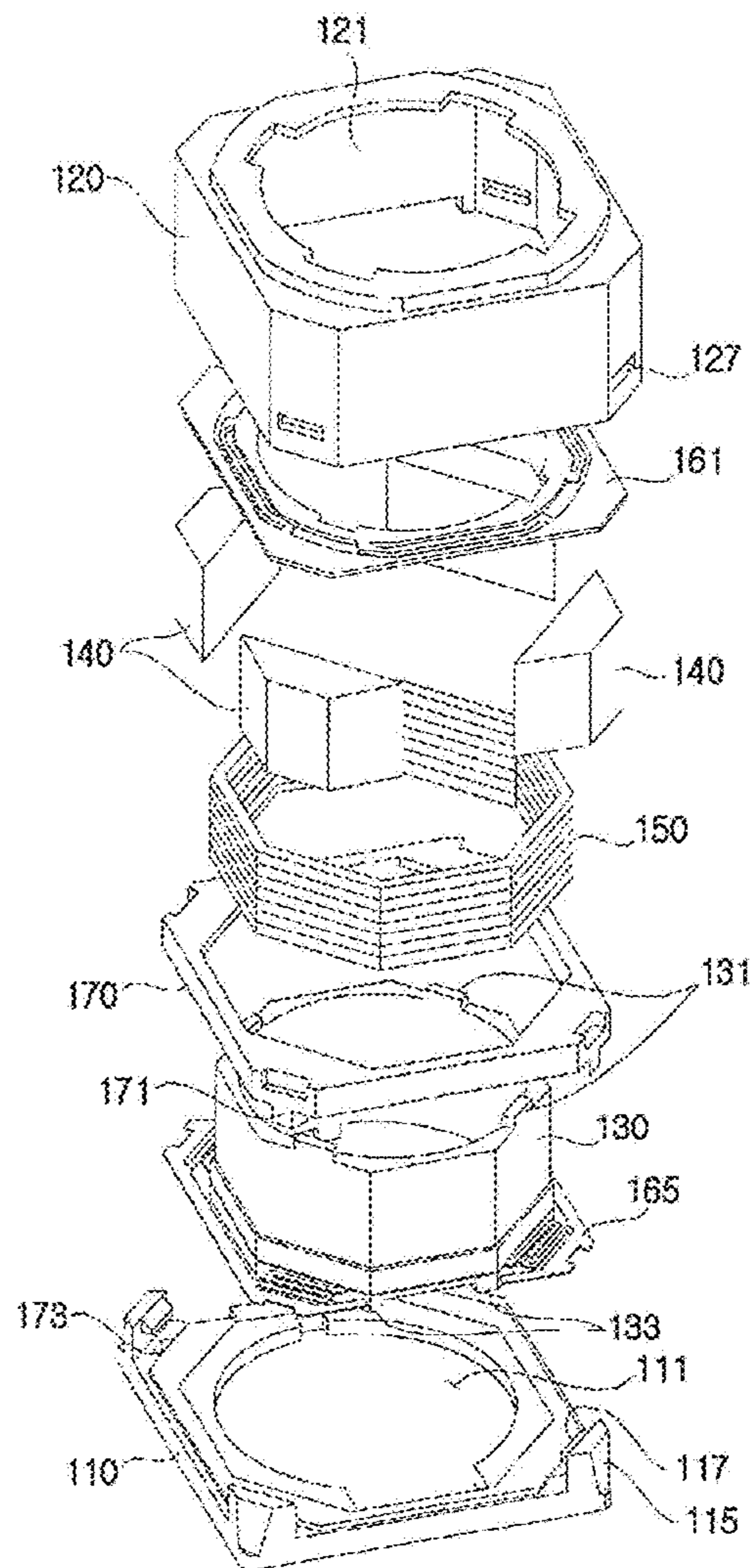

[Fig. 2]

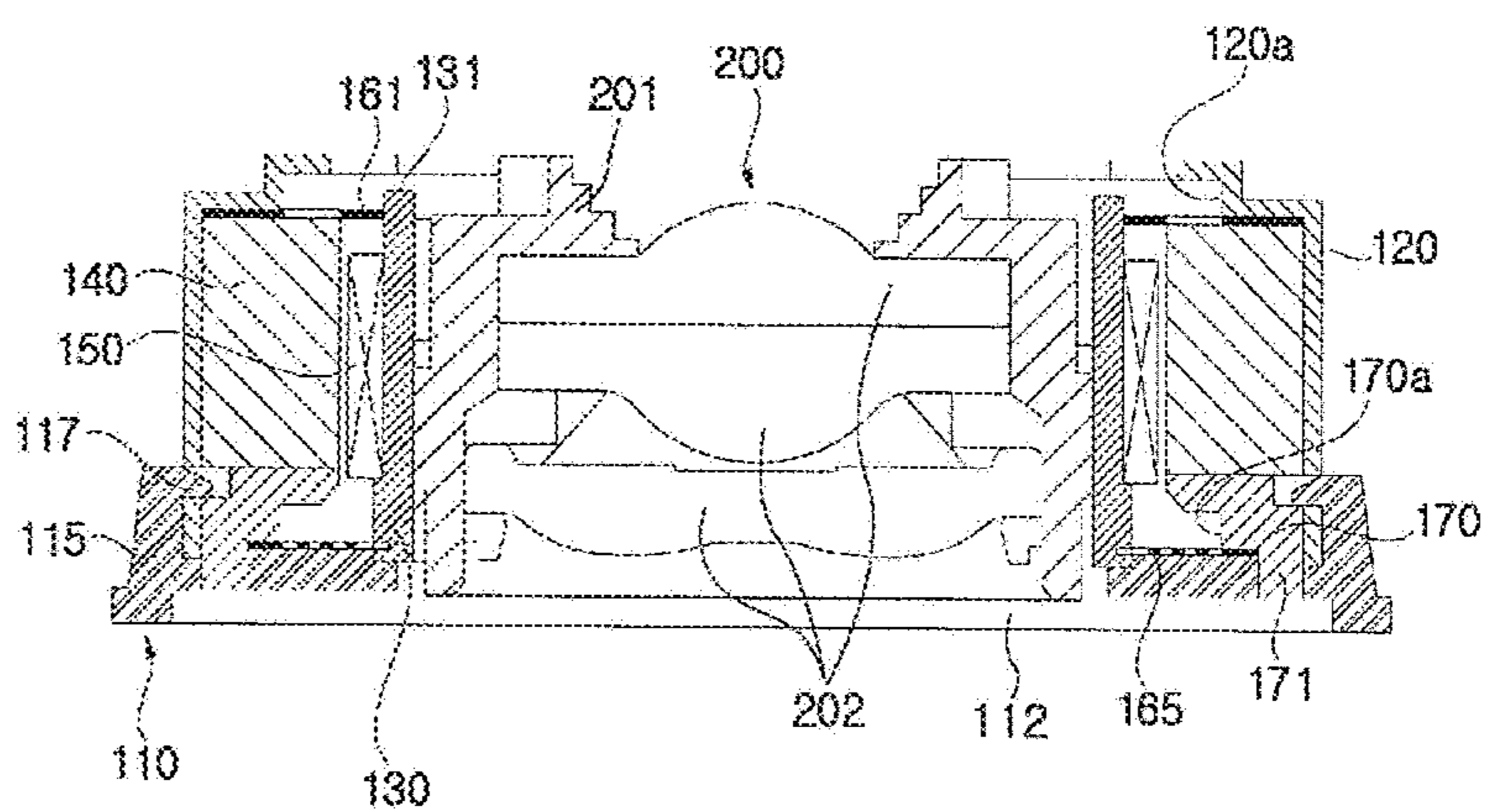

[Fig. 3]

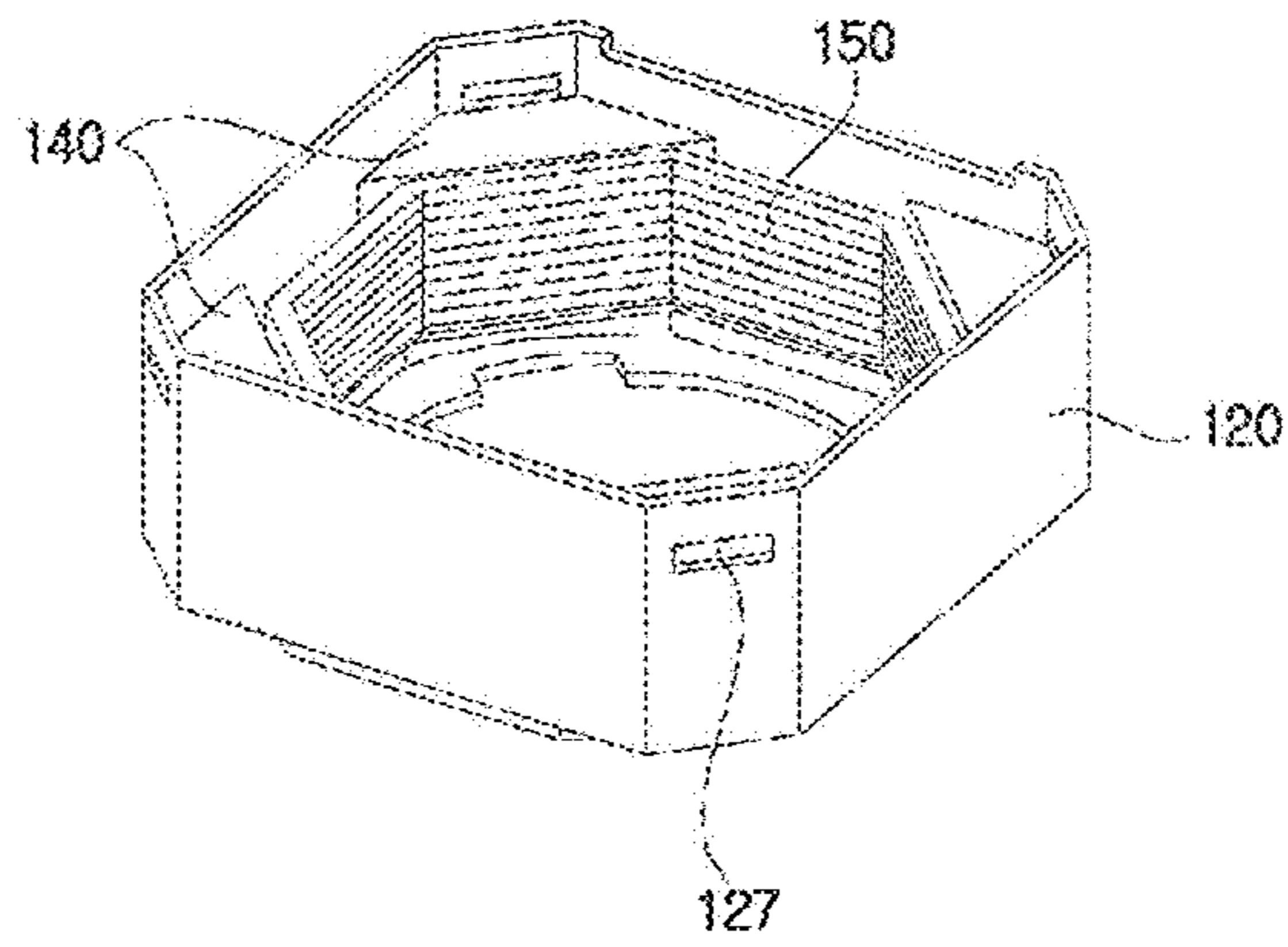

[Fig. 4]

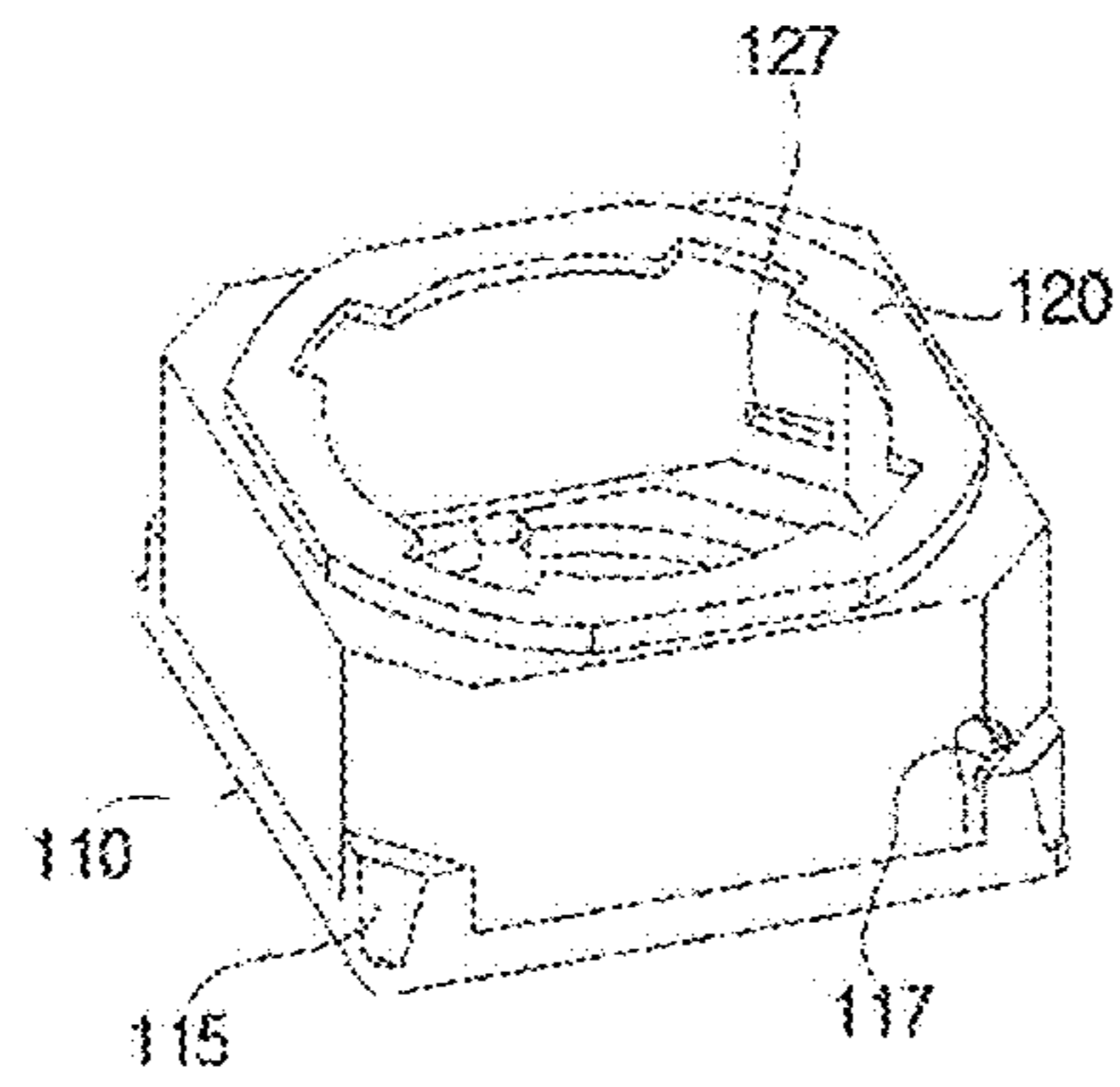



**1****LENS DRIVING APPARATUS****CROSS-REFERENCE TO RELATED APPLICATIONS**

This application is a continuation of U.S. application Ser. No. 15/910,614, filed Mar. 2, 2018, now U.S. Pat. No. 10,983,298, issued Apr. 20, 2021; which is a continuation of U.S. application Ser. No. 13/873,978, filed Apr. 30, 2013, now U.S. Pat. No. 9,939,606, issued Apr. 10, 2018; which is a continuation of U.S. application Ser. No. 12/910,293, filed Oct. 22, 2010, now U.S. Pat. No. 8,451,553, issued May 28, 2013; which is a continuation of U.S. application Ser. No. 12/516,146, filed May 22, 2009, now U.S. Pat. No. 7,885,023, issued Feb. 8, 2011; which is the U.S. national stage application of International Patent Application No. PCT/KR2007/005901, filed Nov. 22, 2007; which claims priority to Korean Patent Application No. 10-2006-0116317, filed Nov. 23, 2006, all of which are incorporated herein by reference in their entirety.

**TECHNICAL FIELD**

The present invention relates to a lens driving apparatus.

**BACKGROUND ART**

Recently, as electronic appliances have multi-functions, various electronic appliances having cameras therein, such as MP3 players, mobile communication terminals and PDAs, have been widely used.

As electronic appliances having cameras therein are manufactured in a small size, parts for providing camera functions must also be manufactured in a small size.

Further, since electronic appliances having cameras therein may be easily exposed to external environment or impact in terms of the characteristics of portable electronic appliances, external impurities may easily penetrate into the electronic appliances or the electronic appliances may be easily broken by the impact.

**Technical Problem**

The embodiment provides a lens driving apparatus which can be designed in a simple structure and manufactured in a small size. The embodiment provides a lens driving apparatus having high resistance against impact and inhibiting penetration of external impurities.

**Technical Solution**

A lens driving apparatus according to an embodiment comprising: a base; a yoke coupled to the base, having an upper surface formed with a hole, a closed side surface, and an opened bottom surface; a bobbin movably installed in an inner portion of the yoke; a lens module coupled to the bobbin to go in and out the hole according to movement of the bobbin; a magnet fixed to an inner portion of the yoke; a coil fixed to an outer portion of the bobbin while facing the magnets; and springs coupled to the bobbin to provide restoration force to the bobbin.

**Advantageous Effects**

According to the lens driving apparatus of the embodiment, a yoke is directly coupled to a base and parts are installed in a space formed in an inner portion of the base

**2**

and the yoke. Accordingly, since an additional case is not necessary, the number of parts is reduced, an assembly procedure is simplified, and thus the manufacturing cost can be saved. Further, according to the lens driving apparatus of the embodiment, the base is coupled to the yoke while maintaining a sealing status by locking holes of the base and locking protrusions of the yoke.

That is, any gap does not exist in the sides of the base and the yoke, a hole of the yoke is shielded by a lens module, and a through hole of the base is closely coupled to an electronic appliance, so that impurities can be inhibited from penetrating into the inner space formed by the base and the yoke. As a result, the parts are not damaged by the impurities. Furthermore, when a prism magnet is used, since the manufacturing cost is saved as compared with a case of using a ring-shaped magnet, the economical efficiency can be improved.

**BRIEF DESCRIPTION OF THE DRAWINGS**

FIG. 1 is an exploded perspective view showing a lens driving apparatus according to the embodiment;

FIG. 2 is a sectional view showing the lens driving apparatus in FIG. 1;

FIG. 3 is a perspective view showing a state in which a magnet and a coil are installed at the yoke in FIG. 1; and

FIG. 4 is a perspective view showing a coupling state of the yoke and the base in FIG. 1.

**MODE FOR THE INVENTION**

Hereinafter, a lens driving apparatus according to an embodiment will be described with reference to accompanying drawings. FIG. 1 is an exploded perspective view showing the lens driving apparatus according to the embodiment, FIG. 2 is a sectional view showing the lens driving apparatus in FIG. 1, and FIG. 3 is a perspective view showing a state in which a magnet and a coil are installed at the yoke in FIG. 1.

As shown in FIGS. 1 and 2, the lens driving apparatus according to the embodiment comprises a base **110** and a metal yoke **120** which are coupled to each other to form a predetermined space.

The base **110** has a disc shape or a polygonal plate shape and is formed at the central portion thereof with a through hole **111**. The bottom surface of the base **110** is coupled to an electronic appliance (not shown) and a circuit substrate **112** provided with an image sensor (not shown) is arranged in the through hole **111**.

The yoke **120** is coupled to the base **110** to serve as a case for protecting parts. The yoke **120** has an upper surface, at which a hole **121** allowing entrance of a lens module **200** is formed, an opened bottom surface making contact with the upper surface of the base **110**, and closed lateral side surfaces.

The side surfaces of the lens driving apparatus according to the embodiment are closed by the base **110** and the yoke **120**. Accordingly, since an additional case for protecting the lens driving apparatus is not necessary, the structure of the lens driving apparatus can be simplified. Further, since the side surfaces of the lens driving apparatus are closed, external impurities cannot penetrate into the inner side of the lens driving apparatus.

A ring-shaped bobbin **130** that goes in and out the hole **121** is movably installed at the inner side of the yoke **120**. The lens module **200** provided with a lens **202** and a support



201 for supporting the lens 202 is coupled to the inner peripheral surface of the bobbin 130.

The bobbin 130 includes an outer surface having a circular or a polygonal shape corresponding to the yoke 120, and an inner surface having a circular shape corresponding to the outer surface of the lens module 200. According to the embodiment, the bobbin 130 includes an outer surface having an octagonal shape.

Magnets 140 are fixed to the inner peripheral surface of the yoke 120, and a coil 150 is wound around the outer peripheral surface of the bobbin 130 while facing the magnets 140.

The magnet 140 has a circular or a polygonal shape corresponding to the yoke 120. As shown in FIGS. 1 and 3, when the yoke 120 is a polygonal case, a plurality of prism magnets 140 are prepared and three sides of each magnet 140 make contact with the inner peripheral surface of the yoke 120.

In the lens driving apparatus according to the embodiment, since the magnets 140 are installed at four edges of the yoke 120, respectively, an empty space between the yoke 120 and the coil 150 can be effectively utilized. Accordingly, the lens driving apparatus can be manufactured in a smaller size. Further, since the prism magnet 140 is inexpensive as compared with a ring-shaped magnet, the lens driving apparatus with a low price can be manufactured.

Since the coil 150 is wound around the outer peripheral surface of the bobbin 130, the coil 150 has a circular or a polygonal shape corresponding to the outer surface of the bobbin 130. If the coil 150 has a polygonal shape and the magnet 140 has a circular shape, the distance between the coil 150 and the magnet 140 becomes non-uniform.

Accordingly, when the coil 150 has a polygonal shape, the magnet 140 has a prism shape as shown in FIGS. 1 and 3.

As electric current is applied to the coil 150, the coil 150 moves upward according to the interaction of the electric field generated by the coil 150 and the magnetic field generated by the magnet 140, and thus the bobbin 130 moves upward. Accordingly, the lens module 200 coupled to the bobbin 130 also moves upward.

In addition, if the electric current is not applied to the coil 150, the bobbin 130 moves downward. To this end, upper and lower leaf springs 161 and 165 having a coil structure are installed at the upper and lower portions of the bobbin 130 in order to provide restoration force for returning the bobbin 130 to the initial state.

At this time, the outer portion of the upper spring 161 is inserted between the yoke 120 and the upper surface of the magnet 140. Further, the inner portion of the upper spring 161 is inserted into first support protrusions 131 formed on the upper end surface of the bobbin 130. Accordingly, the upper spring 161 can be inhibited from being rotated and moved due to external impact.

The inner portion of the lower spring 165 is integrally formed with the bobbin 130 through injection molding, and the outer portion of the lower spring 165 is inserted between the bottom surface of a spacer 170 and the base 110. Further, second support protrusions 133 that make contact with the inner peripheral surface of the through hole 110 formed in the base 110 are formed on the lower end surface of the bobbin 130. The second support protrusions 133 guide and support the bobbin 130 such that the bobbin 130 can be coupled to another element at an exact position and exactly move upward and downward.

The spacer 170 is installed at the base 110 below the magnets 140 and the outer surface of the lower spring 165 is inserted between the lower surface of the spacer 170 and

the base 110. That is, the outer portion of the lower spring 165 is supported between the spacer 170 and the base 110, and the inner portion of the lower spring 165 is integrally formed with the bobbin 130, so that the lower spring 165 can be inhibited from being rotated and moved due to external impact.

Further, the spacer 170 has insertion protrusions 171 used for firm coupling and movement prevention of the spacer 170, and the base 110 has support holes 173 into which the insertion protrusions 171 are inserted.

The yoke 120 and the spacer 170 have step sections 120a and 170a, respectively, as shown in FIG. 2. The step sections 120a and 170a provide a space for movement of the middle parts of the upper and lower leaf springs 161 and 165.

Hereinafter, a coupling structure of the base 110 and the yoke 120 will be described with reference to FIGS. 1, 2 and 4.

FIG. 4 is a perspective view showing a coupling state of the yoke and the base in FIG. 1.

As shown in FIG. 4, the base 110 has a plurality of protrusion plates 115 protruding upward on the outer surface thereof, and locking protrusions 117 are formed at the protrusion plates 115, respectively. Further, the yoke 120 has locking holes 127 at the sides thereof, into which the locking protrusions 117 are inserted.

The base 110 is closely coupled to the yoke 120 by using the locking protrusions 117 and the locking holes 127.

Although embodiments have been described with reference to a number of illustrative embodiments thereof, it should be understood that numerous other modifications and embodiments can be devised by those skilled in the art that will fall within the spirit and scope of the principles of this disclosure.

#### INDUSTRIAL APPLICABILITY

The lens driving apparatus according to the embodiment can be manufactured in a small size, can inhibit external impurities from penetrating into the inner portion of the lens driving apparatus, and is not broken due to external impact.

Further, the lens driving apparatus according to the embodiment can be applied to both cameras and various electronic appliances provided with the cameras.

The invention claimed is:

1. A lens driving apparatus comprising:

- a base;
  - a metal case configured to serve as both a yoke and an outer case, the metal case being coupled to the base;
  - a bobbin disposed in the metal yoke;
  - a coil disposed on an outer portion of the bobbin;
  - four magnets facing the coil and disposed between the coil and the metal case; and
  - upper and lower springs disposed in the metal case and coupled to the bobbin,
- wherein the four magnets are disposed on four corners of the base, respectively,
- wherein each of the four magnets has a flat side surface facing the coil,
- wherein four regions of the outer portion of the bobbin have respective four flat surfaces, and
- wherein portions of the coil facing the four magnets are disposed on the four flat surfaces of the outer portion of the bobbin, respectively.

2. The lens driving apparatus as claimed in claim 1, wherein the upper spring is coupled to an upper portion of the bobbin and the lower spring is coupled to a lower portion of the bobbin,



5

wherein the upper spring has a first side coupled to the metal case, a second side coupled to the upper portion of the bobbin, and a middle part connecting the first side and the second side, and

wherein the first side of the upper spring is disposed between the metal case and at least one of the four magnets.

3. The lens driving apparatus as claimed in claim 2, wherein the metal case includes an upper surface and a side surface, and

wherein the middle part of the upper spring is spaced apart downwards from the upper surface of the metal case.

4. The lens driving apparatus as claimed in claim 3, wherein the side surface of the metal case is closed, and wherein the side surface of the metal case extends from the upper surface of the metal case towards the base.

5. The lens driving apparatus as claimed in claim 2, wherein the metal case comprises a step section to provide a space for movement of the middle part of the upper spring.

6. The lens driving apparatus as claimed in claim 2, wherein the second side of the upper spring is inserted into first support protrusions formed at the upper portion of the bobbin.

7. The lens driving apparatus as claimed in claim 1, wherein each of the four magnets has at least one flat side surface facing the metal case.

8. The lens driving apparatus as claimed in claim 7, wherein the coil is wound in an octagonal shape including four planar surfaces facing the four magnets, respectively.

9. The lens driving apparatus as claimed in claim 7, wherein three flat side surfaces of each of the four magnets face the metal case.

10. The lens driving apparatus as claimed in claim 1, wherein the base has locking protrusions and the metal case has locking holes into which the locking protrusions are inserted.

11. The lens driving apparatus as claimed in claim 1, wherein a spacer is installed below the four magnets and coupled to the base.

6

12. The lens driving apparatus as claimed in claim 11, wherein the spacer comprises insertion protrusions and the base comprises support holes into which the insertion protrusions are inserted.

13. The lens driving apparatus as claimed in claim 1, wherein second support protrusions are formed at a lower portion of the bobbin to make contact with an inner peripheral surface of a through hole formed in the base.

14. The lens driving apparatus as claimed in claim 1, wherein the coil has a shape corresponding to the bobbin.

15. A camera comprising:

the lens driving apparatus of claim 1; and

a lens coupled to the bobbin of the lens driving apparatus.

16. The camera as claimed in claim 15, wherein the upper spring is coupled to an upper portion of the bobbin and the lower spring is coupled to a lower portion of the bobbin,

wherein the upper spring has a first side coupled to the metal case, a second side coupled to the upper portion of the bobbin, and a middle part connecting the first side and the second side, and

wherein the first side of the upper spring is disposed between the metal case and at least one of the four magnets.

17. The camera as claimed in claim 16, wherein the metal case includes an upper surface and a side surface, and wherein the middle part of the upper spring is spaced apart downwards from the upper surface of the metal case.

18. The camera as claimed in claim 17, wherein the side surface of the metal case is closed, and

wherein the side surface of the metal case extends from the upper surface of the metal case towards the base.

19. The camera as claimed in claim 16, wherein the metal case comprises a step section to provide a space for movement of the middle part of the upper spring.

20. An electronic appliance comprising the camera according to claim 15.

\* \* \* \* \*