

US011730622B2

(12) **United States Patent**
Hansen et al.

(10) **Patent No.:** **US 11,730,622 B2**
(45) **Date of Patent:** ***Aug. 22, 2023**

(54) **MEDICAL APPLIANCE WITH LAYERED
BASE PLATE AND/OR SENSOR ASSEMBLY
PART AND RELATED METHODS**

(52) **U.S. Cl.**
CPC *A61F 5/4404* (2013.01); *A61F 5/44*
(2013.01); *A61F 5/443* (2013.01); *A61F 5/445*
(2013.01); *G01M 3/40* (2013.01); *H01R 33/74*
(2013.01)

(71) Applicant: **Coloplast A/S, Humlebaek (DK)**

(58) **Field of Classification Search**
CPC *G01M 3/40*; *A61F 5/445*; *A61F 5/443*;
A61F 13/02; *A61F 13/42*; *A61F 13/0246*;
(Continued)

(72) Inventors: **Jais Ask Hansen**, Jaegerspris (DK);
Lars Erup Larsen, Maaloev (DK);
Niels Hvid, Vedbaek (DK); **Klaus
Thoegersen**, Charlottenlund (DK)

(56) **References Cited**

(73) Assignee: **Coloplast A/S, Humlebaek (DK)**

U.S. PATENT DOCUMENTS

(*) Notice: Subject to any disclaimer, the term of this
patent is extended or adjusted under 35
U.S.C. 154(b) by 0 days.

2,054,535 A 9/1936 Diack
2,327,514 A 8/1943 Fenwick
(Continued)

This patent is subject to a terminal dis-
claimer.

FOREIGN PATENT DOCUMENTS

(21) Appl. No.: **16/955,046**

CN 203786580 U 8/2014
CN 104902399 A 9/2015
(Continued)

(22) PCT Filed: **Dec. 20, 2018**

Primary Examiner — Catharine L Anderson

(86) PCT No.: **PCT/DK2018/050392**

Assistant Examiner — Linnae E. Raymond

§ 371 (c)(1),

(2) Date: **Jun. 18, 2020**

(74) *Attorney, Agent, or Firm* — Coloplast Corp.,
Coloplast A/S; Nick Baumann

(87) PCT Pub. No.: **WO2019/120436**

PCT Pub. Date: **Jun. 27, 2019**

(57) **ABSTRACT**

(65) **Prior Publication Data**

US 2020/0375782 A1 Dec. 3, 2020

Embodiments disclosed herein relate to a base plate and/or a sensor assembly part of an ostomy appliance. In embodiments, the base plate and/or the sensor assembly part comprises a first adhesive layer, a masking element, and a plurality of electrodes. The first adhesive layer includes a stomal opening with a center point and a proximal surface configured to be attached to a skin surface of a user. The masking element is arranged on a distal surface of the first adhesive layer, and is more insulative than the first adhesive layer. Further, the plurality of electrodes are arranged on a distal side of the first adhesive layer. Each electrode includes a sensing part and a conductor part and the masking element is arranged between the conductor parts and the first adhesive layer.

(30) **Foreign Application Priority Data**

Dec. 22, 2017 (DK) PA 2017 70993

(51) **Int. Cl.**

A61F 5/44 (2006.01)

G01M 3/40 (2006.01)

(Continued)

20 Claims, 9 Drawing Sheets

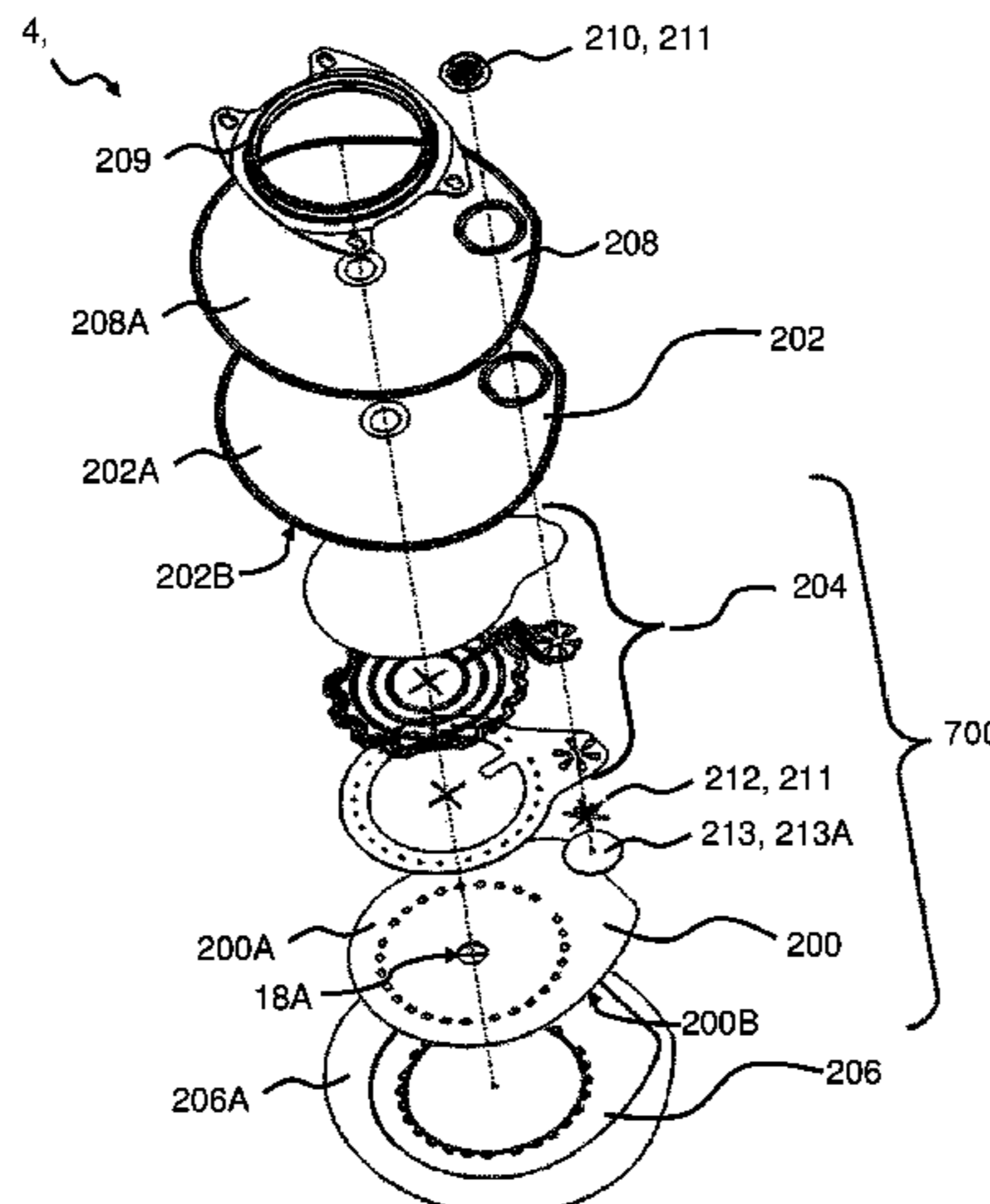

(51)	Int. Cl.		7,341,578 B2	3/2008	von Bulow et al.
	<i>A61F 5/443</i>	(2006.01)	7,347,844 B2	3/2008	Cline et al.
	<i>A61F 5/445</i>	(2006.01)	7,367,965 B2	5/2008	Poulsen et al.
	<i>H01R 33/74</i>	(2006.01)	7,422,578 B2	9/2008	Shan et al.
(58)	Field of Classification Search		7,559,922 B2	7/2009	Botten
	CPC	A61F 13/00051; A61F 5/44; A61F	7,625,362 B2	12/2009	Boehringer et al.
		5/4404-4408; A61F 2013/421-429; A61B	7,641,612 B1	1/2010	McCall
		5/746	7,670,289 B1	3/2010	McCall
	See application file for complete search history.		7,943,812 B2	5/2011	Stroebeck et al.
			7,981,098 B2	7/2011	Boehringer et al.
			8,061,360 B2	11/2011	Locke et al.
			8,277,427 B2	10/2012	Edwardsen et al.
(56)	References Cited		8,319,003 B2	11/2012	Olsen et al.
	U.S. PATENT DOCUMENTS		8,398,575 B1	3/2013	McCall
	2,542,233 A	2/1951 Carroll	8,398,603 B2	3/2013	Thirstrup et al.
	2,544,579 A	3/1951 Ardner	8,399,732 B2	3/2013	Oelund et al.
	3,214,502 A	10/1965 Schaar	8,409,158 B2	4/2013	Edwardsen et al.
	3,832,510 A	8/1974 Pfau et al.	8,449,471 B2	5/2013	Tran
	3,915,171 A	10/1975 Shermeta	8,474,338 B2	7/2013	Gelman et al.
	3,941,133 A	3/1976 Chen	8,500,718 B2	8/2013	Locke et al.
	4,231,369 A	11/1980 Sorensen et al.	8,632,492 B2	1/2014	DeLegge
	4,372,308 A	2/1983 Steer et al.	8,680,991 B2	3/2014	Tran
	4,449,970 A	5/1984 Bevan et al.	8,684,982 B2	4/2014	Nguyen-DeMary et al.
	4,668,227 A	5/1987 Kay	8,740,865 B2	6/2014	Krystek et al.
	4,754,264 A	6/1988 Okada et al.	8,795,257 B2	8/2014	Coulthard et al.
	4,775,374 A	10/1988 Cilento et al.	D712,545 S	9/2014	Igwebuike et al.
	4,834,731 A	5/1989 Nowak et al.	8,821,464 B2	9/2014	Hanuka et al.
	4,973,323 A	11/1990 Kaczmarek et al.	8,975,465 B2	3/2015	Hong et al.
	4,982,742 A	1/1991 Claude	8,979,813 B2	3/2015	Uveborn
	5,013,307 A	5/1991 Broida	9,046,085 B2	6/2015	Schoess et al.
	5,016,645 A	5/1991 Williams et al.	9,066,812 B2	6/2015	Edwardsen et al.
	5,051,259 A	9/1991 Olsen et al.	9,216,104 B2	12/2015	Thirstrup et al.
	5,074,851 A	12/1991 Plass et al.	9,308,332 B2	4/2016	Heppe
	5,111,812 A	5/1992 Swanson et al.	9,322,797 B1	4/2016	Lastinger et al.
	5,167,650 A	12/1992 Johnsen et al.	9,629,779 B2	4/2017	Grum-Schwensen et al.
	5,197,895 A	3/1993 Stupecky	9,629,964 B2	4/2017	Wuepper
	5,237,995 A	8/1993 Cano	9,693,908 B2	7/2017	Eriksson et al.
	5,318,543 A	6/1994 Ross et al.	9,770,359 B2	9/2017	Edwardsen et al.
	5,358,488 A	10/1994 Suriyapa	9,788,991 B2	10/2017	Bird
	5,486,158 A	1/1996 Samuelsen	9,867,934 B2	1/2018	Heppe
	5,570,082 A	10/1996 Mahgerefteh et al.	9,928,341 B2	3/2018	Angelides
	5,593,397 A	1/1997 La Gro	10,016,298 B2	7/2018	Thirstrup et al.
	5,672,163 A	9/1997 Ferreira et al.	D826,740 S	8/2018	Stevens et al.
	5,677,221 A	10/1997 Tseng	10,500,084 B2	12/2019	Hansen et al.
	5,704,905 A	1/1998 Jensen et al.	10,531,977 B2	1/2020	Schoess et al.
	5,790,036 A	8/1998 Fisher et al.	10,646,370 B2	5/2020	Keleny et al.
	5,800,415 A	9/1998 Olsen	10,792,184 B2	10/2020	Hvid et al.
	5,816,252 A	10/1998 Faries, Jr. et al.	10,799,385 B2*	10/2020	Hansen A61F 5/443
	5,834,009 A	11/1998 Sawers et al.	10,849,781 B2	12/2020	Hansen et al.
	5,879,292 A	3/1999 Sternberg et al.	10,874,541 B2	12/2020	Seres et al.
	6,015,399 A	1/2000 Mraчна et al.	10,987,243 B2	4/2021	Thirstrup et al.
	6,025,725 A	2/2000 Gershenfeld et al.	11,096,818 B2	8/2021	Thirstrup et al.
	6,057,689 A	5/2000 Saadat	11,135,084 B2	10/2021	Seres et al.
	6,103,033 A	8/2000 Say et al.	11,406,525 B2	8/2022	Seres et al.
	6,135,986 A	10/2000 Leisner et al.	11,471,318 B2	10/2022	Hansen et al.
	6,165,005 A	12/2000 Mills et al.	11,491,042 B2	11/2022	Seres et al.
	6,171,289 B1*	1/2001 Millot A61F 5/443	11,534,323 B2	12/2022	Hansen et al.
		604/336	11,540,937 B2	1/2023	Hansen et al.
	6,206,864 B1	3/2001 Kavanagh et al.	11,547,595 B2	1/2023	Hansen et al.
	6,246,330 B1	6/2001 Nielsen	11,547,596 B2	1/2023	Hansen et al.
	6,297,422 B1	10/2001 Hansen et al.	11,559,423 B2	1/2023	Speiermann et al.
	6,407,308 B1	6/2002 Roe et al.	11,559,426 B2	1/2023	Sletten et al.
	6,433,244 B1	8/2002 Roe et al.	2002/0019615 A1	2/2002	Roe et al.
	6,482,491 B1	11/2002 Samuelsen et al.	2003/0132763 A1	7/2003	Ellenz
	6,485,476 B1	11/2002 Von Dyck et al.	2003/0169032 A1	9/2003	Minchole et al.
	6,520,943 B1	2/2003 Wagner	2004/0006320 A1	1/2004	Buglino et al.
	6,524,675 B1	2/2003 Mikami et al.	2004/0030305 A1	2/2004	Sakamoto
	6,659,989 B1	12/2003 Otto	2004/0036484 A1	2/2004	Tamai
	6,764,474 B2	7/2004 Nielsen et al.	2004/0049145 A1	3/2004	Flick
	7,049,478 B1	5/2006 Smith	2004/0068244 A1	4/2004	Salone et al.
	7,066,919 B1	6/2006 Sauerland et al.	2004/0078219 A1	4/2004	Kaylor et al.
	7,150,728 B2	12/2006 Hansen et al.	2004/0100376 A1	5/2004	Lye et al.
	7,166,091 B1	1/2007 Zeltner	2004/0106908 A1	6/2004	Leise, Jr. et al.
	7,199,501 B2	4/2007 Pei et al.	2004/0111072 A1	6/2004	McKissick
	7,214,217 B2	5/2007 Pedersen et al.	2004/0133175 A1	7/2004	Hagedorn-Olsen
	7,221,279 B2	5/2007 Nielsen	2004/0171999 A1	9/2004	Andersen et al.
	7,326,190 B2	2/2008 Botten	2004/0193122 A1	9/2004	Cline et al.
			2004/0193123 A1	9/2004	Fenton
			2004/0216833 A1	11/2004	Fleming et al.

(56)

References Cited

U.S. PATENT DOCUMENTS

2005/0054997	A1	3/2005	Buglino et al.	2014/0276501	A1	9/2014	Cisco
2005/0065488	A1	3/2005	Elliott	2014/0288381	A1	9/2014	Faarbaek et al.
2005/0070863	A1	3/2005	Bulow et al.	2014/0303574	A1	10/2014	Knutson
2005/0085779	A1	4/2005	Poulsen et al.	2014/0323909	A1	10/2014	Kim
2005/0101841	A9	5/2005	Kaylor et al.	2014/0327433	A1	11/2014	Anway et al.
2005/0240163	A1	10/2005	Andersen	2014/0336493	A1	11/2014	Kulach et al.
2005/0261645	A1	11/2005	Conrad et al.	2015/0231802	A1	8/2015	Quan et al.
2006/0015081	A1	1/2006	Suzuki et al.	2015/0250639	A1	9/2015	Thirstrup et al.
2006/0025727	A1	2/2006	Boehringer et al.	2015/0257923	A1	9/2015	Thirstrup et al.
2006/0052752	A1	3/2006	McMichael	2015/0342777	A1	12/2015	Seres et al.
2006/0194324	A1	8/2006	Faries, Jr. et al.	2015/0351690	A1	12/2015	Toth et al.
2006/0271002	A1	11/2006	Botten	2015/0374896	A1	12/2015	Du et al.
2007/0010256	A1	1/2007	Klabunde et al.	2016/0015570	A1	1/2016	Heinecke et al.
2007/0035405	A1	2/2007	Wada et al.	2016/0084869	A1	3/2016	Yuen et al.
2007/0135782	A1	6/2007	Bager et al.	2016/0158056	A1	6/2016	Davis et al.
2007/0185464	A1	8/2007	Fattman et al.	2016/0158969	A1	6/2016	McLane et al.
2008/0038536	A1	2/2008	Strobech et al.	2016/0166438	A1	6/2016	Rovaniemi
2008/0071214	A1	3/2008	Locke et al.	2016/0218555	A1	7/2016	Slaby et al.
2008/0075934	A1	3/2008	Barlow, Jr. et al.	2016/0235581	A1	8/2016	Keleny et al.
2008/0091154	A1	4/2008	Botten	2016/0278990	A1	9/2016	Chen
2008/0096726	A1	4/2008	Riley et al.	2016/0284084	A1	9/2016	Gurcan et al.
2008/0097360	A1	4/2008	Andersen et al.	2016/0305776	A1	10/2016	Mårtensson et al.
2008/0140057	A1	6/2008	Wood et al.	2016/0310140	A1	10/2016	Belson et al.
2008/0234641	A1	9/2008	Locke et al.	2016/0310329	A1	10/2016	Patel et al.
2008/0275327	A1	11/2008	Faarbaek et al.	2016/0317728	A1	11/2016	Lewis et al.
2008/0278337	A1	11/2008	Huang et al.	2016/0361015	A1	12/2016	Wang et al.
2008/0300559	A1	12/2008	Gustafson et al.	2017/0042614	A1	2/2017	Salahieh et al.
2008/0306459	A1	12/2008	Albrechtsen	2017/0050004	A1	2/2017	Tilson et al.
2009/0012501	A1	1/2009	Boehringer et al.	2017/0055896	A1	3/2017	Al-Ali et al.
2009/0118600	A1	5/2009	Ortiz et al.	2017/0079530	A1	3/2017	DiMaio et al.
2009/0118687	A1	5/2009	Kristensen et al.	2017/0079576	A1	3/2017	Stroebech et al.
2009/0167286	A1	7/2009	Naylor et al.	2017/0140103	A1	5/2017	Angelides
2009/0173935	A1	7/2009	Cho et al.	2017/0156920	A1	6/2017	Hunt et al.
2009/0216169	A1	8/2009	Hansen et al.	2017/0262986	A1	9/2017	Xiong et al.
2009/0227969	A1	9/2009	Jaeb et al.	2017/0319073	A1	11/2017	DiMaio et al.
2009/0247970	A1	10/2009	Keleny et al.	2017/0340474	A1	11/2017	Thirstrup et al.
2010/0010460	A1	1/2010	Butler	2017/0348137	A1	12/2017	Hvid et al.
2010/0030167	A1*	2/2010	Thirstrup A61F 5/4404 340/657	2017/0360592	A1	12/2017	Carrubba
2010/0036206	A1	2/2010	Lorio	2018/0021164	A1	1/2018	Fenton
2010/0072271	A1	3/2010	Thorstensson	2018/0021165	A1	1/2018	Fenton
2010/0076275	A1	3/2010	Chu et al.	2018/0049667	A1	2/2018	Heppe
2011/0034890	A1	2/2011	Stroebech et al.	2018/0055359	A1	3/2018	Shamim et al.
2011/0077497	A1	3/2011	Oster et al.	2018/0078163	A1	3/2018	Welch
2011/0130642	A1	6/2011	Jaeb et al.	2018/0109852	A1	4/2018	Mandapaka et al.
2012/0013130	A1	1/2012	Jung	2018/0171183	A1	6/2018	Sakurai et al.
2012/0143154	A1	6/2012	Edwardsen et al.	2018/0177626	A1	6/2018	Israelson
2012/0143155	A1	6/2012	Edwardsen et al.	2018/0250156	A1	9/2018	Lam
2012/0253224	A1	10/2012	Mir et al.	2018/0344533	A1	12/2018	Rovaniemi
2012/0258302	A1	10/2012	Hunt et al.	2019/0099552	A1	4/2019	Zhang et al.
2012/0259230	A1	10/2012	Riley	2019/0133810	A1	5/2019	Seres et al.
2012/0283678	A1	11/2012	Nguyen-Demary et al.	2019/0133811	A1	5/2019	Seres et al.
2013/0018231	A1	1/2013	Hong et al.	2019/0133812	A1*	5/2019	Seres A61B 5/14539
2013/0030167	A1	1/2013	Wang et al.	2019/0142623	A1	5/2019	Schoess et al.
2013/0030397	A1	1/2013	Sabeti	2019/0175386	A1	6/2019	Monty
2013/0060213	A1	3/2013	Hanuka et al.	2019/0192066	A1	6/2019	Schoess et al.
2013/0066285	A1	3/2013	Locke et al.	2019/0192332	A1	6/2019	Hansen et al.
2013/0072886	A1	3/2013	Schertiger et al.	2019/0192333	A1	6/2019	Hansen et al.
2013/0102979	A1	4/2013	Coulthard et al.	2019/0192334	A1	6/2019	Hansen et al.
2013/0138065	A1	5/2013	Buus	2019/0240059	A1	8/2019	Seres et al.
2013/0150769	A1	6/2013	Heppe	2019/0247050	A1	8/2019	Goldsmith
2013/0165862	A1	6/2013	Griffith et al.	2019/0374163	A1	12/2019	Faarbaek et al.
2013/0192604	A1	8/2013	Persson et al.	2019/0374372	A1	12/2019	Seres et al.
2013/0231620	A1	9/2013	Thirstrup et al.	2020/0100931	A1	4/2020	Schoess et al.
2013/0261575	A1	10/2013	Kiyoshi	2020/0188161	A1	6/2020	Seres et al.
2013/0267790	A1	10/2013	Pfuetzner et al.	2020/0246174	A1	8/2020	Hansen et al.
2013/0303867	A1	11/2013	Elfstrom et al.	2020/0246175	A1	8/2020	Hansen et al.
2013/0324952	A1	12/2013	Krystek et al.	2020/0246176	A1	8/2020	Hansen et al.
2013/0324955	A1	12/2013	Wong et al.	2020/0246177	A1	8/2020	Hansen et al.
2014/0051946	A1	2/2014	Arne et al.	2020/0276063	A1	9/2020	Munoz Herencia
2014/0200538	A1*	7/2014	Euliano A61F 13/42 604/361	2020/0306074	A1	10/2020	Speiermann et al.
2014/0236111	A1	8/2014	Casado et al.	2020/0330258	A1	10/2020	Hansen et al.
2014/0236335	A1	8/2014	Lewis et al.	2020/0330260	A1	10/2020	Hansen et al.
2014/0275854	A1	9/2014	Venkatraman et al.	2020/0337880	A1	10/2020	Hansen et al.
				2020/0337881	A1	10/2020	Hansen et al.
				2020/0337882	A1	10/2020	Hansen et al.
				2020/0337883	A1	10/2020	Hansen et al.
				2020/0375499	A1	12/2020	Hansen et al.
				2020/0375782	A1	12/2020	Hansen et al.
				2020/0375783	A1	12/2020	Hansen et al.

(56)

References Cited

U.S. PATENT DOCUMENTS

2020/0375784 A1 12/2020 Hansen et al.
 2020/0375785 A1 12/2020 Hansen et al.
 2020/0375786 A1 12/2020 Hansen et al.
 2020/0383637 A1 12/2020 Hansen et al.
 2020/0383818 A1 12/2020 Hansen et al.
 2020/0383819 A1 12/2020 Sletten et al.
 2020/0383820 A1 12/2020 Hansen et al.
 2020/0383821 A1 12/2020 Hansen et al.
 2020/0390587 A1 12/2020 Svanegaard et al.
 2020/0390588 A1 12/2020 Hansen et al.
 2020/0390589 A1 12/2020 Hansen et al.
 2020/0395120 A1 12/2020 Svanegaard et al.
 2020/0395610 A1 12/2020 Ono et al.
 2020/0405228 A1 12/2020 Svanegaard et al.
 2020/0405229 A1 12/2020 Svanegaard et al.
 2020/0405230 A1 12/2020 Svanegaard et al.
 2021/0000414 A1 1/2021 Svanegaard et al.
 2021/0000633 A1 1/2021 Hansen et al.
 2021/0000634 A1 1/2021 Svanegaard et al.
 2021/0000635 A1 1/2021 Hansen et al.
 2021/0000636 A1 1/2021 Hansen et al.
 2021/0007663 A1 1/2021 Svanegaard et al.
 2021/0007881 A1 1/2021 Svanegaard et al.
 2021/0015653 A1 1/2021 Hansen et al.
 2021/0015654 A1 1/2021 Hansen et al.
 2021/0022683 A1 1/2021 Faarbaek et al.
 2021/0038424 A1 2/2021 Svanegaard et al.
 2021/0059603 A1 3/2021 Svanegaard et al.
 2021/0085511 A1 3/2021 Hansen et al.
 2021/0085512 A1 3/2021 Hansen et al.
 2021/0100533 A1* 4/2021 Seres A61B 5/42
 2021/0128364 A1 5/2021 Cole et al.
 2021/0177642 A1 6/2021 Andersen et al.
 2021/0212855 A1 7/2021 Hansen et al.
 2021/0228194 A1 7/2021 Mayberg
 2021/0338471 A1 11/2021 Nolan et al.
 2021/0361464 A1 11/2021 Larsen et al.
 2021/0361465 A1 11/2021 Hansen et al.
 2021/0361466 A1 11/2021 Hansen et al.
 2021/0361467 A1 11/2021 Hansen et al.
 2021/0369197 A1 12/2021 Hansen et al.
 2021/0369488 A1 12/2021 Hansen et al.
 2021/0369489 A1 12/2021 Hansen et al.
 2021/0369490 A1 12/2021 Hansen et al.
 2022/0000652 A1* 1/2022 Thirstrup A61F 5/443
 2022/0031495 A1 2/2022 Seres et al.
 2022/0079802 A1 3/2022 Hansen
 2022/0079803 A1 3/2022 Windeballe et al.
 2022/0087851 A1 3/2022 Stroebach
 2022/0117771 A1 4/2022 Fearn et al.
 2022/0142807 A1 5/2022 Tofte
 2022/0192860 A1 6/2022 Hansen et al.
 2022/0241104 A1 8/2022 Knoedler
 2022/0241105 A1 8/2022 Hansen et al.
 2022/0265458 A1 8/2022 Carlsson et al.
 2022/0378602 A1 12/2022 Hansen et al.

FOREIGN PATENT DOCUMENTS

CN 104980878 A 10/2015
 CN 105588856 A 5/2016
 CN 206271160 U 6/2017
 CN 206450708 U 8/2017
 CN 107661167 A 2/2018
 DE 3437950 A1 4/1985
 DE 3836590 A1 5/1990
 DE 19953062 A1 5/2000
 DE 19900611 C1 7/2000
 DE 69722993 7/2003
 DE 102011014321 A1 9/2012
 DE 102011076219 A1 11/2012
 EP 0168967 A1 1/1986
 EP 0373782 B1 10/1994
 EP 0416397 B1 5/1995
 EP 0896211 A2 2/1999

EP 0800804 B1 6/2003
 EP 1188157 B1 12/2005
 EP 2108345 A1 10/2009
 EP 1275357 B1 3/2011
 EP 2000083 B1 8/2012
 EP 2601915 A1 6/2013
 EP 2738960 A1 6/2014
 EP 2489561 B1 8/2014
 EP 2654646 B1 7/2016
 EP 3226946 A1 10/2017
 EP 3213727 B1 12/2019
 EP 3064179 B1 9/2021
 GB 2219679 A 12/1989
 GB 2308306 B 9/1999
 GB 2343628 A1 5/2000
 GB 2465742 B 7/2012
 GB 2486968 B 2/2015
 GB 2542093 A 3/2017
 GB 2561193 B 9/2020
 JP H0474882 A 3/1992
 JP H06152077 A 5/1994
 JP H0910184 A 1/1997
 JP H11128352 A 5/1999
 JP 2000093448 A 4/2000
 JP 2001087299 A 4/2001
 JP 2002055074 A 2/2002
 JP 2002224093 A 8/2002
 JP 2005323981 A 11/2005
 JP 2007319561 A 12/2007
 JP 2009519751 A 5/2009
 JP 2014033745 A 2/2014
 JP 2014054368 A 3/2014
 JP 2014507182 A 3/2014
 KR 101056989 B1 8/2011
 KR 20120003987 A 1/2012
 KR 200485138 Y1 12/2017
 NL 1001019 C2 2/1997
 NL 1003904 C2 3/1998
 TW 201201783 A 1/2012
 WO 1994015562 A1 7/1994
 WO 1997010012 A1 3/1997
 WO 9933037 A1 7/1999
 WO 1999036017 A1 7/1999
 WO 0079497 A1 12/2000
 WO 2001013830 A1 3/2001
 WO 2001050996 A1 7/2001
 WO 2002052302 A2 7/2002
 WO 2002099765 A1 12/2002
 WO 2005038693 A1 4/2005
 WO 2005082271 A2 9/2005
 WO 2006008866 A1 1/2006
 WO 2006094513 A2 9/2006
 WO 2007000168 A1 1/2007
 WO 2007059774 A2 5/2007
 WO 2007070266 A1 6/2007
 WO 2007098762 A1 9/2007
 WO 2007133555 A2 11/2007
 WO 2008057884 A2 5/2008
 WO 2009006900 A1 1/2009
 WO 2009052496 A1 4/2009
 WO 2009107011 A1 9/2009
 WO 2009112912 A2 9/2009
 WO 2011003421 A1 1/2011
 WO 2011004165 A1 1/2011
 WO 2011061540 A1 5/2011
 WO 2011105701 A2 9/2011
 WO 2011123018 A1 10/2011
 WO 2011139499 A1 11/2011
 WO 2011161254 A2 12/2011
 WO 2012068386 A1 5/2012
 WO 2012076022 A2 6/2012
 WO 2012084987 A2 6/2012
 WO 2013013197 A1 1/2013
 WO 2014004207 A1 1/2014
 WO 2014086369 A1 6/2014
 WO 2015007284 A1 1/2015
 WO 2015014774 A1 2/2015
 WO 2015084462 A1 6/2015
 WO 2015094064 A1 6/2015

(56)

References Cited

FOREIGN PATENT DOCUMENTS

WO	2015187366	A1	12/2015	
WO	WO-2016089307	A1 *	6/2016 A61B 5/02
WO	2016132738	A1	8/2016	
WO	2016166731	A1	10/2016	
WO	2016192738	A1	12/2016	
WO	2017023794	A1	2/2017	
WO	2017062042	A1	4/2017	
WO	2017067558	A1	4/2017	
WO	2017067560	A1	4/2017	
WO	WO-2017067558	A1 *	4/2017 A61F 5/443
WO	2017074505	A1	5/2017	
WO	2017088153	A1	6/2017	
WO	2017136696	A1	8/2017	
WO	2017190752	A1	11/2017	
WO	2018028756	A1	2/2018	
WO	2019094635	A1	5/2019	
WO	2019120432	A1	6/2019	
WO	2019161859	A1	8/2019	
WO	2019161860	A1	8/2019	
WO	2019161863	A1	8/2019	
WO	2019174693	A1	9/2019	
WO	2019174695	A1	9/2019	
WO	2019213623	A1	11/2019	
WO	2020035121	A1	2/2020	

* cited by examiner

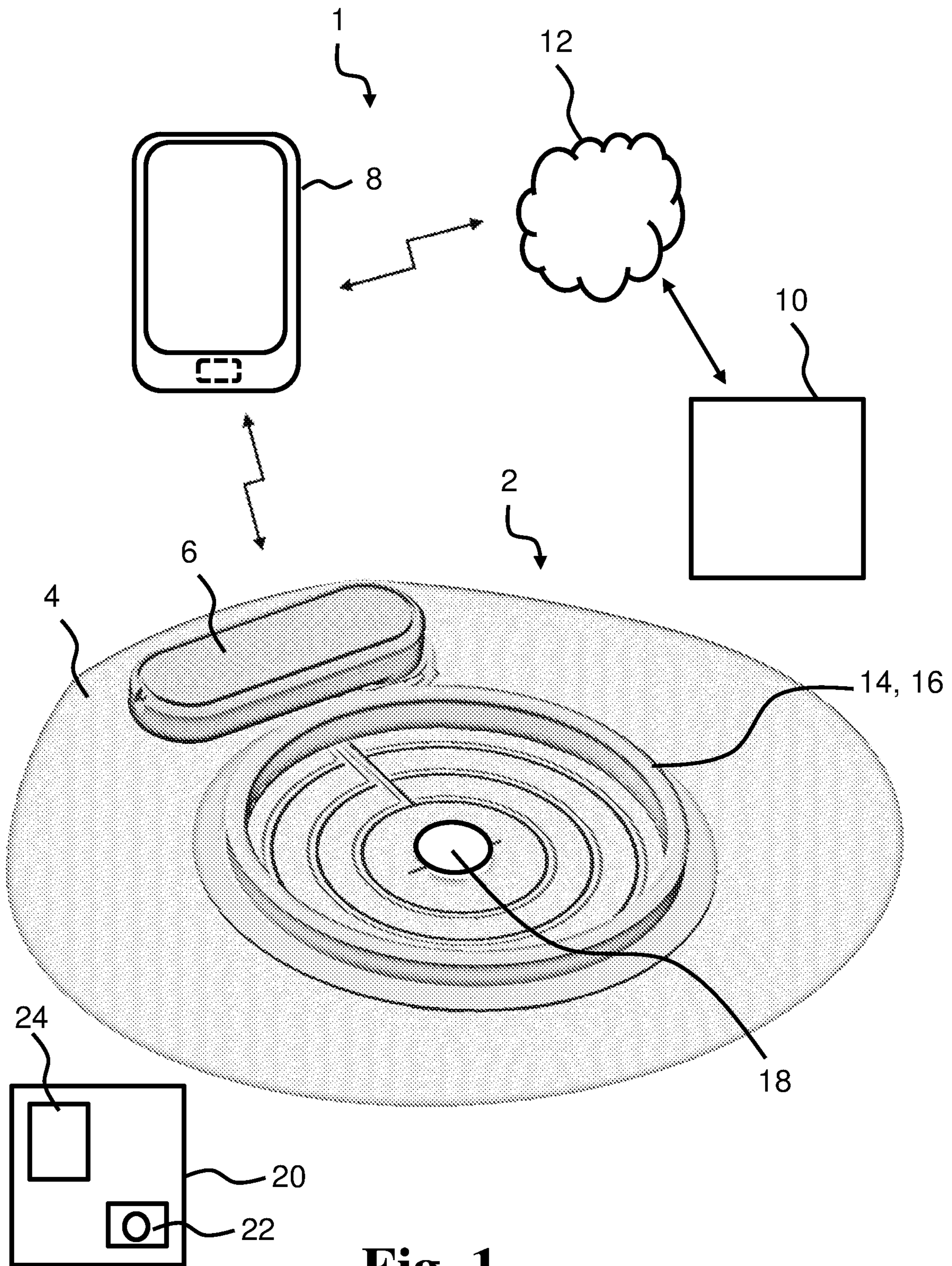

Fig. 1

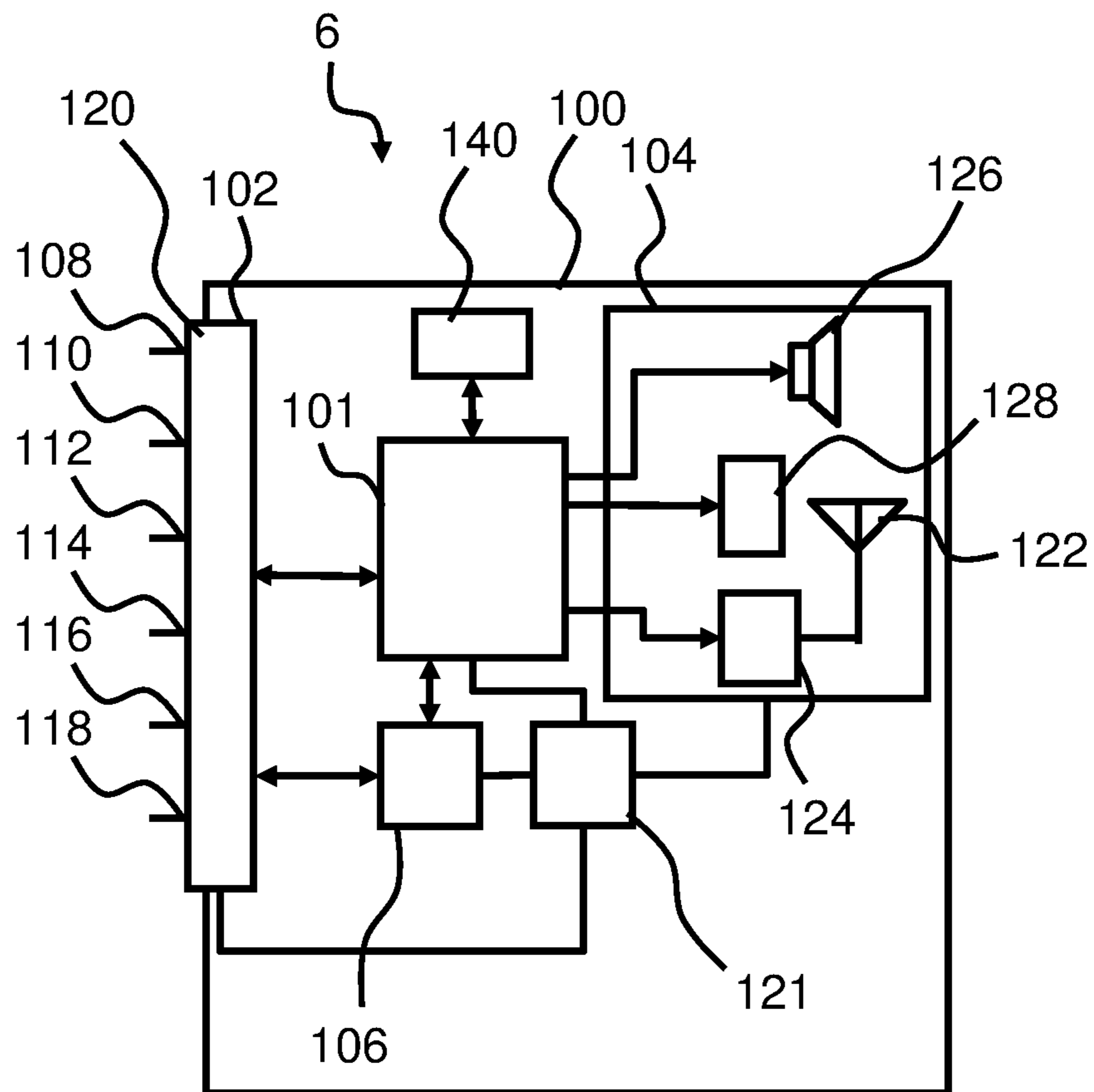

Fig. 2

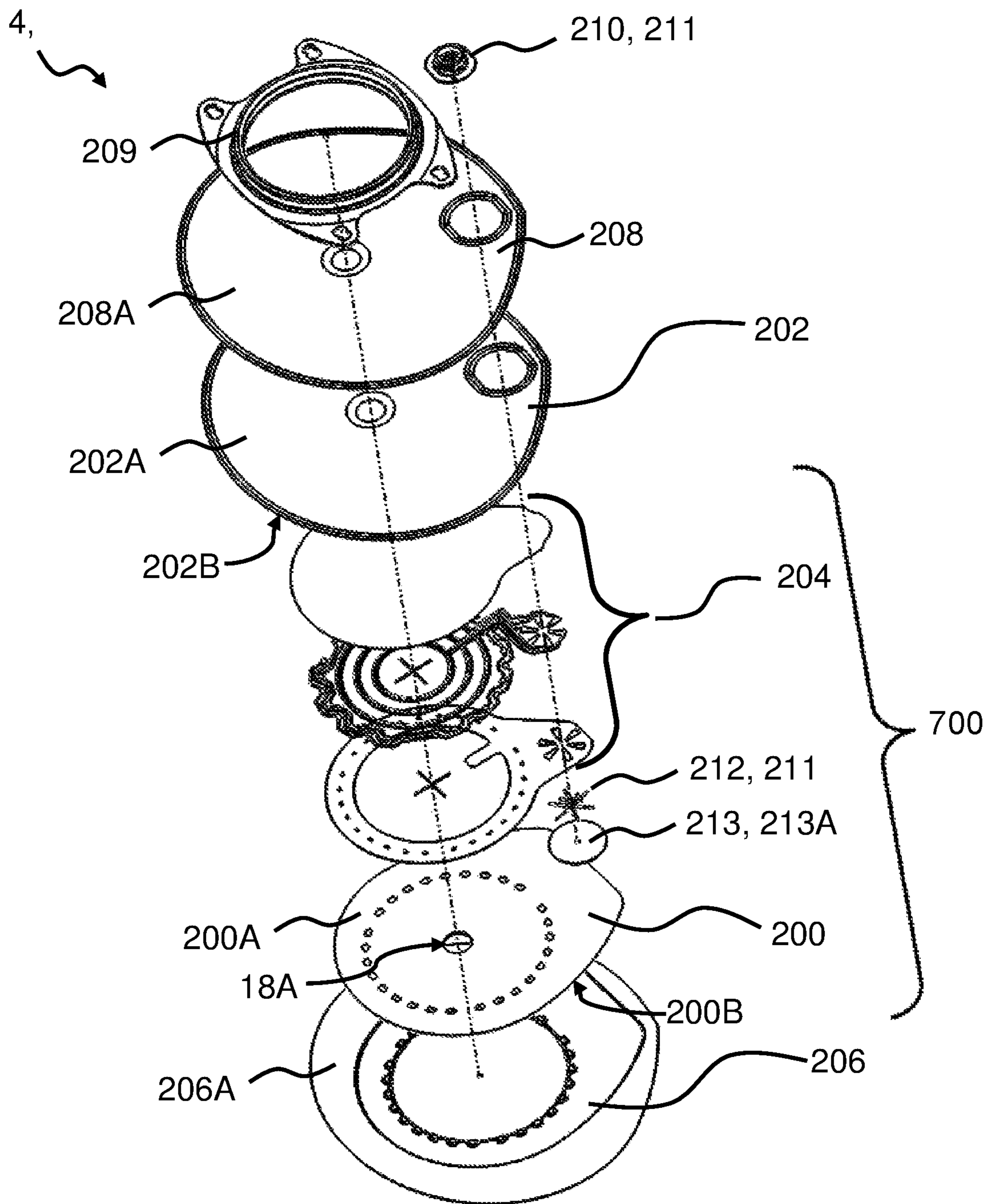

Fig. 3

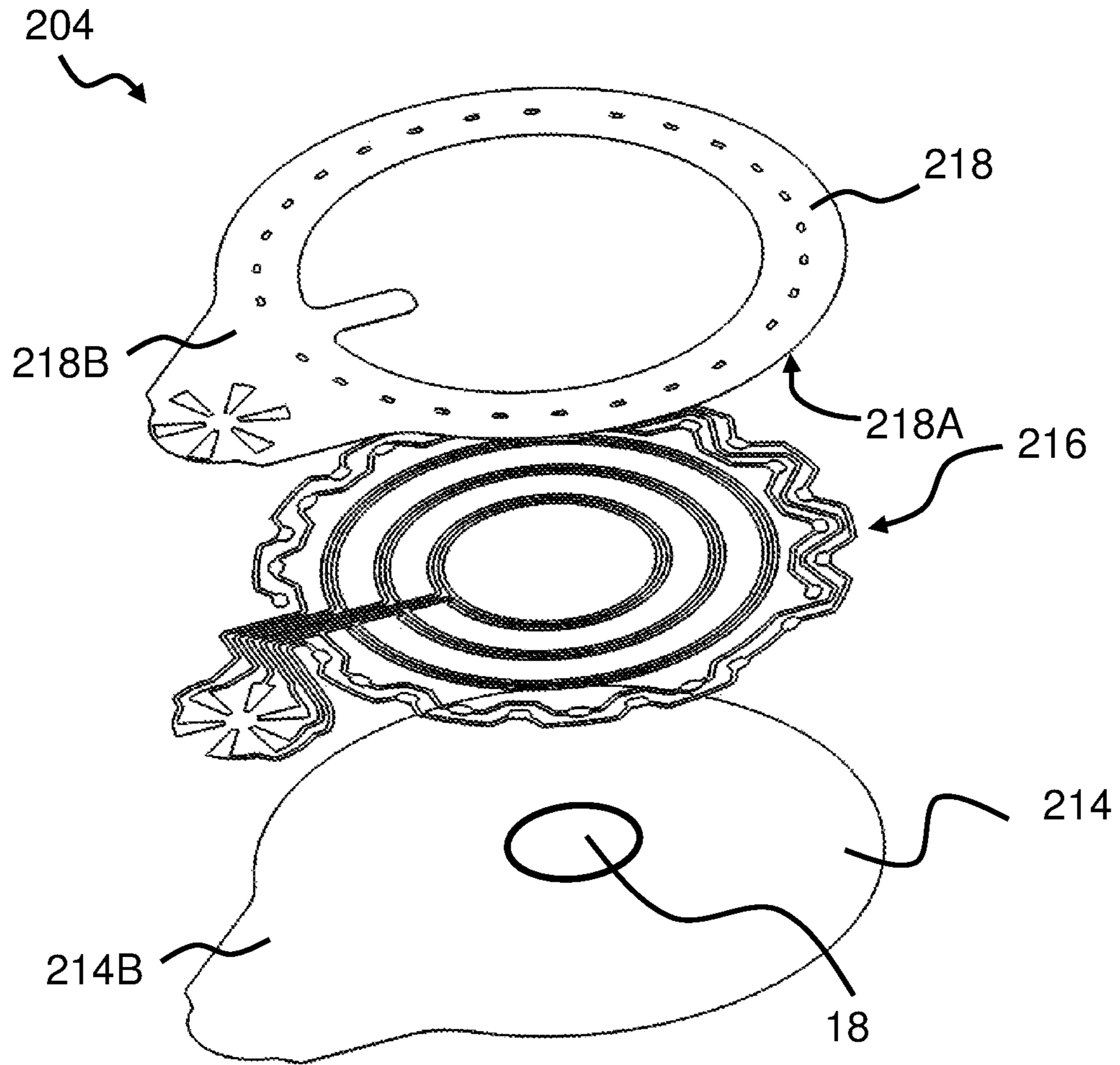

Fig. 4

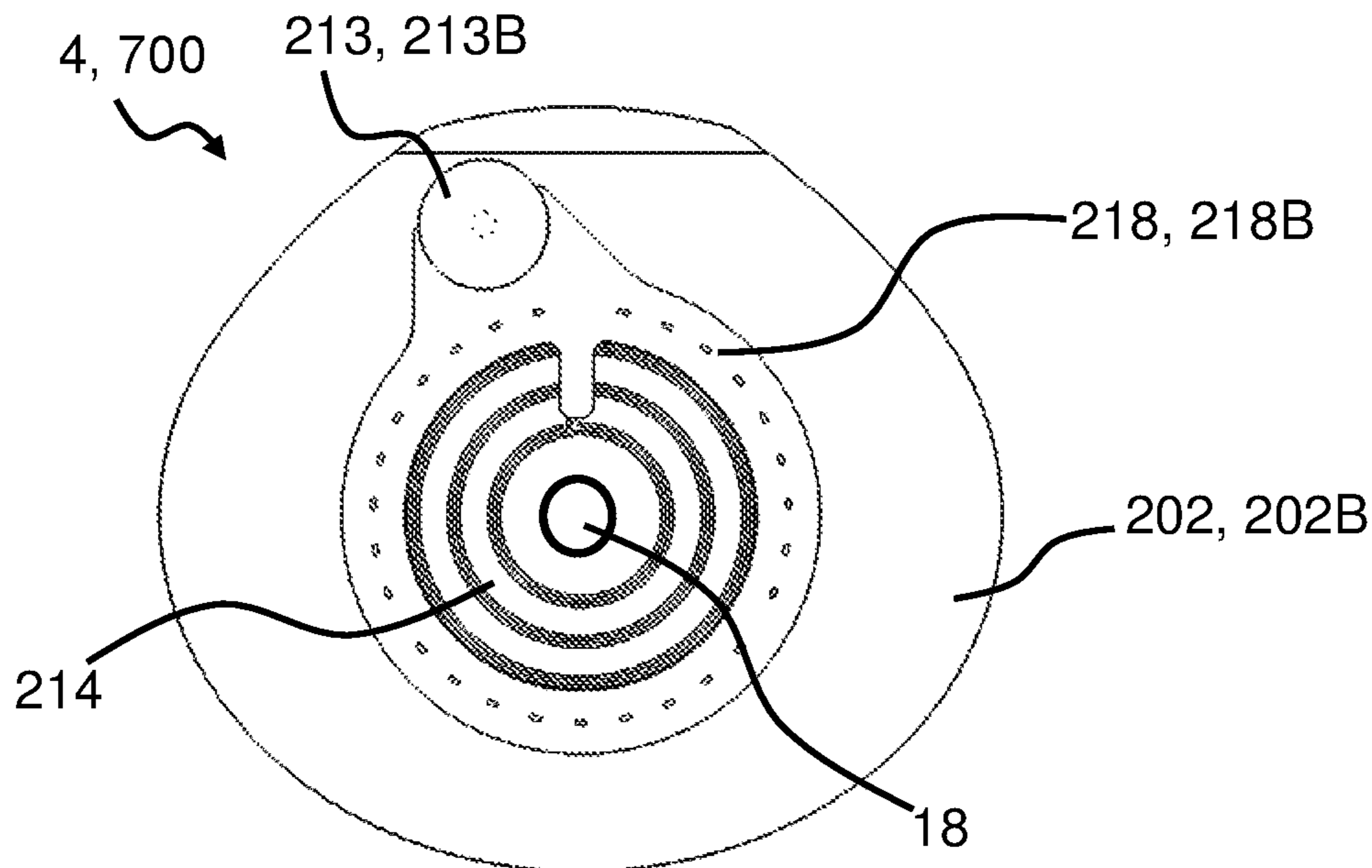

Fig. 5

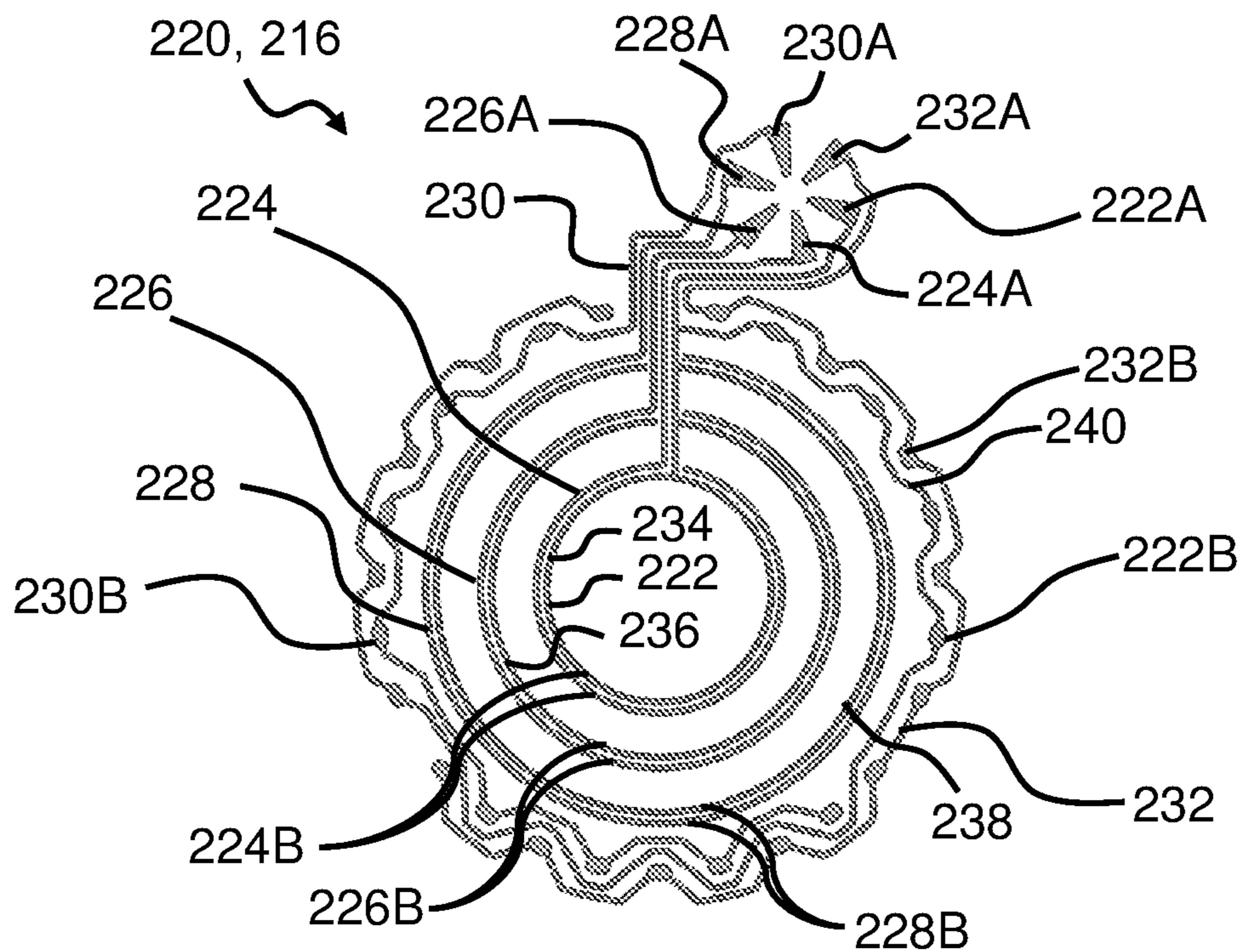

Fig. 6

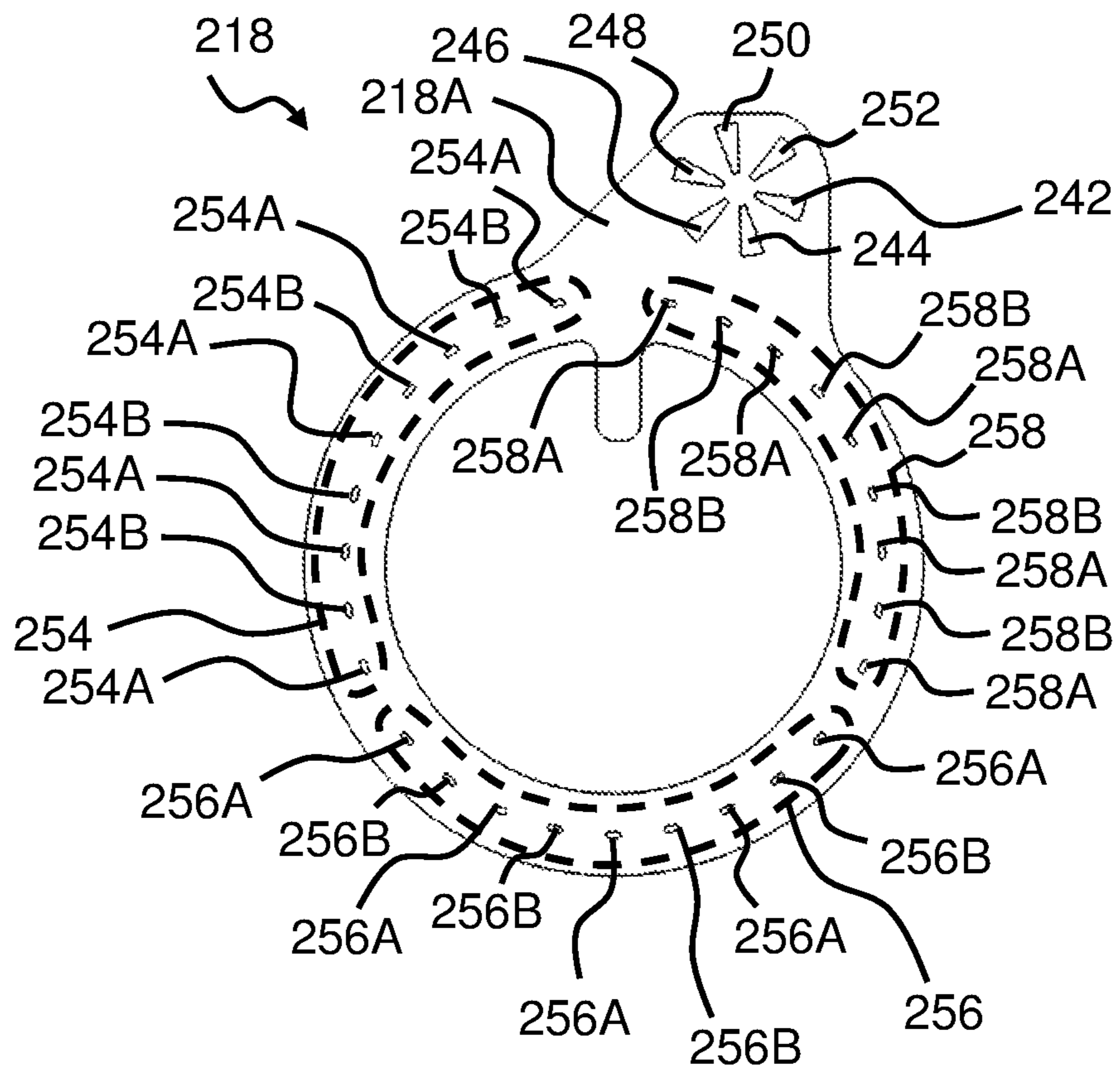

Fig. 7

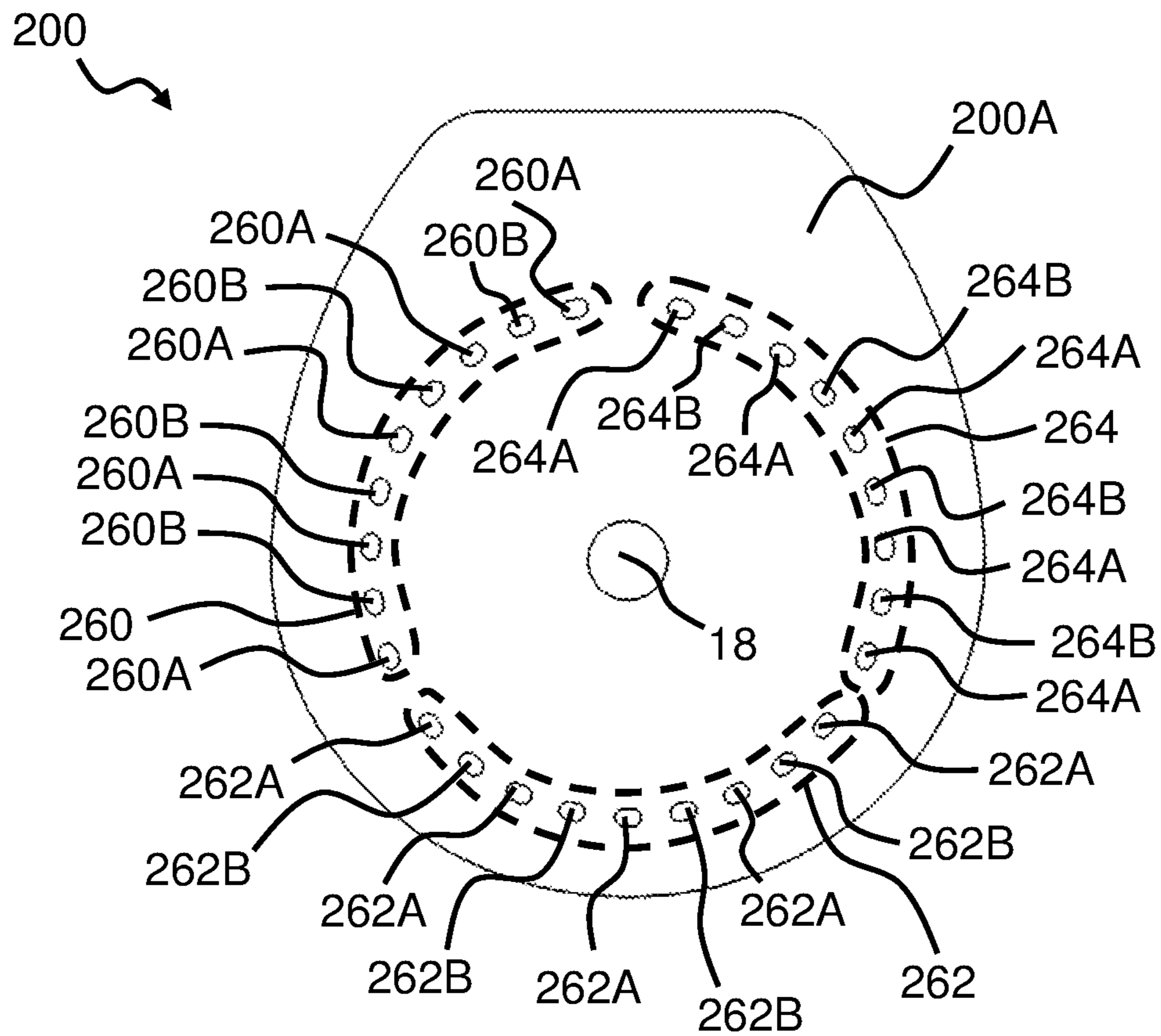

Fig. 8

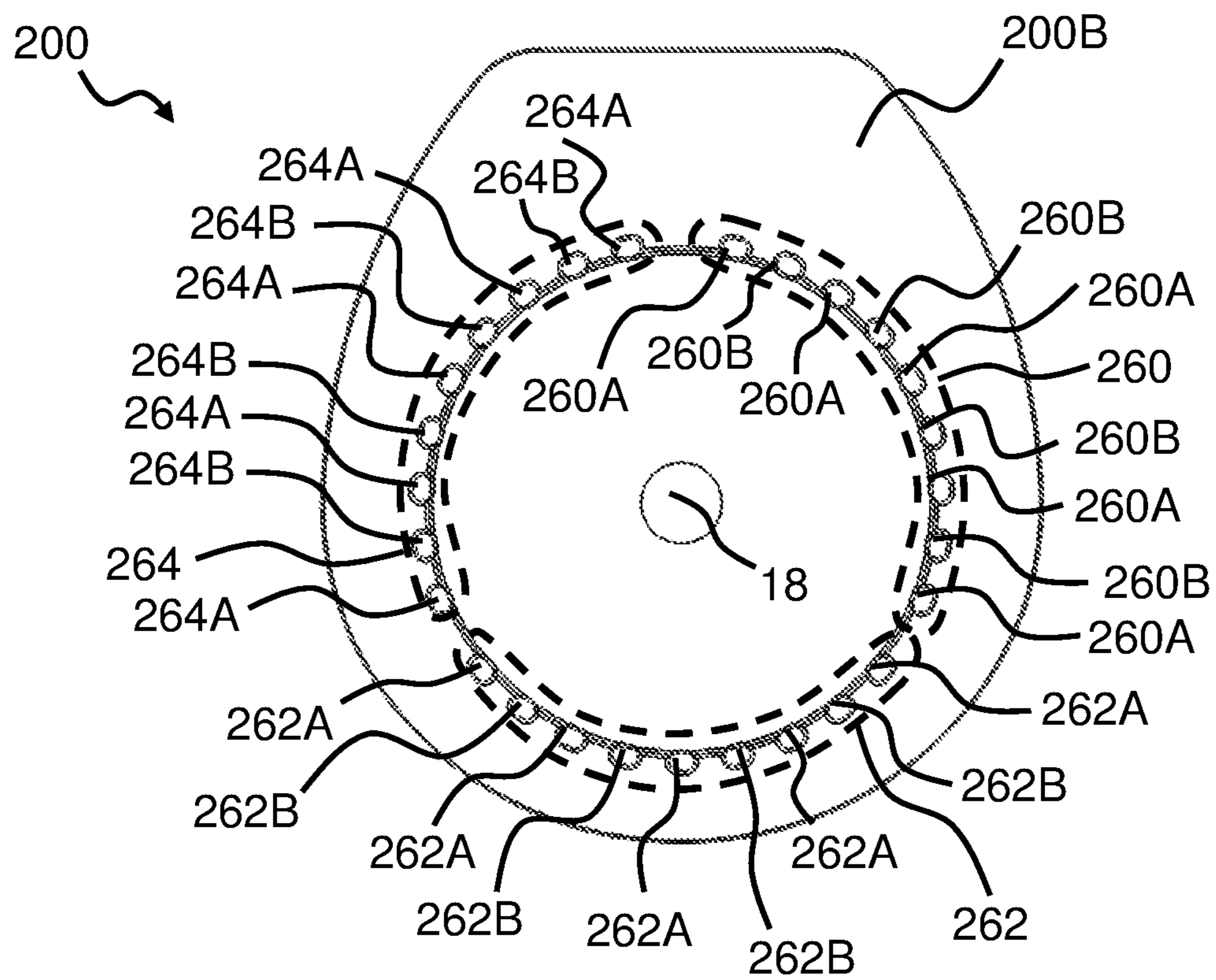

Fig. 9

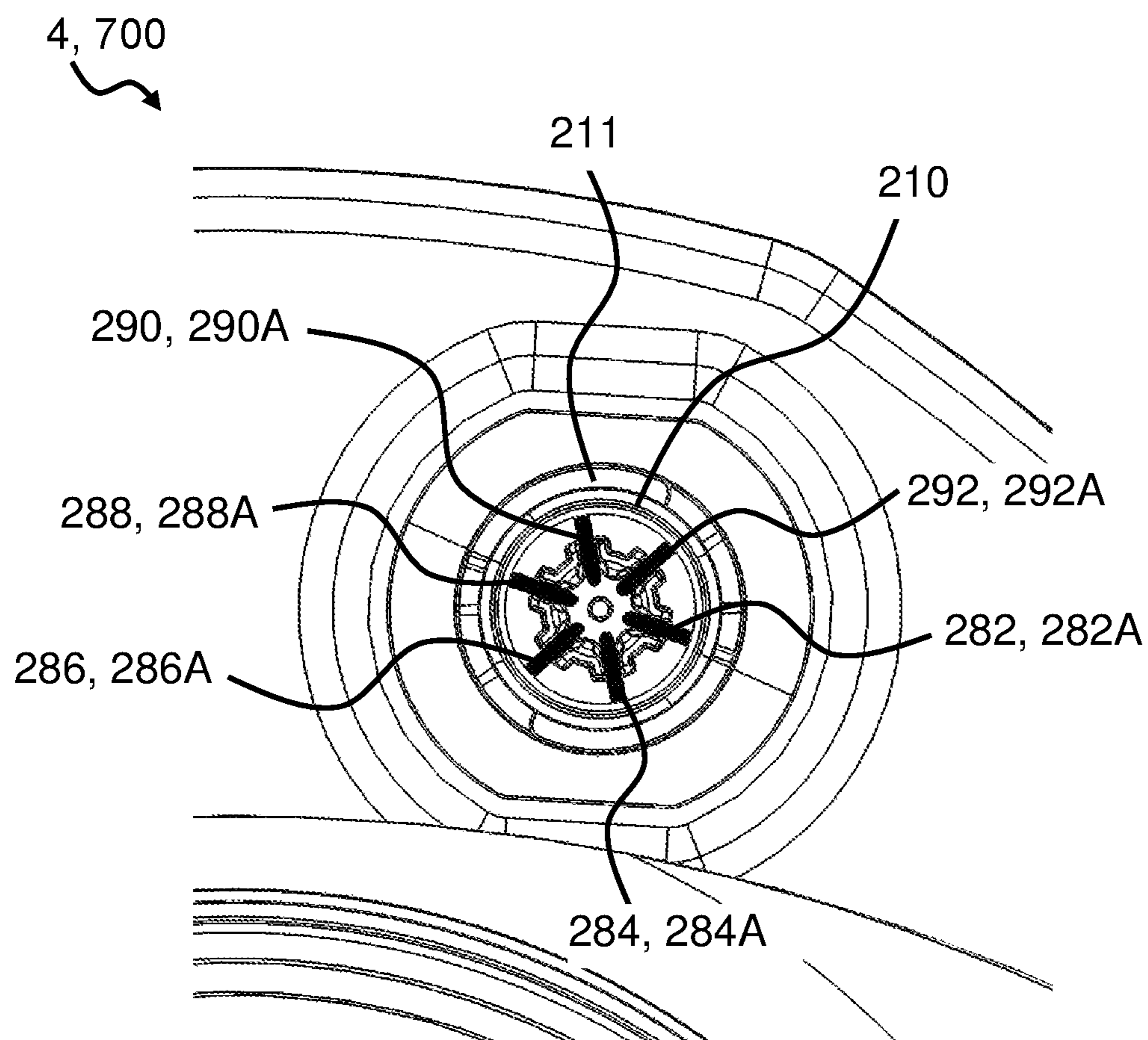

Fig. 10

**MEDICAL APPLIANCE WITH LAYERED
BASE PLATE AND/OR SENSOR ASSEMBLY
PART AND RELATED METHODS**

The present disclosure relates to an ostomy system, devices thereof and method for manufacturing an ostomy appliance. The ostomy appliance system comprises an ostomy appliance and an ostomy monitor device. In particular, the present disclosure relates to a base plate and/or a sensor assembly part of an ostomy appliance including electrodes for detecting and monitoring the operation of an ostomy appliance.

BRIEF DESCRIPTION OF THE DRAWINGS

The accompanying drawings are included to provide a further understanding of embodiments and are incorporated into and a part of this specification. The drawings illustrate embodiments and together with the description serve to explain principles of embodiments. Other embodiments and many of the intended advantages of embodiments will be readily appreciated as they become better understood by reference to the following detailed description. The elements of the drawings are not necessarily to scale relative to each other. Like reference numerals designate corresponding similar parts.

FIG. 1 illustrates an exemplary ostomy system,

FIG. 2 illustrates an exemplary monitor device of the ostomy system,

FIG. 3 is an exploded view of a base plate of an ostomy appliance,

FIG. 4 is an exploded view of an exemplary electrode assembly,

FIG. 5 is a proximal view of parts of a base plate and/or a sensor assembly part,

FIG. 6 is a distal view of an exemplary electrode configuration,

FIG. 7 is a distal view of an exemplary masking element,

FIG. 8 is a distal view of an exemplary first adhesive layer,

FIG. 9 is a proximal view of the first adhesive layer of FIG. 8,

FIG. 10 is a distal view of a part of the base plate and/or sensor assembly part including a monitor interface.

DETAILED DESCRIPTION

Various exemplary embodiments and details are described hereinafter, with reference to the figures when relevant. It should be noted that the figures may or may not be drawn to scale and that elements of similar structures or functions are represented by like reference numerals throughout the figures. It should also be noted that the figures are only intended to facilitate the description of the embodiments. They are not intended as an exhaustive description of the invention or as a limitation on the scope of the invention. In addition, an illustrated embodiment needs not have all the aspects or advantages shown. An aspect or an advantage described in conjunction with a particular embodiment is not necessarily limited to that embodiment and can be practiced in any other embodiments even if not so illustrated, or if not so explicitly described.

Throughout this disclosure, the words “stoma” and “ostomy” are used to denote a surgically created opening bypassing the intestines or urinary tract system of a person. The words are used interchangeably, and no differentiated meaning is intended. The same applies for any words or

phrases derived from these, e.g. “stomal”, “ostomies” etc. Also, the solid and liquid wastes emanating from the stoma may be referred to as both stomal “output,” “waste(s),” and “fluids” interchangeably. A subject having undergone ostomy surgery may be referred to as “ostomist” or “ostomate”—moreover, also as “patient” or “user”. However, in some cases “user” may also relate or refer to a health care professional (HCP), such as a surgeon or an ostomy care nurse or others. In those cases, it will either be explicitly stated, or be implicit from the context that the “user” is not the “patient” him- or herself.

In the following, whenever referring to proximal side or surface of a layer, an element, a device or part of a device, the referral is to the skin-facing side or surface, when a user wears the ostomy appliance. Likewise, whenever referring to the distal side or surface of a layer, an element, a device or part of a device, the referral is to the side or surface facing away from the skin, when a user wears the ostomy appliance. In other words, the proximal side or surface is the side or surface closest to the user, when the appliance is fitted on a user and the distal side is the opposite side or surface—the side or surface furthest away from the user in use.

The axial direction is defined as the direction of the stoma, when a user wears the appliance. Thus, the axial direction is generally perpendicular to the skin or abdominal surface of the user.

The radial direction is defined as perpendicular to the axial direction. In some sentences, the words “inner” and “outer” may be used. These qualifiers should generally be perceived with respect to the radial direction, such that a reference to an “outer” element means that the element is farther away from a centre portion of the ostomy appliance than an element referenced as “inner”. In addition, “innermost” should be interpreted as the portion of a component forming a centre of the component and/or being adjacent to the centre of the component. In analogy, “outermost” should be interpreted as a portion of a component forming an outer edge or outer contour of a component and/or being adjacent to that outer edge or outer contour.

The use of the word “substantially” as a qualifier to certain features or effects in this disclosure is intended to simply mean that any deviations are within tolerances that would normally be expected by the skilled person in the relevant field.

The use of the word “generally” as a qualifier to certain features or effects in this disclosure is intended to simply mean—for a structural feature: that a majority or major portion of such feature exhibits the characteristic in question, and—for a functional feature or an effect: that a majority of outcomes involving the characteristic provide the effect, but that exceptionally outcomes do not provide the effect.

The present disclosure relates to an ostomy system and devices thereof, such as an ostomy appliance, a base plate for an ostomy appliance, a monitor device, and optionally one or more accessory devices. Further, methods related to the ostomy system and devices thereof are disclosed. An accessory device (also referred to as an external device) may be a mobile phone or other handheld device. An accessory device may be a personal electronic device, e.g. a wearable, such as a watch or other wrist-worn electronic device. An accessory device may be a docking station. The docking station may be configured to electrically and/or mechanically couple the monitor device to the docking station. The docking station may be configured for charging the monitor device and/or configured for transferring data between the monitor device and the docking station. The ostomy system

may comprise a server device. The server device may be operated and/or controlled by the ostomy appliance manufacturer, the accessory device, and/or a service centre.

The present disclosure provides an ostomy system and devices thereof, such as an ostomy appliance, a base plate for an ostomy appliance, a monitor device, and optionally one or more accessory devices which either alone or together facilitate reliable determination of the nature, severity and rapidness of moisture propagation in the adhesive material provided for attaching the base plate to the skin surface of a user. Depending on the nature of the pattern of moisture propagation in the adhesive, the ostomy system and devices thereof enable providing information to the user about the type of failure, and in turn enable providing an indication to the user of the severity and thus the remaining time frame for replacing the ostomy appliance without experiencing severe leakage and/or skin damage.

The ostomy appliance comprises a base plate and an ostomy pouch (also referred to as an ostomy bag). The ostomy appliance may be a colostomy appliance, an ileostomy appliance or a urostomy appliance. The ostomy appliance may be a two-part ostomy appliance, i.e. the base plate and the ostomy pouch may be releasably coupled e.g. with a mechanical and/or an adhesive coupling, e.g. to allow that a plurality of ostomy pouches can be utilized (exchanged) with one base plate. Further, a two-part ostomy appliance may facilitate correct application of the base plate to skin, e.g. to an improved user sight of the stomal region. The ostomy appliance may be a one-part ostomy appliance, i.e. the base plate and the ostomy pouch may be fixedly attached to each other. The base plate is configured for coupling to a user's stoma and/or skin surrounding the stoma, such as a peristomal skin area.

The ostomy appliance includes a base plate, such as a monolithic, one-piece base plate, e.g. integrated with a sensor assembly part, or a base plate and a separate sensor assembly part, such as a sensor assembly part to be subsequently applied to a base plate. For example, to allow an arbitrary base plate, such as a conventional base plate, to achieve the features as described herein. Features as described with respect to the base plate herein may be provided by a sensor assembly part to be applied to a base plate, e.g. by the user. A sensor assembly part may be adapted to adhere to an ostomy plate.

A disclosed method of attaching a base plate to a user's stoma and/or skin surrounding the stoma, such as the peristomal skin area, may comprise attaching a sensor assembly part to a base plate and attaching the base plate, e.g. together with the attached sensor assembly part, to the user's stoma and/or skin surrounding the stoma, such as the peristomal skin area. Alternatively, the method of attaching the base plate to the user's stoma and/or skin surrounding the stoma may comprise attaching the sensor assembly part to the user's stoma and/or skin surrounding the stoma and attaching the base plate to the user's stoma and/or skin surrounding the stoma above the attached sensor assembly part.

The base plate and/or the sensor assembly part may comprise a first adhesive layer, also denoted center adhesive layer. During use, the first adhesive layer adheres to the user's skin (peristomal area) and/or to additional seals, such as sealing paste, sealing tape and/or sealing ring. Thus, the first adhesive layer may be configured for attachment of the base plate and/or the sensor assembly part to the skin surface of a user. The first adhesive layer may have a stomal opening, such as a first adhesive stomal opening, with a center point.

The first adhesive layer may be made of a first composition. The first composition may comprise one or more polyisobutenes and/or styrene-isoprene-styrene. The first composition may comprise one or more hydrocolloids. The first composition may comprise one or more water soluble or water swellable hydrocolloids.

The first composition may be a pressure sensitive adhesive composition suitable for medical purposes comprising a rubbery elastomeric base and one or more water soluble or water swellable hydrocolloids. The first composition may comprise one or more polybutenes, one or more styrene copolymers, one or more hydrocolloids, or any combination thereof. The combination of the adhesive properties of the polybutenes and the absorbing properties of the hydrocolloids renders the first composition suitable for use in ostomy appliances. The styrene copolymer may for example be a styrene-butadiene-styrene block copolymer or a styrene-isoprene-styrene block copolymer. Preferably, one or more styrene-isoprene-styrene (SIS) block type copolymers are employed. The amount of styrene block-copolymer may be from 5% to 20% of the total adhesive composition. The butene component is suitably a conjugated butadiene polymer selected from polybutadiene, polyisoprene. The polybutenes are preferably present in an amount of from 35-50% of the total adhesive composition. Preferably, the polybutene is polyisobutylene (PIB). Suitable hydrocolloids for incorporation in the first composition are selected from naturally occurring hydrocolloids, semisynthetic hydrocolloids and synthetic hydrocolloids. The first composition may comprise 20-60% hydrocolloids. A preferred hydrocolloid is carboxymethylcellulose (CMC). The first composition may optionally contain other components, such as fillers, tackifiers, plasticizers, and other additives.

The first adhesive layer may have a plurality of sensor point openings. A sensor point opening of the first adhesive layer is optionally configured to overlap a part of an electrode, e.g. to form a sensor point.

The sensor point openings of the first adhesive layer may comprise primary sensor point openings. The primary sensor point openings may comprise one or more primary first sensor point openings and one or more primary second sensor point openings, the primary first sensor point openings configured to overlap parts of an electrode and the primary second sensor point openings configured to overlap parts of another electrode different from the electrode at least partly overlapped by the primary first sensor point openings.

The sensor point openings of the first adhesive layer may comprise secondary sensor point openings. The secondary sensor point openings may comprise one or more secondary first sensor point openings and one or more secondary second sensor point openings, the secondary first sensor point openings configured to overlap parts of an electrode and the secondary second sensor point openings configured to overlap parts of another electrode different from the electrode at least partly overlapped by the secondary first sensor point openings.

The sensor point openings of the first adhesive layer may comprise tertiary sensor point openings. The tertiary sensor point openings may comprise one or more tertiary first sensor point openings and one or more tertiary second sensor point openings, the tertiary first sensor point openings configured to overlap parts of an electrode and the tertiary second sensor point openings configured to overlap parts of another electrode different from the electrode at least partly overlapped by the tertiary first sensor point openings.

The first adhesive layer may have a substantially uniform thickness. The first adhesive layer may have a thickness in the range from 0.1 mm to 1.5 mm, e.g. in the range from 0.2 mm to 1.2 mm.

The first adhesive layer may have a primary thickness in a primary part of the first adhesive layer, e.g. in a primary region within a primary radial distance or in a primary radial distance range from the center point of the stomal opening. The primary thickness may be in the range from 0.2 mm to 1.5 mm, such as about 1.0 mm. The primary radial distance may be in the range from 20 mm to 50 mm, such as in the range from 25 mm to 35 mm, e.g. 30 mm.

The first adhesive layer may have a secondary thickness in a secondary part of the first adhesive layer, e.g. in a secondary region outside a secondary radial distance or in a secondary radial distance range from the center point of the stomal opening. The secondary thickness may be in the range from 0.2 mm to 1.0 mm, such as about 0.5 mm. The secondary radial distance may be in the range from 20 mm to 50 mm, such as in the range from 25 mm to 35 mm, e.g. 30 mm.

The base plate and/or the sensor assembly part may comprise a second layer. The second layer may be an adhesive layer, also denoted rim adhesive layer. The second layer may have a second radial extension that is larger than a first radial extension of the first adhesive layer at least in a first angular range of the base plate and/or the sensor assembly part. Accordingly, a part of a proximal surface of the second layer may be configured for attachment to the skin surface of a user. The part of a proximal surface of the second layer configured for attachment to the skin surface of a user is also denoted the skin attachment surface of the second adhesive layer. The second layer may have a stomal opening, such as a second layer stomal opening and/or a second adhesive stomal opening, with a center point.

The second adhesive layer may be made of a second composition. The second composition may comprise one or more polyisobutenes and/or styrene-isoprene-styrene. The second composition may comprise one or more hydrocolloids. The second composition may comprise one or more water soluble or water swellable hydrocolloids.

The second composition may be a pressure sensitive adhesive composition suitable for medical purposes comprising a rubbery elastomeric base and one or more water soluble or water swellable hydrocolloids. The second composition may comprise one or more polybutenes, one or more styrene copolymers, one or more hydrocolloids, or any combination thereof. The combination of the adhesive properties of the polybutenes and the absorbing properties of the hydrocolloids renders the second composition suitable for use in ostomy appliances. The styrene copolymer may for example be a styrene-butadiene-styrene block copolymer or a styrene-isoprene-styrene block copolymer. Preferably, one or more styrene-isoprene-styrene (SIS) block type copolymers are employed. The amount of styrene block-copolymer may be from 5% to 20% of the total adhesive composition. The butene component is suitably a conjugated butadiene polymer selected from polybutadiene, polyisoprene. The polybutenes are preferably present in an amount of from 35-50% of the total adhesive composition. Preferably, the polybutene is polyisobutylene (PIB). Suitable hydrocolloids for incorporation in the second composition are selected from naturally occurring hydrocolloids, semisynthetic hydrocolloids and synthetic hydrocolloids. The second composition may comprise 20-60% hydrocolloids. A preferred hydrocolloid is carboxymethylcellulose (CMC). The second

composition may optionally contain other components, such as fillers, tackifiers, plasticizers, and other additives.

Different ratio of contents may change properties of the first and/or second adhesive layers. The second adhesive layer and the first adhesive layer may have different properties. The second adhesive layer (second composition) and the first adhesive layer (first composition) may have different ratios of polyisobutenes, styrene-isoprene-styrene, and/or hydrocolloids. For example, the second adhesive layer may provide a stronger attachment to the skin compared to attachment to the skin provided by the first adhesive layer. Alternatively or additionally, the second adhesive layer may be thinner than the first adhesive layer. Alternatively or additionally, the second adhesive layer may be less water and/or sweat absorbing than the first adhesive layer. Alternatively or additionally, the second adhesive layer may be less mouldable than the first adhesive layer. The second adhesive layer may provide a second barrier against leakage.

The second layer may have a substantially uniform thickness. The second layer may have a thickness in the range from 0.1 mm to 1.5 mm, e.g. in the range from 0.2 mm to 1.0 mm, such as 0.5 mm, 0.6 mm, or 0.7 mm.

The base plate and/or the sensor assembly part may comprise one or more electrodes, such as a plurality of electrodes, such as two, three, four, five, six, seven or more electrodes. The sensor assembly part may be applied to the base plate, such as to provide the base plate with the one or more electrodes.

The electrodes, e.g. some or all the electrodes, may be arranged between the first adhesive layer and the second adhesive layer. The electrodes may be arranged in an electrode assembly, e.g. an electrode layer. In embodiments, the electrode layer may be formed as a water sealing or a water transparent structure to allow water transport from the first adhesive layer to the second adhesive layer. An electrode comprises a connection part for connecting the electrodes to other components and/or interface terminals/terminal elements. An electrode may comprise one or more conductor parts and/or one or more sensing parts. A conductor part may be considered part of an electrode connecting two or more sensing parts, and/or connecting a sensing part with a connection part of the respective electrode. A sensing part may be considered a part of the electrode being suitable for sensing, e.g. liquid, such as liquid content, and/or output, such as output resulting from a leakage, or an imminent leakage. The sensing part may be suitable for sensing e.g. by its shape, said shape potentially being circular, oval, or rectangular. Thus, the conductor part may conduct a signal arising from the sensing part. An electrode may comprise alternating conductor parts and sensing parts. The electrode assembly may be arranged between the first adhesive layer and the second adhesive layer. The base plate and/or the sensor assembly part, e.g. the electrode assembly, may comprise a first electrode, a second electrode and optionally a third electrode. The base plate and/or the sensor assembly part, e.g. the electrode assembly, may comprise a fourth electrode and/or a fifth electrode. The base plate and/or the sensor assembly part, e.g. the electrode assembly, optionally comprises a sixth electrode. The base plate and/or the sensor assembly part, e.g. the electrode assembly, may comprise a ground electrode. The ground electrode may comprise a first electrode part. The first electrode part of the ground electrode may form a ground for the first electrode. The ground electrode may comprise a second electrode part. The second electrode part of the ground electrode may form a ground for the second electrode. The ground electrode may comprise a third electrode part. The third electrode part of the ground

electrode may form a ground for the third electrode. The ground electrode may comprise a fourth electrode part. The fourth electrode part of the ground electrode may form a ground for the fourth electrode and/or the fifth electrode.

The ground electrode or electrode parts of the ground electrode may be configured as or form a (common) reference electrode for some or all of the other electrodes of the electrode assembly. The ground electrode may also be denoted reference electrode.

The electrodes are electrically conductive and may comprise one or more of metallic (e.g. silver, copper, gold, titanium, aluminium, stainless steel), ceramic (e.g. ITO), polymeric (e.g. PEDOT, PANI, PPy), and carbonaceous (e.g. carbon black, carbon nanotube, carbon fibre, graphene, graphite) materials.

Two electrodes of the electrode assembly may form a sensor. The first electrode and the ground electrode (e.g. first electrode part of the ground electrode) may form a first sensor or first electrode pair. The second electrode and the ground electrode (e.g. second electrode part of the ground electrode) may form a second sensor or second electrode pair. The third electrode and the ground electrode (e.g. third electrode part of the ground electrode) may form a third sensor or third electrode pair. The fourth electrode and the ground electrode (e.g. fourth electrode part of the ground electrode) may form a fourth sensor or fourth electrode pair. The fifth electrode and the ground electrode (e.g. fifth electrode part of the ground electrode) may form a fifth sensor or fifth electrode pair.

The first electrode may form an open loop. The second electrode may form an open loop and/or the third electrode may form an open loop. The fourth electrode may form an open loop. The fifth electrode may form an open loop. Open loop electrode(s) enables electrode arrangement in few or a single electrode layer.

The electrode assembly may comprise a support layer, also denoted a support film. One or more electrodes may be formed, e.g. printed, on the proximal side of the support layer. One or more electrodes may be formed, e.g. printed, on the distal side of the support layer. The electrode assembly, such as the support layer of the electrode assembly, may have a stomal opening, such as an electrode assembly stomal opening and/or a support layer stomal opening, with a center point.

The support layer may comprise polymeric (e.g. polyurethane, PTFE, PVDF) and/or ceramic (e.g. alumina, silica) materials. In one or more exemplary base plates and/or sensor assembly parts, the support layer is made of thermoplastic polyurethane (TPU). The support layer material may be made of or comprise one or more of polyester, a thermoplastic elastomer (TPE), polyimide, polyimide, Ethylene-vinyl acetate (EVA), polyurea, and silicones.

Exemplary thermoplastic elastomers of the support layer are styrenic block copolymers (TPS, TPE-s), thermoplastic polyolefinelastomers (TPO, TPE-o), thermoplastic Vulcanizates (TPV, TPE-v), thermoplastic polyurethanes (TPU), thermoplastic copolyester (TPC, TPE-E), and thermoplastic polyamides (TPA, TPE-A).

The base plate and/or the sensor assembly part, such as the electrode assembly may comprise a masking element configured to insulate at least parts of the electrodes from the first adhesive layer of the base plate and/or the sensor assembly part. Thus, the masking element may be more insulative, such as less electrically conductive and/or less moisture-permeable than other layers of the base plate and/or sensor assembly part, such as more insulative than the first adhesive layer. The masking element may be arranged

between the electrodes and the first adhesive layer. For example, the masking element may be arranged between the conductor parts of the plurality of electrodes and the first adhesive layer. Alternatively or additionally, the masking element optionally is not arranged between the sensing parts of the plurality of electrodes and the first adhesive layer, e.g. the masking element may be arranged such as to not separate the sensing parts of the plurality of electrodes and the first adhesive layer.

The masking element may comprise one or more, such as a plurality of, sensor point openings. The sensor point openings may comprise primary sensor point openings and/or secondary sensor point openings. The sensor point openings may comprise tertiary sensor point opening(s). The sensor point openings may comprise quaternary sensor point opening(s) A sensor point opening of the masking element overlaps at least one electrode of the electrode assembly when seen in the axial direction, e.g. to form a sensor point. For example, a primary sensor point opening may overlap a part of the ground electrode and/or a part of the fourth electrode. A secondary sensor point opening may overlap a part of the fourth electrode and/or a part of the fifth electrode. A tertiary sensor point opening may overlap a part of the fifth electrode and/or a part of the ground electrode.

The masking element may comprise one or more, such as a plurality of, terminal openings. The masking element may comprise polymeric (e.g. polyurethane, PTFE, PVDF) and/or ceramic (e.g. alumina, silica) materials. In one or more exemplary base plates and/or sensor assembly parts, the masking element is made of or comprises thermoplastic polyurethane (TPU). In one or more exemplary base plates and/or sensor assembly parts, the masking element is made of or comprises polyester. The masking element material may be made of or comprise one or more of polyester, a thermoplastic elastomer (TPE), polyimide, polyimide, Ethylene-vinyl acetate (EVA), polyurea, and silicones.

Exemplary thermoplastic elastomers of the masking element are styrenic block copolymers (TPS, TPE-s), thermoplastic polyolefinelastomers (TPO, TPE-o), thermoplastic Vulcanizates (TPV, TPE-v), thermoplastic polyurethanes (TPU), thermoplastic copolyester (TPC, TPE-E), and thermoplastic polyamides (TPA, TPE-A).

The base plate and/or the sensor assembly part may comprise a first intermediate element. The first intermediate element may be arranged between the electrodes/electrode layer and the first adhesive layer and/or between the second layer and the first adhesive layer. The first intermediate layer may be made of an insulating material.

The base plate and/or the sensor assembly part may comprise a release liner. The release liner is a protective layer that protects adhesive layer(s) during transport and storage and is peeled off by the user prior to applying the base plate and/or the sensor assembly part on the skin. The release liner may have a stomal opening, such as a release liner stomal opening, with a center point.

The base plate and/or the sensor assembly part may comprise a top layer. The top layer is a protective layer protecting the adhesive layer(s) from external strains and stress when the user wears the ostomy appliance. The electrodes, e.g. some or all the electrodes, may be arranged between the first adhesive layer and the top layer. The top layer may have a stomal opening, such as a top layer stomal opening, with a center point. The top layer may have a thickness in the range from 0.01 mm to 1.0 mm, e.g. in the range from 0.02 mm to 0.2 mm, such as 0.04 mm.

The base plate and/or the sensor assembly part may comprise a monitor interface. The monitor interface may be

configured for electrically and/or mechanically connecting the ostomy appliance (base plate and/or sensor assembly part) to the monitor device. The monitor interface may be configured for wirelessly connecting the ostomy appliance (base plate and/or sensor assembly part) to the monitor device. Thus, the monitor interface of the base plate and/or the sensor assembly part is configured to electrically and/or mechanically couple the ostomy appliance and the monitor device.

The monitor interface of the base plate and/or of the sensor assembly part may comprise, e.g. as part of a first connector of the monitor interface, a coupling part for forming a mechanical connection, such as a releasable coupling between the monitor device and the base plate and/or the sensor assembly part. The coupling part may be configured to engage with a coupling part of the monitor device for releasably coupling the monitor device to the base plate and/or the sensor assembly part.

The monitor interface of the base plate and/or the sensor assembly part may comprise, e.g. as part of a first connector of the monitor interface, a plurality of terminals, such as two, three, four, five, six, seven or more terminals, for forming electrical connections with respective terminals of the monitor device. The monitor interface may comprise a ground terminal element forming a ground terminal. The monitor interface may comprise a first terminal element forming a first terminal, a second terminal element forming a second terminal and optionally a third terminal element forming a third terminal. The monitor interface may comprise a fourth terminal element forming a fourth terminal and/or a fifth terminal element forming a fifth terminal. The monitor interface optionally comprises a sixth terminal element forming a sixth terminal. The terminal elements of the monitor interface may contact respective electrodes of the base plate and/or the sensor assembly part, such as the electrode assembly. The first intermediate element may be arranged between the terminal elements and the first adhesive layer. The first intermediate element may cover or overlap terminal element(s) of the base plate and/or the sensor assembly part when seen in the axial direction. Thus, the first adhesive layer may be protected or experience more evenly distributed mechanical stress from the terminal elements of the base plate and/or the sensor assembly part, in turn reducing the risk of terminal elements penetrating or otherwise damaging the first adhesive layer. The first intermediate element may protect or mechanically and/or electrically shield the first adhesive layer from the terminal elements of the base plate and/or the sensor assembly part.

The base plate may comprise a coupling ring or other coupling member for coupling an ostomy pouch to the base plate (two-part ostomy appliance). The center point may be defined as a center of the coupling ring.

The base plate and/or the sensor assembly part may have a stomal opening with a center point. The stomal opening of the base plate and/or the sensor assembly part may be formed collectively of stomal opening(s) of the layers of the base plate and/or the sensor assembly part, such as of the top layer, the first adhesive layer, the second layer and/or the sensor assembly part. The stomal opening(s) of the layers of the base plate and/or the sensor assembly part, such as of the top layer, the first adhesive layer, the second layer and/or the sensor assembly part may be aligned to form the stomal opening of the base plate and/or the sensor assembly part. The stomal opening may be a through-going passage of the base plate and/or the sensor assembly part. The stomal opening may be arranged substantially in the center of the base plate and/or the sensor assembly part. The stomal

opening(s) of the layers of the base plate and/or the sensor assembly part may be arranged substantially in the center of the respective layer. The stomal opening may be configured to receive a stoma of the user and/or the stomal opening may be configured to allow output from the stoma to pass through the stomal opening into an ostomy pouch attached to the base plate. For example, the stomal opening may be configured to allow passage of output from a proximal side of the base plate and/or sensor assembly part to a distal side of the base plate and/or sensor assembly part. The size and/or shape of the stomal opening may typically be adjusted by the user or nurse before application of the ostomy appliance to accommodate the user's stoma. In one or more exemplary base plates, the user forms the stomal opening during preparation of the base plate for application.

The monitor device comprises a processor and one or more interfaces, such as a first interface and/or a second interface. The monitor device may comprise a memory for storing ostomy data.

In one or more exemplary monitor devices, the processor is configured to apply a processing scheme, the first interface is connected to the processor and the memory, and the first interface is configured for collecting ostomy data from the base plate and/or the sensor assembly part coupled to the first interface. The ostomy data may comprise one or more, such as all, of first ostomy data from a first electrode pair of the base plate and/or the sensor assembly part, second ostomy data from a second electrode pair of the base plate and/or the sensor assembly part, and third ostomy data from a third electrode pair of the base plate and/or the sensor assembly part. A second interface is connected to the processor. To apply a processing scheme may comprise one or more of obtain first parameter data based on the first ostomy data; obtain second parameter data based on the second ostomy data; and obtain third parameter data based on the third ostomy data. To apply a processing scheme may comprise determining an operating state of the base plate and/or the sensor assembly part of the ostomy appliance based on one or more, such as all, of the first parameter data, the second parameter data and the third parameter data. The operating state may be indicative of a degree of radial erosion of the base plate and/or the sensor assembly part, such as of the first adhesive layer, and/or an acute leakage risk for the ostomy appliance. The monitor device is configured to, in accordance with a determination that the operating state is a first operating state, transmit a first monitor signal comprising monitor data indicative of the first operating state of the base plate and/or the sensor assembly part via the second interface; and/or in accordance with a determination that the operating state is a second operating state, transmit a second monitor signal comprising monitor data indicative of the second operating state of the base plate and/or the sensor assembly part via the second interface.

In one or more exemplary monitor devices, the first operating state of the base plate and/or the sensor assembly part corresponds to a situation wherein the first adhesive layer of the base plate and/or the sensor assembly part has experienced a first degree of radial erosion, e.g. the first adhesive layer is eroded to a first radial distance of the first electrode pair but not to a second radial distance of the second electrode pair.

In one or more exemplary monitor devices, the second operating state of the base plate and/or the sensor assembly part corresponds to a situation wherein the first adhesive layer of the base plate and/or the sensor assembly part has experienced a second degree of radial erosion, e.g. the first

11

adhesive layer is eroded to the second radial distance of the second electrode pair but not to a third radial distance of the third electrode pair.

To obtain first parameter data based on the first ostomy data may comprise determining one or more first parameters based on the first ostomy data. To obtain second parameter data based on the second ostomy data may comprise determining one or more second parameters based on the second ostomy data. To obtain third parameter data based on the third ostomy data may comprise determining one or more third parameters based on the third ostomy data. In one or more exemplary monitor devices, determination of an operating state may be based on one or more first parameters, such as first primary parameter and/or first secondary parameter of first parameter data. In one or more exemplary monitor devices, determination of an operating state may be based on one or more second parameters, such as second primary parameter and/or second secondary parameter of the second parameter data. In one or more exemplary monitor devices, determination of an operating state may be based on one or more third parameters, such as third primary parameter and/or third secondary parameter of the third parameter data.

In one or more exemplary monitor devices, determination of an operating state may be based on one or more fourth parameters, such as fourth primary parameter and/or fourth secondary parameter of the fourth parameter data.

The first parameter data, the second parameter data, and the third parameter data may be indicative of resistance between the first electrode pair, the second electrode pair, and the third electrode pair, respectively.

The first parameter data, the second parameter data, and the third parameter data may be indicative of a rate of change in resistance between the first electrode pair, the second electrode pair, and the third electrode pair, respectively.

In one or more exemplary monitor devices, to determine an operating state of the base plate and/or the sensor assembly part is based on a first criteria set based on the first parameter data and/or the second parameter data, wherein the operating state is determined to be the first operating state if the first criteria set is satisfied. The first criteria set may comprise one or more first criteria based on one or more of first parameter data, second parameter data and third parameter data. The first criteria set may comprise a first primary criterion based on the first parameter data. The first criteria set may comprise a first secondary criterion based on the second parameter data. The first criteria set may comprise a first tertiary criterion based on the third parameter data.

In one or more exemplary monitor devices, to determine an operating state of the base plate and/or the sensor assembly part may be based on a first threshold set comprising one or a plurality of first threshold values. The first threshold set may comprise one or a plurality of threshold values, e.g. to be applied in the first criteria set. The first threshold set may comprise a first primary threshold value. The first threshold set may comprise a first secondary threshold value. The first threshold set may comprise a first tertiary threshold value.

The first criteria set may be given by

$$(P_{1_1} < TH_{1_1}), \\ (P_{2_1} > TH_{1_2}), \text{ and} \\ (P_{3_1} > TH_{1_3}),$$

wherein P_{1_1} is a first primary parameter based on the first parameter data, TH_{1_1} is a first primary threshold value, P_{2_1} is a second primary parameter based on the

12

second parameter data, TH_{1_2} is a first secondary threshold value, P_{3_1} is a third primary parameter based on the third parameter data, and TH_{1_3} is a first tertiary threshold value, and wherein the first operating state is indicative of low degree of radial erosion on the base plate and/or the sensor assembly part. The first threshold values (TH_{1_1} , TH_{1_2} and TH_{1_3}) may be the same or different, e.g. depending on the electrode configuration of the base plate and/or the sensor assembly part. The first tertiary criterion ($P_{3_1} < TH_{1_3}$) may be omitted in the first criteria set.

The first primary parameter P_{1_1} may be indicative of the resistance between the first electrode pair (first electrode and first electrode part of the ground electrode) of the base plate and/or the sensor assembly part.

The second primary parameter may be indicative of the resistance between the second electrode pair (second electrode and second electrode part of the ground electrode) of the base plate and/or the sensor assembly part.

The third primary parameter may be indicative of resistance between the third electrode pair (third electrode and third electrode part of the ground electrode) of the base plate and/or the sensor assembly part.

In one or more exemplary monitor devices, to determine an operating state of the base plate and/or the sensor assembly part is based on a second criteria set based on the second parameter data and/or the third parameter data, wherein the operating state is determined to be the second operating state if the second criteria set is satisfied. The second criteria set may be based on the first parameter data.

The second criteria set may comprise one or more second criteria based on one or more of first parameter data, second parameter data and third parameter data. The second criteria set may comprise a second primary criterion based on the first parameter data. The second criteria set may comprise a second secondary criterion based on the second parameter data. The second criteria set may comprise a second tertiary criterion based on the third parameter data.

In one or more exemplary monitor devices, to determine an operating state of the base plate and/or the sensor assembly part is based on a second threshold set comprising one or a plurality of second threshold values. The second threshold set may comprise one or a plurality of threshold values, e.g. to be applied in the second criteria set. The second threshold set may comprise a second primary threshold value. The second threshold set may comprise a second secondary threshold value. The second threshold set may comprise a second tertiary threshold value.

The second criteria set may be given by

$$(P_{1_1} < TH_{2_1}), \\ (P_{2_1} < TH_{2_2}), \text{ and} \\ (P_{3_1} > TH_{2_3})$$

wherein P_{1_1} is a first primary parameter based on the first parameter data and indicative of the resistance between the first electrode pair, TH_{2_1} is a second primary threshold value, P_{2_1} is a second primary parameter based on the second parameter data and indicative of the resistance between the second electrode pair, TH_{2_2} is a second secondary threshold value, P_{3_1} is a third primary parameter based on the third parameter data and indicative of the resistance between the third electrode pair, TH_{2_3} is a second tertiary threshold value, and wherein the second operating state is indicative of medium degree of radial erosion on the base plate and/or the sensor assembly part. The second threshold values (TH_{2_1} , TH_{2_2} and TH_{2_3}) may be the same or different, e.g. depending on the electrode configuration of the base plate and/or the sensor assembly part. The second primary criterion

13

($P_{1_1} < TH_{2_1}$) and/or the second tertiary criterion ($P_{3_1} > TH_{2_3}$) may be omitted in the second criteria set.

In one or more exemplary monitor devices, to determine an operating state of the base plate and/or the sensor assembly part is based on a default criteria set based on the first parameter data, wherein the operating state is determined to be the default operating state if the default criteria set is satisfied, and in accordance with a determination that the operating state is the default operating state, transmit a default monitor signal comprising monitor data indicative of the default operating state of the ostomy appliance.

The default criteria set may be given by

($P_{1_1} > TH_{D_1}$),
($P_{2_1} > TH_{D_2}$), and
($P_{3_1} > TH_{D_3}$)

wherein P_{1_1} is a first primary parameter based on the first parameter data and indicative of the resistance between the first electrode pair, TH_{D_1} is a default primary threshold value, P_{2_1} is a second primary parameter based on the second parameter data and indicative of the resistance between the second electrode pair, TH_{D_2} is a default secondary threshold value, P_{3_1} is a third primary parameter based on the third parameter data and indicative of the resistance between the third electrode pair, TH_{D_3} is a default tertiary threshold value, and wherein the default operating state is indicative of very low or no degree of radial erosion on the base plate and/or the sensor assembly part. The default threshold values (TH_{D_1} , TH_{D_2} and TH_{D_3}) may be the same or different, e.g. depending on the electrode configuration of the base plate and/or the sensor assembly part.

In one or more exemplary monitor devices, to determine an operating state of the base plate and/or the sensor assembly part is based on a third criteria set based on the third parameter data, wherein the operating state is determined to be the third operating state if the third criteria set is satisfied, and in accordance with a determination that the operating state is the third operating state, transmit a third monitor signal comprising monitor data indicative of the third operating state of the ostomy appliance.

In one or more exemplary monitor devices, the third operating state of the base plate and/or the sensor assembly part corresponds to a situation wherein the first adhesive layer of the base plate and/or the sensor assembly part has experienced a third degree of radial erosion, e.g. the first adhesive layer is eroded to the third radial distance of the third electrode pair. The third criteria set may be given by

($P_{1_1} < TH_{3_1}$),
($P_{2_1} < TH_{3_2}$), and
($P_{3_1} < TH_{3_3}$)

wherein P_{1_1} is a first primary parameter based on the first parameter data and indicative of the resistance between the first electrode pair, TH_{3_1} is a third primary threshold value, P_{2_1} is a second primary parameter based on the second parameter data and indicative of the resistance between the second electrode pair, TH_{3_2} is a third secondary threshold value, P_{3_1} is a third primary parameter based on the third parameter data and indicative of the resistance between the third electrode pair, TH_{3_3} is a third tertiary threshold value, and wherein the third operating state is indicative of high degree of radial erosion on the base plate and/or the sensor assembly part. The third threshold values (TH_{3_1} , TH_{3_2} and TH_{3_3}) may be the same or different, e.g. depending on the electrode configuration of the base plate and/or the sensor assembly part. The third

14

primary criterion ($P_{1_1} < TH_{3_1}$) and/or the third secondary criterion ($P_{2_1} < TH_{3_2}$) may be omitted in the third criteria set.

In one or more exemplary monitor devices, the ostomy data comprises fourth ostomy data from a fourth electrode pair of the base plate and/or the sensor assembly part. To apply a processing scheme may comprise to obtain fourth parameter data based on the fourth ostomy data, and determine an operating state of the base plate and/or the sensor assembly part of the ostomy appliance based on the fourth parameter data. The monitor device may be configured to, in accordance with a determination that the operating state is a fourth operating state, transmit a fourth monitor signal comprising monitor data indicative of the fourth operating state of the ostomy appliance.

In one or more exemplary monitor devices, the fourth operating state of the base plate and/or the sensor assembly part corresponds to a situation, wherein the fourth electrode pair detects fluid, such as output, between the distal surface of first adhesive layer and the skin of the user at a fourth radial distance, and thus there is a high risk of leakage from the ostomy appliance in the fourth operating state.

The fourth criteria set may be given by

($P_{4_1} < TH_{4_4}$)

wherein P_{4_1} is a fourth primary parameter based on the fourth parameter data and indicative of the resistance between the fourth electrode pair and TH_{4_4} is a fourth quaternary threshold value, and wherein the fourth operating state is indicative of high risk of leakage from the ostomy appliance.

The monitor device comprises a monitor device housing optionally made of a plastic material. The monitor device housing may be an elongate housing having a first end and a second end. The monitor device housing may have a length or maximum extension along a longitudinal axis in the range from 1 cm to 15 cm. The monitor device housing may have a width or maximum extension perpendicular to the longitudinal axis in the range from 0.5 cm to 3 cm. The monitor device housing may be curve-shaped. Additionally or alternatively, the monitor device housing may be rigid or flexible.

The monitor device comprises a first interface. The first interface may be configured as an appliance interface for electrically and/or mechanically connecting the monitor device to the ostomy appliance. Thus, the appliance interface is configured to electrically and/or mechanically couple the monitor device and the ostomy appliance. The first interface may be configured as an accessory device interface for electrically and/or mechanically connecting the monitor device to an accessory device, such as a docking station. The first interface may be configured for coupling to a docking station of the ostomy system, e.g. for charging the monitor device and/or for data transfer between the monitor device and the docking station.

The first interface of the monitor device may comprise a plurality of terminals, such as two, three, four, five, six, seven or more terminals, for forming electrical connections with respective terminals and/or electrodes of the ostomy appliance. One or more terminals of the first interface may be configured for forming electrical connections with an accessory device, e.g. with respective terminals of a docking station. The first interface may comprise a ground terminal. The first interface may comprise a first terminal, a second terminal and optionally a third terminal. The first interface may comprise a fourth terminal and/or a fifth terminal. The first interface optionally comprises a sixth terminal. In one

15

or more exemplary monitor devices, the first interface has M terminals, wherein M is an integer in the range from 4 to 8.

The first interface of the monitor device may comprise a coupling part for forming a mechanical connection, such as a releasable coupling between the monitor device and the base plate and/or the sensor assembly part. The coupling part and the terminals of the first interface form (at least part of) a first connector of the monitor device.

The monitor device comprises a power unit for powering the monitor device. The power unit may comprise a battery. The power unit may comprise charging circuitry connected to the battery and terminals of the first interface for charging the battery via the first interface, e.g. the first connector. The first interface may comprise separate charging terminal(s) for charging the battery. Additionally or alternatively, the sensor terminal may change its function if the charging voltage is sensed at relevant terminals.

The monitor device may comprise a sensor unit with one or more sensor. The sensor unit is connected to the processor for feeding sensor data to the processor. The sensor unit may comprise an accelerometer for sensing acceleration and provision of acceleration data to the processor. The sensor unit may comprise a temperature sensor for provision of temperature data to the processor.

The monitor device comprises a second interface connected to the processor. The second interface may be configured as an accessory interface for connecting, e.g. wirelessly connecting, the monitor device to one or more accessory devices. The second interface may comprise an antenna and a wireless transceiver, e.g. configured for wireless communication at frequencies in the range from 2.4 to 2.5 GHz. The wireless transceiver may be a BLUETOOTH transceiver, i.e. the wireless transceiver may be configured for wireless communication according to BLUETOOTH protocol, e.g. BLUETOOTH Low Energy, BLUETOOTH 4.0, BLUETOOTH 5. The second interface optionally comprises a loudspeaker and/or a haptic feedback element for provision of an audio signal and/or haptic feedback to the user, respectively.

The monitor device may be electrically coupled to the plurality of electrodes of the base plate and/or the sensor assembly part. For example, the monitor device may be coupleable, such as releasably coupleable, to the plurality of electrodes of the base plate and/or the sensor assembly part. The monitor device may be configured to measure one or more resistances between the plurality of electrodes, and detect the leakage of output based on the measured one or more resistances.

In one or more exemplary ostomy systems, the monitor device forms an integrated part of the ostomy appliance, e.g. the monitor device may form an integrated part of a base plate and/or the sensor assembly part of the ostomy appliance.

The ostomy system may comprise a docking station forming an accessory device of the ostomy system. The docking station may be configured to electrically and/or mechanically couple the monitor device to the docking station.

The docking station may comprise a docking monitor interface. The docking monitor interface may be configured for electrically and/or mechanically connecting the monitor device to the docking station. The docking monitor interface may be configured for wirelessly connecting the monitor device to the docking station. The docking monitor interface of the docking station may be configured to electrically and/or mechanically couple the docking station and the monitor device.

16

The docking monitor interface of the docking station may comprise, e.g. as part of a first connector of the docking monitor interface, a coupling part for forming a mechanical connection, such as a releasable coupling between the monitor device and the docking station. The coupling part may be configured to engage with a coupling part of the monitor device for releasably coupling the monitor device to the docking station.

The docking monitor interface of the docking station may comprise, e.g. as part of a first connector of the docking monitor interface, a plurality of terminals, such as two, three, four, five, six, seven or more terminals, for forming electrical connections with respective terminals of the monitor device. The docking monitor interface may comprise a ground terminal. The docking monitor interface may comprise a first terminal and/or a second terminal. The docking station may comprise a third terminal. The docking monitor interface may comprise a fourth terminal and/or a fifth terminal. The docking monitor interface optionally comprises a sixth terminal.

Disclosed is a base plate and/or a sensor assembly part of an ostomy appliance. The base plate and/or the sensor assembly part comprises a first adhesive layer including: a stomal opening with a center point and a proximal surface configured to be attached to a skin surface of a user. In embodiments, the base plate and/or the sensor assembly part may comprise a masking element arranged on a distal surface of the first adhesive layer, wherein the masking element may be more insulative, such as less electrically conductive and/or less moisture-permeable, than the first adhesive layer. Additionally or alternatively, the base plate and/or the sensor assembly part may comprise a plurality of electrodes arranged on a distal side of the first adhesive layer, wherein each electrode includes a sensing part and a conductor part, wherein the masking element may be arranged between the conductor parts and the first adhesive layer.

In embodiments, the sensing parts of each electrode may facilitate determining a leak between a skin surface of the user and the base plate and/or the sensor assembly part, and/or the state of the adhesive device. Additionally or alternatively, by including a masking element arranged between the conductor parts and the first adhesive layer, the conductor parts of the electrodes may be insulated from the first adhesive layer, which may prevent more than one of the conductor parts of the electrodes from shorting together due to moisture absorption of the first adhesive layer.

The plurality of electrodes may be formed on a proximal surface of a support layer. The support layer may increase the structural integrity of the electrodes to, perhaps, reduce the likelihood the electrodes are damaged and/or broken.

The plurality of electrodes may be printed on the support layer.

The plurality of electrodes may form a first resistive pair of electrodes and a second resistive pair of electrodes, wherein each resistive pair of electrodes may include an electrode part of a ground electrode. The first and second resistive pairs of the electrodes may facilitate determining the adhesion between the base plate and/or the sensor assembly part and the skin surface of a user. By determining the adhesion between the base plate and/or the sensor assembly part and the skin surface of a user, the user may be alerted if the adhesion is deteriorating.

The moisture content of a respective sensing zone may be indicative of how well the first adhesive layer is adhering to the skin surface of a user. To determine the moisture content of a respective sensing zone, a resistance between the

electrodes included in the first, second, and/or third resistive pairs may be sensed by, for example, the monitor device. And, when the resistance between the electrodes included in the first, second, and/or third resistive pairs decreases below a threshold level, the monitor device may send an indication to the user that the adhesion between the first adhesive layer and the skin surface of a user may be deteriorating. In embodiments, when the adhesion between the first adhesive layer and the skin surface of a user proximal to the third resistive pair deteriorates, the monitor device may send a signal to the user suggesting the user change his/her ostomy appliance and/or base plate. Additionally or alternatively, when the adhesion between the first adhesive layer and the skin surface of a user proximal to the first resistive pair and/or second resistive pair deteriorates, the monitor device may send a signal to the user suggesting the user change his/her ostomy appliance and/or base plate.

In embodiments, the second resistive pair of electrodes may at least partially surround the first resistive pair of electrodes. By including a second resistive pair that at least partially surrounds a first resistive pair, a velocity of the deterioration of adhesion between the base plate and/or the sensor assembly part and the skin surface of a user may be determined.

The plurality of electrodes may form a third resistive pair of electrodes, wherein the third resistive pair of electrodes includes an electrode part of a ground electrode.

The third resistive pair of electrodes may at least partially surround the second resistive pair of electrodes. By including a third resistive pair that at least partially surrounds the second resistive pair of electrodes, and determining a velocity of adhesion deterioration based on the first and second resistive pairs, a prediction may be made as to when the adhesion between the skin surface of a user and the base plate and/or the sensor assembly part proximal to the third resistive pair may deteriorate.

By including different resistive pairs which at least partially surround one another, a monitor device may determine how quickly the adhesion between the first adhesive layer and the skin surface of a user may be deteriorating. For example, a monitor device may determine that at time t_1 the adhesion between the first adhesive layer and the skin surface of a user proximal to the first resistive pair is deteriorating by sensing a reduced resistance between the electrodes included in the first resistive pair. Then, at time t_2 the monitor device may determine the adhesion between the first adhesive layer and the skin surface of a user proximal to the second resistive pair is deteriorating by sensing a reduced resistance between the electrodes included in the second resistive pair. By knowing the distance between the first and second resistive pairs, the monitor device may calculate a velocity by dividing the distance between the first and second resistive pairs by the difference between t_1 and t_2 . The computed velocity may then determine how much time a user has before the adhesion between the first adhesive layer and the skin surface of a user proximal to the third resistive pair deteriorates, which may be when the user would like to change his/her ostomy appliance and/or base plate.

In embodiments, at least one of the first resistive pair, the second resistive pair, and the third resistive pair may be arranged circumferentially around the center point the stomal opening of the base plate and/or the sensor assembly part.

The base plate and/or the sensor assembly part may comprise a first intermediate element. The first intermediate element may be less compliant than the first adhesive layer,

e.g. the first intermediate element may be more rigid than the first adhesive layer. Each electrode may include a connection part, and the first intermediate element may be arranged between the connection parts and the first adhesive layer. By including the first intermediate element, the connection parts of the electrodes may be less likely to be damaged and/or broken.

In embodiments, the first intermediate element may facilitate protecting the terminal elements and/or the connection parts. For example, the first intermediate element may be less compliant than the first adhesive layer, the second adhesive layer, and/or the masking element. By being less compliant, the first intermediate element may reduce the ability of the terminal elements and/or the connection parts to flex. As such, the terminal elements and/or the connection parts may be less likely to break due to flexure. In embodiments, the first intermediate element may comprise at least one of polymeric (e.g. polyurethane, PTFE, PVDF) and ceramic (e.g. alumina, silica) materials.

Additionally or alternatively, the first intermediate element may reduce the likelihood that more than one of the terminal elements are shorted together and/or more than one of the connection parts are shorted together. For example, the first intermediate element may be less moisture absorbent than the first adhesive layer and/or the masking element. By being less moisture absorbent, the first intermediate element may prevent moisture (e.g., sweat, output, etc.) from coming into contact with one or more of the terminal elements and/or the connection parts via the first adhesive layer and/or the masking element and, potentially, shorting a combination of the terminal elements together and/or a combination of the connection parts together.

In embodiments, each electrode may include a connection part, wherein the masking element may comprise a plurality of terminal openings, and wherein each terminal opening may overlap a connection part.

In embodiments, wherein the first adhesive layer comprises a plurality of openings, wherein the masking element comprises a plurality of openings, and wherein each opening of the plurality of openings of the first adhesive layer overlaps an opening of the plurality of openings of the masking element, a sensor point is defined. In embodiments, the sensor points may be used to detect a leakage between a skin surface of a user and the base plate and/or the sensor assembly part.

In embodiments, the sensor points may be arranged at generally equal distances from the center point.

The base plate and/or the sensor assembly part may further comprise a second adhesive layer arranged distally of the plurality of electrodes. The second adhesive layer may protect the electrodes and/or add structural integrity to the base plate and/or the sensor assembly part.

In embodiments, the first adhesive layer and the second adhesive layer may be comprised of different ratios of one or more of: polyisobutenes, styrene-isoprene-styrene, and/or hydrocolloids. By being comprised of different ratios of materials, the second adhesive layer may provide a stronger attachment to the skin compared to attachment to the skin provided by the first adhesive layer and/or the first adhesive layer may provide less irritation to the skin surface of a user.

FIG. 1 illustrates an exemplary ostomy system. The ostomy system 1 comprises an ostomy appliance 2 including a base plate 4. The base plate 4 is adapted to support an ostomy pouch (not shown). Further, the ostomy system 1 comprises a monitor device 6 and an accessory device 8 (mobile telephone). The monitor device 6 is connectable to the base plate 4 via respective first connectors of the monitor

device 6 and base plate 4. The monitor device 6 is configured for wireless communication with the accessory device 8. Optionally, the accessory device 8 is configured to communicate with a server device 10 of the ostomy system 1, e.g. via network 12. The server device 10 may be operated and/or controlled by the ostomy appliance manufacturer, the accessory device 8, and/or a service centre. Ostomy data or parameter data based on the ostomy data are obtained from electrodes/sensors of the ostomy appliance 2 with the monitor device 6. The monitor device 6 processes the ostomy data and/or parameter data based on the ostomy data. Based on the processed ostomy data, the monitor device 6 may determine what monitor data that are transmitted to the accessory device 8. In the illustrated ostomy system, the accessory device 8 is a mobile phone, however the accessory device 8 may be embodied as another handheld device, such as a tablet device, or a wearable, such as a watch or other wrist-worn electronic device. Accordingly, the monitor device 6 is configured to determine and transmit monitor data to the accessory device 8. The base plate 4 comprises a coupling member 14 in the form of a coupling ring 16 for coupling an ostomy pouch (not shown) to the base plate (two-part ostomy appliance). In alternative embodiments, the ostomy pouch may be formed together with the base plate (one-part ostomy appliance). The base plate has a stomal opening 18 with a center point. The size and/or shape of the stomal opening 18 is typically adjusted by the user or nurse before application of the ostomy appliance to accommodate the user's stoma.

The ostomy system 1 optionally comprises a docking station 20 forming an alternative/additional accessory device of the ostomy system 1. The docking station 20 comprises a docking monitor interface including a first connector 22 configured for electrically and/or mechanically connecting the monitor device 6 to the docking station 20. The docking monitor interface may be configured for wirelessly connecting the monitor device to the docking station. The docking station 20 comprises a user interface 24 for receiving user input and/or providing feedback to the user on the operational state of the docking station 20. The user interface 24 may comprise a touch-screen. The user interface 24 may comprise one or more physical buttons and/or one or more visual indicators, such as light emitting diodes,

FIG. 2 is a schematic block diagram of an exemplary monitor device. The monitor device 6 comprises a monitor device housing 100, a processor 101 and one or more interfaces, the one or more interfaces including a first interface 102 (appliance interface) and a second interface 104 (accessory interface). The monitor device 6 comprises a memory 106 for storing ostomy data and/or parameter data based on the ostomy data. The memory 106 is connected to the processor 101 and/or the first interface 102.

The first interface 102 is configured as an appliance interface for electrically and/or mechanically connecting the monitor device 6 to the ostomy appliance, e.g. ostomy appliance 2. The first interface 102 comprises a plurality of terminals for forming electrical connections with respective terminals of the ostomy appliance 2 (base plate 4). In embodiments, the first interface 102 comprises a ground terminal 108, a first terminal 110, a second terminal 112 and a third terminal 114. The first interface 102 may also comprise a fourth terminal 116 and a fifth terminal 118. The first interface 102 of the monitor device 6 comprises a coupling part 120 for forming a mechanical connection, such as a releasable coupling between the monitor device and the base plate. The coupling part 120 and the terminals

108, 110, 112, 114, 116, and 118 of the first interface 102 form (at least part of) a first connector of the monitor device 6.

The monitor device 6 comprises a power unit 121 for powering the monitor device and active components thereof, i.e. the power unit 121 is connected to the processor 101, the first interface 102, the second interface 104, and memory 106. The power unit comprises a battery and charging circuitry. The charging circuitry is connected to the battery and terminals of the first interface 102 for charging the battery via terminals of the first interface, e.g. terminals of the first connector.

The second interface 104 of monitor device is configured as an accessory interface for connecting the monitor device 6 to one or more accessory devices such as accessory device 8. The second interface 104 comprises an antenna 122 and a wireless transceiver 124 configured for wireless communication with accessory device(s). Optionally, the second interface 104 comprises a loudspeaker 126 and/or a haptic feedback element 128 for provision of respective audio signal and/or haptic feedback to the user.

The monitor device 6 optionally comprises a sensor unit 140 connected to the processor 101. For example, the sensor unit 140 may comprise a temperature sensor for feeding temperature data to the processor and/or a G-sensor or accelerometer for feeding acceleration data to the processor 101. Additionally or alternatively, the sensor unit 140 comprises a humidity sensor and/or an acoustic sensor. The sensor unit 140 may comprise alternative and/or additional sensors suitable and/or relevant to an ostomy system as described.

The processor 101 is configured to apply a processing scheme, and the first interface 102 is configured for collecting ostomy data from the base plate and/or the sensor assembly part coupled to the first interface, the ostomy data comprising first ostomy data from a first electrode pair of the base plate and/or the sensor assembly part, second ostomy data from a second electrode pair of the base plate and/or the sensor assembly part, and third ostomy data from a third electrode pair of the base plate and/or the sensor assembly part. The ostomy data may be stored in the memory 106 and/or processed in the processor 101 in order to obtain parameter data. The parameter data may be stored in the memory 106. The processor 101 is configured to apply a processing scheme, wherein to apply a processing scheme comprises obtain first parameter data based on the first ostomy data; obtain second parameter data based on the second ostomy data; obtain third parameter data based on the third ostomy data. In other words, the processor 101 is configured to obtain first, second and third parameter data based on respective first, second and third ostomy data. To apply a processing scheme comprises to determine an operating state of the base plate and/or the sensor assembly part of the ostomy appliance based on one or more, e.g. all, of the first parameter data, the second parameter data and the third parameter data, wherein the operating state is indicative of a degree of radial erosion of the base plate and/or the sensor assembly part and/or acute leakage risk for the ostomy appliance. The monitor device 6 is configured to, in accordance with a determination that the operating state is a first operating state, transmit a first monitor signal comprising monitor data indicative of the first operating state of the base plate and/or the sensor assembly part via the second interface; and in accordance with a determination that the operating state is a second operating state, transmit a second monitor signal comprising monitor data indicative of the

21

second operating state of the base plate and/or the sensor assembly part via the second interface.

FIG. 3 illustrates an exploded view of an exemplary base plate of an ostomy appliance. The base plate 4 comprises a first adhesive layer 200. In embodiments, the first adhesive layer 200 comprises a stomal opening 18A, which may form part of the stomal opening 18. As stated above, the stomal opening 18 (see FIG. 1) may be adjusted before application to accommodate the user's stoma, which includes adjusting the stomal opening 18A. During use, the stoma-receiving opening 18, including the stomal opening 18A, is arranged around a user's stoma and a proximal surface 200B of the first adhesive layer 200 adheres to the skin surface of the user in the peristomal area and/or to additional seals, such as sealing paste, sealing tape and/or sealing ring.

In embodiments, the base plate 4 comprises a second adhesive layer 202, also denoted rim adhesive layer. As illustrated, the second adhesive layer 202 may be arranged distally of the first adhesive layer 200. Additionally or alternatively, a portion of the distal surface 200A of the first adhesive layer 200, which is not covered by the electrode assembly 204, may adhere to a portion of the proximal surface 202B of the second adhesive layer 202. In embodiments, the second adhesive layer 202 may have a second radial extension that is larger than a first radial extension of the first adhesive layer 200 at least in a first angular range of the base plate 4.

The first adhesive layer 200 and/or second adhesive layer 202 may comprise one or more of polyisobutenes, styrene-isoprene-styrene, and/or hydrocolloids. Different ratio of contents may change properties of the first and/or second adhesive layers 200, 202. As such, the second adhesive layer 202 and the first adhesive layer 200 may have different properties due to different ratios of polyisobutenes, styrene-isoprene-styrene, and/or hydrocolloids. For example, the second adhesive layer 202 may provide a stronger attachment to the skin compared to attachment to the skin provided by the first adhesive layer 200. Additionally or alternatively, the first adhesive layer may provide less irritation to the skin surface of a user. In embodiments, the second adhesive layer 202 may be thinner than the first adhesive layer 200. Additionally or alternatively, the second adhesive layer 202 may be less water and/or sweat absorbing than the first adhesive layer 200. Additionally or alternatively, the second adhesive layer 202 may be less mouldable than the first adhesive layer 200. The second adhesive layer 202 may provide a second barrier against leakage.

Additionally or alternatively, the second adhesive layer 202 may be less mouldable than the first adhesive layer 200. The second adhesive layer 202 may provide a second barrier against leakage.

The base plate 4 comprises a plurality of electrodes arranged in an electrode assembly 204. The electrode assembly 204 is arranged between the first adhesive layer 200 and the second adhesive layer 202. For example, the electrode assembly 204 may be arranged on a distal side (e.g., the distal surface 200A) of the first adhesive layer 200 and a proximal side (e.g., the proximal surface 202B) of the second adhesive layer 202.

The base plate 4 comprises a release liner 206 that is peeled off by the user prior to applying the base plate 4 on the skin. The base plate 4 comprises a top layer 208 and a coupling ring 209 for coupling an ostomy pouch to the base plate 4. The top layer 208 is a protective layer protecting the second adhesive layer 202 from external strains and stress during use.

22

The base plate 4 comprises a monitor interface. The monitor interface is configured for electrically and/or mechanically connecting the ostomy appliance (base plate 4) to the monitor device. The monitor interface of the base plate 4 comprises a coupling part 210 for forming a mechanical connection, such as a releasable coupling between the monitor device and the base plate. The coupling part 210 is configured to engage with a coupling part of the monitor device for releasably coupling the monitor device to the base plate 4. Further, the monitor interface of the base plate 4 comprises a plurality of terminal elements respectively forming a plurality of terminals 212 for forming electrical connections with respective terminals of the monitor device. The coupling part 210 and the terminals 212 form a first connector 211 of the base plate 4. The base plate 4 comprises a first intermediate element 213 on the proximal side of the electrode assembly. The first intermediate element 213 is arranged between the terminal elements forming terminals 212 and the first adhesive layer (not shown). The first intermediate element 213 covers the terminal elements forming terminals 212 of the base plate 4 when seen in the axial direction and protects the first adhesive layer from mechanical stress from the terminal elements of the base plate.

As previously described, some parts of the illustrated base plate 4, may be provided as a separate assembly to be applied to an existing base plate, e.g. comprising one or more of the components as described, such as to provide a base plate like the base plate 4 as described. For example, a sensor assembly part 700 may be provided, e.g. comprising the electrode assembly 204, the first connector 211, the first intermediate element 213, the first adhesive layer 200 and the release liner 206. Additionally, the sensor assembly part 700 may also comprise the second adhesive layer 202 and/or the top layer 208. It may be envisioned that the user may provide a hole in layers of the base plate whereto the sensor assembly part 700 is to be applied, to allow for the first connector 211 of the sensor assembly part 700 to protrude through layers of the base plate whereto the sensor assembly part 700 is applied. Alternatively, the sensor assembly part 700 may be applied to the base plate such that the first connector 211 is positioned outside the periphery of the base plate.

FIG. 4 illustrates an exploded view of an exemplary electrode assembly 204 of a base plate and/or a sensor assembly part. The electrode assembly 204 comprises a support layer 214 with proximal surface 214B and electrodes 216 arranged on the proximal side of the support layer 214. The electrode assembly 204 includes a ground electrode, a first electrode, a second electrode, a third electrode, a fourth electrode, and a fifth electrode, wherein each electrode has a respective connection part for connecting the electrodes to respective terminal elements of the monitor interface.

In embodiments, the electrodes 216 are electrically conductive and comprise at least one of metallic (e.g. silver, copper, gold, titanium, aluminium, stainless steel), ceramic (e.g. ITO), polymeric (e.g. PEDOT, PANI, PPy), and carbonaceous (e.g. carbon black, carbon nanotube, carbon fibre, graphene, graphite) materials. Additionally or alternatively, the electrodes 216 may be formed using screen-printing, inkjet-printing, direct-ink-writing, pen-plotting, 3D-printing, fused-deposition-modelling, contact-transfer printing, spray painting, chemical vapour depositing, physical vapour depositing, atomic-layer-depositing, wire-bending, and or any other methods known to a person skilled in the art. In

23

embodiments, the electrodes **216** can require one of heat-curing, UV-curing, and oxygen-activation.

In embodiments, the support layer **214** may increase the structural integrity of the electrodes **216**. Additionally or alternatively, the support layer **214** may be moisture resistant or moisture transmissive. In embodiments, the support layer **214** may comprise at least one of polymeric (e.g. polyurethane, PTFE, PVDF) and ceramic (e.g. alumina, silica) materials.

Further, electrode assembly **204** comprises a masking element **218** with proximal surface **218B**. In embodiments, the masking element **218** may be arranged on the distal surface **200A** of the first adhesive layer **200** (see FIG. 3). Additionally or alternatively, the masking element **218** may be comprised of a material that is more insulative (e.g., less electrically conductive and/or less moisture-permeable) than the first adhesive layer **200**. In embodiments, the masking element **218** may comprise at least one of polymeric (e.g. polyurethane, PTFE, PVDF) and ceramic (e.g. alumina, silica) materials. In embodiments, the masking element **218** may cover or overlap with parts of the electrodes **216** when seen in the axial direction. As such, the masking layer **218** may at least partially insulate electrode parts of the electrodes **216** from the first adhesive layer of the base plate **200** and/or the sensor assembly part.

FIG. 5 is a proximal view of proximal surfaces of base plate and/or the sensor assembly part parts of the base plate **4** and/or the sensor assembly part **700** without the first adhesive layer **200** (illustrated in FIG. 3) and the release liner **206** (illustrated in FIG. 3). The base plate **4** comprises a first intermediate element **213** on the proximal side of the electrode assembly, i.e. between the electrode assembly **204** and the first adhesive layer. The first intermediate element **213** covers the terminal elements of the base plate **4** when seen in the axial direction and protects the first adhesive layer **200** from mechanical stress from the terminal elements of the base plate **4** and/or the sensor assembly part **700**.

In embodiments, the first intermediate element **213** may facilitate protecting the terminal elements **212** and/or the connection parts **222A**, **224A**, **226A**, **228A**, **230A**, **232A** (see FIG. 6). For example, the first intermediate element **213** may be less compliant than the first adhesive layer **200** (depicted in FIG. 3), the second adhesive layer **202**, and/or the masking element **218**. By being less compliant, the first intermediate element **213** may reduce the ability of the terminal elements **212** and/or the connection parts **222A**, **224A**, **226A**, **228A**, **230A**, **232A** to flex. As such, the terminal elements **212** and/or the connection parts **222A**, **224A**, **226A**, **228A**, **230A**, **232A** may be less likely to break due to flexure. In embodiments, the first intermediate element **213** may comprise at least one of polymeric (e.g. polyurethane, PTFE, PVDF) and ceramic (e.g. alumina, silica) materials.

Additionally or alternatively, the first intermediate element **213** may reduce the likelihood that more than one of the terminal elements **212** are shorted together and/or more than one of the connection parts **222A**, **224A**, **226A**, **228A**, **230A**, **232A** are shorted together. For example, the first intermediate element **213** may be less moisture absorbent than the first adhesive layer **200** (depicted in FIG. 3) and/or the masking element **218**. By being less moisture absorbent, the first intermediate element **213** may prevent moisture (e.g., sweat, output, etc.) from coming into contact with one or more of the terminal elements **212** and/or the connection parts **222A**, **224A**, **226A**, **228A**, **230A**, **232A** via the first adhesive layer **200** and/or the masking element **218** and, potentially, shorting a combination of the terminal elements

24

212 together and/or a combination of the connection parts **222A**, **224A**, **226A**, **228A**, **230A**, **232A** together.

FIG. 6 is a distal view of an exemplary electrode configuration **220** of electrodes **216** of the electrode assembly **204**. The electrode assembly **204**, such as the electrode configuration **220**, of the electrode assembly **204** comprises a ground electrode **222**, a first electrode **224**, a second electrode **226**, a third electrode **228**, a fourth electrode **230**, and a fifth electrode **232**. The ground electrode **222** comprises a ground connection part **222A**, and a ground sensing part **222B**. The first electrode **224** comprises a first connection part **224A**. The second electrode **226** comprises a second connection part **226A** and the third electrode **228** comprises a third connection part **228A**. The fourth electrode **230** comprises a fourth connection part **230A** and the fifth electrode **232** comprises a fifth connection part **232A**. In embodiments, the plurality of electrodes **216** may be coupled to the monitor device **6** via the connection parts **222A**, **224A**, **226A**, **228A**, **230A**, **232A**. In particular, the ground connection part **222A** may be connected to the ground terminal **108** via the ground terminal **282** (illustrated in FIG. 10), the first connection part **224A** may be connected to the first terminal **110** via the first terminal **284** (illustrated in FIG. 10), the second connection part **226A** may be connected to the second terminal **112** via the second terminal **286** (illustrated in FIG. 10), the third connection part **228A** may be connected to the third terminal **114** via the third terminal **288** (illustrated in FIG. 10), the fourth connection part **230A** may be connected to the fourth terminal **116** via the fourth terminal **290** (illustrated in FIG. 10), and the fifth connection part **232A** may be connected to the fifth terminal **116** via the fifth terminal **292** (illustrated in FIG. 10). In embodiments, the plurality of electrodes **216** may be coupled to the monitor device **6** via the connection parts **222A**, **224A**, **226A**, **228A**, **230A**, **232A**. As such, the monitor device **6** may measure one or more resistances of the plurality of electrodes **216** for various purposes as described below. The fourth electrode **230** comprises fourth sensing parts **230B** and the fifth electrode **232** comprises fifth sensing parts **232B**. In embodiments, parts of the fourth electrode **230** that are not the fourth connection part **230A** and/or the fourth sensing parts **230B** may be referred to herein as conductor parts of the fourth electrode **230**. Similarly, parts of the fifth electrode **232** that are not the fifth connection part **232A** and/or the fifth sensing parts **232B** may be referred to herein as conductor parts of the fifth electrode **232**. Additionally or alternatively, parts of the ground electrode **222** that are not part of: a resistive pair (e.g., the first, second, and/or third resistive pairs **224B**, **226B**, **228B** described in more detail below), the ground connection part **222A** and/or the ground sensing parts **222B** may be referred to herein as conductor parts of the ground electrode **222**.

In embodiments, the first intermediate element **213** (depicted in FIG. 5) may be arranged between the connection parts **222A**, **224A**, **226A**, **228A**, **230A**, **232A** and the first adhesive layer **200**. As stated above, by arranging the first intermediate element **213** (depicted in FIG. 5) between the first adhesive layer **200** and the connection parts **222A**, **224A**, **226A**, **228A**, **230A**, **232A**, the connection parts **222A**, **224A**, **226A**, **228A**, **230A**, **232A** may be insulated from the first adhesive layer **200**. The ground electrode **222** comprises a first electrode part **234** for forming a ground for the first electrode **224**. The ground electrode **222** comprises a second electrode part **236** for forming a ground for the second electrode **226**. The ground electrode **222** comprises a third electrode part **238** for forming a ground for the third

25

electrode 228. The ground electrode 222 comprises a fourth electrode part 240 for forming a ground for the fourth electrode 230 and the fifth electrode 232. The fourth electrode part 240 of the ground electrode 222 comprises ground sensing parts 222B.

In view of the foregoing, the first electrode 224 and the first electrode part 234 may form a first resistive pair 224B, the second electrode 226 and the second electrode part 236 may form a second resistive pair 226B, and the third electrode 228 and the third electrode part 238 may form a third resistive pair 228B. Each of the first, second, and third resistive pairs 224B, 226B, 228B may define respective sensing zones. Each sensing zone may indicate a moisture content of the respective sensing zone.

The moisture content of a respective sensing zone may be indicative of how well the first adhesive layer 200 (depicted in FIG. 3) is adhering to the skin surface of a user. To determine the moisture content of a respective sensing zone, a resistance between the electrodes included in the first, second, and/or third resistive pairs 224B, 226B, 228B may be sensed by, for example, the monitor device 6 (depicted in FIG. 1). And, when the resistance between the electrodes included in the first, second, and/or third resistive pairs 224B, 226B, 228B decreases below a threshold level, the monitor device 6 may send an indication to the user that the adhesion between the first adhesive layer 200 and the skin surface of a user proximal to the third resistive pair 228B deteriorates, the monitor device 6 may send a signal to the user suggesting the user to change his/her ostomy appliance 2 and/or base plate 4. Additionally or alternatively, when the adhesion between the first adhesive layer 200 and the skin surface of a user proximal to the first resistive pair 224B and/or second resistive pair 226B deteriorates, the monitor device 6 may send a signal to the user suggesting the user to change his/her ostomy appliance 2 and/or base plate 4.

As illustrated in FIG. 6, the second resistive pair 226B may at least partially surround the first resistive pair 224B. Additionally or alternatively, the third resistive pair 228B may at least partially surround the second resistive pair 226B. Furthermore, in embodiments, one or more of the first, second, and third resistive pairs 224B, 226B, 228B may be arranged circumferentially around the stomal opening 18 (depicted in FIG. 1) and/or around the center point of the stomal opening 18.

By including different resistive pair 224B, 226B, 228B which at least partially surround one another, a monitor device 6 may determine how quickly the adhesion between the first adhesive layer 200 and the skin surface of a user may be deteriorating. For example, a monitor device 6 may determine that at time t_1 the adhesion between the first adhesive layer 200 and the skin surface of a user proximal to the first resistive pair 224B is deteriorating by sensing a reduced resistance between the electrodes included in the first resistive pair 224B. Then, at time t_2 the monitor device 6 may determine the adhesion between the first adhesive layer 200 and the skin surface of a user proximal to the second resistive pair 226B is deteriorating by sensing a reduced resistance between the electrodes included in the second resistive pair 226B. By knowing the distance between the first and second resistive pairs 226A, 228B, the monitor device 6 may calculate a velocity by dividing the distance between the first and second resistive pairs 226A, 228B by the difference between t_1 and t_2 . The computed velocity may then determine how much time a user has

26

before the adhesion between the first adhesive layer 200 and the skin surface of a user proximal to the third resistive pair 228B deteriorates, which may be when the user would like to change his/her ostomy appliance 2 and/or base plate 4.

FIG. 7 is a distal view of an exemplary masking element 218. In embodiments, the masking layer 218 may be arranged between conductor parts of the ground electrode 222, conductor parts of the fourth electrode 230, and/or conductor parts of the fifth electrode 232. That is, as stated above, the conductor parts of the ground electrode 222 are parts of the ground electrode 222 that are not the ground connection part 222A and/or the ground sensing parts 222B. Similarly, the conductor parts of the fourth electrode 230 are parts of the fourth electrode 230 that are not the fourth connection part 230A and/or the fourth sensing parts 230B and the conductor parts of the fifth electrode 232 are parts of the fifth electrode 232 that are not the fifth connection part 232A and/or the fifth sensing parts 232B. Further, because the masking element 218 may be more insulative than the first adhesive layer 200, the conductor parts of the ground electrode, the fourth electrode, and the fifth electrode may be insulated from the first adhesive layer 200.

The masking element 218 optionally has a plurality of terminal openings. For example, the masking element 218 may include one, two, three, four, five, six, seven, etc. terminal openings. In embodiments, the plurality of terminal openings comprises a ground terminal opening 242, a first terminal opening 244, a second terminal opening 246, a third terminal opening 248, a fourth terminal opening 250, and a fifth terminal opening 252. The terminal openings 242, 244, 246, 248, 250, 252 of the masking element 218 are configured to overlap (that is, axially align) with respective connection parts 222A, 224A, 226A, 228A, 230A, 232A of the electrodes of the electrode assembly. For example, connection part 222A may overlap the first terminal opening 244, connection part 224A may overlap the second terminal opening 244, connection part 226A may overlap the third terminal opening 246, connection part 228A may overlap the fourth terminal opening 250, connection part 230A may overlap the fifth terminal opening 252, and connection part 232A may overlap the sixth terminal opening 252. While the masking element 218 depicts six terminal openings, in other embodiments, the masking element 218 may include more or fewer terminal openings.

The masking element 218 has a plurality of sensor point openings. The sensor point openings comprise primary sensor point openings shown within dotted line 254. Each primary sensor point opening is configured to overlap (that is, axially align with) a ground sensing part 222B of the ground electrode 222 and/or a fourth sensing part 230B of the fourth electrode 230 of the electrode configuration 220. More specifically, in embodiments, the primary sensor point openings shown within dotted line 254 comprise, in the illustrated exemplary masking element, five primary first sensor point openings 254A each configured to overlap a ground sensing part 222B of the ground electrode 222. In addition, the primary sensor point openings shown within dotted line 254 comprise, in the illustrated exemplary masking element, four primary second sensor point openings 254B each configured to overlap a fourth sensing part 230B of the fourth electrode 230. In embodiments, each of the primary sensor point openings shown within dotted line 254 may be equal distances from a center point of the stomal opening 18. Alternatively, one or more of the primary sensor point openings shown within dotted line 254 may be different distances from a center point of the stomal opening 18. While the illustrated embodiment depicts five primary first

sensor point openings **254A** in the dotted line **254**, in other embodiments, the masking element **218** includes more or fewer than five primary first sensor point openings **254A** in the dotted line **254**. Additionally or alternatively, while the illustrated embodiment depicts four primary second sensor point openings **254B** in the dotted line **254**, in other embodiments, the masking element **218** includes more or fewer than four primary second sensor point openings **254B** in the dotted line **254**.

Additionally or alternatively, the sensor point openings comprise secondary sensor point openings shown within dotted line **256**. Each second sensor point opening is configured to overlap a fourth sensing part **230B** of the fourth electrode **230** and/or a fifth sensing part **232B** of the fifth electrode **232** of the electrode configuration **220**. More specifically, in embodiments, the secondary sensor point openings shown within dotted line **256** comprise, in the illustrated exemplary masking element, five secondary first sensor point openings **256A** each configured to overlap a fifth sensing part **232B** of the fifth electrode **232**. In addition, the secondary sensor point openings shown within dotted line **256** comprise, in the illustrated exemplary masking element, four secondary second sensor point openings **256B** each configured to overlap a fourth sensing part **230B** of the fourth electrode **230**. In embodiments, each of the secondary sensor point openings shown within dotted line **256** may be equal distances from a center point of the stomal opening **18**. Alternatively, one or more of the secondary sensor point opening shown within dotted line **256** may be different distances from a center point of the stomal opening **18**. In embodiments, the secondary sensor point openings shown within dotted line **256** may be substantially the same distance from a center point of the stomal opening **18** as the primary sensor point openings shown within dotted line **254**. Alternatively, one or more of the secondary sensor point openings shown within dotted line **256** may be different distance(s) from a center point of the stomal opening **18** as one or more of the primary sensor point openings shown within dotted line **254**. While the illustrated embodiment depicts five secondary first sensor point openings **256A** in the dotted line **256**, in other embodiments, the masking element **218** includes more or fewer than five secondary first sensor point openings **256A** in the dotted line **256**. Additionally or alternatively, while the illustrated embodiment depicts four secondary second sensor point openings **256B** in the dotted line **256**, in other embodiments, the masking element **218** includes more or fewer than four secondary second sensor point openings **256B** in the dotted line **256**.

Additionally or alternatively, the sensor point openings comprise tertiary sensor point openings shown within dotted line **258**. Each tertiary sensor opening is configured to overlap a fifth sensing part **232B** of the fifth electrode **232** and/or a ground sensing part **222B** of the ground electrode **222** of the electrode configuration **220**. More specifically, in embodiments, the tertiary sensor point openings shown within dotted line **258** comprise, in the illustrated exemplary masking element, five tertiary first sensor point openings **258A** each configured to overlap a fifth sensing part **232B** of the fifth electrode **232**. In addition, the tertiary sensor point openings shown within dotted line **258** comprise, in the illustrated exemplary masking element, four tertiary second sensor point openings **258B** each configured to overlap a ground sensing part **222B** of the ground electrode **222**. In embodiments, each of the tertiary sensor point openings shown within dotted line **258** may be equal distances from a center point of the stomal opening **18**. Alternatively, one or more of the tertiary sensor point opening shown within

dotted line **258** may be different distances from a center point of the stomal opening **18**. In embodiments, the tertiary sensor point openings shown within dotted line **258** may be substantially the same distance from a center point of the stomal opening **18** as the primary sensor point openings shown within dotted line **254**. Alternatively, one or more of the tertiary sensor point openings shown within dotted line **258** may be different distance(s) from a center point of the stomal opening **18** as one or more of the primary sensor point openings shown within dotted line **254**. Additionally or alternatively, the tertiary sensor point openings shown within dotted line **258** may be substantially the same distance from a center point of the stomal opening **18** as the secondary sensor point openings shown within dotted line **256**. Alternatively, one or more of the tertiary sensor point openings shown within dotted line **258** may be different distance(s) from a center point of the stomal opening **18** as one or more of the secondary sensor point openings shown within dotted line **256**. While the illustrated embodiment depicts five tertiary first sensor point openings **258A** in the dotted line **258**, in other embodiments, the masking element **218** includes more or fewer than five tertiary first sensor point openings **258A** in the dotted line **258**. Additionally or alternatively, while the illustrated embodiment depicts four tertiary second sensor point openings **258B** in the dotted line **258**, in other embodiments, the masking element **218** includes more or fewer than four tertiary second sensor point openings **258B** in the dotted line **258**.

While the primary sensor point openings shown within dotted line **254**, secondary sensor point openings shown within dotted line **256**, and tertiary sensor point openings shown within dotted line **258** are evenly distributed angularly about the stomal opening **18**, in other embodiments, the primary sensor point openings shown within dotted line **254**, secondary sensor point openings shown within dotted line **256**, and tertiary sensor point openings shown within dotted line **258** may be unevenly distributed angularly about the stomal opening **18** and/or focused within an angular range about the stomal opening **18** (e.g., 30 degrees-330 degrees). However, these are only examples and not meant to be limiting. Additionally or alternatively, while the illustrated embodiment depicts three sectors of sensor point openings (i.e., the primary sensor point openings, the secondary sensor point openings, and the tertiary sensor point openings), in alternative embodiments, the masking element **218** may include more or fewer sectors of sensor points openings. Additionally or alternatively, each sector may be unevenly distributed about the center point of the stomal opening **18**, each sector may span different angular ranges, which may or may not be the same between the sectors, and/or may have different starting angles and/or different ending angles.

FIG. **8** is a distal view of an exemplary first adhesive layer **200** and FIG. **9** is a proximal view of the first adhesive layer of FIG. **8**. The first adhesive layer **200** has a plurality of sensor point openings. The sensor point openings of the first adhesive layer comprise primary sensor point openings shown within dotted line **260**. Each primary sensor point opening is configured to overlap a ground sensing part **222B** of the ground electrode **222** and/or a fourth sensing part **230B** of the fourth electrode **230** of the electrode configuration **220**. More specifically, in embodiments, the primary sensor point openings shown within dotted line **260** comprise, in the illustrated exemplary first adhesive layer **200**, five primary first sensor point openings **260A** each configured to overlap a ground sensing part **222B** of the ground electrode **222**. In addition, the primary sensor point openings

shown within dotted line 260 comprise, in the illustrated exemplary first adhesive layer 200, four primary second sensor point openings 260B each configured to overlap a fourth sensing part 230B of the fourth electrode 230. In embodiments, each of the primary sensor point openings shown within dotted line 260 may be equal distances from a center point of the stomal opening 18. Alternatively, one or more of the primary sensor point opening shown within dotted line 260 may be different distances from a center point of the stomal opening 18. While the illustrated embodiment depicts five primary first sensor point openings 260A in the dotted line 260, in other embodiments, the first adhesive layer 200 includes more or fewer than five primary first sensor point openings 260A in the dotted line 260. Additionally or alternatively, while the illustrated embodiment depicts four primary second sensor point openings 260B in the dotted line 260, in other embodiments, the first adhesive layer 200 includes more or fewer than four primary second sensor point openings 260B in the dotted line 260.

Additionally or alternatively, the sensor point openings of the first adhesive layer comprise secondary sensor point openings shown within dotted line 262. Each second sensor point opening is configured to overlap a fourth sensing part 230B of the fourth electrode 230 and/or a fifth sensing part 232B of the fifth electrode 232 of the electrode configuration 220. More specifically, in embodiments, the secondary sensor point openings shown within dotted line 262 comprise, in the illustrated exemplary first adhesive layer 200, five secondary first sensor point openings 262A each configured to overlap a fifth sensing part 232B of the fifth electrode 232. In addition, the secondary sensor point openings shown within dotted line 262 comprise, in the illustrated exemplary first adhesive layer 200, four secondary second sensor point openings 262B each configured to overlap a fourth sensing part 230B of the fourth electrode 230. In embodiments, each of the secondary sensor point openings shown within dotted line 262 may be equal distances from a center point of the stomal opening 18. Alternatively, one or more of the secondary sensor point opening shown within dotted line 262 may be different distance(s) from a center point of the stomal opening 18 as one or more of the primary sensor point openings shown within dotted line 260. While the illustrated embodiment depicts five secondary first sensor point openings 262A in the dotted line 262, in other embodiments, the first adhesive layer 200 includes more or fewer than five secondary first sensor point openings 262A in the dotted line 262. Additionally or alternatively, while the illustrated embodiment depicts four secondary second sensor point openings 262B in the dotted line 262, in other embodiments, the first adhesive layer 200 includes more or fewer than four secondary second sensor point openings 262B in the dotted line 262.

Additionally or alternatively, the sensor point openings of the first adhesive layer 200 comprise tertiary sensor point openings shown within dotted line 264. Each tertiary sensor opening is configured to overlap a fifth sensing part 232B of the fifth electrode 232 and/or a ground sensing part 222B of the ground electrode 222 of the electrode configuration 220. More specifically, in embodiments, the tertiary sensor point openings shown within dotted line 264 comprise, in the

illustrated exemplary first adhesive layer 200, five tertiary first sensor point openings 264A each configured to overlap a fifth sensing part 232B of the fifth electrode 232. In addition, the tertiary sensor point openings shown within dotted line 264 comprise, in the illustrated exemplary first adhesive layer 200, four tertiary second sensor point openings 264B each configured to overlap a ground sensing part 222B of the ground electrode 222. In embodiments, each of the tertiary sensor point openings shown within dotted line 264 may be equal distances from a center point of the stomal opening 18. Alternatively, one or more of the tertiary sensor point opening shown within dotted line 264 may be different distances from a center point of the stomal opening 18. In embodiments, the tertiary sensor point openings shown within dotted line 264 may be substantially the same distance from a center point of the stomal opening 18 as the primary sensor point openings shown within dotted line 260. Alternatively, one or more of the tertiary sensor point openings shown within dotted line 264 may be different distance(s) from a center point of the stomal opening 18 as one or more of the primary sensor point openings shown within dotted line 260. Additionally or alternatively, the tertiary sensor point openings shown within dotted line 264 may be substantially the same distance from a center point of the stomal opening 18 as the secondary sensor point openings shown within dotted line 262. Alternatively, one or more of the tertiary sensor point openings shown within dotted line 264 may be different distance(s) from a center point of the stomal opening 18 as one or more of the secondary sensor point openings shown within dotted line 262. While the illustrated embodiment depicts five tertiary first sensor point openings 264A in the dotted line 264, in other embodiments, the first adhesive layer 200 includes more or fewer than five tertiary first sensor point openings 264A in the dotted line 264. Additionally or alternatively, while the illustrated embodiment depicts four tertiary second sensor point openings 264B in the dotted line 264, in other embodiments, the first adhesive layer 200 includes more or fewer than four tertiary second sensor point openings 264B in the dotted line 264.

Additionally or alternatively, while the illustrated embodiment depicts three sectors of sensor point openings (i.e., the primary sensor point openings, the secondary sensor point openings, and the tertiary sensor point openings), in alternative embodiments, the first adhesive layer 200 may include more or fewer sectors of sensor points openings. Additionally or alternatively, each sector may be unevenly distributed about the center point of the stomal opening 18, each sector may span different angular ranges, which may or may not be the same between the sectors, and/or may have different starting angles and/or different ending angles.

In view of the foregoing, the primary sensor point openings shown within dotted line 254 of the masking element 218 (depicted in FIG. 7) may overlap the primary sensor point openings shown within dotted line 260 of the first adhesive layer 200. More specifically, each of the five primary first sensor point openings 254A may overlap a respective one of the five primary first sensor point openings 260A. As such, the ground sensor points 222B, which the five primary first sensor point openings 254A and the five primary first sensor point openings 260A overlap, may be exposed in an axial direction from the proximal surface 200B of the first adhesive layer 200. Furthermore, each of the four primary second sensor point openings 254B may overlap a respective one of the four primary second sensor point openings 260B. As such, the fourth sensor points

230B, which the four primary second sensor point openings 254B and the four primary second sensor point openings 260B overlap, may be exposed in an axial direction from the proximal surface 200B of the first adhesive layer 200. In 5 embodiments, when output spans or bridges from a ground sensor point 222B to a fourth sensor point 230B, a leak may be detected by, for example, the monitor device 6. More specifically, a drop in resistance may be sensed between a ground sensor point 222B and a fourth sensor point 230B by the monitor device 6 in response to output spanning and/or 10 bridging from a ground sensor point 222B to a fourth sensor point 230B.

Additionally or alternatively, the second sensor point openings shown within dotted line 256 of the masking element 218 (depicted in FIG. 7) may overlap the second 15 sensor point openings shown within dotted line 262 of the first adhesive layer 200. More specifically, each of the five secondary first sensor point openings 256A may overlap a respective one of the five secondary first sensor point openings 262A. As such, the fifth sensor points 232B, which the five secondary first sensor point openings 256A and the five secondary first sensor point openings 262A overlap, may be exposed in an axial direction from the proximal surface 200B of the first adhesive layer 200. Furthermore, each of the four secondary second sensor point openings 256B may overlap a respective one of the four secondary second sensor point openings 262B. As such, the fourth sensor points 230B, which the four secondary second sensor point openings 256B and the four secondary second sensor point openings 262B overlap, may be exposed in an axial direction from the proximal surface 200B of the first adhesive layer 200. In embodiments, when output spans or bridges from a fifth sensor point 232B to a fourth sensor point 230B, a leak may be detected by, for example, the monitor device 6. More specifically, a drop in resistance may be sensed between a fifth sensor point 232B and a fourth sensor point 230B by the monitor device 6 in response to output spanning and/or bridging from a fifth sensor point 232B to a fourth sensor point 230B.

Additionally or alternatively, the tertiary sensor point openings shown within dotted line 258 of the masking element 218 (depicted in FIG. 7) may overlap the tertiary sensor point openings shown within dotted line 264 of the first adhesive layer 200. More specifically, each of the five tertiary first sensor point openings 258A may overlap a 45 respective one of the five tertiary first sensor point openings 264A. As such, the ground sensor points 222B, which the five tertiary first sensor point openings 258A and the five tertiary first sensor point openings 264A overlap, may be exposed in an axial direction from the proximal surface 200B of the first adhesive layer 200. Furthermore, each of the four tertiary second sensor point openings 258B may overlap a respective one of the four tertiary second sensor point openings 264B. As such, the fifth sensor points 232B, which the four tertiary second sensor point openings 258B and the four tertiary second sensor point openings 264B overlap, may be exposed in an axial direction from the proximal surface 200B of the first adhesive layer 200. In 60 embodiments, when output spans or bridges from a ground sensor point 222B to a fifth sensor point 232B, a leak may be detected by, for example, the monitor device 6. More specifically, a drop in resistance may be sensed between a ground sensor point 222B and a fifth sensor point 232B by the monitor device 6 in response to output spanning and/or 65 bridging from a ground sensor point 222B to a fifth sensor point 232B.

FIG. 10 is a more detailed distal view of a part of the base plate 4 and/or the sensor assembly part 700. Monitor interface of the base plate and/or the sensor assembly part comprises the first connector 211. The first connector 211 5 comprises coupling part 210 configured to releasably couple the monitor device to the base plate and/or the sensor assembly part and thus forming a releasable coupling. The first connector 211/monitor interface comprises a plurality of terminals formed by respective terminal elements for 10 forming respective electrical connections with respective terminals of the monitor device.

In embodiments, the plurality of terminals of the first connector 211 of the monitor interface comprises a ground terminal element 282 forming a ground terminal 282A, a 15 first terminal element 284 forming a first terminal 284A, a second terminal element 286 forming a second terminal 286A, and a third terminal element 288 forming a third terminal 288A. The monitor interface optionally comprises a fourth terminal element 290 forming a fourth terminal 290A and/or a fifth terminal element 292 forming a fifth terminal 292A. The terminal elements 282, 284, 286, 288, 290, 292 contact respective connection parts 222A, 224A, 226A, 228A, 230a, 232A of electrodes 222, 224, 226, 228, 230, 232. The use of the terms “first”, “second”, “third” and 25 “fourth”, “primary”, “secondary”, “tertiary” etc. does not imply any particular order, but are included to identify individual elements. Moreover, the use of the terms “first”, “second”, “third” and “fourth”, “primary”, “secondary”, “tertiary” etc. does not denote any order or importance, but rather the terms “first”, “second”, “third” and “fourth”, “primary”, “secondary”, “tertiary” etc. are used to distinguish one element from another. Note that the words “first”, “second”, “third” and “fourth”, “primary”, “secondary”, “tertiary” etc. are used here and elsewhere for labelling 35 purposes only and are not intended to denote any specific spatial or temporal ordering. Furthermore, the labelling of a first element does not imply the presence of a second element and vice versa.

Although particular features have been shown and 40 described, it will be understood that they are not intended to limit the claimed invention, and it will be made obvious to those skilled in the art that various changes and modifications may be made without departing from the spirit and scope of the claimed invention. The specification and drawings are, accordingly to be regarded in an illustrative rather than restrictive sense. The claimed invention is intended to cover all alternatives, modifications and equivalents.

Embodiments of the present disclosure are set out in the following items:

1. A sensor assembly part of an ostomy appliance, the sensor assembly part comprising:
 - a first adhesive layer including: a stomal opening with a center point and a proximal surface configured to be attached to a skin surface of a user;
 - a masking element arranged on a distal surface of the first adhesive layer, wherein the masking element is more insulative than the first adhesive layer; and
 - a plurality of electrodes arranged on a distal side of the first adhesive layer, each electrode including a sensing part and a conductor part, wherein the masking element is arranged between the conductor parts and the first adhesive layer.
2. The sensor assembly part of item 1, the plurality of electrodes being formed on a proximal surface of a support layer.
3. The sensor assembly part of item 2, the plurality of electrodes being printed on the support layer.

4. The sensor assembly part of any of items 1-3, the plurality of electrodes forming a first resistive pair of electrodes and a second resistive pair of electrodes, wherein each resistive pair of electrodes includes an electrode part of a ground electrode.

5. The sensor assembly part of any of items 1-4, wherein the second resistive pair of electrodes at least partially surrounds the first resistive pair of electrodes.

6. The sensor assembly part of any of items 1-5 as dependent on item 4, the plurality of electrodes forming a third resistive pair of electrodes, wherein the third resistive pair of electrodes includes an electrode part of a ground electrode.

7. The sensor assembly part of any of items 1-6 as dependent on item 6, wherein the third resistive pair of electrodes at least partially surrounds the second resistive pair of electrodes.

8. The sensor assembly part of any of items 1-7 as dependent on item 6, wherein at least one of the first resistive pair, the second resistive pair, and the third resistive pair are arranged circumferentially around the center point.

9. The sensor assembly part of any of items 1-8, further comprising a first intermediate element, wherein the first intermediate element is less compliant than the first adhesive layer, wherein each electrode includes a connection part and wherein the first intermediate element is arranged between the connection parts and the first adhesive layer.

10. The sensor assembly part of any of items 1-9, wherein each electrode includes a connection part, wherein the masking element comprises a plurality of terminal openings, and wherein each terminal opening overlaps a connection part.

11. The sensor assembly part of any of items 1-10, wherein the first adhesive layer comprises a plurality of openings, wherein the masking element comprises a plurality of openings, and wherein each opening of the plurality of openings of the first adhesive layer overlaps an opening of the plurality of openings of the masking element for form a sensor point.

12. The sensor assembly part of any of items 1-11 as dependent on item 10, wherein the sensor points are arranged at generally equal distances from the center point.

13. The sensor assembly part of any of items 1-12, further comprising a second adhesive layer arranged distally of the plurality of electrodes.

14. The sensor assembly part of any of items 1-13 as dependent on item 13, wherein the first adhesive layer and the second adhesive layer are comprised of different ratios of one or more of: polyisobutenes, styrene-isoprene-styrene, and/or hydrocoloids.

LIST OF REFERENCES

1 ostomy system
 2 ostomy appliance
 4 base plate
 6 monitor device
 8 accessory device
 10 server device
 12 network
 14 coupling member
 16 coupling ring
 18 stomal opening
 20 docking station
 22 first connector
 24 user interface
 100 monitor device housing

101 processor
 102 first interface
 104 second interface
 106 memory
 5 108 ground terminal of monitor device
 110 first terminal of monitor device
 112 second terminal of monitor device
 114 third terminal of monitor device
 116 fourth terminal of monitor device
 10 118 fifth terminal of monitor device
 120 coupling part
 121 power unit
 122 antenna
 124 wireless transceiver
 15 126 loudspeaker
 128 haptic feedback element
 140 sensor unit
 200 first adhesive layer
 200A distal surface of first adhesive layer
 20 200B proximal surface of first adhesive layer
 202 second adhesive layer
 202A distal surface of second adhesive layer
 202B proximal surface of second adhesive layer
 204 electrode assembly
 25 206 release liner
 206A distal surface of the release liner
 208 top layer
 208A distal surface of the top layer
 209 coupling ring
 30 210 coupling part of first connector
 211 first connector
 212 terminals of first connector
 213 first intermediate element
 213A distal surface of first intermediate element
 35 213B proximal surface of first intermediate element
 214 support layer of electrode assembly
 214B proximal surface of support layer
 216 electrodes of electrode assembly
 218 masking element
 40 218A distal surface of masking element
 218B proximal surface of masking element
 220 electrode configuration
 222 ground electrode
 222A ground connection part
 45 222B ground sensing part
 224 first electrode
 224A first connection part
 224B first resistive pair
 226 second electrode
 50 226A second connection part
 226B second resistive pair
 228 third electrode
 228A third connection part
 228B third resistive pair
 55 230 fourth electrode
 230A fourth connection part
 230B fourth sensing part
 232 fifth electrode
 232A fifth connection part
 60 232B fifth sensing part
 234 first electrode part of the ground electrode
 236 second electrode part of the ground electrode
 238 third electrode part of the ground electrode
 240 fourth electrode part of the ground electrode
 65 242 ground terminal opening
 244 first terminal opening
 246 second terminal opening

248 third terminal opening
 250 fourth terminal opening
 252 fifth terminal opening
 254 primary sensor point openings of masking element
 254A primary first sensor point opening
 254B primary second sensor point opening
 256 secondary sensor point openings of masking element
 256A secondary first sensor point opening
 256B secondary second sensor point opening
 258 tertiary sensor point openings of masking element
 258A tertiary first sensor point opening
 258B tertiary second sensor point opening
 260 primary sensor point openings of first adhesive layer
 260A primary first sensor point opening
 260B primary second sensor point opening
 262 secondary sensor point openings of first adhesive layer
 262A secondary first sensor point opening
 262B secondary second sensor point opening
 264 tertiary sensor point openings of first adhesive layer
 264A tertiary first sensor point opening
 264B tertiary second sensor point opening
 282 ground terminal element
 282A ground terminal
 284 first terminal element
 284A first terminal
 286 second terminal element
 286A second terminal
 288 third terminal element
 288A third terminal
 290 fourth terminal element
 290A fourth terminal
 292 fifth terminal element
 292A fifth terminal
 700 sensor assembly part

The invention claimed is:

1. A base plate of an ostomy appliance, the base plate comprising:

a first adhesive layer including: a stomal opening with a center point and a proximal surface configured to be attached to a skin surface of a user;
 a masking element arranged on a distal surface of the first adhesive layer, wherein the masking element is more insulative than the first adhesive layer; and
 a plurality of electrodes arranged entirely between a proximal surface of a support layer and a distal side of the first adhesive layer, each electrode including a sensing part and a conductor part, wherein the masking element is arranged between the conductor parts of the plurality of electrodes and the first adhesive layer, and wherein the masking element is not arranged between the sensing parts of the plurality of electrodes and the first adhesive layer.

2. The base plate of claim 1, wherein the plurality of electrodes is printed on the support layer.

3. The base plate of claim 1, wherein the plurality of electrodes forms a first resistive pair of electrodes and a second resistive pair of electrodes, wherein each resistive pair of electrodes includes an electrode part of a ground electrode.

4. The base plate of claim 3, wherein the second resistive pair of electrodes at least partially surrounds the first resistive pair of electrodes.

5. The base plate of claim 3, wherein the plurality of electrodes forms a third resistive pair of electrodes, wherein the third resistive pair of electrodes includes an electrode part of a ground electrode.

6. The base plate of claim 5, wherein the third resistive pair of electrodes at least partially surrounds the second resistive pair of electrodes.

7. The base plate of claim 5, wherein at least one of the first resistive pair, the second resistive pair, and the third resistive pair is arranged circumferentially around the center point.

8. The base plate of claim 1, further comprising a first intermediate element, wherein the first intermediate element is less compliant than the first adhesive layer, wherein each electrode includes a connection part and wherein the first intermediate element is arranged between the connection parts and the first adhesive layer.

9. The base plate of claim 1, wherein each electrode includes a connection part, wherein the masking element comprises a plurality of terminal openings, and wherein each terminal opening overlaps a connection part.

10. The base plate of claim 1, wherein the first adhesive layer comprises a plurality of openings, wherein the masking element comprises a plurality of openings, and wherein each opening of the plurality of openings of the first adhesive layer overlaps an opening of the plurality of openings of the masking element to form a sensor point.

11. The base plate of claim 10, wherein the sensor points are arranged at generally equal distances from the center point.

12. The base plate of claim 1, further comprising a second adhesive layer arranged distally of the plurality of electrodes.

13. The base plate of claim 12, wherein the first adhesive layer and the second adhesive layer are comprised of different ratios of one or more of: polyisobutenes, styrene-isoprene-styrene, and/or hydrocolloids.

14. A base plate of an ostomy appliance, the base plate comprising:

a first adhesive layer including: a stomal opening with a center point and a proximal surface configured to be attached to a skin surface of a user;
 a masking element arranged on a distal surface of the first adhesive layer, wherein the masking element is more insulative than the first adhesive layer; and
 a plurality of electrodes arranged entirely between a proximal surface of a support layer and a distal side of the first adhesive layer in an axial direction, each electrode including a sensing part and a conductor part, wherein the masking element is arranged between the conductor parts of the plurality of electrodes and the first adhesive layer, and wherein the masking element is not arranged between the sensing parts of the plurality of electrodes and the first adhesive layer.

15. The base plate of claim 14, further comprising a first intermediate element, wherein the first intermediate element is less compliant than the first adhesive layer, wherein each electrode includes a connection part and wherein the first intermediate element is arranged between the connection parts and the first adhesive layer.

16. The base plate of claim 14, wherein each electrode includes a connection part, wherein the masking element comprises a plurality of terminal openings, and wherein each terminal opening overlaps a connection part.

17. The base plate of claim 14, wherein:
 the first adhesive layer comprises a plurality of openings;
 the masking element comprises a plurality of openings;
 and

each opening of the plurality of openings of the first adhesive layer overlaps an opening of the plurality of openings of the masking element to form a sensor point.

18. The base plate of claim **17**, wherein the sensor points are arranged at generally equal distances from the center point. 5

19. The base plate of claim **14**, further comprising a second adhesive layer arranged distally of the plurality of electrodes. 10

20. The base plate of claim **19**, wherein the first adhesive layer and the second adhesive layer are comprised of different ratios of one or more of: polyisobutenes, styrene-isoprene-styrene, and/or hydrocolloids. 15

* * * * *