



US011677478B2

(12) **United States Patent**
Nagarajan et al.

(10) **Patent No.:** **US 11,677,478 B2**
(45) **Date of Patent:** **Jun. 13, 2023**

(54) **METHOD FOR CO-PACKAGING LIGHT ENGINE CHIPLETS ON SWITCH SUBSTRATE**

(58) **Field of Classification Search**
CPC H04B 10/801
See application file for complete search history.

(71) Applicant: **MARVELL ASIA PTE, LTD.**,
Singapore (SG)

(56) **References Cited**

(72) Inventors: **Radhakrishnan L. Nagarajan**, Santa Clara, CA (US); **Liang Ding**, Singapore (SG); **Mark Patterson**, Santa Clara, CA (US); **Roberto Coccioli**, Santa Clara, CA (US); **Steve Aboagye**, Santa Clara, CA (US)

U.S. PATENT DOCUMENTS

6,219,241 B1 * 4/2001 Jones H05K 7/1007
439/342

7,329,054 B1 2/2008 Epitoux et al.
(Continued)

(73) Assignee: **MARVELL ASIA PTE LTD**,
Singapore (SG)

OTHER PUBLICATIONS

(*) Notice: Subject to any disclaimer, the term of this patent is extended or adjusted under 35 U.S.C. 154(b) by 0 days.

Janta-Polczynski et al., "Packaging challenges for next-generation high bandwidth optoelectrical switch modules", SPIE, Feb. 2020 (Year: 2020).*

(Continued)

(21) Appl. No.: **17/398,481**

Primary Examiner — Shi K Li

(22) Filed: **Aug. 10, 2021**

(65) **Prior Publication Data**

US 2021/0384989 A1 Dec. 9, 2021

Related U.S. Application Data

(63) Continuation of application No. 16/894,622, filed on Jun. 5, 2020, now Pat. No. 11,165,509.

(57) **ABSTRACT**

A co-packaged optical module includes a substrate, a processor arranged on the substrate and a plurality of light engines mounted around the processor on the substrate using mounting assemblies configured to attach the respective light engines to the substrate. The light engines and the mounting assemblies are disposed along a perimeter of the substrate, including at corners of the substrate. Each of the mounting assemblies includes a socket, a metal clamp clamping a corresponding one of the light engines into the socket, and a plurality of pins which when mated with corresponding holes in the substrate cause peripheries of the mounting assemblies, including the light engines, the sockets and the metal clamps, to be flush with the perimeter of the substrate.

(51) **Int. Cl.**

H04B 10/40 (2013.01)

H04B 10/80 (2013.01)

H04J 14/02 (2006.01)

H01L 23/538 (2006.01)

H04B 10/50 (2013.01)

(52) **U.S. Cl.**

CPC **H04B 10/801** (2013.01); **H01L 23/5384** (2013.01); **H04B 10/40** (2013.01); **H04B 10/503** (2013.01); **H04J 14/0278** (2013.01)

9 Claims, 16 Drawing Sheets

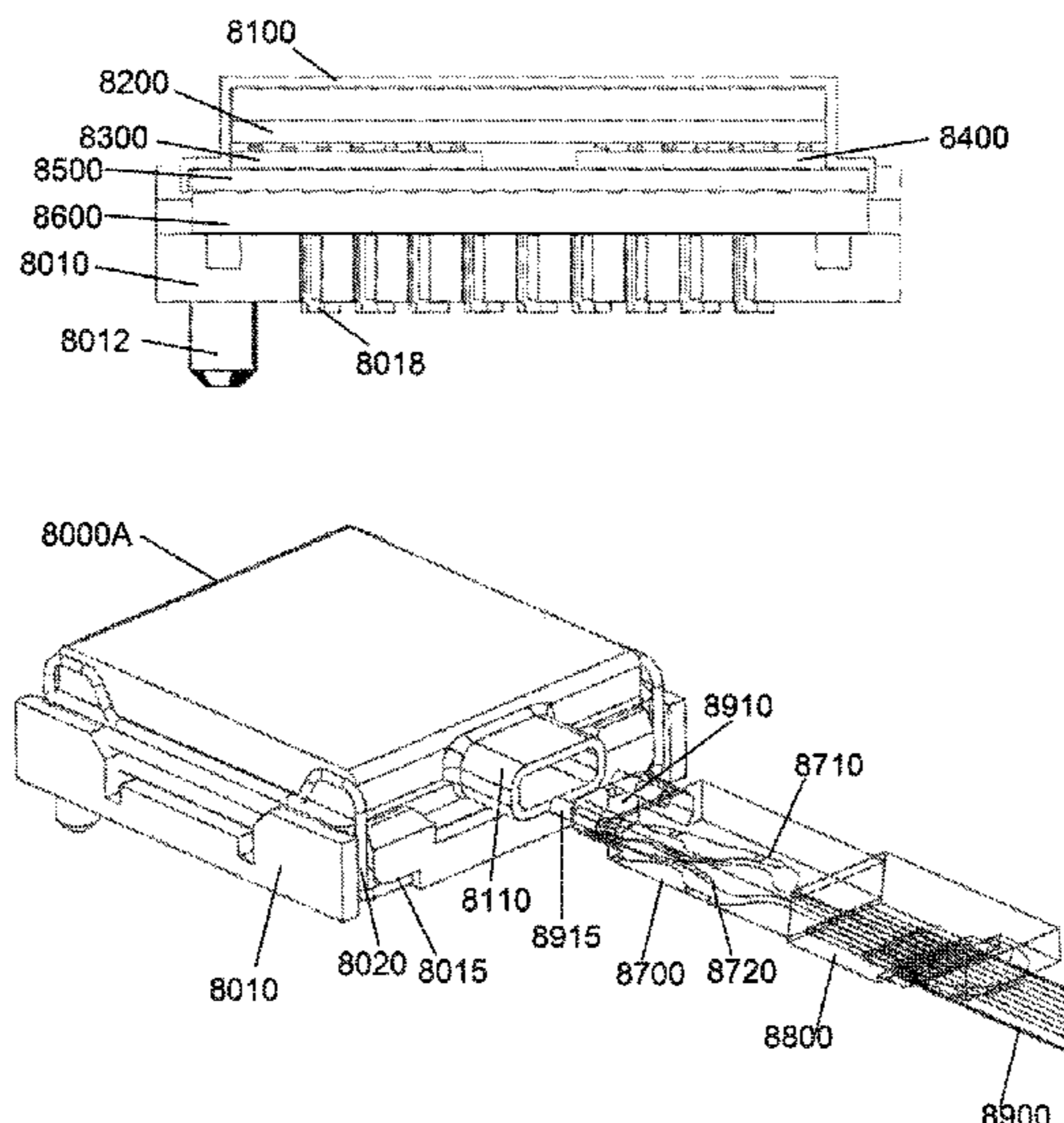

(56)

References Cited

U.S. PATENT DOCUMENTS

7,729,581 B2 6/2010 Rolston et al.
 9,496,959 B1 11/2016 Nagarajan et al.
 9,547,622 B1 1/2017 Nagarajan et al.
 9,548,817 B1 1/2017 Nagarajan et al.
 9,553,670 B2 1/2017 Nagarajan
 9,553,671 B1 1/2017 Nagarajan et al.
 9,584,884 B1 2/2017 Nagarajan
 9,651,751 B1 5/2017 Ding et al.
 9,671,580 B1 6/2017 Nagarajan et al.
 9,864,146 B1 1/2018 Fu et al.
 9,871,350 B2 1/2018 McLaurin et al.
 10,001,611 B2 6/2018 Ding et al.
 10,107,967 B1* 10/2018 Butler G02B 6/403
 10,365,445 B2 7/2019 Badihi
 10,566,287 B1 2/2020 Ding et al.
 10,615,567 B1 4/2020 Gelhausen et al.
 10,637,208 B1 4/2020 Nagarajan et al.
 10,733,138 B2 8/2020 Nagarajan
 10,739,828 B2 8/2020 Reed et al.
 10,754,091 B1 8/2020 Nagarajan
 10,826,613 B1 11/2020 Liang et al.
 10,942,323 B1 3/2021 Togami et al.
 10,951,003 B1 3/2021 He et al.
 2002/0040983 A1 4/2002 Fitzgerald
 2003/0013217 A1 1/2003 Dudoff et al.
 2004/0028312 A1 2/2004 Park et al.
 2005/0084269 A1 4/2005 Dallesasse et al.
 2006/0091538 A1* 5/2006 Kabadi H05K 7/1061
 257/737
 2006/0109883 A1 5/2006 Lewis et al.
 2006/0270283 A1 11/2006 Kumazawa et al.
 2008/0138088 A1 6/2008 Welch et al.
 2009/0016685 A1 1/2009 Hudgins et al.
 2009/0035940 A1 2/2009 Richardson et al.
 2009/0215291 A1* 8/2009 Taguchi H01R 13/193
 439/83
 2010/0098374 A1 4/2010 Althaus
 2012/0087620 A1 4/2012 Pardo et al.
 2013/0004120 A1 1/2013 Zbinden et al.
 2013/0148984 A1 6/2013 Kalogerakis et al.
 2013/0279845 A1 10/2013 Kobrinsky et al.
 2014/0003765 A1 1/2014 Tseng et al.
 2014/0079082 A1 3/2014 Feng et al.
 2014/0344496 A1 11/2014 Chan et al.

2015/0036278 A1* 2/2015 Yao G11C 29/56
 29/832
 2015/0295098 A1 10/2015 Toda
 2016/0163590 A1 6/2016 Jung et al.
 2016/0172253 A1 6/2016 Wu et al.
 2016/0334592 A1 11/2016 McColloch
 2017/0227724 A1 8/2017 Yamaji et al.
 2017/0254968 A1 9/2017 Ding et al.
 2017/0310078 A1 10/2017 Hirayama
 2017/0323787 A1 11/2017 Kuwabara et al.
 2017/0363827 A1 12/2017 Yang et al.
 2018/0019139 A1 1/2018 Sun et al.
 2018/0219350 A1 8/2018 Mohrle et al.
 2018/0231726 A1 8/2018 Mizuno et al.
 2018/0233880 A1 8/2018 Nadeau et al.
 2018/0254831 A1 9/2018 Ishii et al.
 2018/0351684 A1 12/2018 Osenbach et al.
 2019/0146167 A1 5/2019 Leigh et al.
 2019/0187391 A1 6/2019 Fujimura et al.
 2019/0237936 A1 8/2019 Pao
 2019/0281691 A1 9/2019 Matsui
 2019/0296828 A1 9/2019 Chan et al.
 2019/0391348 A1 12/2019 Osenbach et al.
 2020/0021079 A1 1/2020 Meade
 2020/0112373 A1 4/2020 Lai et al.
 2020/0116930 A1 4/2020 Kannan et al.
 2020/0136349 A1 4/2020 Igawa et al.
 2020/0144151 A1 5/2020 Bettman et al.
 2020/0162156 A1 5/2020 Parker et al.
 2020/0278426 A1 9/2020 Dummer et al.
 2020/0292769 A1 9/2020 Zbinden
 2020/0335940 A1 10/2020 Huang
 2020/0335942 A1 10/2020 Carson et al.
 2021/0175973 A1 6/2021 Liang et al.
 2021/0307153 A1* 9/2021 Mohammad H01L 23/4006

OTHER PUBLICATIONS

“Ranovus Launches Its Single Chip ODINTM Silicon Photonic Engine to Support ML/AI Workloads for Data Center and 5G Mobility”, Ranovus, Mar. 2020. (Year: 2020).
 Fatholouloumi et al., “1.6 Tbps Silicon Photonics Integrated Circuit for Co-Packaged Optical-IO Switch Applications”, Mar. 2020, OFC 2020, OSA. (Year: 2020).
 Max Maxfield, “ASIC, ASSP, SoC, FPGA—What’s the Difference?”, EE Times, 2014 (Year: 2014).

* cited by examiner

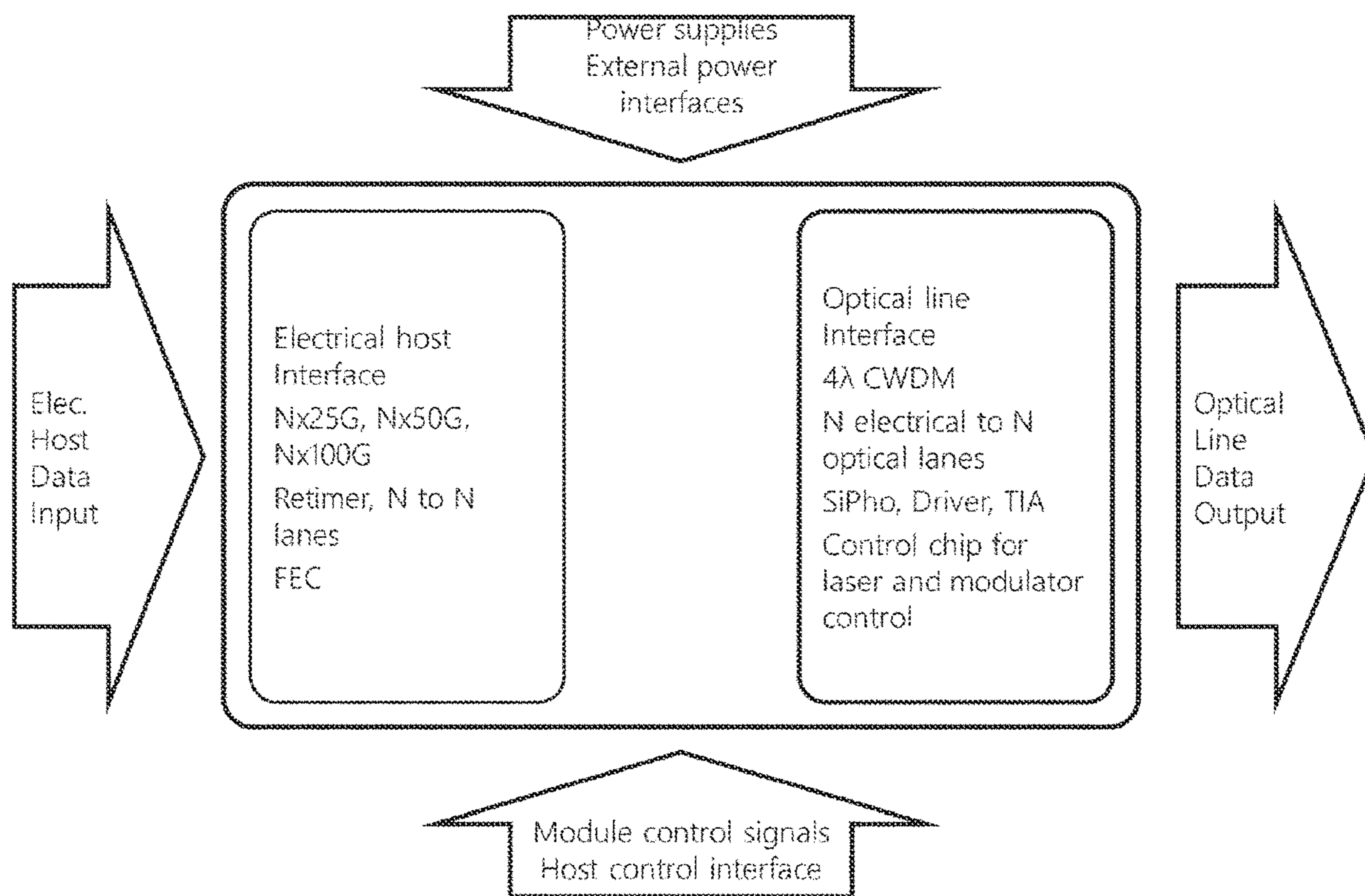

FIG. 1

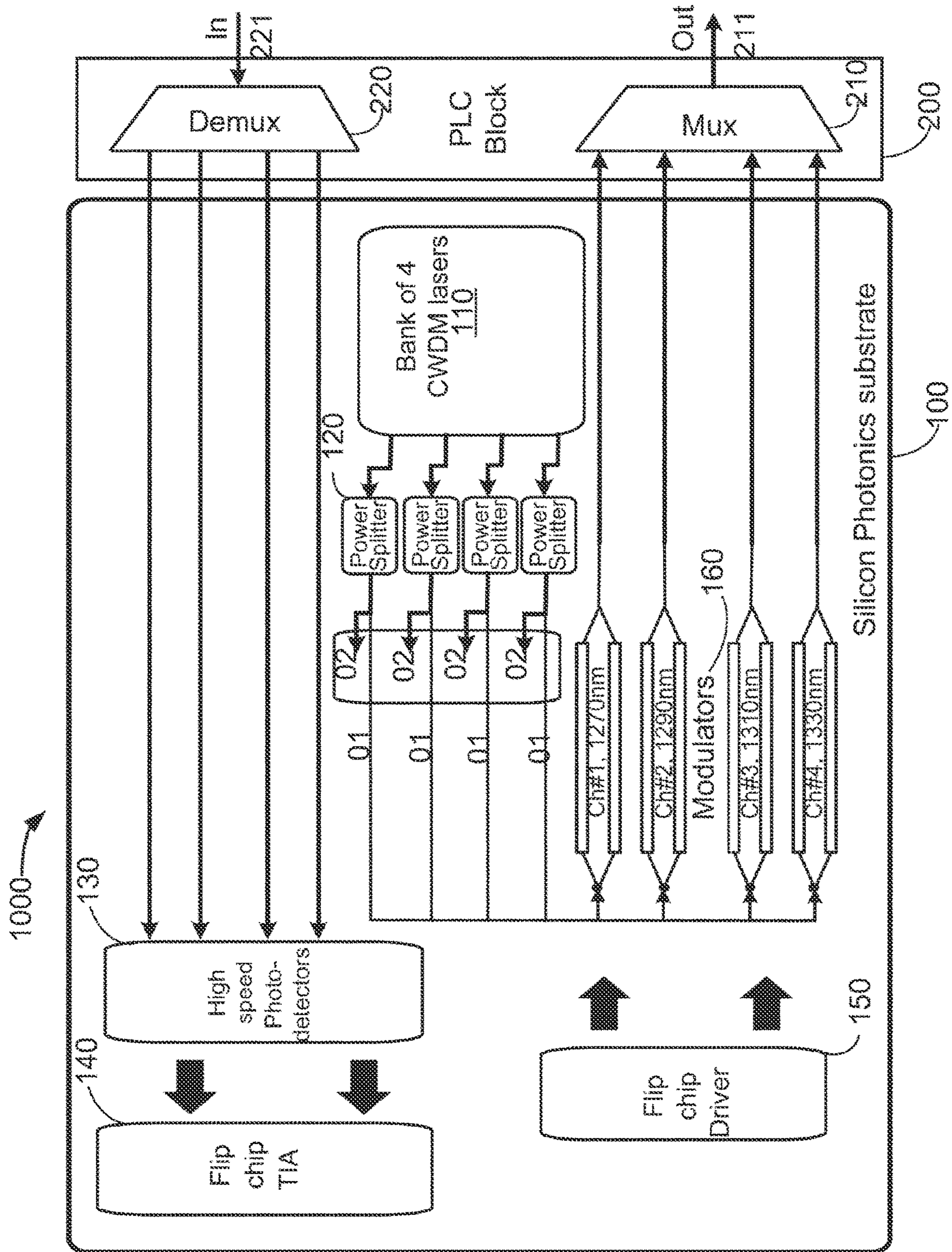

FIG. 2

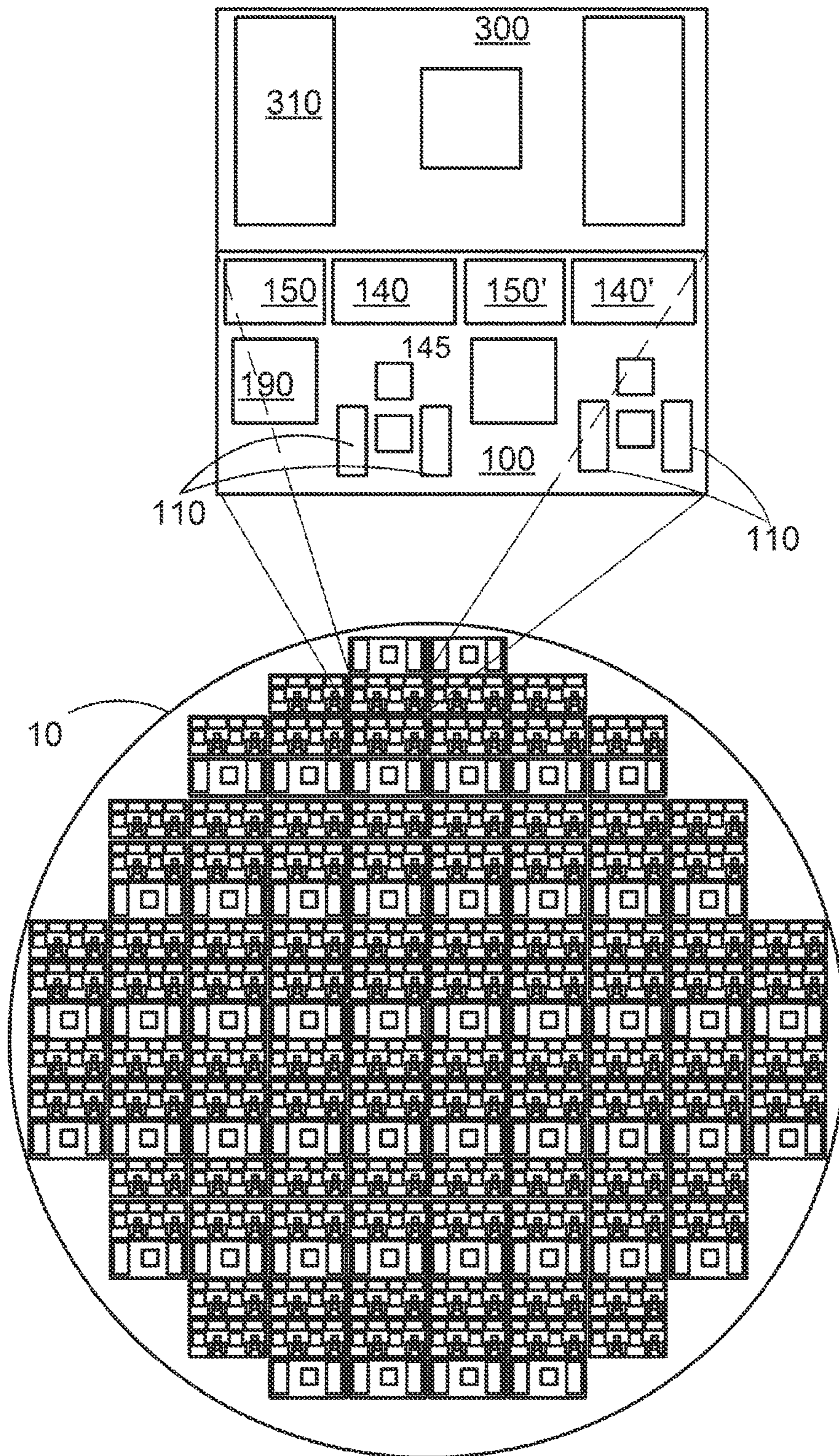

FIG. 3

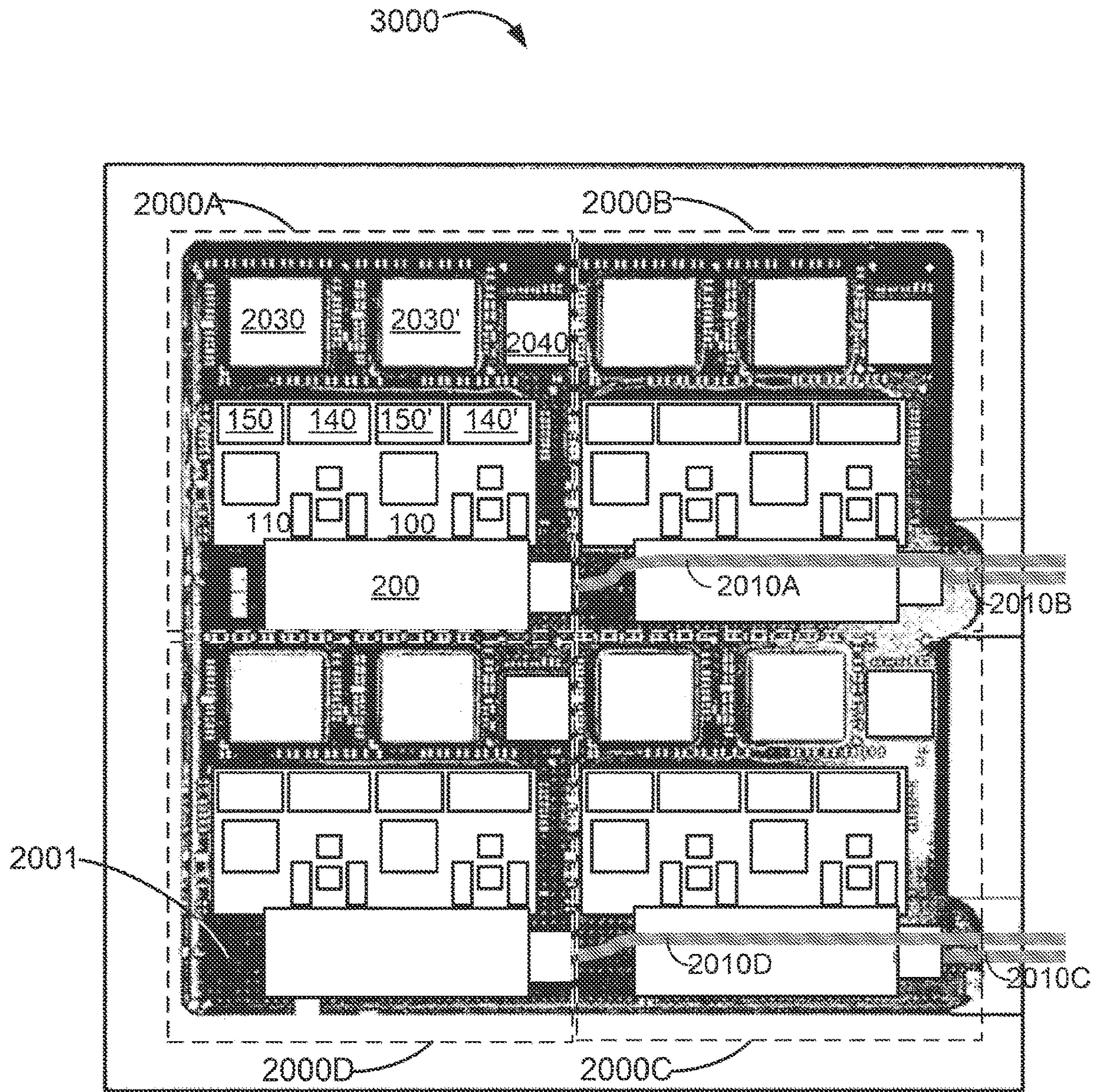

FIG. 4

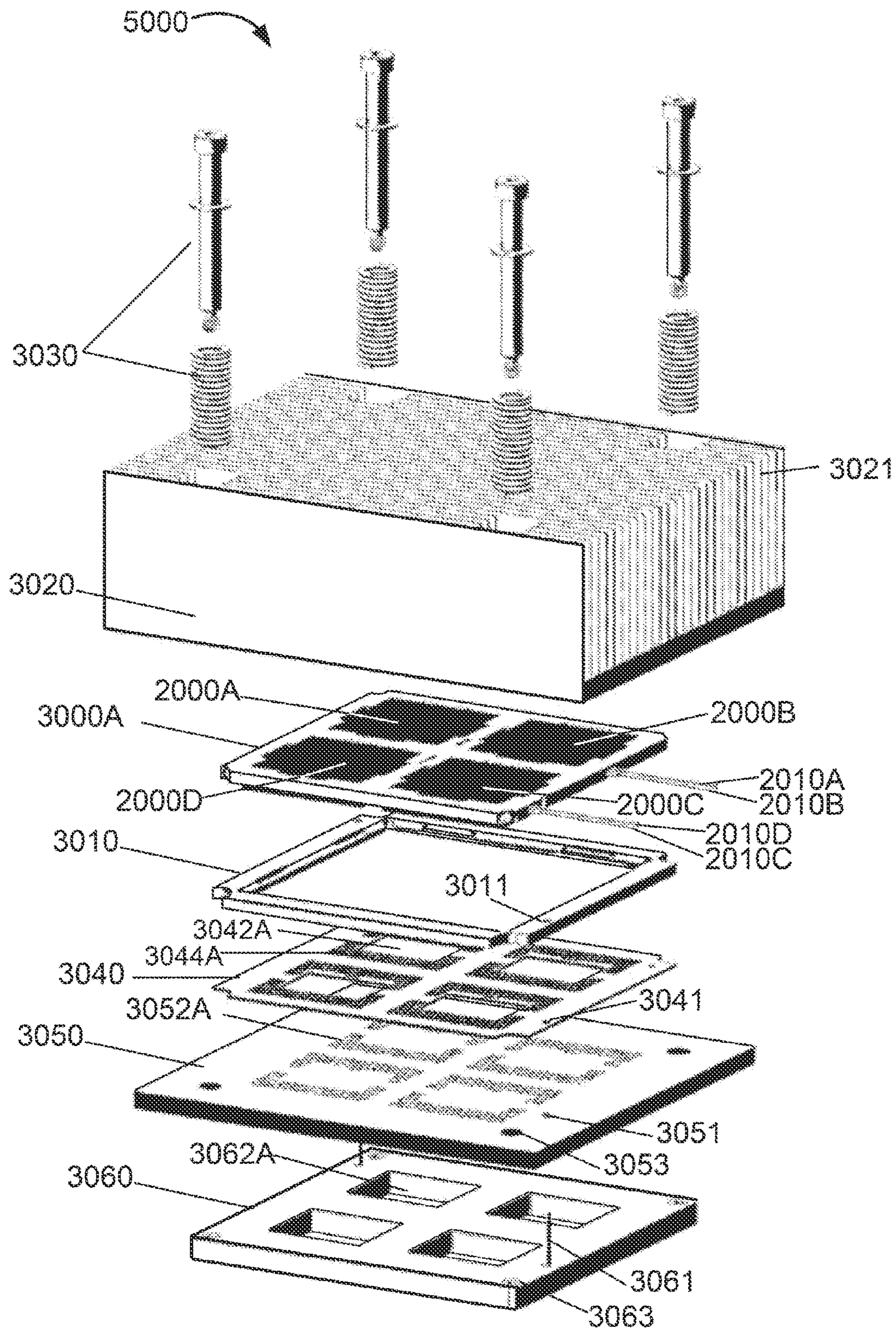

FIG. 5

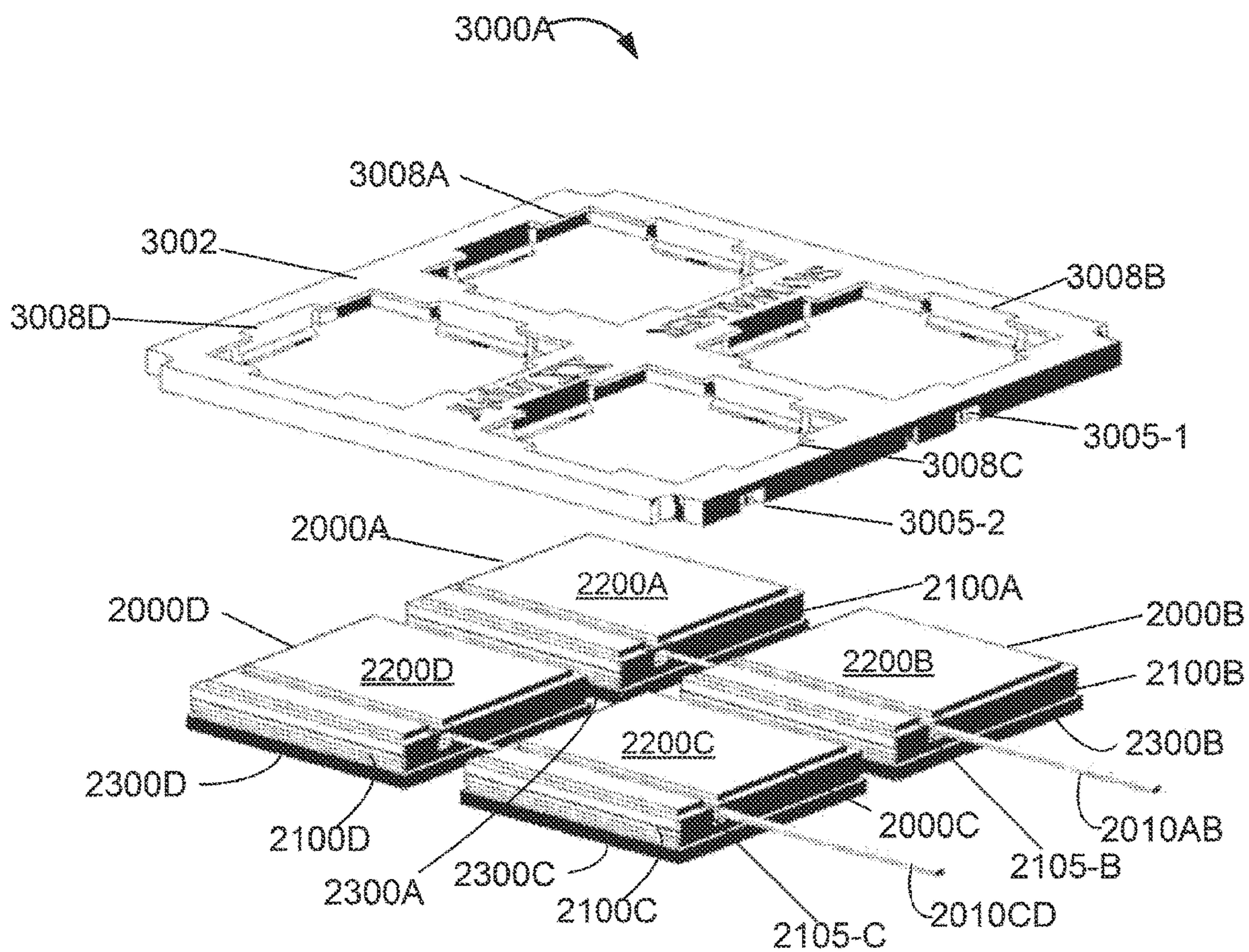

FIG. 6

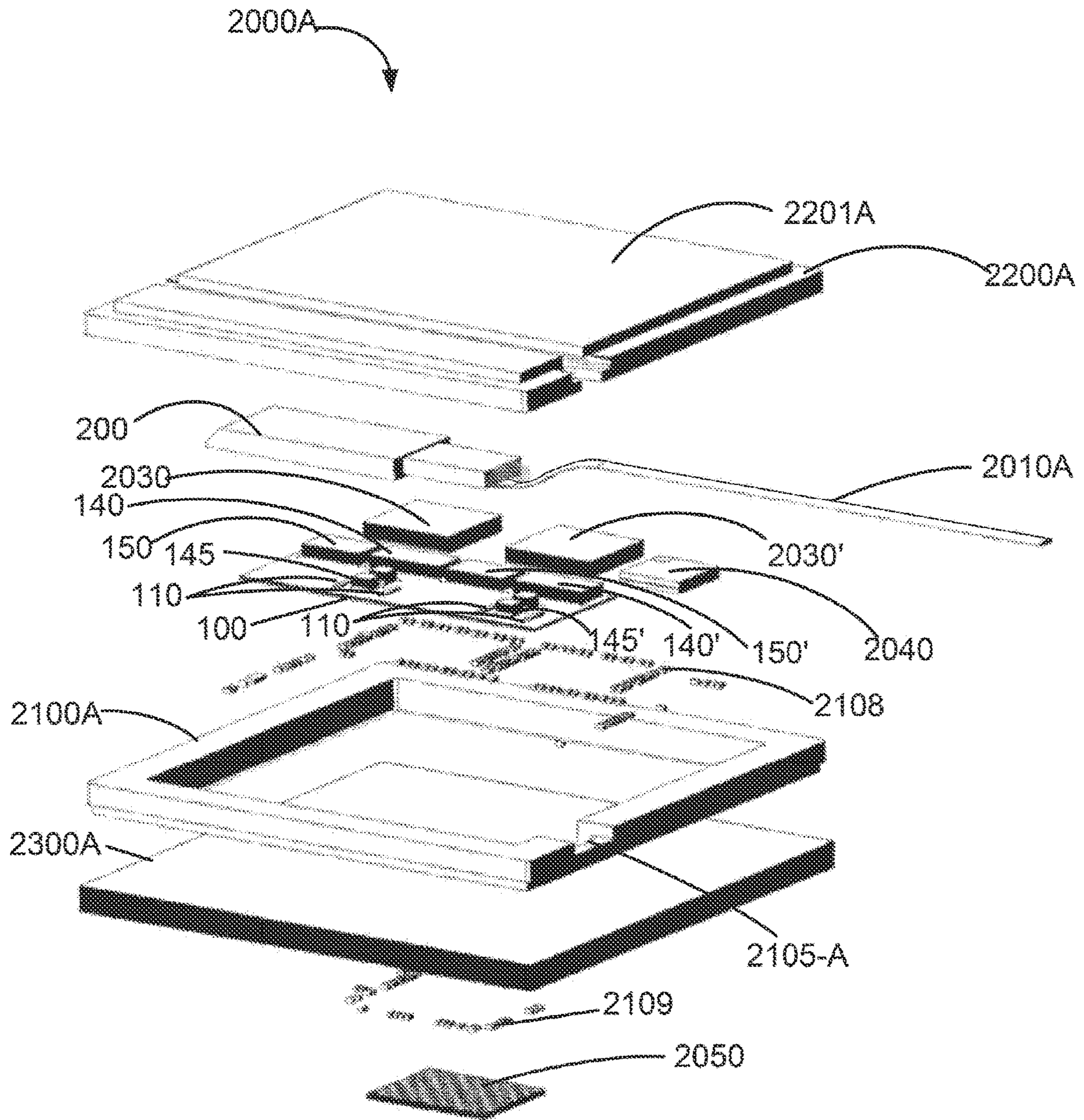

FIG. 7

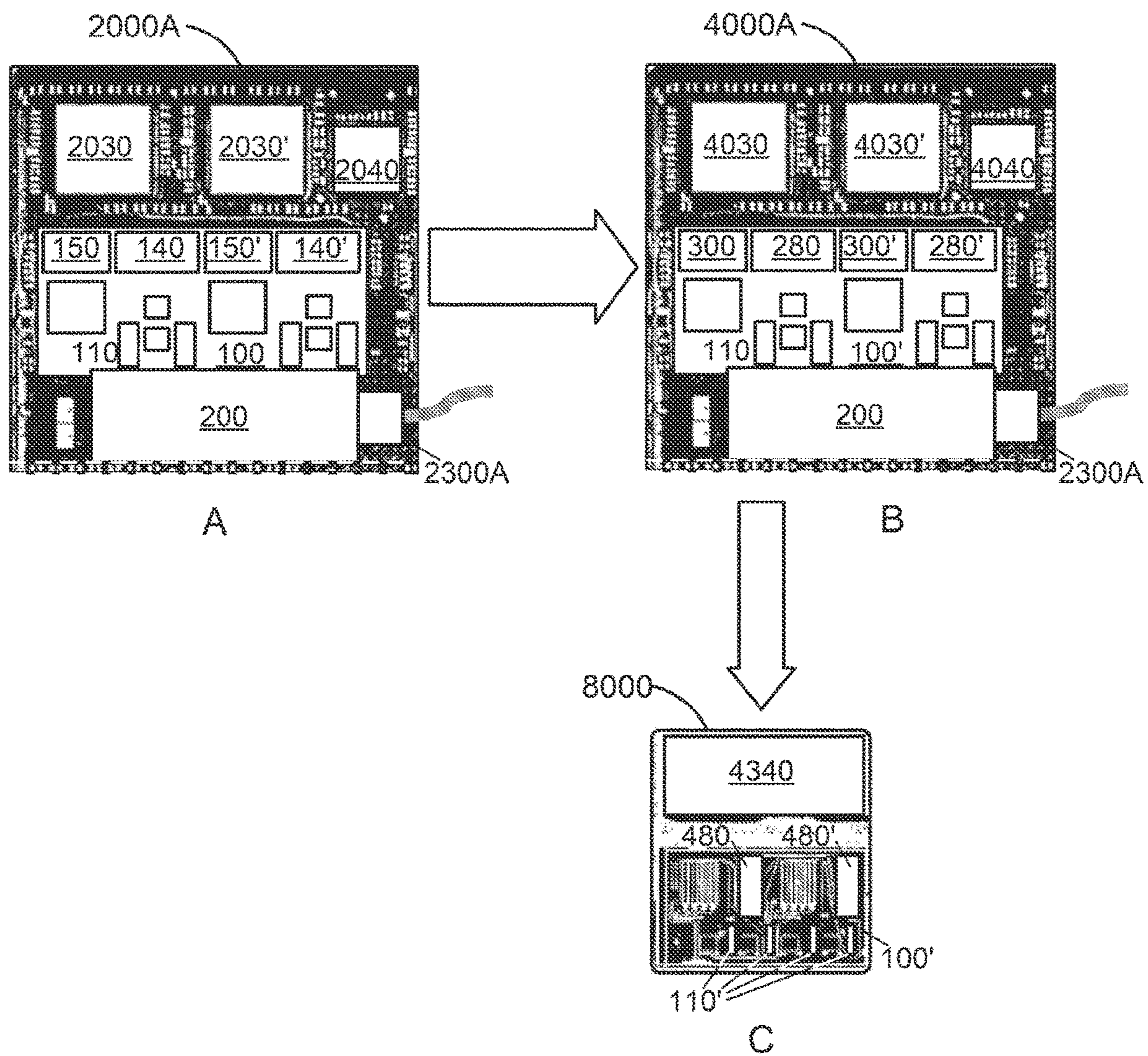

FIG. 8

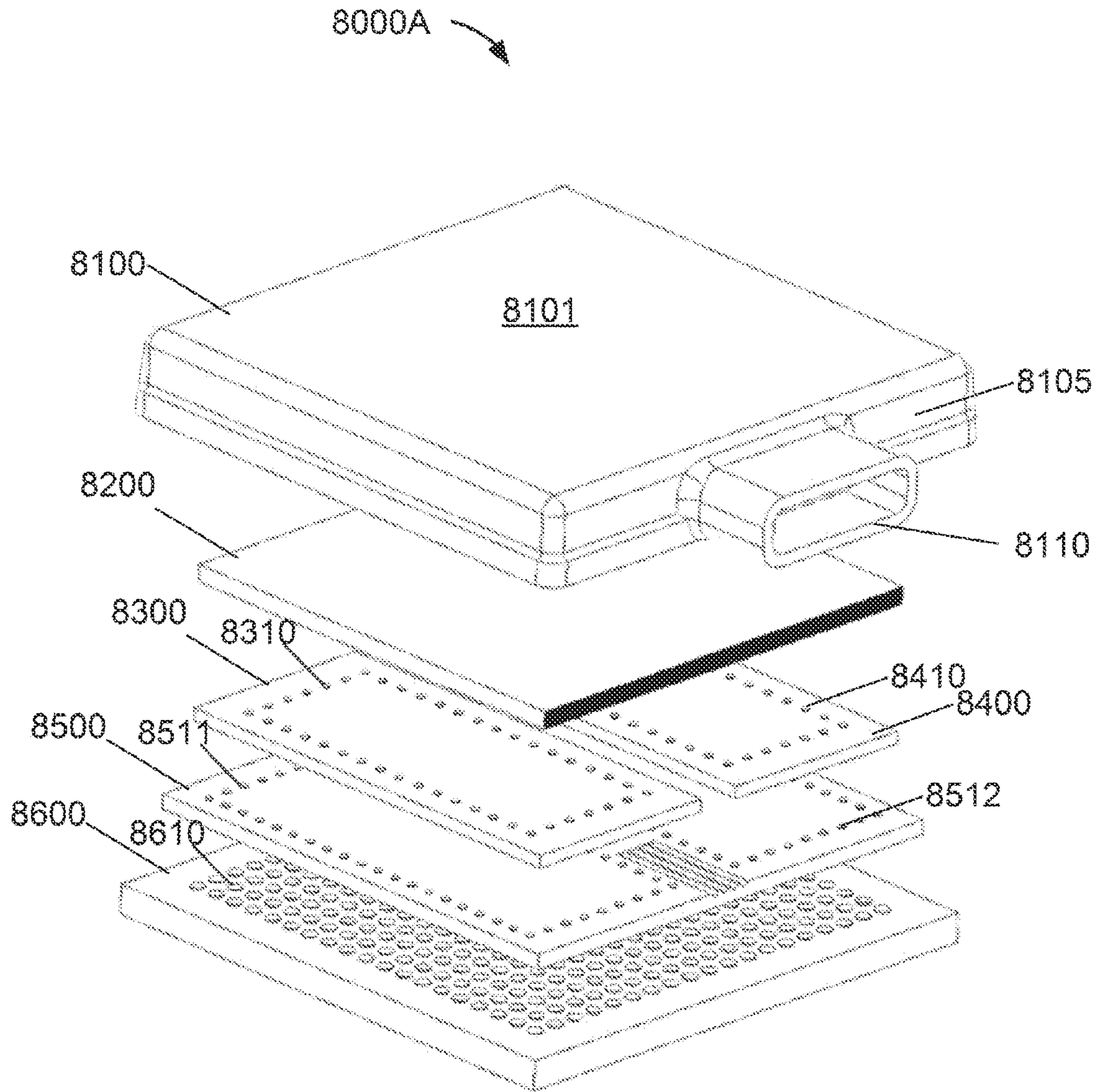

FIG. 9

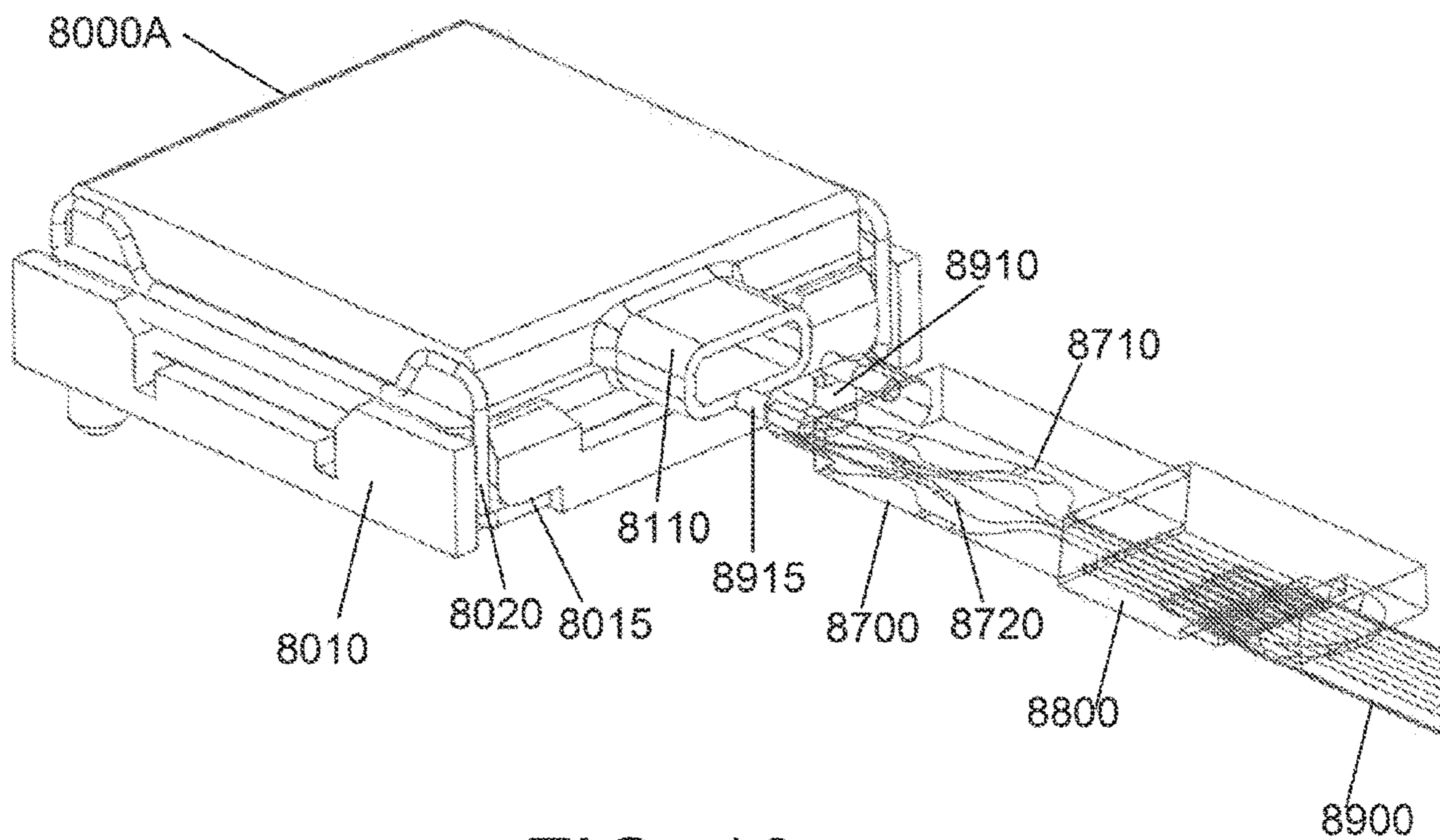
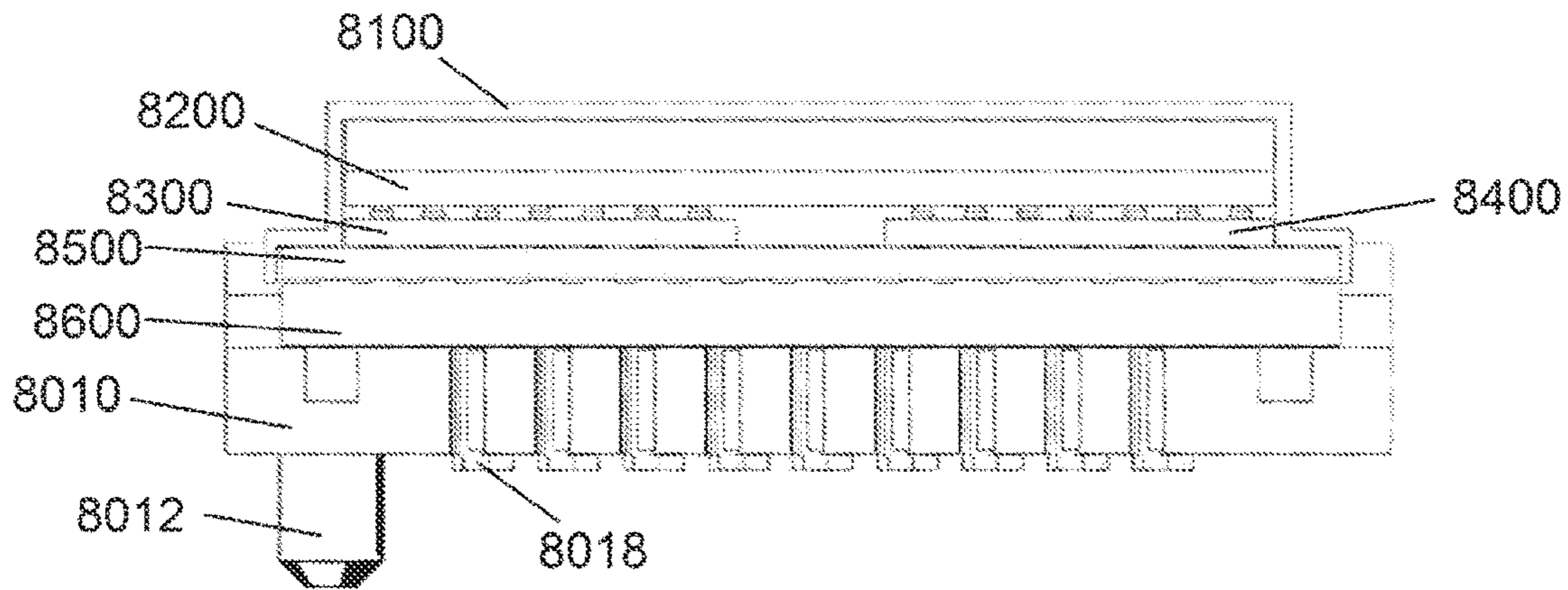

FIG. 10

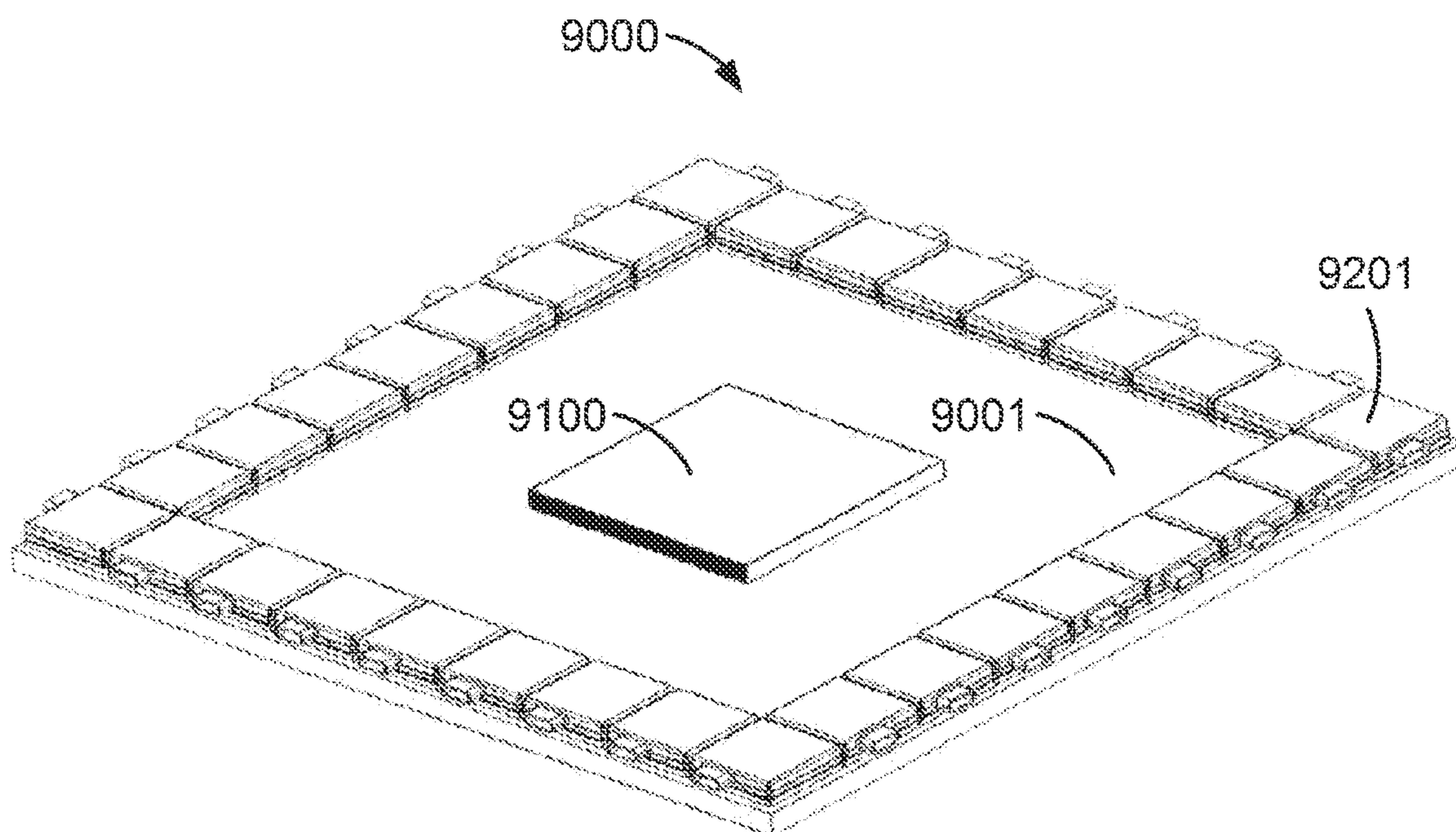

FIG. 11

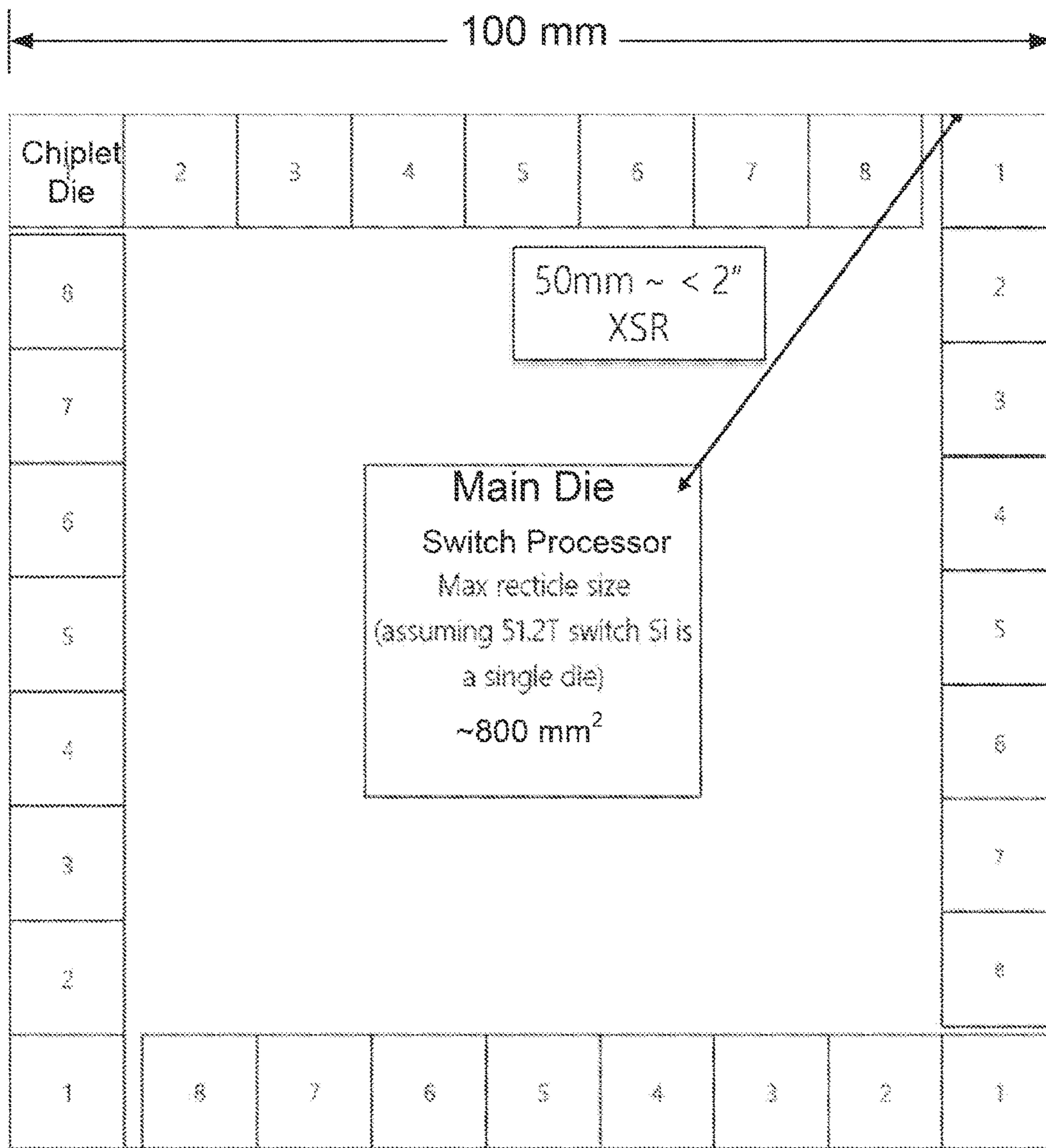

FIG. 12

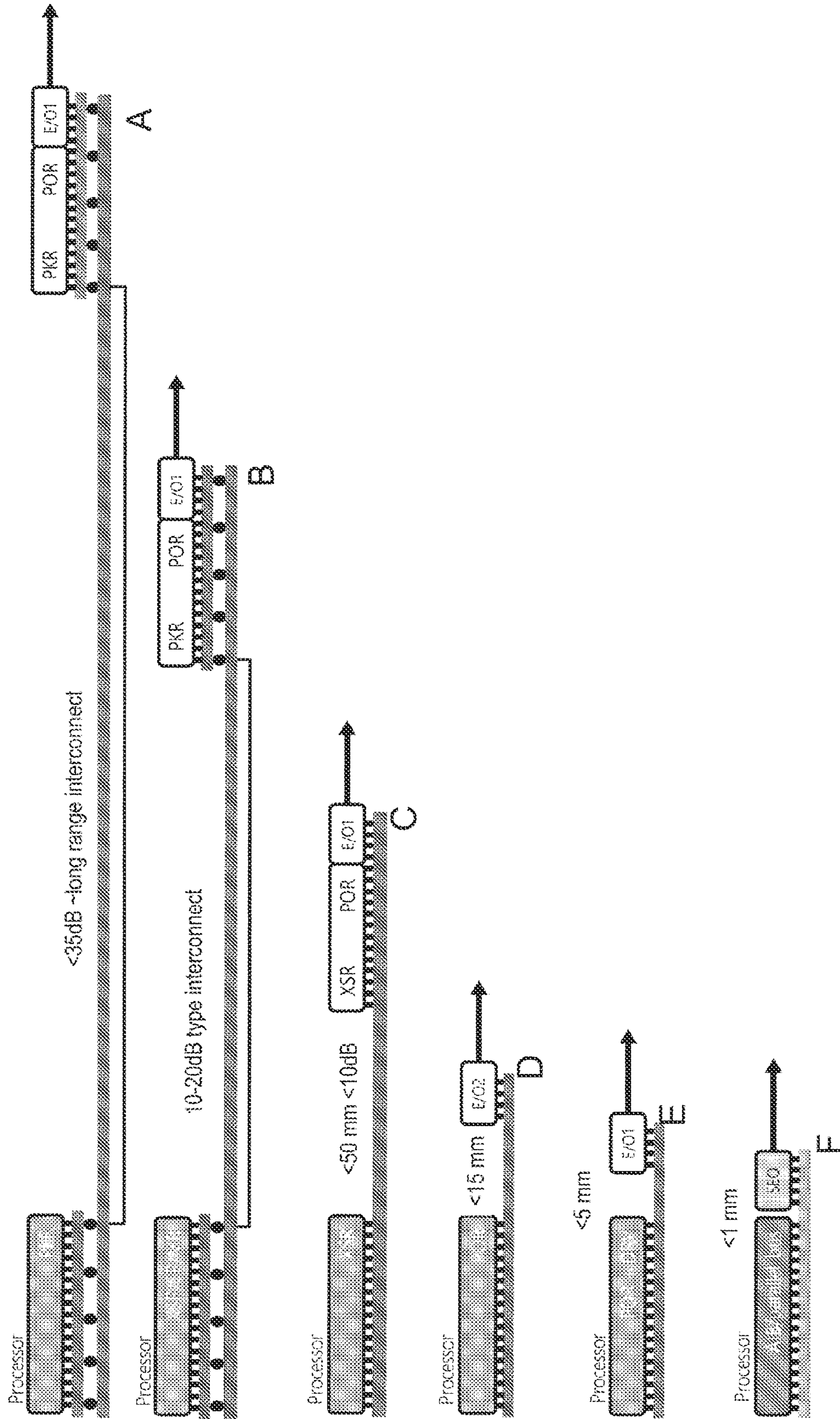

FIG. 13

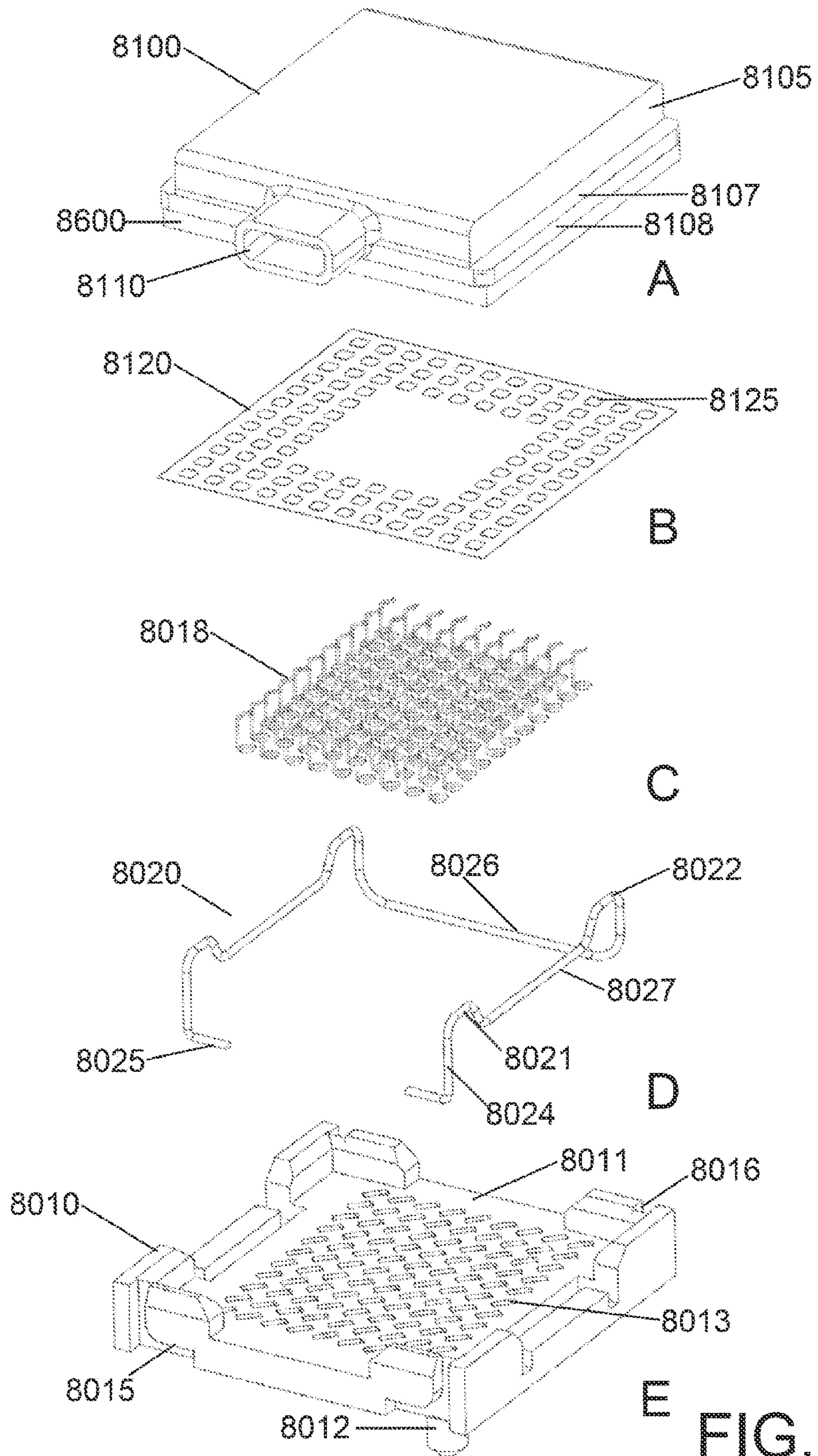

FIG. 14

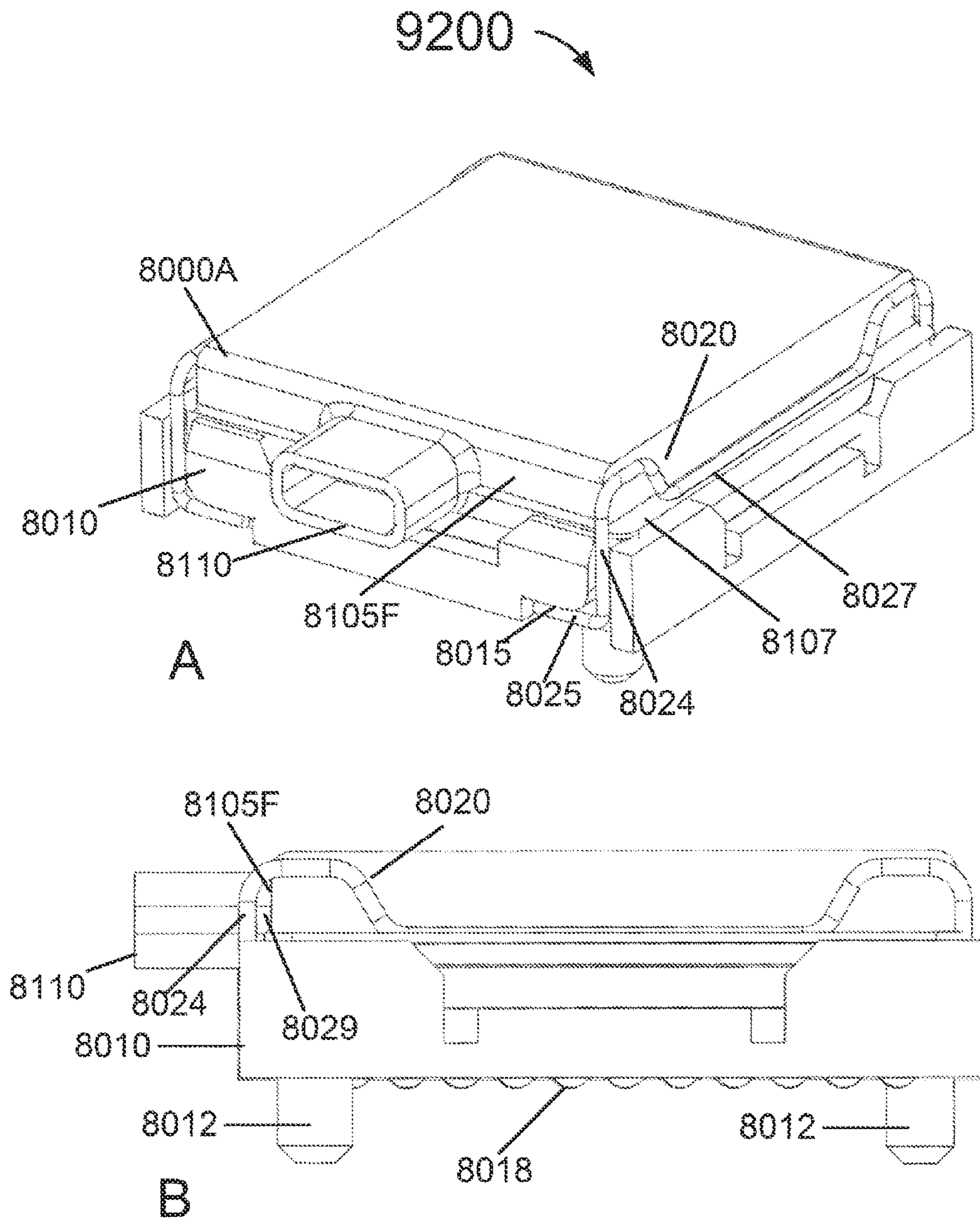

FIG. 15

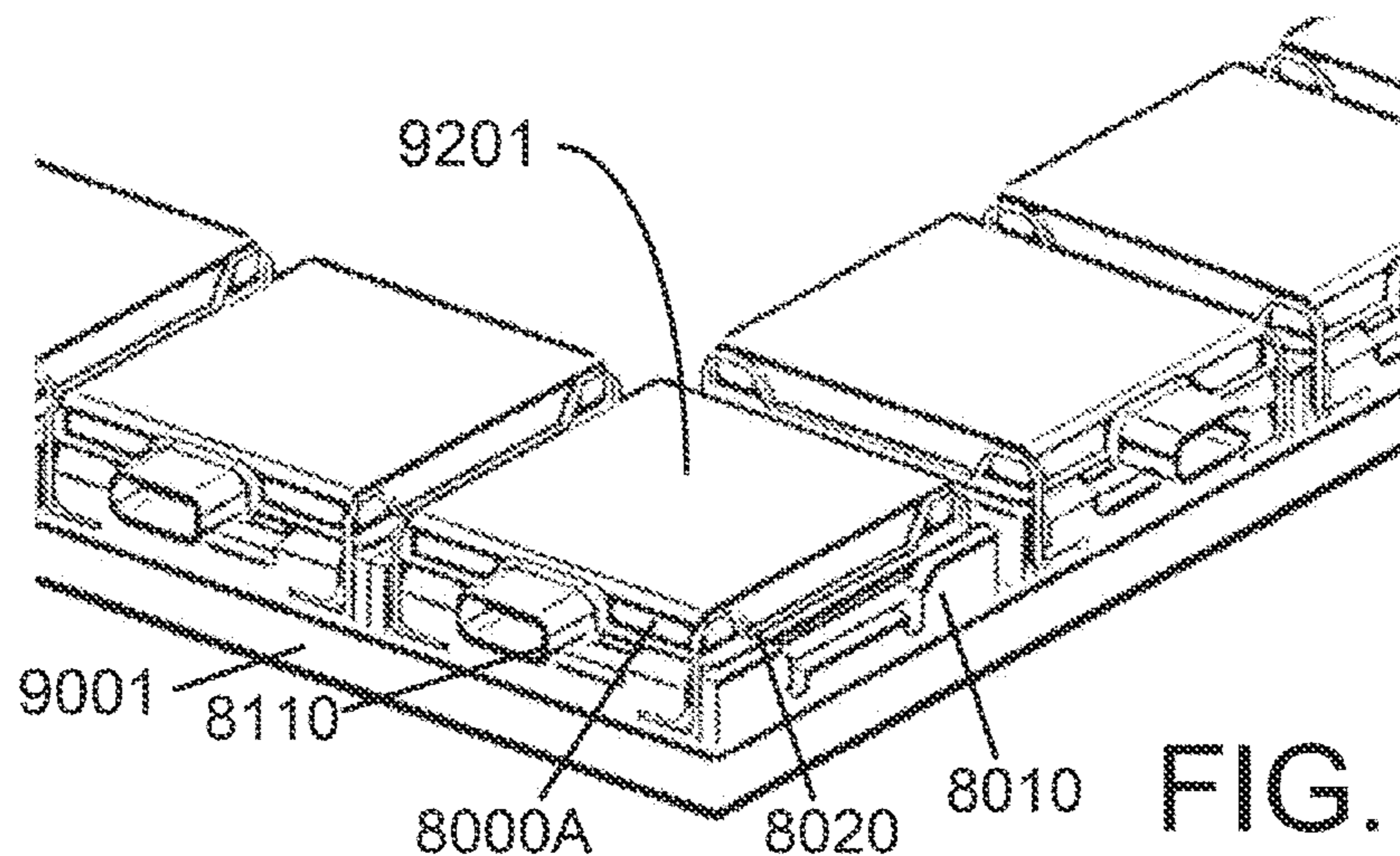

FIG. 16A

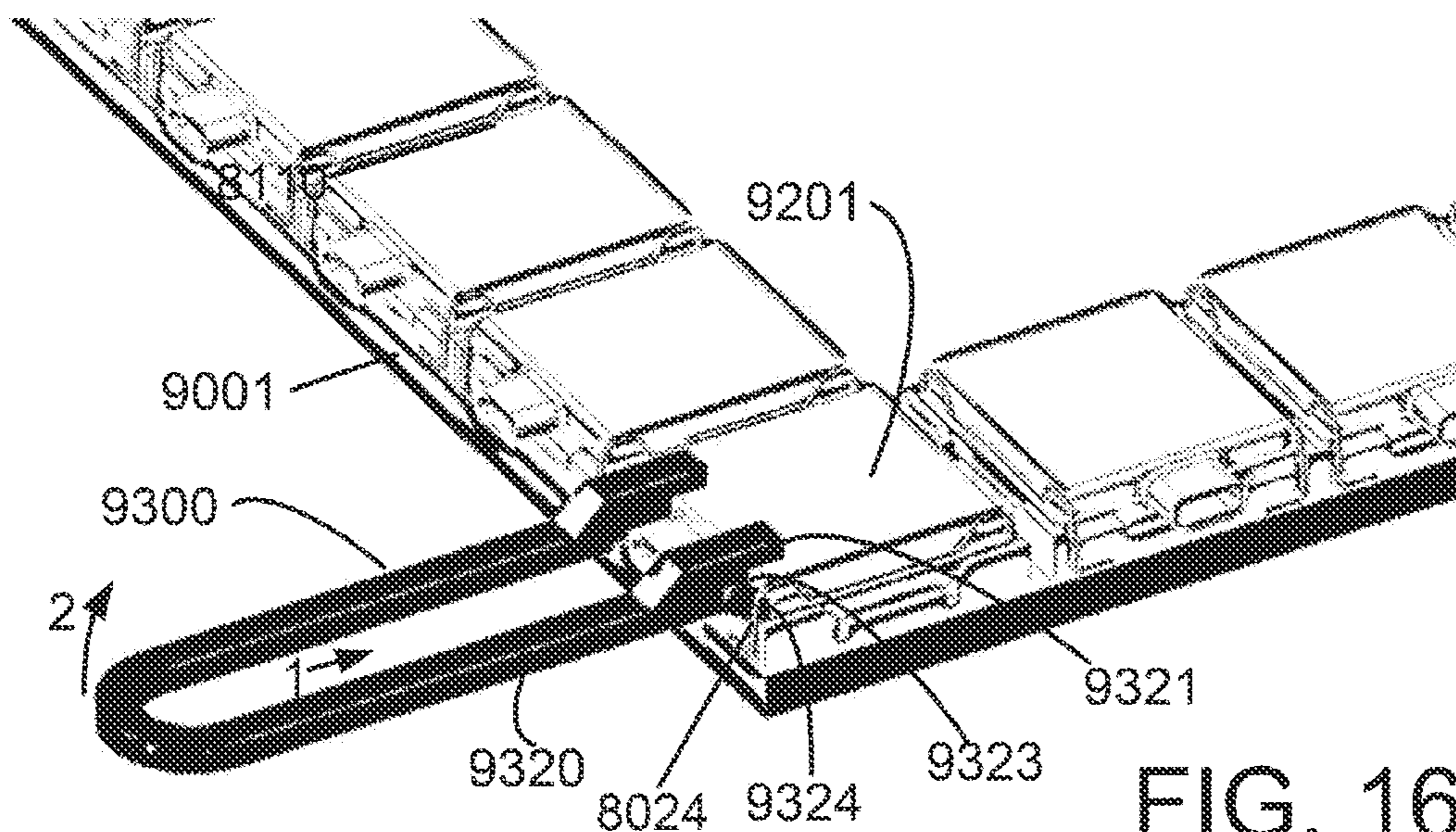

FIG. 16B

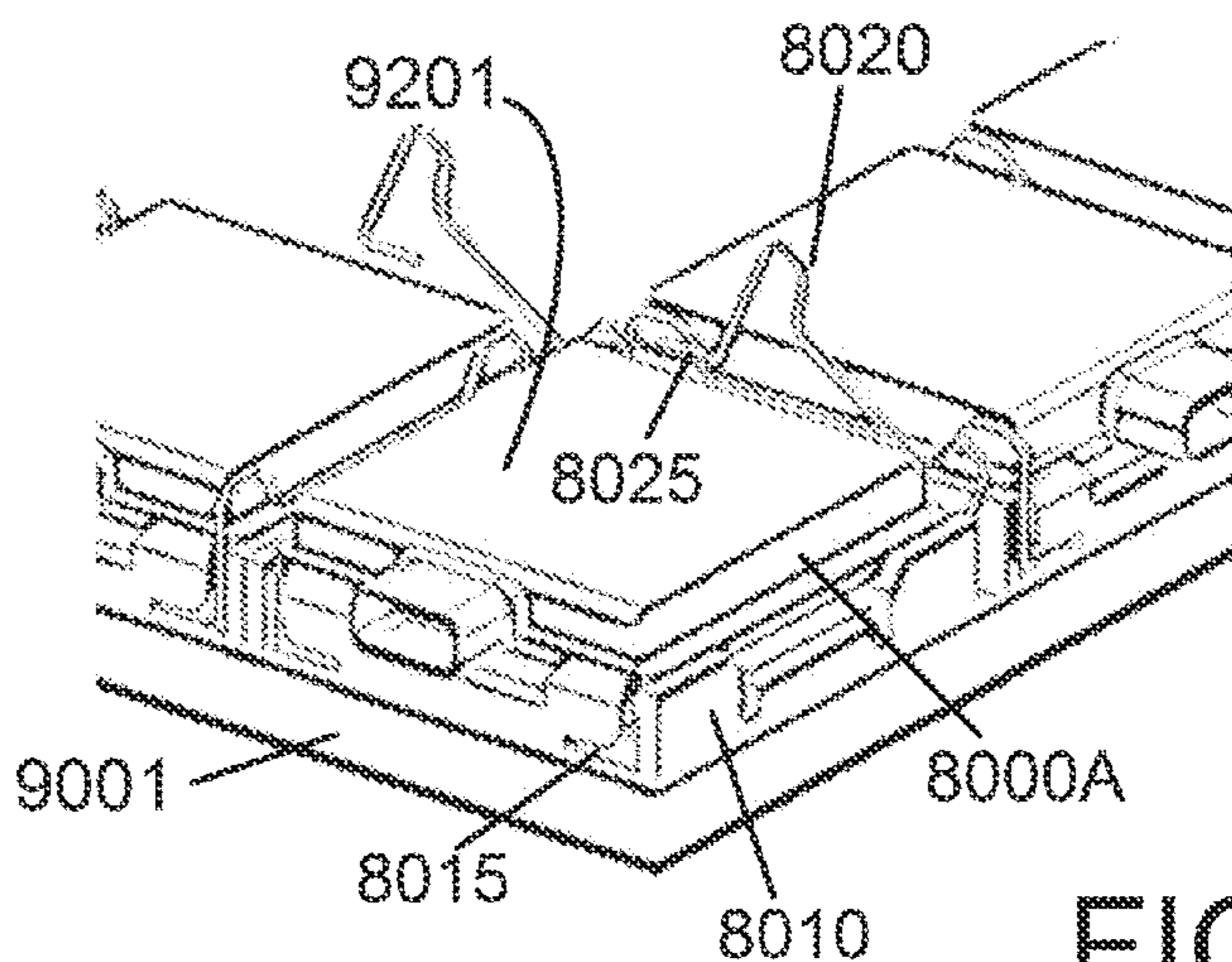

FIG. 16C

**METHOD FOR CO-PACKAGING LIGHT
ENGINE CHIPLETS ON SWITCH
SUBSTRATE**

**CROSS-REFERENCE TO RELATED
APPLICATIONS**

This application is a continuation of U.S. application Ser. No. 16/894,622, filed Jun. 5, 2020. The entire disclosure of the application referenced above is incorporated herein by reference.

This application is commonly assigned to MARVELL TECHNOLOGY CAYMAN I with U.S. application Ser. No. 16/894,597, filed concurrently on Jun. 5, 2020, and U.S. application Ser. No. 16/894,611, filed concurrently on Jun. 5, 2020, which are incorporated by reference herein for all purposes.

BACKGROUND OF THE INVENTION

The present invention relates to optical telecommunication techniques. More particularly, the present invention provides a method for co-packaging multiple light engine chiplets with a switch processor on a single switch substrate with minimum length of interconnect, a switch module having the co-packaged optics, and a method for unpackaging the light engine chiplet.

As science and technology are updated rapidly, processing speed and capacity of the computer increase correspondingly. The communication transmission or reception using the traditional cable is limited to bandwidth and transmission speed of the traditional cable and mass information transmission required in modern life causes the traditional communication transmission overload. To correspond to such requirement, the optical fiber transmission system replaces the traditional communication transmission system gradually. The optical fiber communication is chosen for systems requiring higher bandwidth and longer distance that electrical cable cannot accommodate. Present electronic industrial performs research toward optical transmission which will become the mainstream in the future even for short distance communication. Said optical communication is a technology in that light wave functions as signal carrier and transmitted between two nodes via the optical fiber. An optical communication system includes an optical transmitter and an optical receiver. By the optical transceiver, the received optical signal can be converted to an electrical signal capable of being processed by an IC, or the processed electrical signal can be converted to the optical signal to be transmitted via optical fiber. Therefore, objective of communication can be achieved.

Over the last few decades, the use of communication networks exploded. In the early days Internet, popular applications were limited to emails, bulletin board, and mostly informational and text-based web page surfing, and the amount of data transferred was usually relatively small. Today, Internet and mobile applications demand a huge amount of bandwidth for transferring photo, video, music, and other multimedia files. For example, a social network like Facebook processes more than 500 TB of data daily. With such high demands on data and data transfer, existing data communication systems need to be improved to address these needs.

40-Gbit/s and then 100-Gbit/s data rates wide-band WDM (Wavelength Division Multiplexed) optical transmission over existing single-mode fiber is a target for the next generation of fiber-optic communication networks. More

recently, optical components are being integrated on silicon (Si) substrates for fabricating large-scale silicon photonics integrated circuits that co-exist with micro-electronic chips. Chip-scale lasers packaged directly within silicon photonics opto-electrical system have been of interest for many applications such as wide-band DWDM or CWDM communication and wavelength-steered light detection. A whole range of photonic components, including filters, (de)multiplexers, splitters, modulators, and photodetectors, have been demonstrated, mostly in the silicon-on-insulator (SOI) platform. The SOI platform is especially suited for standard DWDM communication bands around 1550 nm or CWDM communication band around 1310 nm, as silicon ($n=3.48$) and its oxide SiO_2 ($n=1.44$) are both transparent, and form high-index contrast, high-confinement waveguides ideally suited for medium to high-integration planar integrated circuits (PICs).

With the advances of optical communication technology and applications driven by the market, the demands become stronger on increasing bandwidth for optical communication and decreasing package footprint of an optical transceiver. It is more and more challenging to integrate all necessary components within smaller and smaller module package. For the state-of-art optical transceiver products, all the critical components including clock data recovery (CDRs), modulator drivers, transimpedance amplifiers (TIAs), and PLC photonics blocks having optical passives, modulators, and photo detectors, are assembled side-by-side on a same SOI-based component substrate in a 2D fashion. This approach has at least two drawbacks for developing any future optical transceiver with data rate greater than 400G. Firstly, the side-by-side placement of the components consumes much of the board area for optical transceiver as a pluggable product or major substrate area for on-board optics product, making it very difficult to further shrink the product size. Secondly, side-by-side placement on the substrate creates longer electrical transmission length and often requires wire bonds between electrical die and photonics die, introducing more electrical loss which damages signal integrity for very high data rate transceiver product, e.g., >56 Gbaud symbol rate. In particular, the wire bonds lead to impedance mismatch due to large inductance, degrading the signal at higher frequencies. As such, it is not practical to use wirebond as electrical interconnect between chips or between chips and board for the applications where high frequency (e.g., >40 GHz) analog signal is transmitted. The large inductance of wire bonds has become a bottle neck of high-speed data transmission.

To shorten the interconnect length of conventional wire bonds between electronics devices (e.g., from modulator driver/TIA to digital signal processor DSP) or between electronics (driver/TIA) and photonics (e.g., CDR and PAM4 ASIC), people have started to use through-silicon via (TSV) process and silicon interposer in Si photonics die to replace wire bonds and make interconnections. With the advancement of silicon TSV manufacturing process for making Si photonics components and integrating active components with wafer-level assembly and burn-in testing, a co-packaged optical-electrical system that assembles an optical-electrical processor on a compact module substrate in very short interconnect length with multiple chiplet light engines would provide great high-performance benefit and desired bandwidth capacity for various applications involving backplane reach, or medium reach, or short reach, or extra-short reach interconnect switch for high-speed data communication.

BRIEF SUMMARY OF THE INVENTION

The present invention relates to optical telecommunication techniques. More particularly, the present invention provides a co-packaged optical-electrical module with a switch processor and multiple light engine chiplets mounted on a same switch substrate. Merely by example, the present invention discloses a light engine made from a photonics sub-module of multi-channel optical-electrical transceivers integrated on a single silicon photonics substrate in-packaged with multiple lasers to provide multiple CWDM channels carrying total 1.6 Tbit/s or higher capacity per light engine, a method for fixing a compact chiplet package of the light engine on the switch substrate and releasing the chiplet package therefrom, though other applications are possible.

In modern electrical interconnect systems, high-speed serial links have replaced parallel data buses, and serial link speed is rapidly increasing due to the evolution of CMOS technology. Internet bandwidth doubles almost every two years following Moore's Law. But Moore's Law is coming to an end in the next decade. Standard CMOS silicon transistors will stop scaling around 3 nm. And the internet bandwidth increasing due to process scaling will plateau. But Internet and mobile applications continuously demand a huge amount of bandwidth for transferring photo, video, music, and other multimedia files. This disclosure describes techniques and methods to improve the communication bandwidth beyond Moore's law.

In an embodiment, the present invention provides an in-packaged multi-channel light engine. The in-packaged multi-channel light engine includes four or more sub-assemblies of optical-electrical sub-modules. Each sub-assembly is assembled in a case formed with a lid member covering a peripheral side member over peripheral edge region of a sub-module substrate. Each optical-electrical sub-module includes at least four laser chips, one or more driver chips, and one or more trans-impedance amplifier (TIA) chips separately flip-mounted on a silicon photonics substrate and is coupled to an optical interface block and an electrical interface block commonly mounted on the corresponding sub-module substrate. The in-packaged multi-channel light engine further includes a first frame fixture with a crossly-joined bar across middle region to form four or more window structures configured to allow the four or more sub-assemblies to be fitted in respectively with top surfaces of the lid members on top and bottom sides of the corresponding sub-module substrates at bottom. Additionally, the in-packaged multi-channel light engine includes a second frame fixture configured to hold the first frame fixture with the four or more sub-assemblies. The in-packaged multi-channel light engine further includes an interposer plate having a top side with four or more first-sets of conducting bumps, a bottom side with four or more second-sets of patterned conducting bumps, and a plurality of through-plate conducting vias and interior conducting paths configured to connect the first-sets of conducting bumps with the four or more second-sets of patterned conducting bumps. Each first-set of conducting bumps is configured to bond to a respective sub-module substrate. Furthermore, the in-packaged multi-channel light engine includes a module substrate having a top side with four or more sets of conducting bump contacts configured to respectively bond to the four or more second-sets of conducting bumps. The in-packaged multi-channel light engine further includes a backplate member attached to a bottom side of the module substrate. Moreover, the in-packaged multi-channel light engine includes a top plate member configured to compress the second frame

fixture that holds the first frame fixture with the four or more sub-assemblies, the interposer plate, and the module substrate vertically together with the backplate member. The top plate member is configured as a heatsink with a plurality of fin structures.

In a specific embodiment, the present invention provides a sub-assembly of a multi-channel light engine. The sub-assembly includes a sub-module substrate severed as a bottom member and a peripheral frame member having four sides disposed along a peripheral region on a front surface of the sub-module substrate. The peripheral frame member has an open slot through at least one side. The sub-assembly further includes a silicon photonics substrate electrically bonded via through-substrate vias bump contacts on the front surface of the sub-module substrate. The silicon photonics substrate is configured to fabricate multiple Si-based waveguide devices therein. Additionally, the sub-assembly includes one or more driver chips, one or more transimpedance amplifier chips, and multiple laser chips separately mounted on the silicon photonics substrate and coupled to corresponding Si-based waveguide devices to form a transmitter unit and a receiver unit. The sub-assembly further includes an optical interface block containing multiple planar waveguides formed on a glass substrate mounted on the front surface of the sub-module substrate next to the silicon photonics substrate. The multiple planar waveguides are optically coupled to corresponding Si-based waveguide devices and optical fibers in a fiber cable laid through the open slot through the at least one side. The optical interface block is configured to deliver output transmitted from the transmitter unit to an output optical fiber and to receive incoming multi-wavelength light signal from an input optical fiber for the receiver unit. Furthermore, the sub-assembly includes an electrical interface block including multiple ASIC chips mounted on the front surface of the sub-module substrate or a back surface thereof and configured to receive data signals based on which control signals for the laser chips are generated for producing multi-channel optical signals and process digital signals converted from the incoming light signal for electrical host. Moreover, the sub-assembly includes a top lid member covering the peripheral frame member to enclose the light engine.

In an alternative embodiment, the present disclosure provides a packaged chiplet of a multi-channel light engine. The packaged chiplet includes a lid member connected with a periphery member having one edge with an optical connector port. Additionally, the packaged chiplet includes a sub-module substrate having a peripheral region configured to be attached with the periphery member to form an enclosure with the lid member. Furthermore, the packaged chiplet includes a first die comprising an application-specific integrated circuit (ASIC) chip configured to at least serve as a digital signal processing (DSP) interface. Moreover, the packaged chiplet includes a second die comprising a silicon photonics chip including Si-based waveguide devices coupled to multiple laser chips to respectively provide multiple different wavelengths for multiple channels of an optical transceiver. The second die is electrically coupled and physically stacked with the first die in the enclosure.

In another alternative embodiment, the present disclosure provides a co-packaged optical-electrical module. The co-packaged optical-electrical module includes a module substrate with a minimum lateral dimension no greater than 110 mm. Additionally, the co-packaged optical-electrical module includes a main die with a processor chip disposed at a central region of the module substrate. The processor chip being configured to operate with a digital-signal processing

(DSP) interface for extra-short-reach or equivalent protocol data interconnect. Furthermore, the co-packaged optical-electrical module includes a plurality of chiplet dies disposed densely along a peripheral region of the module substrate. Each chiplet die is configured to be self-packaged light engine on a sub-module substrate with a minimum lateral dimension to allow a maximum number of chiplet dies on the module substrate with a distance of any chiplet die from the main die smaller than 50 mm for extra-short-reach or equivalent protocol in data interconnect operation.

In yet another alternative embodiment, the present disclosure provides a packaged light engine. The packaged light engine includes a sub-assembly having a lid member connected with a periphery member configured as a front edge with an optical connector port, two opposing side edges with ledge structures, and a back edge opposing to the front edge. The sub-assembly further includes a sub-module substrate having a peripheral region configured to support the periphery member to form an enclosure with the lid member. Additionally, the sub-assembly includes a first die comprising an application-specific integrated circuit (ASIC) chip configured to at least serve as a digital signal processing (DSP) interface. Moreover, the sub-assembly includes a second die comprising a silicon photonics chip including Si-based waveguide devices coupled to multiple laser chips to respectively provide multiple different wavelengths for multiple channels of an optical transceiver. The second die is electrically coupled and physically stacked with the first die in the enclosure. The packaged light engine further includes an interposer pad disposed under the sub-module substrate. Additionally, the packaged light engine includes a socket base member having a flat plate connected to a peripheral wall structure having at least a front wall configured with at least two separated bottom notches and a back wall opposing to the front wall with one connected bottom notch and two side walls connected to the front wall and the back wall. The flat plate is recessed to receive the interposer pad and then the sub-module substrate as a part of the sub-assembly in an orientation with the optical connector port protruded out of a cutoff portion of the front wall. Moreover, the packaged light engine includes a shaped metal wire having a horizontal backside section fitted in the connected bottom notch in the back wall, two horizontal side sections pressed respectively on the ledge structures within the two side walls, and two end sections locked respectively in the two separated bottom notches in the front wall, and several bended sections for connecting the horizontal backside section, the two horizontal side sections, and the two end sections and providing elastic forces on the ledge structures to clamp the sub-assembly in the socket base member.

In still another alternative embodiment, the present disclosure provides a method for co-packaging multiple light engines in a switch module. The method includes a step of providing a module substrate with a minimum lateral dimension no greater than 110 mm. The module substrate is configured with a first mounting site at a center region and a plurality of second mounting sites distributed densely along peripheral region of the module substrate. Additionally, the method includes a step of disposing a main die with a switch processor chip at the first mounting site of the module substrate. The switch processor chip is configured to operate with a digital-signal processing (DSP) interface for extra-short-reach or equivalent interconnect. Furthermore, the method includes a step of mounting a plurality of chiplet dies respectively into the plurality of second mounting sites of the module substrate. Each chiplet die is configured to be

a packaged light engine with a minimum lateral dimension to allow a maximum number of chiplet dies co-packaged on the module substrate with a distance of any chiplet die from the main die smaller than 50 mm for extra-short-reach interconnect operation.

The present invention achieves these benefits and others in the context of known waveguide laser modulation technology. However, a further understanding of the nature and advantages of the present invention may be realized by reference to the latter portions of the specification and attached drawings.

BRIEF DESCRIPTION OF THE DRAWINGS

The following diagrams are merely examples, which should not unduly limit the scope of the claims herein. One of ordinary skill in the art would recognize many other variations, modifications, and alternatives. It is also understood that the examples and embodiments described herein are for illustrative purposes only and that various modifications or changes in light thereof will be suggested to persons skilled in the art and are to be included within the spirit and purview of this process and scope of the appended claims.

FIG. 1 is a simplified block diagram of an integrated optical-electrical sub-module according to an embodiment of the present invention.

FIG. 2 is an exemplary diagram of an optical-electrical transceiver integrating 4 lasers providing 4 CWDM channels plus 4 replicate channels according to an embodiment of the present invention.

FIG. 3 is a schematic top view of wafer level assembly of a plurality of in-packaged silicon photonics chips on a single substrate according to an embodiment of the present invention.

FIG. 4 is a schematic top view of an in-packaged optical-electrical module of four sub-module light engines according to an embodiment of the present invention.

FIG. 5 is an exploded view of a package for the optical-electrical module of FIG. 4 integrated with a heatsink and interfaced to a line card printed circuit board according to an embodiment of the present invention.

FIG. 6 is an exploded view of a sub-assembly of four sub-module light engines in the package of FIG. 5 according to an embodiment of the present invention.

FIG. 7 is an exploded view of a sub-assembly of one sub-module light engine in the sub-assembly of FIG. 6 according to an embodiment of the present invention.

FIG. 8 shows an evolution of a light engine chiplet with improved chip data capacity and reduced lateral dimension according to an embodiment of the present invention.

FIG. 9 is an exploded view of a sub-assembly of a light engine chiplet with reduced lateral dimension according to an embodiment of the present invention.

FIG. 10 is a cross-section view of the light engine chiplet of FIG. 9 clamped in a socket base and a perspective view of it configured to couple with an external PLC block integrated in an optical connector according to an embodiment of the present invention.

FIG. 11 is a perspective view of a switch module with a processor co-packaged with multiple light engines commonly on a switch substrate for extra short reach in data communication according to an embodiment of the present invention.

FIG. 12 is a schematic top view of the switch module of the FIG. 11 with a capacity of 51.2 Tbit/s on a switch substrate integrating eight light engine chiplets per each

peripheral side of the switch substrate according to the embodiment of the present invention.

FIG. 13 is a schematic diagram illustrating evolved integration schemes of moving light engines closer to a switch processor for reducing interconnect reach distance in high-speed data communication applications according to some embodiments of the present invention.

FIG. 14 is an exploded view of all parts of a package of a light engine chiplet to illustrate a method of packaging one of the multiple light engines in the co-packaged switch module according to an embodiment of the present invention.

FIG. 15 is (A) a perspective view and (B) a side view of the packaged light engine chiplet of FIG. 14 according to an embodiment of the present invention.

FIGS. 16A-16C show a method of releasing a sub-assembly from the packaged light engine chiplet of FIG. 15 according to an embodiment of the present invention.

DETAILED DESCRIPTION OF THE INVENTION

The present invention relates to optical telecommunication techniques. More particularly, the present invention provides an in-packaged optical-electrical module assembling multiple sub-modules on a single line card, each being configured as a multi-channel light engine containing an optical-electrical transceiver based on silicon-photonics platform. Merely by example, the present invention discloses a sub-assembly for the sub-module integrating 4 laser chips providing 4 CWDM channels plus 4 optional replicated CWDM channels on a single silicon photonics substrate, a compact package for multiple such sub-assemblies of sub-modules on a single line card providing 0.4 Tbit/s or higher per sub-module for building desired switching capacity in various applications of high-speed data communication with different interconnect lengths, though other applications are possible.

The following description is presented to enable one of ordinary skill in the art to make and use the invention and to incorporate it in the context of particular applications. Various modifications, as well as a variety of uses in different applications will be readily apparent to those skilled in the art, and the general principles defined herein may be applied to a wide range of embodiments. Thus, the present invention is not intended to be limited to the embodiments presented, but is to be accorded the widest scope consistent with the principles and novel features disclosed herein.

In the following detailed description, numerous specific details are set forth in order to provide a more thorough understanding of the present invention. However, it will be apparent to one skilled in the art that the present invention may be practiced without necessarily being limited to these specific details. In other instances, well-known structures and devices are shown in block diagram form, rather than in detail, in order to avoid obscuring the present invention.

The reader's attention is directed to all papers and documents which are filed concurrently with this specification and which are open to public inspection with this specification, and the contents of all such papers and documents are incorporated herein by reference. All the features disclosed in this specification, (including any accompanying claims, abstract, and drawings) may be replaced by alternative features serving the same, equivalent or similar purpose, unless expressly stated otherwise. Thus, unless expressly stated otherwise, each feature disclosed is one example only of a generic series of equivalent or similar features.

Furthermore, any element in a claim that does not explicitly state "means for" performing a specified function, or "step for" performing a specific function, is not to be interpreted as a "means" or "step" clause as specified in 35 U.S.C. Section 112, Paragraph 6. In particular, the use of "step of" or "act of" in the Claims herein is not intended to invoke the provisions of 35 U.S.C. 112, Paragraph 6.

Please note, if used, the labels left, right, front, back, top, bottom, forward, reverse, clockwise and counter-clockwise have been used for convenience purposes only and are not intended to imply any particular fixed direction. Instead, they are used to reflect relative locations and/or directions between various portions of an object.

In an aspect, the present disclosure provides an integrated optical-electrical sub-module based on silicon photonics platform and an in-packaged optics assembly of four sub-modules on one module substrate with 1.6 Tbit/s or higher optical lane speeds for PAM backplane/optical reach for various interconnect ranges of data communication. As data transmission-capacities increase in WDM systems, demand on high-speed, compact optical transceiver based on silicon photonics platform increasingly attract more and more interest over the recent years. For example, a pluggable optical transceiver in compact form factor. Yet, the compact optical transceiver is still a stand-alone device that needs to be coupled with separate passive optical devices like Mux/Demux and one or more gear box or retimer chips to connect with an electrical switch device to form a functional light engine, which requires a fairly large package size and high power-consumption.

FIG. 1 shows a simplified block diagram of an integrated optical-electrical sub-module according to an embodiment of the present invention. This diagram is merely an example, which should not unduly limit the scope of the claims. One of ordinary skill in the art would recognize many variations, alternatives, and modifications. As shown, in an embodiment, the integrated optical-electrical sub-module includes an electrical host interface configured to receive electrical host data input via N 25G (NRZ) or 50G (PAM4) or 100G (PAM4) channels and a digital processor to process the data signals via retimer chip having N to N lanes. Optionally, the digital processor processes the data signal via a gear box N to M lanes where N is a multiple of M. Optionally, the electrical host interface is configured in one or more chips including forward error correction (FEC) channel coding for controlling errors in data transmission over unreliable or noisy communication channels. In the embodiment, the integrated optical-electrical sub-module also includes an optical line interface configured with 4-wavelength CWDM lasers modulated to convert N electrical data into optical signals in N optical lanes. Optionally, a light engine with similar configuration can be formed with >4 wavelengths. Optionally, the 4 or more wavelengths may be chosen to have half spacing than nominal CWDM channels. The optical signals are transmitted via optical line data output multiplexed in a waveguide or optical fiber. Optionally, the laser chips, a Driver chip, and a Transimpedance Amplifier (TIA) chip are integrated on a silicon photonics substrate. Optionally, the silicon photonics substrate is mounted via an interposer on a same sub-module substrate for mounting the one or more chips containing the electrical host interface. Optionally, the silicon photonics substrate is the interposer. Optionally, an analog control chip for laser and modulator control is mounted on a backside of the sub-module substrate. Optionally, TIA chip or Driver chip or microcontroller chip can be mounted on the backside of the sub-module substrate as well. Optionally, the integrated optical-

electrical sub-module is configured to have an external power interface to couple with a power supply and receive module control signals via a host control interface such as I2C interface.

FIG. 2 is an exemplary diagram of an optical-electrical transceiver integrating 4 lasers providing 4 CWDM channels plus 4 replicate channels according to an embodiment of the present invention. This diagram is merely an example, which should not unduly limit the scope of the claims. One of ordinary skill in the art would recognize many variations, alternatives, and modifications. In an embodiment, the optical-electrical transceiver **1000** integrates four laser chips **110** with a driver chip **150** and a TIA chip **140** flip-bonded on a silicon photonics (SiPho) substrate **100** to form a SiPho chip coupled with an external planar light circuit (PLC) block **200**. As shown, the optical-electrical transceiver **1000** is specifically configured as a 4-wavelength CWDM optical transceiver including an optical receive path and an optical transmit path. In the optical receive path, it is configured to receive incoming four light signals with four wavelengths demultiplexed from one optical input **221**. In the optical transmit path, it is configured to output four light signals with four CWDM channel wavelengths multiplexed to one optical output **211**. A 4-to-1 multiplexer (Mux) **210** is a PLC waveguide device formed on a glass or sapphire substrate and configured to multiplex the four CWDM channel wavelengths into one waveguide or optical fiber. A 1-to-4 demultiplexer (Demux) **220** is another PLC waveguide device formed on the same glass or sapphire substrate and configured to demultiplex an incoming optical signal to four multiplexed wavelengths which carry high-speed modulated signals from the network. The optical-electrical transceiver **1000** also includes multiple high-speed photodetectors **130** to detect each of the four light signals with four demultiplexed wavelengths. In the embodiment, both the Mux **210** and Demux **220** are integrated in the PLC block **200**. Optionally, the PLC block **200** includes multiple optical waveguides formed in a single glass or sapphire substrate aligned with corresponding waveguides in the silicon photonics substrate **100**.

Referring to FIG. 2, the optical-electrical transceiver **1000** includes a bank of 4 CWDM lasers **110** respectively provide 4 light signals with respective CWDM channel wavelengths centered in 1270 nm, 1290 nm, 1310 nm, and 1330 nm. Optionally, each laser device is a DFB laser chip. Optionally, each laser chip **110** is provided as an individual laser chip fabricated separately and flip-mounted on the silicon photonics substrate **100**. Optionally, each light signal outputted from the respective one laser chip is aligned to a silicon waveguide built in the silicon photonics substrate **100**. Each light signal, through the silicon waveguide, is firstly coupled into a power splitter **120** and is split into two light signals in two separate branches with a split ratio varying from 5:95 to 50:50. Optionally, one split light signal from a minor split branch of the power splitter **120** is used for monitoring or wavelength locking or feedback control. Optionally, one light signal from one major split branch of the power splitter **120** is fed to one of four modulators **160**. Optionally, the power splitter is a 50:50 splitter, the light signal is converted to two replicate light signals, basically doubling the channel numbers. Each replicate light signal is fed into a modulator. Totally, the optical-electrical transceiver **1000** of FIG. 2 shows four modulators **160** respectively for receiving light signals from four first branches (**01**) while four other modulators for the four second (replicate) branches (**02**) are not explicitly shown. Of course, there can be many variations in functional setups or optical layouts to handle these light

signals and configure in different manners for different applications of the optical-electrical sub-module other than the one optical-electrical transceiver including 4 CWDM channels plus 4 replicate CWDM channels. For example, optionally, the optical-electrical transceiver **1000** is provided with a set (>4) of lasers with a smaller channel spacing than the CWDM channels to provide >4 wavelengths. The whole system will then have to operate in the same multi-wavelength plan.

Optionally, the modulator **160** in any one of first branch **01** is configured in a linear waveguide-based Mach-Zehnder modulation scheme. Each modulator **160** includes two waveguide branches with desired phase delay configured to match with respective one of four wavelengths 1270 nm, 1290 nm, 1310 nm, and 1330 nm of the four CWDM channels. Optionally, the four wavelengths can be selected from a group of 1270 nm, 1280 nm, 1290 nm, and 1300 nm or a group of 1300 nm, 1310 nm, 1320 nm, and 1330 nm with smaller channel spacing. Optionally, each wavelength is selected from a range from 1270 nm to 1330 nm as one CWDM channel to support the optical signal transmission in high-speed (e.g., 100 Gbit/s or higher) data communication. A Driver module **150** is provided as a separately fabricated CMOS or SiGe chip flip-mounted on the same silicon photonics substrate **100**. Optionally, a redundant or a replicate driver module **150'** (not shown in FIG. 2) is also provided as a chip flip-mounted on the same silicon photonics substrate **100** for driving the other four modulators in the replicate split branch (not shown). The driver module **150** is configured to drive all the four modulators **160** to modulate the light signals in the four CWDM channels. Optionally, one 8-channel driver is able to drive the 4 channels plus 4 replicate channels. Optionally, the driver module **150** employs PAM-N (N is an integer) modulation protocol or NRZ modulation protocol to modulate the light signal. For example, the modulators **160** are provided as silicon-waveguide-based Mach-Zehnder interferometer configured to provide PAM4 modulation though other formats can be employed. After modulation, the four CWDM channels of light signals are guided to the 4-to-1 multiplexer (Mux) **210** in the PLC block **200** which outputs a multiplexed light signal through an optical fiber (not shown) to an output port **211** of the sub-module **1000**. Optionally, there is another 4-to-1 Mux (yet not shown) formed in the PLC block **200** for combining the other 4 replicate CWDM channels of light signals to one multiplexed light signal which is through another fiber (not shown) led to the output port **211**. Effectively, a combination of the 4 laser chips **110** and 4 or 8 modulators **160** driven by the driver module **150** or plus a replicate driver module **150'** forms an integrated 4-ch optical transmit path plus another 4-ch replicate optical transmit path (not shown in FIG. 2).

Referring to FIG. 2 again, the optical-electrical transceiver sub-module **1000** includes a 4-ch optical receive path. In the optical receive path, the optical de-multiplexer (Demux) **220** in the PLC block **200** receives an incoming light signal via an input port **221** from an external network which is configured to operate under the four CWDM channel wavelengths for transmitting corresponding data signals. The incoming light signal carrying four multiplexed wavelengths is demultiplexed into 4 separate light signals in the respective 4 wavelengths guided into respective four waveguides formed in the silicon photonics substrate **100**. The High-speed photodetectors **130** are used to detect these four light signals separately and converted to respective electrical current signals. In the embodiment, the 4-channel optical receive path of the optical-electrical transceiver sub-module

11

1000 also includes a trans-impedance amplifier (TIA) module **140** for independently processing the electrical current signals converted from respective four separate light signals for communicating with host electrical network system via an electrical host interface. Optionally, the TIA module **140** is separately formed and flip-mounted on the same silicon photonics substrate **100**. Optionally, the optical-electrical transceiver sub-module **1000** also includes a replicate 4-ch optical receive path as the four replicate channel light signals can be demultiplexed from another incoming light by another demultiplexer. In the replicate 4-ch optical receive path, a replicate TIA module **140'** (not shown) can be included for independently processing four more electrical signals converted from respective four replicate light signals for communicating with host electrical network system with 2× expanded bandwidth. Optionally, the TIA module **140'** is also a flip chip mounted on the same silicon photonics substrate.

In another aspect, the present disclosure provides a fabrication process for the integrated optical-electrical sub-module based on silicon photonics platform such as the transceiver sub-module **1000**. In some embodiments, the fabrication process includes wafer level assembly of 2.5D silicon photonics substrate involving 2.5D silicon interposer and 220 nm silicon-on-insulator (SOI) substrate. The process includes monolithic formation of multiple silicon or silicon nitride waveguides in the silicon photonics substrate **100** for connecting or aligning with several different silicon photonics devices including power splitters, SiGe or Ge high-speed photodetectors, and Si/SiN-based Mach-Zehnder interferometer modulator devices formed in the same silicon photonics substrate **100**. The process also includes coupling the silicon waveguides with passive PLC devices such as optical multiplexers and demultiplexers formed on a glass or sapphire substrate and mounted onto the silicon photonics substrate as PLC block **200**. The process further includes flip-mounting active devices such as laser chips to the silicon photonics substrate as an in-packaged design and align the laser chips directly to the waveguides in the silicon photonics substrate or PLC devices in the PLC block. Optionally, some of the silicon photonics components mentioned above are also silicon waveguides themselves monolithically formed in a same manufacture process for preparing the silicon photonics substrate to integrate the optical-electrical transceiver sub-module **1000**.

FIG. 3 shows a schematic top view of a wafer level assembly of a plurality of in-packaged silicon photonics chips on a single substrate according to an embodiment of the present invention. This diagram is merely an example, which should not unduly limit the scope of the claims. One of ordinary skill in the art would recognize many variations, alternatives, and modifications. As shown, using the integrated optical-electrical transceiver sub-module as an example, the silicon photonics substrate **100** is one die fabricated from a CMOS compatible process plus a post CMOS wafer level assembly out of a SOI wafer **10**. In an example, each die **100** is used to form an optical-electrical module by directly processing the SOI wafer to form a silicon photonics through-substrate via (TSV) interposer. More details of the fabrication process involving the TSV interposer can be found in U.S. patent application Ser. No. 15/887,758 filed Feb. 2, 2018 and commonly assigned to Inphi Corp. Santa Clara, Calif. The as-mentioned application is incorporated by reference herein for all purposes. Utilizing the silicon photonics TSV interposer several optical or electrical components for forming the optical-electrical module can be directly mounted on. Referring to FIG. 3,

12

the one die **100** in the wafer **10** is enlarged out, showing that several electrical and optical components including two driver chips **150**, **150'**, two TIA chips **140**, **140'**, two dummy chips **190**, and four field effect transistors **145** (to apply bias to the laser chips **110**) is flip-mounted on the top side of the die in a post CMOS wafer level assembly. Especially, four laser chips **110** are also directly flip-mounted to respective chip sites on the die and optically aligned with waveguides formed therein as an in-packaged assembly without any wire bonding.

Additionally referring to FIG. 3, multiple redundant dies are arranged in multiple pairs of rows on the wafer substrate **10**. Each die **100** includes four CWDM laser chips **110**. The wafer substrate **10** also is configured to lay out multiple rows of blink probing pads **300** designed for conducting wafer level burn-in and testing conveniently. Each probing pad **300** includes electrodes **310** for easily coupling with external tester electrodes to allow proper bias current being applied in series to a plurality of laser chips on the wafer substrate **10**. More details on designing a chip site on the die for mounting a laser chip and performing wafer level burn-in and testing for the laser chip can be found in U.S. patent application Ser. No. 16/800,974, filed Feb. 25, 2020, which is commonly assigned to Inphi Corp. Santa Clara, Calif. and incorporated by reference herein for all purposes.

In yet another aspect, the present disclosure provides an in-packaged optical-electrical module assembling four optical-electrical sub-modules as mentioned above. FIG. 4 shows a schematic top view of an in-packaged optical-electrical module of four sub-module light engines according to an embodiment of the present invention. This diagram is merely an example, which should not unduly limit the scope of the claims. One of ordinary skill in the art would recognize many variations, alternatives, and modifications. In an embodiment shown in FIG. 4, the in-packaged optical-electrical module **3000** is provided by integrating four sub-modules **2000A**, **2000B**, **2000C**, and **2000D** evenly packaged in four compact areas on a common component substrate **2001**. Optionally, each sub-module is formed on its own component substrate which is named as a sub-module substrate.

Each of the four sub-modules in FIG. 4 is substantially redundant and independently functioned as a 4-wavelength transceiver driven by 4 in-packaged lasers to provide 4 light signals for 4 CWDM channels plus 4 replicate CWDM channels as shown in a block diagram of FIG. 2. Optionally, the in-packaged optical-electrical module can integrate two sub-modules. Optionally, the in-packaged optical-electrical module can integrate 6 sub-modules or more. Referring to FIG. 4, in an example, each 4-wavelength transceiver includes a silicon-photonics (SiPho) chip **100** diced from one die from the wafer substrate **10** of FIG. 3. The four CWDM channels are provided by four light signals at respective four CWDM channel wavelengths centered at, 1270 nm, 1290 nm, 1310 nm, and 1330 nm from respective 4 laser chips **110** that are directly flip-mounted on the SiPho chip **100** with its p-side facing toward the SiPho chip. The laser light emitted from each laser chip **110** is aligned to a Si-based waveguide formed in the SiPho chip **100**. Optionally, the Si-based waveguide includes an optical splitter to split the laser light to two branches to provide 4 CWDM channels and 4 replicate CWDM channels. Correspondingly, on each SiPho Chip **100**, one driver chip **150** and one TIA chip **140** are included for handling transmission and detection of light signals involving the 4 CWDM channels and one replicate driver chip **150'** and one replicate TIA chip **140'** are included for handling transmission and detection of light

signals associated with the 4 replicate CWDM channels. The SiPho chip **100** is coupled to a planar light circuit (PLC) block **200**, both being bonded to a top side of the corresponding sub-module substrate **2001**.

Optionally, each of the four sub-modules in FIG. 4, e.g., **2000A** in upper left portion, also includes a digital signal processing (DSP) chip **2030** plus an replicate one DSP chip **2030'** and a microcontroller chip **2040**, all mounted on the same top side of the sub-module substrate **2001** as the SiPho chip **100** and PLC block **200**. Both the driver chip **150** and the driver chip **150'** are interfaced via an electrical host interface with external electrical host system respectively through the digital signal processing (DSP) chips **2030** (and **2030'**) to handle the electrical data input from an electrical host. The DSP chips also are configured to interact via a host control interface with the microcontroller chip **2040** to provide module control and power supply required for operating the SiPho chip **100**. Optionally, the DSP chips **2030** and **2030'** include a gear box or retimer chip for converting analog signals to digital signals through N to N lanes electrical data transfer, a digital processor for processing the digital signals, one or more interface devices for communicating with external electrical host, and current drivers for driving the four laser chips. Optionally, the microcontroller chip **2040** is associated with a respective one sub-module **2000A** and is configured to control operations of the DSP chips **2030**, drivers **150**, TIA **140**, and interfaces therein. Optionally, the modulators in the SiPho chip **100** are configured to modulate the laser light signals based on PAM-N protocol, for example, PAM-4 protocol, or based on NRZ protocol. Optionally, the modulators are configured in a Mach-Zehnder Interferometer formed with Si-based waveguides in the silicon photonics substrate.

The PLC block **200** associated with each of the four sub-modules **2000A** (through **2000D**) includes at least a first optical multiplexer (see FIG. 2) in an optical transmit path to multiplex the four light signals of the four CWDM channels into one output light in one optical fiber and a second optical multiplexer in a replicate optical transmit path to multiplex the four replicated light signals into another output light in another optical fiber. Each optical multiplexer in the PLC block **200** is a planar waveguide formed on a glass or sapphire substrate and properly coupled to one optical fiber. Both optical fibers can be packaged into one on-board fiber cable **2010A** (through **2010D**) coupled between the PLC block **200**. For each sub-module, e.g., **2000A**, one optical transceiver transmits eight total output light signals carrying 4 CWDM channels plus 4 replicate CWDM channels to external optical network. In the embodiment, the compact in-packaged optical-electrical module **3000** totally includes four sub-modules **2000A** through **2000D**, delivering total 32 CWDM channel signals to the external optical network.

In the embodiment, the PLC block **200** associated with the same one of the four sub-modules, e.g., **2000A** (through **2000D**), also includes a built-in optical receive path configured to receive incoming light signals via optical fibers from network. The PLC block **200** includes at least a first optical demultiplexer to demultiplex an incoming light signal from one fiber (carrying 4 wavelengths) to four individual light signals with the respective four CWDM channel wavelengths. Each optical demultiplexer in the PLC block **200** is a planar waveguide formed on a glass or sapphire substrate properly coupled to one optical fiber. Each of the four individual light signals is coupled from planar waveguide in the PLC block **200** to the waveguides in the silicon photonics substrate and delivered to a photodetector block (referred

to FIG. 2). The photodetector block (**130** as shown in FIG. 2) individually detects and converts each light signal to an electrical current signal passed to and processed by a transimpedance amplifier (TIA) module **140** to generate a voltage signal. The voltage signal is further handled or digitized and processed by on-board DSP chip **2030** and fed to an external electrical host receiver. The incoming light signal as mentioned above can be received via an optical fiber that also is packaged into the on-board fiber cable **2010A**. Optionally, a second optical demultiplexer is included in the PLC block **200** for receiving and demultiplexing another incoming light signal carrying 4 replicate CWDM channel wavelengths into a replicate receive optical path to provide additional bandwidth with 4 replicate CWDM channels which can be separately detected by photodetectors and converted to corresponding electrical signals. The electrical signals can be processed by a replicated TIA module **140'** and digitally processed by DSP chip **2030'** in the same sub-module.

In this embodiment, PLC block **200** contains two 4-to-1 multiplexer and two 1-to-4 demultiplexer to create two sets of four light paths. For the multi-channel light engine **3000** that packages total four optical-electrical sub-modules **2000A**, **2000B**, **2000C**, **2000D**, it can detect different input light signals in 32 channels. In a case that each channel carries data in a rate of 50 Gbit/s, each quadrant sub-module delivers 400 Gbit/s in data rate with 4 CWDM lasers. The in-packaged optical-electrical module **3000** can provide 1.6 Tbit/s data switching communication capacity. In another case with improved modulators, driver chip, TIA chip, and DSP chip, each channel can carry 100 Gbit/s speed even though each quadrant sub-module uses the same 4 CWDM lasers. As a result, the in-packaged optical-electrical module **3000** can expand its data switching communication speed up to 3.2 Tbit/s.

In still another aspect, the present disclosure provides a packaging assembly of the in-packaged optical-electrical module of FIG. 4 as mentioned above. The packaging assembly are illustrated with several exploded views in FIGS. 5, 6, and 7 in different levels of revelation of the packaging structures and mounting fixtures for sub-modules and components therein. FIG. 5 is an exploded view of a packaging assembly **5000** of the in-packaged optical-electrical module of FIG. 4 integrated with a heatsink and interfaced to a module line card based on a printed circuit board according to an embodiment of the present invention. FIG. 6 shows a sub-assembly **3000A** for packing four sub-modules within the packaging assembly of the four sub-modules in FIG. 5 according to an embodiment of the present invention. FIG. 7 shows a detailed sub-assembly **2000A** of all components in one sub-module in FIG. 5 and FIG. 6 according to an embodiment of the present invention. These diagrams are merely examples, which should not unduly limit the scope of the claims. One of ordinary skill in the art would recognize many variations, alternatives, and modifications.

As shown in FIG. 5, the packaging assembly **5000** is provided by compressing a sub-assembly **3000A** of the multi-channel light engine **3000** of FIG. 4 between a top plate member **3020** on top and a backplate member **3060** at bottom. The sub-assembly **3000A** of the in-packaged optical-electrical module **3000**, as shown in FIG. 6, includes a single piece of solid frame fixture member **3002** having two crossly-linked middle bars to form four closely packed window structures, **3008A**, **3008B**, **3008C**, and **3008D**. The four window structures are designed to allow respective four sub-assemblies, i.e., **2000A**, **2000B**, **2000C**, and **2000D** to fit in. Each sub-assembly (e.g., **2000A**) is designed to have the

corresponding sub-module packaged within a case enclosed by a lid member **2200A** on top sealed with a peripheral side member **2100A** around a peripheral region of a sub-module substrate **2300A** at bottom. FIG. 7 shows package structures and component layouts within each sub-assembly of a sub-module (e.g., **2000A**). More details will be described in following paragraphs.

Referring to FIG. 6, the solid fixture member **3002** includes notches **3005-1** and **3005-2** at least partially opened downward at one middle bar and one side of the frame fixture member **3002**. The lid member (e.g., **2200B**) of each sub-assembly (e.g., **2000B**) includes an open slot **2105-B** facing upward through a length of one side of the peripheral side member **2100B** to align with the notch **3005-1**. The open slot **2105-B** provides an open space for laying a pair of fiber cables **2010AB** which respectively packages optical fibers out of the optical-electrical sub-module in the sub-assembly **2000A** and **2000B**. Similarly, another pair of fiber cables **2010CD** also packages optical fibers out of the sub-assembly **2000D** and sub-assembly **2000C** and is laid in the open space provided by the open slot **2105-C** aligned with the notch **3005-2**.

Referring to FIG. 5 and FIG. 6, as the sub-assembly **3000A** is assembled in the packaging assembly **5000**, top surfaces of the lid members (e.g., **2200A**) of four sub-assemblies (e.g., **2000A**) are mechanically pressed in a good thermal contact against a bottom surface of the top plate member **3020** in the packaging assembly **5000**. In an embodiment, as shown in FIG. 5, a top side of the top plate member **3020** is configured with a heatsink having a plurality of fin structures **3021** extended vertically. The height of the plurality of fin structures are designed to help release module heat with a sufficiently high efficiency. Optionally, a thermal pad (not shown) can be inserted between the top surface of the lid members and the bottom surface of the top plate member **3020** to enhance the thermal conductivity. The heatsink is configured to release the heat generated by the four sub-modules in the sub-assembly **3000A** in which each sub-module contains 4 CWDM lasers and multiple pre-packaged CMOS chips like the driver chip **150** and TIA chip **140** and DSP chip **2030**. Mechanically, the top plate member **3020** is pressed by several spring-loaded compression pins **3030** with threaded head applied from the top side to lock in respective sockets **3063** with the backplate member **3060** in the package assembly **5000**.

Referring to FIG. 7, the sub-assembly of the sub-module **2000A** includes a case having a top lid member **2200A** covering a peripheral side member **2100A** located around a peripheral boundary region on top of a sub-module substrate **2300A** which is served as a bottom member for the sub-assembly **2000A**. Optionally, the sub-assembly **2000A** is a quadrant portion fitted in one of four window structures (e.g., **3008A**) of the package sub-assembly **3000A**. Optionally, the peripheral side member **2100A** includes at least an open slot **2105-A** for laying at least a fiber cable **2010A** for optical input/output fibers of the optical-electrical sub-module in the sub-assembly. Optionally, a top surface **2201A** of the lid member **2200A** may be attached with a thermal pad (not shown) for enhancing heat release efficiency of the sub-assembly **2000A**. Optionally, the sub-module substrate **2300A** also is structured to allow heat being conducted effectively through itself.

In one embodiment, as illustrated in FIG. 7, the sub-module packaged in the sub-assembly **2000A** includes a SiPho chip packaged on a silicon-photonics substrate **100** which is mounted on a top side of the sub-module substrate **2001A**. The SiPho chip **100** is substantially the same as one

die formed on a SOI wafer **10** using wafer level assembly process as shown in FIG. 3. Referring to FIG. 7, the SiPho chip **100** includes a driver chip **150** and a replicate driver chip **150'**, a TIA chip **140** and a replicate TIA chip **140'**, and four laser chips **110**, all flip-mounted on top of the same silicon-photonics substrate **100**. Some dummy chips (not shown) and field-effect transistor devices **145** can also be mounted on top of the same silicon-photonics substrate **100**. The SiPho chip includes a transmitter unit configured to generate multi-channel optical signals from the four laser chips which are modulated by four modulator devices driven by the driver chip based on data received via an electrical interface block. The multi-channel optical signals are transmitted to an optical transmit path coupled to an optical interface block to output a multiplexed optical signal.

In the embodiment, the same SiPho chip also includes a receiver unit configured to use a set of photodetectors to detect multi-channel optical signals received in an optical receive path and demultiplexed in the optical interface block from an incoming multiplexed optical signal and use the TIA chip to convert the detected multi-channel optical signals to current signals which are digitized and processed in the electrical interface block before being delivered as N to N lanes of digitized signals for electrical host including an optical transmit path and an optical receive path in the same silicon photonics substrate **100**. One driver chip **150** and one TIA chip **140** in the SiPho chip are involved in handling transmission of four light signals from the four laser chips to the optical transmit path and detecting four incoming light signals from the optical receive path. Another driver chip **150'** and another TIA chip **140'** are separately involved in handling transmission of four replicate light signals from the four laser chips to the optical transmit path and detecting four additional incoming light signals from the optical receive path. These TIA/Driver chips in each SiPho chip of the packaged sub-assembly **2000A** are configured to handle reception and transmission of light signals in two replicate sets of 4 CWDM channels with respective wavelengths centered at 1270 nm, 1290 nm, 1310 nm, and 1330 nm. Optionally, the electrical interface block comprises a digital signal processing (DSP) chip **2030** configured to process N to N Lanes of digitized signals with a data rate of 25 Gbit/s per lane. Optionally, the electrical interface block comprises a digital signal processing (DSP) chip **2030** configured to process N to N Lanes of digitized signals with a data rate of 50 Gbit/s per lane. Optionally, the electrical interface block comprises a digital signal processing (DSP) chip **2030** configured to process N to N Lanes of digitized signals with a data rate of 50 Gbit/s per lane. Optionally, the electrical interface block comprises a replicate digital signal processing (DSP) chip **2030'** and a microcontroller chip **2040**.

Additionally referring to FIG. 7, disposed along one side of the SiPho chip on the silicon photonics substrate **100**, a PLC block **200** is also mounted on the sub-module substrate **2300A**. The PLC block **200** includes one or more multiplexers and demultiplexers in PLC-based waveguide formed on a glass or sapphire substrate for guiding light waves to an optical output port and from an optical input port of the sub-assembly **2000A** by coupling light signals between the PLC block **200** and input/output optical fibers. The input/output optical fibers per one sub-assembly are packaged in one fiber cable **2005-1**.

Furthermore referring to FIG. 7, disposed along another side of the SiPho chip on the silicon photonics substrate **100**, one or more ASIC chips, for example, digital signal processing (DSP) chip(s) **2030(2030')**, can be flip-mounted on the same sub-module substrate **2300A**. Each DSP chip **2030**

or **2030'** is configured in an electrical interface block to support functions of one TIA chip **140** and one driver chip **150** for processing or modulating optical/electrical signals involving a 4-ch CWDM optical transmit/receive path or one replicate TIA chip **140'** and one replicate driver chip **150'** for processing or modulating optical/electrical signals involving a replicate 4-ch CWDM transmit/receive path. Moreover, a microcontroller chip **2040** is also flip-mounted to the sub-module substrate **2300A** next to the replicate DSP chip **2030'** and configured in the electrical interface block to support operation of the DSP chip or replicate DSP chip as well as the operation of SiPho chip. Referring to FIG. 7, the DSP chips **2030** (**2030'**), or microcontroller chip **2040** are mounted onto a front side of the sub-module substrate **2300A** via multiple conductive bonding bumps **2108**. Optionally, the sub-module substrate **2300A** also provides its bottom side for mounting additional functional chips for utilizing the substrate more efficiently to enhance performance of the light engine. For example, an ASIC chip **2050** for analog controls for the laser and modulator is mounted at the bottom side of the sub-module substrate **2300A** via multiple bumps **2109** based on through-substrate vias.

Referring to FIG. 5 and FIG. 6, the sub-assembly **3000A** of the in-packaged light engine **3000** is received by or disposed in a socket frame member **3010** from its top side. An interposer plate **3040** is configured to be disposed between bottom side of the four sub-module substrates (e.g., **2300A**) of the sub-assembly **3000A** and a top side of a module substrate **3050**. Optionally, the four sub-module substrates **2300A** through **2300D** (see FIG. 6) may be considered as one common substrate. Optionally, the module substrate **3050** is configured to serve as a line card including relevant electrical connection circuits in a printed circuit board (PCB) to the host. Optionally, the module substrate **3050** is a part of a larger line card by itself. The PCB associated with the module substrate **3050** is configured with integrated circuits with a line interface connecting via the four sets of conducting bump contacts to the four sub-assemblies of the optical-electrical sub-modules and configured as a line card with a host interface for connecting the multi-channel light engine to a data center and with an external power interface for accessing external power supply. Optionally, the interposer plate **3040** includes four groups of patterned through-substrate vias (TSVs) (e.g., **3044A**) designed for coupling the bottom sides of four sub-module substrates **2300A** through **2300D** respectively for the four optical-electrical sub-modules **2000A** through **2000D**.

Optionally, the interposer plate **3040** is a passive interposer provided with four quadrant grids of conductor-filled through-substrate via (TSVs) bumps respectively formed on four quadrant regions of the interposer plate projected to the four sub-module substrates. For example, the quadrant grid of TSV bumps **3044A** is designed for forming electrical connections between the sub-module substrate **2300A** to direct bonding interconnects (DBI) contacts **3052A** in a corresponding quadrant region of the module substrate **3050**. Optionally, each quadrant grid of TSV bumps (e.g., **3044A**) is provided to surround a quadrant hollow region (e.g., **3042A**) of the interposer plate **3040** to yield the space for optional ASIC chip (e.g., **2050** in FIG. 7) mounted on the back side of the sub-module substrate (e.g., **2300A**).

Optionally, the interposer plate **3040** is an active interposer that contains four quadrant grids of TSV bumps to connect IOs and supply as well as to provide active regions with embedded circuit devices to pass electrical signals using buffers between two DBI contacts. Optionally, the

interposer plate **3040** is a 2.5D silicon interposer. Optionally, the interposer plate **3040** is a 3D silicon interposer.

Referring to FIG. 5, the module substrate **3050** includes several alignment through-holes **3051** aligned with similar alignment through-holes **3041** in the interposer plate **3040** and that **3011** in the socket frame member **3010**. The backplate member **3060** includes an alignment pin **3061** configured to pass through those alignment through-holes **3051**, **3041**, and **3011** for properly stacking these assembly members together. The module substrate **3050** also has several through-holes **3053** allowing the compression pins **3030** to pass for locking all parts in the package assembly **5000** with the backplate member **3060**. The backplate member **3060** includes several opened window regions (e.g., **3062A**) designed to provide space for mounting additional chips on the backside of the module substrate **3050**. Optionally, these window regions provide better thermal conductivity for the package assembly **5000**. The backplate member **3060** has several threaded holes **3063** allowing the corresponding compression pins **3030** with threaded head to lock in there so that the package assembly **5000** is tightly assembled.

In still another aspect, the present invention provides a light engine chiplet that integrates a silicon photonics (SiPho) chip with opto-electrical interfaces to form a multi-channel transceiver in a compact package on a single substrate. Optionally, the light engine chiplet is provided as one integrated optical-electrical module outlined in FIG. 1 to receive data in 25G or 50G or 100G for driving 4-wavelength lasers to achieve N electrical to N optical lanes communication. Optionally, the light engine chiplet is configured as an optical-electrical transceiver integrating 4 lasers with a driver module and a TIA module on a silicon photonics substrate to provide 4 CWDM channels plus 4 replicate channels coupled to a PLC block as shown in FIG. 2. Optionally, the light engine chiplet is provided as a quadrant sub-module on a same module substrate of an in-packaged optical-electrical module **3000** in FIG. 4. Alternatively, the in-packaged optical-electrical module can assemble two light engine chiplets or six light engine chiplets depending on different capacities, reach ranges, and bandwidth requirements for different high-speed data communication applications.

FIG. 8 shows an evolution of a light engine chiplet with improved chip data capacity and reduced lateral dimension according to an embodiment of the present invention. This diagram is merely an example, which should not unduly limit the scope of the claims. One of ordinary skill in the art would recognize many variations, alternatives, and modifications. Referring to part A of the FIG. 8, the light engine chiplet is substantially the same as an optical-electrical sub-module **2000A** disposed as a quadrant of the in-packaged optical-electrical module **3000** shown in FIG. 4. As described in FIG. 4, the light engine chiplet **2000A** includes a SiPho chip **100** which integrates four laser chips **110** with a driver chip **150** and a TIA chip **140** as well as a replicate driver chip **150'** and a replicate TIA chip **140'** all mounted on a silicon photonics substrate and together functioned as a multi-channel optical-electrical transceiver. The SiPho chip **100** is mounted on a sub-module substrate shared with a DSP chip **2030** and a microcontroller chip **2040** as well as a replicate DSP chip **2030'** and a PLC block **200**. In the silicon photonics substrate, several waveguide-based 1-to-2 optical splitters are built in to split each laser light from a respective one of the four laser chips **110** into two branches, providing 4 replicate channels for respective 4 CWDM channels with center wavelengths at 1270 nm, 1290 nm,

1310 nm, and 1330 nm, respectively. Depending on the DSP chips and microcontroller chip and associated electrical host data input and host interface setting, a data rate per channel can be provided with 25G using NRZ modulation protocol to modulate each of the four lasers **110**, yielding $25\text{G}\times 8=0.2$ Tbit/s per light engine. If a data rate per channel is given by 50G using PAM-4 modulation protocol to modulate each laser, it gives 0.4 Tbit/s per light engine with 8 optical lanes. Optionally, the light engine chiplet **2000A** can be provided as one independent unit assembled within a four-unit optical-electrical module **3000** as shown in FIG. 4.

Referring to part B of the FIG. 8, the light engine chiplet **4000A** is still a multi-channel transceiver configured with a substantially same setting as the light engine chiplet **2000A** in chip layout, chip size, laser driving, silicon photonics substrate and waveguide design, and sub-module substrate design. The improvement lies in upgradation of corresponding chips and laser modulation scheme therein. For example, DSP chip **4030**, **4030'**, microcontroller chip **4040**, driver chip **300**, TIA chip **280**, replicate driver chip **300'** and replicate TIA chip **280'**, and host data rate loaded via electrical host interface are upgraded to 100G per channel using PAM-4 modulation protocol with a rate of $56\text{Gbaud}/\lambda$ so that the data capacity per light engine chiplet is doubled to 0.8 Tbit/s. The PLC block **200** and laser chips **110** can be substantially no change versus those in the light engine chiplet **2000A**. Optionally, the light engine chiplet **4000A** can be a quadrant of four-sub-module assembly independently operated in an optical-electrical module. Optionally, the light engine chiplet **4000A** can be provided as one independent unit assembled within a multi-unit optical-electrical module.

Referring to part C of the FIG. 8, in an embodiment, the light engine chiplet **8000** is reconfigured to reduce the package size substantially. An integrated CMOS chip **4340** and a newly designed SiPho chip are mounted on a smaller sub-module substrate in a reduced lateral dimension. Optionally, the light engine chiplet **8000** are provided in a lateral dimension of $10\text{ mm}\times 10\text{ mm}$ or less, substantially reduced from $25\text{ mm}\times 25\text{ mm}$ for the light engine chiplet **2000A** or **4000A**. In the embodiment, an integrated processing chip **4340** combines the DSP chip (e.g., **4030**) with the microcontroller chip (e.g., **4040**) to provide electrical host interface for the multi-channel transceiver. Additionally, the driver chip(s) are alternatively integrated into the CMOS circuit (not visible in the figure). The TIA chip(s) **480** (**480'**) have reduced sizes and are mounted on the newly designed SiPho chip on silicon photonics substrate **100'**.

Optionally, the SiPho chip of the light engine chiplet **8000** still integrates 4 laser chips **110'** on the silicon photonics substrate **100'**. But all laser chips are redesigned for emitting laser light with higher power. In the silicon photonics substrate **100'**, several waveguide-based 1-to-4 optical splitters can be formed to yield 4 replicate channels per one laser. Thus, each light engine chiplet **8000** can provides 16 channels or 4 sets of 4 CWDM channels to yield total 1.6 Tbit/s capacity if each channel is provided with 100 Gbit/s capacity under PAM-4 56Gbaud data modulation. Optionally, the high-power laser chips could be mounted on the silicon photonics substrate **100'**, or mounted externally and coupled into the waveguide-based devices in the silicon photonics substrate **100'**. Optionally, the SiPho chip of the light engine chiplet **8000** can integrate 8 laser chips when each laser chip is coupled to a 1-to-2 optical splitter. Optionally, the light engine chiplet **8000** still just integrate 4 laser chips **110'** on the silicon photonics substrate **100'** respectively coupled to four 1-to-2 optical splitters, giving 8 channels per chiplet.

Optionally, a next generation modulation scheme using PAM-6 or PAM-8, or using higher Gbaud rate under PAM-4, a 200 Gbit/s per wavelength capacity can be provided so that each light engine chiplet in a $10\text{ mm}\times 10\text{ mm}$ package can still yield 1.6 Tbit/s capacity. Optionally, coherent polarized light signal can be implemented to provide directly 200 Gbit/s or 400G it/s per wavelength in bandwidth to allow each chiplet to support extra-high data rate communication. Optionally, the light engine chiplet **8000** can be provided as one independent unit assembled within a multi-unit optical-electrical module or directly integrated on a same switch substrate with multiple chiplets and a switch processor.

Referring to part C of FIG. 8, the smaller sub-module substrate of the light engine chiplet **8000** forces some changes in the packaging assembly of all optical-electrical components therein. For example, the lateral dimension of the chiplet **8000** can be reduced to $10\text{ mm}\times 10\text{ mm}$ or smaller. FIG. 9 is an exploded view of a sub-assembly of a light engine chiplet with reduced lateral dimension according to an embodiment of the present invention. This diagram is merely an example, which should not unduly limit the scope of the claims. One of ordinary skill in the art would recognize many variations, alternatives, and modifications. Referring to FIG. 9, the packaging assembly **8000A** of the light engine chiplet includes a vertical stacking assembly of multiple chips on separate component substrates unlike the light engine chiplet **2000A** for keeping the CMOS chips, SiPho chip, and PLC block on a single sub-module substrate **2300A** (see FIG. 8). As an example, the packaging assembly **8000A** includes a lid member **8100** configured with a top plate **8101** connected to four side walls **8105**. At least one side wall **8105** includes an opening port **8110** configured to allow an optical connector (see FIG. 10 below) to plug in. The lid member **8100** also includes an optical connector interface structure (not visible) under the top plate **8101** coupled to the open port **8110** to allow at least one optical output and one optical input to be aligned with the respective pathways of the optical connector. Optionally, the optical connector interface is a parallel fiber interface. Optionally, the lid member **8100** is also made as a heat sink. Optionally, the top plate **8101** can be made by a high-thermal-conductivity material to serve as the heat sink for efficiently transfer heat out of the packaging assembly **8000A**. Optionally, additional thermal conductive structure is fabricated on top of the top plate **8101** to serve as a heat sink that fit in various systems such as optical switch module with co-packaged light engines in a rack chassis.

Referring to FIG. 9, the light engine chiplet in the packaging assembly **8000A** includes a first component substrate **8200** integrating an application-specific integrated circuit (ASIC) chip including a digital signal processing (DSP) chip, optionally a microcontroller chip, and host/line interface IC in a CMOS platform (e.g., 5 nm process). The DSP chip is at least configured to serve as a digital signal processing interface of the light engine functioned as an optical-electrical transceiver. A host interface integrated in the first component substrate **8200** is configured to perform data interconnect operation with an extra-short reach (XSR) or equivalent protocol to interact with system processor or electrical host. A line interface integrated in the first component substrate **8200** is configured to support PAM optical reach (POR) control of the light engine operation. Optionally, the DSP chip also includes Physical Code Sublayer (PCS) or Physical Medium Attachment (PMA) layers for data encoding and decoding or many other digital signal processing operations. Optionally, the first component substrate **8200** is disposed as a top die of the stack-up compo-

ment substrates (dies) at a nearest position under the lid member **8100**. Optionally, the first component substrate **8200** also integrates modulator driver and microcontroller directly into the DSP chip. Optionally, the DSP function in the ASIC chip is incorporated to a system processor and the first component substrate **8200** only retains integrated modulator driver and transimpedance amplifier function. Optionally, the ASIC chip includes SerDes chip for coding and encoding data through the DSP interface.

Referring to FIG. 9, the light engine chiplet in the packaging assembly **8000A** includes a second component substrate **8300** integrating an application-specific integrated circuit (ASIC) control chip and a third component substrate **8400** integrating a TIA chip, both being disposed below the first component substrate **8200**. Optionally, the TIA chip is coupled to bottom conductive contacts of the first component substrate **8200** via a set of bumps **8410** on the third component substrate **8400**. The ASIC control chip is configured to couple to bottom of the first component substrate **8200** via another set of bumps **8310** on the second component substrate **8300**. The second component substrate **8300** and the third component substrate **8400** (or may be a combined substrate) thus are disposed as a middle die under the top die of the stack-up component substrates in the packaged assembly **8000A**. Optionally, the TIA chip is reduced in size and mounted or integrated into a silicon photonics (SiPho) chip below and the ASIC control chip in the second component substrate **8300** may be integrated into the DSP chip in the top die in the first component substrate **8200**. Optionally, the TIA chip may be also integrated into the DSP chip in the top die associated with the first component substrate **8200**. In this case, the middle die of the stack-up can be eliminated.

Referring to FIG. 9, the light engine chiplet in the packaging assembly **8000A** includes a fourth component substrate **8500** made by a silicon photonics substrate integrating various Si or SiGe-based waveguide devices such as optical modulators and photodetectors. Optionally, the fourth component substrate **8500** by itself forms a SiPho chip as an individual die in the stack-up. Optionally, the SiPho chip is coupled via a set of bumps **8510** to the ASIC control chip in the second component substrate **8300** for controlling the operation of DSP chip or TIA chip. The SiPho chip is also coupled via a set of bumps **8512** to the TIA chip in the third component substrate **8400** for passing the incoming optical signals to the photodetectors which generate photocurrent signals for the TIA chip. Optionally, the SiPho chip in the fourth component substrate **8500** also directly integrates multiple, e.g., four, laser chips as light sources to provide multiple optical channels of the optical-electrical transceiver for optical data communication, a designated function of the light engine chiplet. Optionally, the laser chips, especially, high-powered laser chips can be disposed outside the packaging assembly **8000A**. Optionally, the fourth component substrate **8500** is disposed as a bottom die under the middle die more distal to the top die in the stack-up in the packaging assembly **8000A**. Optionally, as the middle die is partially absorbed into either the top die or bottom die, for example, the ASIC control chip is incorporated into the DSP chip and the TIA chip is reduced in size and mounted or embedded into the SiPho chip, the bottom die associated with the fourth component substrate **8500** may be directly coupled with the top die associated with the first component substrate **8200**. Alternatively, the first component substrate **8200** is disposed as a bottom die while the fourth component substrate **8500** can be disposed as a top die in the stack-up in the packaging assembly **8000A**.

Referring to FIG. 9, the light engine chiplet in the packaging assembly **8000A** includes a sub-module substrate **8600** served as a bottom member of the packaged assembly **8000A**. The sub-module substrate **8600** is provided as a micro land grid array (LGA) substrate which includes a matrix array of conductive socket contacts **8610** convenient for chip testing and surface-mount packaging assembly. Optionally, the micro-LGA substrate is also designated for mounting the light engine chiplet onto a module substrate by connecting the conductive socket contacts to a printed circuit board line card designed for being used in an optical network system in a rack chassis. Optionally, the sub-module substrate **8600** is a 2.5D substrate having through-vias to connect all active components without any wire bonding. Optionally, power regulators and decoupling capacitors may be integrated into ASIC chips such as the digital signal processing chip as no power supplies are provided in the micro-LGA substrate for the light engine chiplet in this compact packaging assembly **8000A**. Optionally, all components in the packaging assembly **8000A** as described above has a lateral dimension substantially limited by the sub-module substrate **8600**. It is desired to push the lateral dimension smaller and smaller except that high-powered laser may have to be mounted externally instead of integrated in the SiPho chips therein. In an example, the lateral dimension is as small as 10 mm×10 mm.

Referring to part C of FIG. 8 and FIG. 9, the sub-module substrate **8600** for supporting the light engine chiplet **8000** is reduced in size comparing to that **2300A** for supporting the light engine **2000A** or **4000A**. In these embodiments, the sub-module substrate, for example, a dimension of the sub-module substrate is only 10 mm×10 mm. The substrate with such a small dimension may not have room for mounting a PLC block like one PLC **200** in the light engine chiplet **2000A** or **4000A**. The PLC block containing at least a multiplexer and a demultiplexer in planar light circuit form is served as a key component of an optical line interface that needs to be coupled with the SiPho chip in the light engine chiplet operated as a multi-channel optical-electrical transceiver. Unlike the light engine (**2000A** or **4000A**) packaged on a larger sub-module substrate, FIG. 10 shows, in a perspective view at bottom, that the light engine chiplet of FIG. 9 is configured to couple with an external PLC block integrated in an optical connector according to an embodiment of the present invention. This diagram is merely an example, which should not unduly limit the scope of the claims. One of ordinary skill in the art would recognize many variations, alternatives, and modifications. In an embodiment, as shown in FIG. 10, a PLC block **8700** is disposed outside the packaging assembly **8000A** of the light engine chiplet. The PLC block **8700** includes at least a multiplexer **8710** and a demultiplexer **8720** formed as planar waveguide devices on a glass substrate. One end of the PLC block **8700** is coupled to a coupling head **8910** with two alignment pins **8915** being plugged into two sockets in the optical port **8110** and allowed several on-board fibers (not shown) to couple with the multiplexer **8710** and a demultiplexer **8720** and with respective output/input waveguides in the SiPho chip in the light engine chiplet. Another end of the PLC block **8700** is coupled to an optical adaptor **8800** which aligns the planar waveguide devices in the PLC block **8700** to corresponding in/out optical fibers. A fiber cable **8900** is configured to pack all in/out optical fibers together and connected to an optical connector for connecting to an optical network system.

FIG. 10 also shows, in a cross-section view at top, that the packaging assembly **8000A** of the light engine chiplet is

clamped in a socket base member **8010**. As shown, under the lid member **8100**, a stack-up of multiple dies are assembled together including a DSP die plus host interface in the first component substrate **8200** on the top, controller chip in a second component substrate **8300** and a TIA chip in the third component substrate **8400** side-by-side in the middle, and a SiPho die in the silicon photonics substrate **8500** at the bottom on the sub-module substrate **8600** which serves as a bottom member. The socket base member **8010** includes several bottom notches **8015** (seen in the perspective view) configured to allow a shaped metal wire **8020** to clamp the packaging assembly **8000A** with spring force onto the socket base member **8010**. The socket base member **8010** also includes alignment pins **8012** (seen in the cross-section view) at the bottom thereof used for disposing the clamped packaging assembly of the light engine chiplet onto a pre-defined location in a module substrate (e.g., a switch substrate). The socket base member **8010** also includes a plurality of thru-vias configured to have conductor pins or wires **8018** installed for forming proper electrical connection between the packaging assembly **8000A** of the light engine chiplet and a module processor/controller (not shown) on the same module substrate. Optionally, the lateral dimension of the socket base member **8010** holding the packaged assembly **8000A** is substantially 10 mm×10 mm.

In still another aspect, the present disclosure provides a co-packaged optical module with a switch processor and multiple light engine chiplets commonly mounted on a switch substrate for extra short reach interconnect or equivalent protocol in high-speed data communication. With obvious benefit of reduced interconnect loss (<10 dB) in sight, optics based on silicon photonics platform is brought closer and closer to a switch processor for meeting demands on increasing data rate in high-speed data communication. As shown in FIG. 9 and FIG. 10, a light engine configured as a multi-channel optical-electrical transceiver can be integrated on a compact sub-module substrate based on 2.5D LGA in a chiplet packaging assembly. An external PLC block can be provided in an integrated optical connector to couple with on-board fibers connected to SiPho chip in the light engine. Optionally, the light engine can use host FEC to draw control signals without using gear box or retimer module. Such light engine chiplet packaged as shown in FIG. 8 and FIG. 9 can be operated independently as multiple replicable units for providing desired number of optical signal lines or channels needed for Ultra-Short-Reach (USR) or Extra-Short-Reach (XSR) or equivalent protocol in electrical host interconnect operation via a single switch processor to communicate with multiple hosts and lines in one modular setting.

FIG. 11 is a perspective view of a co-packaged optical module of a switch processor mounted with multiple light engines commonly on a switch substrate for extra short reach or equivalent protocol in data communication according to an embodiment of the present invention. This diagram is merely an example, which should not unduly limit the scope of the claims. One of ordinary skill in the art would recognize many variations, alternatives, and modifications. As an embodiment shown in FIG. 11, the co-packaged optical (CPO) module **9000** is provided by integrating one switch processor **9100** with multiple packaged light engine chiplets **9201** commonly on a switch substrate **9001**. In an embodiment, the switch processor **9100** is mounted in a central site of the switch substrate **9001** while all the multiple packaged light engine chiplets **9201** are substantially evenly distributed at periphery sites on the switch substrate **9001** surrounding the switch processor **9100**.

Optionally, the switch substrate **9001** is in a square shape having four peripheral sides for mounting equal-number of the packaged light engine chiplets **9201** per side. Each packaged light engine chiplets **9201** is substantially the same as one packaging assembly **8000A** of a multi-channel optical-electrical transceiver provided in FIG. 9 being clamped in a socket base member **8010** as shown in FIG. 10. Each clamped chiplets is mounted into the switch substrate **9001** by using a couple of alignment pins (**8012**, see FIG. 10) at bottom of the socket base member **8010**.

In a specific embodiment, each packaged light engine chiplets **9201** includes an optical connector port for plugging-in an optical connector head that is coupled to a PLC block to serve its optical line interface for the multi-channel optical-electrical transceiver. Optionally, each chiplet integrates four laser chips in a silicon photonics substrate to provide four CWDM wavelengths corresponding to four optical channels of the optical-electrical transceiver. Optionally, four 1-to-2 splitters can be added to split each laser light to two to provide four more replicate optical channels with the same four CWDM wavelengths. Optionally, each chiplet can integrate four more laser chips or choose four 1-to-4 splitters for four high-powered laser chips to yield 8 or 16 channels. Each light engine chiplet can fully be operated independently with its own controller and driver. Thus, in the co-packaged optics configuration as shown in FIG. 11, one switch processor can be co-packaged with some predetermined numbers of light engine chiplets on the same switch substrate depending on designed processor with maximum die size and data handling capacities in one co-packaged switch module in a rack chassis for different applications. Referring to the example shown in FIG. 11, one switch processor **9100** is co-packaged with 8 light engine chiplets **9201** on each of peripheral sides of a switch substrate **9001**. If each light engine chiplet has 8 channels with 200 Gbit/s per channel or 16 channels with 100 Gbit/s per channel, the single packaged chiplet **9201** provides 1.6 Tbit/s capacity and the co-packaged optical (CPO) module **9000** is enabled for 51.2T operation. In an alternative example, one switch processor can be co-packaged with one light engine chiplets on each of peripheral sides of the switch substrate for switch and optical interconnect, then the CPO module is enabled for 6.4T operation. Optionally, a CPO module can be enabled for 25.6T operation by co-packaging one switch processor with four light engine chiplets on each of peripheral sides of the switch substrate for switch and optical interconnect.

In an embodiment, a goal of moving optical-electrical module closer and closer to the switch processor from using pluggable optical module with gear box or retimer to on-board in-package optics and further to the co-packaged optical module that eliminates the gear box or retimer is to reduce power loss (from 20 to 35 dB down to <10 dB) depended on the range of interconnect and substantially reduce power consumption per bit from about 5.0 pJ/bit to <1.8 pJ/bit. Since the switch processor has its own limits on package size especially when its operation capacity is increased to 51.2T generation, a requirement for smaller total module package size and push for smaller distance between the switch processor and each light engine co-packaged naturally put limitations on both the size of switch substrate and the size of light engine (or sub-module) substrate.

FIG. 12 shows a top view of a schematic co-packaged switch module co-packaged with 32 packaged light engine chiplets (average 8 chiplets per side) with 1.6T capacity per light engine commonly on a 100 mm×100 mm switch

substrate. The switch processor has a reticle size of about 800 mm² for achieving the 51.2 Tbit/s total throughput in single die to be compatible with the 32 packaged light engines each independently with 1.6 Tbit/s capacity. To fit in the length of 100 mm for every peripheral edge, each packaged light engine chiplet is limited to an area of about 10 mm×10 mm. Referring to FIG. 9 and FIG. 10, each light engine chiplet is in-packaged with minimum functionality of digital processing/host interface with enabled Extra-Short-Reach (XSR) or Physical Code Sublayer (PCS) or Physical Medium Attachment (PMA) layers in the DSP chip to reduce the sub-module substrate to 10 mm×10 mm. Optionally, the driver/TIA chips also are reduced their footprint in the chiplet with a stack-up mounting scheme or are incorporated completely into the DSP chip. Depending which chiplet among each peripheral side of the 100 mm×100 mm switch substrate, the maximum distance from the switch processor die edge to furthest light engine chiplet is smaller than 50 mm. As the result, a most-compact switch module with 51.2Tbit/s total throughput based on the 10 mm×10 mm 1.6 Tbit/s light engine is shown in FIG. 11 and FIG. 12. In general, for a given total data throughput of a co-packaged switch module with a configuration of a plurality of chiplet dies surrounding a main processor die in the central location, each chiplet die is preferred to have a minimum die size to allow a maximum number of chiplet dies disposed densely on the module substrate with a distance of any chiplet die from the main die as small as possible for extra-short-reach or equivalent protocol in data interconnect operation. Also, each chiplet die is preferred to have higher data capacity so that smaller numbers of chiplet dies are needed.

Note, for each 10 mm×10 mm 1.6T light engine, 4 (or even 8) laser chips can still be integrated inside the chiplet package (FIG. 9 and FIG. 10) to provide 4 (or 8) CWDM wavelengths. While a compact multiplexer/demultiplexer optical interface is developed to be integrated into an optical connector that plugs into an optical port of each light engine chiplet to save space. As shown in FIG. 11, each light engine chiplet 9201 has its optical port facing outward to allow the optical connector to be plugged-in (see FIG. 10). Optionally, 4 remote high-power laser sources are provided externally via 4 fibers. Optionally, each laser can be split 8 ways to provide 32 100G/λ lanes. Optionally, each laser can be split 4 ways to provide 16 200G/λ lanes. In these options, 3.2 Tbit/s per light engine can be enabled.

FIG. 13 is a schematic diagram illustrating evolved integration schemes of moving light engines closer to a switch processor for reducing interconnect reach distance in high-speed data communication applications according to some embodiments of the present invention. This diagram is merely an example, which should not unduly limit the scope of the claims. One of ordinary skill in the art would recognize many variations, alternatives, and modifications. In some scenarios (A and B) of the embodiment, the switch processor, no matter it is configured for PAM backplane reach (PKR) operation or extra-short-reach (XSR)/short reach (SR)/medium reach (MR) operation with each light engine enabled with 100 Gbit/s per wavelength in one optical lane, can be deployed alone on a switch substrate which is connected over a certain range of interconnect via gear box or retimer in-packaged with multiple light engines on a separate line card. Optionally, the multiple light engines are packaged four quadrants of optical-electrical sub-modules as shown in FIG. 4, FIG. 5, and FIG. 6 with each quadrant sub-module carrying 0.8 Tbit/s in 8 optical lanes. The certain range of interconnect includes long-range interconnect involving optical loss of 35 dB or less in the

scenario A, or medium-range interconnect involving optical loss of 25 dB or less, or short or extra-short range of interconnect involving optical loss of about 10 dB in the scenario B with each quadrant sub-module being improved to 1.6 Tbit/s in 8 optical lanes. The optical line interface can employ a PAM optical reach (POR) or equivalent protocol and the electrical host interface can include a PAM backplane reach (PKR) or equivalent protocol under a same setting of line/host interface scheme for the scenarios of A and B.

In some other scenarios (C through F) of the embodiment, the switch processor is co-packaged with multiple light engines in a much closer distance on a same switch substrate to form a co-packaged optical (switch) module which can be deployed to a network system in a single rack chassis. No gear box or retimer is required while host FEC is used in digital signal processing with 56 Gbaud electrical interface. Each light engine in the scenario C of the embodiment includes a silicon photonics chip packaged with a TIA chip and modulation driver chip and stacked up with a digital signal processing (DSP) chip above or under the silicon photonics chip. Optionally, the DSP chip is configured with a host interface, PCS/PMA layers, and a line interface for PAM optical reach operation. The switch processor in this scenario is configured with DSP interface for 51.2T operation (see FIG. 11) disposed to a central area of a 100 mm×100 mm switch substrate with each of 32 light engines (each of 1.6 Tbit/s capacity) being distributed around peripheral regions of the switch substrate. Each light engine is limited in a packaged chiplet of 10 mm×10 mm carrying 1.6 Tbit/s (see FIG. 12) including 4 in-packaged lasers and an externally coupled multiplexer/demultiplexer optical interface integrated in an optical connector. The switch processor is connected with each of the 32 light engines with a maximum distance of <50 mm via in-substrate interconnect in the switch substrate, yielding a power loss of <10 dB and compatibility with the 51.2T extra-short-reach (XSR) or equivalent protocol in data interconnect operation designed for the switch processor. Optionally, the switch processor can be connected with 16 light engines of 3.2 Tbit/s capacity to have 51.2T total data throughput.

Alternatively, the scenarios D through F illustrate options of pushing the light engine closer and closer to the processor with switch substrate or light engine substrate sizes being adjusted depending on individual light engine chiplet die sizes. Each light engine chiplet is assumed to maintain 100 Gbit/s per wavelength in each optical lane. In a specific embodiment, the light engine in the scenario D includes a silicon photonics chip and transimpedance amplifier with externally coupled laser sources driven by analog driver and external multiplexer/demultiplexer optical interface to connect via on-board fibers to an optical connector, while eliminating retimer function within the light engine. Optionally, each light engine can be provided in a packaged chiplet form with a smaller individual die size. Optionally, the light engine includes an external SiGe-based modulation driver with relatively higher power consumption. Optionally, the light engine includes an external CMOS driver integrated in the switch processor to reduce the power consumption. The switch processor in the scenario D incorporates the DSP host interface only without FEC function while implementing PAM optical reach. Optionally, the switch substrate size can be reduced further depending on individual light engine die size and throughput setting per light engine. In an example, each light engine still provides 1.6 Tbit/s, thus, the switch module still needs 32 light engines to have 51.2 Tbit/s total throughput. In another example, each light engine is

expanded to 3.2 Tbit/s, the co-packaged switch module needs just 16 light engines to have 51.2 Tbit/s total throughput. As the result, a maximum distance between the switch processor and one of the multiple light engine chiplets co-packaged in the scenario D may be reduced further. In an example, the distance is smaller than 15 mm to push even lower optical power loss in the XSR interconnect operation.

Additionally, in the scenario E, the light engine includes a silicon photonics chip packaged with a TIA chip only while moving the modulation driver into CMOS chip associated with the switch processor. The individual die size may be further reduced as the lasers and optical interface can all be coupled externally. The switch processor in the scenario E incorporates the DSP host interface to interact with electrical host yet without FEC function and analog modulation driver to control laser signals while implementing PAM optical reach. As the result, a maximum distance between the switch processor and one of the multiple light engine chiplets co-packaged in the scenario E may be reduced even further. In an example, the distance is smaller than 5 mm to push even lower optical power loss in the extra-short-reach (XSR) or equivalent protocol in data interconnect operation and lower power consumption per module with the same 51.2 Tbit/s total throughput.

Furthermore, in the scenario F, the light engine is packaged by integrating the silicon photonics chip with a Serializer/Deserializer (SerDes) block and a TIA chip in the packaged chiplet. The SerDes block provides data transmission over a single line or a differential pair in order to minimize the number of I/O pins and interconnects. The data speed per line can be 56 Gb/s or 112 Gb/s. Optionally, the SerDes block includes digital encoding/decoding blocks. Accordingly, the switch processor in this scenario F employs Advanced Interface Bus (AIB) or parallel bus with packages to allow heterogeneous integration of multiple die into a single package to connect the analog front-end, signal pre-processing, to interface with Ser/Des block in each light engine chiplet for ultra-short-reach (USR) interconnect operation. In the scenario F, between the switch processor and the multiple light engine chiplets, an active Si interposer is inserted. The active Si interposer extends the concept of Chip-on-Wafer-on-Substrate (CoWoS) technology based on a 2.5D or 3D integrated circuit employing through-silicon via (TSV) interposer-based packaging technology to provide reticle matching the total module size and to hold the main switch processor die and all chiplet dies. Optionally, the active Si interposer contains a grid of TSVs to connect IOs and supply plus active regions to pass signals using buffers between two grids of conductive contacts formed according to the design of the main processor die and multiple dies of light engine chiplets as shown in FIG. 11 and FIG. 12. Optionally, the active Si interposer also can support connecting multiple main dies on one package substrate. With the active Si interposer, the light engine dies can be brought to the switch processor as close as <1 mm for establishing DSR-type interface.

FIG. 14 is an exploded view of all parts forming a packaged light engine chiplet as one of the multiple light engines in the co-packaged switch module according to an embodiment of the present invention. This diagram is merely an example, which should not unduly limit the scope of the claims. One of ordinary skill in the art would recognize many variations, alternatives, and modifications. As shown, the package includes an assembly of part A through part E as a packaged light engine chiplet ready for being mounted on the same switch substrate with multiple other light engine chiplets. The part A of the package is a

sub-assembly of the light engine chiplet, which is substantially same as the sub-assembly 8000A described in FIG. 9. In a perspective view of the sub-assembly, it shows a lid member 8100 on top attached on a sub-module substrate 8600 at bottom to enclose a light engine therein. Optionally, the sub-module substrate 8600 is a micro Land Grid Array (LGA) type substrate designated for mounting the light engine chiplet onto a module substrate. Optionally, the light engine enclosed in the sub-assembly is configured as a multi-channel optical-electrical transceiver including or coupling to multiple laser chips on a silicon photonics substrate to provide multiple CWDM wavelength channels. Optionally, the light engine enclosed the sub-assembly is configured to be operated with a data rate capacity of 1.6 Tbit/s or 200 Gbit/s for 8 optical lanes.

Referring to FIG. 14, the lid member 8100 is shown with more structural elements that play respective roles to be assembled with other parts in the package of the light engine chiplet. For example, the lid member 8100 includes at least two straight side edges 8105 on two opposing sides naturally connected a front edge with an optical port 8110 and a back edge. Each side edge 8105 stands vertically on a ledge structure, i.e., a flat horizontal portion 8107 joined with a smaller vertical portion 8108. The ledge structure can be utilized by other parts for fixing the sub-assembly in the package.

The part B in the package of FIG. 14 is an interposer pad 8120 configured to connect a micro LGA type substrate at its top side with a printed circuit board below. In the package of FIG. 14, the interposer pad 8120 with an array of patterned holes 8125 is inserted below the sub-module substrate 8600 to provide capability to mate and de-mate the light engine chiplet being surface-mounted on the co-packaged substrate or printed circuit board.

The part C in the package of FIG. 14 includes a plurality of connection pins 8018 with small pitch size and low profile to provide connection paths for electrical signals between the light engine and circuits in the switch substrate and other chips mounted on the switch substrate. The plurality of connection pins 8018 is arranged in a matrix array designed to match the interposer pad 8120 compatible for high-speed (56 Gbaud/s and higher) and high-power data communication. The matrix array of connection pins 8018 are respectively disposed at a matrix of through holes in the part E which is configured as a socket base member 8010 at the bottom of the package.

The part D in the package of FIG. 14 is a shaped metal wire 8020 for clamping the part A, i.e., a sub-assembly 8000A of the light engine chiplet, into the part E, the socket base member 8010. In particular, the socket member 8010 includes a flat plate 8011 with a matrix of through holes 8013 compatible with the LGA-type interposer pad 8120 for forming proper electrical connections with the LGA-type substrate 8600 of the sub-assembly 8000A. The matrix array of connection pins 8018 are disposed into respective through holes 8013 in the flat plate 8011 so that the interposer 8120 can be placed on top to form interconnect with respective electrical contacts at the bottom side the sub-module substrate 8600 as the sub-assembly of the light engine is disposed on the interposer 8120 in the socket base member 8010. In addition, the matrix array of connection pins 8018 also form respective conduction paths to connect the light engine with electrical contacts on a module substrate (such as the switch substrate 9001 in FIG. 11) in a co-packaged optical module (such as CPO module 9000 in FIG. 11).

In the embodiment, the shaped metal wire 8020 is a single wire shaped with at least a horizontal backside section 8026

extended to substantially entire length of the back wall of the socket base member **8010**, two bended back sections **8022** connected to respective ends of the horizontal backside section **8026**, two horizontal side sections **8027** respectively connecting the two bended back sections **8022** to two bended front sections **8021**. Each bended front section **8021** further is extended downward to a vertical section **8024** which is coupled to an end section **8025** with a length much shorter than entire length of the front wall bended from the vertical section **8024** to horizontal direction along the front wall of the socket base member **8010**.

The part E, i.e., the socket base member **8010**, is configured to have some slot/notch structures at both the front wall and back wall respectively matching the two bended front sections **8021** including the vertical section **8024** and the end section **8025** and two bended back sections **8022** including the horizontal backside section **8026**. A bottom notch (not visible in FIG. 14) formed in the back wall of the socket base member **8010** is designed to hold the horizontal backside section **8026** of the shaped metal wire **8020** so that the two bended back sections **8022** are fitted in respective two back slots **8016**. The bended front or back sections of the shaped metal wire **8020** may generate desired elastic forces depending on bending angle and mechanical tensile strength of the metal wire with a certain diameter. Accordingly, the two horizontal side sections **8027** are forced to land on the two flat horizontal portion **8107** of two side ledges of the lid member **8100** (provided that the sub-assembly **8000A** is disposed in the socket base member **8010** in the package of FIG. 14). Furthermore, the two bended front sections **8021** of the shaped metal wire **8020** connect to the two end sections **8025** respectively via two vertical sections **8024** so that the two end sections are respectively held by two bottom notches **8015** on the front wall of the socket base member **8010** to force the two horizontal side sections **8027** on the two flat horizontal portion **8107** of the lid member **8100** to clamp the sub-assembly (part A of FIG. 14) of the light engine chiplet in the socket base member **8010**.

Moreover, the socket base member **8010** includes a couple of registration pins **8012** designed to mate with a compatible registration holes in the module substrate or printed circuit board (such as a switch substrate **9001** in FIG. 11) to allow the packaged light engine chiplet being surface mounted in the co-packaged optical module. Optionally, the two registration pins **8012** are located at two diagonal positions at the bottom side of the socket base member **8010**. As the socket base member **8010** is mated with a sub-module site in the module substrate via the registration pins **8012**, the matrix array of connection pins **8018** also have their respective bottom contacts to form electrical connections between the light engine and the module substrate.

FIG. 15 shows a perspective view (part A) and a side view (part B) of the packaged light engine chiplet of FIG. 14 according to an embodiment of the present invention. This diagram is merely an example, which should not unduly limit the scope of the claims. One of ordinary skill in the art would recognize many variations, alternatives, and modifications. As shown in part A of FIG. 15, the packaged light engine chiplet **9200** is a package assembled all the parts A through E shown in FIG. 14. In particular, the shaped metal wire **8020** (see part D of FIG. 14) is applied to clamp the sub-assembly **8000A** (part A of FIG. 14) of the light engine into the socket base member (part E) by pressing the horizontal side section **8027** onto the flat horizontal portion **8107** of the ledge structure of the lid member **8100** and locking the end section **8025** into the front-wall bottom notch **8015**. Optionally, the front edge **8105F** of the sub-

assembly **8000A** of light engine chiplet includes an optical port **8110**. Optionally, the packaged light engine chiplet **9200** substantially the same as each of the multiple light engines **9201** co-packaged with a switch processor **9100** commonly on a switch substrate **9001** to form the co-packaged optical module **9000** of FIG. 11.

The part B of FIG. 15 shows a side view of the same packaged light engine chiplet **9200**. In the embodiment, the vertical section **8024** of the shaped metal wire **8020** is positioned slightly ahead of the front edge **8105F** to leave a gap **8029** between them. This design allows a releasing mechanism to be applied for optional releasing the sub-assembly **8000A** from the packaged light engine chiplet **9200** when the latter is one of multiple light engine chiplets **9201** disposed in the co-packaged optical module to mate with the module substrate via the couple of registration pins **8012**. In the side view shown in the part B of FIG. 15, two registration pins **8012** can be seen. Optionally, the couple of registration pins **8012** are positioned along a diagonal direction of the socket base member **8010**. Also, a plurality of conduction pins **8018** with respective bottom contacts can be seen in this side view diagram of the packaged light engine chiplet **9200** to form electrical connections between the light engine and the module substrate.

FIGS. 16A-16C show a method of releasing a sub-assembly from the packaged light engine chiplet of FIG. 15 according to an embodiment of the present invention. These diagrams are merely an example, which should not unduly limit the scope of the claims. One of ordinary skill in the art would recognize many variations, alternatives, and modifications. In a partial view of a co-packaged optical module as shown in FIG. 16A, multiple packaged light engine chiplets **9201** are mounted on a module substrate **9001** (see FIG. 11). Each packaged light engine chiplet **9201** includes a sub-assembly **8000A** loaded in a socket base member **8010** disposed along a peripheral edge of the module substrate **9001** with a front edge facing the peripheral edge as indicated by an optical port **8110**. As seen in FIG. 16A the socket base member **8010** of the packaged light engine chiplet **9201** is mounted in a corner site in the module substrate **9001**. Substantially like the light engine chiplet **9200** shown in FIG. 15, two end sections **8025** of a metal wire **8020** are locked respectively into two front-wall bottom notches **8015** to clamp the sub-assembly **8000A** in the socket base member **8010**. Optionally, the sub-assembly **8000A** can be released from the socket base member **8010** while the latter is still mated with the corner site in the module substrate **9001**.

In FIG. 16B, a removal tool **9300** is provided with two arms **9320** connected in a U-shape piece. Each arm **9320** has a head member configured as a top tip **9321** connected to a side tip **9324**. The top tip **9321** has an extra length beyond an end facet **9323** of the side tip **9324** and a height above the arm **9320**. The side tip **9324** has a length extended sideways at a same height from the arm **9320**. Optionally, the removal tool **9300** is configured to be applied to the front edge of a packaged light engine chiplet **9201** disposed in its mating site on the module substrate **9001** to release the sub-assembly **8000A** clamped to the socket base member **8010**. Optionally, the two arms **9320** are separated by a distance larger than a width of the optical port **8110** so that the two head members can be engaged directly with the front edge. As the removal tool **9300** is engaged along direction **1** toward the front edge of the chiplet **9201** to have the end facet **9323** against the front edge, the side tip **9324** is allowed to be inserted with an extra length against the vertical section **8024** into the gap **8029** (see part B of FIG. 15). At the engaged position, the top tip **9321** of the respective head

31

member has its bottom surface in touch with top surface of the lid member of the chiplet **9201**. Then, the removal tool **9300** is lifted upward along direction **2** from the joint part of the U-shape piece with the head member being substantially against the top surface and the side edge of the lid member of the chiplet **9201**. The lift motion allows the side tip **9324** to push the vertical section **8024** of the metal wire **8020** outward so that the end sections **8025** of the metal wire **8020** is released out of the locked position with the front-wall bottom notches **8015** of the socket base member **8010**. FIG. **16C** shows the released state of the metal wire **8020** with the end section **8025** being no longer locked with the front-wall bottom notch **8015**. The sub-assembly **8000A** of the light engine chiplet can then be released from the socket base member **8010** while the latter can remain being mated at a corresponding peripheral site of the module substrate **9001**.

While the above is a full description of the specific embodiments, various modifications, alternative constructions and equivalents may be used. Therefore, the above description and illustrations should not be taken as limiting the scope of the present invention which is defined by the appended claims.

What is claimed is:

1. A co-packaged optical module comprising:
 - a substrate;
 - a processor arranged on the substrate; and
 - a plurality of light engines mounted around the processor on the substrate using mounting assemblies configured to attach the respective light engines to the substrate, the light engines and the mounting assemblies disposed along a perimeter of the substrate, including at corners of the substrate;
 each of the mounting assemblies comprising a socket, a clamp clamping a corresponding one of the light engines into the socket, and a plurality of alignment pins for mechanically aligning the socket to a pre-defined location on the substrate, which alignment pins when mated with corresponding holes in the substrate cause peripheries of the mounting assemblies, including the light engines, the sockets and the clamps, to be flush with the perimeter of the substrate, and to cover the entire perimeter of the substrate end to end including at the corners of the substrate.
2. The co-packaged optical module of claim **1** wherein the clamp is a metal clamp that includes a metal wire shaped to have a perimeter less than a perimeter of the socket and greater than a perimeter of the light engines.
3. The co-packaged optical module of claim **1** wherein each of the light engines comprises a base substrate having electrical contacts, and wherein each of the sockets comprises a base member having an array of through holes, the co-packaged optical module further comprising:
 - an interposer arranged below the base substrate of each of the light engines, the interposer having an array of patterned holes aligned with the electrical contacts of the base substrate; and
 - an array of connecting pins having first ends extending through the patterned holes in the interposer and second

32

ends extending via the through holes in the base member of the socket, the connecting pins connecting the electrical contacts on the base substrate to electrical contacts on the substrate of the co-packaged optical module.

4. The co-packaged optical module of claim **1** wherein each of the light engines comprises:
 - a plurality of interconnected substrates arranged in a stack, each of the substrates comprising circuits configured to process electrical signals;
 - a silicon photonics substrate connected to one of the substrates in the stack, the silicon photonics substrate comprising optical circuits configured to process optical signals; and
 - a base substrate connected to the silicon photonics substrate and having electrical contacts configured to connect to electrical contacts on the substrate of the co-packaged optical module.
5. The co-packaged optical module of claim **4** wherein each of the light engines comprises a lid member that encloses the substrates and the silicon photonics substrate, that is attached to the base substrate, and that includes a port configured to receive and secure an optical connector.
6. The co-packaged optical module of claim **5** wherein optical connector comprises a planar light circuit.
7. The co-packaged optical module of claim **4** wherein the silicon photonics substrate comprises one or more laser circuits providing a plurality of wavelength division multiplexing communication channels.
8. An optical switch comprising:
 - a plurality of co-packaged optical modules arranged on a common substrate;
 - an additional substrate arranged below the common substrate, the additional substrate comprising additional circuits arranged on a bottom surface of the additional substrate opposite to the common substrate;
 - an interposer arranged between the common substrate and the additional substrate, the interposer comprising electrical contacts providing electrical connections between the common substrate and the additional substrate;
 - a base plate attached to the bottom surface of the additional substrate, the base plate including windows aligned with the additional circuits; and
 - a heat sink arranged above the plurality of the co-packaged optical modules.
9. The optical switch of claim **8** wherein:
 - the base plate comprises a plurality of alignment pins that pass through corresponding holes in the additional substrate and the interposer; and
 - a plurality of fasteners pass through the heat sink and the additional substrate and lock into the base plate.

* * * * *