



US011673709B2

(12) **United States Patent**
Turner

(10) **Patent No.:** **US 11,673,709 B2**
(45) **Date of Patent:** **Jun. 13, 2023**

(54) **SHIPPING CONTAINERS WITH INTERCHANGEABLE FEET**

(71) Applicant: **MACRO PLASTICS, INC.**, Fairfield, CA (US)

(72) Inventor: **Todd T. Turner**, Corydon, IN (US)

(73) Assignee: **MACRO PLASTICS, INC.**, Fairfield, CA (US)

(*) Notice: Subject to any disclaimer, the term of this patent is extended or adjusted under 35 U.S.C. 154(b) by 150 days.

(21) Appl. No.: **17/318,402**

(22) Filed: **May 12, 2021**

(65) **Prior Publication Data**

US 2021/0354876 A1 Nov. 18, 2021

Related U.S. Application Data

(60) Provisional application No. 63/024,067, filed on May 13, 2020.

(51) **Int. Cl.**
B65D 19/40 (2006.01)
B65D 19/06 (2006.01)

(52) **U.S. Cl.**
CPC **B65D 19/40** (2013.01); **B65D 19/06** (2013.01); **B65D 2519/00273** (2013.01); **B65D 2519/00338** (2013.01); **B65D 2519/00567** (2013.01); **B65D 2519/00676** (2013.01)

(58) **Field of Classification Search**
CPC **B65D 19/40**; **B65D 19/06**; **B65D 2519/00676**; **B65D 2519/00567**; **B65D 2519/00338**; **B65D 2519/00273**
USPC **206/599, 386, 600**
See application file for complete search history.

(56) **References Cited**

U.S. PATENT DOCUMENTS

4,887,731	A	12/1989	Pett et al.	
6,357,366	B1 *	3/2002	Frankenberg	B65D 19/0026 108/57.25
7,607,542	B1 *	10/2009	Hsieh	B65D 25/04 220/4.31
D672,960	S	12/2012	Turner	
8,434,618	B2 *	5/2013	Mitchell	B65D 19/06 206/386
8,950,612	B2	2/2015	Turner	
2009/0127158	A1 *	5/2009	Apps	B65D 19/06 206/600

(Continued)

FOREIGN PATENT DOCUMENTS

DE	19802307	C2	2/2000	
GB	2477328	A *	8/2011	B29C 45/2628

(Continued)

OTHER PUBLICATIONS

(IPL) Macro, Macro Plastics, Inc.; Hybrid 1012; product guide; pp. 1-6; accessed from website Jun. 29, 2021; <https://www.macroplastics.com/product/hybrid-1012/>.

(Continued)

Primary Examiner — Rafael A Ortiz
(74) *Attorney, Agent, or Firm* — Wyatt, Tarrant & Combs, LLP; Max E. Bridges; Matthew A. Williams

(57) **ABSTRACT**

A shipping container comprising a basket, a plurality of feet, and a plurality of removable corner columns. In some embodiments, the shipping container comprises a basket, a plurality of feet, and a plurality of foot pads. Further embodiments include foot pads with drill release locks.

16 Claims, 31 Drawing Sheets

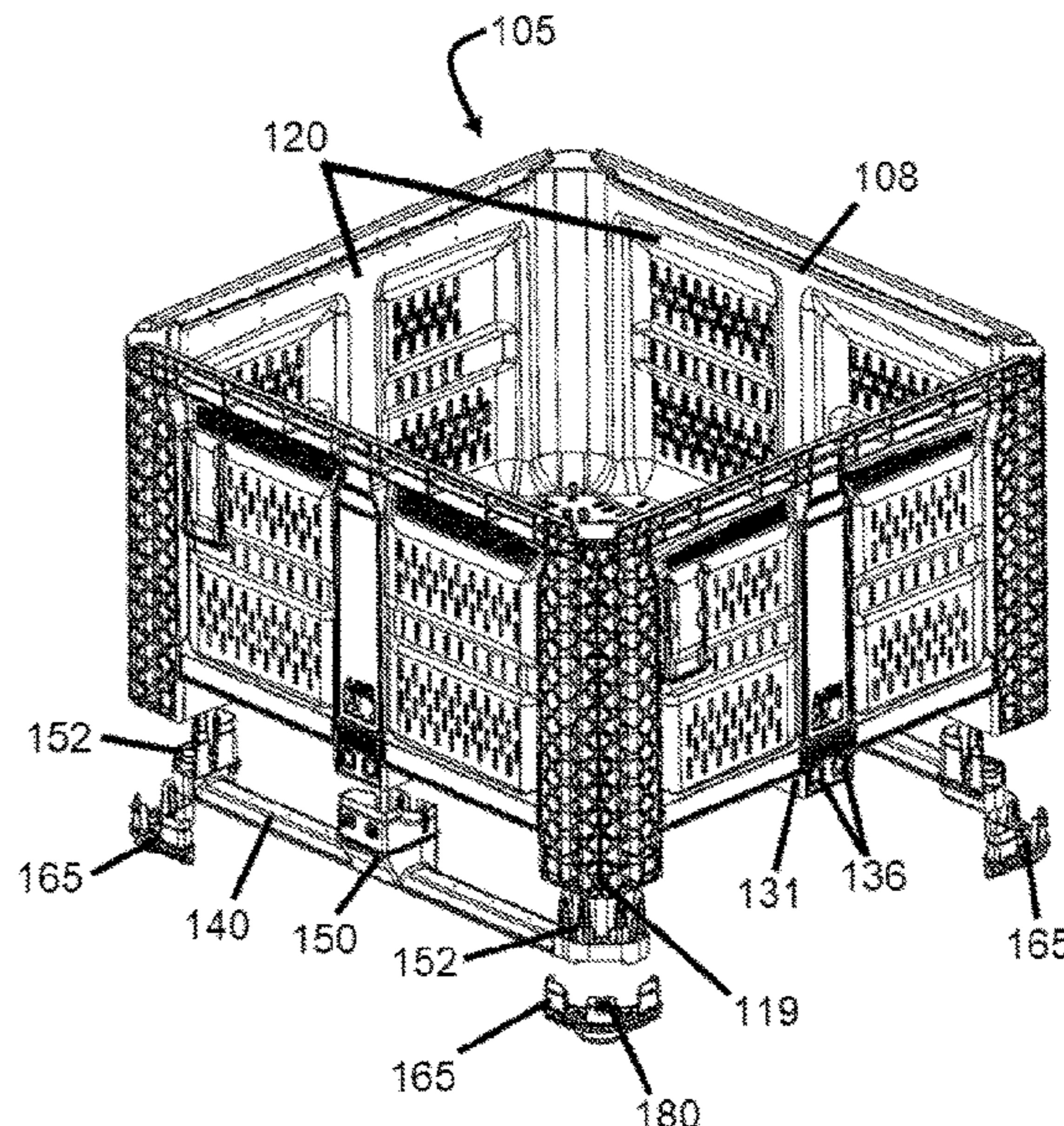
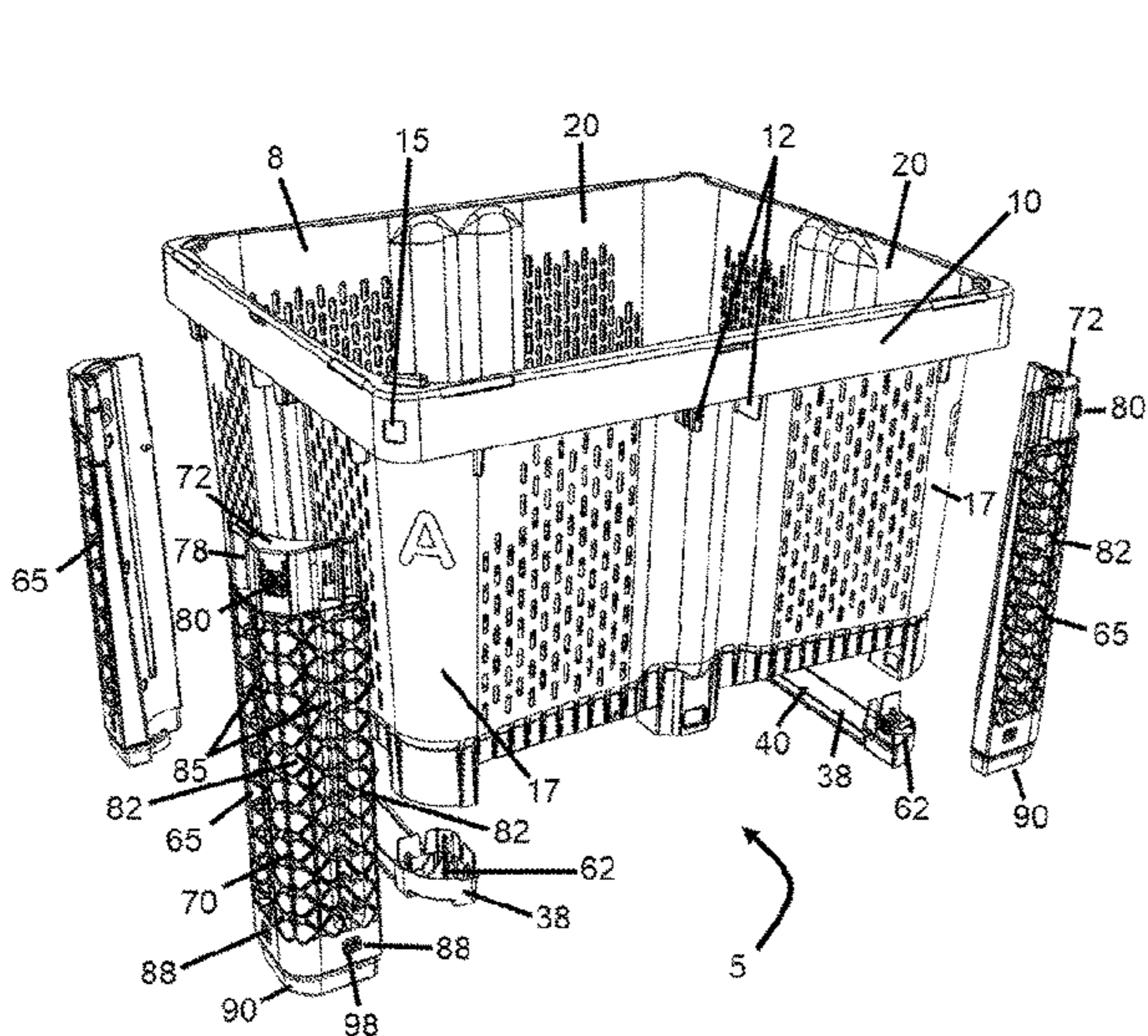

(56)

References Cited

U.S. PATENT DOCUMENTS

2016/0012926 A1* 1/2016 Lehnert G21F 5/012
250/506.1
2016/0288951 A1* 10/2016 Rader B65D 19/0016
2019/0203459 A1 7/2019 Fogg et al.

FOREIGN PATENT DOCUMENTS

WO WO-2012085941 A1* 6/2012 B65D 77/0466
WO WO-2012088297 A1* 6/2012 B65D 15/22

OTHER PUBLICATIONS

(IPL) Macro, Macro Plastics; Macroplastics Assembly and Disassembly of the Hybrid 1012; YouTube video; https://www.youtube.com/watch?v=VD67X-pbj3w&feature=emb_title.
The United States Patent and Trademark Office; The International Search Report and the Written Opinion of the International Searching Authority, or the Declaration of PCT/US21/31951; dated Oct. 15, 2021; pp. 1-13; The United States Patent and Trademark Office (as Searching Authority); US.

* cited by examiner

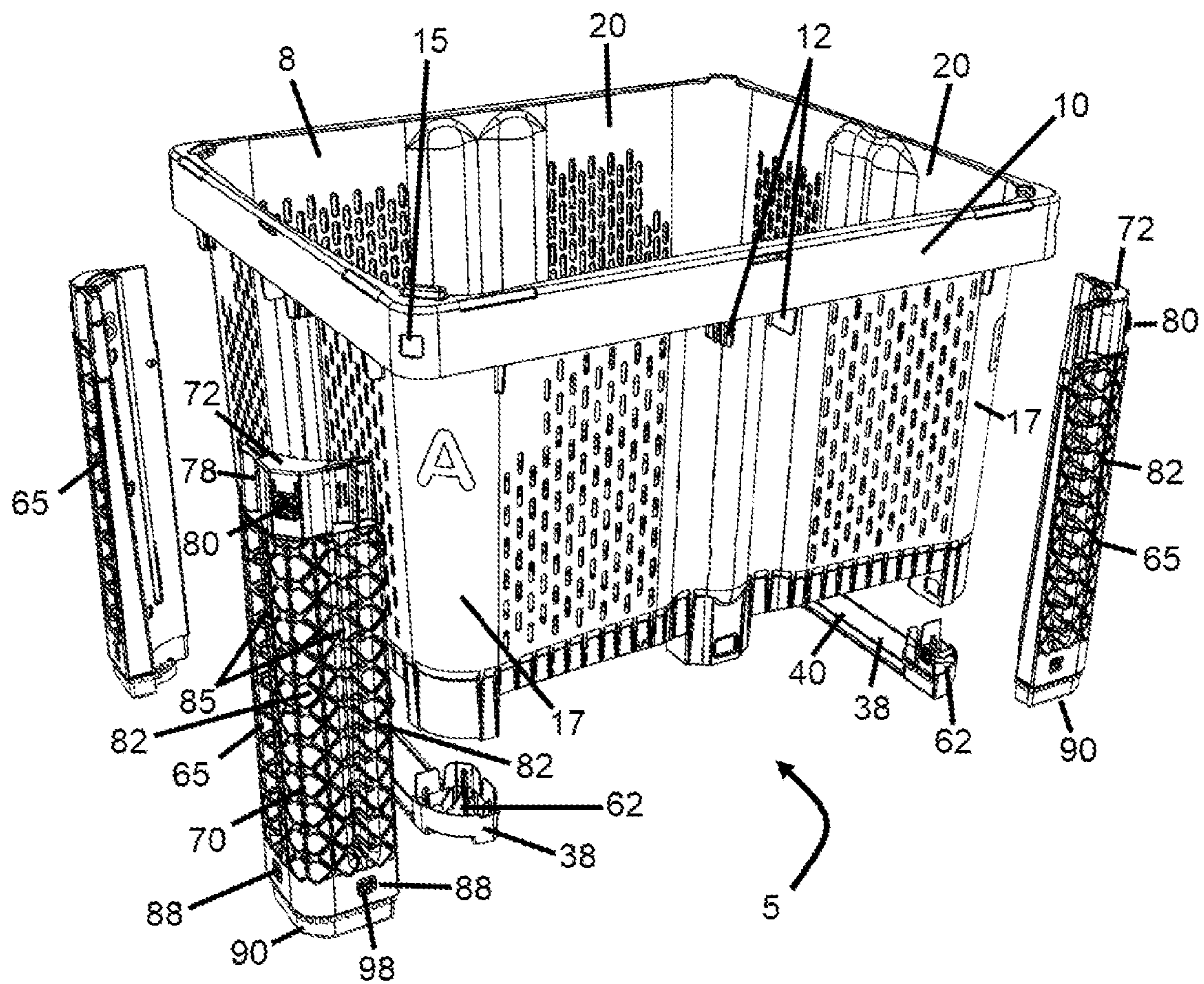

Figure 1

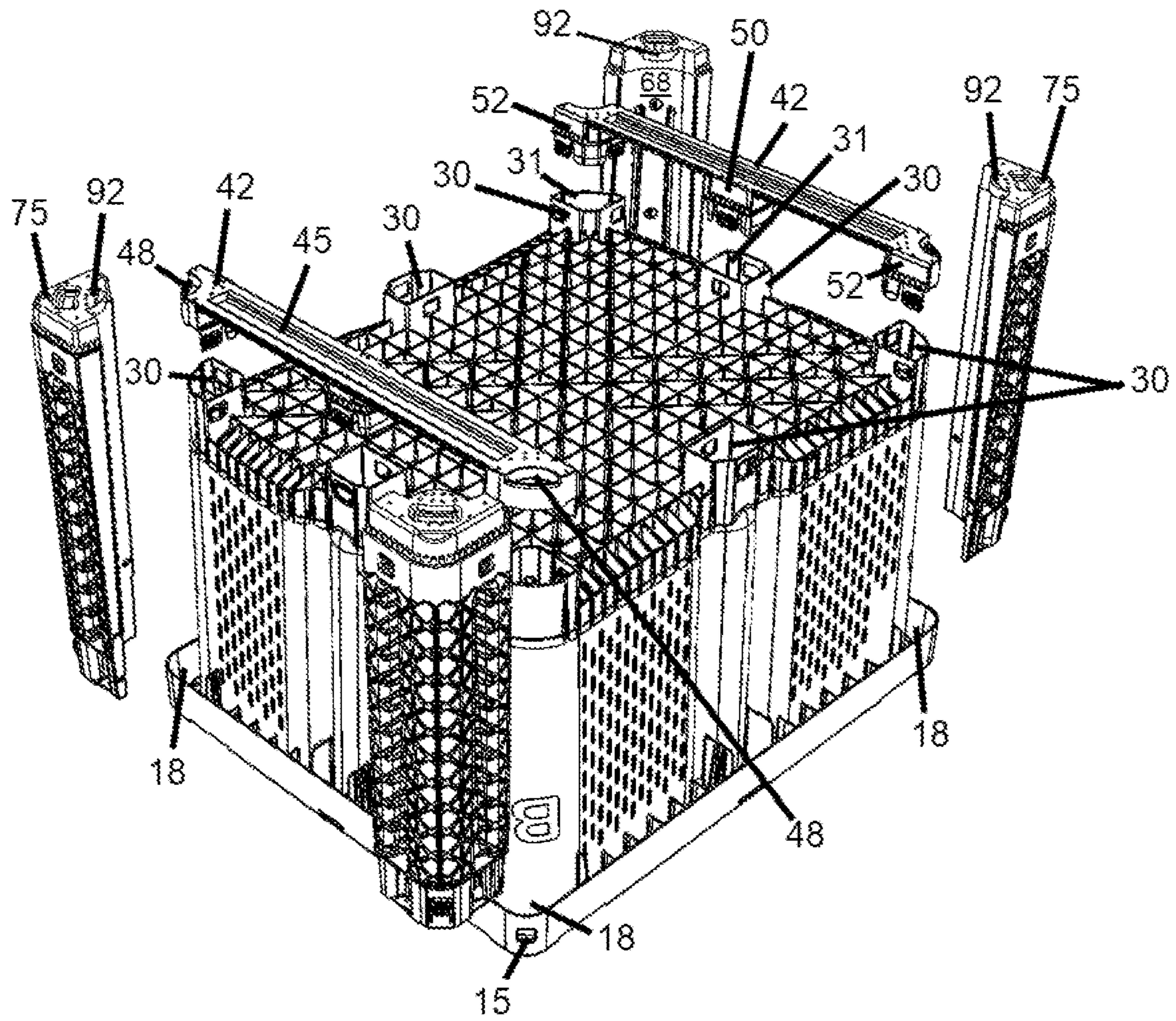

Figure 2

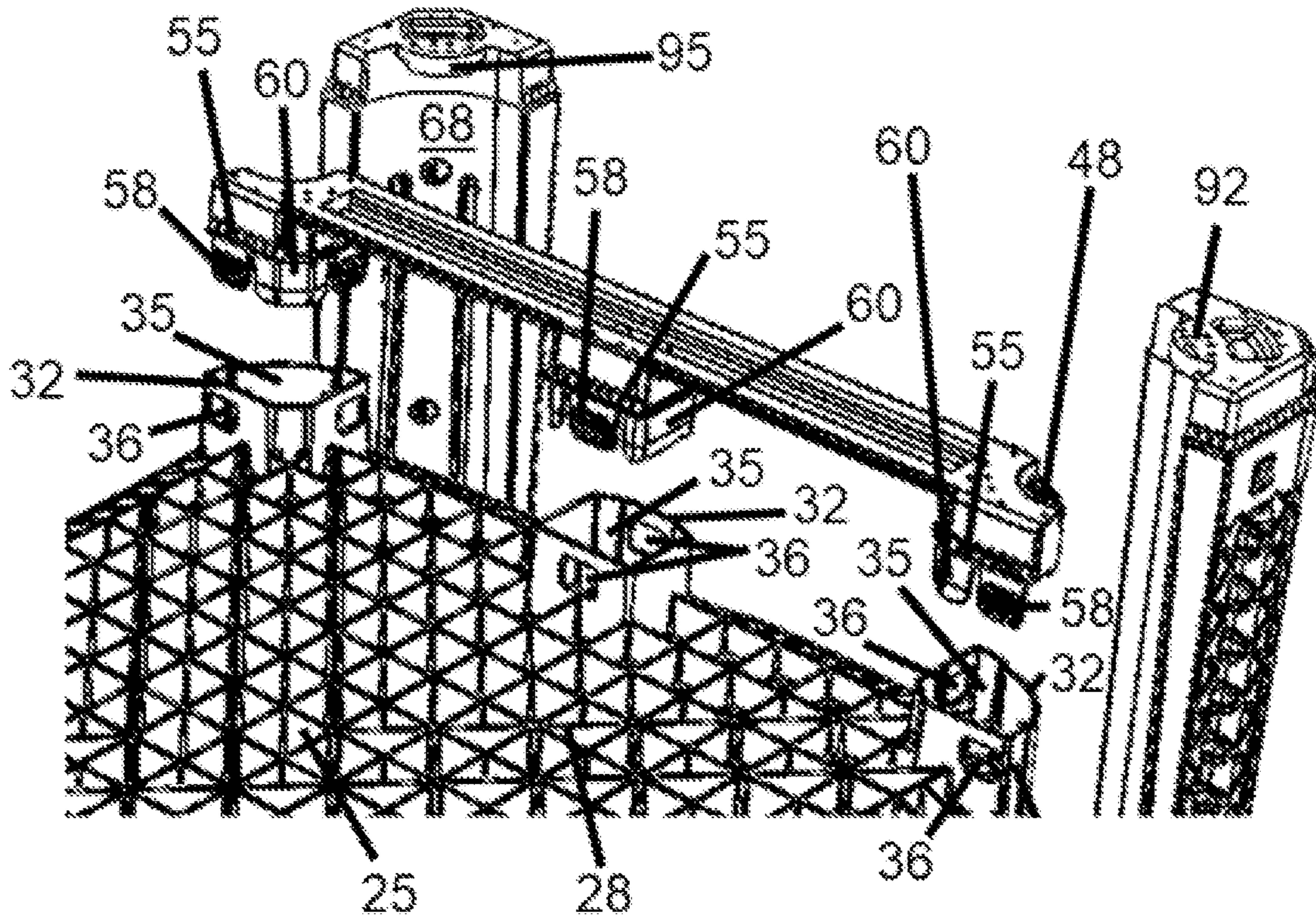

Figure 3

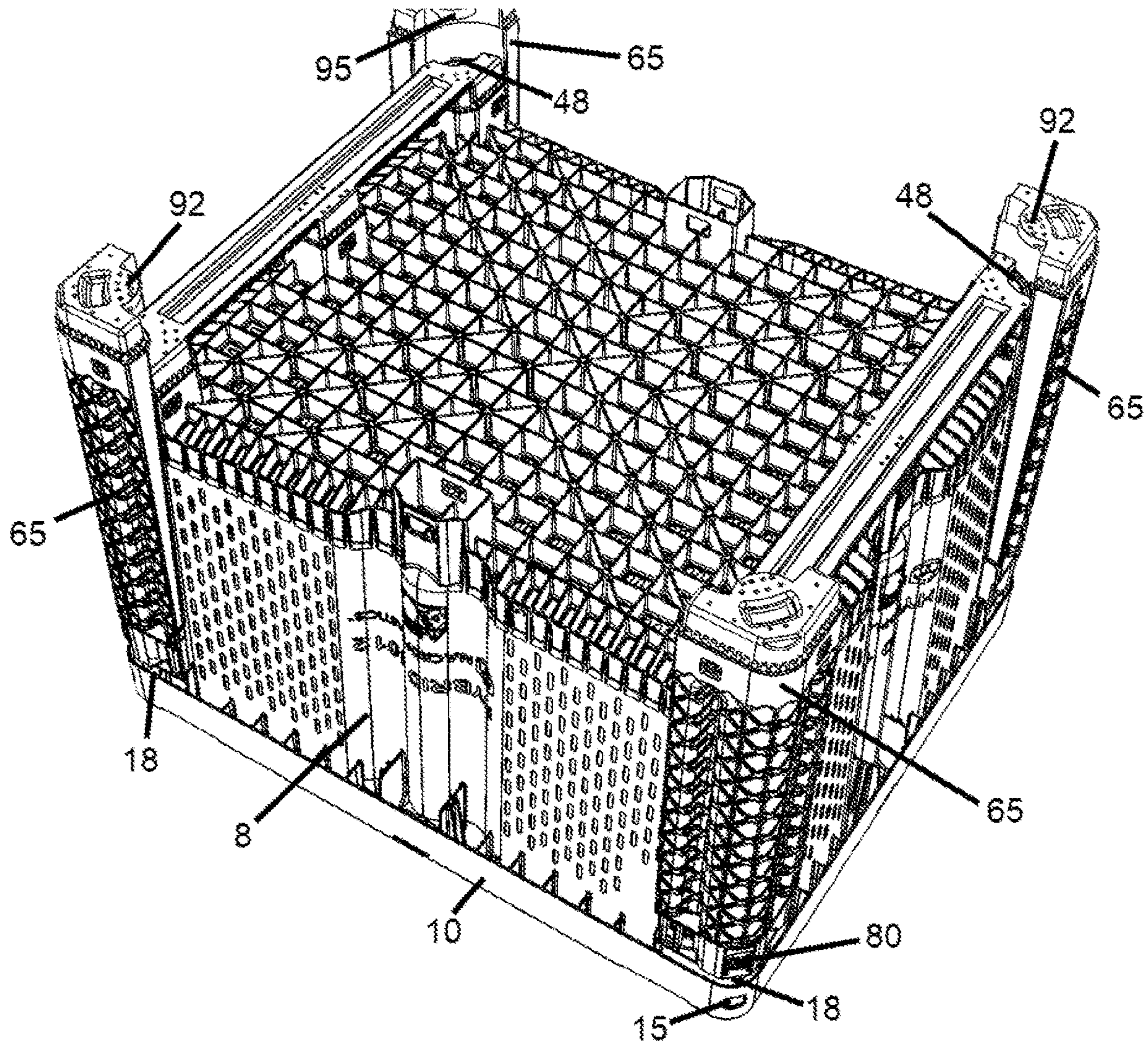

Figure 4

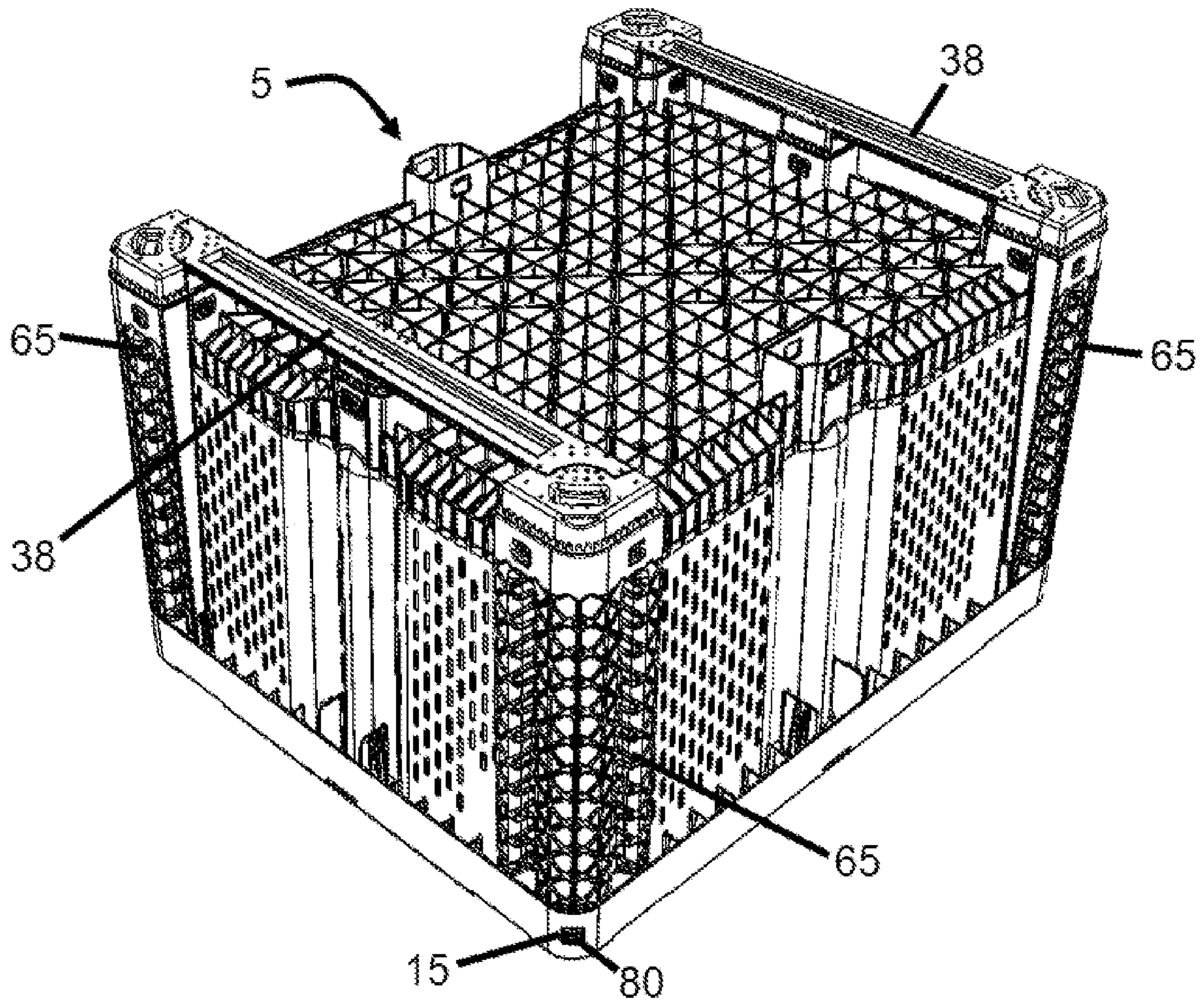

Figure 5

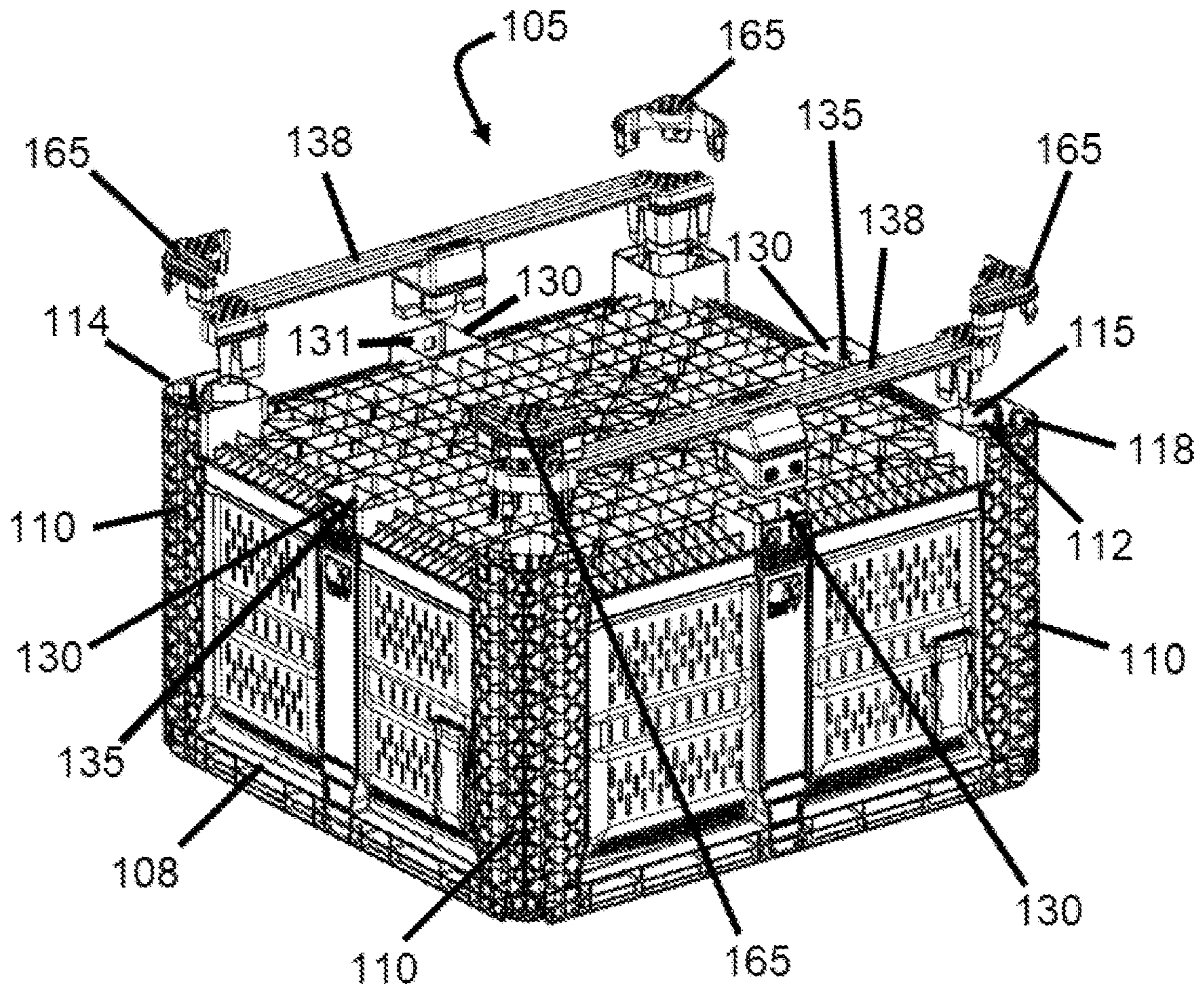

Figure 7

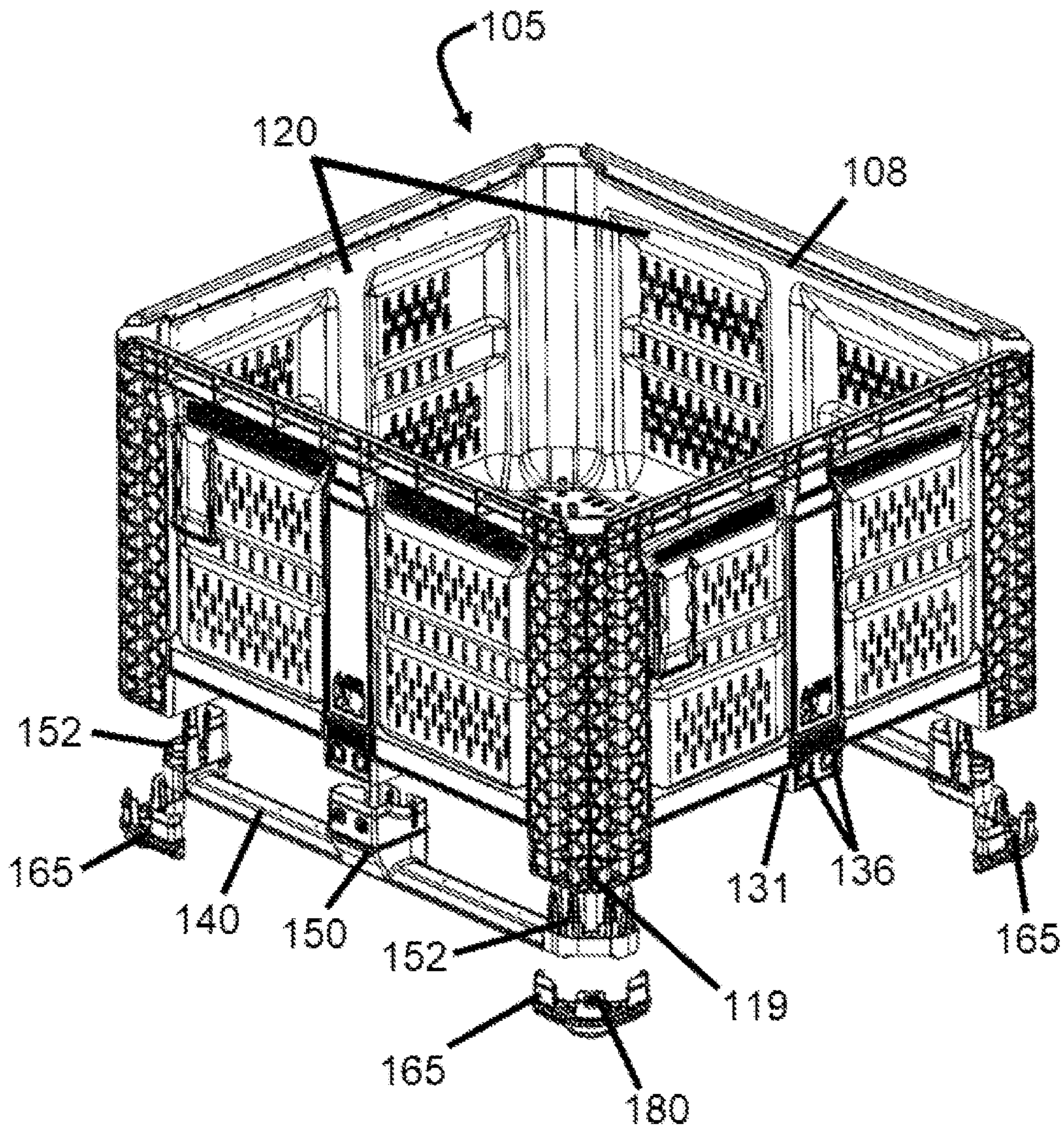

Figure 8

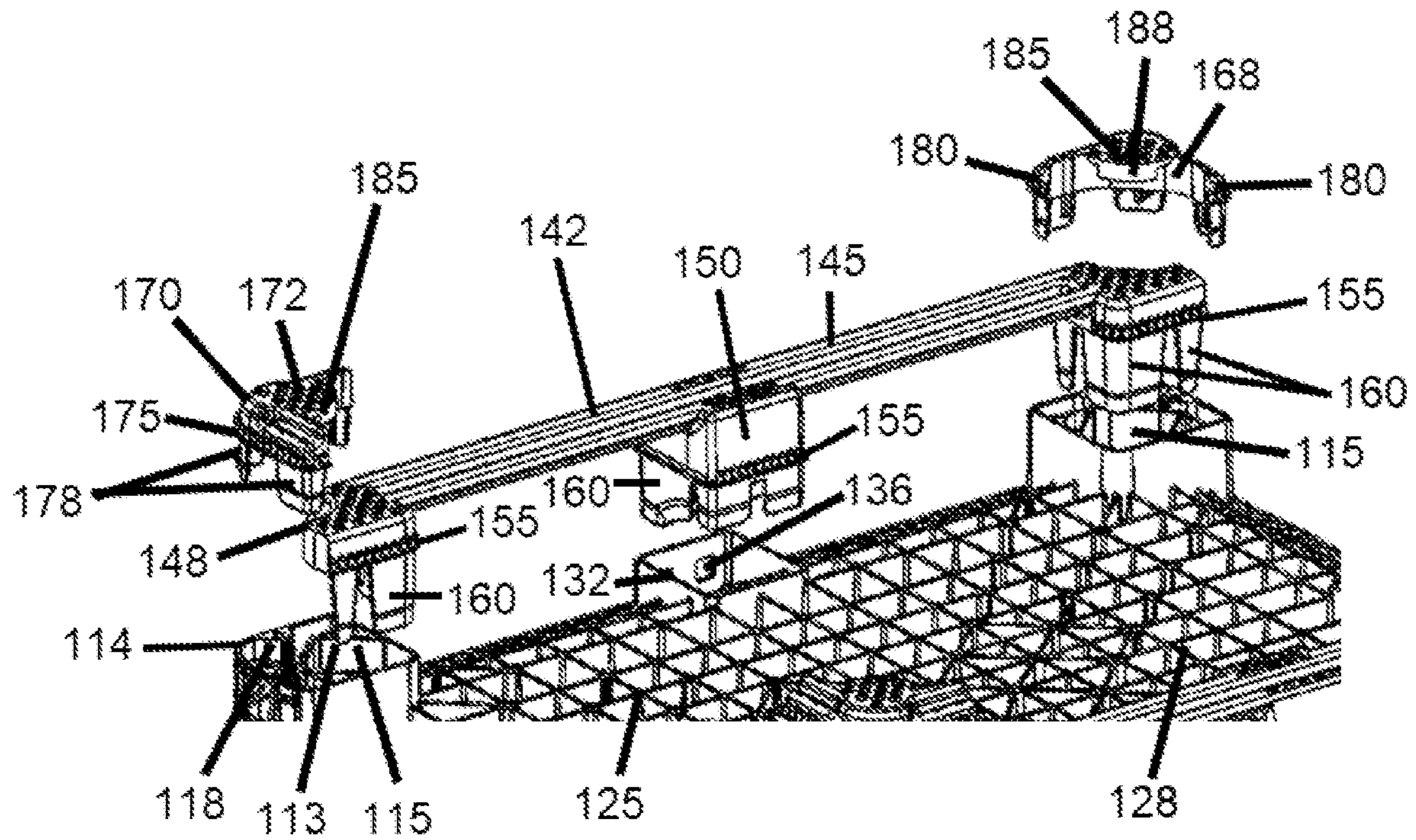

Figure 9

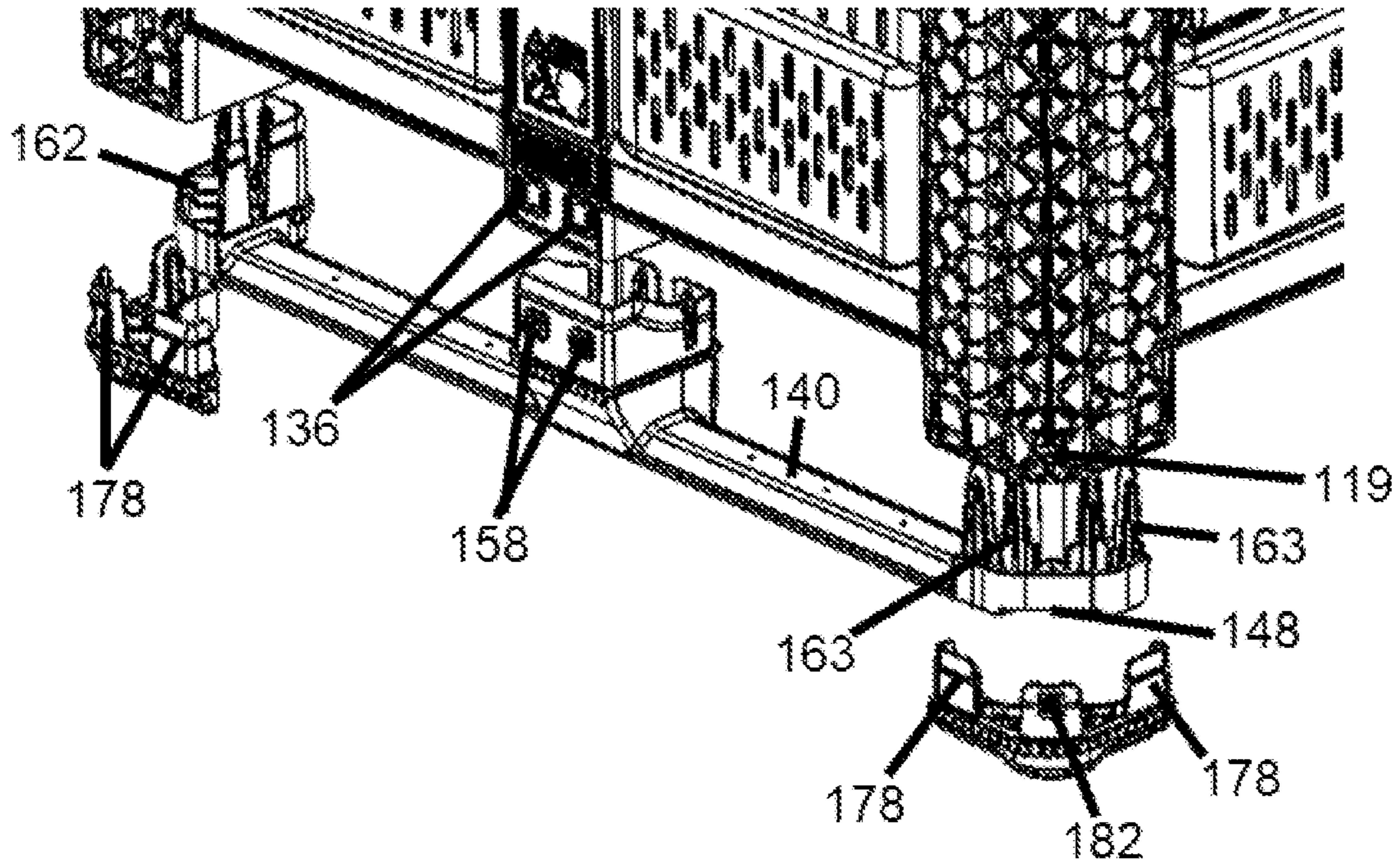

Figure 10

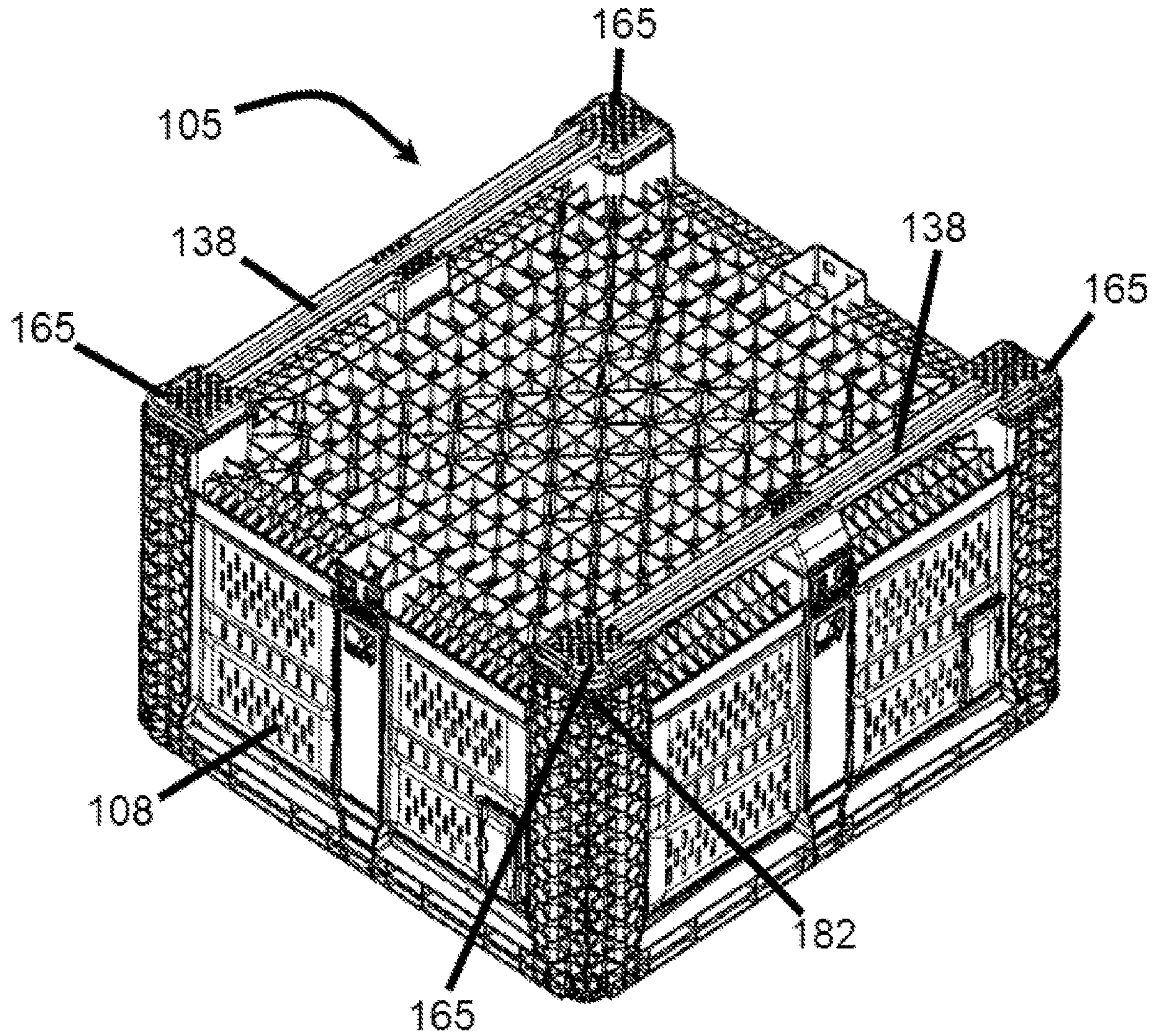

Figure 11

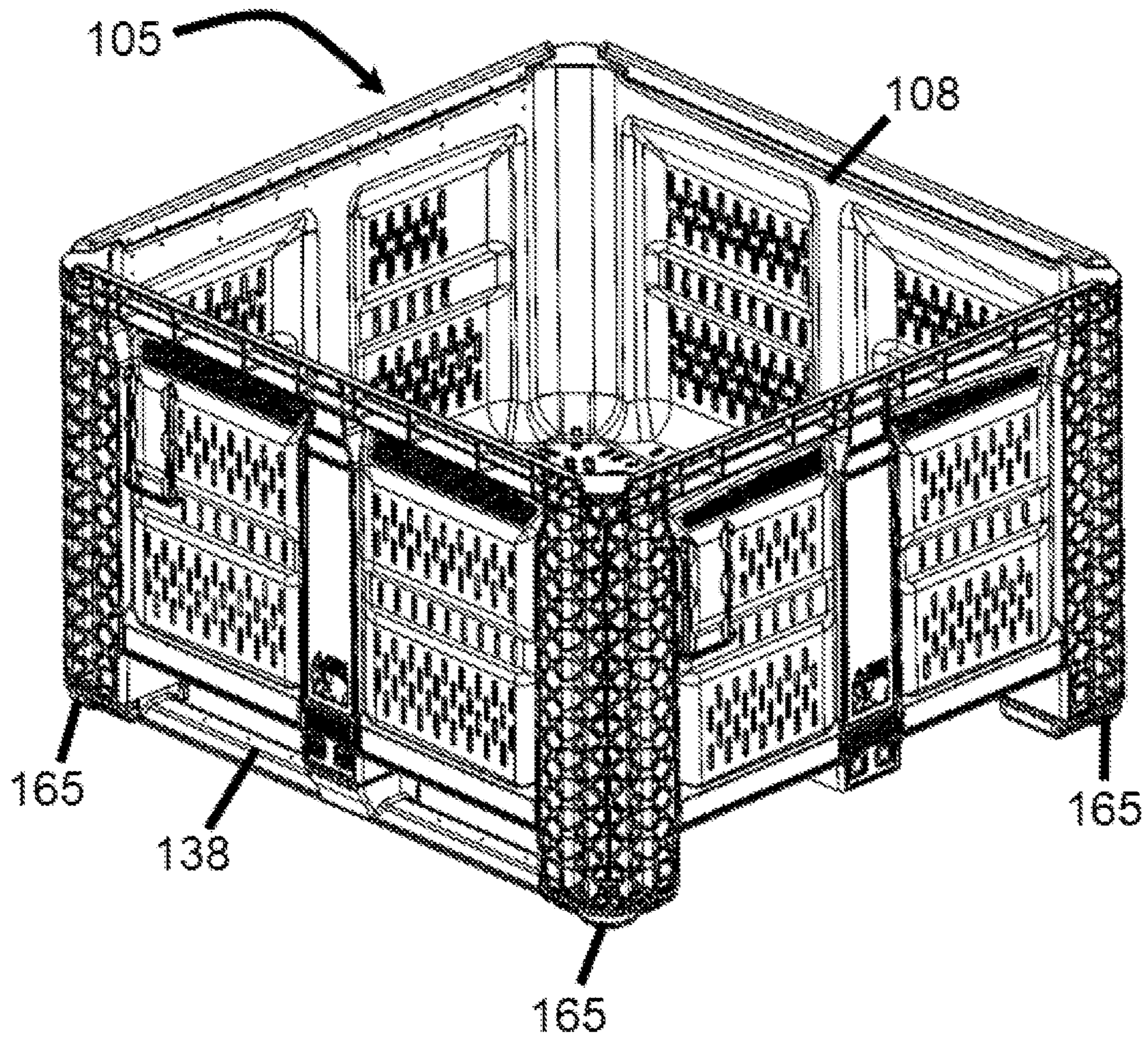

Figure 12

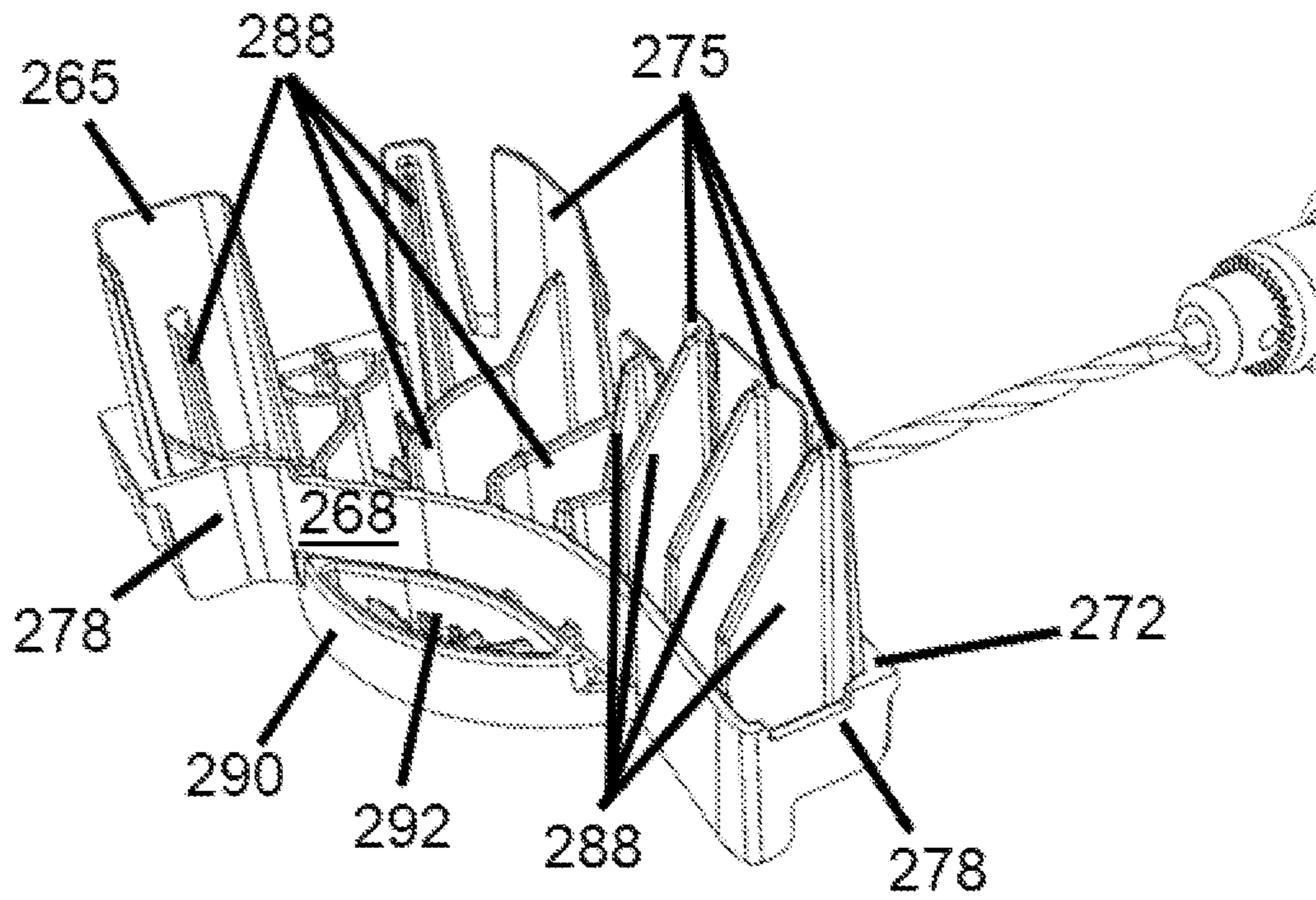

Figure 13

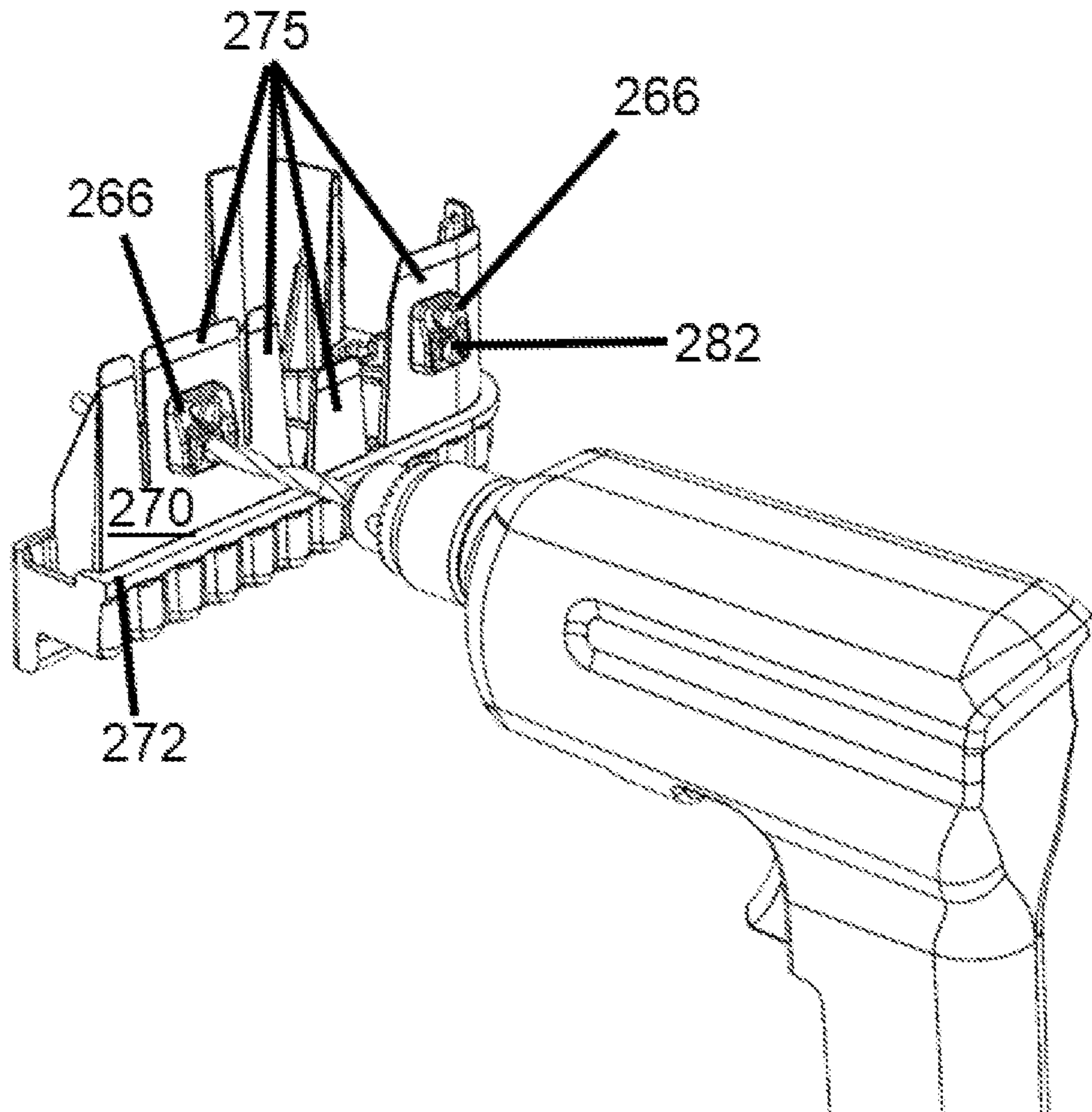

Figure 14

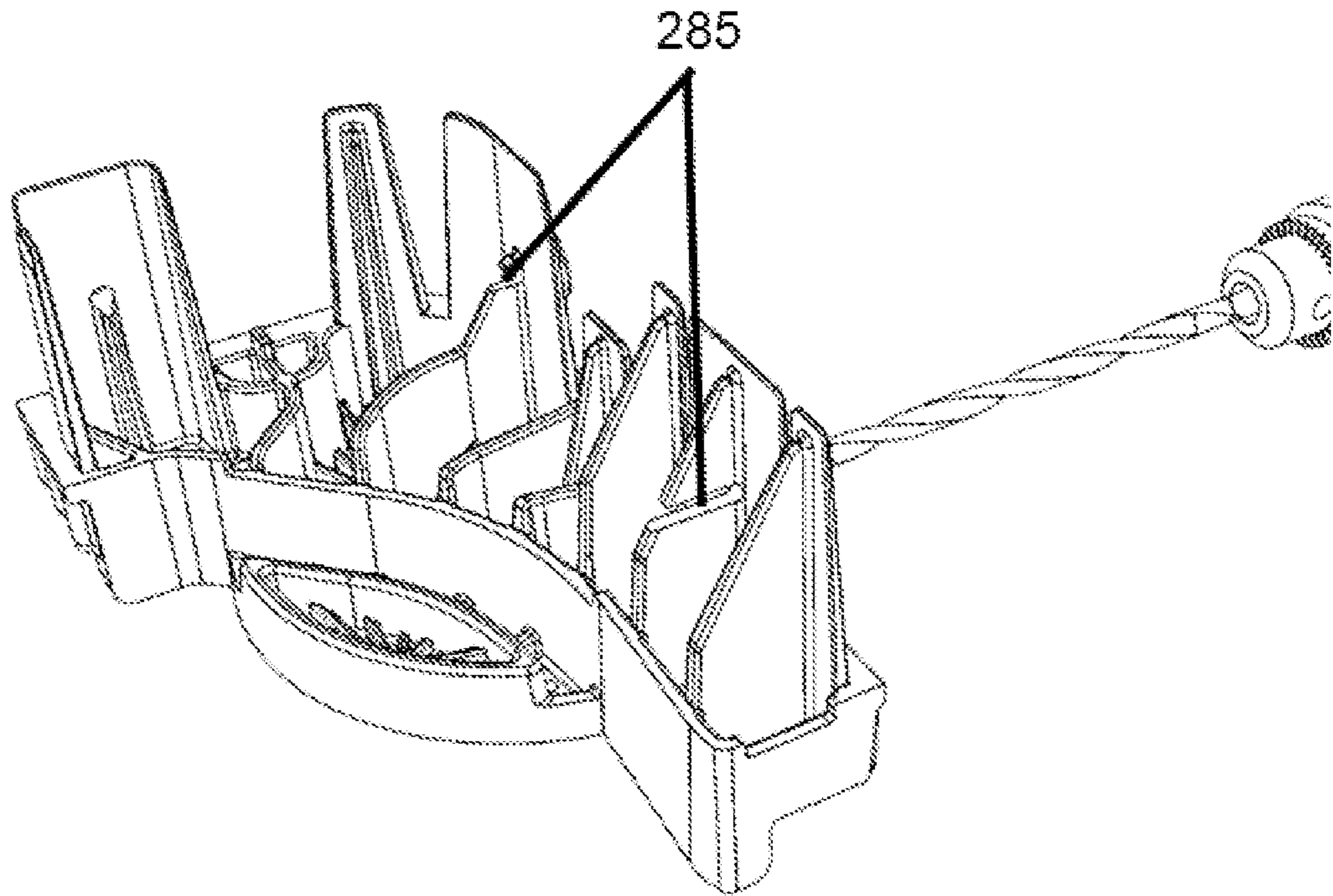

Figure 15

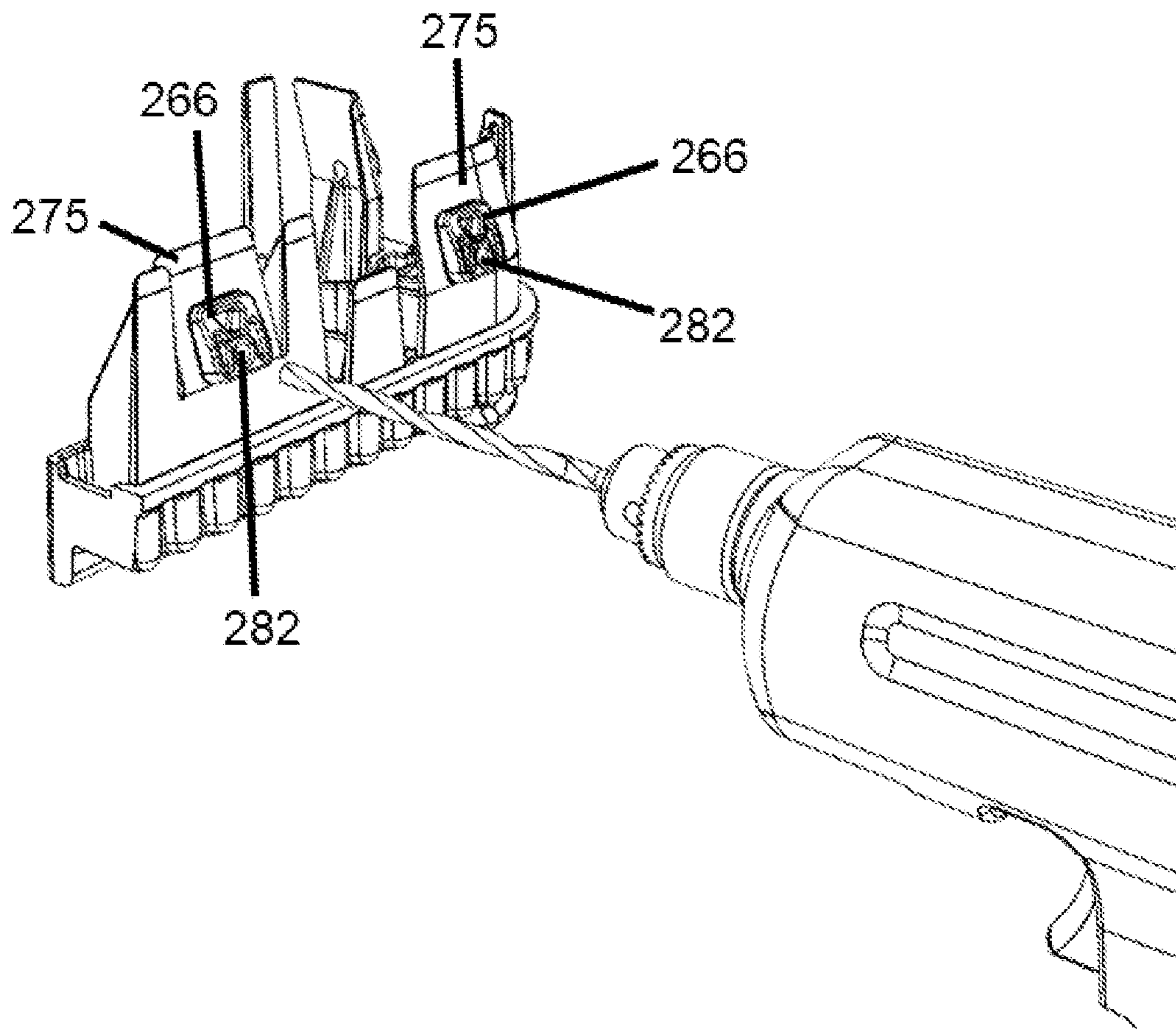

Figure 16

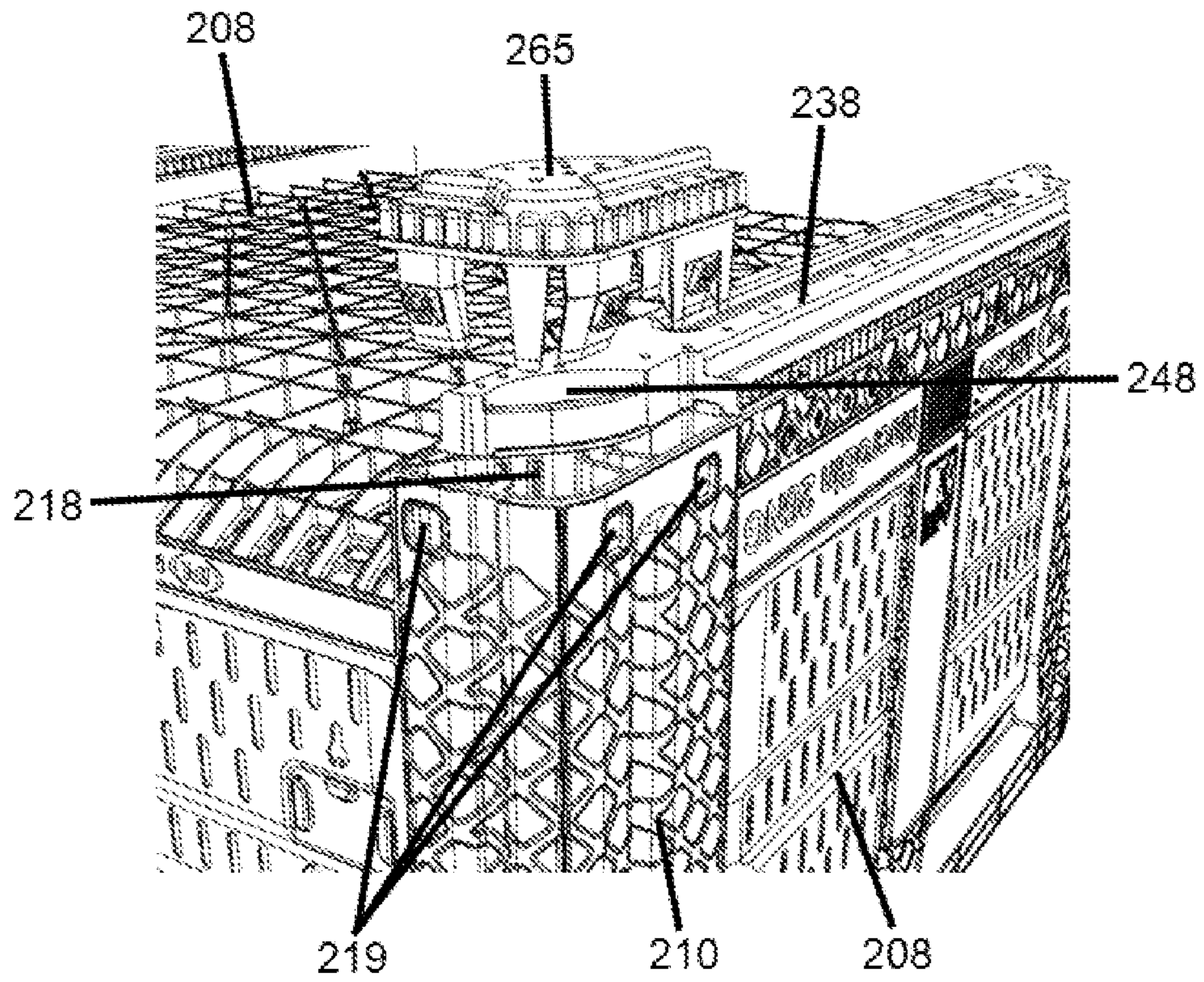

Figure 17

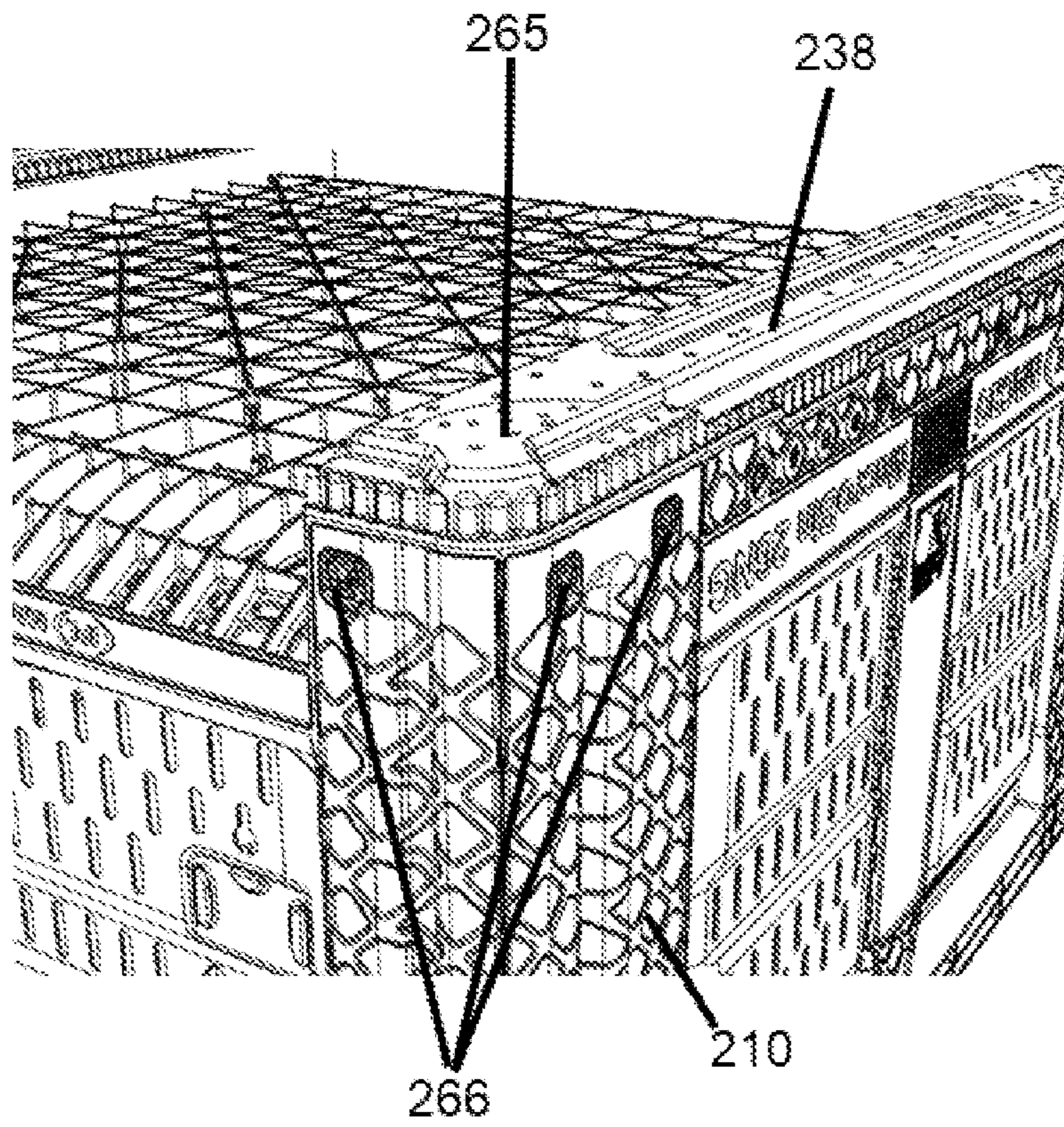

Figure 18

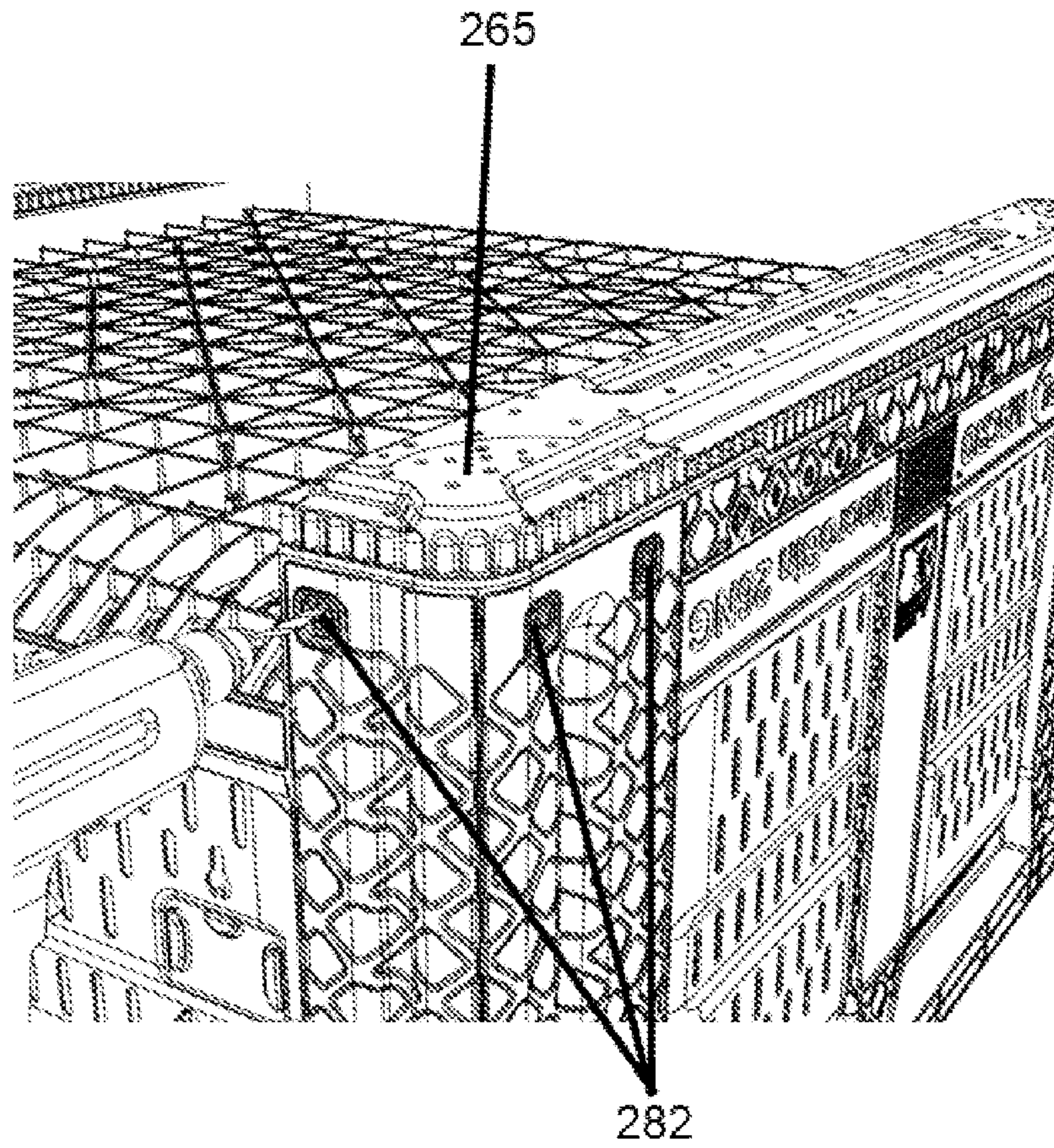

Figure 19

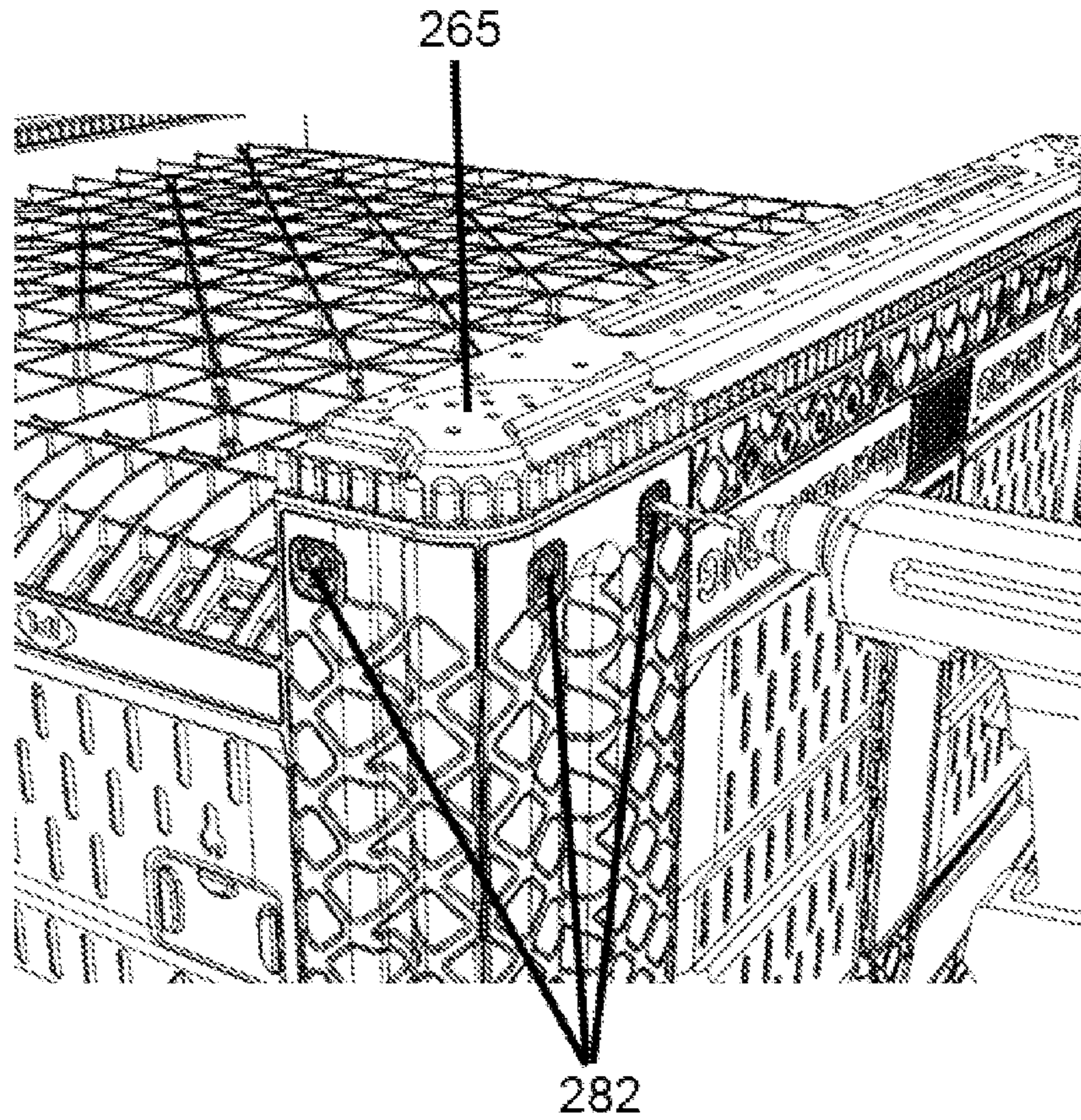

Figure 20

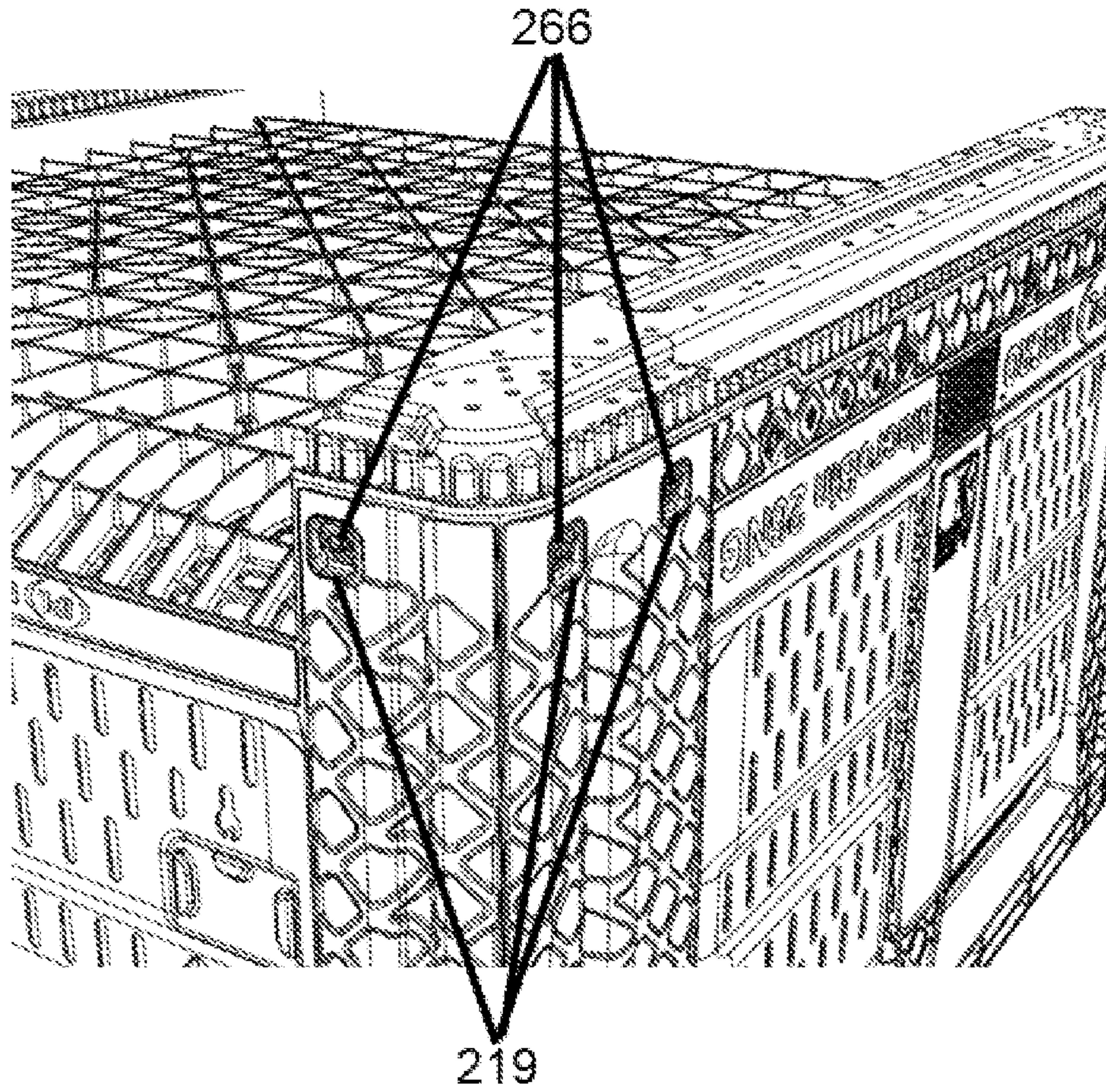

Figure 21

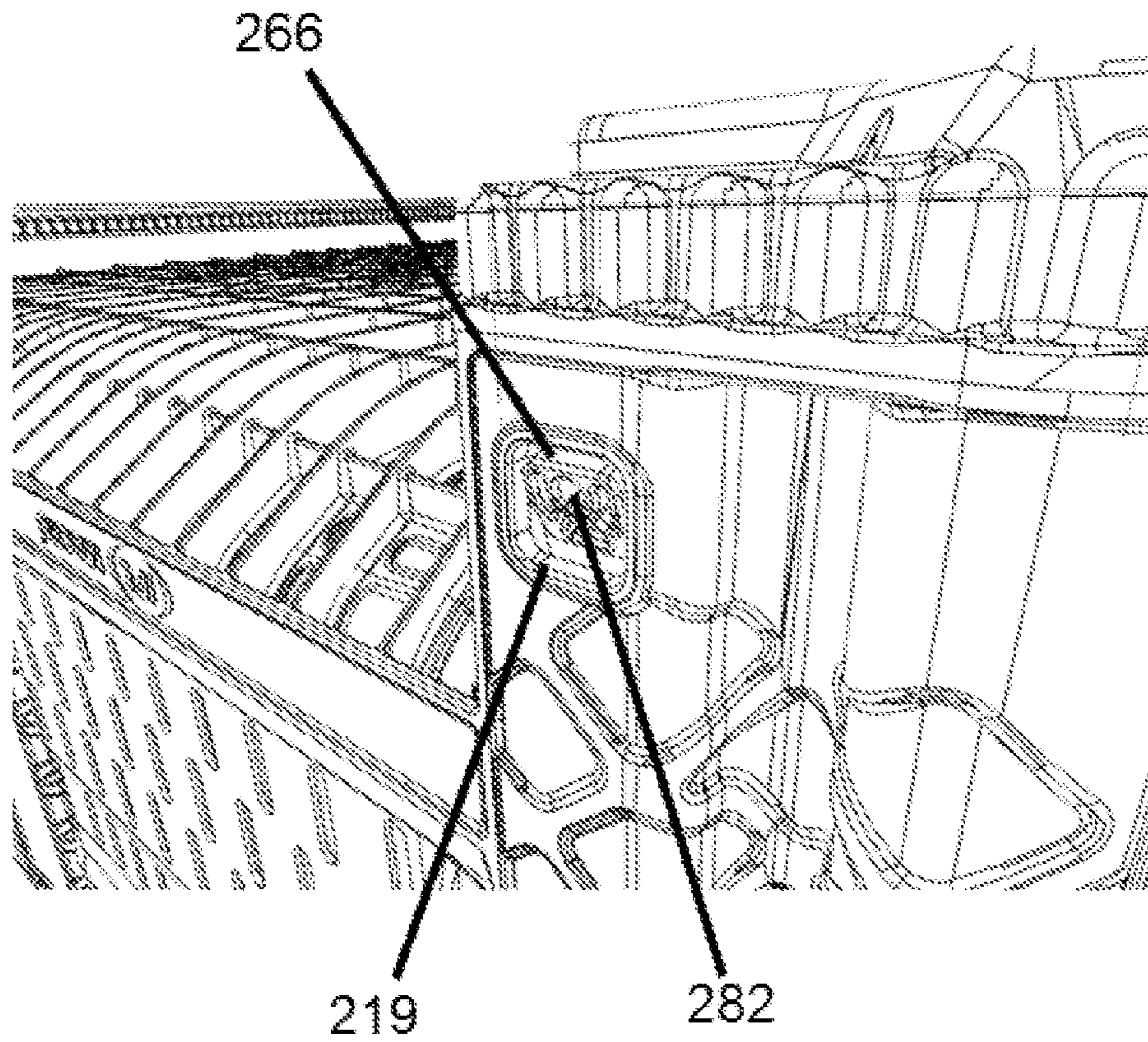

Figure 22

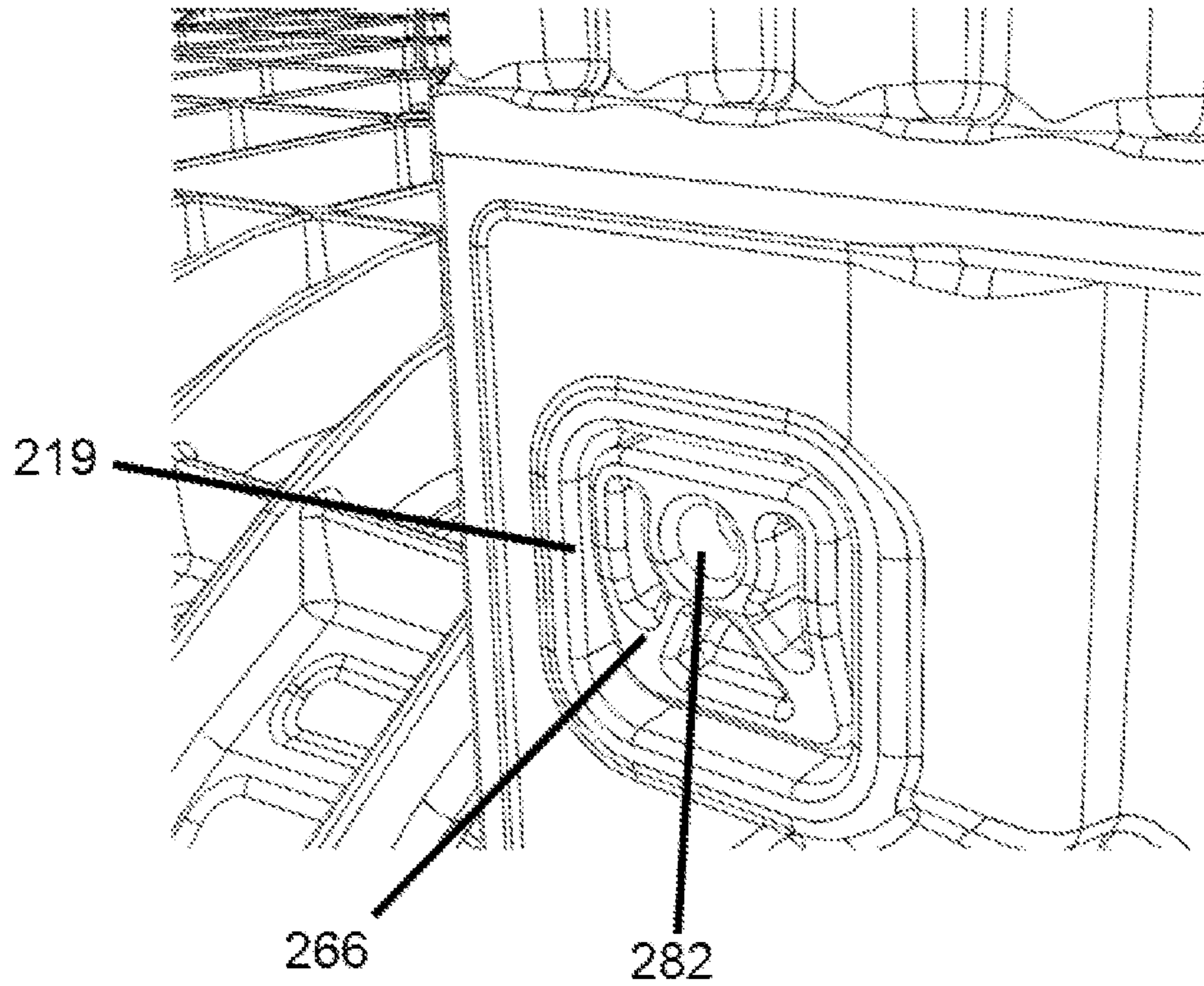

Figure 23

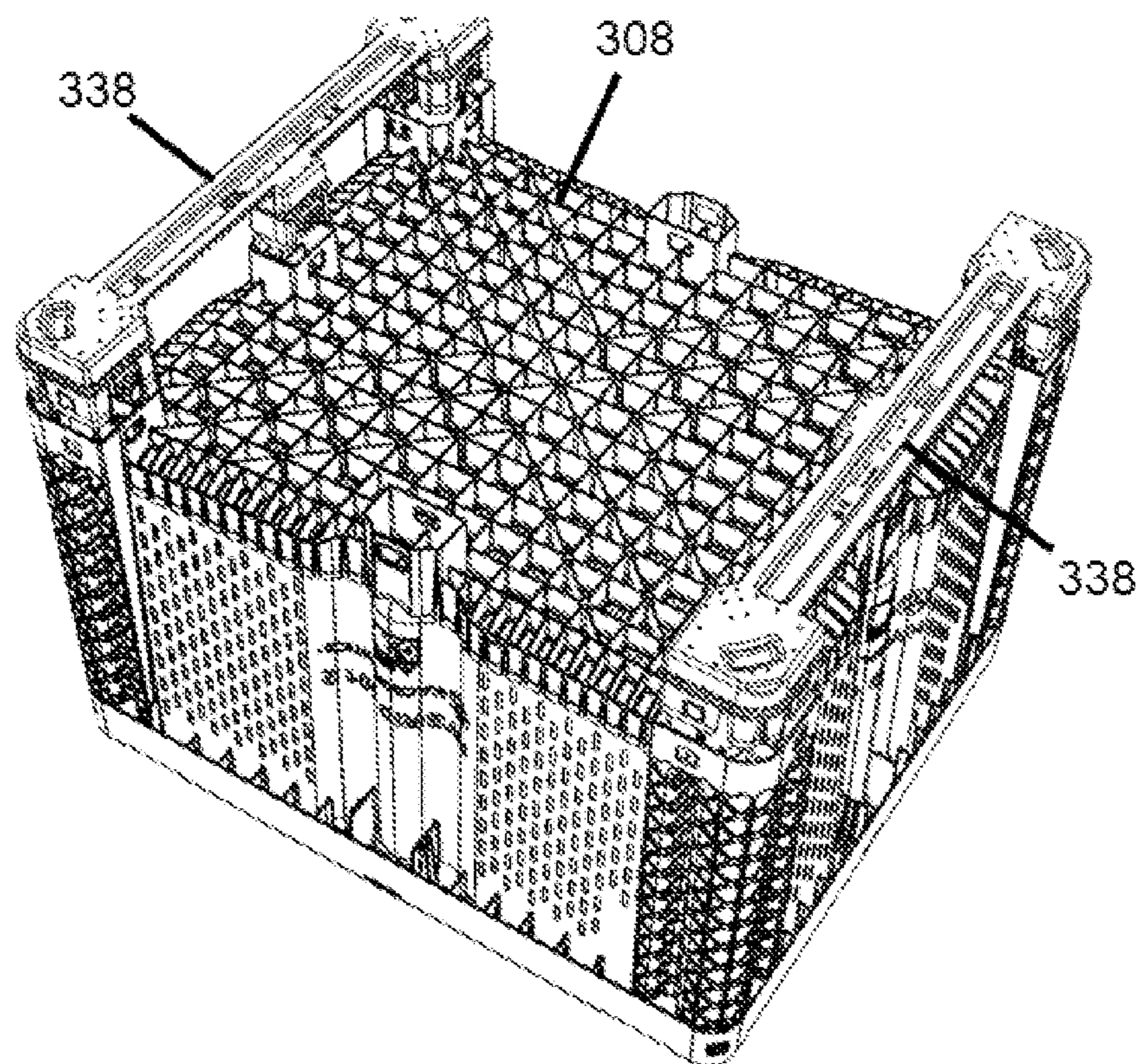

Figure 24

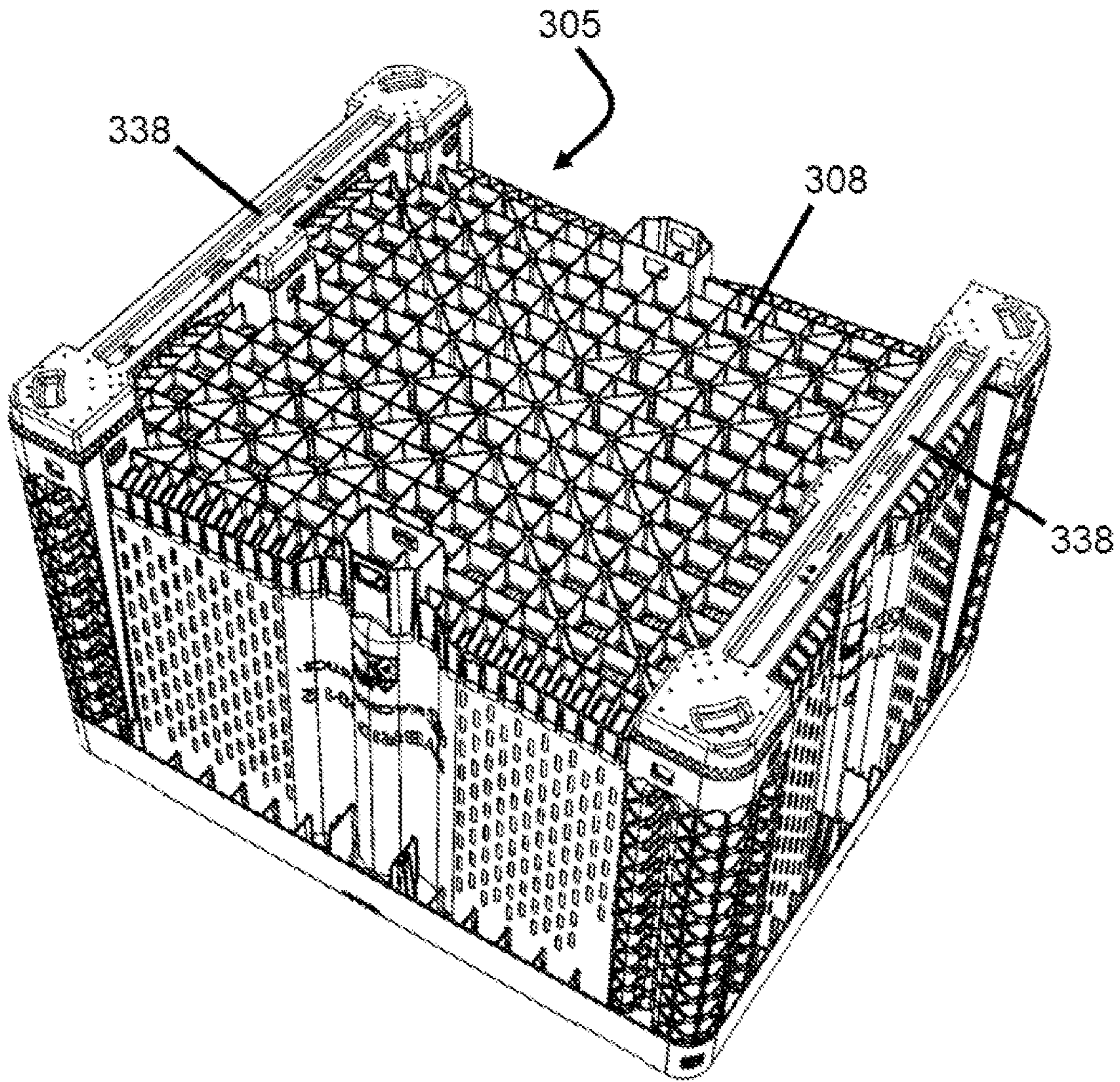

Figure 25

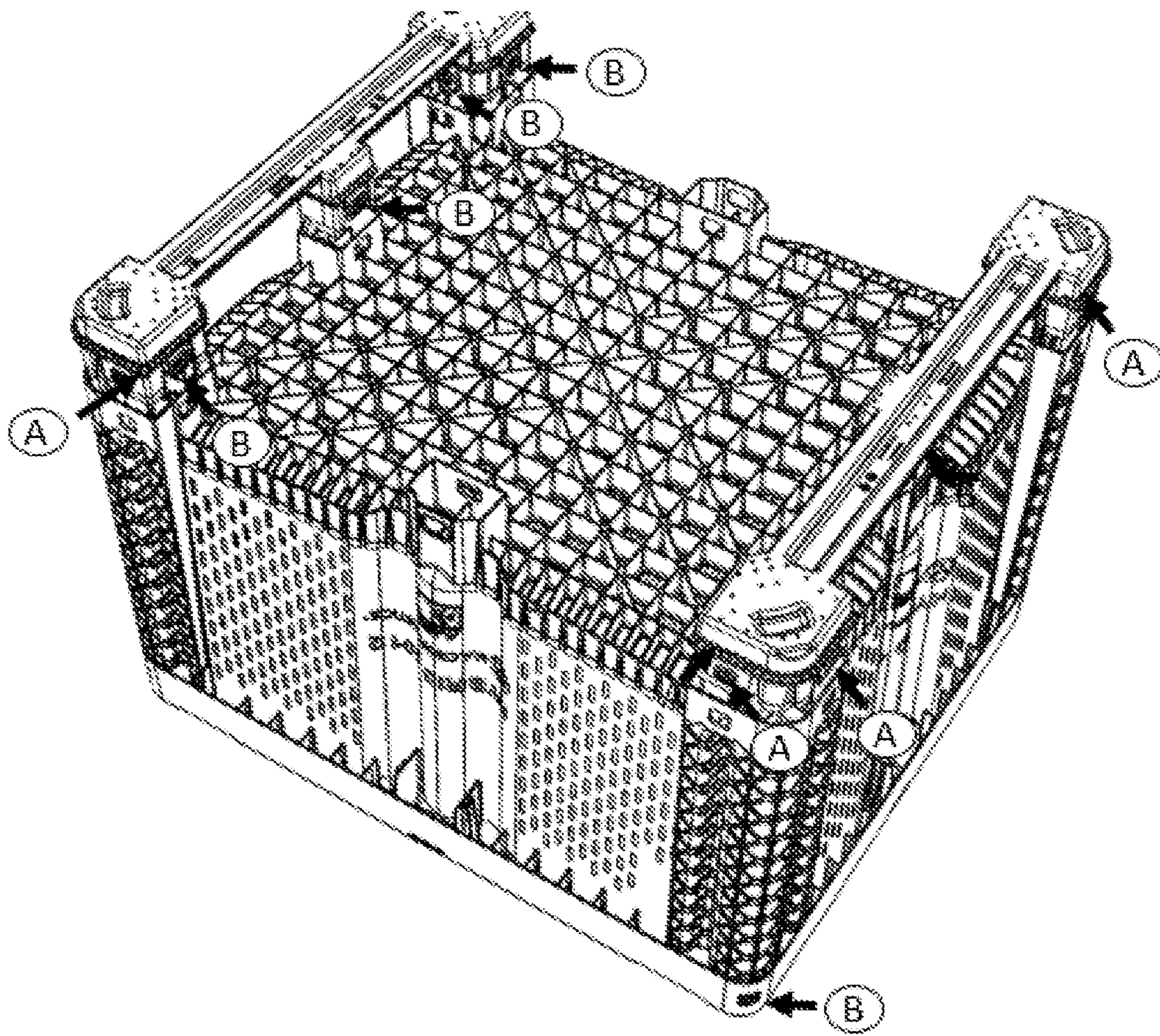

Figure 26

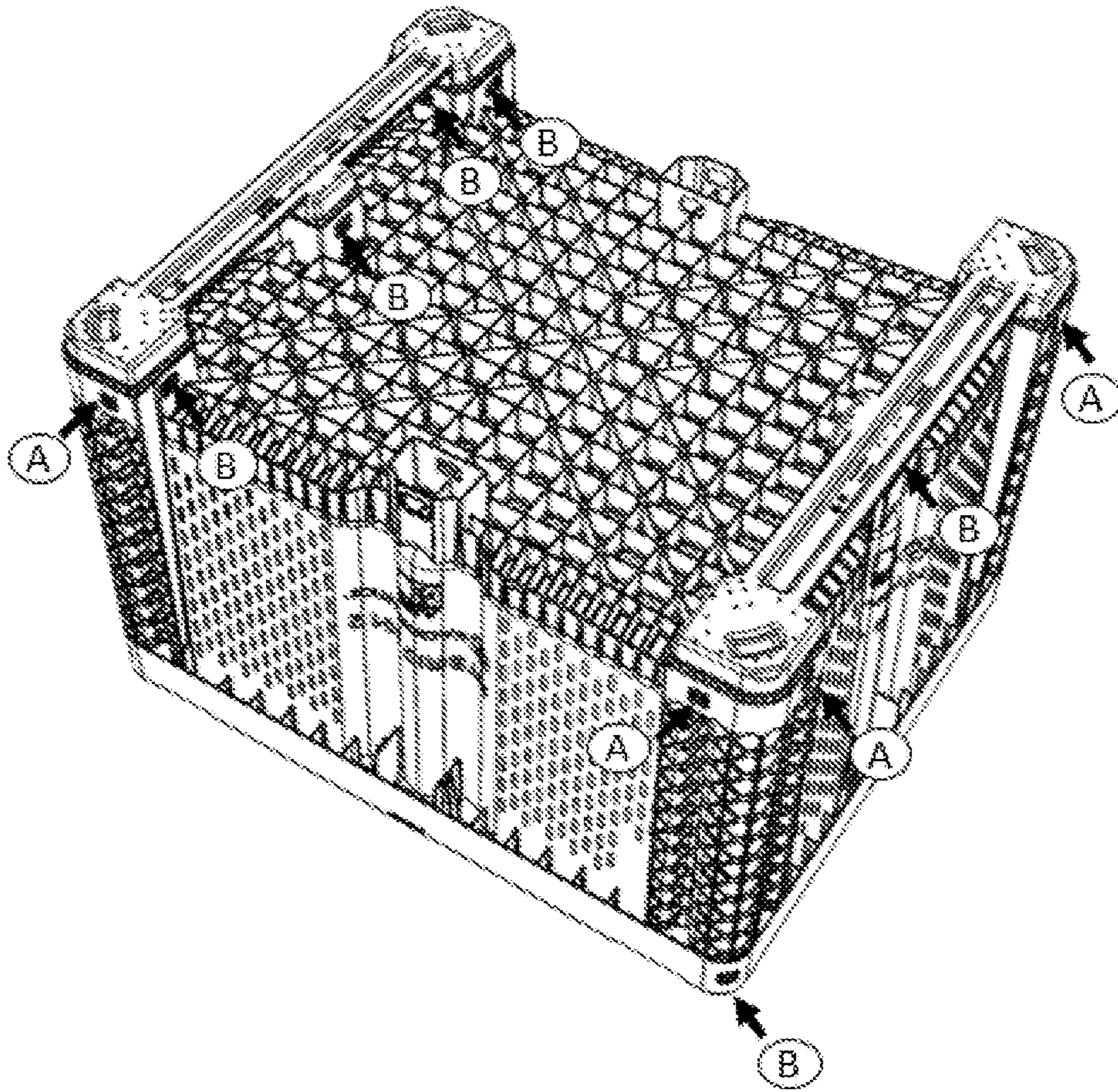

Figure 27

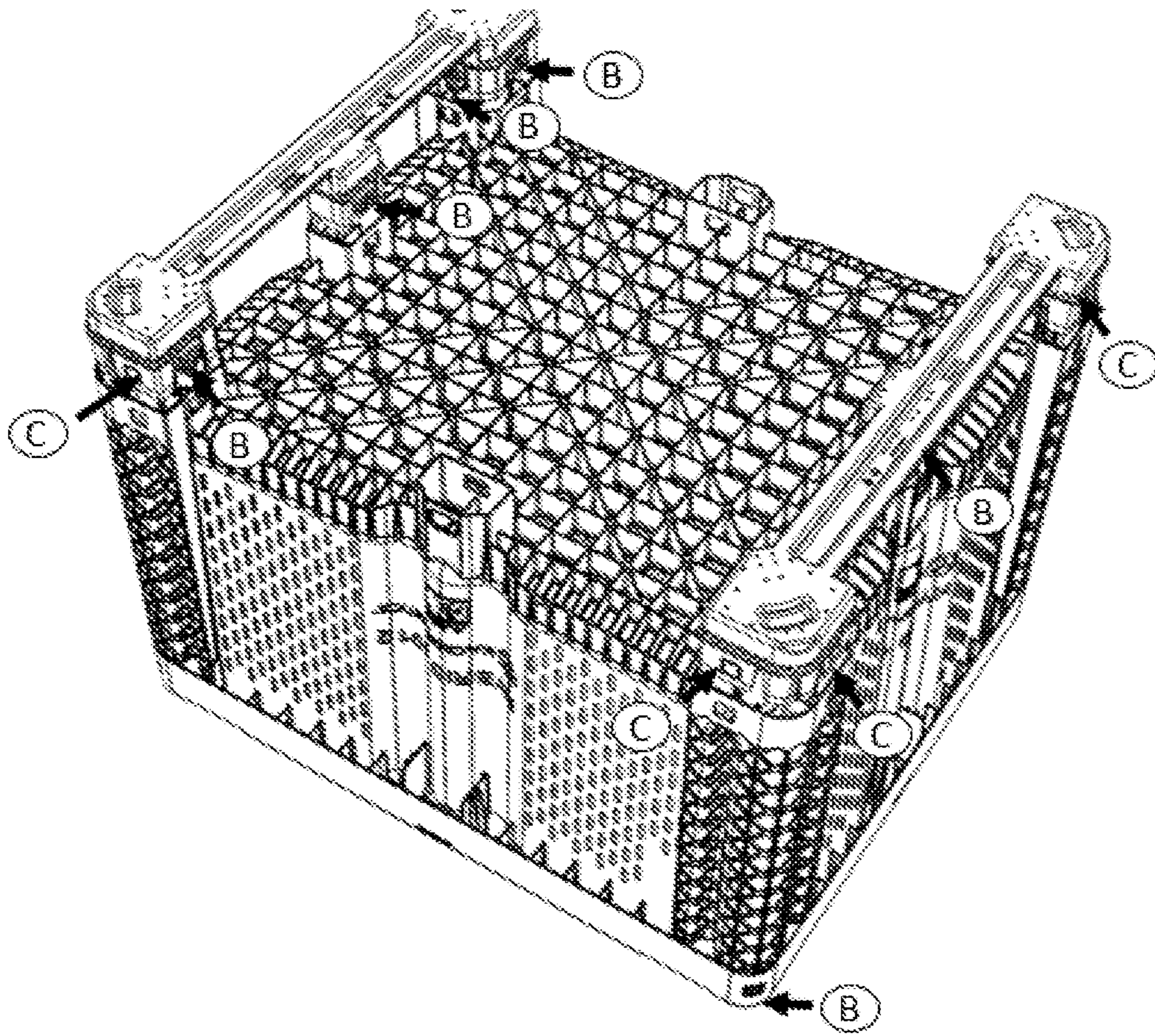

Figure 28

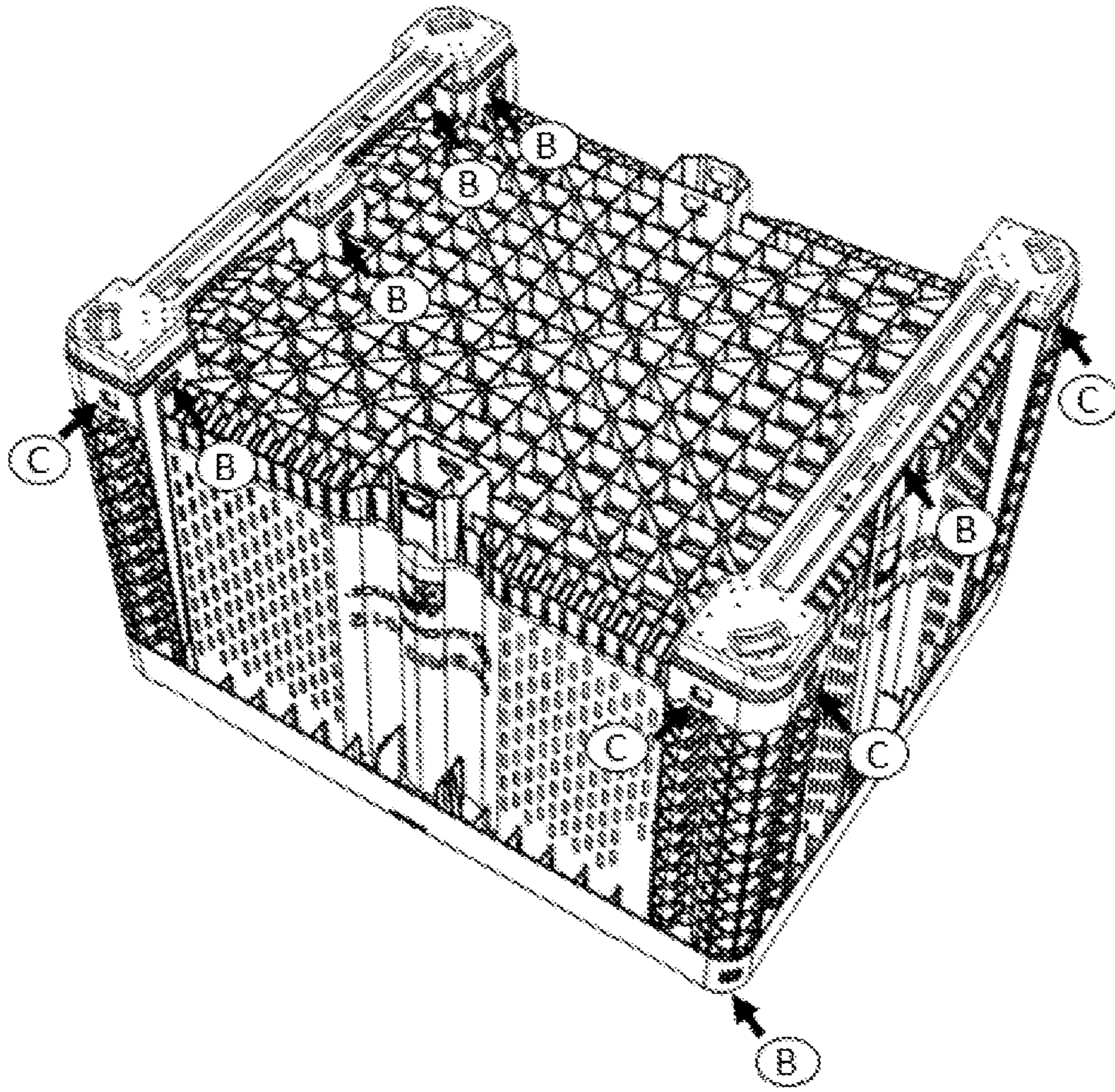

Figure 29

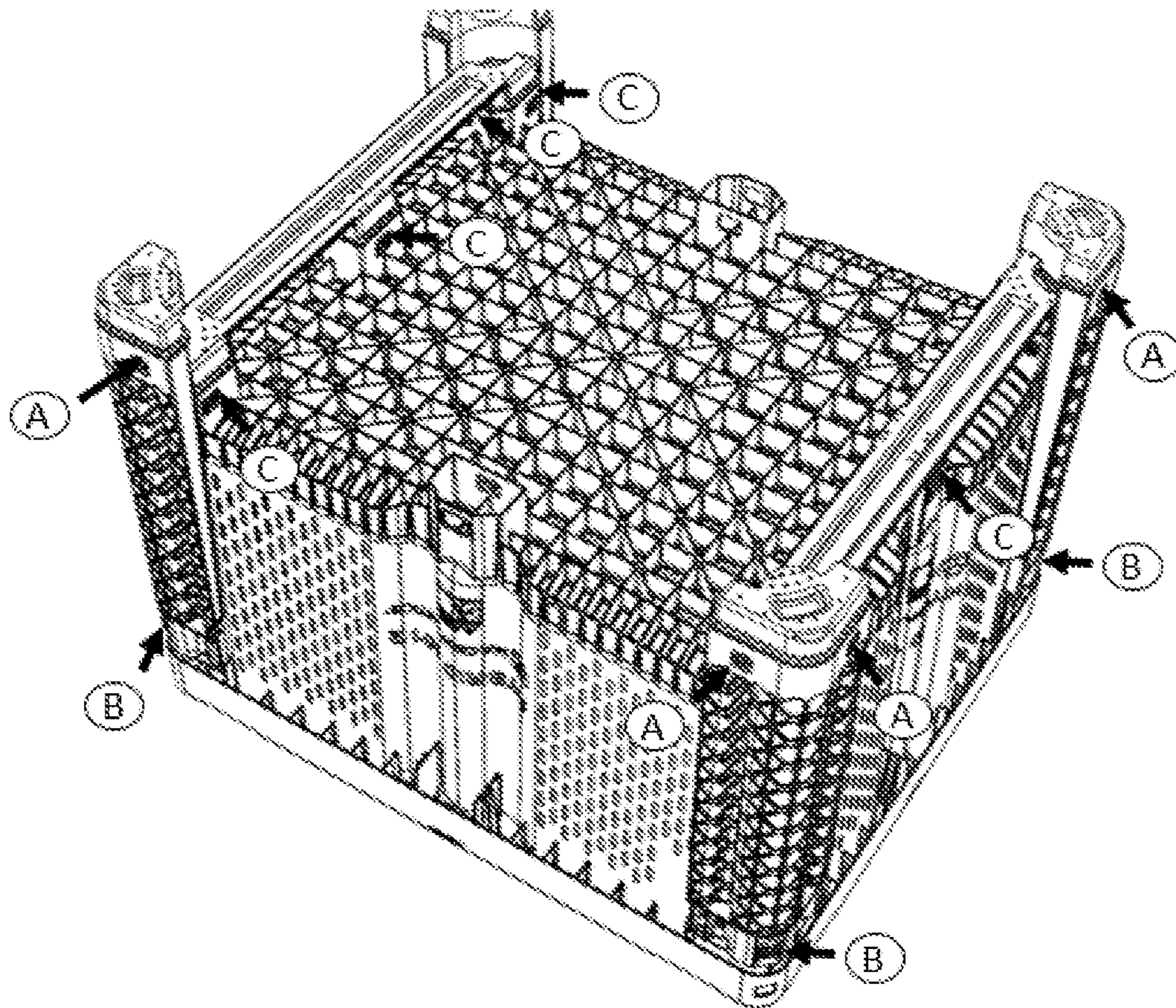

Figure 30

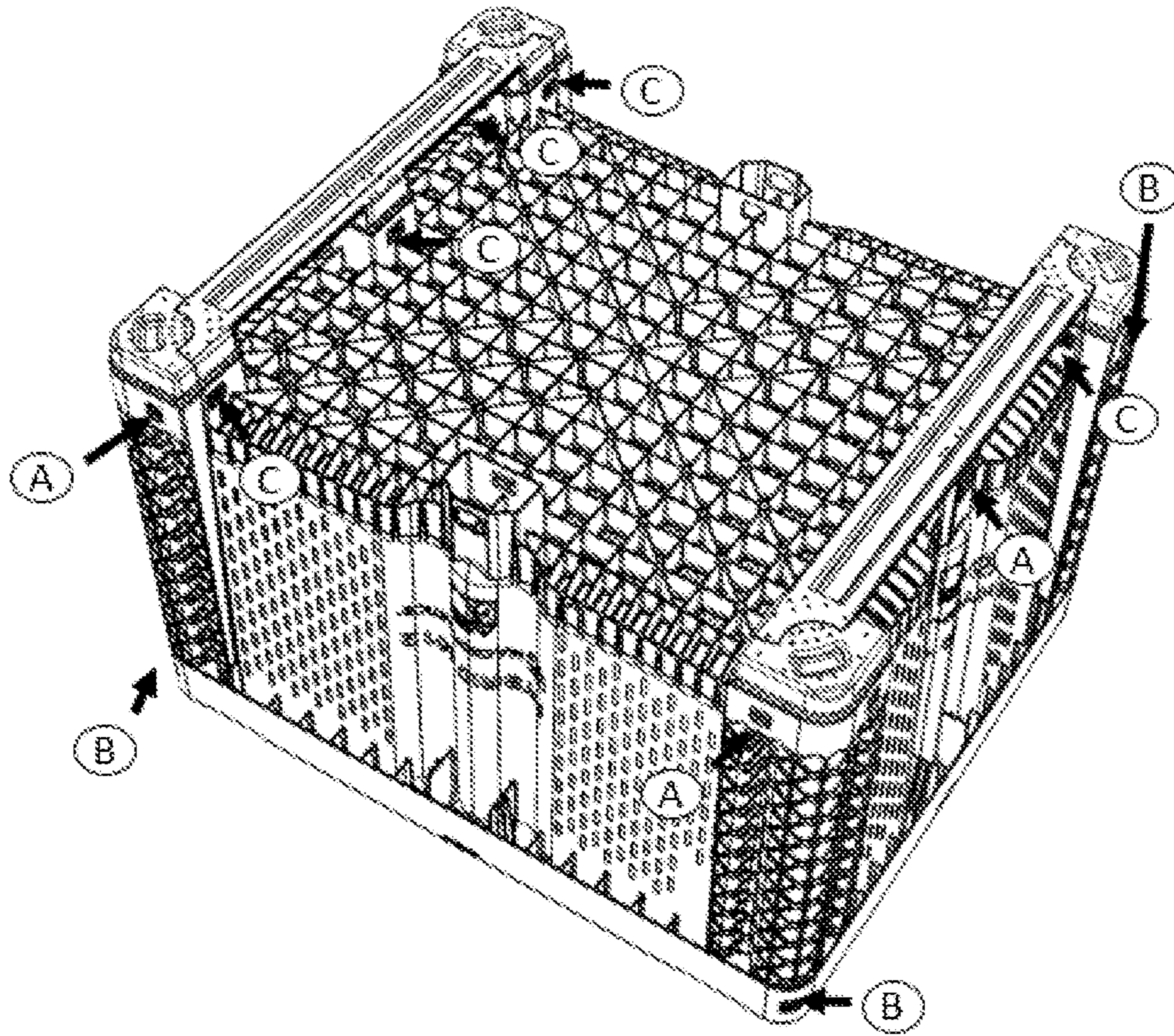

Figure 31

1**SHIPPING CONTAINERS WITH
INTERCHANGEABLE FEET****CROSS-REFERENCE TO RELATED
APPLICATIONS**

This patent application claims the benefit of and priority to U.S. Provisional Patent Application Ser. No. 63/024,067, with a filing date of May 13, 2020, the contents of which are fully incorporated herein by reference.

FIELD OF INVENTION

The embodiments described herein relate to shipping containers made of multiple components (including interchangeable feet) that can be easily assembled, disassembled, and replaced.

BACKGROUND

For many years, industries dealing in bulk goods have utilized returnable shipping containers. The use of the conventional shipping container, however, presents a number of disadvantages to the transportation, shipping, agricultural, retail, and handling industry. In particular, the conventional shipping container often comprises a single piece of plastic (as a non-limiting example) consisting of a basket and bottom components (referred to herein as “feet”) which are positioned underneath the basket to contact the floor or ground. During transportation and use, the feet are often damaged and need to be repaired. However, rather than replacing the one damaged component, the entire shipping container has to be replaced because it comprises a single piece. As such, the typical conventional shipping container is difficult to assemble, disassemble, and repair.

Accordingly, there is a significant need for a shipping container that can be rapidly assembled, disassembled, and easily repaired. Such a shipping container would provide industries dealing in bulk goods with the ability to easily replace a single damaged component without replacing the entire container. Along with other features and advantages outlined herein, the shipping containers within the scope of present embodiments meet these and other needs.

SUMMARY OF EMBODIMENTS

A shipping container with removable feet, referred to herein as a “shipping container” for brevity, according to multiple embodiments and alternatives, comprises a variety of components that can be easily interconnected and repaired. In some embodiments, the shipping container comprises a basket, a pair of feet, and corner columns, all of which are removable and interconnected by a variety of connections including but not limited to locking buttons, press release buttons, and pull clips (explained in more detail below). According to multiple embodiments and alternatives, the corner columns secure to the basket by a single release button and, at the same time, secure the pair of feet to the bottom surface of the basket. To remove the feet or the corner columns, a user can simply press the single release button on the corner columns. As such, the interconnectivity of the components permits rapid assembly, disassembly, and easy repair of the shipping container.

Likewise, the corner columns protect the containers by absorbing and recoiling impact rather than resisting the blow and breaking. In some embodiments, when the feet and removable columns are removed, the baskets nest into each

2

other for economical shipping and storage when empty. The feet and removable columns can also be locked into place or removed for returnable shipping and storage. Accordingly, the shipping containers described herein provide improved shipping efficiencies over conventional containers.

In some embodiments, the corner columns are not removable and the shipping container comprises a basket, a pair of feet, and a plurality of foot pads, all of which are easily interconnected to one another. According to multiple embodiments and alternatives, the pair of feet pads secure to the bottom corners of the basket by a single release button and, at the same time, secure the pair of feet to the bottom surface of the basket.

In conventional shipping containers, the components are often connected by tabs that have to be drilled out and then chipped away for assembly. This conventional approach is, however, time consuming and difficult. The current embodiments address this problem by providing for a drill release lock comprising a pilot hole such that a drill (as a non-limiting example) can split a back support rib. These embodiments are superior to conventional drill tabs by permitting the drill release lock to easily and efficiently hinge, thereby providing a more secure connection between the components.

It will be appreciated by one of ordinary skill in the art that any number of component interconnections may be selected as needed by a user. As non-limiting examples, a user may desire to utilize the shipping container for harvesting agricultural products in a long growing season. Accordingly, the user can select the more permanent connections consisting of locked buttons and press release buttons. If a user desires to disassemble the shipping container in the winter, the user may select interconnections comprising press release buttons and pull clips that can be more easily disassembled. Likewise, a user may wish to easily transport the container for returnable shipping and storage. As such, a user may select a shipping container with removable columns and feet interconnected by locked buttons, press release buttons, and pull clips.

Accordingly, the shipping containers in current embodiments can be rapidly assembled, disassembled, and repaired, thereby providing a key advantage over conventional shipping containers. Along with other features disclosed herein, the versatility and ease of operation of the shipping containers provide a number of advantages over conventional shipping containers.

BRIEF DESCRIPTION OF THE FIGURES

The drawings and embodiments described herein are illustrative of multiple alternative structures, aspects, and features of the present embodiments, and they are not to be understood as limiting the scope of present embodiments. It will be further understood that the drawing Figures described and provided herein are not to scale, and that the embodiments are not limited to the precise arrangements and instrumentalities shown.

FIG. 1 is a top, exploded, and perspective view of a shipping container comprising a basket, a pair of feet, and corner columns, according to multiple embodiments and alternatives.

FIG. 2 is a bottom, exploded, and perspective view of a shipping container comprising a basket, a pair of feet, and corner columns, according to multiple embodiments and alternatives.

3

FIG. 3 is a close up view of the bottom of a basket, a foot, and corner columns, according to multiple embodiments and alternatives.

FIG. 4 is a bottom, perspective view of a shipping container comprising a basket, a pair of feet, and corner columns, according to multiple embodiments and alternatives.

FIG. 5 is a bottom, perspective view of an assembled shipping container, according to multiple embodiments and alternatives.

FIG. 6 is a top, perspective view of an assembled shipping container, according to multiple embodiments and alternatives.

FIG. 7 is a bottom, exploded, and perspective view of a shipping container comprising a basket, a pair of feet, and feet pads, according to multiple embodiments and alternatives.

FIG. 8 is a top, exploded, and perspective view of a shipping container comprising a basket, a pair of feet, and feet pads, according to multiple embodiments and alternatives.

FIG. 9 is a close up view of the bottom of a basket, a foot, and feet pads, according to multiple embodiments and alternatives.

FIG. 10 is a close up view of a basket, a foot, and feet pads, according to multiple embodiments and alternatives.

FIG. 11 is a bottom, perspective view of an assembled shipping container, according to multiple embodiments and alternatives.

FIG. 12 is a top, perspective view of an assembled shipping container, according to multiple embodiments and alternatives.

FIG. 13 is a perspective view of a foot pad with a drill release lock, according to multiple embodiments and alternatives.

FIG. 14 is a perspective view of a foot pad with a drill release lock, according to multiple embodiments and alternatives.

FIG. 15 is a perspective view of a foot pad with a drill release lock following engagement with a drill, according to multiple embodiments and alternatives.

FIG. 16 is a perspective view of a foot pad with a drill release lock following engagement with a drill, according to multiple embodiments and alternatives.

FIG. 17 is a perspective view of a foot pad and a basket, according to multiple embodiments and alternatives.

FIG. 18 is a perspective view of a foot pad and a basket, according to multiple embodiments and alternatives.

FIG. 19 is a perspective view of a foot pad and a basket, according to multiple embodiments and alternatives.

FIG. 20 is a perspective view of a foot pad and a basket, according to multiple embodiments and alternatives.

FIG. 21 is a perspective view of a foot pad and a basket following engagement with a drill, according to multiple embodiments and alternatives.

FIG. 22 is a close up view of a foot pad and a basket following engagement with a drill, according to multiple embodiments and alternatives.

FIG. 23 is a close up view of a foot pad and a basket following engagement with a drill, according to multiple embodiments and alternatives.

FIG. 24 is a bottom, exploded view of a shipping container comprising a basket and a pair of feet, according to multiple embodiments and alternatives.

FIG. 25 is a bottom view of an assembled shipping container comprising a basket and a pair of feet, according to multiple embodiments and alternatives.

4

FIG. 26 is a bottom, exploded view of a shipping container comprising a basket and a pair of feet, according to multiple embodiments and alternatives.

FIG. 27 is a bottom view of an assembled shipping container comprising a basket and a pair of feet, according to multiple embodiments and alternatives.

FIG. 28 is a bottom, exploded view of a shipping container comprising a basket and a pair of feet, according to multiple embodiments and alternatives.

FIG. 29 is a bottom view of an assembled shipping container comprising a basket and a pair of feet, according to multiple embodiments and alternatives.

FIG. 30 is a bottom view of a shipping container comprising a basket, a pair of feet, and corner columns, according to multiple embodiments and alternatives.

FIG. 31 is a bottom view of an assembled shipping container comprising a basket, a pair of feet, and corner columns, according to multiple embodiments and alternatives.

MULTIPLE EMBODIMENTS AND ALTERNATIVES

FIGS. 1-3 show exploded views of shipping container 5, according to multiple embodiments and alternatives. Shipping container 5 consists of a basket 8, a plurality of corner columns 65, and feet 38 (also referred to herein as a plurality of feet). As shown in FIG. 1, basket 8 comprises top rim 10, support members 12 (which are positioned between the side walls 20 and the top rim 10), and corners 17 (also referred to as a plurality of corner faces which are defined by the pair of opposing sides of the basket 8). As shown most clearly in FIG. 2, the top rim 10 defines a plurality of slots 18 which are adapted to receive the top member 78 of the corner columns 65. The top rim 10 also defines a plurality of button receiving holes 15, located adjacent to the corners 17, which are adapted to receive the release button 80 of the corner columns 65.

As shown in FIGS. 2-3, the basket 8 includes a bottom surface 25 comprising a series of reinforcing cells 28 and a plurality of extensions 30 which extend downward. Each of the extensions 30 consist of sidewalls 31 which define foot receiving bores 35 (also referred to as apertures herein) that are adapted to receive the middle component 50 and end components 52, respectively, of the feet 38. The sidewalls 31 of the extensions 30 also define a bottom edge 32 and a plurality of pull clip openings 36 that are adapted to receive the pull clips 58 of the feet 38.

The corner columns 65 each consist of a top member 78, a middle member 82, a bottom member 90, a top surface 72, a bottom surface 75, an internal side 68, and an external side 70. The internal side 68 is adapted to mate with the corners 17 of the basket 8, and the top member 78 is adapted to mate with the plurality of slots 18 of basket 8. In some embodiments, the top member 78 is permanently connected to the middle member 82, and includes a release button 80 positioned on the external side 70. The release button 80 is hingeably connected to external side 70 of the top member 78 such that a user can push the release button 80 inward within the top member 78. The release button 80 is adapted to mate and connect with the button receiving hole 15 of basket 8.

The middle member 82 of the corner columns 65 includes grooves 85 which span its length and provide support. The middle member 82 also defines button receiving hole 88 which is adapted to receive the locked button 98 of the bottom member 90. The middle member 82 also defines an

5

opening at its bottom end (not shown in the figures) that receives the bottom member 90. In some embodiments, the bottom member 90 is received within the bottom of the middle member 82 and includes locked button 98. When locked button 98 is received within the button receiving hole 88, the bottom member 90 is fixably attached to the middle member 82. As shown in FIGS. 2 and 3, the bottom member 90 also includes lip 92 and a protrusion 95 which extends upward from lip 92. Lip 92 and protrusion 95 are adapted to connect and secure to the notch 48 of the feet 38.

The feet 38 each consist of a top surface 40, a bottom surface 42, a middle component 50, and end components 52. The bottom surface 42 includes a groove 45 which spans the bottom length of the feet 38 and provides support. The ends of the bottom surface 42 also comprise a notch 48 which is adapted to receive the lip 92 and protrusion 95 of the corner columns 65. The middle component 50 and end components 52 each include support ribs 62 (best shown in FIG. 1). According to multiple embodiments and alternatives, the middle component 50 and end components 52 each include a shoulder 55 which is larger than the plurality of foot receiving bores 35 and is adapted to engage the bottom edge 32 of the extensions 30. The middle component 50 and the end components 52 further include a plurality of tabs 60 which extend upward from, and are hingeably connected to, shoulder 55. The plurality of tabs 60 are adapted to flexibly engage the sidewalls 31 of extensions 30 upon entry of the components 50, 52 into the plurality of foot receiving bores 35. In some embodiments, the outer surface of the tabs 60 further includes pull clips 58 which are adapted to connect with the pull clip openings 36. Upon entry of the components 50, 52 into the plurality of foot receiving bores 35, the tabs 60 flex inward and engage the sidewalls 31, and the pull clips 58 engage and secure to the pull clip openings 36.

FIG. 4 illustrates a step in the assembly of shipping container 5, according to multiple embodiments and alternatives. In operation, to assemble shipping container 5, a user first places the basket 8 upside down such that the bottom surface 25 is facing upwards (as shown in FIG. 4). Next, a user securely attaches the feet 38 into the bottom surface 25 of the basket 8 by aligning the components 50, 52 with the plurality of foot receiving bores 35. The user then inserts the components 50, 52 into the plurality of foot receiving bores 35 until the shoulders 55 engage the bottom edge 32 of the extensions 30 and the pull clips 58 are secured within the pull clip openings 36. As shown in FIG. 4, the user then attaches the corner columns 65. In some embodiments, the corners 17 of basket 8 and the internal side 68 of the corner columns 65 contain corresponding markings to guide the user on where to attach the corner columns 65. For example, FIGS. 1 and 2 illustrate corresponding "A" and "B" markings. To attach the corner columns 65, the user inserts the top member 78 into the slot 18 of the basket 8 until the release button 80 is securely attached to the button receiving hole 15 and the protrusion 95 of the bottom member 90 engages the notch 48 of the feet 38.

FIGS. 5 and 6 illustrate assembled shipping container 5. According to multiple embodiments and alternatives, the release button 80 and the engagement between the protrusion 95 and the notch 48 securely attaches both the feet 38 and the corner columns 65 to the basket 8. To disassemble the shipping container 5, a user can simply press the release button 80 inwardly and pull the corner columns 65 from the slots 18. To remove the feet 38, the user simply pulls the feet 38 out of the plurality of feet receiving bores 35 (e.g. by pulling upward on the feet 38 shown in FIG. 5). When a pulling force is applied to the tabs 60 and pull clips 58, the

6

tabs 60 pivot inward and permit the user to remove the feet 38 from the bottom surface of the basket 8.

FIGS. 7-10 illustrate exploded views of shipping container 105 which consists of basket 108, a pair of feet 138, and a plurality of foot pads 165. Basket 108 consists of sidewalls 120, and corner columns 110 which are permanently attached to basket 108 (i.e. not removable). The corner columns 110 define an external face. The bottom of the corner columns 110 define a bottom edge 114, and a bottom opening 112. In some embodiments, internal support members 113 span the inside of the corner columns 110. As shown in FIGS. 7 and 9, the bottom opening 112 further comprises a foot receiving bore 115 and a foot pad receiving bore 118, which are adapted to receive the end components 152 of the feet 138 and the foot pads 165, respectively. The external face of corner columns 110 also define a button receiving hole 119, located proximal to the bottom opening 112, that is adapted to receive the release button 182 of the foot pads 165.

The bottom surface 125 of basket 108 comprises a series of reinforcing cells 128 and a plurality of extensions 130 that extend towards the ground. The plurality of extensions 130 comprise sidewalls 131 which define both a bottom edge 132 and foot receiving bores 135 that are adapted to receive the middle component 150 of the feet 138. In some embodiments, the sidewalls 131 also define button openings 136 that are adapted to receive pull clips 158 (located on the middle component 150 of the feet 138).

The feet 138 consist of a top surface 140, a bottom surface 142, a middle component 150, and end components 152. As shown in FIG. 9, a groove 145 spans the length of the bottom surface 142 and provides additional support for the feet 138. Both the middle component 150 and the end components 152 comprise a shoulder 155 and a plurality of tabs 160 that are hingeably connected to and extend upward from shoulder 155. As best illustrated in FIG. 10, in some embodiments the tabs 160 of the middle component 150 further comprise pull clips 158 and the tabs 160 of the end components 152 further include a plurality of barbs 163. When the feet 138 are inserted into the bottom opening 112 and the foot receiving bores 135, the tabs 160 hinge inward and then engage the basket 108 and the internal support members 113. Likewise, the pull clips 158 are secured to button openings 136. As shown in FIGS. 9-10, the end components 152 further define a notch 148 positioned above the bottom surface 142 that is adapted to receive the lip 185 and protrusion 188 of the foot pads 165. As shown in FIG. 10, the end components also include support ribs 162.

According to multiple embodiments and alternatives, the foot pads 165 comprise an internal side 168, an external side 170, a bottom surface 172 and wing members 180. A lip 185 with a protrusion 188 is positioned in between the wing members 180, and is adapted to engage and secure to the notch 148 of the feet 138. Likewise, the internal side 168 of the foot pads 165 is designed to mate with the end components 152 of the feet 138. Foot pads 165 further comprise tabs 178 which are hingeably connected to a shoulder 175. In some embodiments, the external side 170 of a tab 178 further includes a release button 182 that is adapted to be received in the button receiving hole 119 of the corner columns 110.

FIGS. 11 and 12 illustrate the assembled shipping container 105. According to multiple embodiments and alternatives, the release button 182 of the foot pads 165 and the engagement between the protrusion 188 and the notch 148 securely attach both the feet 138 and the foot pads 165 to the basket 108.

In operation, to assemble shipping container 105 a user first positions basket 108 such that bottom surface 125 is facing upwards (as shown in FIG. 11). A user then inserts the middle component 150 of feet 138 into extension 130 until shoulder 155 engages the bottom edge 132 and pull clip 158 is received within button opening 136. Likewise, a user inserts the end components 152 of the feet 138 into foot receiving bores 115 until shoulder 155 engages the bottom edge 114. Next, a user attaches the foot pads 165 by inserting the tabs 178 into foot pad receiving bore 118 until shoulder 175 engages the bottom edge 114 and release button 182 is received within button receiving hole 119. A user can quickly disassemble shipping container 105 by pressing inward on release button 182 and pulling foot pads 165 out of the basket 108 (e.g. pulling the foot pads 165 shown in FIG. 11 upwards). The user can then pull the feet 138 out of basket 108 by applying a force necessary to overcome the interaction between the pull clips 158 and button opening 136. For instance, in FIG. 11 the feet 138 could be pulled upward to remove the feet 138 from the basket 108.

FIGS. 13-16 illustrate foot pad 265 with a drill release lock 266. According to multiple embodiments and alternatives, the foot pad 265 consists of an internal side 268, an external side 270, wing members 278, a shoulder 272, a plurality of tabs 275 that are hingeably connected to the shoulder 272, and back support ribs 288 which are connected to the internal side 268 of the tabs 275. Foot pad 265 further comprises a lip 290 located in between wing members 278 and extending inwardly from the internal side 268. A protrusion 292 extends downward from the lip 290. As shown most clearly in FIGS. 13 and 17, protrusion 292 and lip 290 are adapted to be received in notch 248 of foot 238.

In some embodiments, drill release lock 266 is attached to the external side 270 of tabs 275. The drill release lock 266 includes a pilot hole 282 which aligns with the back support rib 288. As shown in FIG. 15, upon insertion of a drill (as a non-limiting example) into the pilot hole 282, the drill splits the back support rib 288 and creates a bore 285. Upon creation of the bore 285 in the back support rib 288, the tabs 275 with a drill release lock 266 can easily hinge (as shown in FIG. 16) thereby providing a more secure and efficient connection to basket 208.

FIGS. 17-23 illustrate foot pad 265, basket 208, and foot 238. As best illustrated in FIG. 17, the corner column 210 of basket 208 defines a foot pad receiving bore 218 which is adapted to receive foot pad 265. The corner column 210 also defines a plurality of button receiving holes 219 which are adapted to receive the drill release locks 266 of foot pad 265. In FIGS. 17-23, foot 238 is connected to basket 208 as described herein. Foot 238 defines notch 248 which is adapted to receive lip 290 and protrusion 292 of foot pad 265.

According to multiple embodiments and alternatives, a user may create bores 285 with a drill (as a non-limiting example) either before or after foot pad 265 is received in foot pad receiving bore 218. For instance, as shown in FIG. 17, the bores 285 have been created by a user prior to placement in the foot pad receiving bore 218. FIGS. 18-23 illustrate creation of bores 285 after foot pad 265 is received in both foot pad receiving bore 218 and notch 248 of foot 238. Likewise, the plurality of drill release locks 266 engage the button receiving holes 219 of the corner column 210. Once the foot 265 is connected to basket 208 and foot 238, a user can insert a drill (as a non-limiting example) into the pilot holes 282, as shown in FIGS. 19 and 20. After creation of bores 285, the tabs 275 with a drill release lock 266 hinge inwardly thereby providing a more secure and efficient

connection with the button receiving holes 219 of the corner column 210. FIGS. 22 and 23 illustrate close up views of a drill release lock 266 in which bore 285 has been created, thereby permitting tabs 275 to hinge inwardly and creating a more secure engagement between drill release lock 266 and button receiving hole 219.

According to multiple embodiments and alternatives, FIGS. 24-25 illustrate a shipping container 305 comprising a basket 308 and a pair of feet 338 (which span the entire bottom length of basket 308). It will be appreciated by one of ordinary skill in the art that any number of components described herein may be selected as needed by a user including but limited to feet 338, feet 138, feet 38, corner column 65, foot pads 165, foot pads 265, and combinations thereof.

It will also be appreciated by one of ordinary skill in the art that any number of component interconnections may be selected as needed by a user. FIGS. 26-29 illustrate a variety of component interactions for shipping container 305, and FIGS. 30-31 illustrate a variety of component interactions for shipping container 5. In FIGS. 26-31, the letter "A" refers to a locked button (e.g. locked button 98), the letter "B" refers to a release button (e.g. release button 80), and the letter "C" refers to a pull clip (e.g. pull clip 58), as non-limiting examples.

According to multiple embodiments and alternatives, a user may desire to utilize the shipping container for harvesting agricultural products in a long growing season (i.e. a "harvest" arrangement). As such, the user can select the more permanent connections consisting of locked buttons and release buttons as shown in FIGS. 26-27. If a user desires to disassemble the shipping container in the winter (referred to as a "knock down" arrangement), the user may select interconnections comprising press release buttons and pull clips that can be more easily disassembled, as shown in FIGS. 28-29. Likewise, a desire may wish to easily transport the container for returnable shipping and storage. As such, a user may select a shipping container 5 with removable corner columns 65 and feet 38 interconnected by locked buttons, press release buttons, and pull clips, as shown in FIGS. 30-31.

It will be understood that the embodiments described herein are not limited in their application to the details of the teachings and descriptions set forth, or as illustrated in the accompanying figures. Rather, it will be understood that the present embodiments and alternatives, as described and claimed herein, are capable of being practiced or carried out in various ways.

Also, it is to be understood that words and phrases used herein are for the purpose of description and should not be regarded as limiting. The use herein of "including," "comprising," "e.g.," "containing," or "having" and variations of those words is meant to encompass the items listed thereafter, and equivalents of those, as well as additional items.

Accordingly, the foregoing descriptions of several embodiments and alternatives are meant to illustrate, rather than to serve as limits on the scope of what has been disclosed herein. The descriptions herein are not intended to be exhaustive, nor are they meant to limit the understanding of the embodiments to the precise forms disclosed. It will be understood by those having ordinary skill in the art that modifications and variations of these embodiments are reasonably possible in light of the above teachings and descriptions.

What is claimed is:

1. A shipping container comprising:
a basket having a top rim, a bottom surface, and a pair of opposing, external sides defining a plurality of corner faces;
a plurality of feet, wherein each of the plurality of feet is adapted to be received in the bottom surface of the basket; and
a plurality of corner columns, wherein each of the plurality of corner columns comprise an internal side, an external side, a top member, and a bottom member;
wherein the top member of each of the plurality of corner columns is adapted to interlock with the top rim of the basket, the internal side of each of the plurality of corner columns is configured to be received in a corner face of the basket, and the bottom member of each of the plurality of corner columns is adapted to secure the plurality of feet to the bottom surface of the basket.
2. The shipping container of claim 1, wherein the bottom member of each of the plurality of corner columns further comprises a bottom surface, said bottom surface defining a lip which extends outwards from said internal side.
3. The shipping container of claim 2, wherein each of the plurality of feet further comprises a top surface, a bottom surface, a middle component and a pair of opposing end components, said middle component and said pair of end components each extending upwardly from said top surface of each of the plurality of feet, wherein a bottom surface of each of the pair of end components defines a notch being adapted to receive the lip of each of the plurality of corner columns.
4. The shipping container of claim 3, wherein the lip of each of the plurality of corner columns further defines a protrusion which extends upwards, said protrusion being adapted to interlock with each of the notches of the pair of end components of the plurality of feet.
5. The shipping container of claim 1, wherein the external side of the top member of each of the plurality of corner columns defines a release button, said release button being hingeably connected to the external side of said top member.
6. The shipping container of claim 5, wherein the top rim of the basket defines a plurality of button receiving holes, each of the plurality of button receiving holes being positioned proximal to the plurality of corner faces of said basket, and each of the plurality of button receiving holes being adapted to receive the release button of each of said plurality of corner columns.
7. The shipping container of claim 3, wherein the bottom surface of the basket defines a plurality of apertures, said plurality of apertures being adapted to receive the middle component and the pair of end components of each of the plurality of feet.

8. A shipping container comprising:
a basket having a bottom surface;
a plurality of feet, wherein each of the plurality of feet each is adapted to be received in the bottom surface of the basket; and
a plurality of foot pads, wherein the plurality of foot pads each comprise an internal side, an external side, a bottom surface, a pair of opposing wing members and a lip, said lip being positioned on the internal side of each of the plurality of foot pads and between the pair of opposing wing members.
9. The shipping container of claim 8, wherein the bottom surface of the basket defines a plurality of apertures, wherein the plurality of feet each are adapted to be received in the plurality of apertures of the basket.
10. The shipping container of claim 9, wherein the lip of each of the plurality of foot pads is adapted to secure each of the plurality of feet to the plurality of apertures of the basket.
11. The shipping container of claim 10, wherein each of the plurality of feet further comprises a top surface, a bottom surface, and a pair of opposing end components, said pair of end components each extending upwardly from said top surface of each of the plurality of feet.
12. The shipping container of claim 11, wherein a bottom surface of each of the pair of end components of said plurality of feet defines a notch being adapted to receive the lip of each of the plurality of foot pads.
13. The shipping container of claim 12, wherein the basket further comprises a plurality of corner columns integrally connected to said basket, wherein each of the plurality of corner columns defines a bottom opening, said bottom opening further defining a foot receiving bore and a foot pad receiving bore, wherein the foot receiving bore is adapted to receive an end component of each of the plurality of feet and the foot pad receiving bore is adapted to receive each of the plurality of foot pads.
14. The shipping container of claim 13, wherein each of the plurality of corner columns further comprises an external face, said external face defining a button receiving hole positioned proximal to the foot pad receiving bore.
15. The shipping container of claim 14, wherein each of the plurality of foot pads further comprises a shoulder, a first end tab, a second end tab, and a middle tab positioned between the first and second end tabs;
wherein the first end tab, the second end tab, and the middle tab each extend upwards from the shoulder and are hingeably connected to said shoulder.
16. The shipping container of claim 15, wherein an external side of the middle tab further defines a release button, said release button being adapted to be received in the button receiving hole of each of the plurality of corner columns.

* * * * *